

Handling- technology 3

Vacuum components

- + Suction cups
- + Adapters
- + Adapters + Compensation modules
- + Compensation modules
- + Vacuum generators
- + Sensing units
- + Handlings components
- + MCS modular construction system
- + Accessories

THE KNOW-HOW FACTORY

THE KNOW-HOW FACTORY

ZIMMER GROUP COMMITTED TO OUR CUSTOMERS

WE HAVE SUCCEEDED FOR YEARS BY OFFERING OUR CUSTOMERS INNOVATIVE AND INDIVIDUALIZED SOLUTIONS. ZIMMER HAS GROWN CONTINUOUSLY AND TODAY WE HAVE REACHED A NEW MILESTONE: THE ESTABLISHMENT OF THE KNOW-HOW FACTORY. IS THERE A SECRET TO OUR SUCCESS?

Foundation. Excellent products and services have always been the foundation of our company's growth. Zimmer is a source of ingenious solutions and important technical innovations. This is why customers with high expectations for technology frequently find their way to us. When things get tricky, Zimmer Group is in its best form.

Style. We have an interdisciplinary approach to everything we do, resulting in refined process solutions in six technology fields. This applies not just to development but to production. Zimmer Group serves all industries and stands ready to resolve even the most unique and highly individualized problems. Worldwide.

Motivation. Customer orientation is perhaps the most important factor of our success. We are a service provider in the complete sense of the word. With Zimmer Group, our customers have a single, centralized contact for all of their needs. We approach each customer's situation with a high level of competence and a broad range of possible solutions.

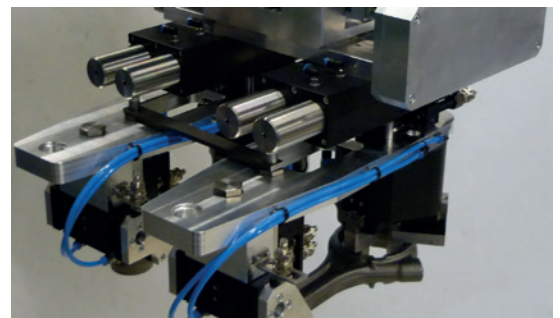

TECHNOLOGIES



HANDLING TECHNOLOGY

MORE THAN 30 YEARS OF EXPERIENCE AND INDUSTRY KNOWLEDGE: OUR PNEUMATIC, HYDRAULIC AND ELECTRICAL HANDLING COMPONENTS AND SYSTEMS ARE GLOBAL LEADERS.

Components. More than 2,000 standardized grippers, swivel units, robotic accessories and much more. We offer a complete selection of technologically superior products that are ready for rapid delivery.

Semi-standard. Our modular approach to design enables custom configurations and high rates of innovation for process automation.



DAMPING TECHNOLOGY

INDUSTRIAL DAMPING TECHNOLOGY AND SOFT CLOSE PRODUCTS EXEMPLIFY THE INNOVATION AND PIONEERING SPIRIT OF THE KNOW-HOW FACTORY.

Industrial damping technology.

Whether standard or customized solutions, our products stand for the highest cycle rates and maximum energy absorption with minimal space requirements.

Soft Close. Development and mass production of pneumatic and fluid dampers with extraordinary quality and rapid delivery.

OEM and direct. Whether they need components, returning mechanisms or complete production lines – we are the trusted partner of many prestigious customers.

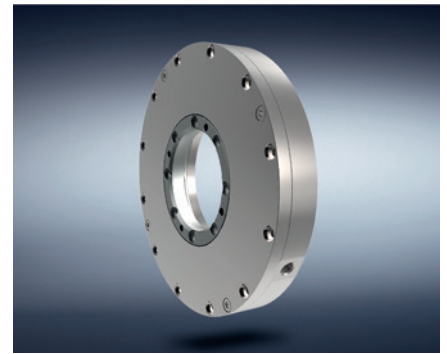

LINEAR TECHNOLOGY

WE DEVELOP LINEAR COMPONENTS AND SYSTEMS THAT ARE INDIVIDUALLY ADAPTED TO OUR CUSTOMERS' NEEDS.

Clamping and braking elements.

We offer you more than 4,000 types for profiled and round rails as well as for a variety of guide systems from all manufacturers. It makes no difference whether you prefer manual, pneumatic, electric or hydraulic drive.

Flexibility. Our clamping and braking elements ensure that movable components such as Z-axes or machining tables maintain a fixed position and that machines and systems come to a stop as quickly as possible in an emergency.

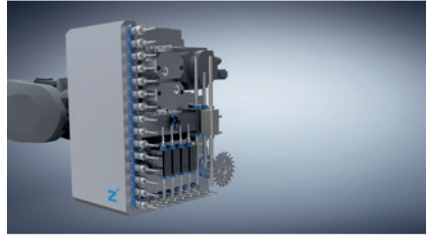
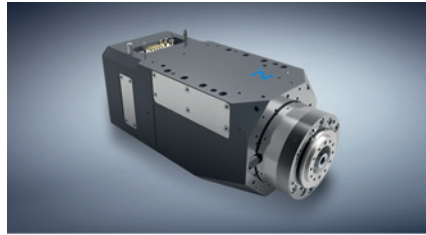

PROCESS TECHNOLOGY

MAXIMUM EFFICIENCY IS ESSENTIAL FOR SYSTEMS AND COMPONENTS USED IN PROCESS TECHNOLOGY. HIGH-LEVEL CUSTOM SOLUTIONS ARE OUR TRADEMARK.

A rich reservoir of experience. Our know-how ranges from the development of materials, processes and tools through product design to production of series products.

Deep production capabilities. The Zimmer Group pairs these capabilities with flexibility, quality and precision, even when making custom products.

Series production. We manufacture demanding products out of metal (MIM), elastomers and plastics with flexibility and speed.

MACHINE TECHNOLOGY

ZIMMER GROUP DEVELOPS INNOVATIVE METAL, WOOD AND COMPOSITE MATERIAL PROCESSING TOOL SYSTEMS FOR ALL INDUSTRIES. NUMEROUS CUSTOMERS CHOOSE US AS THEIR SYSTEMS AND INNOVATION PARTNER.

Knowledge and experience. Industry knowledge and a decades-long development partnership in exchangeable assemblies, tool interfaces and systems make us bound for new challenges around the world.

Components. We deliver numerous standard components from stock and develop innovative, customized systems for OEM and end customers – far beyond the metal and wood processing industries.

Variety. Whether you have machining centers, lathes or flexible production cells, the power tools, holders, assemblies and drilling heads of Zimmer Group are ready for action.

SYSTEM TECHNOLOGY

ZIMMER GROUP IS ONE OF THE LEADING SPECIALISTS IN THE DEVELOPMENT OF CUSTOMIZED SYSTEM SOLUTIONS WORLDWIDE.

Customized. A team made up of more than 20 experienced designers and project engineers develop and produce customized solutions for special tasks in close collaboration with end customers and system integrators. It doesn't matter if it is a simple gripper and handling solution or a complex system solution.

Solutions. These system solutions are used in many industries, from mechanical engineering to the automotive and supplier industries to plastics engineering and consumer goods industries, all the way to foundries. The Know-how Factory helps countless companies to thrive competitively by increasing automation efficiency.

COMPLETE PROGRAM IN OVERVIEW

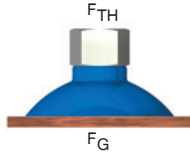

SUCTION CUPS RANGE

Page 8 - 11



SUCTION CUPS

1 Page 12 - 25



ADAPTERS

2 Page 26 - 29



ADAPTERS + COMPENSA- TION MODULES

3 Page 30 - 33



COMPENSATION MOD- ULES

4 Page 34 - 39



VACUUM GENERATORS

5 Page 40 - 51



SENSING UNITS

6 Page 52 - 57



HANDLING COMPONENTS

7 Page 58 - 111



MCS MODULAR CON- STRUCTION SYSTEM

8 Page 112 - 125



ACCESORIES

9 Page 126 - 133

1

2

3

4

5

6

7

8

9

SUCTION CUPS RANGE

SELECT THE RIGHT SUCTION CUPS

CALCULATIONS FOR THE EXAMPLE ARE CARRIED OUT BY FOLLOWING DATA:



■ Suction Plate round

Work piece

Material: Steel sheet stacked
 Surface: smooth, plane, dry
 Dimensions: Length max. 3000 mm
 Width max. 1000 mm
 Thickness max. 2.0 mm
 Weight approx. 47 kg

Handling system

Implemented system: Portal converter
 Present compressed-air: 8 bar
 Control voltage: 24 V DC
 Process flow: Implement horizontal-horizontal
 Maximum acceleration: X-, Y-Axis: 5 m/s²
 Z-Axis: 5 m/s²
 Cycle time: 30 s
 Required time: for suction: <1 s
 for depositing: <1 s



■ Torus Vacuum Cup

How much does your work piece weigh?

► For further calculations, it is significant to know which weight [m] your work piece has. You can calculate this by means of following formula:

L = Length [m]
 B = Width [m]
 H = Height [m]
 p = Density [kg/m³]

Mass m [kg]: $m = L \times B \times H \times p$

Example: $m = 3.0 \times 1.0 \times 0.0020 \times 7850$
 $m = 47.1 \text{ kg}$

How much load can the vacuum gripper carry?

► For calculating the holding force we need the weight. Additionally, the vacuum grippers have to apply acceleration forces which must not be neglected in a fully automatic system. To simplify the calculation three important and most frequent existing load cases are represented and described.

Significant

In the following simplified diagram about load cases I, II, III, the most unfavourable load case with the highest theoretical holding force has to be used or further calculations.



■ Bellows Cup oval

LOAD CASE I - VACUUM GRIPPER HORIZONTAL, FORCE VERTICAL

- FTH = theoretical holding force [N]
- m = mass [kg]
- g = Gravitational acceleration [9.81 m/s²]
- a = Acceleration [m/s²] of the plant (Emergency stop!)
- s = Security (minimum value 1.5-fold security, for critical, inhomogeneous or porous material or rough surface 2.0)

$$FTH = m \times (g + a) \times S$$

Example: $FTH = 47.1 \times (9.81 + 5) \times 1.5$
 $FTH = 1046 \text{ N}$

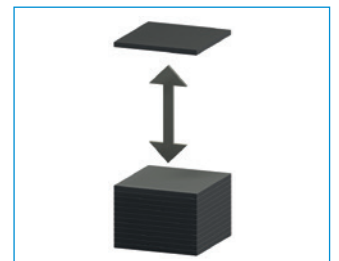
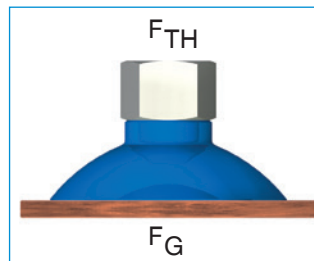

Vacuum grippers are horizontally on the top of the work piece which can be lifted.

SUCTION CUPS RANGE

SELECT THE RIGHT SUCTION CUPS



■ Suction Plate oval

LOAD CASE II- VACUUM GRIPPER HORIZONTAL, FORCE HORIZONTAL

- FTH = theoretical holding force [N]
- m = mass [kg]
- g = Gravitational acceleration [9.81 m/s²]
- a = Acceleration [m/s²] of the plant (Emergency stop!)
- μ = Friction coefficient = 0.1 for oily surfaces
 - = 0.2 ... 0.3 for wet surfaces
 - = 0.5 for wood, metal, glass, stone, ...
 - = 0.6 for rough surfaces

Attention! The indicated friction coefficients are averaged values and have to be checked for each work piece!

- s = Security (minimum value 1.5-fold security, for critical, inhomogeneous or porous material or rough surface 2.0)



■ Vacuum Cups

$$FTH = m \times (g + a / \mu) \times S$$

Example: $FTH = 47.1 \times (9.81 + 5 / 0.5) \times 1.5$
 $FTH = 1400 \text{ N}$

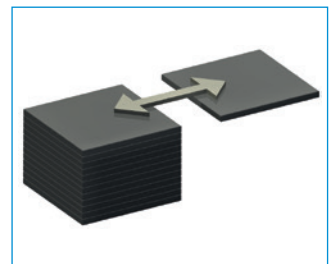
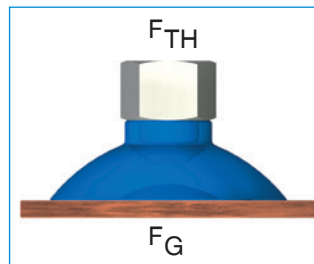

Vacuum grippers are fitted horizontally on a work piece which should be side-moved.

LOAD CASE III - VACUUM GRIPPER VERTICAL, FORCE VERTICAL

- FTH = theoretical holding force [N]
- m = mass [kg]
- g = Gravitational acceleration [9.81 m/s²]
- a = Acceleration [m/s²] of the plant (Emergency stop!)
- μ = Friction coefficient = 0.1 for oily surfaces
= 0.2 ... 0.3 for wet surfaces
= 0.5 for wood, metal, glass, stone, ...
= 0.6 for rough surfaces

Attention! The indicated friction coefficients are averaged values and have to be checked for each work piece!

- s = Security (minimum value 2.0-fold security, for critical, inhomogeneous or porous work pieces or rough surfaces 2.0 also higher)

According to the task of the sample calculation, the load case III shouldn't be considered. Metal sheets should only be used horizontally lying.

Comparison:

The results of load cases I and II are compared and a maximum value is yielded. Value for FTH = 1400 N from load case II.



■ Knobbed Vacuum Cups

$$F_{TH} = (m / \mu) \times (g + a) \times S$$

Example: $F_{TH} = (47.1 / 0.5) \times (9.8 + 5) \times 2$
 $F_{TH} = 2790 \text{ N}$

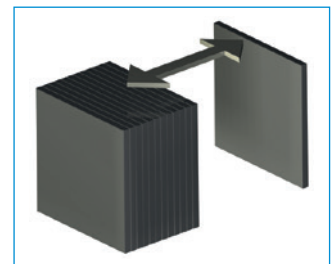
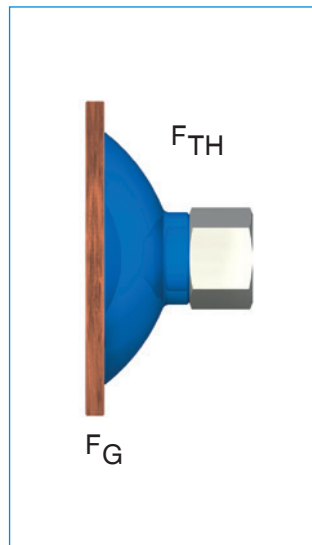

Vacuum grippers are fitted vertically or horizontally on a work piece which should be moved vertically respectively rotated













SUCTION CUPS

OVERVIEW OF SERIES

1



▶ SUCTION CUPS

	Material overview	14
	Fixing types	15
	Series SM - Vacuum Cups	16
	Series HS - Hand-held Vacuum	16
	Series SGF - Vacuum Cups	17
	Series NS - Knobbed Vacuum Cups	18
	Series SFK - Bellows Cup	19
	Series SF - Bellows Cup	20
	Series SFO - Bellows Cup oval	21
	Series OV - Suction cups oval	22
	Series SR/SK - Torus vacuum cup	23
	Series SPO - Suction plate oval	24
	Series SP - Suction plate	25

SUCTION CUPS

MATERIAL OVERVIEW

Due to the property table, various suction cups materials can be selected with regard to the customer-specific application. For simplification: features of the material are referred to frequent occurring requirements and are marked according to its suitability.

Abbreviation	▶ Suction cup material					
	NBR	NBR-AS	SI	SI tempered	SI-AS	TPU
Usual name	Nitrile rubber		Caoutchouc silicone			Polyurethan
Resistance to wear	2	2	3	3	3	1
Resistance to oil and grease	1	1	3	3	3	2
Resistance to weathering and ozone	3	3	1	1	1	2
Resistance to fuel	2	2	4	4	4	2
Resistance to Alcohol	1	3	1	2	3	1
Resistance to solvents	3	3	3	3	3	4
Suitability for food use	4	4	2	1	3	4
Low tendency to mark	4	4	1	1	1	2
Specific resistance [$\Omega \times \text{cm}$]	-	$\leq 10^7$	-	-	$\leq 10^7$	-
Operating temperature [$^{\circ}\text{C}$]	-20 - +110	-20 - +110	-55 - +180	-55 - +180	-20 - +150	-30 - +/-90
Shore hardness [A]	65 +/- 3	65 +/- 3	60 +/- 5	60 +/- 5	55 +/- 5	82 +/- 5
Colour / Identifier	black	black	blue	white	black	red

Abbreviation	▶ Material for round cord SP / SPO	
	EPDM	
Usual name	Foam rubber	
Resistance to wear	2	
Resistance to oil and grease	1	
Resistance to weathering and ozone	3	
Resistance to fuel	2	
Resistance to Alcohol	1	
Resistance to solvents	3	
Suitability for food use	4	
Low tendency to mark	4	
Specific resistance [$\Omega \times \text{cm}$]	-	
Operating temperature [$^{\circ}\text{C}$]	-30 - +80	
Shore hardness [A]	15 +/- 5	
Colour / Identifier	black	

1 - very good
2 - good
3 - satisfactory
4 - adequate

SUCTION CUPS

FIXING TYPES

Suction Cups, Adapters and Compensation Modules with the same connection type can be variably combined. Dimensions of each connection type can be taken from drawings given below.

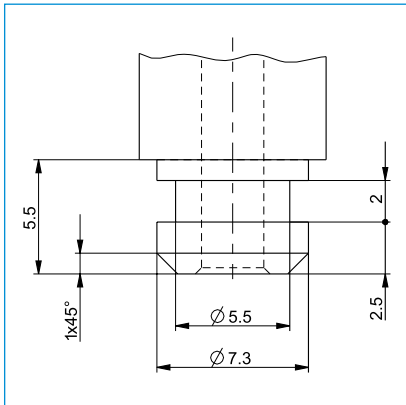

■ Fixing Types 1

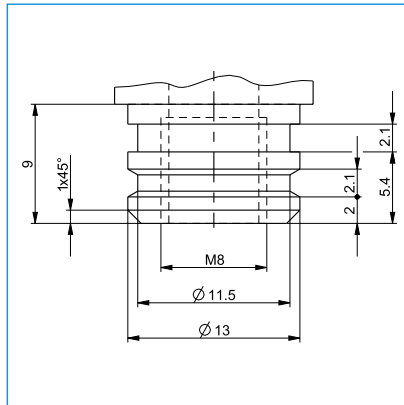

■ Fixing Types 2

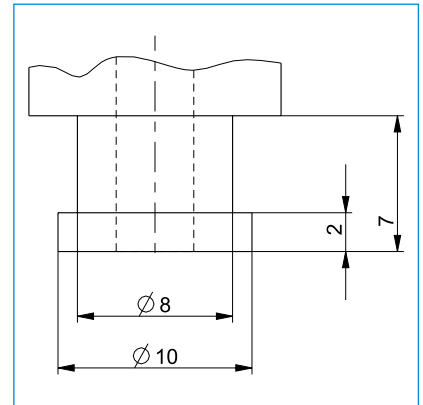

■ Fixing Types 3

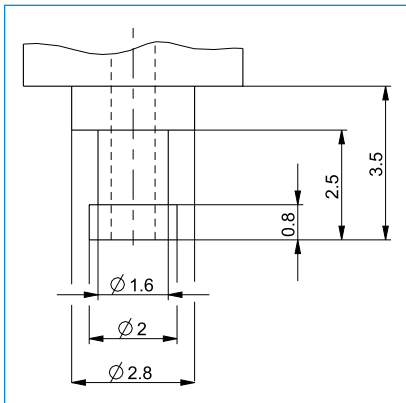

■ Fixing Types 4

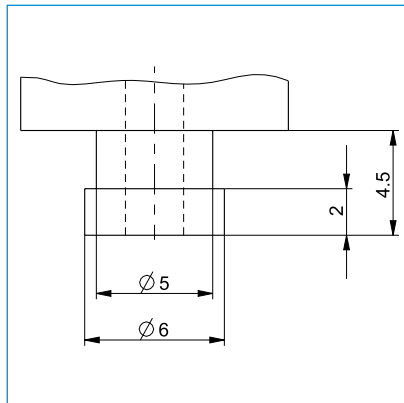

■ Fixing Types 5

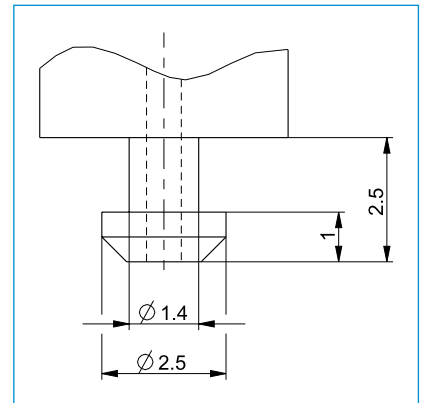

■ Fixing Types 6

SUCTION CUPS

SERIES SM / HS / SGF

1

Series SM / HS / SGF / Suction cups

► SERIES SM - VACUUM CUPS



► Range of applications

Flat and slightly curved surfaces

► Special features

Suction diameter from 1 mm

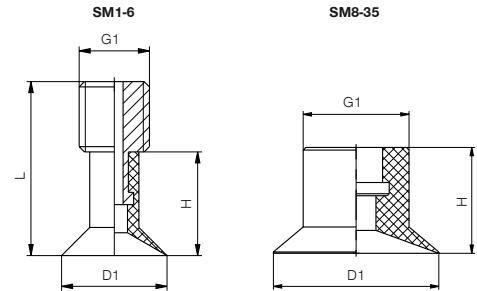

► Technical Data

Versions	Material	Color	Heat Resistant	Shore hardness	Add to part no.
Standard	Nitrile rubber	black	-20° C - +110° C	65 +/- 3	-
Antistatic	Nitrile rubber	black	-20° C - +110° C	65 +/- 3	NA (e.g. SM1NA)
Heat-resistant	Caoutchouc silicone	blue	-55° C bis +180° C	60 +/- 5	SI (e.g. SM1SI)
Food-handling	Caoutchouc silicone	white	-55° C bis +180° C	60 +/- 5	L (e.g. SM1L)
Antistatic	Caoutchouc silicone	black	-20° C bis +150° C	55 +/- 5	SA (e.g. SM1SA)
Low-wear	Polyurethan	red	-20° C bis +150° C	82 +/- 5	on request

► Technical Data

Order no.	SM1	SM2	SM3	SM4	SM5	SM6	SM8	SM10
Vacuum force theoretical [N]*	<0.1	0.3	0.6	1	1.6	2.3	4	6
Volume [cm³]	0.01	0.01	0.01	0.01	0.02	0.03	0.1	0.2
Fixing types	4/6	4/6	4/6	4/6	4/6	4/6	5	5
G1	M4	M4	M4	M4	M4	M4		
Dimension D1 [mm]	1	2	3	4	5	6	8	10
Dimension D2 [mm]							10	10
Dimension H [mm]	6	6	6	6	6	6	10	10
Dimension L [mm]		10	10	10	10	10		

► Technical Data

Order no.	SM12	SM15	SM18	SM20	SM25	SM30	SM35
Vacuum force theoretical [N]*	9	14	20	25	39	57	77
Volume [cm³]	0.2	0.4	0.5	0.6	1.3	1.8	2.6
Fixing types	5	1	1	1	3	3	3
G1							
Dimension D1 [mm]	12	15	18	20	25	30	35
Dimension D2 [mm]	10	12	12	12	16	16	16
Dimension H [mm]	10	12.5	12.5	12.5	16	16	16
Dimension L [mm]							

*at 0.8 bar Vacuum

► SERIES HS - HAND-HELD VACUUM

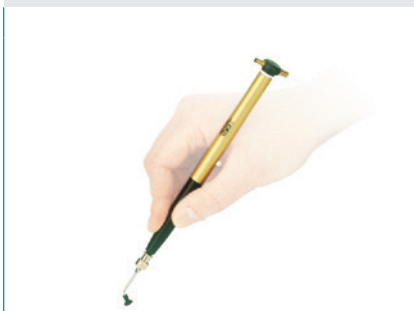

► Special features

Integrated ventur nozzle as vacuum generator, vacuum can be applied or removed by hand

Possible to combine with suction cups SM1 bis SM6

► Technical Data

Order no.	HS10
Air consumption per min. [l norm]	13

► **SERIES SGF - VACUUM CUPS**



► **Range of applications**

Flat and slightly curved surfaces

► **Special features**

Suction diameter from 6 mm

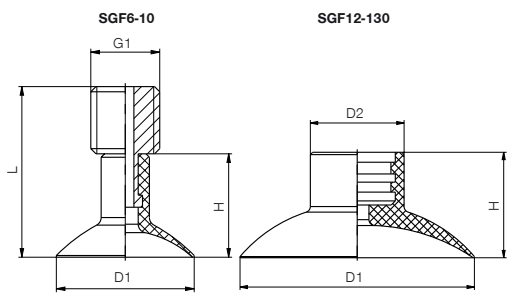

► **Technical Data**

Versions	Material	Color	Heat Resistant	Shore hardness	Add to part no.
Standard	Nitrile rubber	black	-20° C - +110° C	65 +/- 3	-
Antistatic	Nitrile rubber	black	-20° C - +110° C	65 +/- 3	NA (e.g. SGF6NA)
Heat-resistant	Caoutchouc silicone	blue	-55° C bis +180° C	60 +/- 5	SI (e.g. SGF6SI)
Food-handling	Caoutchouc silicone	white	-55° C bis +180° C	60 +/- 5	L (e.g. SGF6L)
Antistatic	Caoutchouc silicone	black	-20° C bis +150° C	55 +/- 5	SA (e.g. SGF6SA)
Low-wear	Polyurethan	red	-20° C bis +150° C	82 +/- 5	on request

► **Technical Data**

Order no.	SGF6	SGF8	SGF10	SGF12	SGF15	SGF18	SGF22
Vacuum force theoretical [N]*	2	4	6	9	13	19	29
Volume [cm³]	0.02	0.05	0.07	0.3	0.4	0.6	1.0
Fixing types	4/6	4/6	4/6	1	1	1	1
G1	M4	M4	M4				
Dimension D1 [mm]	6	8	10	12	15	18	22
Dimension D2 [mm]				10	10	10	10
Dimension H [mm]	6	6	6	11	11	12	12
Dimension L [mm]	10	10	10				

► **Technical Data**

Order no.	SGF25	SGF30	SGF35	SGF40	SGF60	SGF85	SGF130
Vacuum force theoretical [N]*	38	55	75	99	217	441	1042
Volume [cm³]	2	2.5	3.2	4.8	9.5	30	89
Fixing types	2	2	2	2	2	2	2
G1							
Dimension D1 [mm]	25	30	35	40	60	85	130
Dimension D2 [mm]	16	16	16	16	16	24.5	24.5
Dimension H [mm]	15	15	15	18	23	28	35
Dimension L [mm]							

*at 0.8 bar Vacuum

SUCTION CUPS

SERIES NS / SFK

1

Series NS / SFK / Suction cups

► SERIES NS - KNOBBED VACUUM CUPS



► Range of applications

Flat and unstable surfaces

► Special features

Knobs prevent thin material being sucked in

High stability

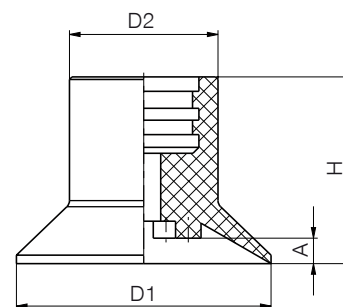

► Technical Data

Versions	Material	Color	Heat Resistant	Shore hardness	Add to part no.
Standard	Nitrile rubber	black	-20° C - +110° C	65 +/- 3	-
Antistatic	Nitrile rubber	black	-20° C - +110° C	65 +/- 3	NA (e.g. NS10NA)
Heat-resistant	Caoutchouc silicone	blue	-55° C bis +180° C	60 +/- 5	SI (e.g. NS10SI)
Food-handling	Caoutchouc silicone	white	-55° C bis +180° C	60 +/- 5	L (e.g. NS10L)
Antistatic	Caoutchouc silicone	black	-20° C bis +150° C	55 +/- 5	SA (e.g. NS10SA)
Low-wear	Polyurethan	red	-20° C bis +150° C	82 +/- 5	on request

► Technical Data

Order no.	NS10	NS15	NS18	NS24	NS30	NS40
Vacuum force theoretical [N]*	6	14	20	36	57	101
Volume [cm³]	0.3	0.4	0.5	2.2	3	5.2
Fixing types	1	1	1	2	2	2
Dimension A [mm]	1	1.5	0.8	3.5	3	3.5
Dimension D1 [mm]	10	15	18	24	30	40
Dimension D2 [mm]	10	10	10	16	17.5	18
Dimension H [mm]	12	12	12	22	22	22

► Technical Data

Order no.	NS50	NS60	NS70	NS85	NS100
Vacuum force theoretical [N]*	157	226	3.8	454	628
Volume [cm³]	8.4	12	20.5	30	41
Fixing types	2	2	2	2	2
Dimension A [mm]	3.5	3.5	3.5	3.5	3.5
Dimension D1 [mm]	50	60	70	85	100
Dimension D2 [mm]	19	19	19	19	19
Dimension H [mm]	22	22	22	22	22

*at 0.8 bar Vacuum

► **SERIES SFK - BELLOWS CUP**



► **Range of applications**

Slightly curved, inclined and uneven surfaces

► **Special features**

Compensates differences in height

The suction process creates a lifting effect

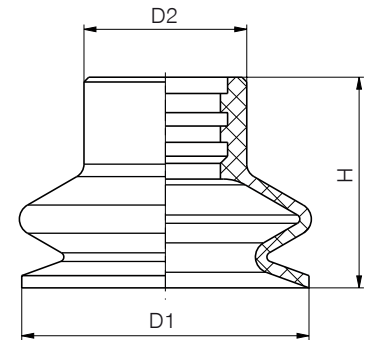

Versions	Material	Color	Heat Resistant	Shore hardness	Add to part no.
Standard	Nitrile rubber	black	-20° C - +110° C	65 +/- 3	-
Antistatic	Nitrile rubber	black	-20° C - +110° C	65 +/- 3	NA (e.g. SFK24NA)
Heat-resistant	Caoutchouc silicone	blue	-55° C bis +180° C	60 +/- 5	SI (e.g. SFK24SI)
Food-handling	Caoutchouc silicone	white	-55° C bis +180° C	60 +/- 5	L (e.g. SFK24L)
Antistatic	Caoutchouc silicone	black	-20° C bis +150° C	55 +/- 5	SA (e.g. SFK24SA)
Low-wear	Polyurethan	red	-20° C bis +150° C	82 +/- 5	on request

Order no.	► Technical Data		
	SFK24	SFK30	SFK40
Vacuum force theoretical [N]*	36	57	101
Lifting force [N]	11	14.5	28
Volume [cm³]	3.8	5.8	10.4
Fixing types	2	2	2
Dimension D1 [mm]	24	30	40
Dimension D2 [mm]	17	17	17
Dimension H min. [mm]	13	15	20
Dimension H max. [mm]	19	22	27

*at 0.8 bar Vacuum

SUCTION CUPS

SERIES SF / SFO

1

► SERIES SF - BELLOWS CUP



► Range of applications

Slightly curved, inclined and uneven surfaces

► Special features

Compensates differences in height

The suction process creates a lifting effect

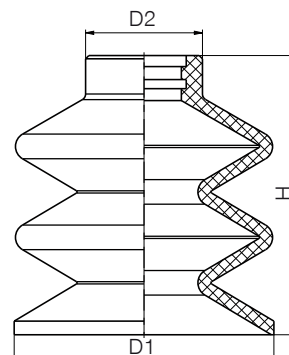

► Technical Data

Versions	Material	Color	Heat Resistant	Shore hardness	Add to part no.
Standard	Nitrile rubber	black	-20° C - +110° C	65 +/- 3	-
Antistatic	Nitrile rubber	black	-20° C - +110° C	65 +/- 3	NA (e.g. SF10NA)
Heat-resistant	Caoutchouc silicone	blue	-55° C bis +180° C	60 +/- 5	SI (e.g. SF10SI)
Food-handling	Caoutchouc silicone	white	-55° C bis +180° C	60 +/- 5	L (e.g. SF10L)
Antistatic	Caoutchouc silicone	black	-20° C bis +150° C	55 +/- 5	SA (e.g. SF10SA)
Low-wear	Polyurethan	red	-20° C bis +150° C	82 +/- 5	on request

► Technical Data

Order no.	SF10	SF15	SF18	SF24	SF30	SF40
Vacuum force theoretical [N]*	6	12	20	35	55	97
Lifting force [N]	2.2	4	6	9.5	13	25
Volume [cm ³]	0.5	1.1	1.8	4.5	8.9	19.5
Fixing types	1	1	1	2	2	2
Dimension D1 [mm]	10	15	18	24	30	40
Dimension D2 [mm]	10	10.2	12	16.5	17	18
Dimension H min. [mm]	10	10	11	18	22	27
Dimension H max. [mm]	14	15.5	18.7	26	35	43

► Technical Data

Order no.	SF50	SF60	SF85
Vacuum force theoretical [N]*	157	225	443
Lifting force [N]	42	54	90
Volume [cm ³]	32	62	166
Fixing types	2	2	2
Dimension D1 [mm]	50	60	85
Dimension D2 [mm]	20	20	24.5
Dimension H min. [mm]	30	35	50
Dimension H max. [mm]	48	58	76

*at 0.8 bar Vacuum

► SERIES SFO - BELLOWS CUP OVAL



► Range of applications

Long, narrow and slightly uneven surfaces

► Special features

Compensates differences in height

The suction process creates a lifting effect

Ear clamp to prevent rotation, supplied with product

Internal stainless steel spring to stabilize and maintain shape of suction cup

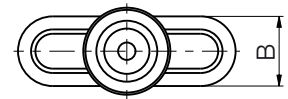
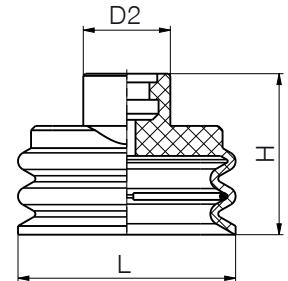

► Technical Data

Versions	Material	Color	Heat Resistant	Shore hardness	Add to part no.
Standard	Nitrile rubber	black	-20° C - +110° C	65 +/- 3	-
Antistatic	Nitrile rubber	black	-20° C - +110° C	65 +/- 3	NA (e.g. SFO8-25NA)
Heat-resistant	Caoutchouc silicone	blue	-55° C bis +180° C	60 +/- 5	SI (e.g. SFO8-25SI)
Food-handling	Caoutchouc silicone	white	-55° C bis +180° C	60 +/- 5	L (e.g. SFO8-25L)
Antistatic	Caoutchouc silicone	black	-20° C bis +150° C	55 +/- 5	SA (e.g. SFO8-25SA)
Low-wear	Polyurethan	red	-20° C bis +150° C	82 +/- 5	on request

► Technical Data

Order no.	SFO8-25	SFO15-45	SFO25-75
Vacuum force theoretical [N]*	15	49	139
Lifting force [N]	3.5	10	35
Volume [cm³]	0.9	6.1	20.4
Fixing types	1	2	2
Dimension B [mm]	8	15	25
Dimension D2 [mm]	10	17.5	17.5
Dimension H min. [mm]	14.5	19	22
Dimension H max. [mm]	18.5	28.5	34.5
Dimension L min. [mm]	25	45	75

*at 0.8 bar Vacuum

SUCTION CUPS

SERIES OV / SR/SK

1

► SERIES OV - SUCTION CUPS OVAL



► Range of applications

Long, narrow and slightly uneven surfaces

► Special features

Depending on type, metallic base plate

Flexible seal lips

Ear clamp to prevent rotation, supplied with product

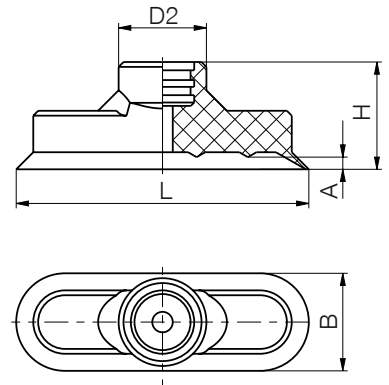

► Technical Data

Versions	Material	Color	Heat Resistant	Shore hardness	Add to part no.
Standard	Nitrile rubber	black	-20° C - +110° C	65 +/- 3	-
Antistatic	Nitrile rubber	black	-20° C - +110° C	65 +/- 3	NA (e.g. OV3x10NA)
Heat-resistant	Caoutchouc silicone	blue	-55° C bis +180° C	60 +/- 5	SI (e.g. OV3x10SI)
Food-handling	Caoutchouc silicone	white	-55° C bis +180° C	60 +/- 5	L (e.g. OV3x10L)
Antistatic	Caoutchouc silicone	black	-20° C bis +150° C	55 +/- 5	SA (e.g. OV3x10SA)
Low-wear	Polyurethan	red	-20° C bis +150° C	82 +/- 5	on request

► Technical Data

Order no.	OV3-10	OV5-15	OV6-18	OV8-24	OV10-30	OV12-36
Vacuum force theoretical [N]*	2	5	6	12	16	29
Volume [cm³]	0.2	0.2	0.3	0.4	0.6	0.8
Fixing types	1	1	1	1	1	1
Dimension A [mm]	0.4	0.6	1	1.6	1.2	1
Dimension B [mm]	3	5	6	8	10	12
Dimension D2 [mm]	9.5	8.5	8.5	12.3	12	12.5
Dimension H [mm]	12	12	12	12	12	12
Dimension L [mm]	10	15	18	24	30	36

► Technical Data

Order no.	OV15-45	OV20-60	OV25-75	OV28-85	OV35-100
Vacuum force theoretical [N]*	45	82	125	161	240
Volume [cm³]	2.3	3.4	5.6	8.1	11.8
Fixing types	2	2	2	2	2
Dimension A [mm]	2	2.5	3	3	3
Dimension B [mm]	15	20	25	28	35
Dimension D2 [mm]	16.5	18	18	18	19
Dimension H [mm]	22	22	22	22	22
Dimension L [mm]	45	60	75	85	100

*at 0.8 bar Vacuum

► SERIES SR/SK - TORUS VACUUM CUP



► Range of applications

Even, slightly curved and open surfaces

► Special features

Inner core allows suction to act on perforated surfaces

Recommended perforation diameter max. 70% of inner core

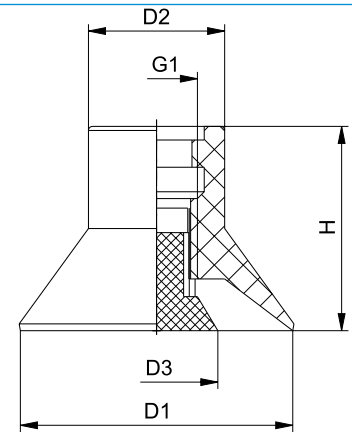

► Technical Data

Versions	Material	Color	Heat Resistant	Shore hardness	Add to part no.
Standard	Nitrile rubber	black	-20° C - +110° C	65 +/- 3	-
Antistatic	Nitrile rubber	black	-20° C - +110° C	65 +/- 3	NA (e.g. SR12NA+SK6NA)
Heat-resistant	Caoutchouc silicone	blue	-55° C bis +180° C	60 +/- 5	SI (e.g. SR12SI+SK6SI)
Food-handling	Caoutchouc silicone	white	-55° C bis +180° C	60 +/- 5	L (e.g. SR12L+SK6L)
Antistatic	Caoutchouc silicone	black	-20° C bis +150° C	55 +/- 5	SA (e.g. SR12SA+SK6SA)
Low-wear	Polyurethan	red	-20° C bis +150° C	82 +/- 5	on request

► Technical Data

Order no.	SR12+SK6	SR12+SK9	SR15+SK6	SR15+SK9	SR20+SK6	SR20+SK9	SR20+SK13
Vacuum force theoretical [N]*	7	4	12	9	23	20	15
Volume [cm³]	3	2.6	4.6	4.2	7.7	7.2	5.9
Fixing types	1	1	1	1	1	1	1
G1	M6	M6	M6	M6	M6	M6	M6
Dimension D1 [mm]	12	12	15	15	20	20	20
Dimension D2 [mm]	10	10	10	10	10	10	10
Dimension D3 [mm]	6	9	6	9	6	9	13
Dimension H [mm]	15	15	15	15	15	15	15

► Technical Data

Order no.	SR25+SK11	SR25+SK19	SR30+SK11	SR30+SK19	SR35+SK11	SR35+SK19	SR35+SK25
Vacuum force theoretical [N]*	30	15	49	34	69	54	37
Volume [cm³]	19.6	16.4	24.0	20.8	34	31	25
Fixing types	2	2	2	2	2	2	2
G1	M8	M8	M8	M8	M8	M8	M8
Dimension D1 [mm]	25	25	30	30	35	35	35
Dimension D2 [mm]	18	18	19	19	19	19	19
Dimension D3 [mm]	11	19	11	19	11	19	25
Dimension H [mm]	22	22	22	22	22	22	22

► Technical Data

Order no.	SR40+SK11	SR40+SK19	SR40+SK25	SR50+SK11	SR50+SK19	SR50+SK25
Vacuum force theoretical [N]*	93	76	61	143	128	112
Volume [cm³]	45	41	36	71	68	63
Fixing types	2	2	2	2	2	2
G1	M8	M8	M8	M8	M8	M8
Dimension D1 [mm]	25	25	30	30	35	35
Dimension D2 [mm]	18	18	19	19	19	19
Dimension D3 [mm]	11	19	25	19	19	25
Dimension H [mm]	22	22	22	22	22	22

*at 0.8 bar Vacuum

SUCTION CUPS

SERIES SPO / SP

1

Series SPO / SP / Suction cups

► SERIES SPO - SUCTION PLATE OVAL



► Range of applications

Rough, highly textured surfaces, such as corrugated metal and wood, etc...

► Special features

Highly adjustable sealing face

Robust and strong with aluminium carrier plate

NBR knobbed surface to absorb lateral forces

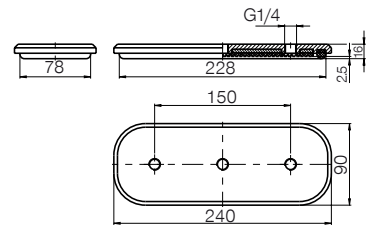

► Technical Data

Versions	Material	Color	Heat Resistant	Shore hardness	Add to part no.
Foam rubber	EPDM	black	-30° C bis +80° C	15 +/- 5	EPDM (e.g. SPO230-80-10EPDM)

► Technical Data

Order no.	SPO230-80-10EPDM
Vacuum force theoretical [N]	1318
Volume [cm ³]	221

► SERIES SP - SUCTION PLATE

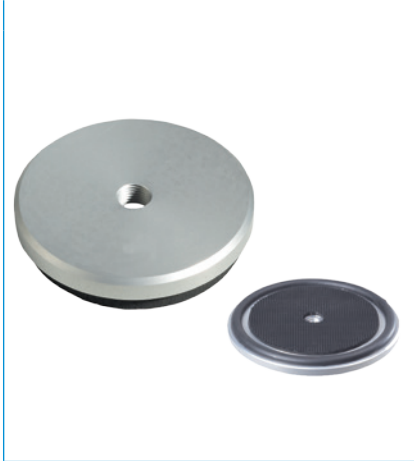

► Range of applications

Rough, highly textured surfaces, such as corrugated metal and wood, etc...

► Special features

Highly adjustable sealing face

Robust and strong with aluminium carrier plate

NBR knobby surface to absorb lateral forces

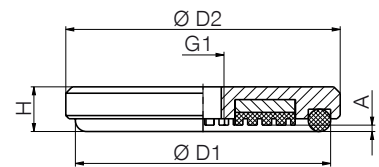

► Technical Data

Versions	Material	Color	Heat Resistant	Shore hardness	Add to part no.
Foam rubber	EPDM	black	-30° C bis +80° C	15 +/- 5	EPDM (e.g. SP80-7EPDM)

► Technical Data

Order no.	SP80-7EPDM	SP120-10EPDM	SP160-10EPDM
Vacuum force theoretical [N]	274	628	1232
Volume [cm³]	55	131	277
G1	G1/4"	G1/4"	G1/4"
Dimension A [mm]	2.5	2.5	2.5
Dimension D1 [mm]	80	120	160
Dimension D2 [mm]	86	128	168
Dimension H [mm]	14	15	16

ADAPTERS

OVERVIEW OF SERIES

2

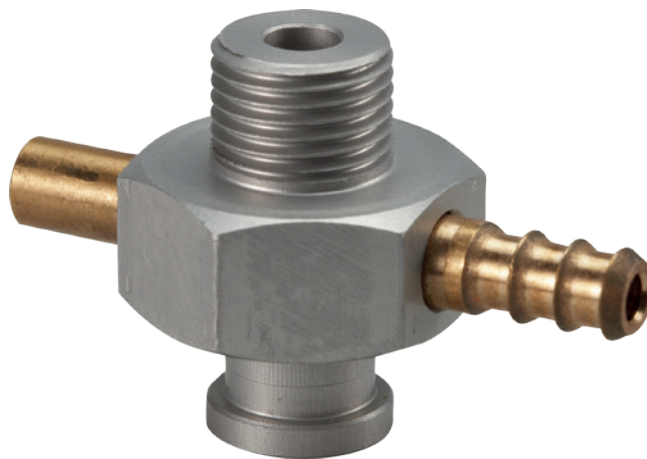

▶ ADAPTERS



Series SI - Adapter

28



Series SAM/SA - Adapter

28



Series SAVM/SAV/VGS-M - Adapter

29

ADAPTERS

SERIES S

► SERIES SI - ADAPTER



- **Special features**
- Internal thread
 - Vacuum connection

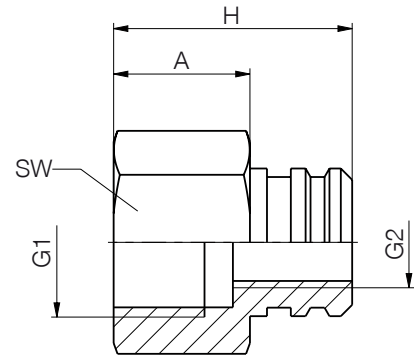

► Technical Data

Order no.	SI1-8	SI1-4
Fixing types	1	2
G1	G1/8"	G1/4"
G2		M8
Dimension A [mm]	10	12
Dimension H [mm]	15.5	21
SW [mm]	14	17

► SERIES SAM/SA - ADAPTER

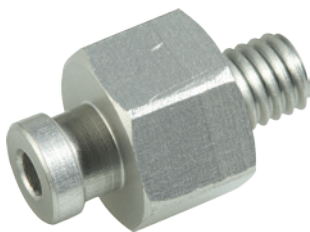

- **Special features**
- External thread
 - Vacuum connection

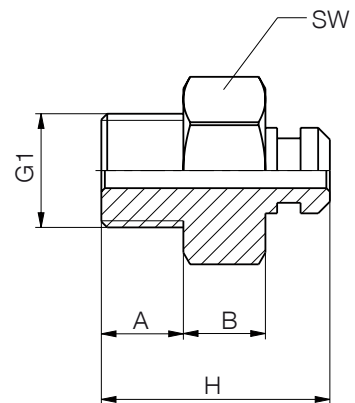

► Technical Data

Order no.	SAM5	SAM5-01	SA1-8	SA1-8-06	SA1-4
Fixing types	4	5	1	3	2
G1	7	7	7	8	8
G2	M5	M5	G1/8"	G1/8"	G1/4"
Dimension A [mm]	5	5	7	7	8
Dimension H [mm]	15.5	16.5	19.5	22	25
SW [mm]	10	10	14	17	17

► SERIES SAVM/SAV/VGS-M - ADAPTER

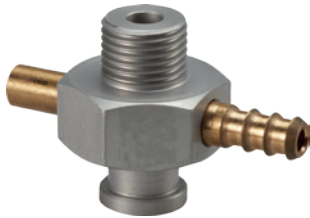

► Special features

- External thread
- Integrated vacuum generator
- Compressed air connection

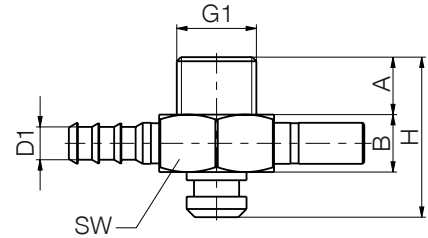

► Technical Data

Order no.	SAVM5	SAVM5-01	SAV1-8	SAV1-8-03	SAV1-4	VGS-M
Fixing types	4	5	1	3	2	6
Vacuum [bar]	-0.8	-0.8	-0.8	-0.8	-0.8	-0.8
Vacuum level [%]	81	81	78	78	82	83
Max. suction capacity [l/min]	4	4	3.5	3.5	11.5	1
Air consumption suction [l/min]	13	12	14.5	14.5	27	11
Operating pressure [bar]	6	6	6	6	6	6
Weight [g]	10	15.5	16.8	16.8	30.4	18.8
G1	M5	M5	G1/8"	G1/8"	G1/4"	M8
Dimension A [mm]	5	5	7	7	8	8
Dimension B [mm]	7	7	7	8	8	17.5
Dimension D1 [mm]	3	3	4	4	4	4
Dimension H [mm]	15.5	16.5	19.5	22	25	28
SW [mm]	10	10	14	17	17	13

ADAPTERS + COMPENSATION MODULES

OVERVIEW OF SERIES



▶ **ADAPTERS + COMPENSATION MODULES**



Series F - Compensation Modules

32



Series FV - Compensation Modules

33

ADAPTERS + COMPENSATION MODULES

SERIES F

► SERIES F - COMPENSATION MODULES



► Special features

- External thread
- Spring loaded compensator
- Vacuum connection
- Rotation prevention available

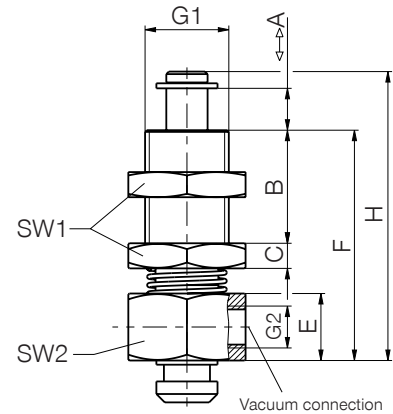

► Technical Data

Order no.	FA	FB	FC	FD	FE
Fixing types	4	5	1	3	2
G1	M5	M8x1	M10x1	M12x1	M12x1
G2	M5	M5	M5	M5	M5
Dimension A [mm]	4	4	5	10	10
Dimension B [mm]	8	10	13.5	13	13
Dimension C [mm]	3	3	3	4	4
Dimension E [mm]	7	8	8	8	8
Dimension F [mm]	21	24.2	27.5	29	29
Dimension H [mm]	27	30	34.5	41	41
SW1 [mm]	8	10	14	17	17
SW2 [mm]	10	10	14	17	17

► ROTATION PREVENTION

► Technical Data

Order no.	FA1	FB1	FC1	FD1
Suitable for	FA	FB	FC	FD/FE

► SERIES FV - COMPENSATION MODULES WITH VACUUM GENERATORS



► Special features

- External thread
- Spring loaded compensator
- Integrated vacuum generators
- Rotation prevention available

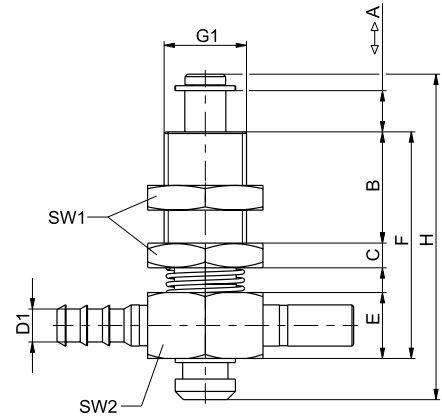

► Technical Data

Order no.	FAV	FBV	FCV	FDV	FEV
Fixing types	4	5	1	3	2
Air consumption per min. [l norm]	13	13	13	13	13
G1	M5	M8x1	M10x1	M12x1	M12x1
Dimension A [mm]	4	4	5	10	10
Dimension B [mm]	8	10	13.5	13	13
Dimension C [mm]	3	3	3	4	4
Dimension D1 [mm]	2.8	2.8	4	4	4
Dimension E [mm]	7	8	8	8	8
Dimension F [mm]	21	24.2	27.5	29	29.1
Dimension H [mm]	27	30	34.5	41	41
SW1 [mm]	8	10	14	17	17
SW2 [mm]	10	10	14	17	17

► ROTATION PREVENTION

► Technical Data

Order no.	FA1	FB1	FC1	FD1
Suitable for	FAV	FBV	FCV	FDV/FEV

COMPENSATION MODULES

OVERVIEW OF SERIES

The ideal situation of suction application is a flat surface. In many cases this doesn't exist in practice. To adjust the suction cups axially and radially to the conditions of the suction process, axial adjustment elements are needed. Those elements assure an optimal fit of the suction cups even at work pieces with free formed surfaces. So, the highest possible suction power is reacted.





Suction cups being equipped with a sprung compensating element have the advantage that the suction cups touch the work piece advanced, before the handling device reaches its end position. This allows a higher cycle time due to the fact that the vacuum can be generated before the end position is reached. Furthermore, spring plungers are damping the fitted joints and are compensating differences in level which can arise from indefinable depositing positions respectively collecting positions. If suction cups with a not rotation-symmetrically shape are used, spring plungers with rotation protection devices are preferred.

In combination with ball joints, spring plungers can compensate additional angle errors. Such a combination is applied if pliable work pieces are dealt with. In such cases, the ball joints prevent that the suction cups tears before or after lifting the hanging work piece. A further application are the work pieces with inclined plane where the ball joints guarantee the ideal alignment of the suction cups. If the work piece has to be additionally adjusted after the suction process, an element has to be applied SAG. This angular alignment readjusts automatically into its starting position by using a rubber-metal unit as a joint.





► **COMPENSATION MODULES**

	Series FS - Compensation Modules	36
	Series FSV - Compensation Modules	36
	Series SAG - Compensation Modules	37
	Series SAK - Compensation Modules	37
	Series KG - Ball Joints	39

COMPENSATION MODULES

SERIES FS / SA

► SERIES FS - COMPENSATION MODULES



► Special features

- Spring plunger with damping spring
- High-strength plunger rod
- Smooth compensation of height differences

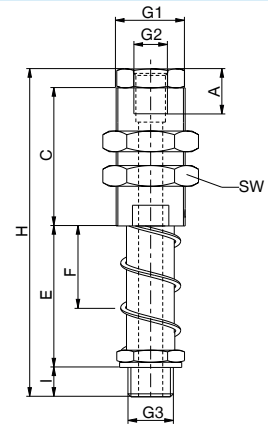

► Technical Data

Order no.	FS14A-25	FS18A-15
G1	M20x1,5	M16x1
G2	G1/8"	G1/8"
G3	G1/4"	G1/8"
Dimension A [mm]	13	8
Dimension C [mm]	40	30
Dimension E [mm]	40.5	29.5
Dimension F [mm]	25	15
Dimension H [mm]	86	73.5
Dimension I [mm]	8.5	6.5
SW [mm]	24	22

► SERIES FSV - COMPENSATION MODULES - ROTATION PREVENTED



► Special features

- Spring plunger with damping spring
- High-strength plunger rod
- Smooth compensation of height differences

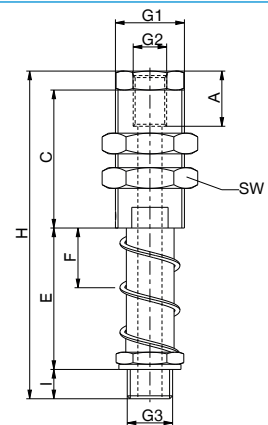

► Technical Data

Order no.	FS14A-25V	FS18A-15V
G1	M20x1,5	M16x1
G2	G1/8"	G1/8"
G3	G1/4"	G1/8"
Dimension A [mm]	13	8
Dimension C [mm]	40	30
Dimension E [mm]	40.5	28.5
Dimension F [mm]	25	15
Dimension H [mm]	86	73.5
Dimension I [mm]	8.5	6.5
SW [mm]	24	22

► SERIES SAG - COMPENSATION MODULES



► Special features

- Mounting jointed on all sides
- Rubber/metal combination as joint
- Very strong material combination
- Automatic return to neutral starting position

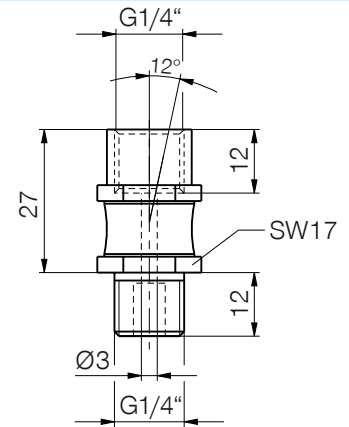

► Technical Data

Order no.	SAG14AI
Fixing thread	G1/4"
Compensation stroke max. [°]	12
SW [mm]	17

► SERIES SAK - COMPENSATION MODULES



► Special features

- Mounting jointed on all sides for suction grippers and suction plates
- Suction grippers and suction plates
- Low rotation point on suction gripper

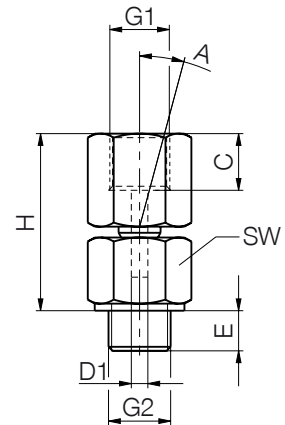

► Technical Data

Order no.	SAK14AI	SAK18AI
Compensation stroke max. [°]	15	15
G1	G1/4"	G1/8"
G2	G1/4"	G1/8"
Dimension C [mm]	12	8.5
Dimension D1 [mm]	3.5	2
Dimension E [mm]	10	7
Dimension H [mm]	37.5	26.5
SW [mm]	19	14

COMPENSATION MODULES

BALL JOINTS - SERIES KG

▶ PRODUCT ADVANTAGES



SOMMER
automatic **S**

▶ Lockable displacement position

Be flexible in your application, customise the handling to your workpiece and lock the displacement position with process reliability

▶ Large locating flange

The large mounting surface simplifies your design and allows secure attachment of add-on components

▶ Steel design

The highest force and torque measurement enables flexible for maximum dynamics

▶ THE BEST PRODUCT FOR YOUR APPLICATION



▶ Our products love the challenge!

Extreme conditions, all over the world—our tried and tested components and systems give you limitless possibilities:

Find the best product for your specific use:

www.zimmer-group.com

▶ PRODUCT SPECIFICATIONS



▶ Forces and moments

Shows static forces and torques which may impact on the ball joint

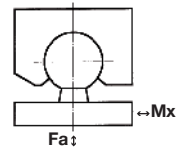

▶ Technical Data

Order no.	KG40	KG40ST	KG60	KG60ST	KG80	KG80ST
Swivel angle [°]	30	30	30	30	30	30
Mx [Nm]	18	18	55	55	124	124
Fa [N]	7500	18000	15000	45000	28000	70000
Weight [kg]	0.1	0.3	0.3	0.9	0.8	2.3

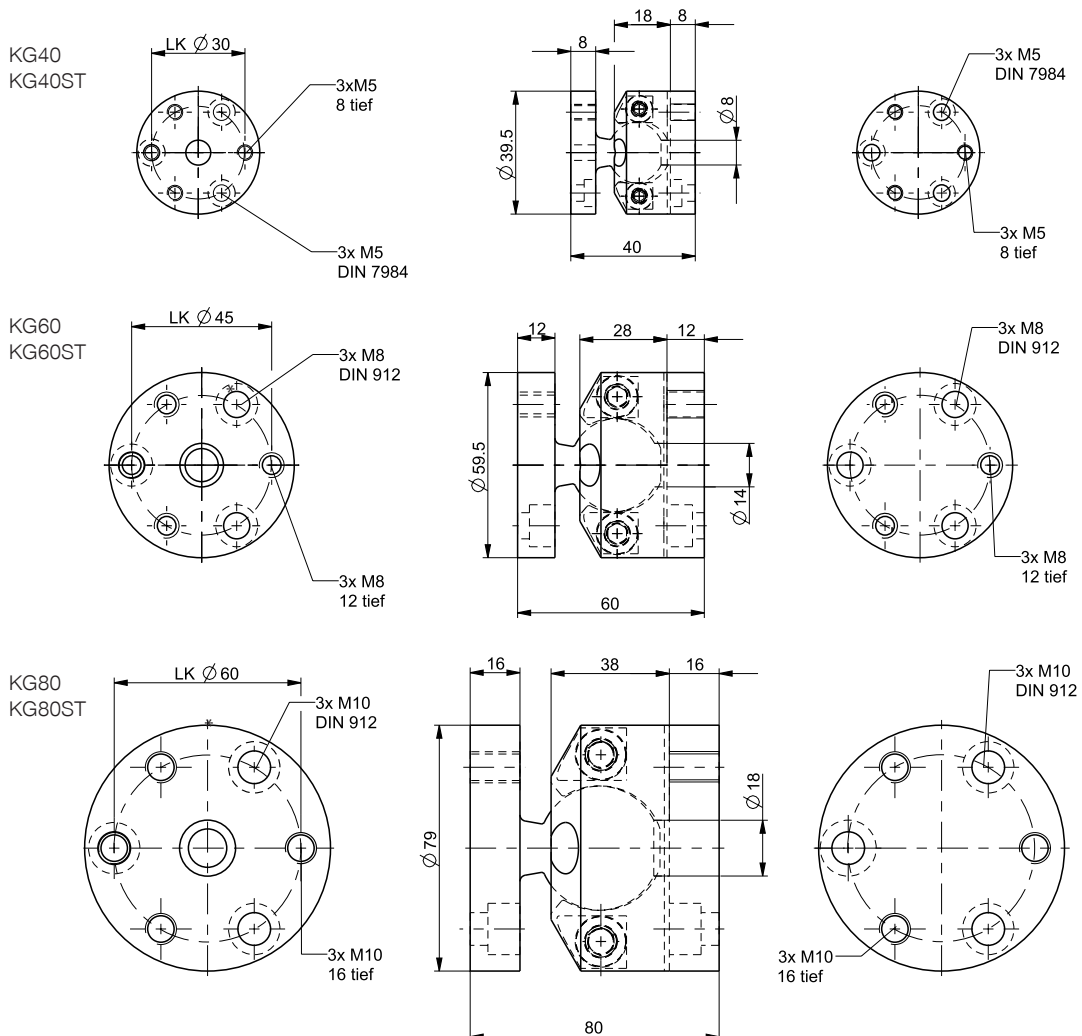





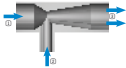

VACUUM GENERATORS

OVERVIEW OF SERIES



▶ VACUUM GENERATORS

	Compact ejectors	42
	Series KEM10 - Compact ejectors	44
	Series KE15 - Compact ejectors	46
	Series KE25 - Compact ejectors	48
	Series VGM - Vacuum generators	50
	Series VG - Vacuum generators	50
	Series VIP - Vacuum generators	51

VACUUM GENERATORS

COMPACT EJECTORS

The units of the series KEM and KE are equipped with an integrated valve technology. They possess beside the normally open suck valve [1] also a normally closed exhaust valve [2] which guarantees a process secure releasing of the suction cups from the work piece.

Furthermore, the process security is increased while using integrated vacuum switches [3], which have an optional electronic (NOE) or digital design (NOD). This switch serves for controlling the vacuum and can also contribute in combination with the automatic air saver to reduce significantly operating expenses.

The filter unit [5] prevents the intrusion of foreign particles into the ejector and therefore, increases the service life of the unit.

The muffler [4] serves for noise reduction of the compact ejectors. It is especially advisable if several ejectors are used. They can be mounted parallelly on an adapter plate which also is available optionally.

The exact selection of an appropriate vacuum generator for your specific application depends on various factors. The amount and size of the suction cups as well as the features and conditions play a vital role of the handling work piece.



The following table makes it easier to select the suitable ejector and it shows the required suction capability depending on the suction diameter. The specified values are applied per suction cups and for smooth, vacuum sealed material. For porous, coarsely porous or rough surfaces generally tests should be carried out to determine the suction capability.

► Pumping speed vs diameter of the suction cup

Suction cup Ø	Pumping speed Vs	
up to 60 mm	0,5 m ³ /h	8,3 l/min
up to 120 mm	1,0 m ³ /h	16,6 l/min

The ejectors of the series KE allow the application of the optional available automatic air saver. In connection with the vacuum switch, which is installed in the ejector, a customer-specific defined vacuum range (hysteresis) is controlled and regulated. This control allows a reduction of the air to a multiple compared to conventional-controlled ejectors (see graph). Due to the fact that the ejector does not permanently generate vacuum, but only if the pre-set threshold is under-run.

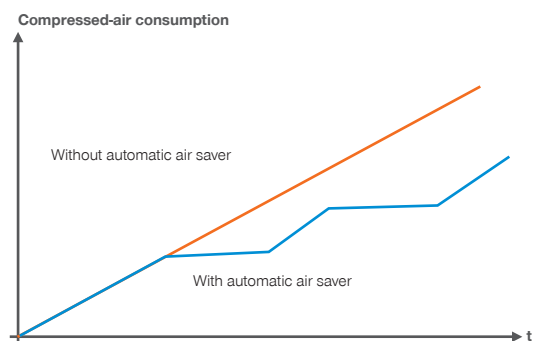

VACUUM GENERATORS

VENTURI NOZZLE AND MULTI-STAGE EJECTORS

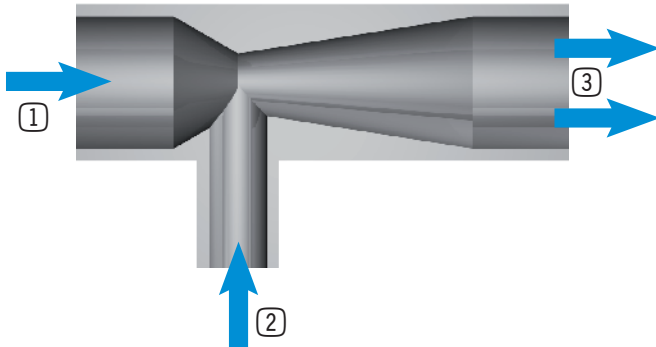

VENTURI NOZZLE

The venturi principle cannot only be found in compact ejectors but also in in-line vacuum generators VGM and VG as well as in the adapter series SAV and FV.

According to the venturi principle, the fitted nozzle [1] in the ejector aims to conduct compressed air. With the reduction of the diameter in the interior the streaming air accelerates. Thus, a vacuum arises at the die exit [2]. Compressed air and sucked back ambient air are released via the exhaust air [3]. The generated vacuum is in relation to the used compressed air.

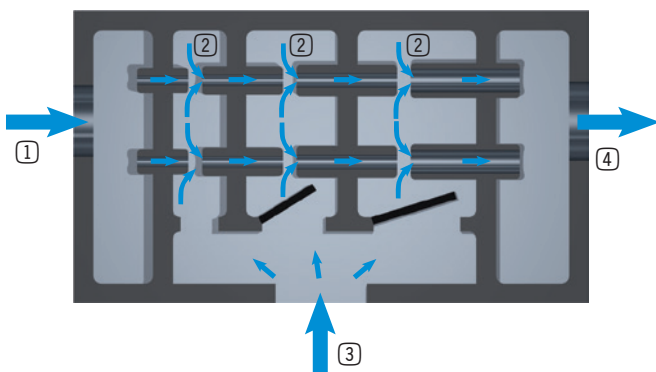

MULTI-STAGE EJECTORS

In addition to the single-stage venturi principle, multi-stage ejectors are implemented for vacuum generators of the series VIP. In this option, multiple venturi nozzles are connected in series. With the connection [1,] compressed air is conducted into the ejector and streams through the fitted nozzles [2]. The arising vacuum sucks air via the vacuum connection [3]. The vacuum capacity of single nozzles is added in this way. The result is a much higher pumping speed compared to single-stage ejectors. Compressed air and sucked ambient air are released via the exhaust air [4].

VACUUM GENERATORS

COMPACT EJECTORS - SERIES KEM10

▶ PRODUCT SPECIFICATIONS



▶ Special features

- Complete solution for easiest installation
- Minimum installation size, low weight
- Integrated valve technology and vacuum monitoring
- Wide range of outputs
- Normally open suction valve

▶ EJECTORS/VACUUM GENERATORS

Pumping speed at different vacuum levels

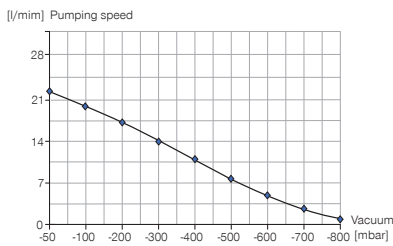

Evacuation time for different vacuum levels

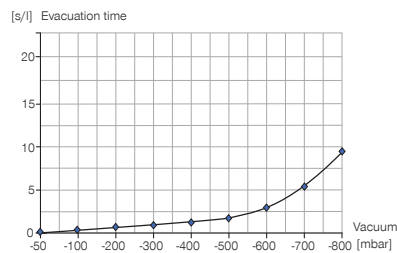

Reachable vacuum of different operating pressure

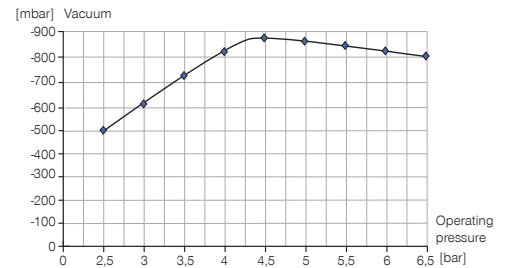

▶ RECOMMENDED ACCESSORIES



Straight Fittings - Quick Connect Style

GVM5



Plug-in connector Straight Cable 5m - Socket M8 (female)

KAG500B4



Connecting cable

ZUB0040

Order no.	Technical Data
	KEM10NOE
Nozzle diameter [mm]	1
Vacuum level [%]	85
Max. suction capacity [l/min]	23
Max. suction capacity [m ³ /h]	1.4
Air consumption suction [l/min]*	46
Air consumption suction [m ³ /h]*	2.8
Air consumption blowing [l/min]	26
Noise level (suction) [db(A)]	73
Noise level (free-running) [db(A)]	76
Operating pressure [bar]	4.5
Recommended inner hose Ø compressed air [mm]**	2.0
Recommended inner hose Ø vacuum [mm]**	4.0
Operating temperature [°C]	0 ... +45
Weight [kg]	0.08

*at 5 bar operating pressure

**at max. 2m Length

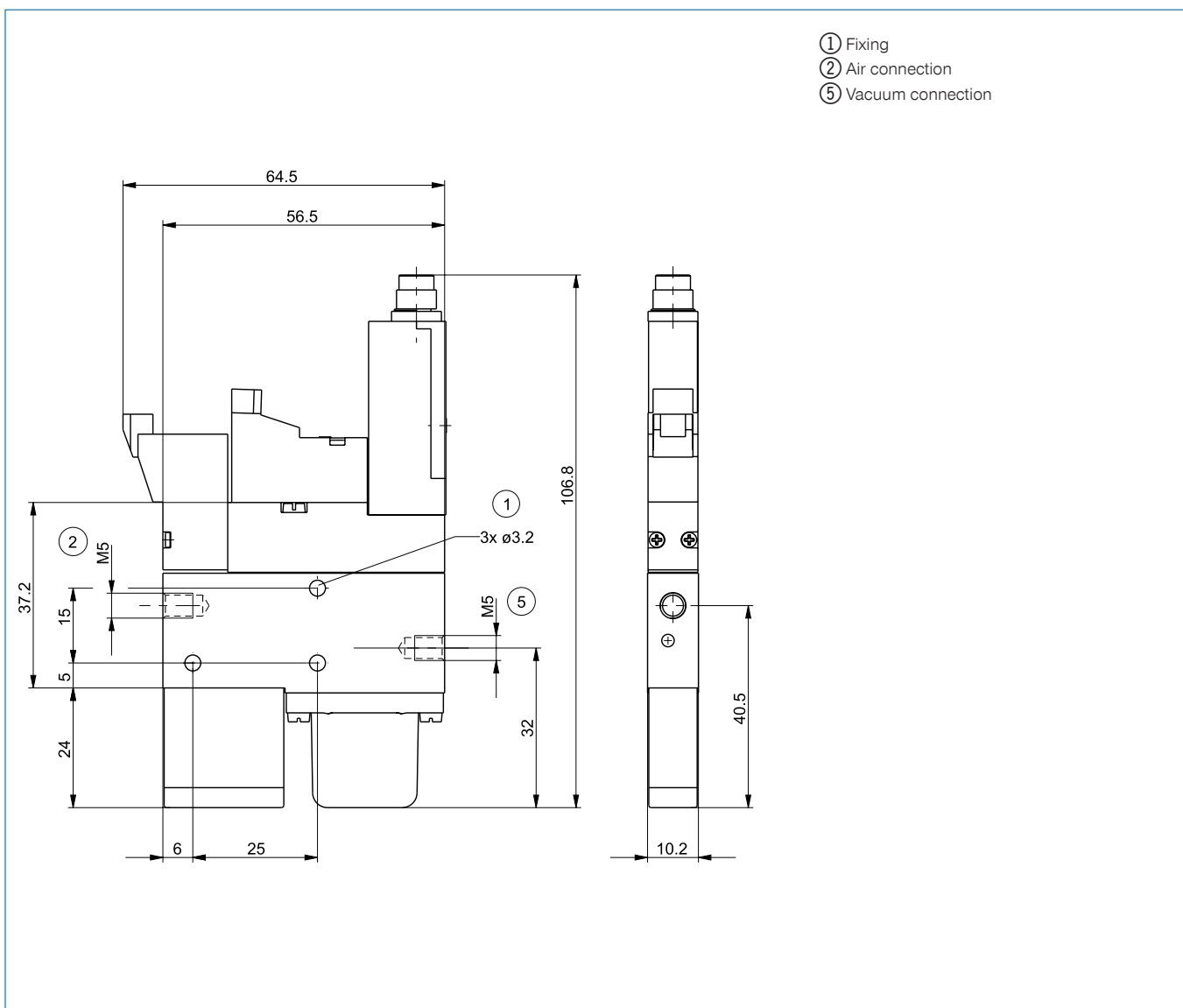

VACUUM GENERATORS

COMPACT EJECTORS - SERIES KE15

▶ PRODUCT SPECIFICATIONS



▶ Special features

Air consumption optimized by finely adjustable suction capacity

Electronic vacuum switch (KE15NOE)

Digital vacuum switch (KE15NOD)

Significantly reduced compressed air consumption using optional air saving technology

▶ EJECTORS/VACUUM GENERATORS

Pumping speed at different vacuum levels

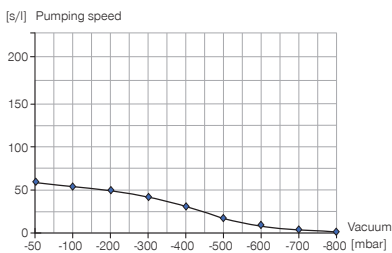

Evacuation time for different vacuum levels

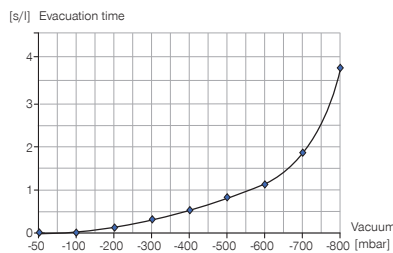

Reachable vacuum of different operating pressure

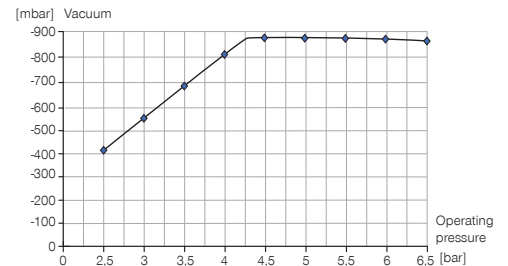

▶ RECOMMENDED ACCESSORIES



Straight Fittings - Quick Connect Style

GV1-8X6



Straight Fittings - Quick Connect Style

GV1-8X8



Plug-in connector Straight Cable 5m - Socket M8 (female)

KAG500B4



Connecting cable

ZUB0040



Air Saving Function

ZUB0005



Air Connection 4-Connections

ZUB0008

Order no.	Technical Data	
	KE15NOD	KE15NOE
Nozzle diameter [mm]	1.5	1.5
Vacuum level [%]	85	85
Max. suction capacity [l/min]	65	65
Max. suction capacity [m ³ /h]	3.9	3.9
Air consumption suction [l/min]*	117	117
Air consumption suction [m ³ /h]*	7	7
Air consumption blowing [l/min]	200	200
Noise level (suction) [db(A)]	68	68
Noise level (free-running) [db(A)]	68	68
Operating pressure [bar]	5	5
Recommended inner hose Ø compressed air [mm]**	4	4
Recommended inner hose Ø vacuum [mm]**	6	6
Operating temperature [°C]	0 ... +45	0 ... +45
Weight [kg]	0.275	0.275

*at 5 bar operating pressure

**at max. 2m Length

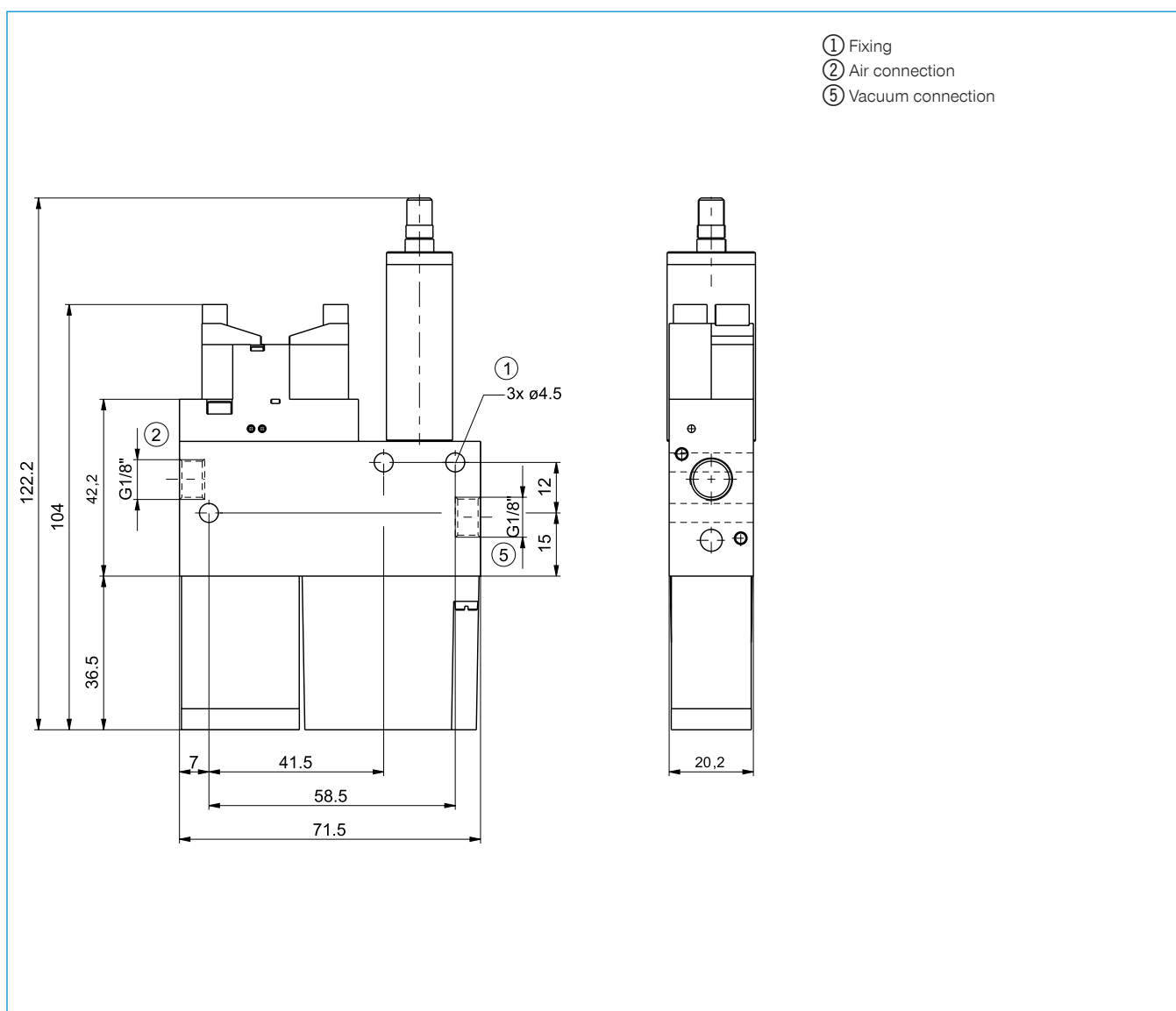

VACUUM GENERATORS

COMPACT EJECTORS - SERIES KE25

▶ PRODUCT SPECIFICATIONS



▶ Special features

- Air consumption optimized by finely adjustable suction capacity
- Electronic vacuum switch (KE25NOE)
- Digital vacuum switch (KE25NOD)
- Significantly reduced compressed air consumption using optional air saving technology

▶ EJECTORS/VACUUM GENERATORS

Pumping speed at different vacuum levels

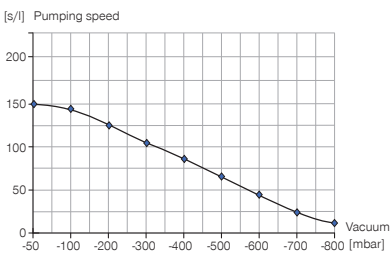

Evacuation time for different vacuum levels

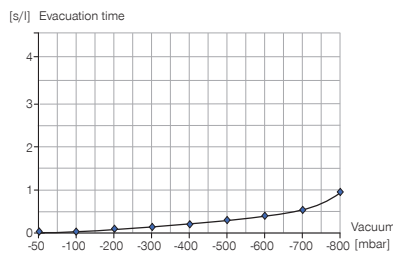

Reachable vacuum of different operating pressure

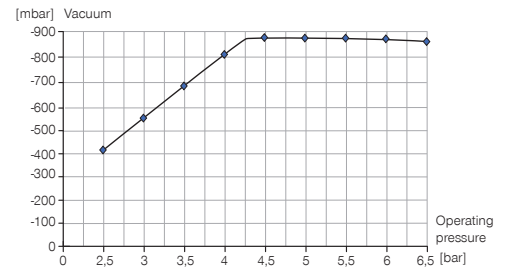

▶ RECOMMENDED ACCESSORIES



Straight Fittings - Quick Connect Style

GV1-4X8



Straight Fittings - Barb Style Connection

GV3-8X13ID



Plug-in connector Straight Cable 5m - Socket M8 (female)

KAG500B4

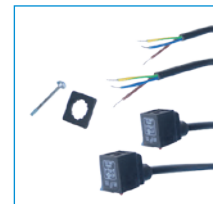

Connecting cable

ZUB0041



Air Saving Function

ZUB0006



Air Connection 4-Connections

ZUB0011

Order no.	Technical Data	
	KE25NOD	KE25NOE
Nozzle diameter [mm]	2.5	2.5
Vacuum level [%]	85	85
Max. suction capacity [l/min]	161	161
Max. suction capacity [m³/h]	9.7	9.7
Air consumption suction [l/min]*	310	310
Air consumption suction [m³/h]*	18.6	18.6
Air consumption blowing [l/min]	200	200
Noise level (suction) [db(A)]	72	72
Noise level (free-running) [db(A)]	82	82
Operating pressure [bar]	5 ... 6	5 ... 6
Recommended inner hose Ø compressed air [mm]**	6	6
Recommended inner hose Ø vacuum [mm]**	9	9
Operating temperature [°C]	0 ... +45	0 ... +45
Weight [kg]	0.485	0.485

*at 5 bar operating pressure

**at max. 2m Length

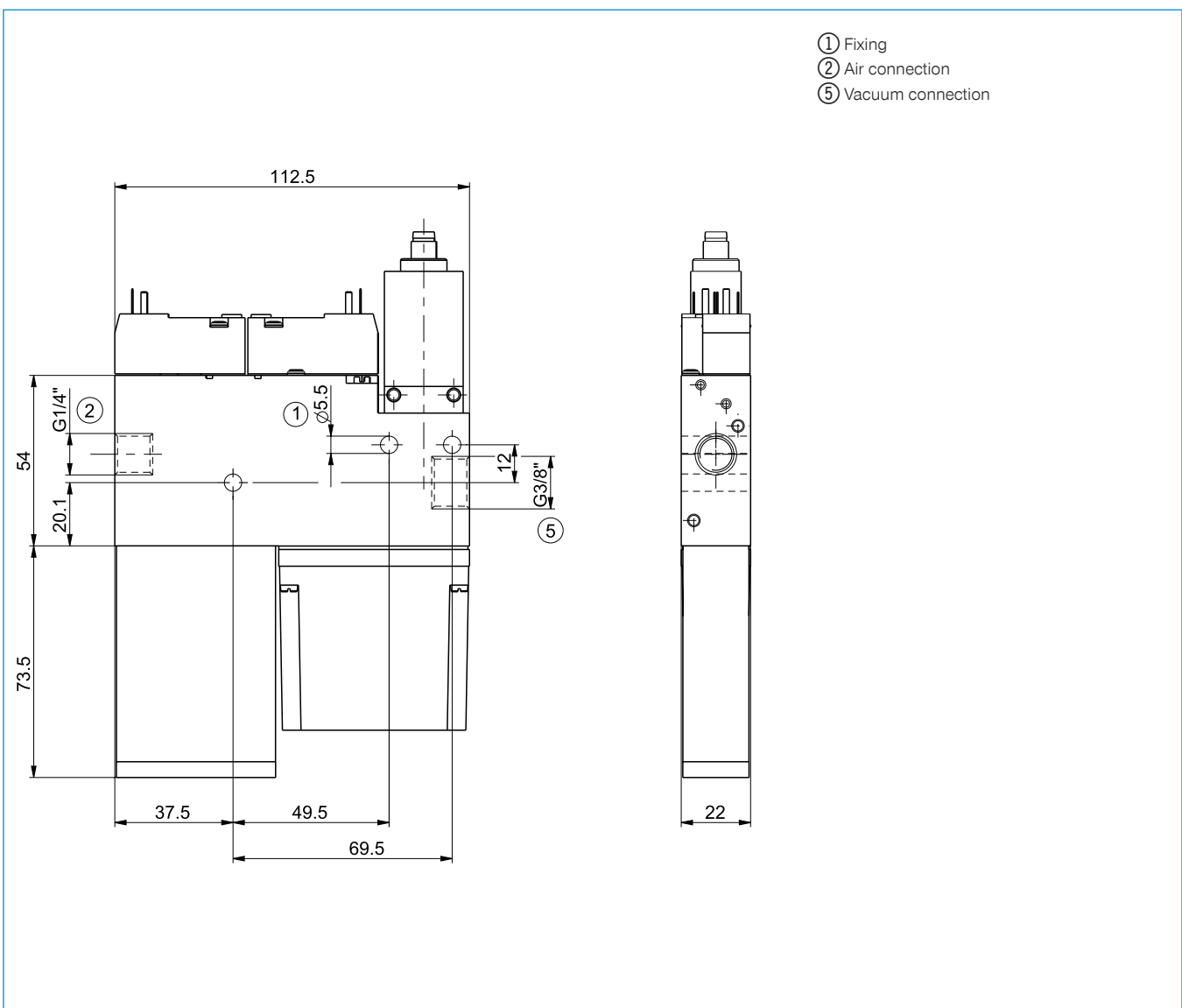

VACUUM GENERATORS

SERIES VGM / VG / VIP

► SERIES VGM



► Special features

- Integrated vacuum connection ⑤
- Compressed air connection ②
- Exhaust air ④

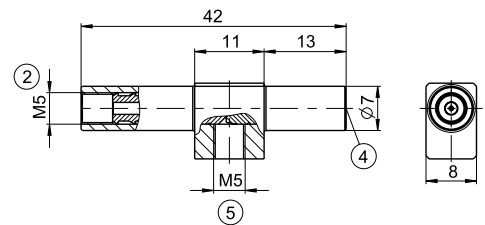

► Technical Data

Order no.	VGM5
Vacuum [bar]	-0.8
Air consumption per min. [l norm]	63
Fixing thread	M5

► SERIES VG



► Special features

- Integrated vacuum connection ⑤
- Compressed air connection ②
- Connection for silencer Order no. SD18KS ⑧

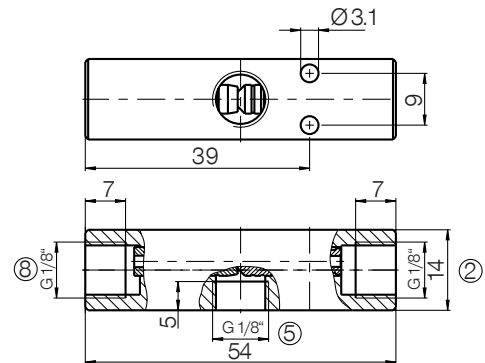

► Technical Data

Order no.	VG1-8
Vacuum [bar]	-0.8
Air consumption per min. [l norm]	63
Fixing thread	G1/8"

► SERIES VIP



► Note

Manometer order no. VM62, suitable for VIP4 to VILP16, is not supplied with product

► Technical Data

Order no.	VIP4	VIP8	VIP12	VILP16
Vacuum output at 4 bar [%]	90	90	90	90
Air consumption per min. [l norm]	63	126	240	240
Vacuum volume [l norm/min.]	165	320	590	350
Operating pressure [bar]	4 ... 7	4 ... 7	4 ... 7	4 ... 7
Noise level (free-running) [db(A)]	65	65	65	75
Noise level (suction) [db(A)]	50	50	50	55
Operating temperature [°C]	-20 ... +80	-20 ... +80	-20 ... +80	-10 ... +100
A	G1/2"	G1/2"	G1/2"	G1,5"
Dimension B [mm]	67	67	67	97
Dimension C [mm]	29	29	29	
Dimension D [mm]	182	182	182	250
Dimension E [mm]	34	34	52	47
Weight [kg]	0.67	0.7	0.92	2.5

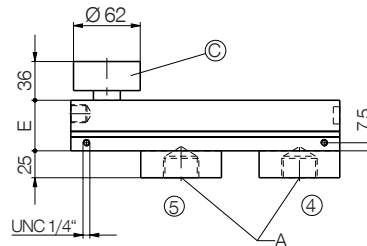
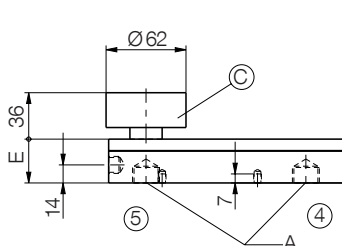
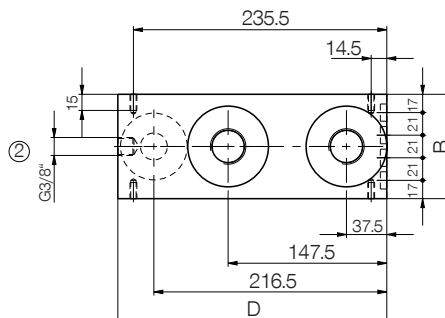
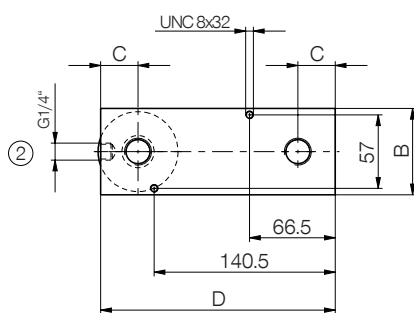

- ② Air connection
- ④ Exhaust air
- ⑤ Vacuum connection
- Ⓒ Manometer is not supplied with product
Order no. VM62

SENSING UNITS

OVERVIEW OF SERIES

To guarantee a secure operation of the vacuum circuit, measuring equipment and control devices are inevitable. These components have to meet highest quality requirements so that ejectors and suction cups fulfil their tasks perfectly. Thus, vacuum switches and vacuum controllers play an essential role.



Components for system monitoring can be found in all areas of automated handling processes. No matter if automotive or plastics industry or other applications where process reliability needs to be increased, sensing units are required.

Due to their high switching accuracy and switching frequencies, electronic vacuum switches suit applications where a long life-time and high precision is the priority. Further benefits of the electronic switch are their small size and increased ease of use. Different parameters can be programmed and evaluated via plastic foil keyboard and LCD display. Vacuum switches can be used within a measuring range of -1 to 0 bar.







With mechanic adapters of series SAV / SAM it is possible to integrate a compact and simple work piece identification. Via a plunger and a proximity switch the work piece availability can be monitored.





▶ SENSING UNITS

	Series SAM	54
	Series SAVM	54
	Series VS001	55
	Series VS003E	56
	Series VS003D	57

SENSING UNITS

SERIES SAM / SAVM / VS

► SERIES SAM



► Special features

- External thread
- Vacuum connection ⑤
- Matches proximity switch NJ3-E2 ⑨
- Integrated plunger to detect workpiece ⑩

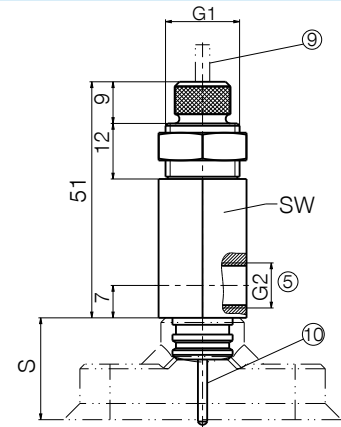

► Technical Data

Order no.	SAM14X1	SAM16X1
Fixing types	1	1
G1	M14x1	M16x1
G2	M5	G1/8"
S [mm]*	12	21
SW [mm]	17	19

*consider Dimension „S“ (maximal distance of suction cup to assure an accurate sensing result)

► SERIES SAVM



► Special features

- External thread
- Integrated vacuum generator
- Compressed air connection ⑤
- Matches proximity switch NJ3-E2 ⑨
- Integrated plunger to detect workpiece ⑩

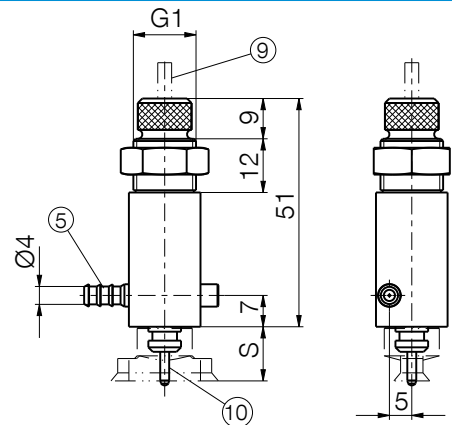

► Technical Data

Order no.	SAVM14X1	SAVM16X1
Vacuum [bar]	-0.8	-0.8
Fixing types	1	2
Air consumption suction [l norm]	12	14
Max. suction capacity [l/min]	3	2
Vacuum level [%]	80	78
Operating pressure [bar]	6	6
G1	M14x1	M16x1
S [mm]*	12	21

*consider Dimension „S“ (maximal distance of suction cup to assure an accurate sensing result)

► SERIES VS001



► Special features

- Switching points adjustable via teach button
- Two digital switching outputs
- Vertical or horizontal fixing
- Electronic vacuum sensor
- 200 mA switching circuit

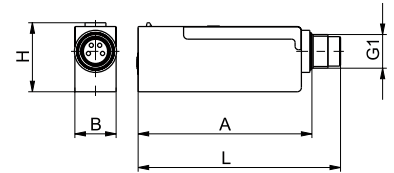

► Technical Data

Order no.	VS001EL-E2	VS001ES-E2
Measuring medium	non-aggressive gases; dry, oil-free air	non-aggressive gases; dry, oil-free air
Measuring range [bar]	-1...0	-1...0
Max. safe overpressure [bar]	5	5
Repetition accuracy [%]	+/- 1% from measuring range	+/- 1% from measuring range
Hysteresis fest [mbar]	20	20
Output signal	2 digital	2 digital
Switching capacity [mA]	200	200
Status indication	LED	LED
Electrical connection	Connector M8, 4-pole	Connector M8, 4-pole
Voltage [V DC]	10-30	10-30
Current consumption [mA]	20	20
Degree of protection [IP]	40	40
Temperature deviation	+/- 3% from measuring range	+/- 3% from measuring range
Allowable ambient temperature [°C]	0...60	0...60
Type	horizontal	vertical
G1	M8	M8
Dimension A [mm]	41.2	36.2
Dimension B [mm]	10	10
Dimension H [mm]	16.4	17.5
Dimension L [mm]	48	43
Weight [kg]	6	6

SENSING UNITS

SERIES VS

► SERIES VS003E



► Special features

- Electronic vacuum switch
- Switching point and hysteresis adjustable
- Analog and digital outputs

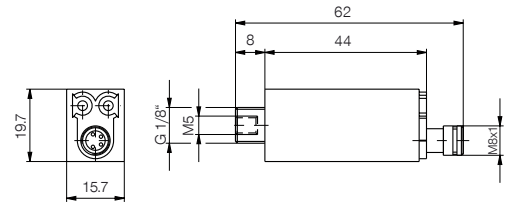

► Technical Data

Order no.	VS003E-E2
Measuring medium	non-aggressive gases; dry, oil-free air
Measuring range [bar]	-1...0
Max. safe overpressure [bar]	5
Repetition accuracy [%]	+/- 1% from measuring range
Hysteresis	Adjustable: 3-25% of the set value
Output signal	1 analog 1..5V / 1 digital
Switching capacity [mA]	125
Response time [ms]	5.0
Status indication	LED
Electrical connection	Connector M8, 4-pole
Connection media	G1/8" -AG + M5-IG
Voltage [V DC]	10.8-30
Current consumption [mA]	30
Degree of protection [IP]	40/65 (with tube)
Temperature deviation	+/- 3% from measuring range
Allowable ambient temperature [°C]	0...50
Weight [kg]	18

► SERIES VS003D



► Special features

- Electronic vacuum switch with digital display
- Switching point and hysteresis freely programmable
- Special programmable functions
- Two separately programmable digital outputs

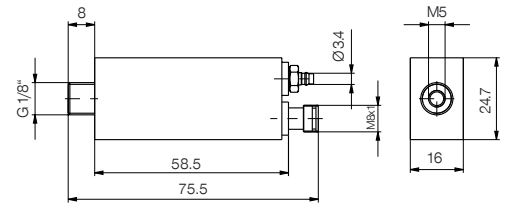

► Technical Data

Order no.	VS003D-E2
Measuring medium	non-aggressive gases; dry, oil-free air
Measuring range [bar]	-1...0
Max. safe overpressure [bar]	5
Repetition accuracy [%]	+/- 1% from measuring range
Hysteresis	adjustable: 0-100% of the set value/comparator mode
Output signal	2 digital
Switching capacity [mA]	180
Status indication	2xLED
Display resolution	0.01 bar, 5 mmHg, 0.2 inHg, 1 kPa
Displayed units	bar, mmHg, inHg, kPa
Displayed value	3-digital 7-segment LED
Electrical connection	Connector M8, 4-pole
Connection media	G1/8" -AG + M5-IG
Voltage [V DC]	10.8-30
Current consumption [mA]	30
Degree of protection [IP]	40/65 (with tube)
Temperature deviation	+/- 3% from measuring range 0-50°C
Allowable ambient temperature [°C]	0...50
Weight [kg]	25

HANDLING COMPONENTS

OVERVIEW OF SERIES

























In vacuum handling applications, not only the suction cups which touch the work piece play an important role, but also the downstream handling components. With the combination of these standardized products, suction cups can be used more efficiently. Thus, they increase the value added in the process.

With the short stroke cylinders of the SH and SHD series, a linear movement of the suction cup is possible, which even can be sensed at the final position. With the integrated venturi nozzle and the simple connection of the suction cups of connection type 1 and 2, the short stroke cylinders can be integrated into the application with a great benefit at little costs. The corresponding nozzles are available as accessory.

Retractable axes of the series SWM were developed for removal handling. An increased torque at the end positions guarantees highest process security while removal of the work pieces. The end position of a 90° tilting can be detected / monitored via magnetic field sensors.

To enhance the rationality of expensive production machines, a flexible production process has to be ensured. This can be realized by the tool changers of the series HWR with an integrated fluid. They guarantee a fast and low-cost changing of various vacuum grippers without any additional tool. Optionally available energy elements allow additionally the transmission of electrical signals.



▶ COMPACT LINEAR CYLINDER		
	Series SH	61
	Series SHD	63
▶ ANGLE PIVOT UNITS		
	Installation size SWM1035	64
	Installation size SWM1045	66
	Installation size SWM1054	68
	Installation size SWM1063	70
▶ TOOL CHANGERS MANUAL		
	Installation size HWR2031	72
	Installation size HWR2040	74
	Installation size HWR2050	76
	Energy elements for tool changers Series HWR2000	78
	Installation size HWR63	80
	Installation size HWR80	82
	Energy elements for tool changers Series HWR	84
▶ 2-JAW PARALLEL GRIPPERS		
	Installation size GPP1104	88
	Installation size GPP1108	90
	Installation size GPP1116	92
▶ 2-JAW ANGULAR GRIPPERS		
	Installation size GZ1020	96
	Installation size GZ1030	98
	Installation size GZ1040	100
▶ CUTTING TONGS		
	Installation size ZK1030	102
	Installation size ZK1036	104
	Installation size ZK1045	106
	Installation size ZK1065	108
	Cutting inserts	110

HANDLING COMPONENTS

COMPACT LINEAR CYLINDERS - SERIES SH

▶ PRODUCT SPECIFICATIONS



▶ Note

SH cylinder can be combined with suction cups via nozzles

ZUB0028 - Fixing type 2

ZUB0029 - Fixing type 1

▶ Special features

Integrated venturi nozzle for vacuum generation

▶ RECOMMENDED ACCESSORIES



Nozzle

ZUB0028



Nozzle

ZUB0029



Mounting block

KB3M



Inductive proximity switch
- Cable 5 m

NJ3-E2



Flow Control Valves - with
Swivel joint

DRVM5X4

Order no.	▶ Technical Data*			
	SH7	SH15	SH25	SH50
Stroke [mm]	7	15	25	50
Pressure force max. [N]	170	170	170	170
Retraction force [N]	100	100	100	100
Air volume per cycle [cm ³]	4	9	15	30
Operating temperature [°C]**	5 ... 80	5 ... 80	5 ... 80	5 ... 80
Weight [kg]	0.09	0.1	0.13	0.18

* All data measured at 6 bar

** High-temperature-resistant model (up to 150°C) add T to part number

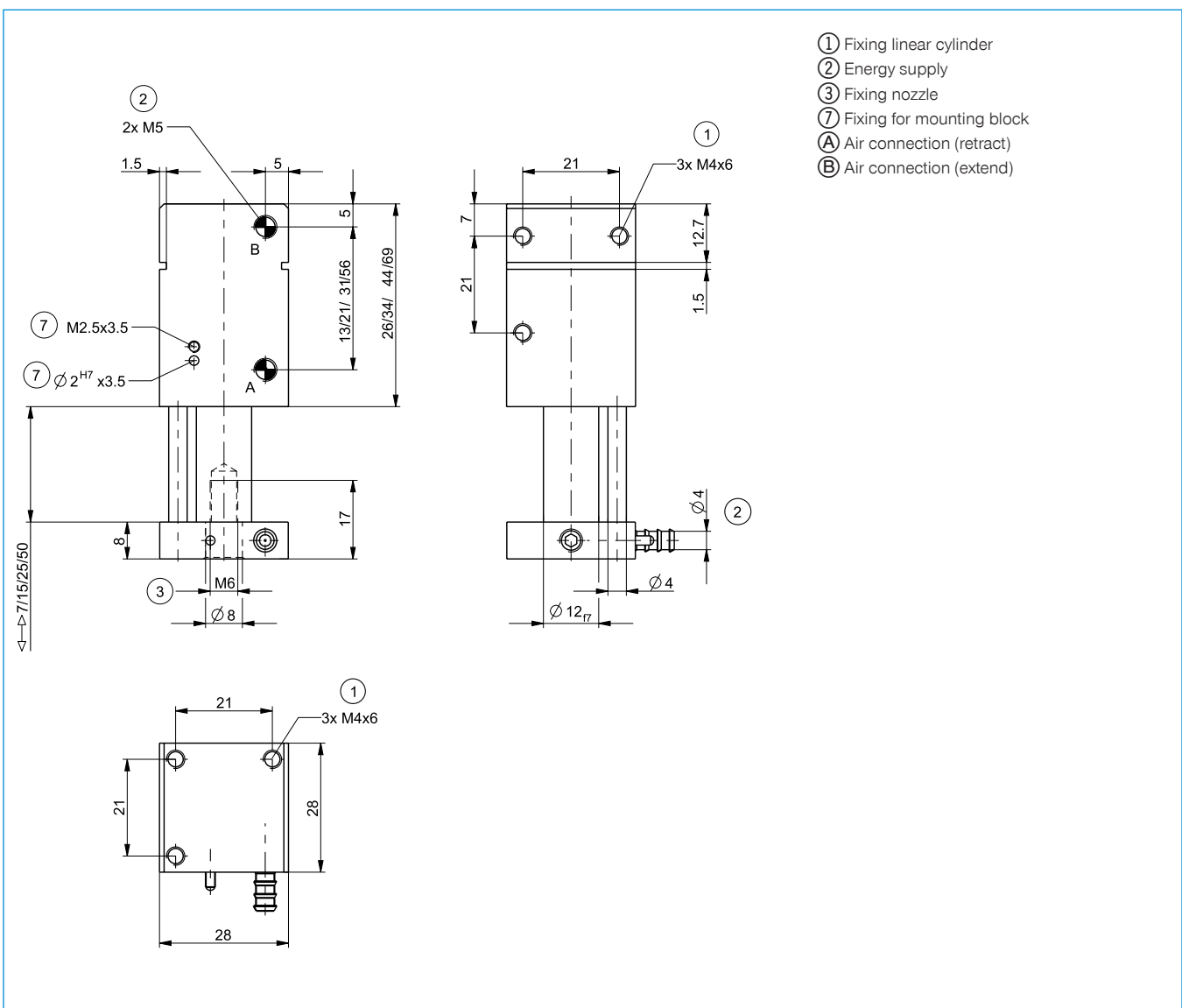

HANDLING COMPONENTS

COMPACT LINEAR CYLINDERS - SERIES SHD

▶ PRODUCT SPECIFICATIONS



▶ Note

SH cylinder can be combined with suction cups via nozzles

ZUB0028 - Fixing type 2

ZUB0029 - Fixing type 1

▶ Special features

Integrated venturi nozzle for vacuum generation

▶ RECOMMENDED ACCESSORIES



Nozzle

ZUB0028



Nozzle

ZUB0029



Mounting block

KB3M



Inductive proximity switch
- Cable 5 m

NJ3-E2



Flow Control Valves - with
Swivel joint

DRVM5X4

Order no.	▶ Technical Data*	
	SHD25	SHD50
Stroke [mm]	25	50
Pressure force max. [N]	100	100
Retraction force [N]	100	100
Air volume per cycle [cm ³]	12	25
Operating temperature [°C]**	5 ... 80	5 ... 80
Weight [kg]	0.19	0.27

*All data measured at 6 bar

**High-temperature-resistant model (up to 150°C) add T to part number

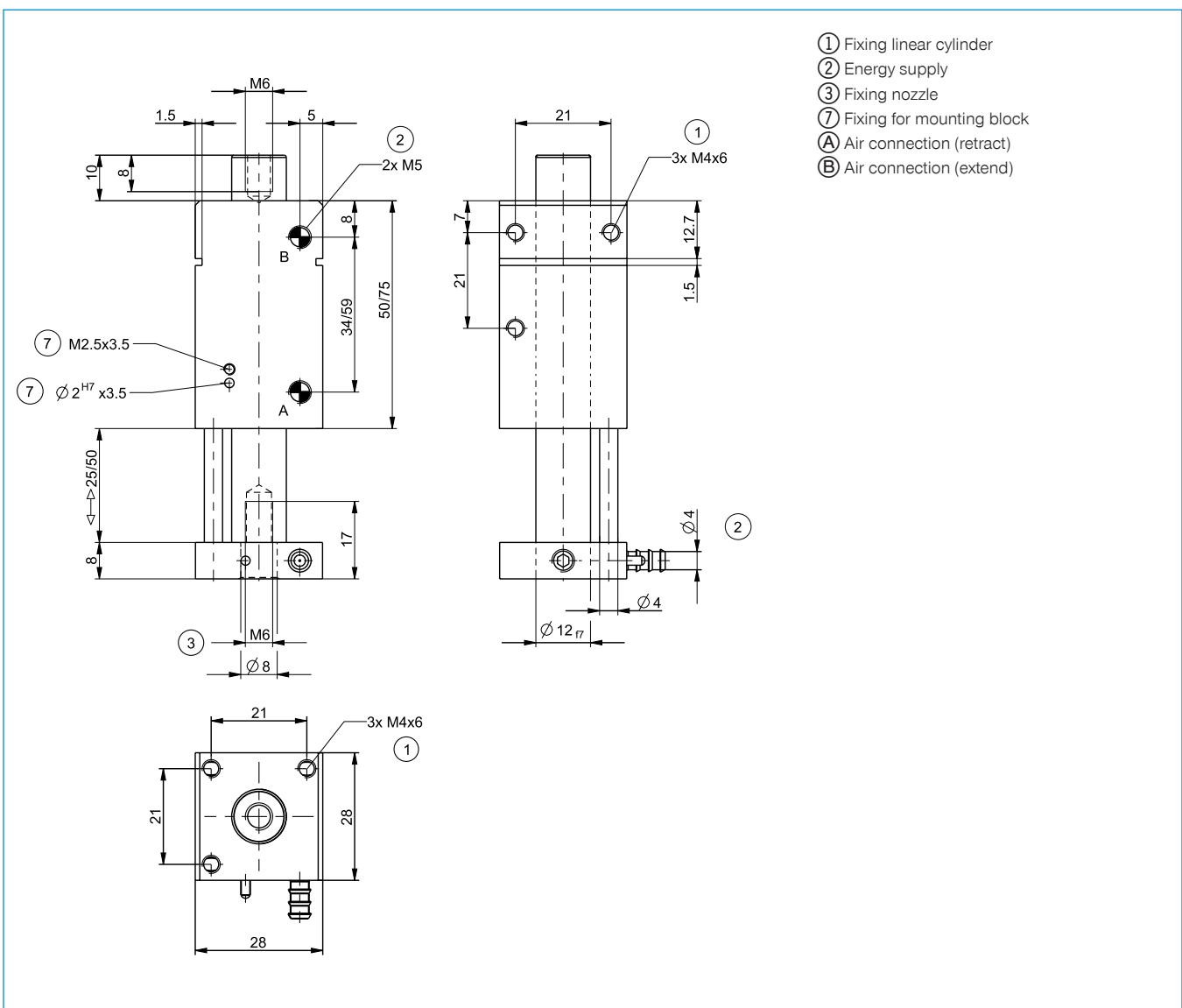

HANDLING COMPONENTS

ANGLE PIVOT UNITS - INSTALLATION SIZE SWM1035

▶ PRODUCT SPECIFICATIONS



▶ Moment of inertia

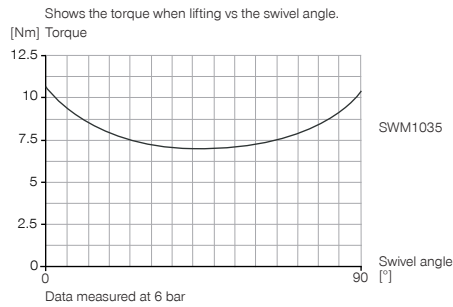

▶ Forces and moments

Indicates the static load on the bearing.

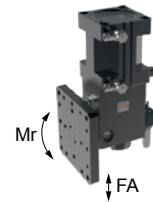

Fa [N]	200
Mr [Nm]	10

▶ INCLUDED IN DELIVERY



Flow Control Valves - with Swivel joint
DRVM5X4



Centering Disc
DST60800

▶ RECOMMENDED ACCESSORIES



Plug-in connector Straight Cable 5m - Socket M8 (female)
KAG500



Plug-in connector Angled Cable 5m - Socket M8 (female)
KAW500



Plug-in connector customizable Straight - Connector M8
S8-G-3



Plug-in connector customizable Straight - Connector M12
S12-G-3

► Technical Data*

Order no.	SWM1035
Swivel angle [°]	90
Swivel angle regulable +/- [°]	3
Torque 0° [Nm]	10
Torque 45° [Nm]	7
Torque 90° [Nm]	10
Repetition accuracy +/- [°]	0.01
Swivel time without extension load [s]	0.3
Operating pressure min. [bar]	3
Operating pressure max. [bar]	8
Operating temperature min. [°C]	5
Operating temperature max. [°C]	+80
Air volume per cycle [cm ³]	55
Weight [kg]	0.65

*All data measured at 6 bar

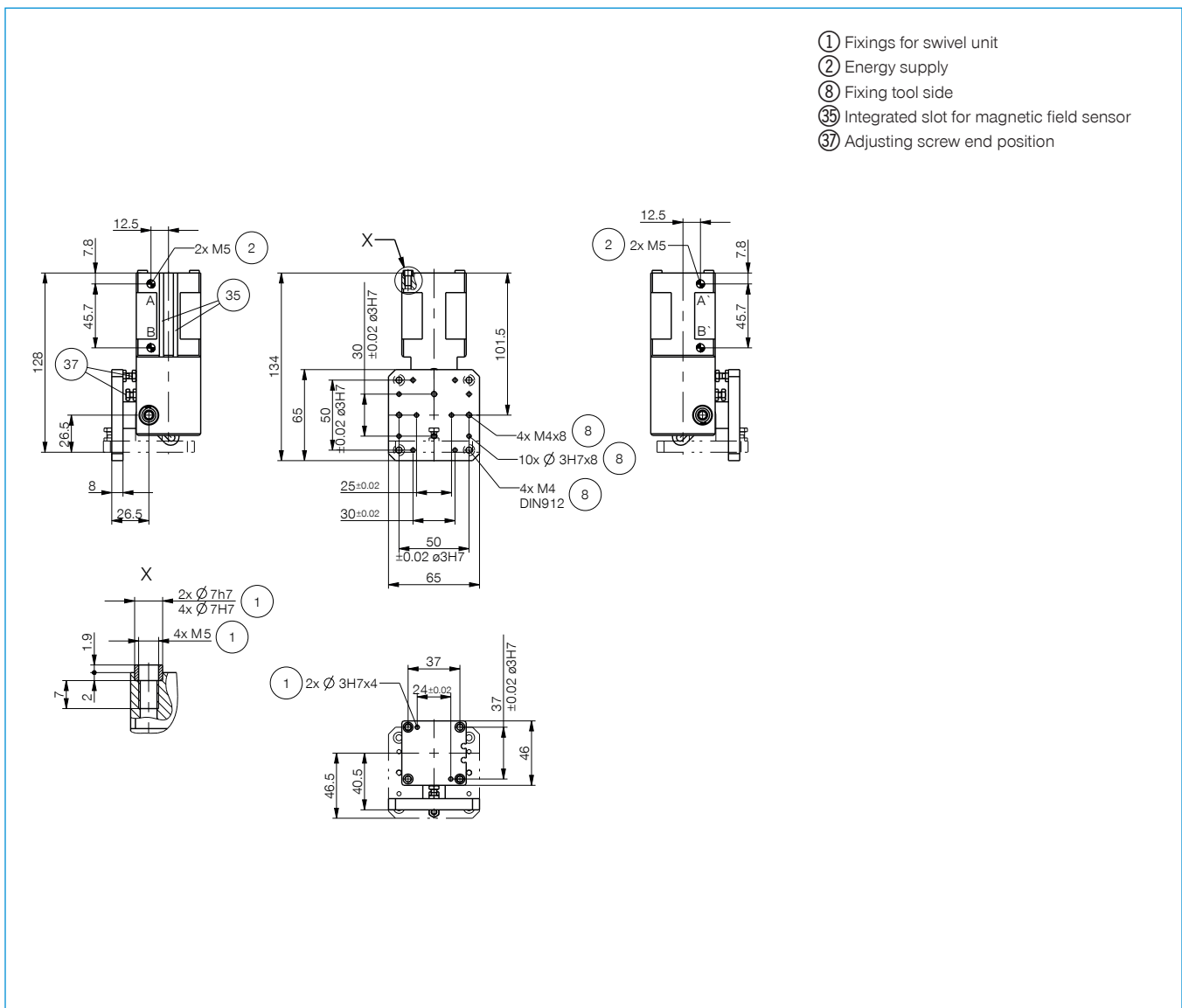

- ① Fixings for swivel unit
- ② Energy supply
- ⑧ Fixing tool side
- ③⑤ Integrated slot for magnetic field sensor
- ③⑦ Adjusting screw end position

HANDLING COMPONENTS

ANGLE PIVOT UNITS - INSTALLATION SIZE SWM1045

▶ PRODUCT SPECIFICATIONS



▶ Moment of inertia

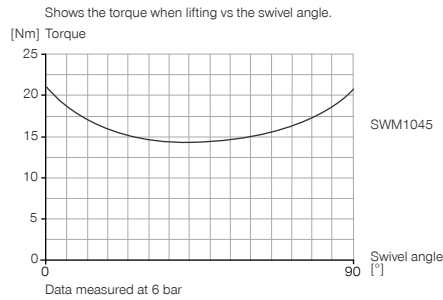

▶ Forces and moments

Indicates the static load on the bearing.

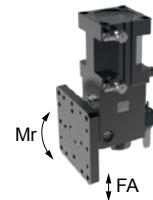

Fa [N]	300
Mr [Nm]	20

▶ INCLUDED IN DELIVERY



Flow Control Valves - with Swivel joint
DRVM5X4



Centering Disc
BDST40800

▶ RECOMMENDED ACCESSORIES



Attachment Kit
ANS0047



Magnetic field sensor
Angled Cable 0,3 m -
Connector M8
MFS103SKHC



Magnetic field sensor
Angled Cable 5 m
MFS103KHC



Magnetic field sensor
Straight Cable 0,3 m -
Connector M8
MFS204SKHC



Magnetic field sensor
Straight Cable 5 m
MFS204KHC

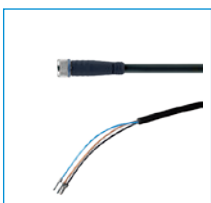

Plug-in connector Straight Ca-
ble 5m - Socket M8 (female)
KAG500



Plug-in connector Angled Ca-
ble 5m - Socket M8 (female)
KAW500



Pressure Safety Valve
DSV1-8



Plug-in connector customiz-
able Straight - Connector M8
S8-G-3



Plug-in connector customiz-
able Straight - Connector M12
S12-G-3

► Technical Data*

Order no.	SWM1045
Swivel angle [°]	90
Swivel angle regulable +/- [°]	3
Torque 0° [Nm]	21
Torque 45° [Nm]	14
Torque 90° [Nm]	21
Repetition accuracy +/- [°]	0.01
Swivel time without extension load [s]	0.4
Operating pressure min. [bar]	3
Operating pressure max. [bar]	8
Operating temperature min. [°C]	5
Operating temperature max. [°C]	+80
Air volume per cycle [cm ³]	110
Weight [kg]	1.2

*All data measured at 6 bar

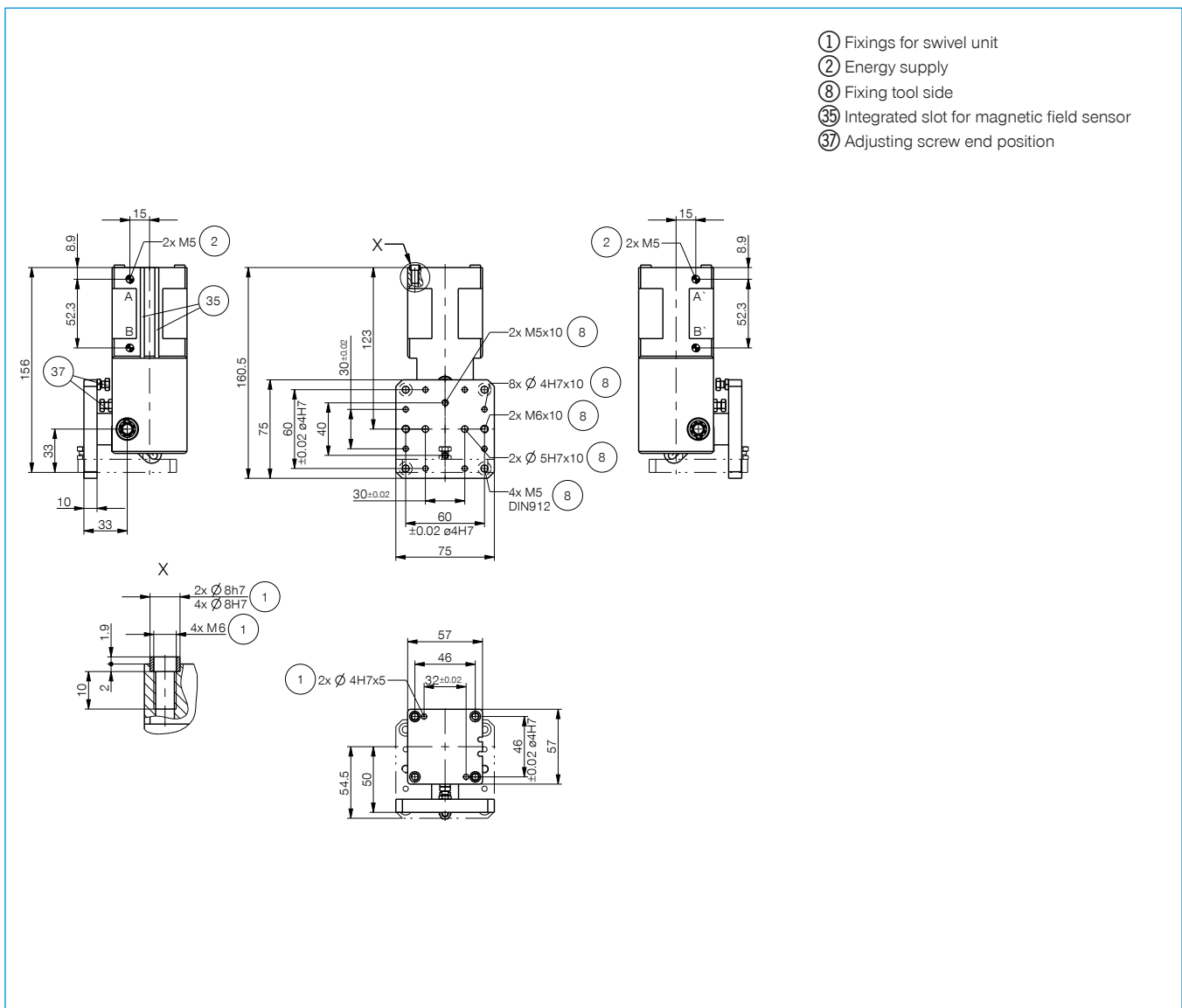

- ① Fixings for swivel unit
- ② Energy supply
- ⑧ Fixing tool side
- ③⑤ Integrated slot for magnetic field sensor
- ③⑦ Adjusting screw end position

HANDLING COMPONENTS

ANGLE PIVOT UNITS - INSTALLATION SIZE SWM1054

▶ PRODUCT SPECIFICATIONS



▶ Moment of inertia

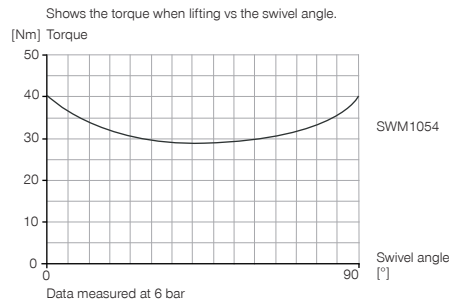

▶ Forces and moments

Indicates the static load on the bearing.

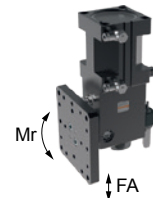

Fa [N]	400
Mr [Nm]	30

▶ INCLUDED IN DELIVERY



Flow Control Valves - with Swivel joint
DRV1-8X6



Centering Disc
DST11500

▶ RECOMMENDED ACCESSORIES



Attachment Kit
ANS0048



Magnetic field sensor Angled Cable 0,3 m - Connector M8
MFS103SKHC



Magnetic field sensor Angled Cable 5 m
MFS103KHC



Magnetic field sensor Straight Cable 0,3 m - Connector M8
MFS204SKHC



Magnetic field sensor Straight Cable 5 m
MFS204KHC

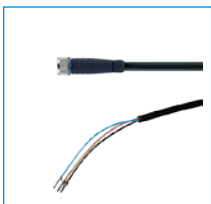

Plug-in connector Straight Cable 5m - Socket M8 (female)
KAG500



Plug-in connector Angled Cable 5m - Socket M8 (female)
KAW500



Pressure Safety Valve
DSV1-8



Plug-in connector customizable Straight - Connector M8
S8-G-3



Plug-in connector customizable Straight - Connector M12
S12-G-3

► Technical Data*

Order no.	SWM1054
Swivel angle [°]	90
Swivel angle regulable +/- [°]	3
Torque 0° [Nm]	40
Torque 45° [Nm]	29
Torque 90° [Nm]	40
Repetition accuracy +/- [°]	0.01
Swivel time without extension load [s]	0.5
Operating pressure min. [bar]	3
Operating pressure max. [bar]	8
Operating temperature min. [°C]	5
Operating temperature max. [°C]	+80
Air volume per cycle [cm ³]	215
Weight [kg]	2.3

*All data measured at 6 bar

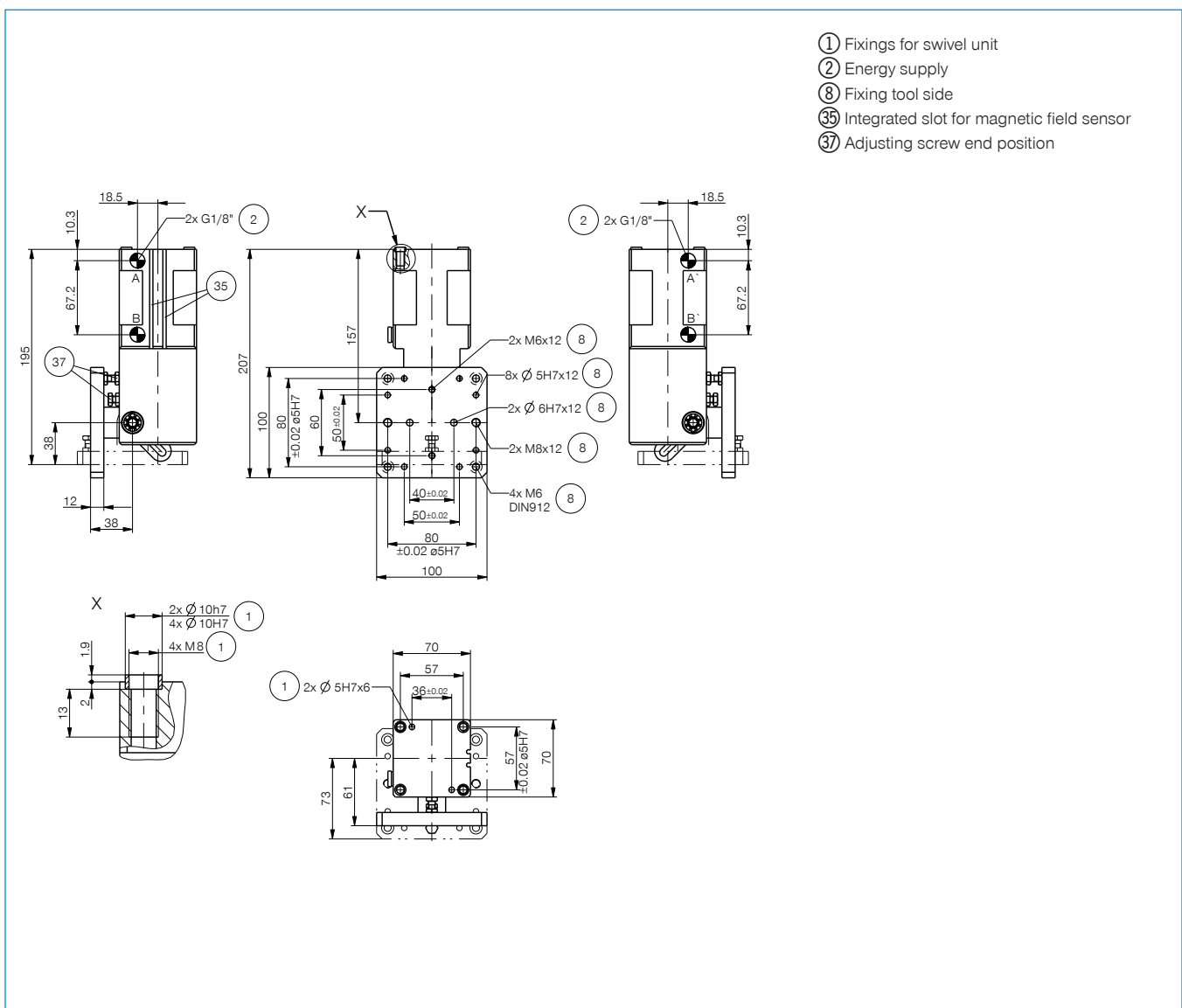

HANDLING COMPONENTS

ANGLE PIVOT UNITS - INSTALLATION SIZE SWM1063

▶ PRODUCT SPECIFICATIONS



▶ Moment of inertia

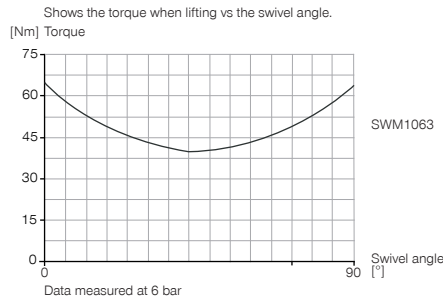

▶ Forces and moments

Indicates the static load on the bearing.

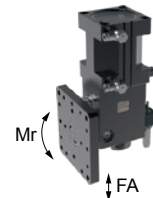

Fa [N]	500
Mr [Nm]	45

▶ INCLUDED IN DELIVERY



Flow Control Valves - with Swivel joint
DRV1-8X6



Centering Disc
DST42000

▶ RECOMMENDED ACCESSORIES



Attachment Kit
ANS0049



Magnetic field sensor Angled Cable 0,3 m - Connector M8
MFS103SKHC



Magnetic field sensor Angled Cable 5 m
MFS103KHC



Magnetic field sensor Straight Cable 0,3 m - Connector M8
MFS204SKHC



Magnetic field sensor Straight Cable 5 m
MFS204KHC

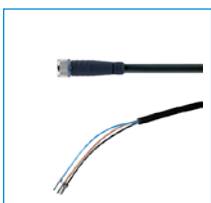

Plug-in connector Straight Cable 5m - Socket M8 (female)
KAG500



Plug-in connector Angled Cable 5m - Socket M8 (female)
KAW500



Pressure Safety Valve
DSV1-8



Plug-in connector customizable Straight - Connector M8
S8-G-3



Plug-in connector customizable Straight - Connector M12
S12-G-3

Order no.	► Technical Data*
Swivel angle [°]	90
Swivel angle regulable +/- [°]	3
Torque 0° [Nm]	64
Torque 45° [Nm]	39
Torque 90° [Nm]	64
Repetition accuracy +/- [°]	0.01
Swivel time without extension load [s]	0.6
Operating pressure min. [bar]	3
Operating pressure max. [bar]	8
Operating temperature min. [°C]	5
Operating temperature max. [°C]	+80
Air volume per cycle [cm ³]	340
Weight [kg]	3.5

*All data measured at 6 bar

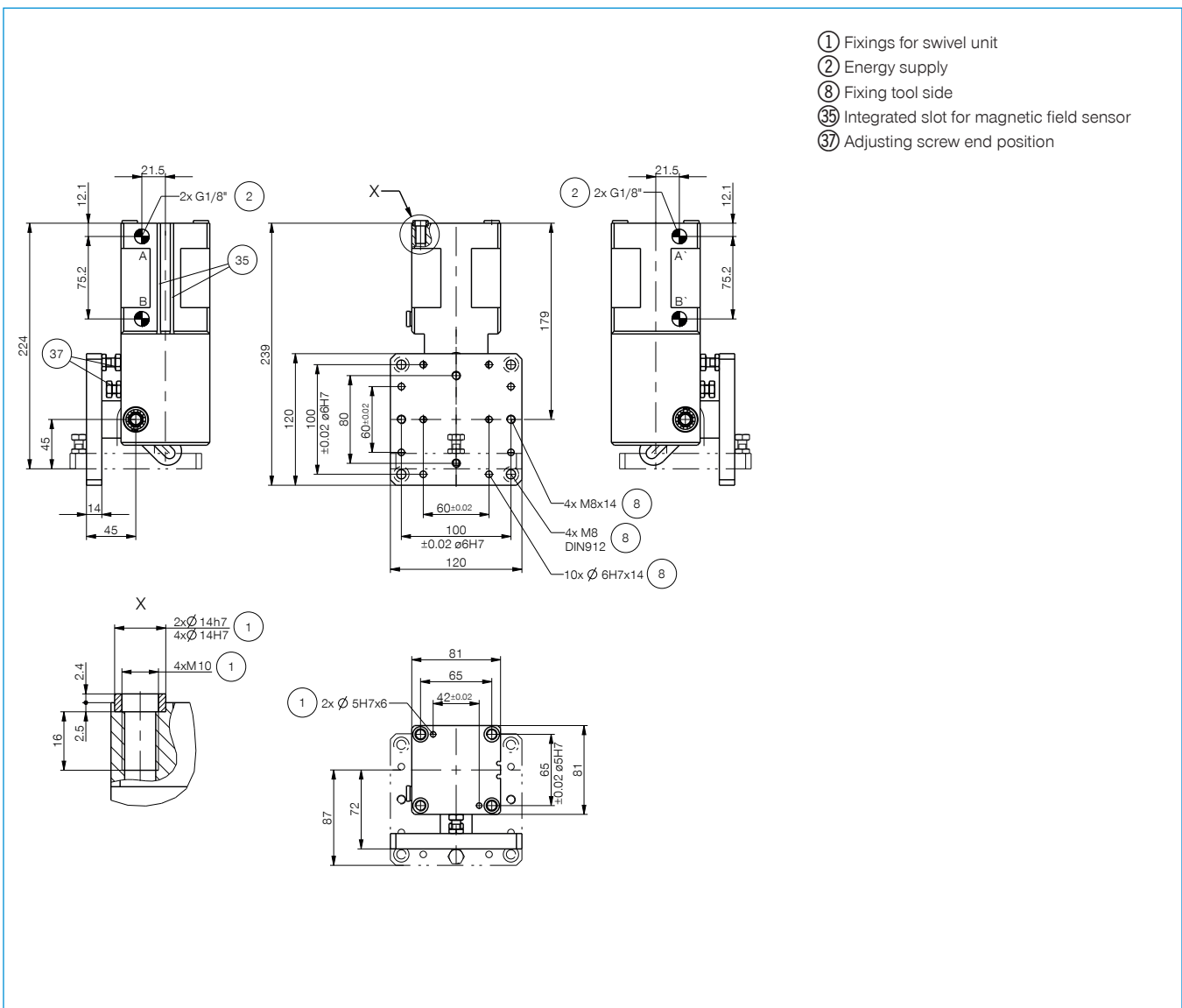

- ① Fixings for swivel unit
- ② Energy supply
- ⑧ Fixing tool side
- ③⑤ Integrated slot for magnetic field sensor
- ③⑦ Adjusting screw end position

HANDLING COMPONENTS

TOOL CHANGERS - INSTALLATION SIZE HWR2031

▶ PRODUCT SPECIFICATIONS



▶ Note

Energy element for current transmission optionally available

▶ Special features

Allows simple and quick change of application without additional tools

Integrated air T vacuum transfer

▶ Forces and moments

Shows static forces and moments which may impact on the tool changer when locked.

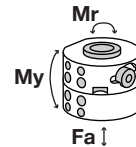

Mr [Nm]	30
My [Nm]	25
Fa [N]	1000

▶ RECOMMENDED ACCESSORIES



Straight Fittings - Quick Connect Style

GVM5



Energy Elements see page 78

Order no.	► Technical Data*	
	HWR2031F	HWR2031L
Connecting flange according EN ISO 9409-1	TK31,5	TK31,5
Recommended handling weight [kg]	5	5
Pneumatic energy transfer [Quantity]**	4	4
Electrical energy transfer	optional	optional
Self limitation when locking	mechanical	mechanical
Locking stroke [mm]	4	
Repetition accuracy in Z [mm]	0.01	0.01
Repetition accuracy in X, Y [mm]	0.02	0.02
Operating temperature min. [°C]	5	5
Operating temperature max. [°C]	+80	+80
Moment of inertia [kg/cm ²]	0.13	0.1
Weight [kg]	0.09	0.04

*All data measured at 6 bar

**Vacuum possible

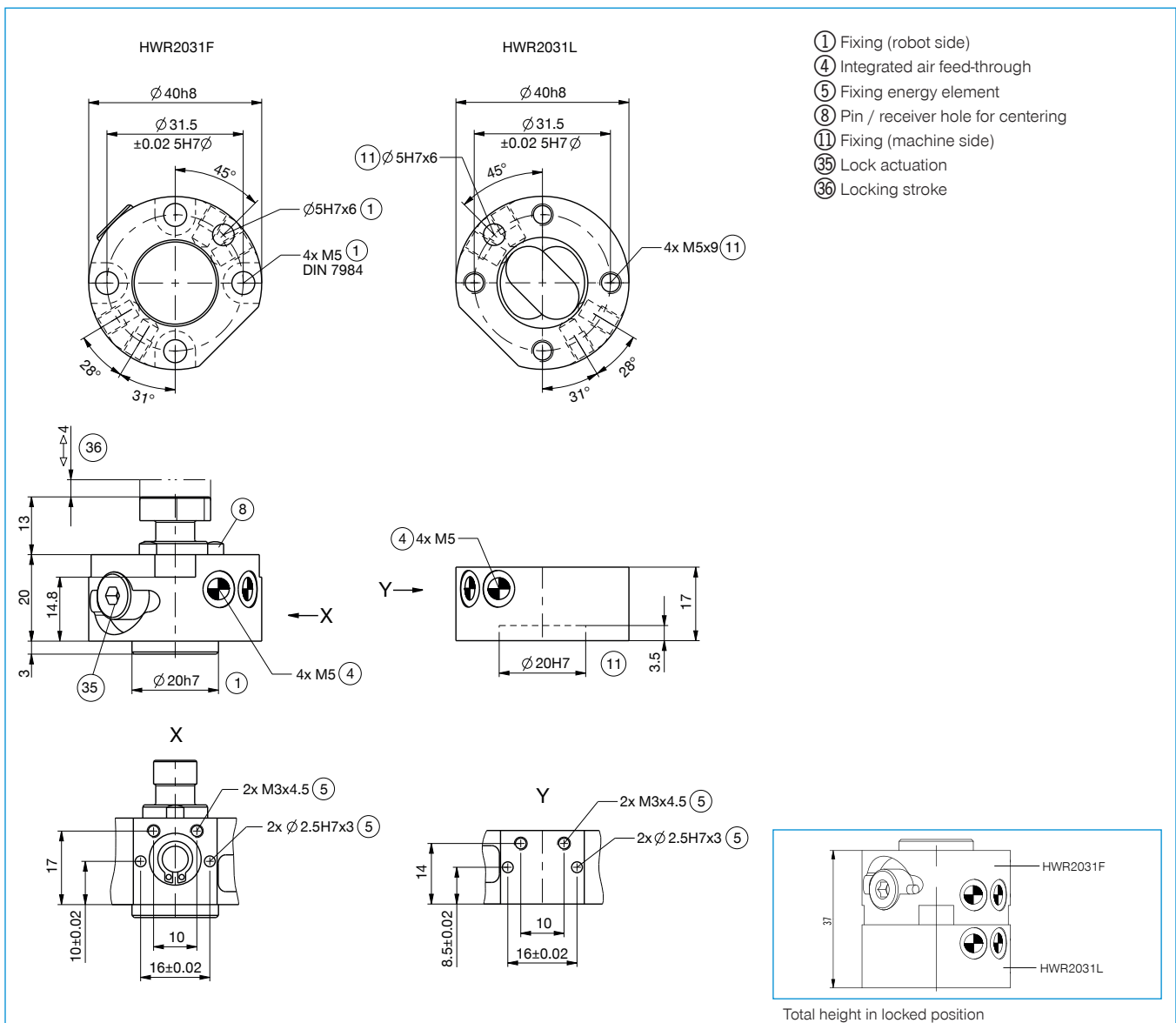

HANDLING COMPONENTS

TOOL CHANGERS - INSTALLATION SIZE HWR2040

▶ PRODUCT SPECIFICATIONS



▶ Note

Energy element for current transmission optionally available

▶ Special features

Allows simple and quick change of application without additional tools

Integrated air T vacuum transfer

▶ Forces and moments

Shows static forces and moments which may impact on the tool changer when locked.

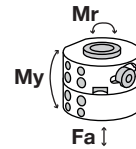

Mr [Nm]	55
My [Nm]	50
Fa [N]	1200

▶ RECOMMENDED ACCESSORIES



Straight Fittings - Quick Connect Style

GVM5



Energy Elements see page 78

Order no.	► Technical Data*	
	HWR2040F	HWR2040L
Connecting flange according EN ISO 9409-1	TK40	TK40
Recommended handling weight [kg]	10	10
Pneumatic energy transfer [Quantity]**	4	4
Electrical energy transfer	optional	optional
Self limitation when locking	mechanical	mechanical
Locking stroke [mm]	4	
Repetition accuracy in Z [mm]	0.01	0.01
Repetition accuracy in X, Y [mm]	0.02	0.02
Operating temperature min. [°C]	5	5
Operating temperature max. [°C]	+80	+80
Moment of inertia [kg/cm ²]	0.33	0.26
Weight [kg]	0.145	0.07

* All data measured at 6 bar

** Vacuum possible

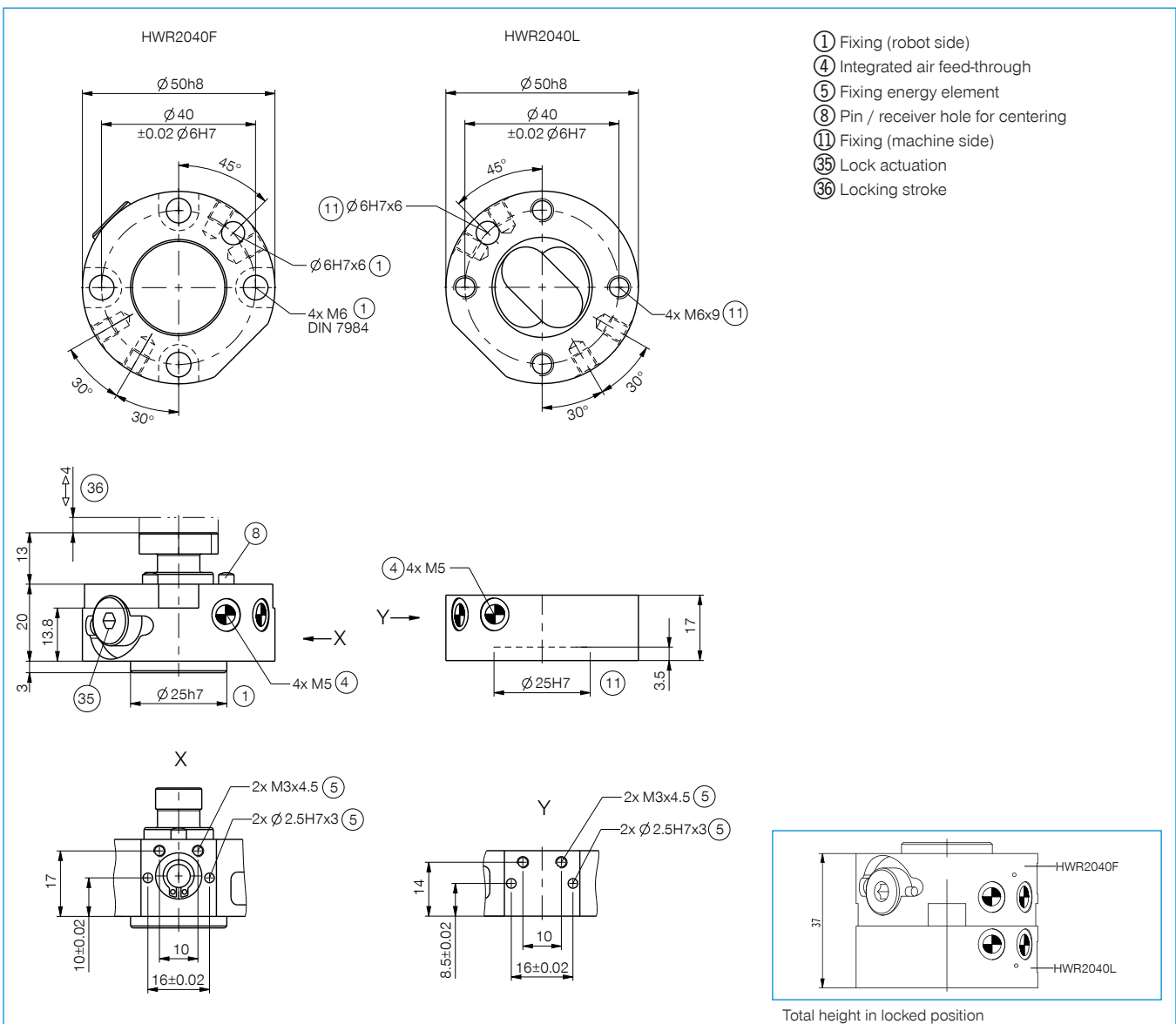

HANDLING COMPONENTS

TOOL CHANGERS - INSTALLATION SIZE HWR2050

▶ PRODUCT SPECIFICATIONS



▶ Note

Energy element for current transmission optionally available

▶ Special features

Allows simple and quick change of application without additional tools

Integrated air T vacuum transfer

▶ Forces and moments

Shows static forces and moments which may impact on the tool changer when locked.

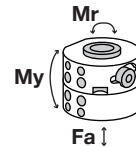

Mr [Nm]	80
My [Nm]	70
Fa [N]	1600

▶ RECOMMENDED ACCESSORIES



Straight Fittings - Quick Connect Style

GVM5



Energy Elements see page 78

Order no.	Technical Data*	
	HWR2050F	HWR2050L
Connecting flange according EN ISO 9409-1	TK 50	TK 50
Recommended handling weight [kg]	20	20
Pneumatic energy transfer [Quantity]**	8	8
Electrical energy transfer	optional	optional
Self limitation when locking	mechanical	mechanical
Locking stroke [mm]	4	
Repetition accuracy in Z [mm]	0.01	0.01
Repetition accuracy in X, Y [mm]	0.02	0.02
Operating temperature min. [°C]	5	5
Operating temperature max. [°C]	+80	+80
Moment of inertia [kg/cm ²]	0.86	0.67
Weight [kg]	0.23	0.115

*All data measured at 6 bar

**Vacuum possible

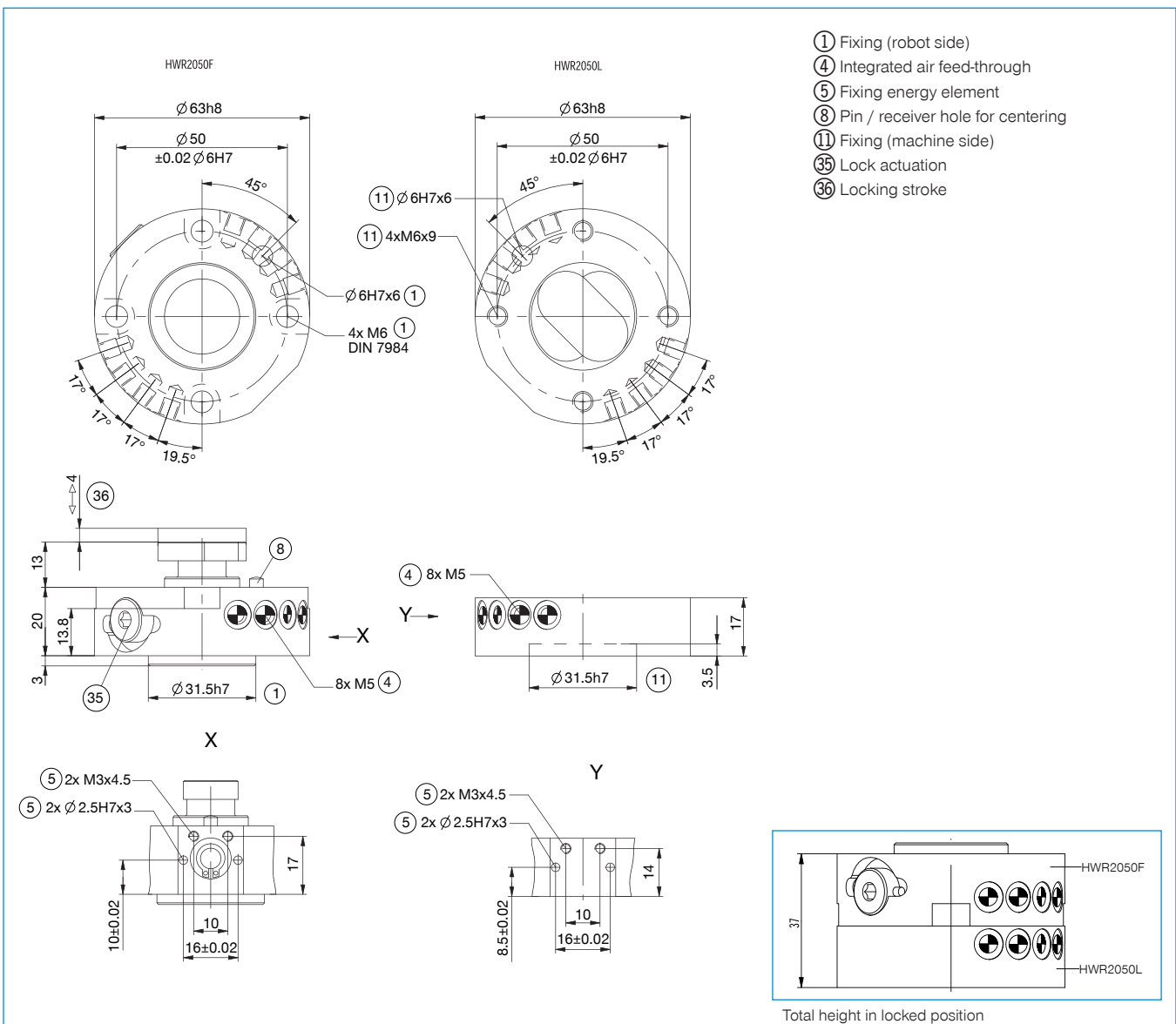

ENERGY ELEMENTS FOR TOOL CHANGER

SERIES HWR2000

▶ PRODUCT SPECIFICATIONS

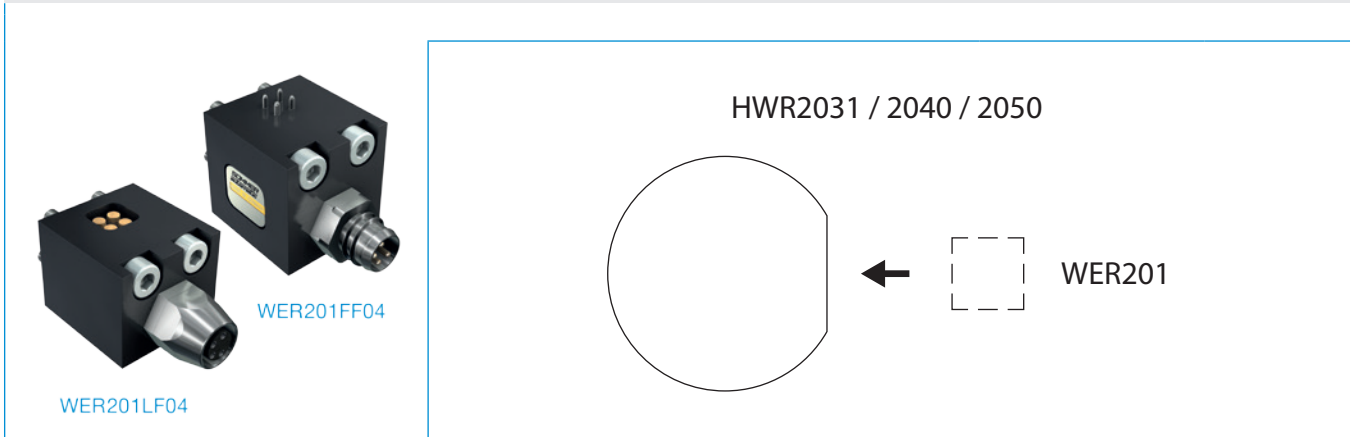

▶ ELECTRICAL

Order no.	▶ Technical Data	
	WER201FF04	WER201LF04
compatible with	Fix part	Loose part
Connection type	Spring contact	Spring contact
Round Connector [Straight] *	KAG500B4	KAG500S4
Round Connector [Angle] *	KAW500B4	KAW500S4
Fixing thread	M8	M8
No. of contacts	4	4
Nominal current [A]	3	3
Supply voltage [V AC]	60	60
Supply voltage [V DC] **	75	75
Weight [kg]	0.03	0.03
Connection type	Male	Female

*als Zubehör erhältlich see page 85

**Specifications for on-site grounding, 60V without grounding

HANDLING COMPONENTS

TOOL CHANGERS - INSTALLATION SIZE HWR63

▶ PRODUCT SPECIFICATIONS



▶ Note

Adapter plate for connection to MCS Modular Construction System optionally available

Energy element for current transmission optionally available

▶ Special features

Allows simple and quick change of application without additional tools

Integrated air T vacuum transfer

▶ Forces and moments

Shows static forces and moments which may impact on the tool changer when locked.

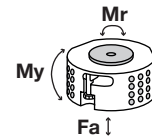

Mr [Nm]	200
My [Nm]	200
Fa [N]	1200

▶ INCLUDED IN DELIVERY



O-Ring

COR0025100

▶ RECOMMENDED ACCESSORIES



Straight Fittings - Quick Connect Style

GVM5



Angled Fittings - Quick Connect Style

WVM5



Energy Elements see page 84

Order no.	▶ Technical Data*	
	HWR63F-B	HWR63L-B
Connecting flange according EN ISO 9409-1	TK 63	TK 63
Recommended handling weight [kg]	50	50
Pneumatic energy transfer [Quantity]**	6	6
Electrical energy transfer	optional	optional
Self limitation when locking	mechanical	mechanical
Locking stroke [mm]	1	
Repetition accuracy in Z [mm]	0.01	0.01
Repetition accuracy in X, Y [mm]	0.02	0.02
Operating temperature min. [°C]	5	5
Operating temperature max. [°C]	+80	+80
Moment of inertia [kg/cm ²]	3.8	2.6
Weight [kg]	0.45	0.3

*All data measured at 6 bar

**Vacuum possible

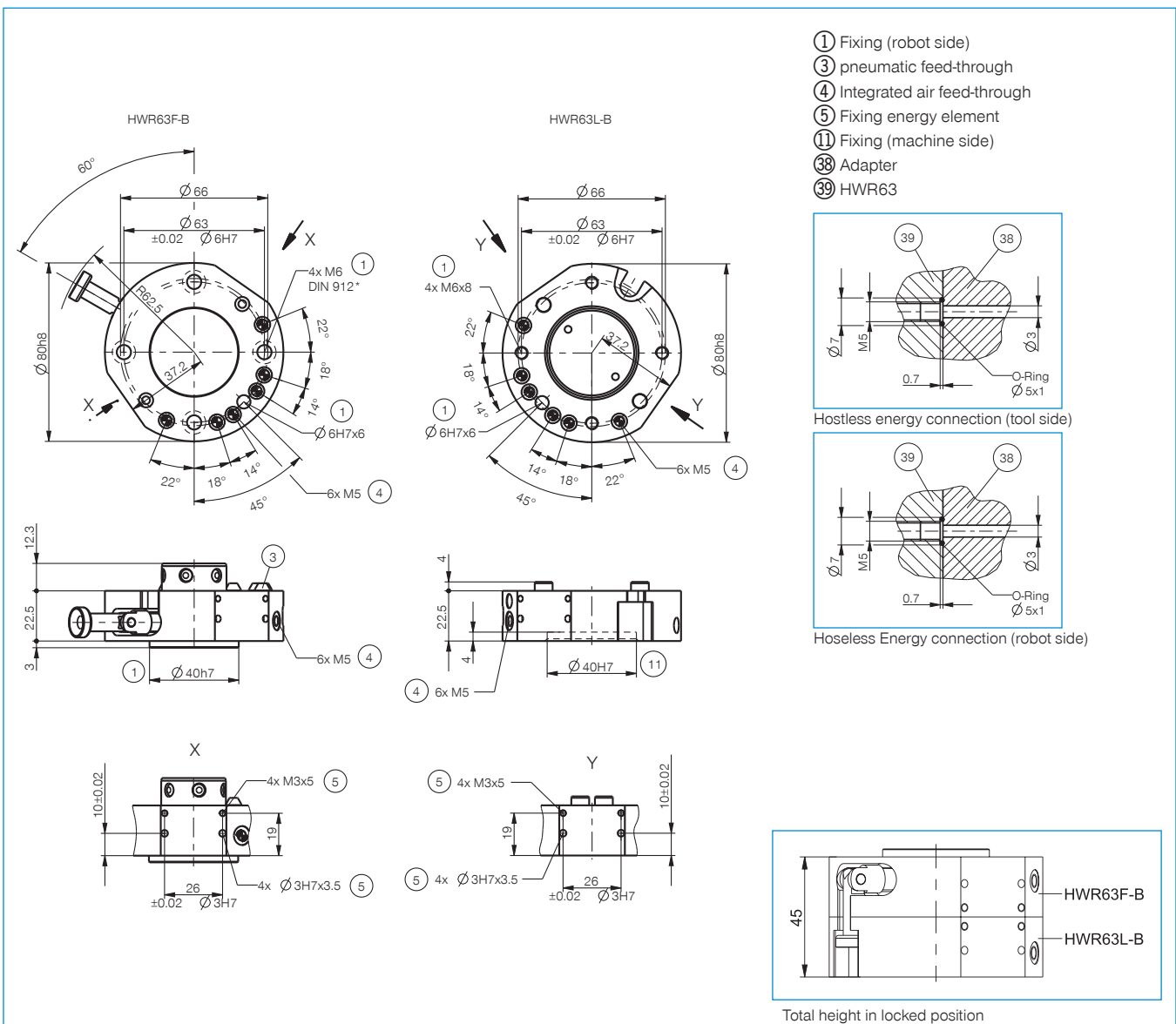

HANDLING COMPONENTS

TOOL CHANGERS - INSTALLATION SIZE HWR80

▶ PRODUCT SPECIFICATIONS



▶ Note

Adapter plate for connection to MCS Modular Construction System optionally available

Energy element for current transmission optionally available

▶ Special features

Allows simple and quick change of application without additional tools

Integrated air T vacuum transfer

▶ Forces and moments

Shows static forces and moments which may impact on the tool changer when locked.

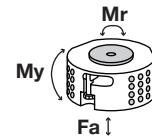

Mr [Nm]	300
My [Nm]	300
Fa [N]	1500

▶ INCLUDED IN DELIVERY



O-Ring

COR0025100

▶ RECOMMENDED ACCESSORIES



Straight Fittings - Quick Connect Style

GVM5



Angled Fittings - Quick Connect Style

WVM5



Energy Elements see page 84

Order no.	► Technical Data*	
	HWR80F-B	HWR80L-B
Connecting flange according EN ISO 9409-1	TK 80	TK 80
Recommended handling weight [kg]	50	50
Pneumatic energy transfer [Quantity]**	6	6
Electrical energy transfer	optional	optional
Self limitation when locking	mechanical	mechanical
Locking stroke [mm]	1	
Repetition accuracy in Z [mm]	0.01	0.01
Repetition accuracy in X, Y [mm]	0.02	0.02
Operating temperature min. [°C]	5	5
Operating temperature max. [°C]	+80	+80
Moment of inertia [kg/cm ²]	3.36	2.8
Weight [kg]	0.66	0.48

*All data measured at 6 bar

**Vacuum possible

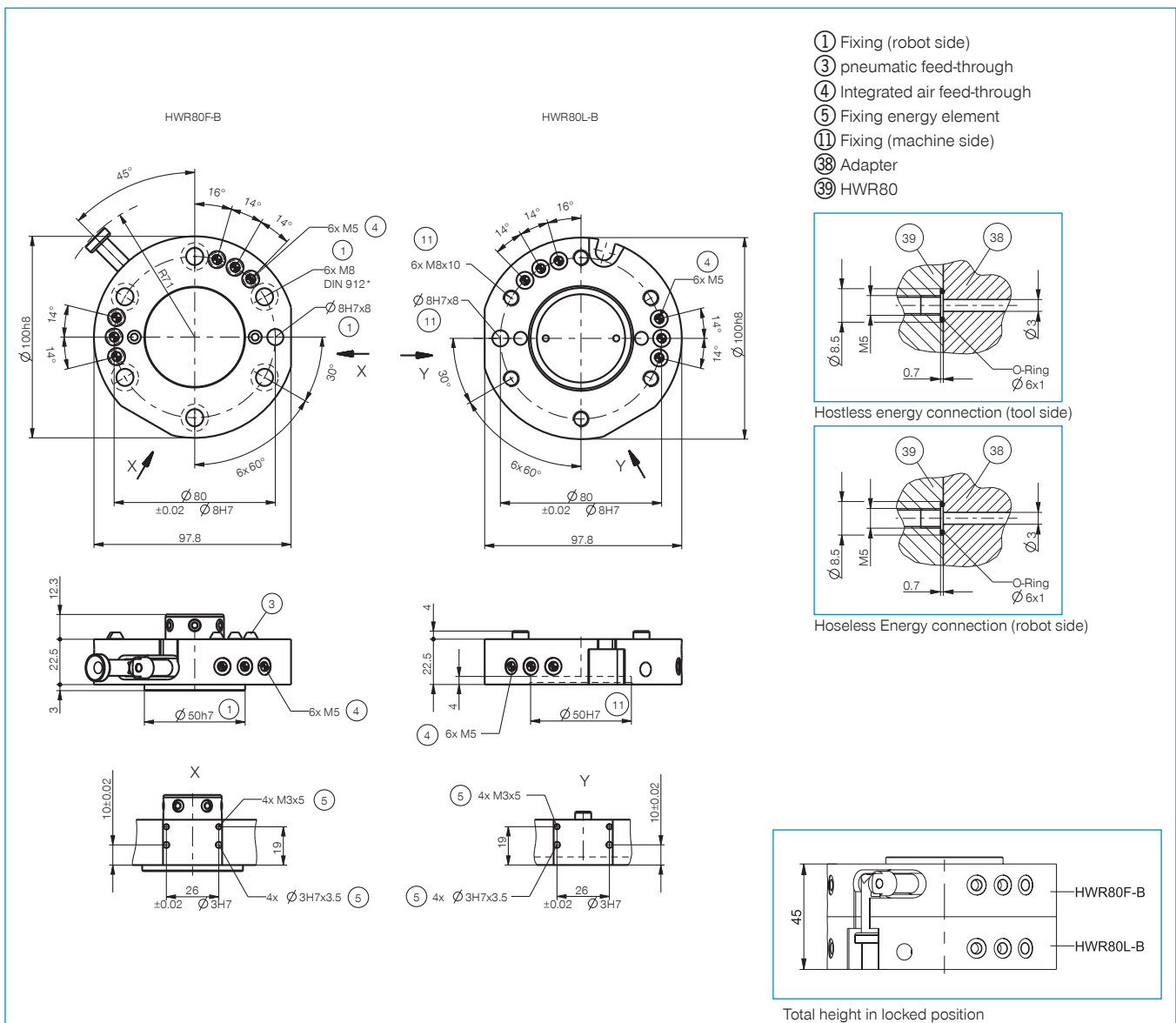

ENERGY ELEMENTS FOR TOOL CHANGER

SERIES HWR

▶ PRODUCT SPECIFICATIONS

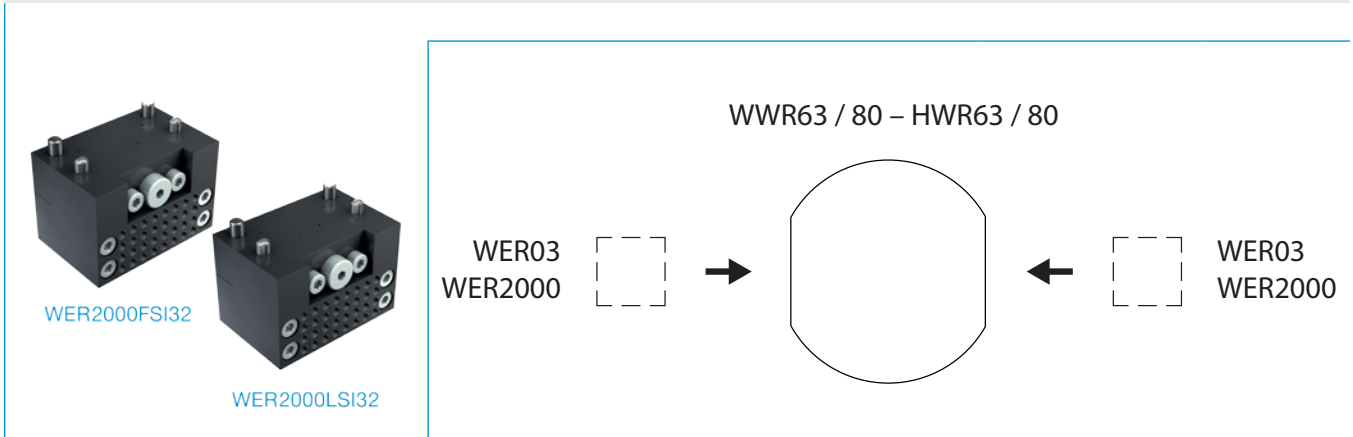

▶ FLUIDIC

▶ Technical Data

Order no.	WER2000FPL06-00	WER2000LPL06-00	WER2000FPL02-06	WER2000LPL02-06	WER2000FPL01-03	WER2000LPL01-03
compatible with	Fix part	Loose part	Fix part	Loose part	Fix part	Loose part
Fixing thread	M5	M5	G1/8"	G1/8"	G1/4"	G1/4"
Number of fluid couplings	6	6	2	2	1	1
Operating pressure [bar]	-0.6 / 10	-0.6 / 10	-0.6 / 10	-0.6 / 10	-0.6 / 10	-0.6 / 10
Weight [kg]	0.05	0.05	0.06	0.07	0.06	0.06

PLUG-IN CONNECTOR FOR ENERGY ELEMENTS SUITABLE FOR WER201 / WER02 / WER03

▶ PLUG-IN CONNECTOR FOR ENERGY ELEMENTS WER201 / WER02 / WER03

Order no.	▶ Technical Data							
	KAG500B4	KAW500B4	B8-G-4	B8-W-4	KAG500S4	KAW500S4	S8-G-4	S8-W-4
Fixing thread	M8	M8	M8	M8	M8	M8	M8	M8
No. of contacts	4	4	4	4	4	4	4	4
Cable length [m]	5	5	-	-	5	5	-	-
Cable-Ø [mm]	4.3	4.3	-	-	4.3	4.7	-	-
Cable sheath material	PUR	PUR	-	-	PUR	PUR	-	-
Bend radius	10xØ	10xØ	-	-	10xØ	10xØ	-	-
Protection to IEC 60529	IP67	IP67	IP67	IP67	IP67	IP67	IP67	IP67
Connection type	Female	Female	Female	Female	Male	Male	Male	Male
Version [Type]	Straight	Angle	Straight	Angle	Straight	Angle	Straight	Angle

HANDLING COMPONENTS

2-JAW PARALLEL GRIPPERS - SERIES GPP1000

▶ PRODUCT ADVANTAGES

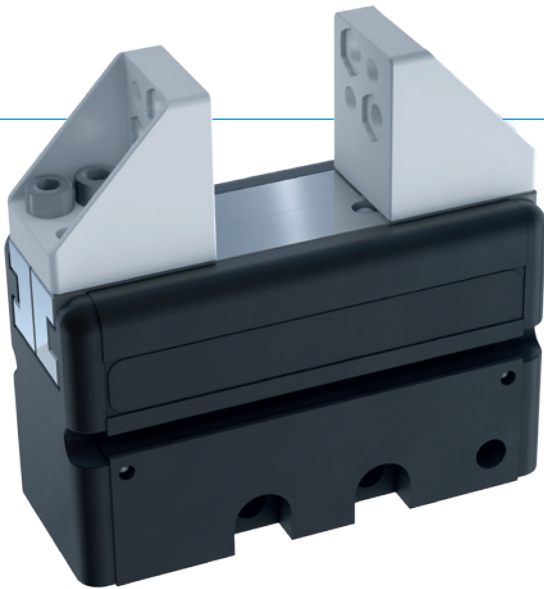

“Cost-effective”

- ▶ Parallel gripper with an unbeatable price/performance ratio
- ▶ Gripper jaw set and fixation material included
- ▶ Can be configured for spring opening or spring closing
- ▶ One installation size, three strokes: 4, 8 and 16 mm per gripper jaw
- ▶ Gripping force of 100 N
- ▶ Service life of up to 2 million cycles

▶ THE BEST PRODUCT FOR YOUR APPLICATION



▶ Our products love the challenge!

Extreme conditions, all over the world—our tried and tested components and systems give you limitless possibilities:

Find the best product for your specific use:

www.zimmer-group.com

► FROM EXTERNAL GRIPPER TO INTERNAL GRIPPER IN 50 SECONDS

DELIVERY STATUS

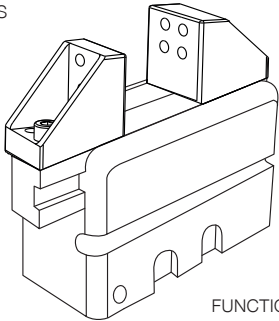

FUNCTION EXTERNAL GRIPPING

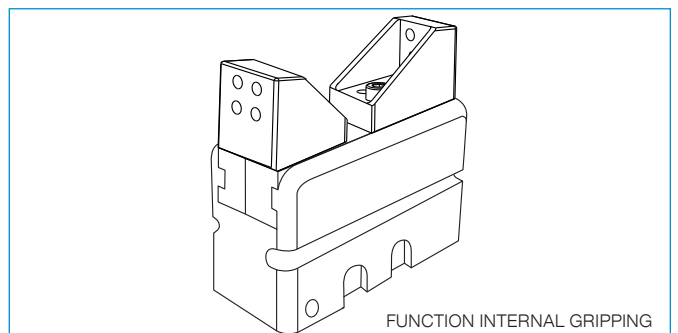
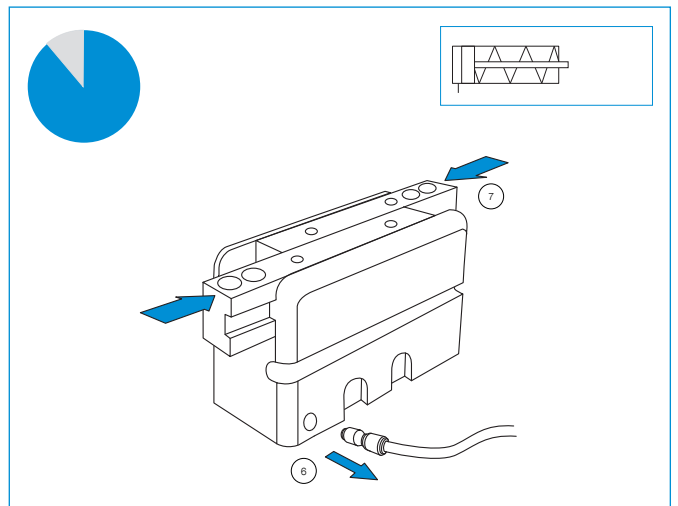
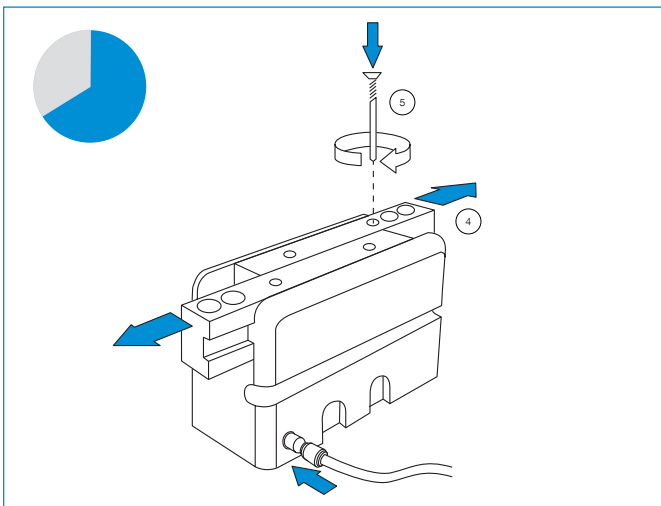
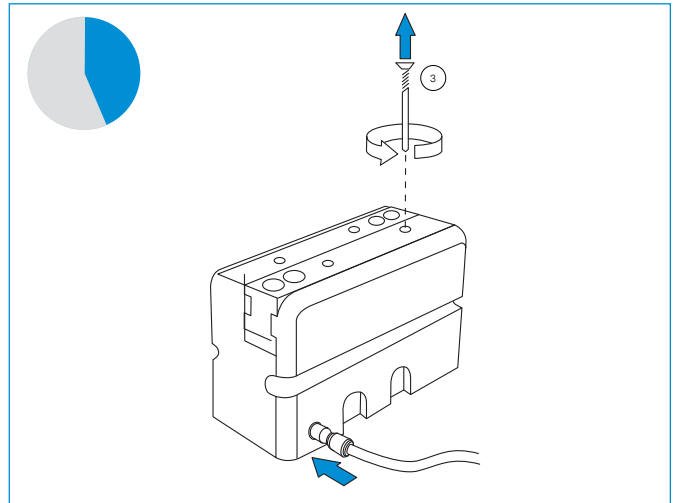
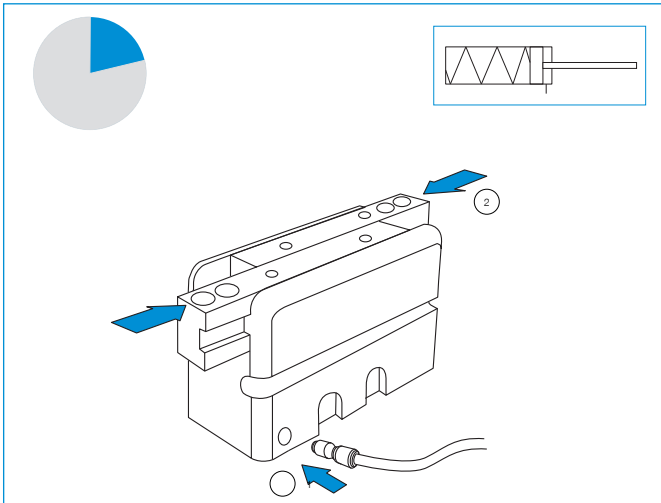

FUNCTION INTERNAL GRIPPING

HANDLING COMPONENTS

2-JAW PARALLEL GRIPPERS - INSTALLATION SIZE GPP1104

▶ PRODUCT SPECIFICATIONS



▶ Gripping force diagram

Shows the arithmetic total of the individual forces that occur on the gripper fingers, depending on the gripper finger length

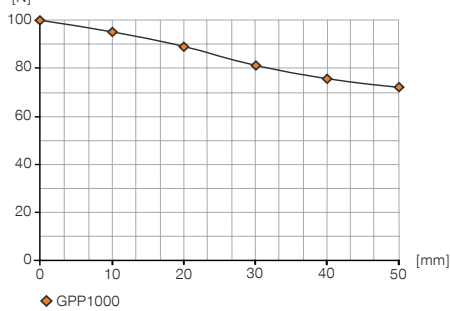

▶ Forces and moments

Displays static forces and moments that can also have an effect, besides the gripping force.

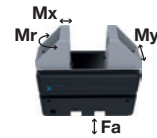

Steel top jaws Plastic top jaws

Mr [Nm]	4	1
Mx [Nm]	4	2
My [Nm]	2	1
Fa [N]	400	100

▶ INCLUDED IN DELIVERY

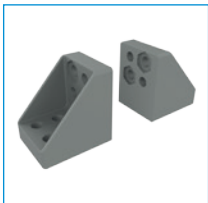

Plastic top jaws and assembly material

ZUB1100

▶ RECOMMENDED ACCESSORIES, SEE PAGE 94

Order no.	▶ Technical Data*
Stroke per jaw [mm]	4
Grip force in grip direction min. [N]	100
Travel time in gripping direction [ms]	20
Reset time using spring [ms]	30
Weight per jaw max. [kg]	0.10
Repetition accuracy +/- [mm]	0.05
Operating pressure [bar]	2 ... 6
Operating temperature [°C]	5 ... +60
Air volume per cycle [cm ³]	1.4
Protection to IEC 60529	IP30
Weight [kg]	0.16

*All data measured at 6 bar

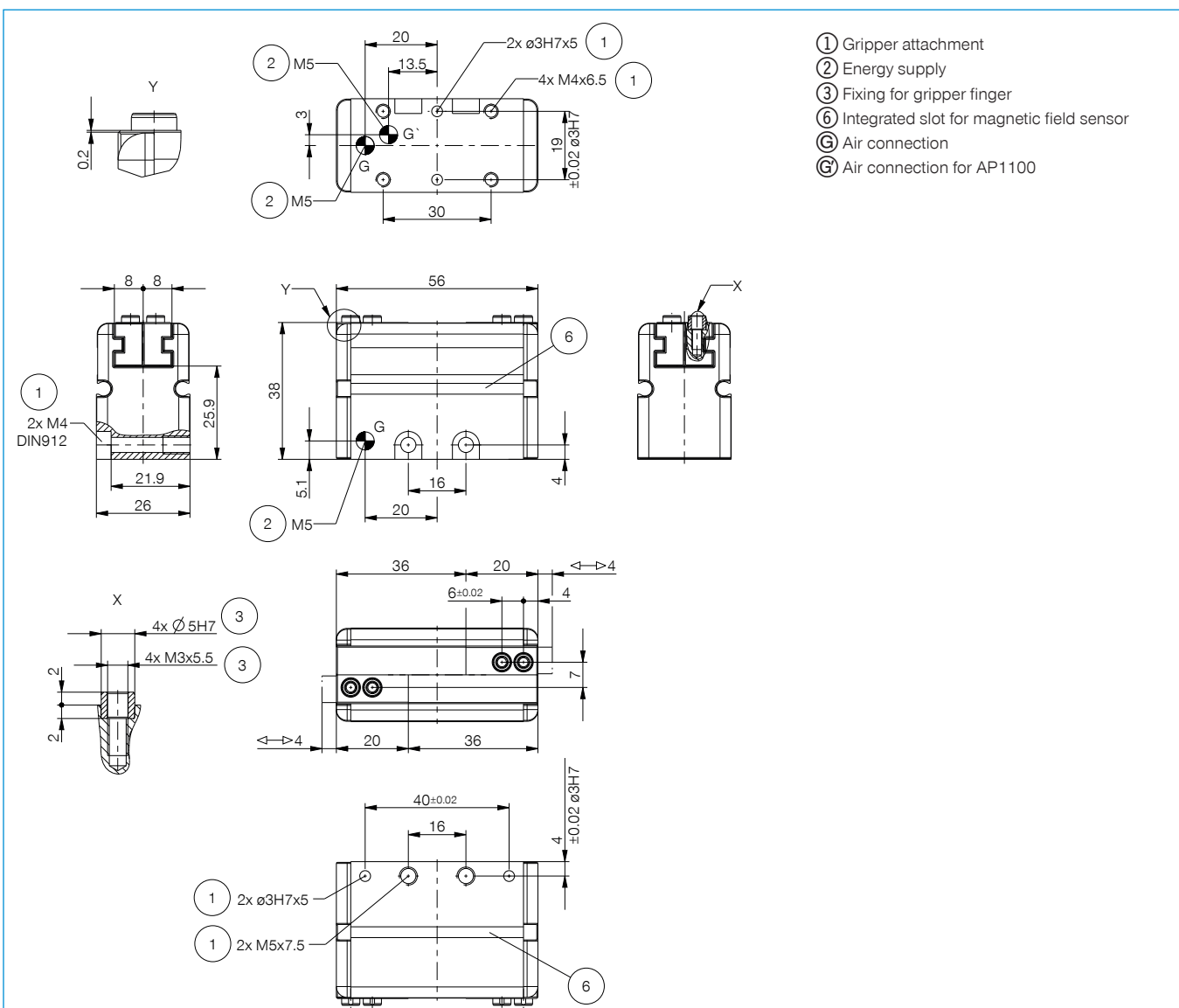

HANDLING COMPONENTS

2-JAW PARALLEL GRIPPERS - INSTALLATION SIZE GPP1108

▶ PRODUCT SPECIFICATIONS



▶ Gripping force diagram

Shows the arithmetic total of the individual forces that occur on the gripper fingers, depending on the gripper finger length

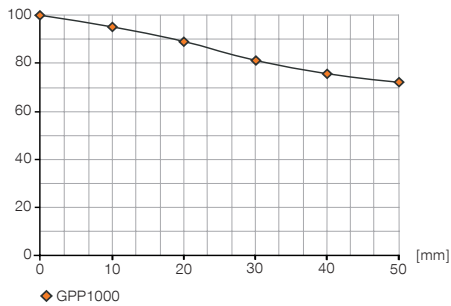

▶ Forces and moments

Displays static forces and moments that can also have an effect, besides the gripping force.

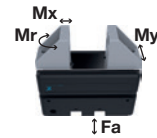

Steel top jaws Plastic top jaws

Mr [Nm]	4	1
Mx [Nm]	4	2
My [Nm]	2	1
Fa [N]	400	100

▶ INCLUDED IN DELIVERY

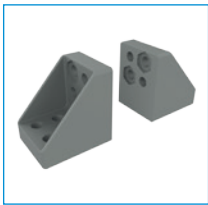

Plastic top jaws and assembly material

ZUB1100

▶ RECOMMENDED ACCESSORIES, SEE PAGE 94

Order no.	▶ Technical Data*
Stroke per jaw [mm]	8
Grip force in grip direction min. [N]	100
Travel time in gripping direction [ms]	25
Reset time using spring [ms]	40
Weight per jaw max. [kg]	0.10
Repetition accuracy +/- [mm]	0.05
Operating pressure [bar]	2 ... 6
Operating temperature [°C]	5 ... +60
Air volume per cycle [cm³]	2.7
Protection to IEC 60529	IP30
Weight [kg]	0.17

*All data measured at 6 bar

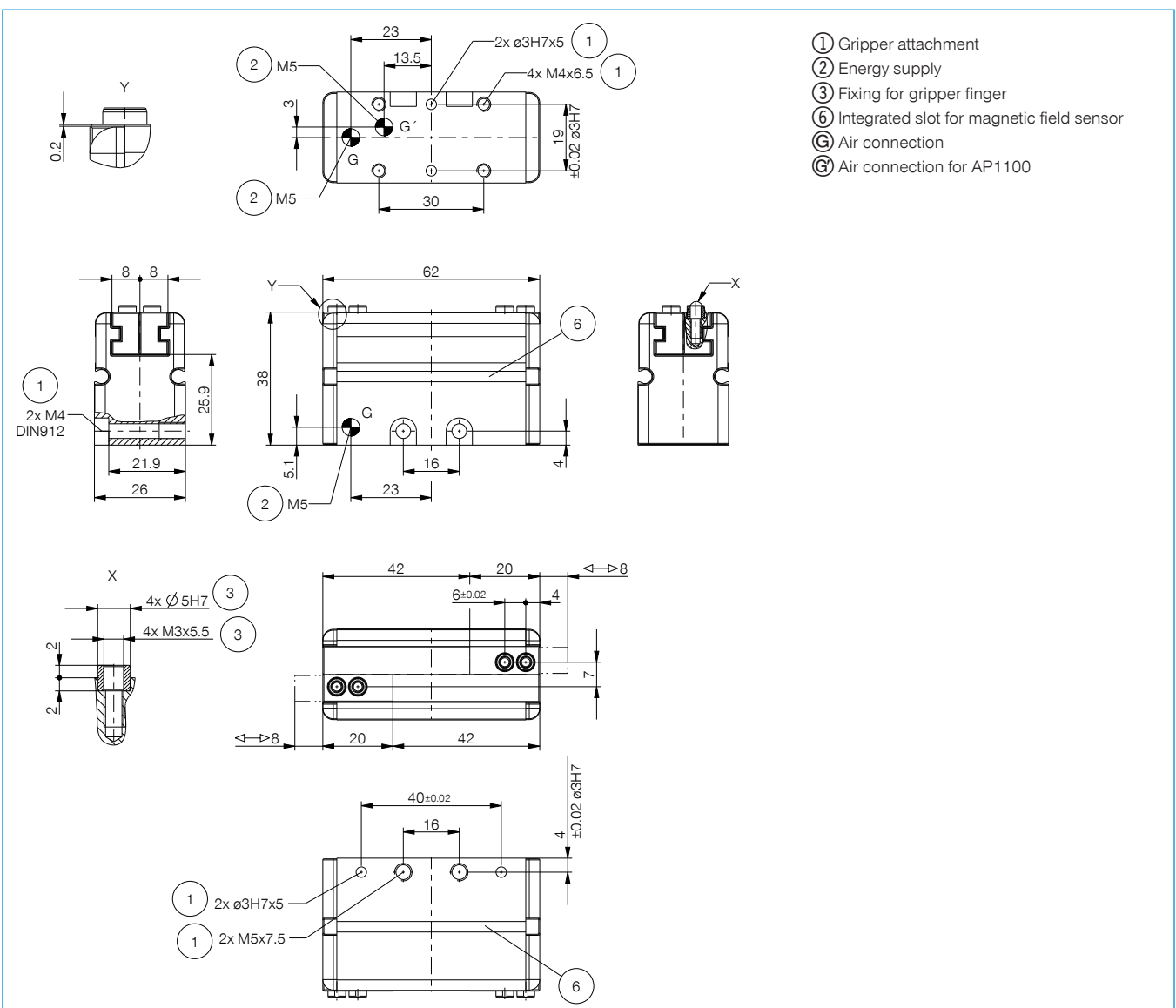

- ① Gripper attachment
- ② Energy supply
- ③ Fixing for gripper finger
- ⑥ Integrated slot for magnetic field sensor
- G Air connection
- G' Air connection for AP1100

HANDLING COMPONENTS

2-JAW PARALLEL GRIPPERS - INSTALLATION SIZE GPP1116

▶ PRODUCT SPECIFICATIONS



▶ Gripping force diagram

Shows the arithmetic total of the individual forces that occur on the gripper fingers, depending on the gripper finger length

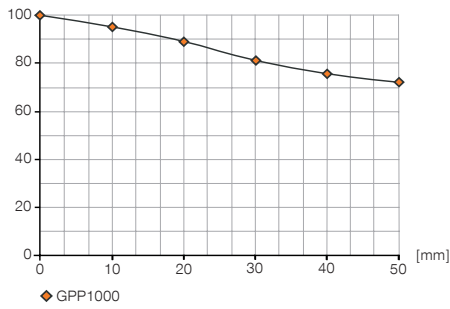

▶ Forces and moments

Displays static forces and moments that can also have an effect, besides the gripping force.



Steel top jaws Plastic top jaws

Mr [Nm]	4	1
Mx [Nm]	4	2
My [Nm]	2	1
Fa [N]	400	100

▶ INCLUDED IN DELIVERY

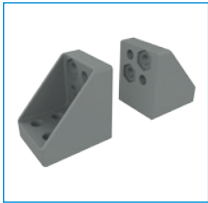

Plastic top jaws and assembly material

ZUB1100

▶ RECOMMENDED ACCESSORIES, SEE PAGE 94

Order no.	▶ Technical Data*
Stroke per jaw [mm]	16
Grip force in grip direction min. [N]	100
Travel time in gripping direction [ms]	30
Reset time using spring [ms]	100
Weight per jaw max. [kg]	0.10
Repetition accuracy +/- [mm]	0.05
Operating pressure [bar]	2 ... 6
Operating temperature [°C]	5 ... +60
Air volume per cycle [cm ³]	5.6
Protection to IEC 60529	IP30
Weight [kg]	0.20

*All data measured at 6 bar

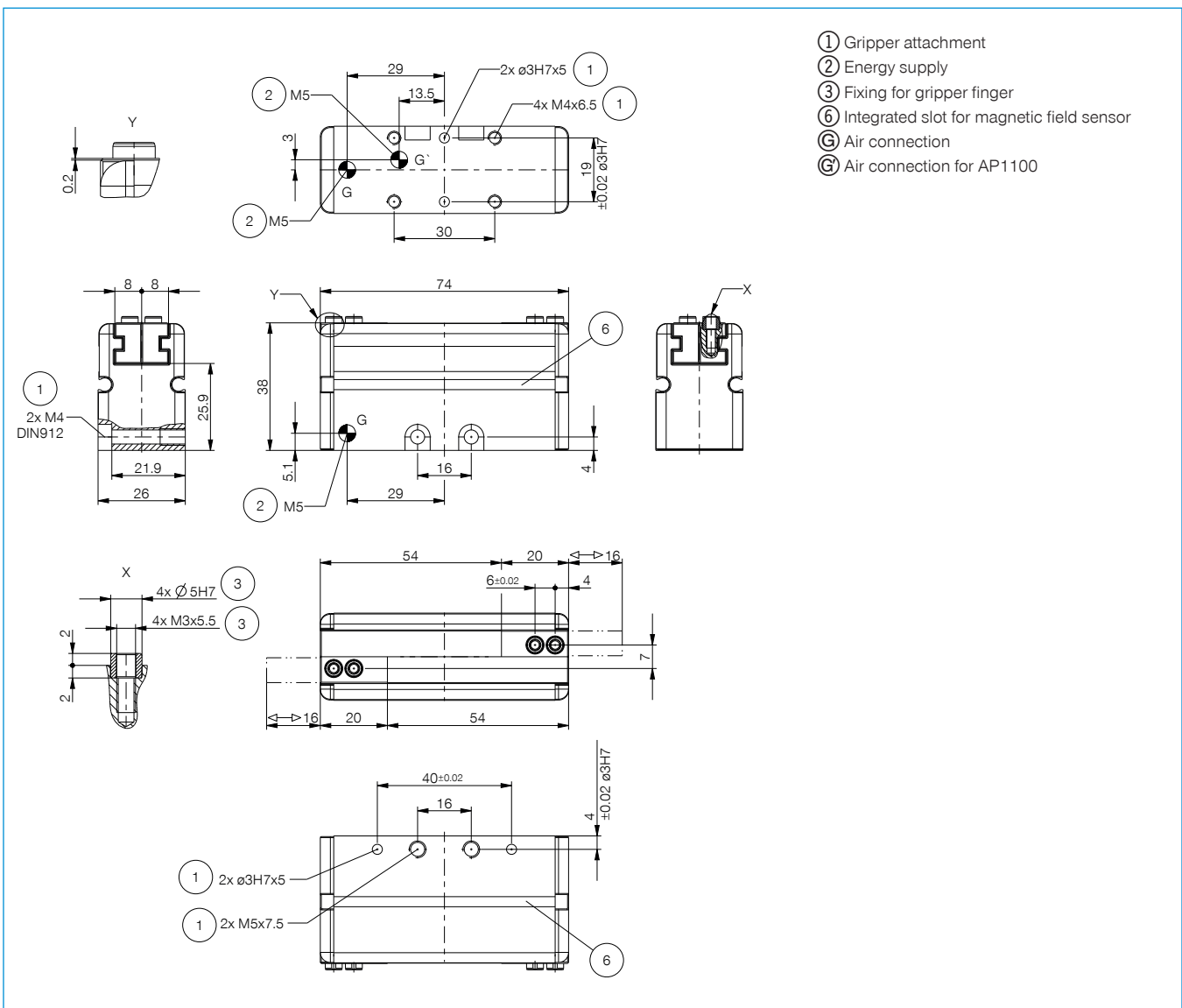

HANDLING COMPONENTS

2-JAW PARALLEL GRIPPERS - SERIES GPP1000

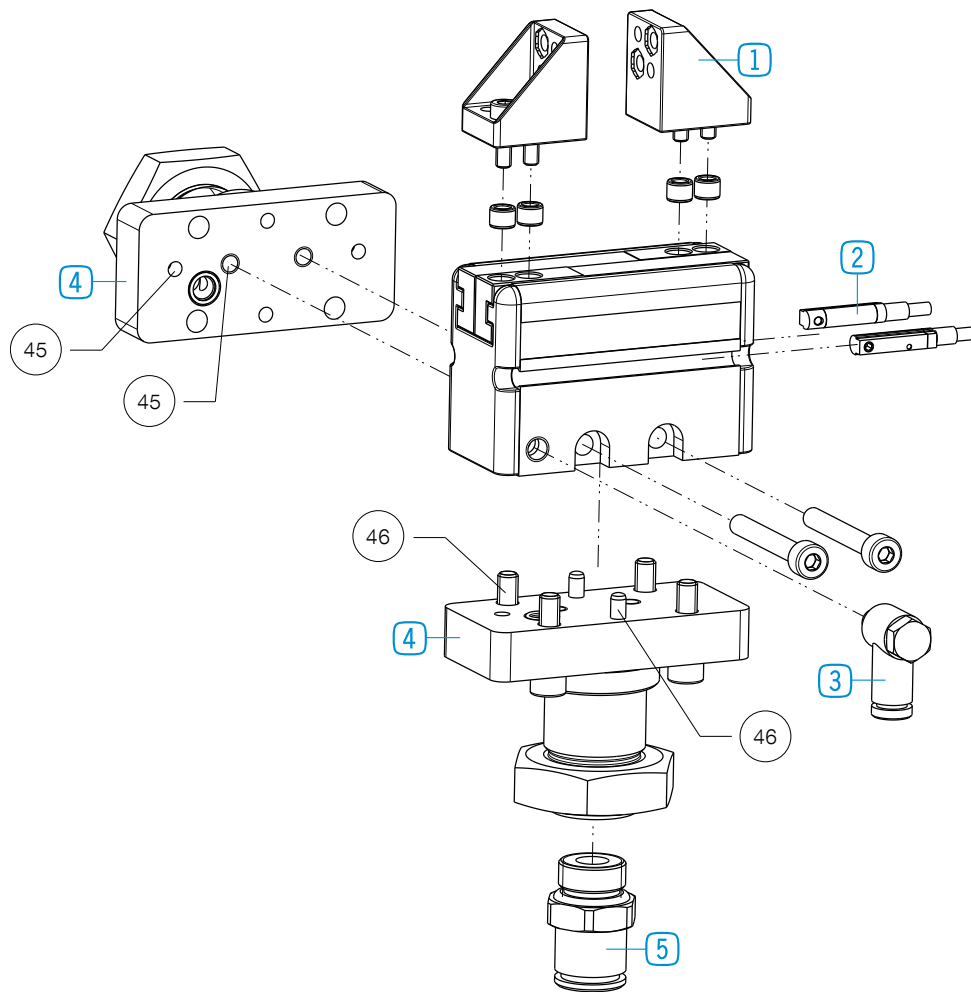

► INCLUDED IN DELIVERY



1
Plastic top jaws and
assembly material
ZUB1100

▶ RECOMMENDED ACCESSORIES



PNP Magnetic field sensor Straight
Cable 0,3 m - Connector M8
MFS1000SKHR



NPN Magnetic field sensor Straight
Cable 0,3 m - Connector M8
MFS1000SKHR-NPN



Straight Fittings - Quick
Connect Style
GVM5



Angled Fittings - Quick
Connect Style
WVM5



MCS Adapter plate
AP1100



Straight Fittings - Quick
Connect Style
GV1-4X6



Angled Fittings - Quick
Connect Style
WV1-4X6

▶ TECHNICAL DRAWINGS ACCESSORIES

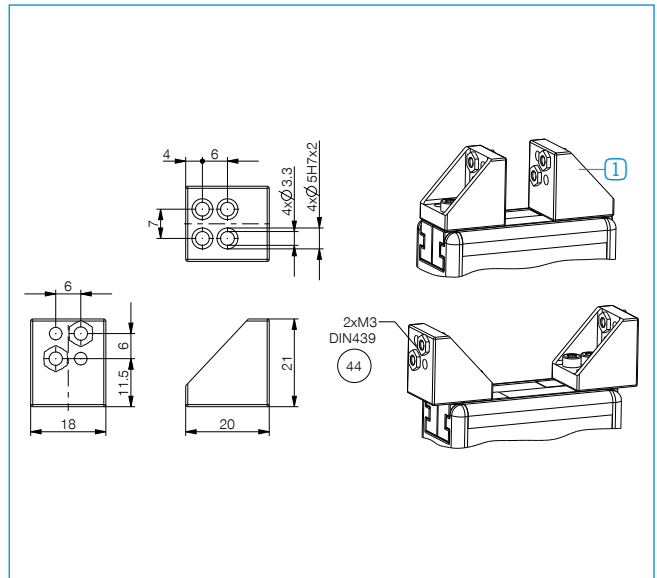
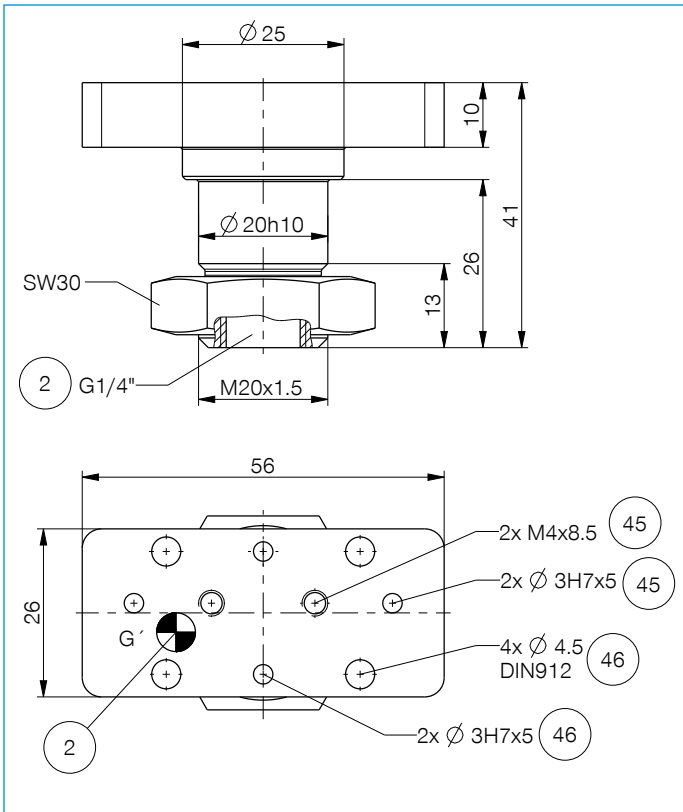

- ② Energy supply
- ④④ Fixing for gripper finger
- ④⑤ Horizontal mounting
- ④⑥ Vertical mounting
- ⓐ Gripper air connection

HANDLING COMPONENTS

2-JAW ANGULAR GRIPPERS - INSTALLATION SIZE GZ1020

▶ PRODUCT SPECIFICATIONS



▶ Gripping force diagram

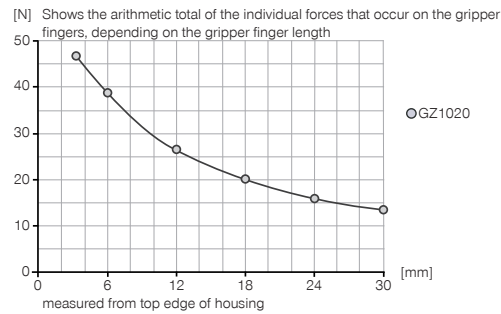

▶ Forces and moments

Displays static forces and moments that can also have an effect, besides the gripping force.

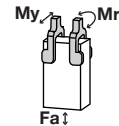

Mr [Nm]	1
My [Nm]	0.6
Fa [N]	60

▶ INCLUDED IN DELIVERY

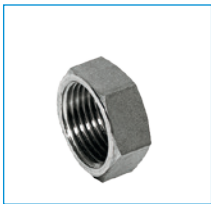

Locking nut

C093610009

▶ RECOMMENDED ACCESSORIES



Straight Fittings - Quick Connect Style

GVM5



Plug-in connector Straight Cable 5m - Socket M8 (female)

KAG500



Plug-in connector customizable Straight - Connector M8

S8-G-3



Plug-in connector customizable Straight - Connector M12

S12-G-3

Order no.	▶ Technical Data*		
	GZ1020-01	GZ1020-02	GZ1020-03
Stroke per jaw [°]	8	8	8
Gripping force in closing [N]	62	62	62
Closing moment [Nm]	0.5	0.5	0.5
Closing time [s]	0.01	0.01	0.01
Opening time [s]	0.02	0.02	0.02
Operating pressure min. [bar]	2	2	2
Operating pressure max. [bar]	6	6	6
Operating temperature min. [°C]	5	5	5
Operating temperature max. [°C]	+80	+80	+80
Air volume per cycle [cm ³]	0.25	0.25	0.25
Gripper finger with integrated sensor	No	Yes	No
Weight [kg]	0.017	0.03	0.015

*All data measured at 6 bar

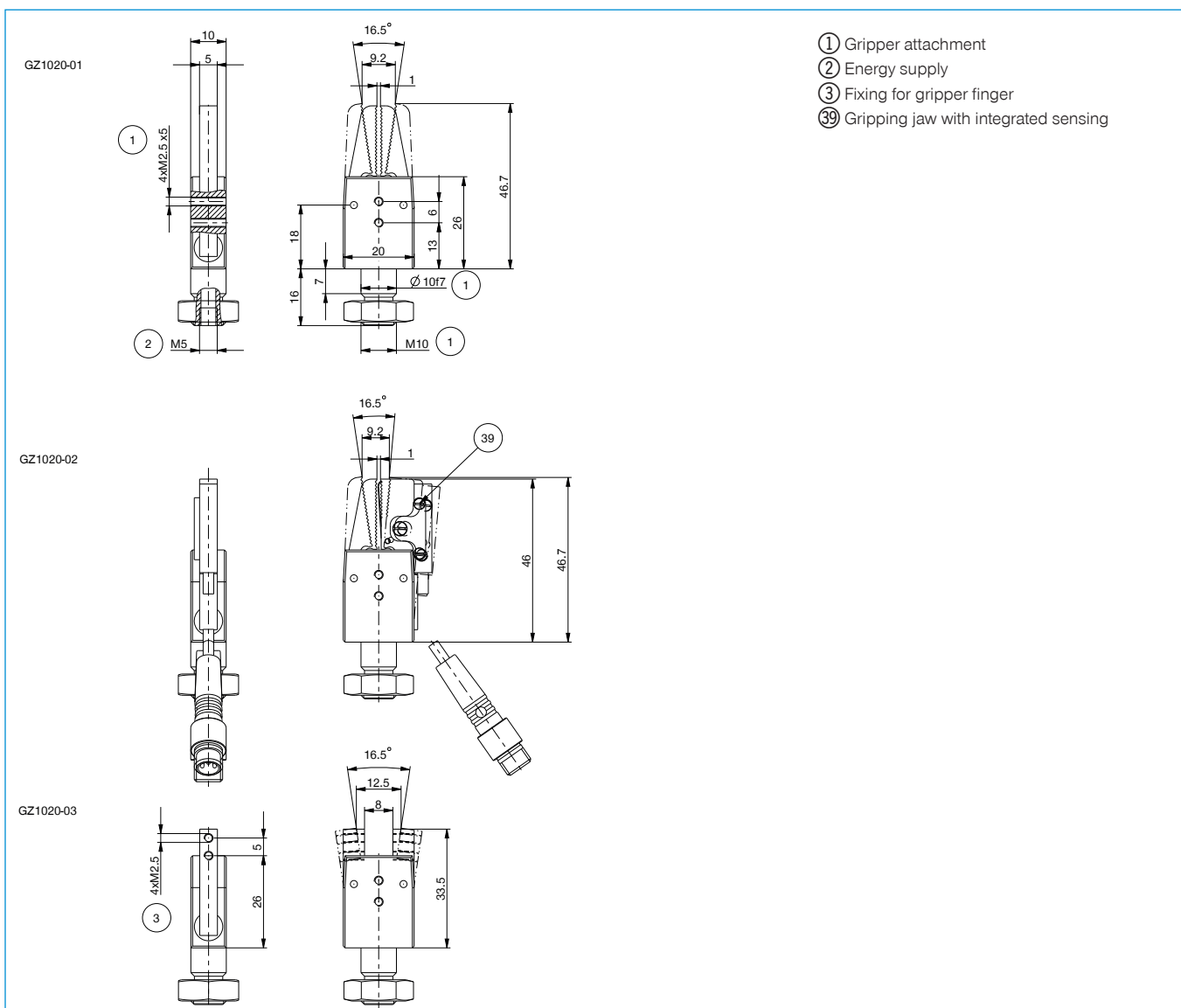

HANDLING COMPONENTS

2-JAW ANGULAR GRIPPERS - INSTALLATION SIZE GZ1030

▶ PRODUCT SPECIFICATIONS



▶ Gripping force diagram

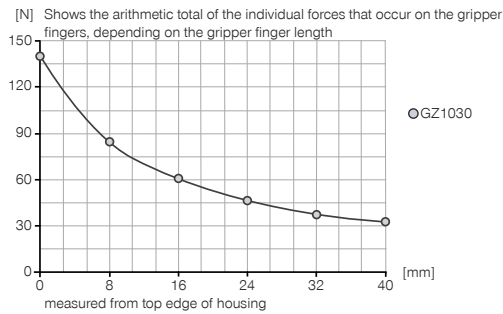

▶ Forces and moments

Displays static forces and moments that can also have an effect, besides the gripping force.

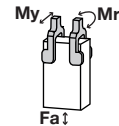

Mr [Nm]	1.5
My [Nm]	1
Fa [N]	110

▶ INCLUDED IN DELIVERY



Locking nut

C093614159

▶ RECOMMENDED ACCESSORIES



Straight Fittings - Quick Connect Style

GVM5



Plug-in connector Straight Cable 5m - Socket M8 (female)

KAG500



Plug-in connector customizable Straight - Connector M8

S8-G-3



Plug-in connector customizable Straight - Connector M12

S12-G-3

Order no.	▶ Technical Data*		
	GZ1030-01	GZ1030-02	GZ1030-03
Stroke per jaw [°]	11	11	11
Gripping force in closing [N]	130	130	130
Closing moment [Nm]	1.6	1.6	1.6
Closing time [s]	0.02	0.02	0.02
Opening time [s]	0.03	0.03	0.03
Operating pressure min. [bar]	2	2	2
Operating pressure max. [bar]	6	6	6
Operating temperature min. [°C]	5	5	5
Operating temperature max. [°C]	+80	+80	+80
Air volume per cycle [cm ³]	0.9	0.9	0.9
Gripper finger with integrated sensor	No	Yes	No
Weight [kg]	0.05	0.063	0.046

*All data measured at 6 bar

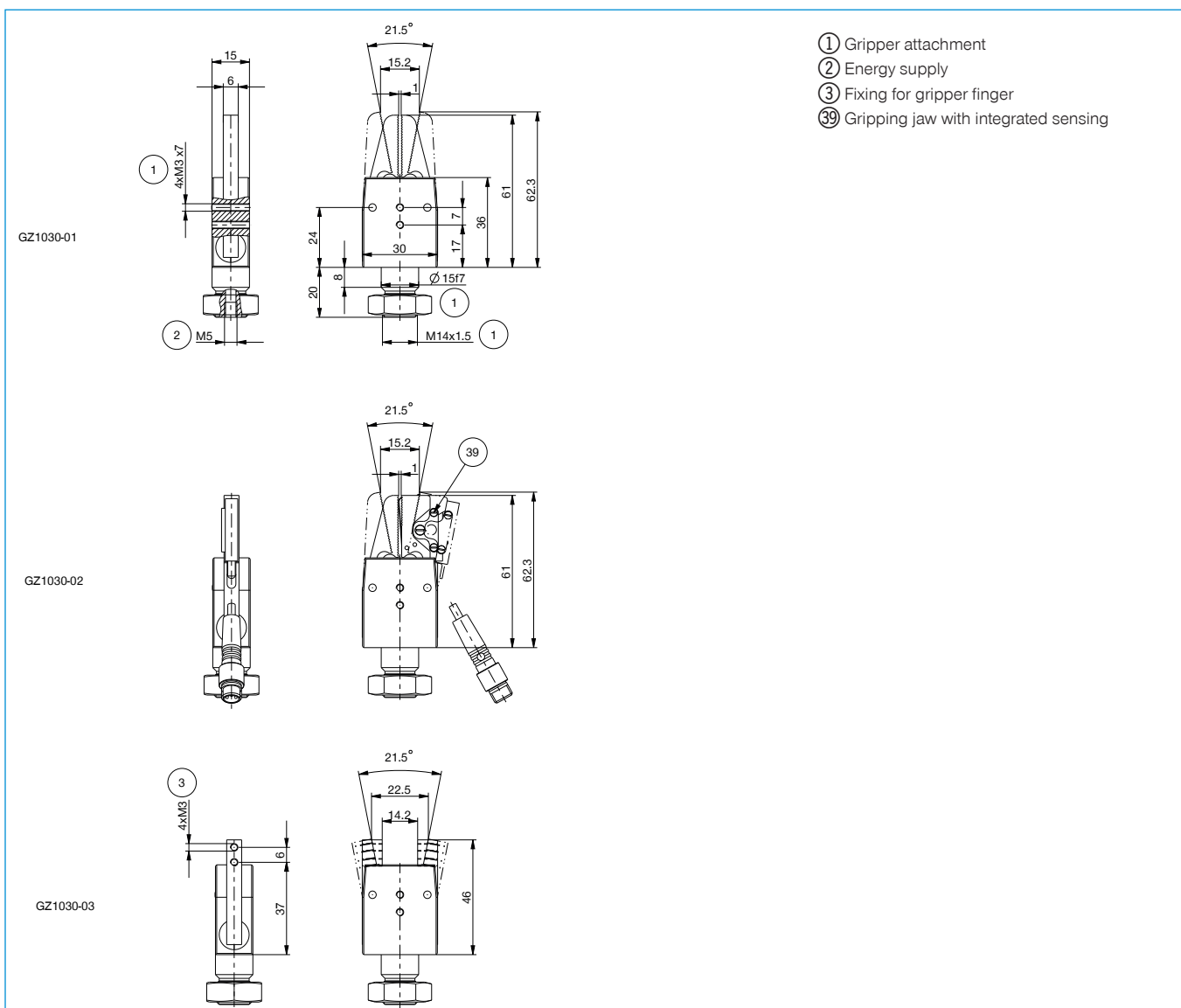

HANDLING COMPONENTS

2-JAW ANGULAR GRIPPERS - INSTALLATION SIZE GZ1040

▶ PRODUCT SPECIFICATIONS



▶ Gripping force diagram

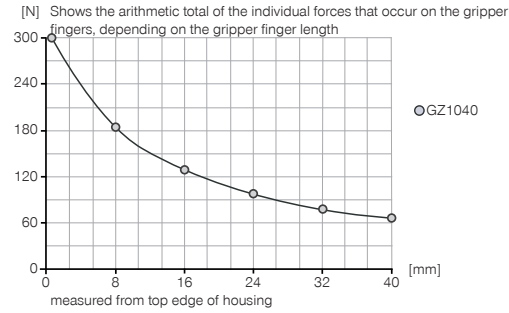

▶ Forces and moments

Displays static forces and moments that can also have an effect, besides the gripping force.

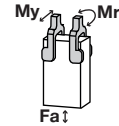

Mr [Nm]	2.5
My [Nm]	2
Fa [N]	200

▶ INCLUDED IN DELIVERY



Locking nut

C093620159

▶ RECOMMENDED ACCESSORIES



Straight Fittings - Quick Connect Style

GV1-8X6



Plug-in connector Straight Cable 5m - Socket M8 (female)

KAG500



Plug-in connector customizable Straight - Connector M8

S8-G-3



Plug-in connector customizable Straight - Connector M12

S12-G-3

Order no.	▶ Technical Data*		
	GZ1040-01	GZ1040-02	GZ1040-03
Stroke per jaw [°]	10	10	10
Gripping force in closing [N]	315	315	315
Closing moment [Nm]	4.4	4.4	4.4
Closing time [s]	0.02	0.02	0.02
Opening time [s]	0.04	0.04	0.04
Operating pressure min. [bar]	2	2	2
Operating pressure max. [bar]	6	6	6
Operating temperature min. [°C]	5	5	5
Operating temperature max. [°C]	+80	+80	+80
Air volume per cycle [cm ³]	2	2	2
Gripper finger with integrated sensor	No	Yes	No
Weight [kg]	0.11	0.125	0.105

*All data measured at 6 bar

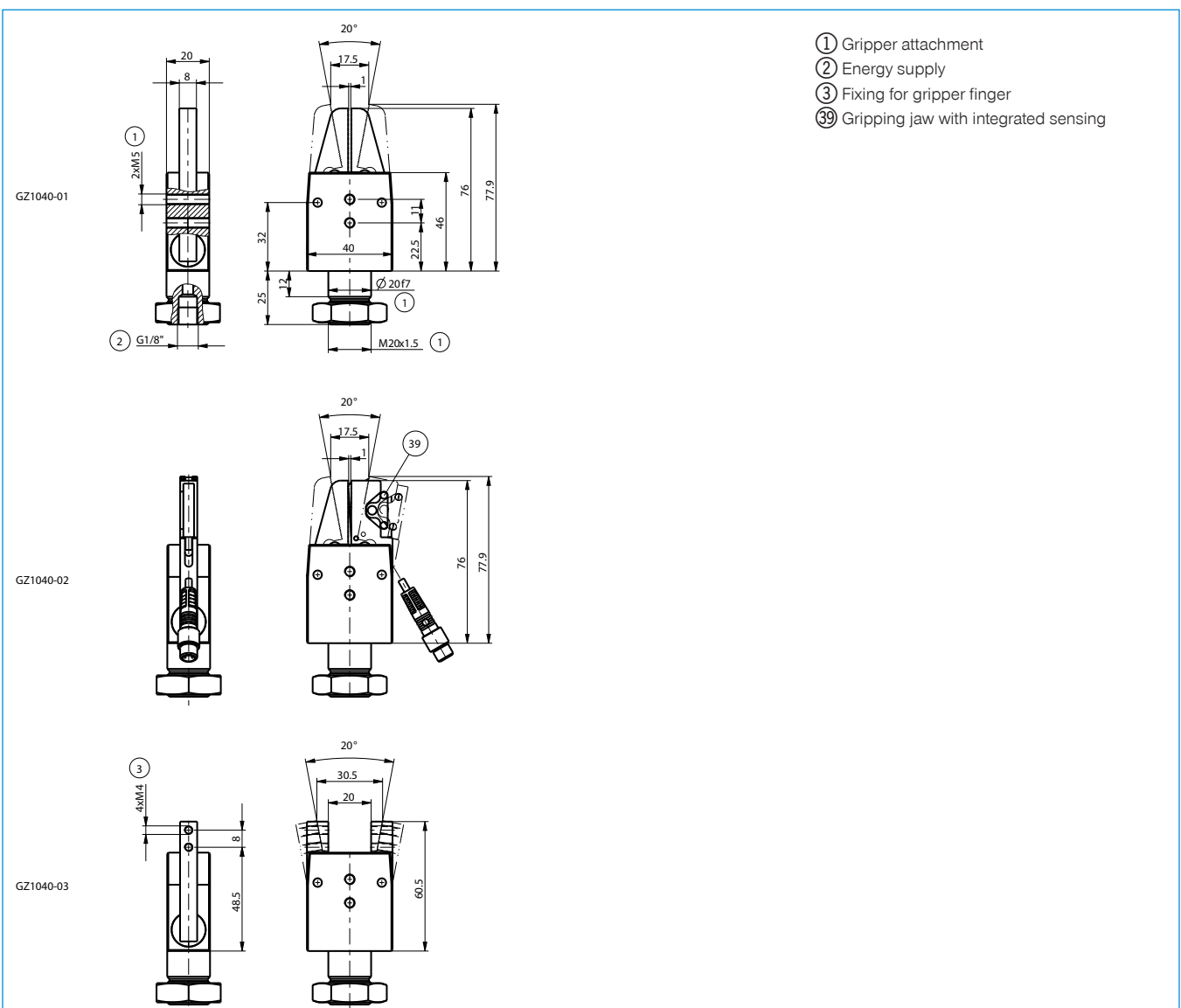

HANDLING COMPONENTS

CUTTING TONGS - INSTALLATION SIZE ZK1030

▶ PRODUCT SPECIFICATIONS



▶ INCLUDED IN DELIVERY

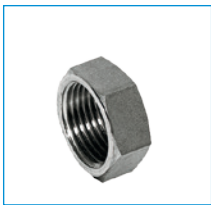

Locking nut

C093610009

▶ RECOMMENDED ACCESSORIES



Angled Fittings - Barb Style Connection

WVM3



Straight Fittings - Barb Style Connection

GVM3



Sensor holder

KHD30



Magnetic field sensor
Straight Cable 0,3 m -
Connector M8

MFS204SKHC



Magnetic field sensor
Straight Cable 5 m

MFS204KHC



Cutting inserts, see
page 110

► Technical Data*	
Order no.	ZK1030
Stroke per jaw [°]	4.25
Gripping moment in closing [Nm]	14
Closing time [s]	0.01
Opening time [s]	0.1
Operating pressure min. [bar]	2
Operating pressure max. [bar]	6
Operating temperature min. [°C]	5
Operating temperature max. [°C]	+80
Air volume per cycle [cm ³]	5
Weight [kg]	0.08

Possible cutting diameters	
possible cut-Ø max. plastics [mm]	2
possible cut-Ø max. hard-plastic [mm]	
possible cut-Ø max. copper [mm]	1
possible cut-Ø max. steel [mm]	0.5
possible cut-Ø max. piano wire [mm]	0.3

*All data measured at 6 bar

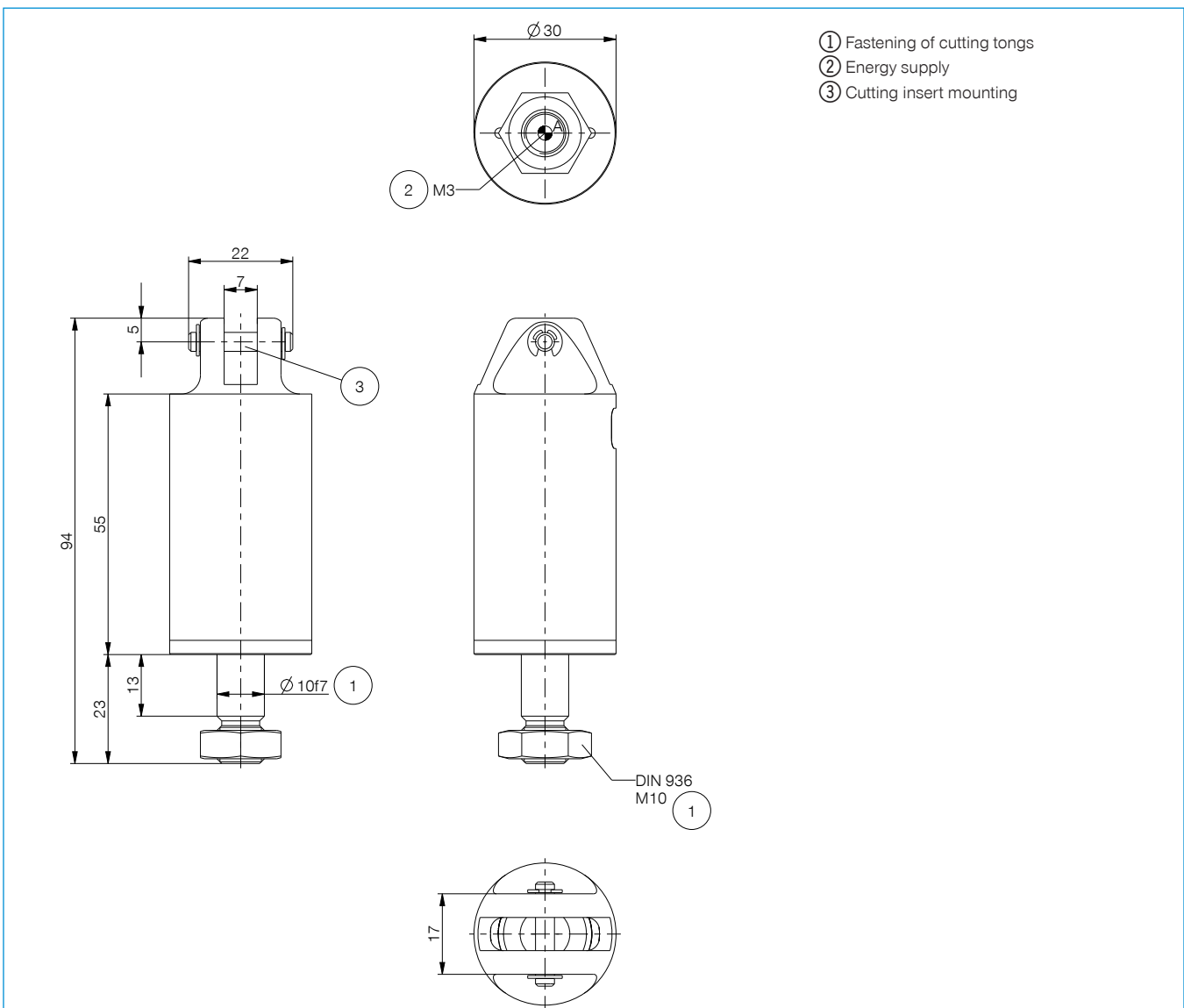

HANDLING COMPONENTS

CUTTING TONGS - INSTALLATION SIZE ZK1036

▶ PRODUCT SPECIFICATIONS



▶ INCLUDED IN DELIVERY

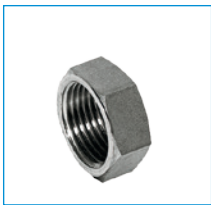

Locking nut

C093614159

▶ RECOMMENDED ACCESSORIES



Angled Fittings - Quick Connect Style

WVM5



Straight Fittings - Quick Connect Style

GVM5



Sensor holder

KHD36



Magnetic field sensor
Straight Cable 0,3 m -
Connector M8
MFS204SKHC



Magnetic field sensor
Straight Cable 5 m

MFS204KHC



Cutting inserts, see
page 110

► Technical Data*	
Order no.	ZK1036
Stroke per jaw [°]	5
Gripping moment in closing [Nm]	40
Closing time [s]	0.04
Opening time [s]	0.15
Operating pressure min. [bar]	2
Operating pressure max. [bar]	6
Operating temperature min. [°C]	5
Operating temperature max. [°C]	+80
Air volume per cycle [cm ³]	9.2
Weight [kg]	0.13

Possible cutting diameters	
possible cut-Ø max. plastics [mm]	4
possible cut-Ø max. hard-plastic [mm]	2.6
possible cut-Ø max. copper [mm]	1.6
possible cut-Ø max. steel [mm]	1
possible cut-Ø max. piano wire [mm]	0.5

*All data measured at 6 bar

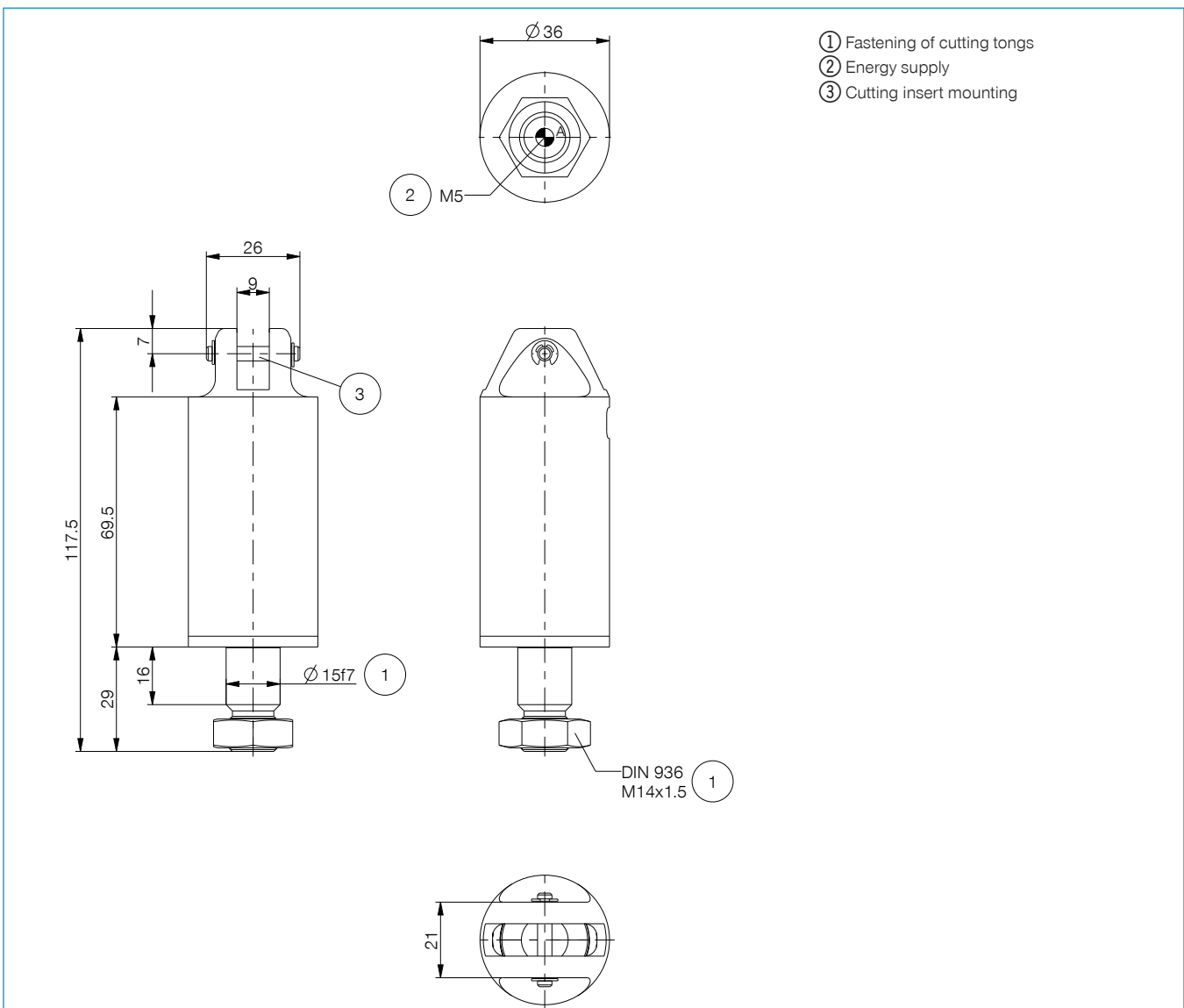

HANDLING COMPONENTS

CUTTING TONGS - INSTALLATION SIZE ZK1045

▶ PRODUCT SPECIFICATIONS



▶ INCLUDED IN DELIVERY



Locking nut

C093620159

▶ RECOMMENDED ACCESSORIES



Angled Fittings - Quick Connect Style

WV1-8X6



Straight Fittings - Quick Connect Style

GV1-8X6



Sensor holder

KHD45



Magnetic field sensor
Straight Cable 0,3 m -
Connector M8

MFS204SKHC



Magnetic field sensor
Straight Cable 5 m

MFS204KHC



Cutting inserts, see
page 110

► Technical Data*	
Order no.	ZK1045
Stroke per jaw [°]	8.5
Gripping moment in closing [Nm]	98
Closing time [s]	0.06
Opening time [s]	0.2
Operating pressure min. [bar]	2
Operating pressure max. [bar]	6
Operating temperature min. [°C]	5
Operating temperature max. [°C]	+80
Air volume per cycle [cm³]	32
Weight [kg]	0.24

Possible cutting diameters	
possible cut-Ø max. plastics [mm]	7
possible cut-Ø max. hard-plastic [mm]	5
possible cut-Ø max. copper [mm]	2.6
possible cut-Ø max. steel [mm]	2
possible cut-Ø max. piano wire [mm]	1

*All data measured at 6 bar

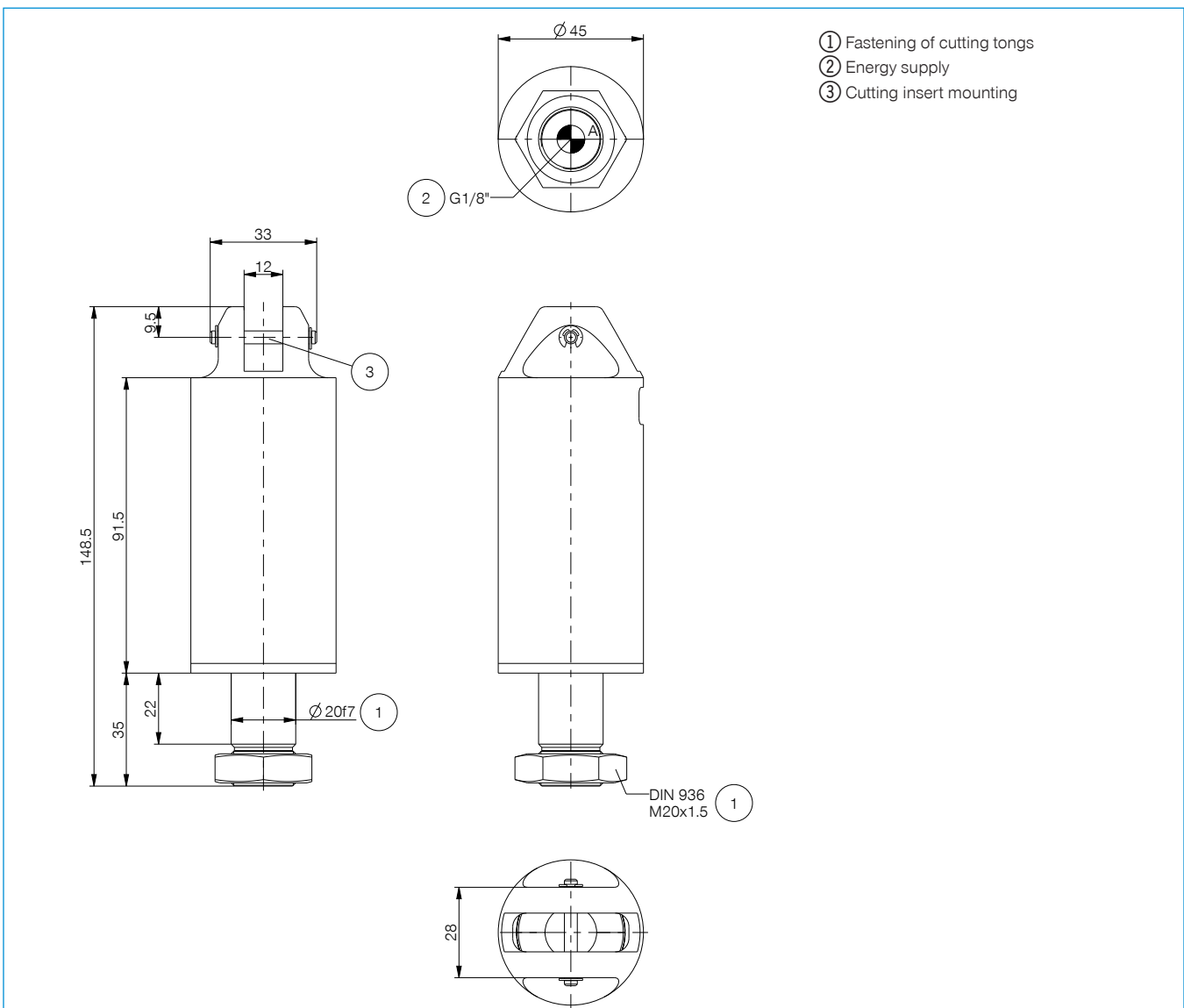

HANDLING COMPONENTS

CUTTING TONGS - INSTALLATION SIZE ZK1065

▶ PRODUCT SPECIFICATIONS



▶ INCLUDED IN DELIVERY



Locking nut

C093620159

▶ RECOMMENDED ACCESSORIES



Angled Fittings - Quick Connect Style

WV1-8X6



Straight Fittings - Quick Connect Style

GV1-8X6



Sensor holder

KHD65



Magnetic field sensor
Straight Cable 0,3 m -
Connector M8

MFS204SKHC



Magnetic field sensor
Straight Cable 5 m

MFS204KHC



Cutting inserts, see
page 110

► Technical Data*	
Order no.	ZK1065
Stroke per jaw [°]	13
Gripping moment in closing [Nm]	400
Closing time [s]	0.1
Opening time [s]	0.4
Operating pressure min. [bar]	2
Operating pressure max. [bar]	6
Operating temperature min. [°C]	5
Operating temperature max. [°C]	+80
Air volume per cycle [cm ³]	130
Weight [kg]	0.67

Possible cutting diameters	
possible cut-Ø max. plastics [mm]	11
possible cut-Ø max. hard-plastic [mm]	8
possible cut-Ø max. copper [mm]	6
possible cut-Ø max. steel [mm]	4
possible cut-Ø max. piano wire [mm]	

*All data measured at 6 bar

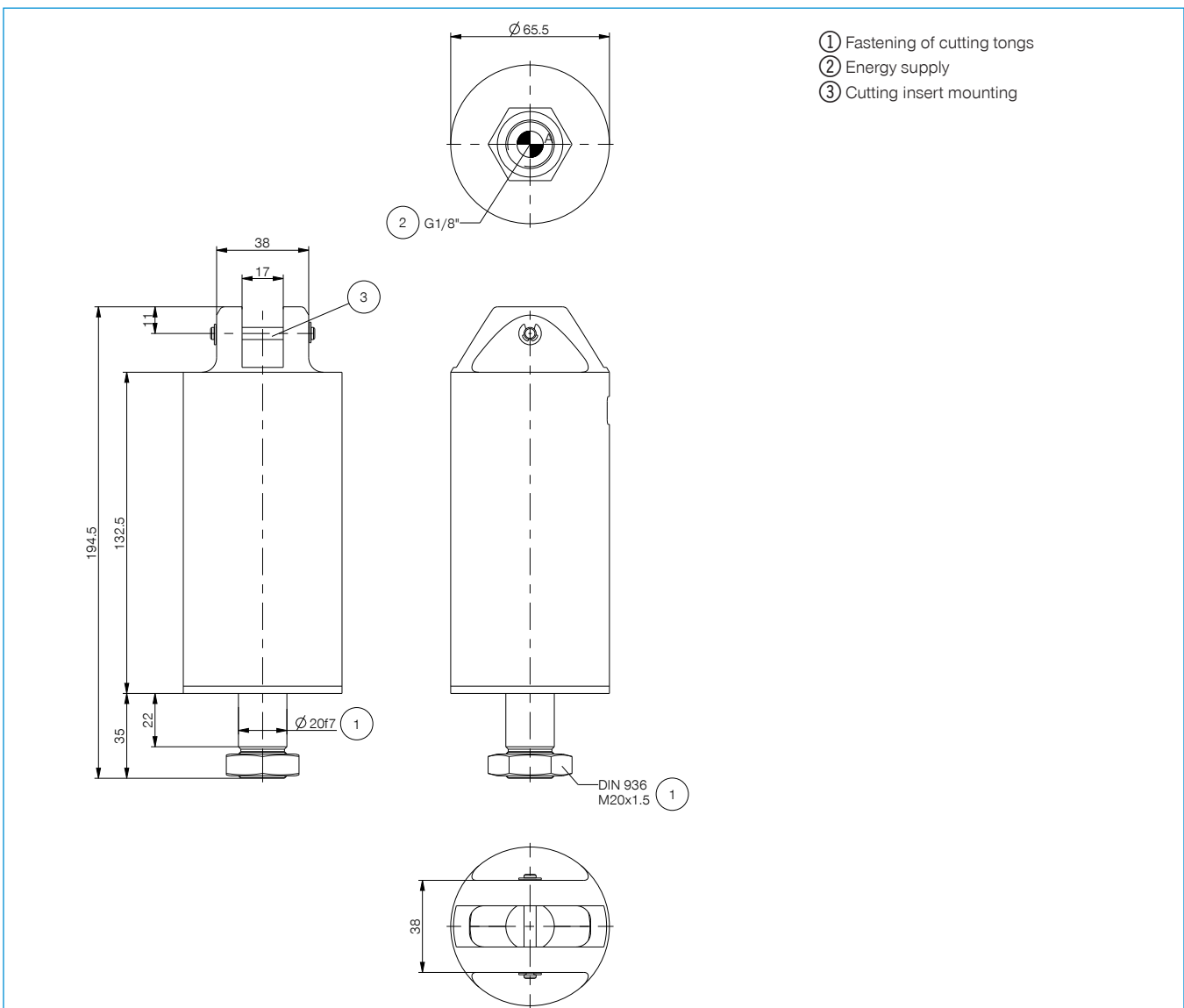

HANDLING COMPONENTS

CUTTING TONGS - ZK1000 SERIES CUTTING INSERTS

▶ CUTTING INSERTS FOR ZK1030

Cutting Insert 15° for plastics

BK1030-01

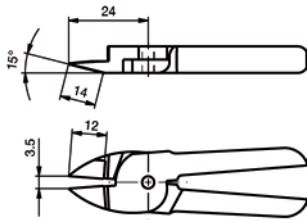

Cutting Insert 40° For Plastics

BK1030-02

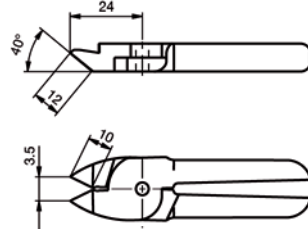

Cutting Insert 0° For Plastics

BK1030-03

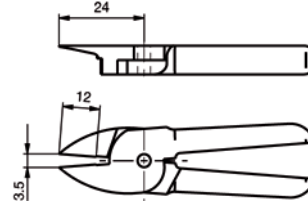

Cutting Tong For Plastics

BK1030-04

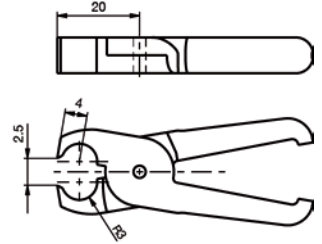

Cutting Insert 0° For Steel

BK1030-05

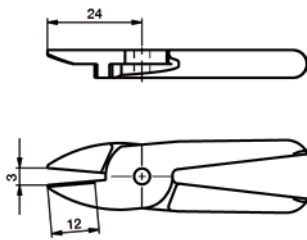

Cutting Insert 25° For Steel

BK1030-06

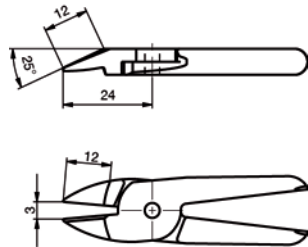

Carbide cutting insert 0° for steel

BK1030-07

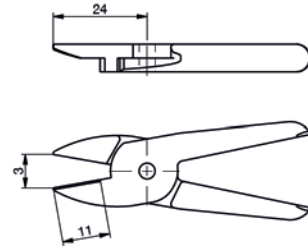

Carbide Cutting Insert 25° For Steel

BK1030-08

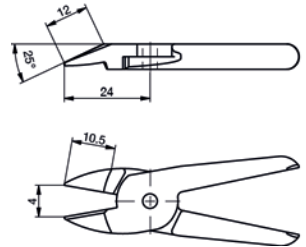

▶ CUTTING INSERTS FOR ZK1036

Cutting Insert 25° For Plastics

BK1036-01

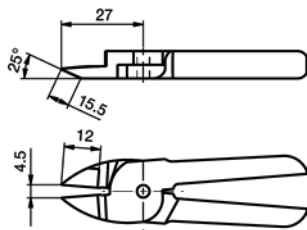

Cutting Insert 40° For Plastics

BK1036-02

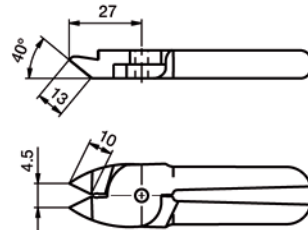

Cutting Insert 0° For Plastics

BK1036-03

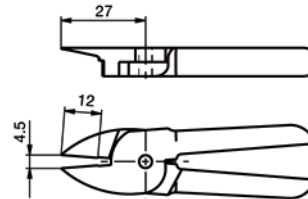

Cutting Tong For Plastics

BK1036-04

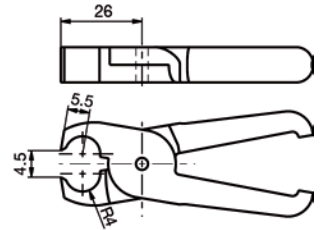

Cutting Insert 0° For Steel

BK1036-05

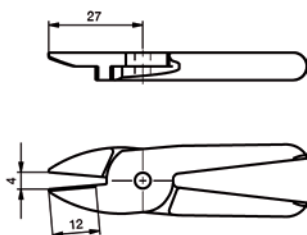

Cutting Insert 25° For Steel

BK1036-06

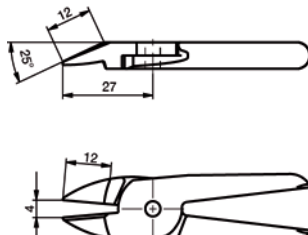

Carbide cutting insert 0° for steel

BK1036-07

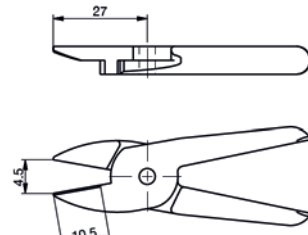

Carbide Cutting Insert 25° For Steel

BK1036-08

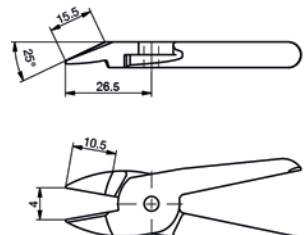

CUTTING INSERTS FOR ZK1045

Cutting Insert 15° for plastics

BK1045-01

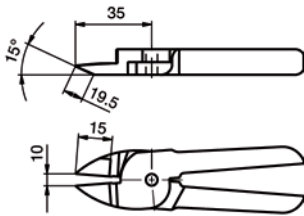

Cutting Insert 40° For Plastics

BK1045-02

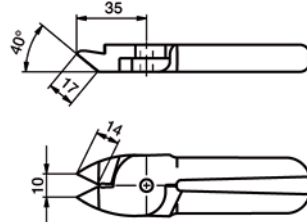

Cutting Insert 0° For Plastics

BK1045-03

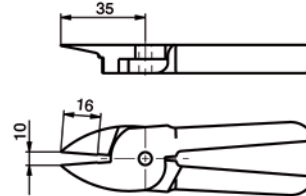

Cutting Tong For Plastics

BK1045-04

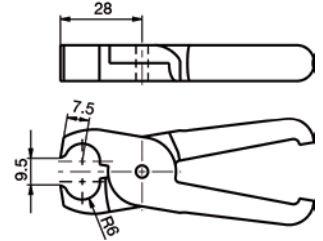

Cutting Insert 0° For Steel

BK1045-05

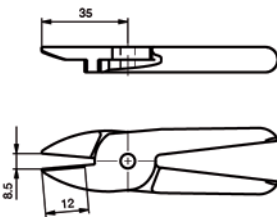

Cutting Insert 30° For Steel

BK1045-06

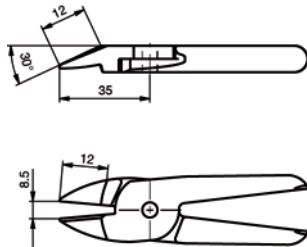

Carbide cutting insert 0° for steel

BK1045-07

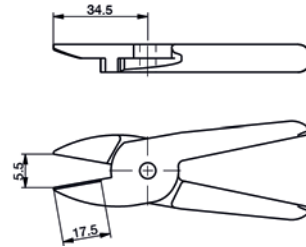

Carbide Cutting Insert 35° For Steel

BK1045-08

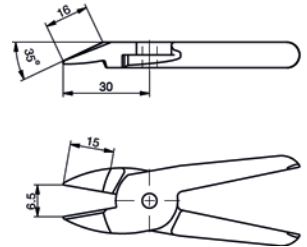

CUTTING INSERTS FOR ZK1065

Cutting Insert 15° for plastics

BK1065-01

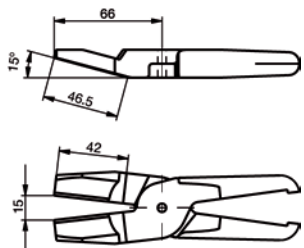

Cutting Insert 0° For Plastics

BK1065-02

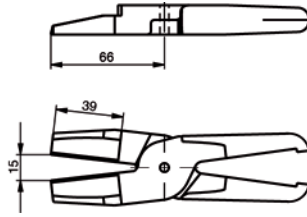

Cutting Insert 30° For Plastics

BK1065-03

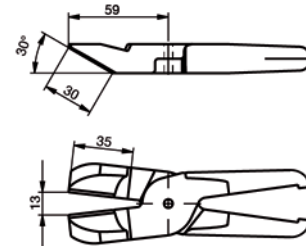

Cutting Tong For Plastics

BK1065-04

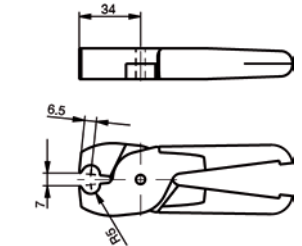

Cutting Insert 0° For Steel

BK1065-05

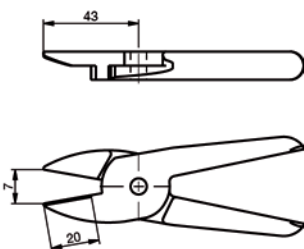

Cutting Insert 30° For Steel

BK1065-06

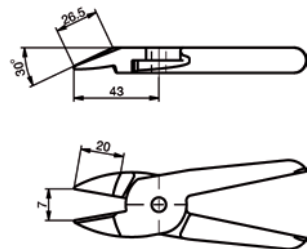

Carbide cutting insert 0° for steel

BK1065-07

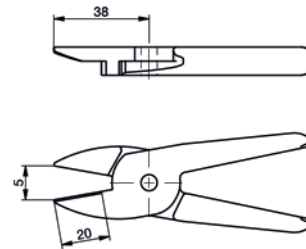

Carbide Cutting Insert 40° For Steel

BK1065-08

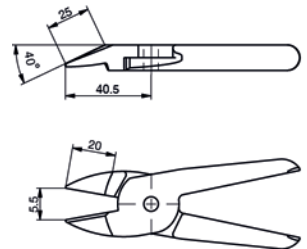

MCS MODULAR CONSTRUCTION SYSTEM

OVERVIEW OF SERIES

With the modular construction system MCS (Modular Construction System), a specific work piece solution can be found without any additional design effort. This can be done by the compatible single components. So, you can find profiles [2], compensating elements [5], and suction cups holders [6] in our product portfolio as well as gripper fingers [1] which are guaranteeing a firm grip of the work piece during the transportation.

The MCS is applied, where a low-cost but robust solution is required. The special feature of the system is its low weight compared to a conventional steel construction. So, a complex system can be designed or assembled at the workbench with no trouble.

In short, the more complex a work piece, the more benefits the MCS offers with regard to the cost incurred.







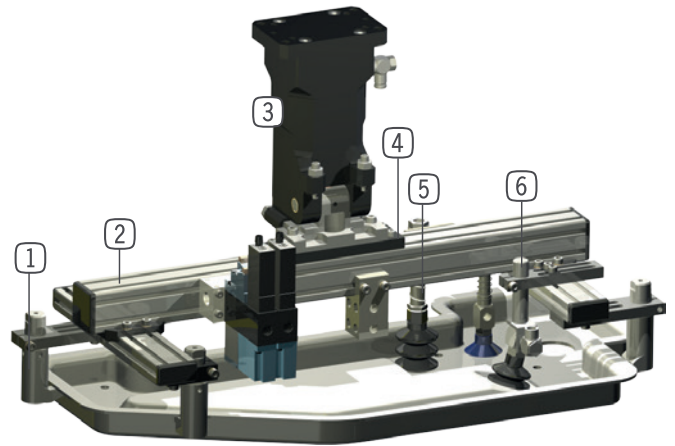













The MCS can be applied to various areas of handling components. The MCS is used for robot solutions which focus mainly to the load of robots as well as for pick and place applications and removal handling.

For the tool changers HWR and the angle pivot units SWM [8], standardized adapter plates [4] are available which enable a simple and low-cost connection to the MCS.

Particularly this combination with other Sommer-automatic components makes the modular construction system so attractive and utmost flexible.



► MCS MODULAR CONSTRUCTION SYSTEM

	Profile 10x20	114
	Profile 20x20	114
	Profile 20x40	115
	Profile 40x40	115
	Cover Cap	116
	Cross Clamp	116
	Angle fixing	117
	Slot Nut Pivoting	117
	Slot nut with ball	118
	Clamp	118
	Clamp adjustable	119
	Angle piece	119
	Joint angle piece	120
	Suction finger spring-loaded	121
	Suction finger	122
	Suction finger rotatable	123
	Suction finger rotatable	124
	Air Distributor 4-Connections	124
	Air Distributor 2x4-Connections	125
	Gripper fingers	125

MODULAR CONSTRUCTION SYSTEM

SERIES MCS

► PROFILE 10X20



► Special features

- Groove width 5mm
- Standard length 2000 mm
- Other lengths available on request

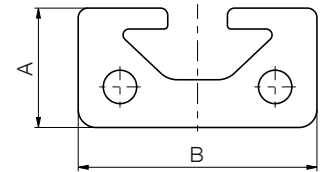

Order no.

► Technical Data

SO-10102000

Dimension A [mm]	10
Dimension B [mm]	20
Dimension L [mm]	2000
Weight [g/m]	350

► PROFILE 20X20



► Special features

- Groove width 5mm
- Standard length 2000 mm
- Other lengths available on request

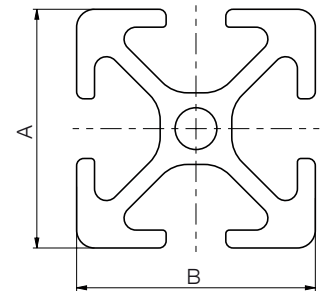

Order no.

► Technical Data

SO-10402000

Dimension A [mm]	20
Dimension B [mm]	20
Dimension L [mm]	2000
Weight [g/m]	490

► PROFILE 20X40



► Special features

- Groove width 5mm
- Standard length 2000 mm
- Other lengths available on request

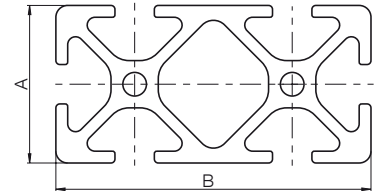

Order no.

► Technical Data

SO-10502000

Dimension A [mm]	20
Dimension B [mm]	40
Dimension L [mm]	2000
Weight [g/m]	950

► PROFILE 40X40



► Special features

- Groove width 5mm
- Standard length 2000 mm
- Other lengths available on request

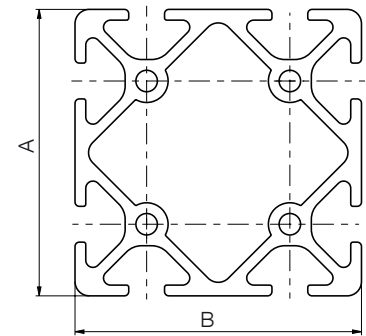

Order no.

► Technical Data

SO-10802000

Dimension A [mm]	40
Dimension B [mm]	40
Dimension L [mm]	2000
Weight [g/m]	1810

MODULAR CONSTRUCTION SYSTEM

SERIES MCS

▶ COVER CAP



▶ Special features

To cover the profile section ends

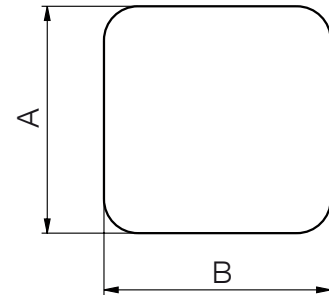

▶ Technical Data

Order no.	SO-11110020	SO-11120020	SO-11120040	SO-11140040
Dimension A [mm]	10	20	20	40
Dimension B [mm]	20	20	40	40

▶ CROSS CLAMP



▶ Special features

On both sides, the profiles are inserted into a groove. So a very high angle stability is ensured

Releasing the fixing on one profile side, the profile can be moved parallelly and set

The profile may be shifted in parallel and adjusted by loosening the mount on one side of the profile

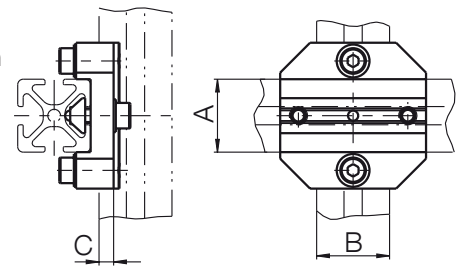

▶ Technical Data

Order no.	SO-13120020	SO-13120040	SO-13140040
Dimension A [mm]	20	20	40
Dimension B [mm]	20	40	40
Dimension C [mm]	4	4	4
Weight [g]	48	73	109

▶ ANGLE FIXING



▶ Special features

For simple 90° angle fixing with low stresses

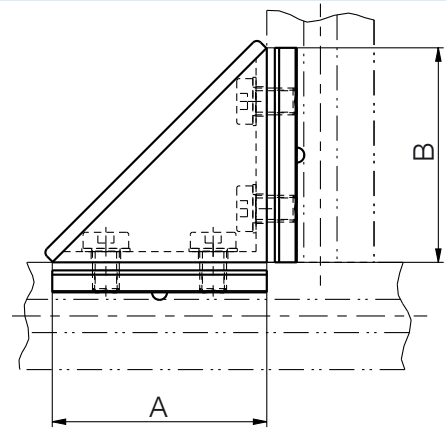

▶ Technical Data

Order no.	SO-13420020	SO-13440040
Dimension A [mm]	20	40
Dimension B [mm]	20	40
Weight [g]	25	60

▶ SLOT NUT PIVOTING



▶ Special features

All Slot nuts made of galvanised steel with strip for centering

Can be pivoted into any section of profile groove for normal fixing

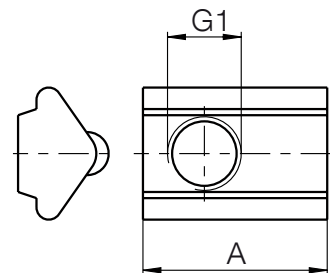

▶ Technical Data

Order no.	SO-14104000	SO-14105000
G1	M4	M5
Dimension A [mm]	12	12
Weight [g]	2	2

MODULAR CONSTRUCTION SYSTEM

SERIES MCS

▶ SLOT NUT WITH BALL



▶ Special features

All Slot nuts made of galvanised steel with wide profile guiding
 Inserted into the profile slot from the side for high stresses

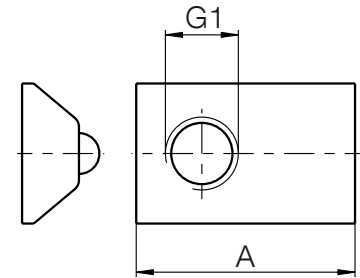

Order no.

▶ Technical Data

SO-14305000

G1

M5

Dimension A [mm]

15

Weight [g]

4

▶ CLAMP



▶ Special features

Rigid clamp for fixing to all profiles
 Standard with pivoting Slot nut and screws

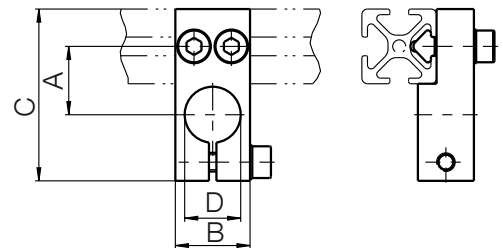

▶ Technical Data

Order no.

SO-23110017

SO-23115019

SO-23120022

Dimension A [mm]

17

19

22

Dimension B [mm]

16

20

25

Dimension C [mm]

39

46

51

Dimension D [mm]

10

15

20

Weight [g]

20

27

46

▶ CLAMP ADJUSTABLE

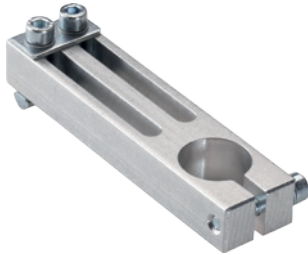

▶ Special features

Adjustable clamps for fixing to all profiles

Standard with pivoting Slot nut and screws

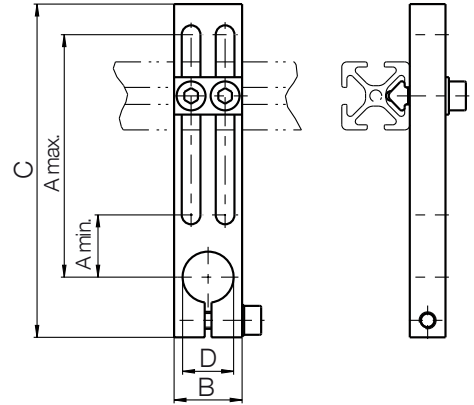

▶ Technical Data

Order no.	SO-23210057	SO-23215070	SO-23220072
Dimension A min. [mm]	17	19	22
Dimension A max. [mm]	57	70	72
Dimension B [mm]	16	20	25
Dimension C [mm]	81	98	103
Dimension D [mm]	10	15	20
Weight [g]	47	53	85

▶ ANGLE PIECE



▶ Special features

For adapting the following elements to right-angled surfaces

Suitable for jointed angle pieces, suction fingers and tongs

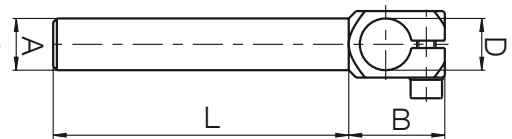

▶ Technical Data

Order no.	SO-25110030	SO-25110060	SO-25110090	SO-25115045	SO-25115090
Dimension A [mm]	10	10	10	15	15
Dimension B [mm]	20	20	20	27	27
Dimension D [mm]	10	10	10	15	15
Dimension L [mm]	30	60	90	45	90
Weight [g]	15	19	23	35	47

▶ Technical Data

Order no.	SO-25115130	SO-25120045	SO-25120090	SO-25120130
Dimension A [mm]	15	20	20	20
Dimension B [mm]	27	33	33	33
Dimension D [mm]	15	20	20	20
Dimension L [mm]	130	45	90	130
Weight [g]	55	68	90	114

MODULAR CONSTRUCTION SYSTEM

SERIES MCS

▶ JOINT ANGLE PIECE

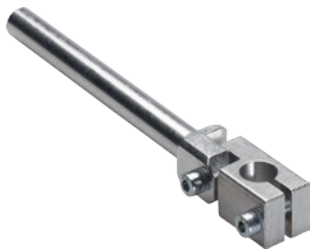

▶ Special features

For adapting the following elements to inclined surfaces

Suitable for angle pieces and suction fingers

Joint swivels through 180°

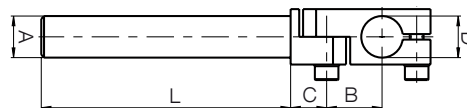

▶ Technical Data

Order no.	SO-26110030	SO-26110060	SO-26110090	SO-26115045	SO-26115090
Dimension A [mm]	10	10	10	15	15
Dimension B [mm]	16	16	16	22	22
Dimension C [mm]	11	11	11	14	14
Dimension D [mm]	10	10	10	15	15
Dimension L [mm]	30	60	90	45	90
Weight [g]	26	32	39	60	70

▶ Technical Data

Order no.	SO-26115130	SO-26120045	SO-26120090	SO-26120130
Dimension A [mm]	15	20	20	20
Dimension B [mm]	22	26	26	26
Dimension C [mm]	14	16	16	16
Dimension D [mm]	15	20	20	20
Dimension L [mm]	130	45	90	130
Weight [g]	78	118	144	168

▶ SUCTION FINGER SPRING-LOADED



▶ Special features

Spring-loaded suction cups for contact surfaces at right angles to suction cup

Suitable for mini and bellows cups

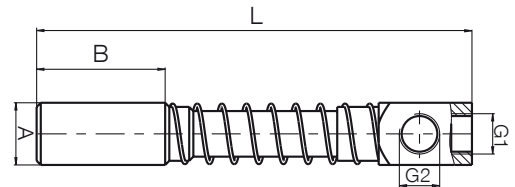

▶ Technical Data

Order no.	SO-30311010	SO-30311020	SO-30322015	SO-30322035	SO-30323015
G1	M5	M5	G1/8"	G1/8"	G1/4"
G2	M5	M5	G1/8"	G1/8"	G1/8"
Dimension A [mm]	10	10	15	15	15
Dimension B [mm]	26	26	32	32	32
Dimension L min. [mm]	48	56	65	70	67
Dimension L max. [mm]	58	76	80	105	82
Weight [g]	12	14	32	35	39

▶ Technical Data

Order no.	SO-30323035	SO-30332020	SO-30332040	SO-30333020	SO-30333040
G1	G1/4"	G1/8"	G1/8"	G1/4"	G1/4"
G2	G1/8"	G1/8"	G1/8"	G1/4"	G1/4"
Dimension A [mm]	15	20	20	20	20
Dimension B [mm]	32	53	53	53	53
Dimension L min. [mm]	72	89	95	93	99
Dimension L max. [mm]	107	109	135	103	139
Weight [g]	42	74	90	61	77

MODULAR CONSTRUCTION SYSTEM

SERIES MCS

► SUCTION FINGER



► Special features

Rigid suction finger for rectangular contact surfaces to suction cup
 Suitable for mini and bellows cups

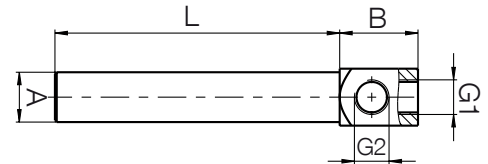

	► Technical Data				
Order no.	SO-30111030	SO-30111060	SO-30111090	SO-30122045	SO-30122090
G1	M5	M5	M5	G1/8"	G1/8"
G2	M5	M5	M5	G1/8"	G1/8"
Dimension A [mm]	10	10	10	15	15
Dimension B [mm]	14	14	14	20	20
Dimension L [mm]	30	60	90	45	90
Weight [g]	9	14	21	26	38

	► Technical Data				
Order no.	SO-30122130	SO-30123045	SO-30123090	SO-30123130	SO-30132045
G1	G1/8"	G1/4"	G1/4"	G1/4"	G1/8"
G2	G1/8"	G1/8"	G1/8"	G1/8"	G1/8"
Dimension A [mm]	15	15	15	15	20
Dimension B [mm]	20	24	24	24	24
Dimension L [mm]	130	45	90	130	45
Weight [g]	49	30	42	50	57

	► Technical Data				
Order no.	SO-30132090	SO-30132130	SO-30133045	SO-30133090	SO-30133130
G1	G1/8"	G1/8"	G1/4"	G1/4"	G1/4"
G2	G1/8"	G1/8"	G1/4"	G1/4"	G1/4"
Dimension A [mm]	20	20	20	20	20
Dimension B [mm]	24	24	28	28	28
Dimension L [mm]	90	130	45	90	130
Weight [g]	83	109	52	79	105

▶ SUCTION FINGER ROTATABLE

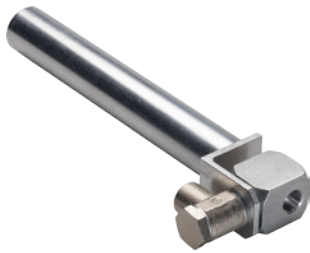

▶ Special features

Suction fingers with swivel head for inclined surfaces to suction cup, suitable for mini and bellows cups

The suction cup can be adjusted for inclined surfaces up to 45°

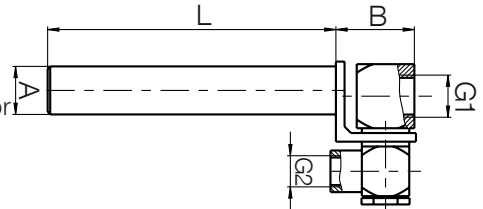

Order no.	▶ Technical Data				
	SO-30211030	SO-30211060	SO-30211090	SO-30222045	SO-30222090
G1	M5	M5	M5	G1/8"	G1/8"
G2	M5	M5	M5	G1/8"	G1/8"
Dimension A [mm]	10	10	10	15	15
Dimension B [mm]	16	16	16	24	24
Dimension L [mm]	30	60	90	45	90
Weight [g]	17	21	26	61	73

Order no.	▶ Technical Data				
	SO-30222130	SO-30223045	SO-30223090	SO-30223130	SO-30232045
G1	G1/8"	G1/4"	G1/4"	G1/4"	G1/8"
G2	G1/8"	G1/8"	G1/8"	G1/8"	G1/8"
Dimension A [mm]	15	15	15	15	20
Dimension B [mm]	24	25	25	25	30
Dimension L [mm]	130	45	90	130	45
Weight [g]	83	65	78	88	81

Order no.	▶ Technical Data				
	SO-30232090	SO-30232130	SO-30233045	SO-30233090	SO-30233130
G1	G1/8"	G1/8"	G1/4"	G1/4"	G1/4"
G2	G1/8"	G1/8"	G1/4"	G1/4"	G1/4"
Dimension A [mm]	20	20	20	20	20
Dimension B [mm]	30	30	30	30	30
Dimension L [mm]	90	130	45	90	130
Weight [g]	116	138	104	139	161

MODULAR CONSTRUCTION SYSTEM

SERIES MCS

► SUCTION FINGER ROTATABLE

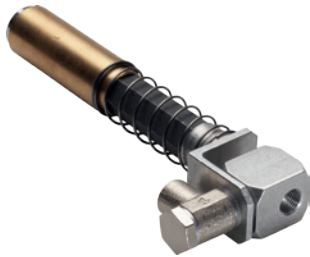

► Special features

Spring-loaded suction finger with swivel head for contact inclined surfaces to suction cup

Suitable for mini and bellows cups

The suction cup can be adjusted for inclined surfaces up to 45°

Secured against rotation

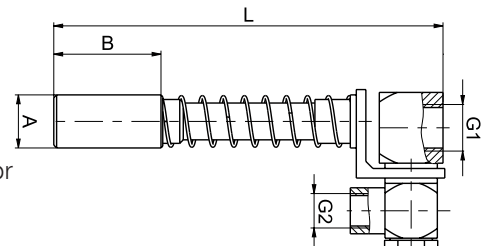

► Technical Data

Order no.	SO-30411010	SO-30411020	SO-30422015	SO-30422035	SO-30423015
G1	M5	M5	G1/8"	G1/8"	G1/4"
G2	M5	M5	G1/8"	G1/8"	G1/8"
Dimension A [mm]	10	10	15	15	15
Dimension B [mm]	26	26	32	32	32
Dimension L min. [mm]	52	60	70	75	72
Dimension L max. [mm]	62	80	85	110	87
Weight [g]	29	30	76	77	81

► Technical Data

Order no.	SO-30423035	SO-30432020	SO-30432040	SO-30433020	SO-30433040
G1	G1/4"	G1/8"	G1/8"	G1/4"	G1/4"
G2	G1/8"	G1/8"	G1/8"	G1/4"	G1/4"
Dimension A [mm]	15	20	20	20	20
Dimension B [mm]	32	53	53	53	53
Dimension L min. [mm]	77	97	103	99	105
Dimension L max. [mm]	112	117	143	119	145
Weight [g]	82	145	146	168	169

► AIR DISTRIBUTOR 4-CONNECTIONS



► Special features

1 air cycle, 4 connections

To distribute compressed air and vacuum

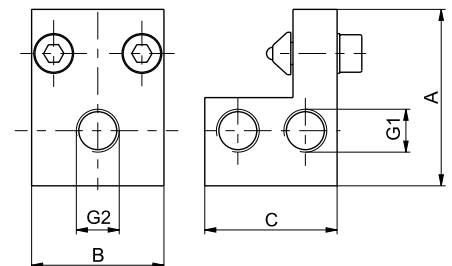

► Technical Data

Order no.	SO-35101004
G1	G1/8"
G2	G1/8"
Dimension A [mm]	40
Dimension B [mm]	30
Dimension C [mm]	30
Weight [g]	86

► AIR DISTRIBUTOR 2X4-CONNECTIONS



► Special features

2 air cycle, 2x4 connections
To distribute compressed air and vacuum

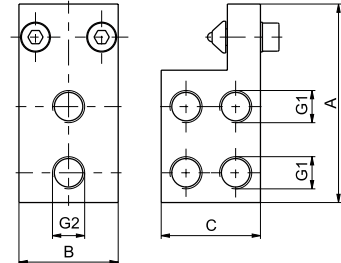

Order no.

► Technical Data

SO-35102004

G1	G1/8"
G2	G1/8"
Dimension A [mm]	60
Dimension B [mm]	30
Dimension C [mm]	30
Weight [g]	133

► GRIPPER FINGERS



► Special features

Swivel angle 90°
Torque 90 Ncm

Ⓐ Closing/Gripping
Ⓑ Opening

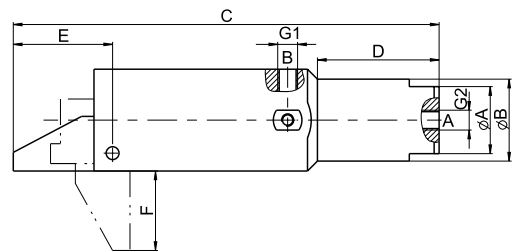

Order no.

► Technical Data

SO-43120090







G1	M5
G2	M5
Dimension A [mm]	20
Dimension B [mm]	25
Dimension C [mm]	105
Dimension D [mm]	30
Dimension E [mm]	24
Dimension F [mm]	19
Weight [g]	130

ACCESORIES

OVERVIEW OF SERIES



▶ ACCESSORIES

	Series IF - Filters	128
	Series SV - Flow control valve	129
	Series SD - Silencer	130
	Series GV - Straight fittings - barb style connection	130
	Series GV - Straight fittings - quick style connection	131
	Series WV - Angled fittings - quick style connection	131
	Seal	132
	Connection plate	132
	Cover plate	133
	Clamping tongs	133

ACCESORIES

SERIES IF / SV

► SERIES IF - FILTERS



► Special features

Coarse particle inline filter
Easy to fit

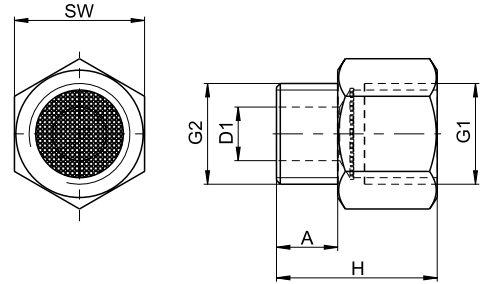

► Technical Data

Order no.	IF1-4	IF1-8
G1	G1/4"	G1/8"
G2	G1/4"	G1/8"
Dimension A [mm]	8	6
Dimension D1 [mm]	7	5
Dimension H [mm]	21	16
SW [mm]	17	14

► SERIES IF - FILTERS



► Special features

Easy tube fitting
Degree of pollution can be seen through transparent housing

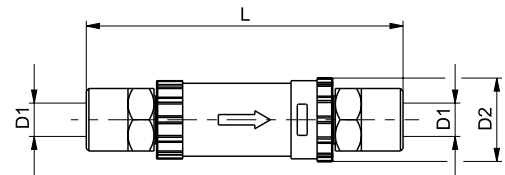

► Technical Data

Order no.	IF6-4	IF8-6
Dimension D1 [mm]	6	8
Dimension D2 [mm]	16	23
Dimension L [mm]	61	68

► SERIES SV - FLOW CONTROL VALVE



► Special features

- Version with internal thread on top
- Response characteristics depend on flow rate
- Closes vacuum line for suction grippers not in use
- Maintains system vacuum

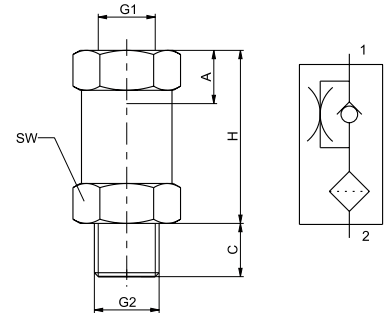

► Technical Data

Order no.	SV14AI	SV18AI
G1	G1/4"	G1/8"
G2	G1/4"	G1/8"
Dimension A [mm]	11	8.5
Dimension C [mm]	10	8
Dimension H [mm]	26	26
SW [mm]	17	14

► SERIES SV - FLOW CONTROL VALVE



► Special features

- Version with internal thread on top
- Response characteristics depend on flow rate
- Closes vacuum line for suction grippers not in use
- Maintains system vacuum

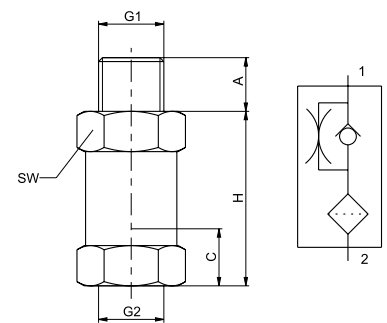

► Technical Data

Order no.	SV14IA	SV18IA
G1	G1/4"	G1/8"
G2	G1/4"	G1/8"
Dimension A [mm]	10	8
Dimension C [mm]	11	8.5
Dimension H [mm]	26	26
SW [mm]	17	14

ACCESORIES

SERIES SD / GV / WV

► SERIES SD - SILENCER



► Special features

To reduce noise
For VG1/8 vacuum generator

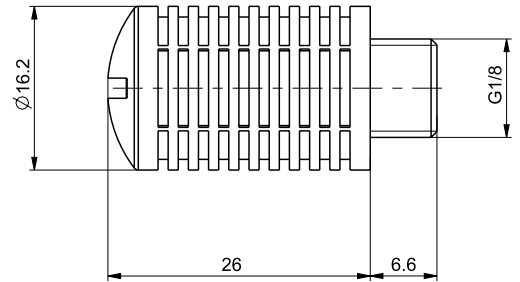

► Technical Data

Order no.	SD18KS
Fixing thread	G1/8"

► SERIES GV - STRAIGHT FITTINGS - BARB-STYLE CONNECTION

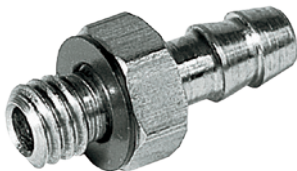

► Special features

For assembling with hose clips
Straight version

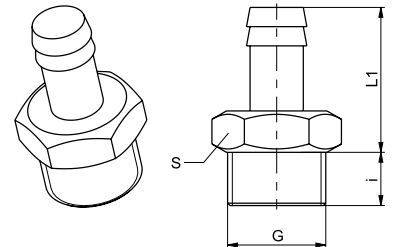

► Technical Data

Order no.	GVM3	GV1-8X5ID	GV1-8X6ID	GV1-8X8ID	GV1-4X8ID
Fixing thread	M3	G1/8"	G1/8"	G1/8"	G1/4"
Inside-Ø for hose [mm]	3	5	6	8	8
Dimension i [mm]	2.7	6	6	6	8
Dimension L1 [mm]	7.2	24	24	24	24.5
S [mm]	4.5	13	13	13	17

► Technical Data

Order no.	GV1-4X10ID	GV3-8X13ID	GV1-2X13ID	GV1-2X16ID
Fixing thread	G1/4"	G3/8"	G1/2"	G1/2"
Inside-Ø for hose [mm]	10	13	13	16
Dimension i [mm]	8	9	10	10
Dimension L1 [mm]	24.5	24.5	25	29.5
S [mm]	17	19	24	24

► SERIES GV - STRAIGHT FITTINGS - QUICK CONNECT STYLE



► Special features

Cost reduction through quick assembly and disassembly

Straight version

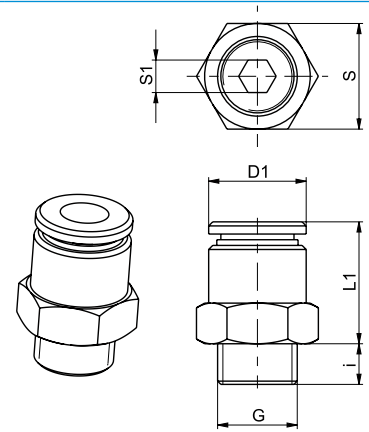

► Technical Data

Order no.	GVM5	GV1-8X4	GV1-8X6	GV1-8X8	GV1-4X6	GV1-4X8
Fixing thread	M5	G1/8"	G1/8"	G1/8"	G1/4"	G1/4"
Outside-Ø for hose [mm]	4	4	6	8	6	8
Dimension D1 [mm]	8	10	12	14	12	14
Dimension i [mm]	3.5	5	5	5	7	7
Dimension L1 [mm]	16.5	14	15	20	14.5	16
S [mm]	8	13	13	14	17	17
S1 [mm]	2.5	3	4	5	4	6

► WV SERIES - ANGLED FITTINGS- QUICK CONNECT STYLE



► Special features

Cost reduction through quick assembly and disassembly

Angled and swivel-mounted

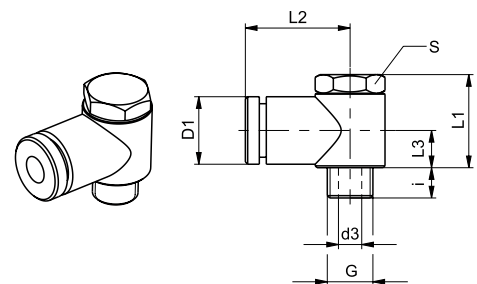

► Technical Data

Order no.	WVM5	WV1-8X4	WV1-8X6	WV1-8X8	WV1-4X6	WV1-4X8
Fixing thread	M5	G1/8"	G1/8"	G1/8"	G1/4"	G1/4"
Outside-Ø for hose [mm]	4	4	6	8	6	8
Dimension D1 [mm]	8	10	12	14	12	14
Dimension d3 [mm]	2	5	5	5	7	7
Dimension i [mm]	4	6.5	6.5	6.5	8	8
Dimension L1 [mm]	14	20	20	20	21	21
Dimension L2 [mm]	17	20.5	21.5	23.5	23.5	25.5
Dimension L3 [mm]	5.3	8	8	8	8	8
S [mm]	8	14	14	14	17	17
S4 [mm]	9	14	14	14	18	18

ACCESORIES

SERIES ZUB

► SEAL



► Special features

Material: polyamide
To 90°C

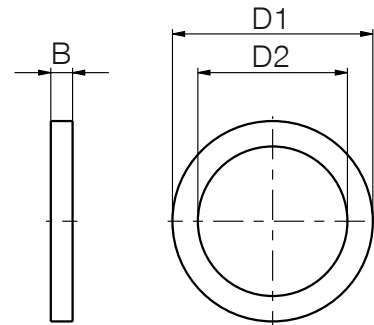

► Technical Data

Order no.	ZUB0034	ZUB0035	ZUB0036
Dimension B [mm]	1	1.5	1.5
Dimension D1 [mm]	8	13.8	17
Dimension D2 [mm]	5.1	10.3	13.5

► AIR CONNECTION



► Special features

To create compact ejector blocks
Central compressed air feed

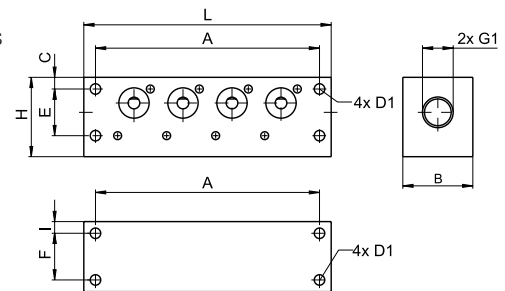

► Technical Data

Order no.	ZUB0007	ZUB0008	ZUB0010	ZUB0011
G1	G1/4"-IG	G1/4"-IG	G1/2"-IG	G1/2"-IG
Dimension A [mm]	54	96	62	108
Dimension B [mm]	30	30	38	38
Dimension C [mm]	5	5	8	8
Dimension D1 [mm]	4.5	4.5	7	7
Dimension E [mm]	20	20	34	34
Dimension F [mm]	20	20		
Dimension H [mm]	34	34	49.5	49.5
Dimension I [mm]	5	5	7	7
Dimension L [mm]	64	106	78	124
No. of outlets [Pice]	2	4	2	4
Weight [g]	180	281	375	595
compatible with	2xKE15	4xKE15	2xKE25	4xKE25

▶ COVER PLATE



▶ Special features

To close connections not used by ejectors

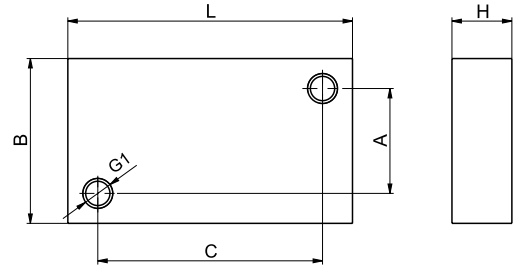

▶ Technical Data

Order no.	ZUB0009	ZUB0012
G1	M3	M4
Dimension A [mm]	14	14
Dimension B [mm]	20	22
Dimension C [mm]	20	30
Dimension H [mm]	6	8
Dimension L [mm]	26	38
compatible with	ZUB0007-ZUB0008	ZUB0010-ZUB0011

▶ CLAMPING TONGS ZUB0033



▶ Special features

Clamping tongs with side cutters for use where space is limited
Suitable for ear clamps in OV, SFO and SF suction cup Series

USAGE NOTE

GENERAL

The contents of this catalog are not legally binding and are intended solely for informational purposes. Any final agreement will be in the form of a written order confirmation from ZIMMER GMBH, which occurs only subject to the respective current General Terms and Conditions of Sale and Delivery of ZIMMER GMBH. These can be found online at www.zimmer-group.com.

All of the products listed in this catalog are designed for their intended use, e.g. machines for automation. The recognized technical regulations for safety and professional work must be followed for use and installation. Furthermore, the respective laws, guidelines from TÜV, guidelines from the respective trade association and VDE stipulations shall apply.

The technical data listed in this catalog must be observed by the user. The conditions of use may not fall below or exceed the specified data. If information is missing, it cannot be assumed that there are no upper or lower limits or no limitations for specific use cases. Consultation is required in these cases.

Disposal is not included in the price, which would have to be taken into account accordingly in the event of return to or disposal by ZIMMER GMBH.

TECHNICAL DATA AND FIGURES

The technical data and figures have been compiled with great care and to the best of our knowledge. We cannot guarantee that the information is up to date, correct or complete.

The specifications and information—such as figures, drawings, descriptions, dimensions, weights, materials, technical and other performance data and the described products and services—contained in general product descriptions, ZIMMER GMBH catalogs, brochures and price lists in any form are subject to change and may be modified or updated at any time without prior notification. They are binding only to the extent expressly specified in a contract or order confirmation. Slight deviations from such descriptive product information shall be considered approved and shall not affect fulfillment of agreements insofar as they are reasonable for the customer.

LIABILITY

Products from Zimmer Group are subject to the German Product Liability Act. This catalog does not contain any guarantees, assurances of quality or procurement agreements for the products it depicts, neither expressly nor implied, including for the availability of products. Advertising statements relating to quality features, properties or applications for the products are not legally binding.

To the extent permitted by law, ZIMMER GMBH is exempt from any liability for direct or indirect damage, subsequent damage and requests of any kind or on any legal basis resulting from the use of information contained in this catalogue.

TRADEMARK, COPYRIGHT AND REPRODUCTION

The depiction of commercial property rights in this catalog—such as brands, logos, registered trademarks or patents—does not include the granting of licenses or use rights. Their use is not permitted without the expressed written agreement of ZIMMER GMBH. All contents of this catalog are the intellectual property of ZIMMER GMBH. For the purposes of copyright, any unlawful use of intellectual property, including excerpts, is prohibited. Reprinting, copying or translating (including in the form of excerpts) are permitted only with the prior written consent of ZIMMER GMBH.

STANDARDS

Zimmer Group has a quality management system certified in accordance with ISO 9001:2008. Zimmer Group has an environmental management system certified in accordance with ISO 14001:2004.

USAGE NOTE

INDIVIDUAL

DECLARATION OF INCORPORATION IN TERMS OF THE EC DIRECTIVE 2006/42/EC ON MACHINERY (ANNEX II 1 B)

We hereby declare that our elements meet the following basic requirements of the Machinery Directive 2006/42/EC as an incomplete machine

No.1.1.2., No.1.1.3., No.1.1.5., No.1.3.2, No. 1.3.4, No. 1.3.7, No.1.5.3, No.1.5.4, No.1.5.8., No.1.6.4, No.1.7.1, No.1.7.3, No.1.7.4.

We also declare that the specific technical documents were produced in accordance with Annex VII Part B of this Directive. We undertake to provide the market supervisory bodies with electronic versions of the incomplete machine's special documents via our documentation department should they have reason to request them.

The incomplete machine may only be commissioned if the machine or system in which the incomplete machine is to be installed has been determined to satisfy the conditions of the Machinery Directive 2006/42/EC and the EC Declaration of Conformity has been produced in accordance with Annex II A.

The contents and data correspond to the status as of printing. Edition 05/2016.

This catalog was created with great care and all information has been checked for accuracy. However, we assume no liability for incorrect or incomplete information. Zimmer Group reserves the right to technical changes and improvements through constant ongoing development of products and services. All text, images, depictions and illustrations in this catalog are the property of Zimmer Group and protected by copyright. Any duplicating, editing, changing, translating, filming, processing or saving in electronic systems is prohibited without the consent of Zimmer Group.