

Hoses for the Food & Pharma Industry



Hoses & Connection Systems for applications in the Food & Pharma Industry

 **MASTERFLEX**
Connecting Values

A MASTERFLEX GROUP COMPANY

Masterflex – Your Partner in High-tech Hose Systems

Production facilities for the pharma and food industries are subject to stringent regulations and high standards in terms of materials used. Hoses must fulfil the most stringent of hygiene requirements in order to guarantee the safe processing of products to be manufactured. Masterflex products leave nothing to be desired where the highest requirements for quality, hygiene, abrasion resistance, flexibility and load-bearing capacity are placed upon Flow-through connections. Masterflex hoses and connectors comply with the latest food and pharma industry standards and are tried, tested and certified.

This brochure provides an overview of our products, which are especially designed for industrial challenges such as suction, transportation and supply of various substances - e.g., bulk goods, powder, dusts, granulates, pigments, capsules, tablets, etc. in the food and pharma industries. It also provides some sample applications to give you an insight into the many potential uses of our hoses.

Contents

Certified hose quality from Masterflex	3
Master-PUR L-F Food	4
Master-PUR L-F Food A	5
Master-PUR L Food	6
Master-PUR L Food A	7
Master-PUR L Food A Multi	8
Master-PUR H Food	9
Sample applications: Production of bakery products	10
Master-PUR H Food A	11
Master-PUR H Food A Multi	12
Master-PUR HX Food	13
Master-PUR HX Food A	14
Master-PUR HX Food A Multi	15
Polderflex PUR Food	16
Sample applications: Production of confectionary products	17
Polderflex PUR Food A	18
Polderflex PUR Food A Multi	19
Master-PUR Flat H Food	20
Master-SIL SD Food	21
Master-Grip Double Wire Clamp, screw-fitting	22
Combiflex PU Cone Flange Food	23
Sample applications: Milk powder & whey powder production	24
Combiflex PU Fixed Flange Food	25
Combiflex PU Swivel Flange Food	26
Combiflex PU Threaded Sockets Food	27
Quick-Fix Clamp for Cone Flanges	28
Combiflex Clamp Connection Food	29
Combiflex Clamp Ring Seal	30
Sample applications: Pharmaceuticals manufacturing	31
Combiflex Clamp Connection Hinged Clamp	32
Combiflex VA Threaded Sockets Food	33
Combiflex Dairy Fitting Threaded Hose Sockets	34
Combiflex Dairy Fitting Cone Sockets	35
Combiflex Dairy Fitting Ring Seal	36
Sample applications: Beauty and household cleaning products	37
templine® -A Heated Hoses	38
templine® -R Heated Hoses	39
templine® -B Heated Hoses	40
templine® -F Heated Hoses	41
templine® -H Heated Hoses	42
templine® -A/ -R/ -B VARIO Heated Hoses	43

Certified hose quality from Masterflex

Not all hoses are suitable for transporting foodstuffs. Only hoses that comply with strict regulations and directives are permitted for transportation of coffee, sugar or even milk powder from A to B.

All Masterflex food-grade hoses are certified in accordance with EU regulation 10/2011 in relation to food-grade quality

Masterflex has provided certified, food-grade hoses for many years, along with compatible, high-quality connection and fastening elements. Thus, all food hoses are manufactured in accordance with EU regulation no. 10/2011 in relation to food grade quality.

This certification applies to the complete hose line, as well as all food connecting elements. All permanently antistatic Masterflex food hoses are also certified. The walls of Food A hoses have a surface resistance of $R_o < 10^9$ Ohm; hence, their discharge capacity conforms to Technical Rules for Hazardous Substances (TRGS 727) (ATEX 2014/34EU).

Since 2011, in addition to EC framework regulation 1935/2004, as well as EC regulation 2023/2006 on “good manufacturing practice”, the activities of the food processing industry have been regulated by EU regulation no. 10/2011 on the “placing on the market of plastic materials and articles”, also known as the “Plastics Implementation Measure (PIM)” in particular.

In addition to the three standards mentioned, Masterflex food hoses also comply with FDA (US Food and Drug Administration) guidelines, as well as the German Food and Feed Code (LFGB).

All of the materials used for Masterflex food hoses and connecting elements exactly fulfil these demanding national and international food product regulations and are ideally suited for use in the food and pharma industries. This has also been certified by an independent institute. Masterflex employs a stainless steel wire spiral for all of its food hoses. Thus, the food grade quality of the conveyed medium is maintained, even in the event of abrasion of the wall material underneath the wire spiral.

Thanks to their optimised moulding, our food hoses leave almost no material residue. They are much easier to clean and can also be assembled bi-directionally.



Master-PUR L-F Food

PU Suction & Transport Hose, super lightweight, extremely flexible, food-grade quality acc. to EU 10/2011 and FDA

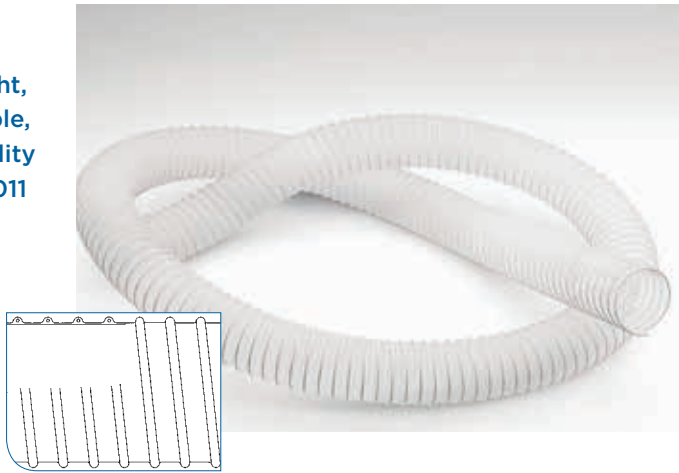

Connections:



Material

- spiral: spring steel wire (stainless steel 1.4310)
- wall: pure polyether polyurethane, food-grade quality (FDA)
- wall thickness between spirals approx. 0.5 mm

Applications

- Pharmaceutical industry
- Chemicals industry
- Food industry

Temperature Range

- -40°C to +90°C
- peaks to +125°C

Properties

- materials comply with the following food regulations:
 - FDA 21 CFR §177.2600
 - FDA 21 CFR §178.2010

- Approved for food-grade categories: A, B, C, D1, D2, E (contact durations acc. to Test Report)
- The hose conforms with EU Guideline 10/2011
- smallest bending radii
- optimum flow characteristics
- highly flexible
- abrasion-resistant
- odourless/tasteless
- microbe and hydrolysis-resistant
- halogen and plasticizer-free
- good chemical resistance
- high tensile strength
- generally good UV and ozone resistance
- acc. to TRGS 727 and ATEX 2014/34 EU, with earthing at both ends of the spiral for non-flammable dust/bulk solids in Zone 22. For gases/liquids with low conductivity of electrostatic charges in Zone 2.
- very light

DN	op. pressure bar	vacuum bar	bend radius mm	outer Ø mm	weight/m kg	article no.	max. production length m
40	0,82	0,24	20	46	0,28	310-040-501	25
50	0,78	0,2	24	56	0,33	310-050-501	25
51	0,78	0,2	25	57	0,34	310-051-501	25
60	0,76	0,19	35	68	0,35	310-060-501	25
75	0,61	0,13	42	82	0,51	310-075-501	25
76	0,61	0,13	43	83	0,53	310-076-501	25
80	0,53	0,13	45	88	0,53	310-080-501	25
90	0,46	0,09	50	99	0,6	310-090-501	25
100	0,46	0,09	54	107	0,68	310-100-501	25
102	0,46	0,09	55	108	0,69	310-102-501	25
110	0,38	0,09	60	119	0,73	310-110-501	25
120	0,38	0,09	65	129	0,82	310-120-501	25
125	0,38	0,09	68	132	0,84	310-125-501	25
127	0,38	0,09	70	134	0,85	310-127-501	25
150	0,3	0,06	79	157	1	310-150-501	25
152	0,3	0,06	80	159	1,02	310-152-501	25
180	0,23	0,06	95	189	1,38	310-180-501	25
200	0,23	0,06	104	207	1,5	310-200-501	25
203	0,23	0,06	105	210	1,52	310-203-501	25
250	0,15	0,03	128	256	1,64	310-250-501	25
254	0,15	0,03	130	260	1,64	310-254-501	25
300	0,14	0,03	155	310	1,78	310-300-501	25
350	0,12	0,03	180	360	2,44	310-350-501	25
400	0,12	0,03	210	410	3,04	310-400-501	25

All data refers to a medium and ambient temperature of +20 °C. * Refers to the inner hose lining. Subject to technical changes and colour deviations

Master-PUR L-F Food A

PU Suction & Transport Hose, super lightweight, food-grade quality acc. to EU 10/2011 and FDA, permanently antistatic

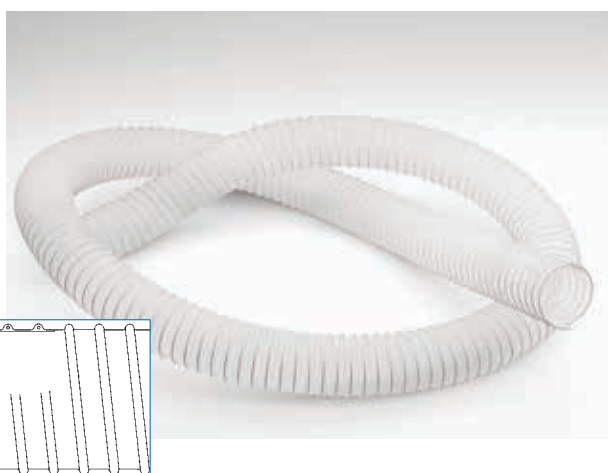

Material

- spiral: spring steel wire (stainless steel 1.4310)
- wall: pure polyether polyurethane, food-grade (FDA), with non-migratory permanent antistatic agent
- wall thickness between spirals approx. 0.5 mm

Applications

- Pharmaceutical industry
- Chemicals industry
- Food industry

Temperature Range

- -40°C to +90°C
- peaks to +125°C

Connections:



Properties

- approved acc. to TRGS 727 and ATEX 2014/34 EU
- permanently antistatic, surface resistance < 10⁹ Ohm
- The hose conforms with EU Guideline 10/2011
- smallest bending radii
- optimum flow characteristics
- highly flexible
- abrasion-resistant
- odourless/tasteless
- microbe and hydrolysis-resistant
- halogen and plasticizer-free
- good chemical resistance
- high tensile strength
- generally good UV and ozone resistance
- The material of the wall complies with the FDA food regulations 21 CFR § 177.1680 and 21 CFR § 177.2600
- very light
- Approved for food-grade category: E (contact duration acc. to Test Report).

DN	op. pressure bar	vacuum bar	bend radius mm	outer Ø mm	weight/m kg	article no.	max. production length m
40	0,82	0,24	20	46	0,28	310-040-581	25
50	0,78	0,2	24	56	0,33	310-050-581	25
51	0,78	0,2	25	57	0,34	310-051-581	25
60	0,76	0,19	35	68	0,35	310-060-581	25
75	0,61	0,13	42	82	0,51	310-075-581	25
76	0,61	0,13	43	83	0,53	310-076-581	25
80	0,53	0,13	45	88	0,53	310-080-581	25
90	0,46	0,09	50	99	0,6	310-090-581	25
100	0,46	0,09	54	106	0,68	310-100-581	25
102	0,46	0,09	55	108	0,69	310-102-581	25
110	0,38	0,09	60	119	0,73	310-110-581	25
120	0,38	0,09	65	129	0,82	310-120-581	25
125	0,38	0,09	70	132	0,84	310-125-581	25
127	0,38	0,09	70	134	0,85	310-127-581	25
150	0,31	0,06	78	157	1,01	310-150-581	25
152	0,3	0,06	80	159	1,02	310-152-581	25
180	0,23	0,06	95	189	1,38	310-180-581	25
200	0,23	0,06	102	207	1,5	310-200-581	25
203	0,23	0,06	105	210	1,52	310-203-581	25
250	0,16	0,03	126	256	1,66	310-250-581	25
254	0,15	0,03	130	260	1,65	310-254-581	25
300	0,14	0,03	155	310	1,78	310-300-581	25
350	0,12	0,03	180	360	2,44	310-350-581	25
400	0,12	0,03	210	410	3,04	310-400-581	25

All data refers to a medium and ambient temperature of +20 °C. * Refers to the inner hose lining. Subject to technical changes and colour deviations

Master-PUR L Food

PU Suction & Transport Hose, light duty, highly flexible, food-grade quality acc. to EU 10/2011 and FDA

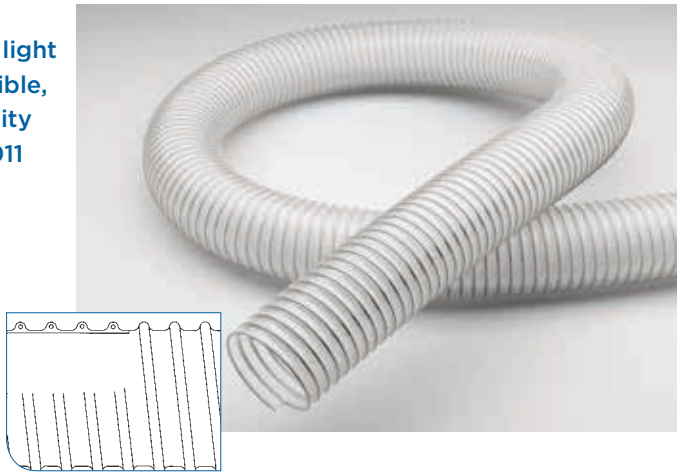

Connections:



Material

- spiral: spring steel wire (stainless steel 1.4310)
- wall: pure polyether polyurethane, food-grade quality (FDA)
- wall thickness between spirals approx. 0.7 mm

Applications

- Pharmaceutical industry
- Chemicals industry
- Food industry

Temperature Range

- -40°C to +90°C
- peaks to +125°C

Properties

- materials comply with the following food regulations:
 - FDA 21 CFR §177.2600
 - FDA 21 CFR §178.2010

- The hose conforms with EU Guideline 10/2011
- smallest bending radii
- optimum flow characteristics
- mostly smooth inner lining
- abrasion-resistant
- odourless/tasteless
- microbe and hydrolysis-resistant
- light
- very good flexibility
- halogen and plasticizer-free
- good chemical resistance
- high tensile strength
- generally good UV and ozone resistance
- Approved for food-grade categories: A, B, C, D1, D2, E (contact durations acc. to Test Report)
- acc. to TRGS 727 and ATEX 2014/34 EU, with earthing at both ends of the spiral for non-flammable dust/bulk solids in Zone 22. For gases/liquids with low conductivity of electrostatic charges in Zone 2.

DN	op. pressure bar	vacuum bar	bend radius mm	outer Ø mm	weight/m kg	article no.	max. production length m
32	2,52	0,71	40	40	0,35	110-032-501	25
38	2,1	0,66	46	46	0,39	110-038-501	25
40	2,1	0,66	48	48	0,4	110-040-501	25
50	1,71	0,51	57	57	0,45	110-050-501	25
51	1,68	0,52	58	58	0,45	110-051-501	25
60	1,4	0,44	68	68	0,53	110-060-501	25
65	1,26	0,37	75	73	0,64	110-065-501	25
70	1,12	0,37	80	78	0,68	110-070-501	25
75	1,12	0,3	84	83	0,71	110-075-501	25
76	1,12	0,29	85	84	0,72	110-076-501	25
80	0,98	0,29	90	88	0,76	110-080-501	25
100	0,84	0,22	108	108	0,94	110-100-501	25
102	0,84	0,22	110	110	0,95	110-102-501	25
110	0,7	0,22	119	119	1,23	110-110-501	25
120	0,7	0,22	130	129	1,12	110-120-501	25
125	0,7	0,22	133	133	1,17	110-125-501	25
127	0,7	0,22	135	135	1,18	110-127-501	25
130	0,56	0,22	141	140	1,2	110-130-501	25
150	0,56	0,15	163	159	1,47	110-150-501	25
152	0,56	0,15	165	161	1,48	110-152-501	25
160	0,56	0,15	170	170	1,74	110-160-501	25
180	0,42	0,15	190	190	1,9	110-180-501	25
200	0,42	0,15	212	211	2,25	110-200-501	25
203	0,42	0,15	215	214	2,3	110-203-501	25

All data refers to a medium and ambient temperature of +20 °C. * Refers to the inner hose lining. Subject to technical changes and colour deviations

Master-PUR L Food A

PU Suction & Transport Hose, light duty, highly flexible, food-grade quality acc. to EU 10/2011 and FDA, permanently antistatic

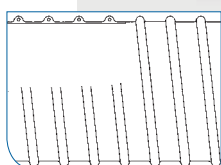
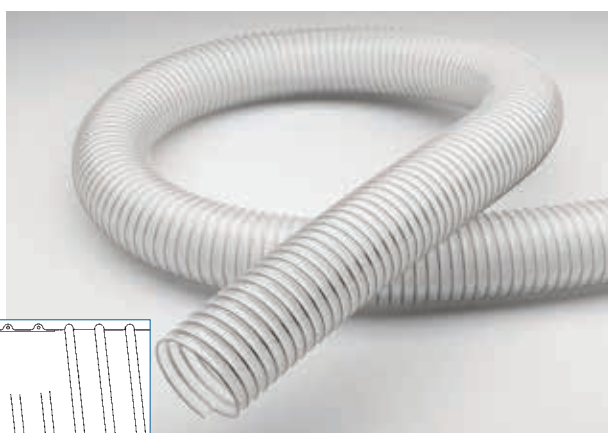

Connections:



Material

- spiral: spring steel wire (stainless steel 1.4310)
- wall: pure polyether polyurethane, food-grade (FDA), with non-migratory permanent antistatic agent
- wall thickness between spirals approx. 0.7 mm

Applications

- Pharmaceutical industry
- Chemicals industry
- Food industry

Temperature Range

- -40°C to +90°C
- peaks to +125°C

Properties

- EU guidelines EU 10/2011 and most recent amending directives
- Approved for food-grade category: E (contact duration acc. to Test Report)

- The material of the wall complies with the FDA Food regulations 21 CFR § 177.1680 and 21 CFR § 177.2600
- permanently antistatic, surface resistance < 10⁹ Ohm, measured acc. to DIN EN ISO 8031
- approved acc. to TRGS 727 and ATEX 2014/34 EU. Details acc. to certificate
- light-duty
- very good flexibility
- smallest bending radii
- abrasion-resistant
- optimum flow characteristics
- mostly smooth inner lining
- odourless/tasteless
- microbe and hydrolysis-resistant
- halogen and plasticizer-free
- good chemical resistance
- high tensile strength
- generally good UV and ozone resistance

DN	op. pressure bar	vacuum bar	bend radius mm	outer Ø mm	weight/m kg	article no.	max. production length m
32	2,52	0,71	40	40	0,35	110-032-581	25
38	2,1	0,66	46	46	0,39	110-038-581	25
40	2,1	0,66	48	48	0,4	110-040-581	25
50	1,71	0,53	57	57	0,45	110-050-581	25
51	1,68	0,52	58	58	0,45	110-051-581	25
60	1,4	0,44	68	68	0,53	110-060-581	25
65	1,26	0,37	75	73	0,64	110-065-581	25
70	1,12	0,37	80	78	0,68	110-070-581	25
75	1,12	0,3	84	83	0,71	110-075-581	25
76	1,12	0,29	85	84	0,72	110-076-581	25
80	0,98	0,29	90	88	0,76	110-080-581	25
100	0,84	0,22	108	108	0,94	110-100-581	25
102	0,84	0,22	110	110	0,95	110-102-581	25
110	0,7	0,22	119	119	1,23	110-110-581	25
120	0,7	0,22	130	129	1,12	110-120-581	25
125	0,7	0,22	133	133	1,16	110-125-581	25
127	0,7	0,22	135	135	1,18	110-127-581	25
130	0,56	0,22	141	140	1,23	110-130-581	25
150	0,56	0,15	163	159	1,57	110-150-581	25
152	0,56	0,15	165	161	1,6	110-152-581	25
160	0,56	0,15	170	170	1,74	110-160-581	25
180	0,42	0,15	190	190	1,9	110-180-581	25
200	0,42	0,15	212	212	2,25	110-200-581	25
203	0,42	0,15	215	214	2,3	110-203-581	25

All data refers to a medium and ambient temperature of +20 °C. * Refers to the inner hose lining. Subject to technical changes and colour deviations

Master-PUR L Food A Multi

PU Suction & Transport Hose, light duty, highly flexible, food-grade quality acc. to EU 10/2011 and FDA, permanently antistatic

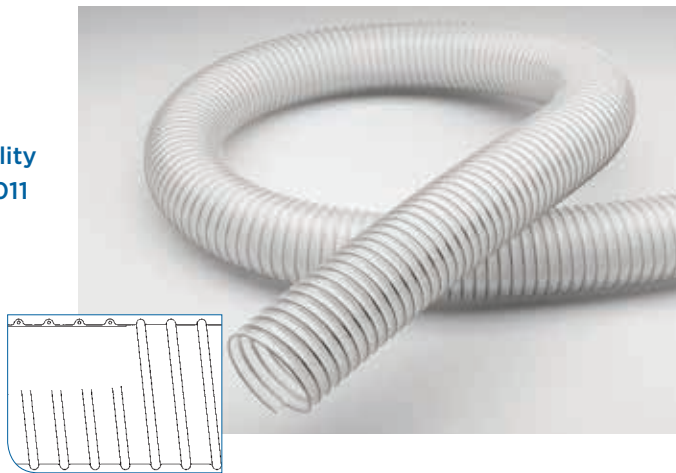

Connections:



Material

- spiral: spring steel wire (stainless steel 1.4310)
- wall: pure polyether polyurethane, food-grade (FDA), with non-migratory permanent antistatic agent
- wall thickness between spirals approx. 0.7 mm

Applications

- Pharmaceutical industry
- Chemicals industry
- Food industry

Temperature Range

- -40°C to +90°C
- peaks to +125°C

Properties

- approved acc. to TRGS 727 and ATEX 2014/34 EU
- permanently antistatic, surface resistance < 10⁹ Ohm

- The hose conforms with EU Guideline 10/2011
- smallest bending radii
- optimum flow characteristics
- mostly smooth inner lining
- abrasion-resistant
- odourless/tasteless
- microbe and hydrolysis-resistant
- light
- very good flexibility
- halogen and plasticizer-free
- gas-tight
- good chemical resistance
- high tensile strength
- generally good UV and ozone resistance
- The material of the wall complies with the FDA food regulations 21 CFR § 177.1680 and 21 CFR § 177.2600
- Approved for food-grade categories: A, B, C, D1, D2, E (contact durations acc. to Test Report)

DN	op. pressure bar	vacuum bar	bend radius mm	outer Ø mm	weight/m kg	article no.	max. production length m
32	2,52	0,71	40	40	0,35	110-032-571	25
38	2,1	0,66	46	46	0,39	110-038-571	25
40	2,1	0,66	48	48	0,4	110-040-571	25
50	1,71	0,53	57	57	0,45	110-050-571	25
51	1,68	0,52	58	58	0,45	110-051-571	25
60	1,4	0,44	68	68	0,53	110-060-571	25
65	1,26	0,37	75	73	0,64	110-065-571	25
70	1,12	0,37	80	78	0,68	110-070-571	25
75	1,12	0,3	84	83	0,71	110-075-571	25
76	1,12	0,29	85	84	0,72	110-076-571	25
80	0,98	0,29	90	88	0,76	110-080-571	25
100	0,84	0,22	108	108	0,94	110-100-571	25
102	0,84	0,22	110	110	0,95	110-102-571	25
110	0,7	0,22	119	119	1,23	110-110-571	25
120	0,7	0,22	130	129	1,12	110-120-571	25
125	0,7	0,22	133	133	1,16	110-125-571	25
127	0,7	0,22	135	135	1,18	110-127-571	25
130	0,56	0,22	141	140	1,23	110-130-571	25
150	0,56	0,15	163	159	1,57	110-150-571	25
152	0,56	0,15	165	161	1,6	110-152-571	25
160	0,56	0,15	170	170	1,74	110-160-571	25
180	0,42	0,15	190	190	1,9	110-180-571	25
200	0,42	0,15	212	212	2,25	110-200-571	25
203	0,42	0,15	215	214	2,3	110-203-571	25

All data refers to a medium and ambient temperature of +20 °C. * Refers to the inner hose lining. Subject to technical changes and colour deviations

Master-PUR H Food

PU Suction & Transport Hose, medium duty, very flexible, food-grade quality acc. to EU 10/2011 and FDA

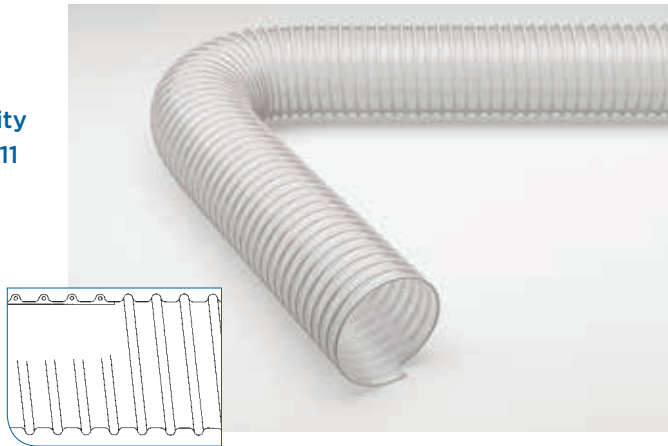

Connections:



Material

- spiral: spring steel wire (stainless steel 1.4310)
- wall: pure polyether polyurethane, food-grade quality (FDA)
- wall thickness between spirals approx. 1.4 mm

Applications

- Pharmaceutical industry
- Chemicals industry
- Food industry

Temperature Range

- -40°C to +90°C
- peaks to +125°C

Properties

- materials comply with the following food regulations:
 - FDA 21 CFR §177.2600
 - FDA 21 CFR §178.2010
- The hose conforms with EU Guideline 10/2011

- small bending radii
- optimum flow characteristics
- mostly smooth inner lining
- abrasion-resistant
- odourless/tasteless
- microbe and hydrolysis-resistant
- medium duty
- good flexibility
- halogen and plasticizer-free
- good chemical resistance
- increased pressure and vacuum resistance
- high tensile strength
- Approved for food-grade categories: A, B, C, D1, D2, E (contact durations acc. to Test Report).
- generally good UV and ozone resistance
- acc. to TRGS 727 and ATEX 2014/34 EU, with earthing at both ends of the spiral for non-flammable dust/bulk solids in Zone 22. For gases/liquids with low conductivity of electrostatic charges in Zone 2.

DN	op. pressure bar	vacuum bar	bend radius mm	outer Ø mm	weight/m kg	article no.	max. production length m
20	4,3	0,92	45	28	0,23	111-020-501	25
25	4,16	0,92	50	33	0,3	111-025-501	25
30	3,51	0,92	56	39	0,37	111-030-501	25
32	3,25	0,92	60	41	0,39	111-032-501	25
38	3,12	0,82	70	47	0,46	111-038-501	25
40	3	0,82	70	49	0,49	111-040-501	25
50	2,9	0,8	86	60	0,68	111-050-501	25
51	2,9	0,79	87	61	0,71	111-051-501	25
60	2,55	0,74	105	70	0,84	111-060-501	25
65	2,4	0,66	115	75	0,91	111-065-501	25
70	2,25	0,66	120	80	0,97	111-070-501	25
75	2	0,6	124	86	1,05	111-075-501	25
76	2	0,59	125	87	1,06	111-076-501	25
80	2	0,59	135	91	1,11	111-080-501	25
100	1,5	0,45	163	110	1,44	111-100-501	25
102	1,5	0,44	165	112	1,48	111-102-501	25
120	1,3	0,31	195	131	1,75	111-120-501	25
125	1,3	0,31	203	136	1,86	111-125-501	25
127	1,3	0,31	205	138	1,91	111-127-501	25
130	1,3	0,31	209	141	1,96	111-130-501	25
150	1,05	0,25	243	161	2,26	111-150-501	25
152	1,05	0,25	245	163	2,29	111-152-501	25
170	0,9	0,18	255	181	2,67	111-170-501	25
200	0,75	0,18	320	212	3,41	111-200-501	25

All data refers to a medium and ambient temperature of +20 °C. * Refers to the inner hose lining. Subject to technical changes and colour deviations

Sample applications: Production of bakery products



Nowadays, many baked goods are produced in large-scale bakeries. As such, stringent legal requirements must be adhered to, and hygienic standards complied with, in order to ensure impeccable product quality.

Hoses are used at many points in an industrial bakery's chain of production. During goods delivery, for example, pulverised media such as flour or baking powder are conveyed from lorries to their corresponding silos and storage tanks. Food-grade Masterflex hoses, such as the **Master-PUR HX Food** or the **Polderflex PUR Food**, for example, are used in such instances. Positive or vacuum pressure is used to transport powder to the silos by means of pneumatic delivery. Signs of wear are not uncommon at this juncture, as high levels of abrasion can occur as a result of particle impact on the hose wall. Masterflex's highly abrasion-resistant food hoses are especially designed suited for these demanding tasks; their robust outer walls, made from polyether polyurethane, offer long endurance and effective wear resistance.

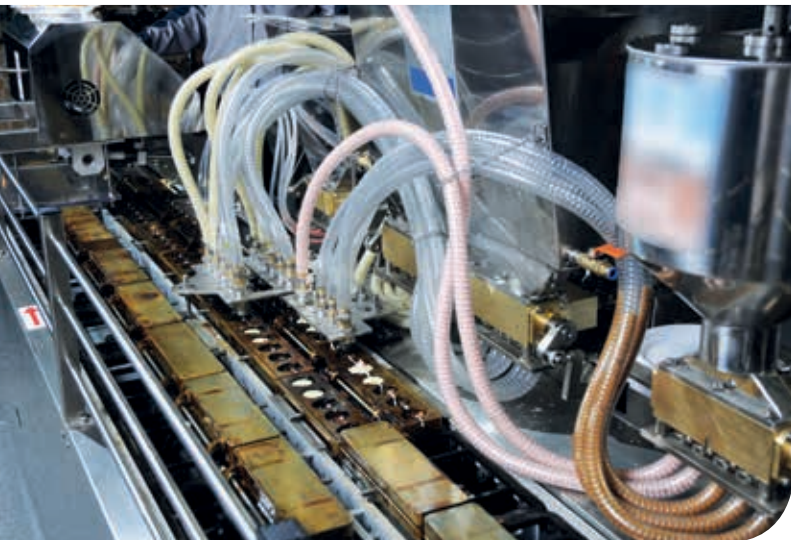

Masterflex hoses are also employed at subsequent stages of the production process: over short-distance connections such as links from pipelines to distributing stations, for example, at connections between dough mixers and VA piping, at vibrating sieves, or for extraction of warm air during the baking process.

In addition to the impact wear already mentioned, which results from abrasion, other factors such as heavy mechanical strain, moisture and heat can also affect the hose material in these kinds of applications. Depending on requirements, hoses such as the **Master-PUR Flat Food** offer significant flexibility for use with vibrating sieves, for example. In addition, all hoses are microbe and hydrolysis-resistant, so that they cannot be damaged by moisture.



Heated feed lines are also used frequently. We highly recommend the use of **templine®** heated hoses for this purpose (see page 38).

Master-PUR H Food A

PU Suciton & Transport Hose, medium duty, very flexible, food-grade quality acc. to EU 10/2011 and FDA, permanently antistatic

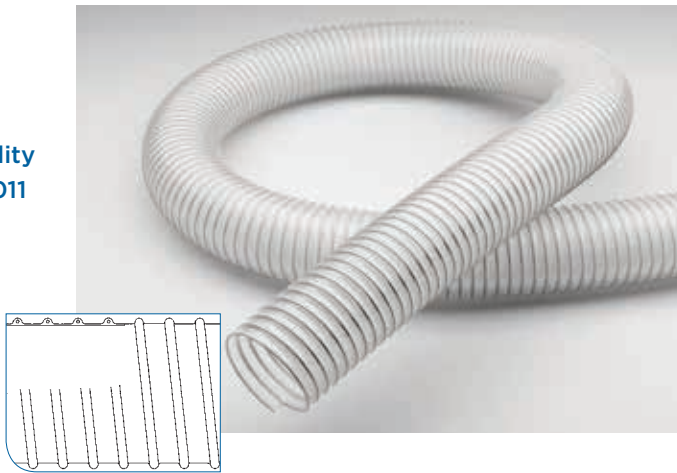

Connections:



Material

- spiral: spring steel wire (stainless steel 1.4310)
- wall: pure polyether polyurethane, food-grade (FDA), with non-migratory permanent antistatic agent
- wall thickness between spirals approx. 1.4 mm

Applications

- Pharmaceutical industry
- Chemicals industry
- Food industry

Temperature Range

- -40°C to +90°C
- peaks to +125°C

Properties

- approved acc. to TRGS 727 and ATEX 2014/34 EU. Details acc. to certificate

- permanently antistatic, surface resistance <math>< 10^9 \text{ Ohm}</math>
- The hose conforms with EU Guideline 10/2011
- small bending radii
- optimum flow characteristics
- mostly smooth inner lining
- abrasion-resistant
- odourless/tasteless
- microbe and hydrolysis-resistant
- medium duty
- good flexibility
- halogen and plasticizer-free
- good chemical resistance
- high tensile strength
- generally good UV and ozone resistance
- The material of the wall complies with the FDA food regulations 21 CFR § 177.1680 and 21 CFR § 177.2600
- Approved for food-grade category: E (contact duration acc. to Test Report)

DN	op. pressure bar	vacuum bar	bend radius mm	outer Ø mm	weight/m kg	article no.	max. production length m
20	4,3	0,92	45	28	0,23	111-020-581	25
25	4,16	0,92	50	33	0,3	111-025-581	25
30	3,51	0,92	56	39	0,37	111-030-581	25
32	3,25	0,92	60	41	0,39	111-032-581	25
38	3,12	0,82	70	47	0,46	111-038-581	25
40	3	0,82	70	49	0,49	111-040-581	25
50	2,9	0,8	86	60	0,68	111-050-581	25
51	2,9	0,79	87	61	0,71	111-051-581	25
60	2,55	0,74	105	70	0,84	111-060-581	25
65	2,4	0,66	115	75	0,91	111-065-581	25
70	2,25	0,66	120	80	0,97	111-070-581	25
75	2	0,6	124	86	1,05	111-075-581	25
76	2	0,59	125	87	1,06	111-076-581	25
80	2	0,59	135	91	1,11	111-080-581	25
100	1,5	0,45	163	110	1,44	111-100-581	25
102	1,5	0,44	165	112	1,48	111-102-581	25
120	1,3	0,31	195	131	1,75	111-120-581	25
125	1,3	0,31	203	136	1,86	111-125-581	25
127	1,3	0,31	205	138	1,91	111-127-581	25
130	1,3	0,31	209	141	1,96	111-130-581	25
150	1,05	0,25	243	161	2,26	111-150-581	25
152	1,05	0,25	245	163	2,29	111-152-581	25
170	0,9	0,18	255	181	2,67	111-170-581	25
200	0,75	0,18	320	212	3,41	111-200-581	25

All data refers to a medium and ambient temperature of +20 °C. * Refers to the inner hose lining. Subject to technical changes and colour deviations

Master-PUR H Food A Multi

PU Suciton & Transport Hose, medium duty, very flexible, food-grade quality acc. to EU 10/2011 and FDA, permanently antistatic

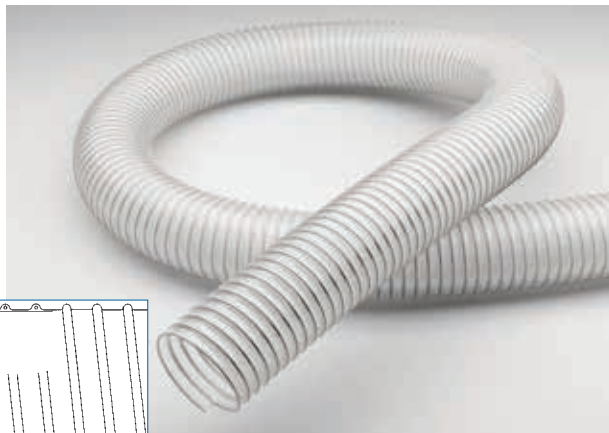
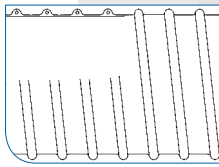

Connections:



Material

- spiral: spring steel wire (stainless steel 1.4310)
- wall: pure polyether polyurethane, food-grade (FDA), with non-migratory permanent antistatic agent
- wall thickness between spirals approx. 1.4 mm

Applications

- Pharmaceutical industry
- Chemicals industry
- Food industry

Temperature Range

- -40°C to +90°C
- peaks to +125°C

Properties

- approved acc. to TRGS 727 and ATEX 2014/34 EU
- permanently antistatic, surface resistance < 10⁹ Ohm

- The hose conforms with EU Guideline 10/2011
- small bending radii
- optimum flow characteristics
- mostly smooth inner lining
- abrasion-resistant
- odourless/tasteless
- microbe and hydrolysis-resistant
- medium duty
- good flexibility
- halogen and plasticizer-free
- good chemical resistance
- high tensile strength
- generally good UV and ozone resistance
- The material of the wall complies with the FDA food regulations 21 CFR § 177.1680 and 21 CFR § 177.2600
- Approved for food-grade categories: A, B, C, D1, D2, E (contact durations acc. to Test Report)

DN	op. pressure bar	vacuum bar	bend radius mm	outer Ø mm	weight/m kg	article no.	max. production length m
20	4,3	0,92	45	28	0,23	111-020-571	25
25	4,16	0,92	50	33	0,3	111-025-571	25
30	3,51	0,92	56	39	0,37	111-030-571	25
32	3,25	0,92	60	41	0,39	111-032-571	25
38	3,12	0,82	70	47	0,46	111-038-571	25
40	3	0,82	70	49	0,49	111-040-571	25
50	2,9	0,8	86	60	0,68	111-050-571	25
51	2,9	0,79	87	61	0,71	111-051-571	25
60	2,55	0,74	105	70	0,84	111-060-571	25
65	2,4	0,66	115	75	0,91	111-065-571	25
70	2,25	0,66	120	80	0,97	111-070-571	25
75	2	0,6	124	86	1,05	111-075-571	25
76	2	0,59	125	87	1,06	111-076-571	25
80	2	0,59	135	91	1,11	111-080-571	25
100	1,5	0,45	163	110	1,44	111-100-571	25
102	1,5	0,44	165	112	1,48	111-102-571	25
120	1,3	0,31	195	131	1,75	111-120-571	25
125	1,3	0,31	203	136	1,86	111-125-571	25
127	1,3	0,31	205	138	1,91	111-127-571	25
130	1,3	0,31	209	141	1,96	111-130-571	25
150	1,05	0,25	243	161	2,26	111-150-571	25
152	1,05	0,25	245	163	2,29	111-152-571	25
170	0,9	0,18	255	181	2,67	111-170-571	25
200	0,75	0,18	320	212	3,41	111-200-571	25

All data refers to a medium and ambient temperature of +20 °C. * Refers to the inner hose lining. Subject to technical changes and colour deviations

Master-PUR HX Food

PU Suction & Transport Hose, heavy-duty, food-grade quality acc. to EU 10/2011 and FDA

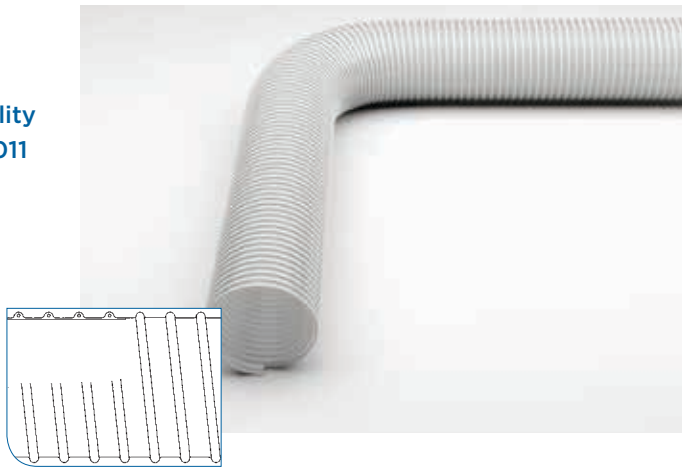

Connections:



Material

- spiral: spring steel wire (stainless steel 1.4310)
- wall: pure polyether polyurethane, food-grade quality (FDA)
- wall thickness between spirals approx. 1.7 - 2.1 mm, depending on DN

Applications

- Pharmaceutical industry
- Chemicals industry
- Food industry

Temperature Range

- -40°C to +90°C
- peaks to +125°C

Properties

- heavy-duty
- extremely abrasion resistant via specific reinforcements underneath the spiral

- materials comply with the following food regulations:
 - FDA 21 CFR §177.2600
 - FDA 21 CFR §178.2010
- The hose conforms with EU Guideline 10/2011
- optimum flow characteristics
- mostly smooth inner lining
- odourless/tasteless
- microbe and hydrolysis-resistant
- flexible
- halogen and plasticizer-free
- good chemical resistance
- increased pressure and vacuum resistance
- high tensile strength
- Approved for food-grade categories: A, B, C, D1, D2, E (contact durations acc. to Test Report)
- generally good UV and ozone resistance
- acc. to TRGS 727 and ATEX 2014/34 EU, with earthing at both ends of the spiral for non-flammable dust/bulk solids in Zone 22. For gases/liquids with low conductivity of electrostatic charges in Zone 2.

DN	op. pressure bar	vacuum bar	bend radius mm	outer Ø mm	weight/m kg	article no.	max. production length m
32	4,85	0,94	80	42	0,66	114-032-501	20
40	4,27	0,94	100	50	0,83	114-040-501	20
50	4,02	0,94	123	60	1,02	114-050-501	20
51	4	0,94	125	61	1,04	114-051-501	20
55	3,75	0,89	140	65	1,1	114-055-501	20
60	3,6	0,89	150	70	1,2	114-060-501	20
65	3,3	0,89	165	75	1,29	114-065-501	20
70	3,15	0,89	175	80	1,38	114-070-501	20
75	2,96	0,89	188	86	1,57	114-075-501	20
76	2,92	0,89	190	87	1,61	114-076-501	20
80	2,77	0,89	200	93	1,93	114-080-501	20
90	2,4	0,89	225	103	2,16	114-090-501	20
100	2,15	0,87	246	113	2,53	114-100-501	20
102	2,1	0,87	250	115	2,6	114-102-501	20
110	1,95	0,87	275	124	2,82	114-110-501	20
115	1,8	0,87	290	129	2,94	114-115-501	20
120	1,65	0,87	300	134	3,07	114-120-501	20
125	1,65	0,87	310	138	3,33	114-125-501	20
127	1,65	0,87	315	140	3,44	114-127-501	20
130	1,65	0,84	325	145	3,54	114-130-501	20
140	1,5	0,83	350	153	3,81	114-140-501	20
150	1,5	0,82	433	165	4,08	114-150-501	20
152	1,5	0,82	450	167	4,13	114-152-501	20

All data refers to a medium and ambient temperature of +20 °C. * Refers to the inner hose lining. Subject to technical changes and colour deviations

Master-PUR HX Food A

PU suction & Transport Hose, heavy-duty, food-grade quality acc. to EU 10/2011 and FDA, permanently antistatic

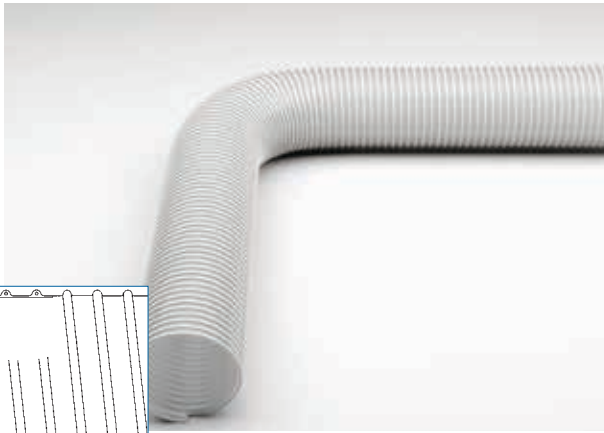

Connections



Material

- spiral: spring steel wire (stainless steel 1.4310)
- wall: pure polyether polyurethane, food-grade (FDA), with non-migratory permanent antistatic agent
- wall thickness between spirals approx. 1.7 - 2.1 mm, depending on DN

Applications

- Pharmaceutical industry
- Chemicals industry
- Food industry

Temperature Range

- -40°C to +90°C
- peaks to +125°C

Properties

- approved acc. to TRGS 727 and ATEX 2014/34 EU
- heavy-duty
- permanently antistatic, surface resistance < 10⁹ Ohm

- extremely abrasion resistant via specific reinforcements underneath the spiral
- The hose conforms with EU Guideline 10/2011
- optimum flow characteristics
- mostly smooth inner lining
- odourless/tasteless
- microbe and hydrolysis-resistant
- flexible
- halogen and plasticizer-free
- good chemical resistance
- increased pressure and vacuum resistance
- high tensile strength
- generally good UV and ozone resistance
- The material of the wall complies with the FDA food regulations 21 CFR § 177.1680 and 21 CFR § 177.2600
- Approved for food-grade category: E (contact duration acc. to Test Report)

DN	op. pressure bar	vacuum bar	bend radius mm	outer Ø mm	weight/m kg	article no.	max. production length m
32	4,85	0,94	80	42	0,66	114-032-581	20
40	4,27	0,94	100	50	0,83	114-040-581	20
50	4,02	0,94	123	60	1,02	114-050-581	20
51	4	0,94	125	61	1,04	114-051-581	20
55	3,75	0,89	140	65	1,1	114-055-581	20
60	3,6	0,89	150	70	1,2	114-060-581	20
65	3,3	0,89	165	75	1,29	114-065-581	20
70	3,15	0,89	175	80	1,38	114-070-581	20
75	2,96	0,89	188	86	1,57	114-075-581	20
76	2,92	0,89	190	87	1,61	114-076-581	20
80	2,77	0,89	200	93	1,93	114-080-581	20
90	2,4	0,89	225	103	2,16	114-090-581	20
100	2,15	0,87	246	113	2,53	114-100-581	20
102	2,1	0,87	250	115	2,6	114-102-581	20
110	1,95	0,87	275	124	2,82	114-110-581	20
115	1,8	0,87	290	129	2,94	114-115-581	20
120	1,65	0,87	300	134	3,07	114-120-581	20
125	1,65	0,87	310	138	3,33	114-125-581	20
127	1,65	0,87	315	140	3,44	114-127-581	20
130	1,65	0,84	325	145	3,54	114-130-581	20
140	1,5	0,83	350	153	3,81	114-140-581	20
150	1,5	0,82	433	165	4,08	114-150-581	20
152	1,5	0,82	450	167	4,13	114-152-581	20

All data refers to a medium and ambient temperature of +20 °C. * Refers to the inner hose lining. Subject to technical changes and colour deviations

Master-PUR HX Food A Multi

PU suction & Transport Hose, heavy-duty, food-grade quality acc. to EU 10/2011 and FDA, permanently antistatic

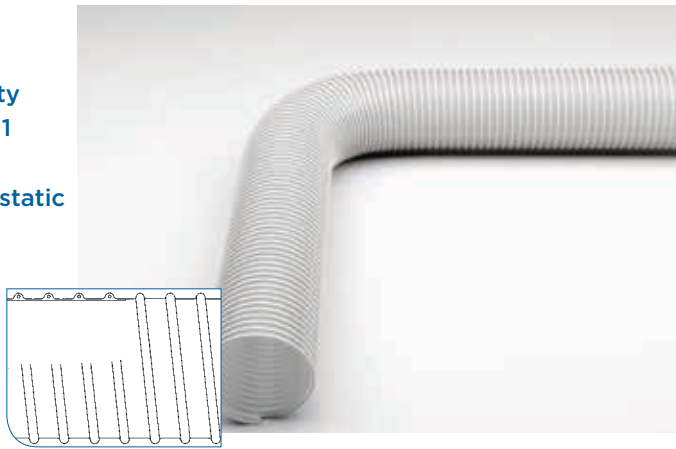

Connections



Material

- spiral: spring steel wire (stainless steel 1.4310)
- wall: pure polyether polyurethane, food-grade (FDA), with non-migratory permanent antistatic agent
- wall thickness between spirals approx. 1.7 - 2.1 mm, depending on DN

Applications

- Pharmaceutical industry
- Chemicals industry
- Food industry

Temperature Range

- -40°C to +90°C
- peaks to +125°C

Properties

- approved acc. to TRGS 727 and ATEX 2014/34 EU. Details acc. to certificate
- heavy-duty
- permanently antistatic, surface resistance < 10⁹ Ohm

- extremely abrasion resistant via specific reinforcements underneath the spiral
- The hose conforms with EU Guideline 10/2011
- optimum flow characteristics
- mostly smooth inner lining
- odourless/tasteless
- microbe and hydrolysis-resistant
- flexible
- halogen and plasticizer-free
- good chemical resistance
- increased pressure and vacuum resistance
- high tensile strength
- generally good UV and ozone resistance
- The material of the wall complies with the FDA food regulations 21 CFR § 177.1680 and 21 CFR § 177.2600
- Approved for food-grade categories: A, B, C, D1, D2, E (contact durations acc. to Test Report)

DN	op. pressure bar	vacuum bar	bend radius mm	outer Ø mm	weight/m kg	article no.	max. production length m
32	4,85	0,94	80	42	0,66	114-032-571	20
40	4,27	0,94	100	50	0,83	114-040-571	20
50	4,02	0,94	123	60	1,02	114-050-571	20
51	4	0,94	125	61	1,04	114-051-571	20
55	3,75	0,89	140	65	1,1	114-055-571	20
60	3,6	0,89	150	70	1,2	114-060-571	20
65	3,3	0,89	165	75	1,29	114-065-571	20
70	3,15	0,89	175	80	1,38	114-070-571	20
75	2,96	0,89	188	86	1,57	114-075-571	20
76	2,92	0,89	190	87	1,61	114-076-571	20
80	2,77	0,89	200	93	1,93	114-080-571	20
90	2,4	0,89	225	103	2,16	114-090-571	20
100	2,15	0,87	246	113	2,53	114-100-571	20
102	2,1	0,87	250	115	2,6	114-102-571	20
110	1,95	0,87	275	124	2,82	114-110-571	20
115	1,8	0,87	290	129	2,94	114-115-571	20
120	1,65	0,87	300	134	3,07	114-120-571	20
125	1,65	0,87	310	138	3,33	114-125-571	20
127	1,65	0,87	315	140	3,44	114-127-571	20
130	1,65	0,84	325	145	3,54	114-130-571	20
140	1,5	0,83	350	153	3,81	114-140-571	20
150	1,5	0,82	433	165	4,08	114-150-571	20
152	1,5	0,82	450	167	4,13	114-152-571	20

All data refers to a medium and ambient temperature of +20 °C. * Refers to the inner hose lining. Subject to technical changes and colour deviations

Polderflex PUR Food

PU Suction & Transport Hose, extremely pressure/vacuum-proof, smooth inner and outer linings, food-grade quality acc. to EU 10/2011 and FDA

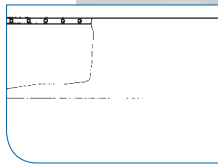

Connections



Hose Clamp with Bolts

Material

- spiral: spring steel wire (stainless steel 1.4310)
- wall: pure polyether polyurethane, food-grade quality (FDA)
- wall thickness 3-5 mm depending on DN

Applications

- Pharmaceutical industry
- Chemicals industry
- Food industry

Temperature Range

- -40°C to +90°C
- peaks to +125°C

Properties

- Extra Heavyweight
- materials comply with the following food regulations:
 - FDA 21 CFR §177.2600
 - FDA 21 CFR §178.2010

- The hose conforms with EU Guideline 10/2011
- optimum flow characteristics
- highly abrasion-resistant
- odourless/tasteless
- microbe and hydrolysis-resistant
- flexible
- halogen and plasticizer-free
- smooth inner and outer linings
- good chemical resistance
- increased pressure and vacuum resistance
- high tensile strength
- generally good UV and ozone resistance
- Approved for food-grade categories: A, B, C, D1, D2, E (contact durations acc. to Test Report)
- acc. to TRGS 727 and ATEX 2014/34 EU, with earthing at both ends of the spiral for non-flammable dust/bulk solids in Zone 22. For gases/liquids with low conductivity of electrostatic charges in Zone 2.

DN	op. pressure bar	vacuum bar	bend radius mm	outer Ø mm	weight/m kg	article no.	max. production length m
32	5,75	0,93	160	41,5	0,88	118-032-501	20
38	5,625	0,93	190	47,5	1,03	118-038-501	20
40	5,5	0,93	200	49,5	1,07	118-040-501	20
50	5,27	0,93	245	61,5	1,23	118-050-501	20
51	5,25	0,93	250	62,5	1,25	118-051-501	20
60	5,125	0,93	300	71,5	1,44	118-060-501	20
65	5,1	0,93	325	76,5	1,56	118-065-501	20
70	5,05	0,93	350	81,5	1,77	118-070-501	20
75	5,01	0,93	375	86,5	1,9	118-075-501	20
76	5	0,93	380	87,5	1,92	118-076-501	20
80	4,5	0,88	400	91,5	2,01	118-080-501	20
100	4,16	0,86	580	111	3	118-100-501	20
102	4,125	0,86	600	113	3,1	118-102-501	20
125	3,32	0,66	692	136	3,79	118-125-501	20
127	3,25	0,64	700	138,5	3,85	118-127-501	20
150	2,22	0,44	792	162	4,53	118-150-501	20
152	2,125	0,42	800	164	4,59	118-152-501	20

All data refers to a medium and ambient temperature of +20 °C. * Refers to the inner hose lining. Subject to technical changes and colour deviations



A variety of methods are used to manufacture sweets, fruit gums and liquorice confectionery. However, the underlying principle is always the same: water, sugar and syrup are mixed together and brought to a suitable processing temperature. Acids, flavourings and colourants are then added until the end product results from the viscous mixture.

The various ingredients pass through a range of stages within the chain of production, up to the ready-to-eat end product. Powder and dust, as well as liquid substances such as rubber mass and syrup, for example, are conveyed and processed as part of this process. The rubber mass is heated in boilers and conveyed to mixing drums. Feed lines often consist of VA steel pipes, which are equipped with hoses via connectors to the mixing drums. Hoses offer an advantage over pipes in that they can be laid easily in confined installation conditions with small bending radii. Wear-resistant hoses, and even heated hoses and connecting elements such as the **Master-PUR H Food**, or the **Polderflex PUR Food** or **templiner®** heated hoses, for example, are used in this way. The transparent outer wall provides a view of the conveyed medium at all times. Compatible connecting elements, such as fixed flanges with dairy pipe screw connections, ensure a secure connection and also facilitate rapid disconnection for cleaning or repair of hose connections.

Sugar and flavouring are conveyed to the mixing vessel further along in the process. Masterflex food hoses provide significant benefits with regard to such materials, due to their abrasion-resistant properties. Various acids also have an effect on hose material during supply of syrup or flavour enhancers. However, due to the raw material composition of **Master-PUR Food** hoses, long service life can be achieved even under such conditions.



Polderflex PUR Food A

PU Suction & Transport Hose, extremely pressure/vacuum-proof, smooth inner and outer linings, permanently antistatic, food-grade quality acc. to EU 10/2011 and FDA



Connections



Hose Clamp with Bolts

Material

- spiral: spring steel wire (stainless steel 1.4310)
- wall: pure polyether polyurethane, food-grade (FDA), with non-migratory permanent antistatic agent
- wall thickness 3-5 mm depending on DN

Applications

- Pharmaceutical industry
- Chemicals industry
- Food industry

Temperature Range

- -40°C to +90°C
- peaks to +125°C

Properties

- Extra Heavyweight
- approved acc. to TRGS 727 and ATEX 2014/34 EU. Details acc. to certificate
- surface resistance < 10⁹ Ohm
- The hose conforms with EU Guideline 10/2011

- optimum flow characteristics
- highly abrasion-resistant
- odourless/tasteless
- microbe and hydrolysis-resistant
- flexible
- halogen and plasticizer-free
- good chemical resistance
- increased pressure and vacuum resistance
- high tensile strength
- generally good UV and ozone resistance
- The material of the wall complies with the FDA food regulations 21 CFR § 177.1680 and 21 CFR § 177.2600
- Approved for food-grade category: E (contact duration acc. to Test Report)

DN	op. pressure bar	vacuum bar	bend radius mm	outer Ø mm	weight/m kg	article no.	max. production length m
32	5,75	0,93	160	41,5	0,88	118-032-581	20
38	5,625	0,93	190	47,5	1,03	118-038-581	20
40	5,5	0,93	200	49,5	1,07	118-040-581	20
50	5,27	0,93	245	61	1,23	118-050-581	20
51	5,25	0,93	250	62,5	1,25	118-051-581	20
60	5,125	0,93	300	71,5	1,44	118-060-581	20
65	5,1	0,93	325	76,5	1,56	118-065-581	20
70	5,05	0,93	350	81,5	1,77	118-070-581	20
75	5	0,93	377	87	1,91	118-075-581	20
76	5	0,93	380	87,5	1,92	118-076-581	20
80	4,5	0,88	400	91,5	2,01	118-080-581	20
100	4,15	0,86	580	111	3	118-100-581	20
102	4,125	0,86	600	113	3,1	118-102-581	20
125	3,32	0,66	690	136	3,79	118-125-581	20
127	3,25	0,64	700	138,5	3,85	118-127-581	20
150	2,22	0,44	790	162	4,53	118-150-581	20
152	2,125	0,42	800	164	4,59	118-152-581	20

All data refers to a medium and ambient temperature of +20 °C. * Refers to the inner hose lining. Subject to technical changes and colour deviations

Polderflex PUR Food A Multi

PU Suction & Transport Hose, extremely pressure/vacuum-proof, smooth inner & outer linings, permanent antistatic, Food-grade quality (FDA/ EU 10/2011)



Connections



Hose Clamp with Bolts

Material

- spiral: spring steel wire (stainless steel 1.4310)
- Wall: pure polyether polyurethane, food-grade (FDA/ EU10/2011) with non-migratory permanent antistatic agent
- Wall thickness 3 - 5 mm, depending on DN

Applications

- Food industry
- Pharmaceutical industry
- Chemicals industry

Temperature Range

- -40°C to +90°C
- peaks to +125°C

Properties

- The hose conforms to EU Guideline 10/2011
- Approved for food grade categories: A, B, C, D1, D2, E (contact durations acc. to Test Report)

- Surface resistance < 10⁹ Ohm, ρ < 2.5 x < 10⁸ Ohm
- The material of the hose wall conforms to the following food regulations: FDA 21 CFR §177.1680 and 21 CFR §177.2600
- Approved acc. to TRGS 727 and ATEX 2014/34 EU
- Super heavy
- Flexible
- Optimum flow characteristics
- Highly abrasion-resistant
- Odourless/tasteless
- Microbe and hydrolysis-resistant
- Halogen and plasticizer-free
- Good chemical resistance
- Increased pressure and vacuum resistance
- High tensile strength
- Generally good UV and ozone resistance

DN	op. pressure bar	vacuum bar	bend radius mm	outer Ø mm	weight/m kg	article no.	max. production length m
32	5,75	0,93	160	41,5	0,88	118-032-571	20
38	5,625	0,93	190	47,5	1,03	118-038-571	20
40	5,5	0,93	200	49,5	1,07	118-040-571	20
50	5,27	0,93	245	61	1,23	118-050-571	20
51	5,25	0,93	250	62,5	1,25	118-051-571	20
60	5,125	0,93	300	71,5	1,44	118-060-571	20
65	5,1	0,93	325	76,5	1,56	118-065-571	20
70	5,05	0,93	350	81,5	1,77	118-070-571	20
75	5	0,93	377	87	1,91	118-075-571	20
76	5	0,93	380	87,5	1,92	118-076-571	20
80	4,5	0,88	400	91,5	2,01	118-080-571	20
100	4,15	0,86	580	111	3	118-100-571	20
102	4,125	0,86	600	113	3,1	118-102-571	20
125	3,32	0,66	690	136	3,79	118-125-571	20
127	3,25	0,64	700	138,5	3,85	118-127-571	20
150	2,22	0,44	790	162	4,53	118-150-571	20
152	2,125	0,42	800	164	4,59	118-152-571	20

All data refers to a medium and ambient temperature of +20 °C. * Refers to the inner hose lining. Subject to technical changes and colour deviations

Master-PUR Flat H Food

Spiral-Free PU

Transport Hose,
medium duty, food-
grade quality acc.
to EU 10/2011 and
FDA



Connections



Hose Clamp with
Bolts

Hose Clamp with
Worm-Gear

TIP:
Also available
in L and HX
versions

Material

- wall: pure polyether polyurethane, food-grade quality (FDA)
- wall thickness approx. 1.5 mm

Applications

- Application as compensator
- Spiral-free transport hose for abrasive solids
- Solids transport for sieving machines
- Conductor hose on charging station
- Pharmaceutical industry
- Chemicals industry
- Food industry

Temperature Range

- -40°C to +90°C
- peaks to +125°C

Properties

- extremely vibration resistant
- materials comply with the following food regulations:
 - FDA 21 CFR §177.2600
 - FDA 21 CFR §178.2010
- The hose conforms with EU Guideline 10/2011
- solvent, oil and petroleum resistant
- optimum flow characteristics
- abrasion-resistant
- smooth inner lining
- permanently kink resistant
- high tensile strength
- generally good UV and ozone resistance
- Approved for food-grade categories: A, B, C, D1, D2, E (contact durations acc. to Test Report)

DN	weight/m kg	article no.	max. production length m
50	0,32	314-050-501	5
51	0,32	314-051-501	5
60	0,38	314-060-501	5
65	0,4	314-065-501	5
75	0,46	314-075-501	5
76	0,46	314-076-501	5
80	0,49	314-080-501	5
100	0,61	314-100-501	5
102	0,62	314-102-501	5
110	0,67	314-110-501	5
120	0,73	314-120-501	5
125	0,75	314-125-501	5
127	0,76	314-127-501	5
130	0,78	314-130-501	5
140	0,85	314-140-501	5
150	0,9	314-150-501	5
152	0,91	314-152-501	5
170	1,03	314-170-501	5
175	1,06	314-175-501	5
200	1,19	314-200-501	5
203	1,21	314-203-501	5
250	1,49	314-250-501	5
254	1,51	314-254-501	5
275	1,66	314-275-501	5
300	1,81	314-300-501	5

All data refers to a medium and ambient temperature of +20 °C. * Refers to the inner hose lining. Subject to technical changes and colour deviations

Master-SIL SD Food

Silicone Pressure Hose, Food-grade Quality (FDA)



Connections



Hose Clamp with Bolts

Material

- spiral: spring steel wire (stainless steel 1.4310)
- wall: multi-layered polyester fabric coated with transparent silicone, outer lining white, food-grade (FDA)
- Wall thickness c. 5.0 mm

Applications

- When using the corresponding connectors, the hose can remain in the pipeline for cleaning purposes
- Suction and transport hose for powder and liquid media in the food industry
- Machine development for cosmetic products
- Pharmaceutical industry
- Chemicals industry
- Food industry

Temperature Range

- -60°C to +200°C

Properties

- small bending radii
- optimum flow characteristics
- odourless/tasteless
- flexible
- smooth inner and outer linings
- Food-grade conformal acc. to BfR and FDA standards and therefore fully suitable for applications in food industry
- steam resistant
- good chemical resistance
- high pressure resistance

DN	op. pressure bar	vacuum bar	bend radius mm	outer Ø mm	weight/m kg	article no.	max. production length m
10	12	0,88	30	20	0,39	684-010-401	20
13	11	0,88	40	23	0,42	684-013-401	20
16	10	0,88	45	26	0,5	684-016-401	20
19	10	0,88	55	29	0,57	684-019-401	20
25	9	0,88	65	35	0,71	684-025-401	20
32	8	0,88	95	42	0,87	684-032-401	20
38	7	0,88	110	48	1,1	684-038-401	20
51	6	0,88	150	60	1,37	684-051-401	20
65	5	0,88	180	75	1,8	684-065-401	20
76	4	0,88	240	87	2,15	684-076-401	20
102	2,5	0,88	360	112	3,1	684-102-401	20

All data refers to a medium and ambient temperature of +20 °C. * Refers to the inner hose lining. Subject to technical changes and colour deviations

Master-Grip Double Wire Clamp, screw-fitting

Special clamp with double-wire system, stainless steel, for right-winding hoses/ducting



Material

- stainless steel 1..4301

Applications

- Special clamp for attaching light and medium-weight, right-winding spiral hoses/ducting such as Flamex B se, Flamex B-F se, Master-PUR Trivolution, Master-PUR Food, Master-PVC and Master-SANTO

Properties

- easy to install
- robust
- high sealing force
- extra tight connection via special double-wire system

Article No.	Clamping range in mm	Inventory item
624-025-888	31 - 37	Yes
624-030-888	38 - 46	Yes
624-051-888	51 - 61	Yes
624-063-888	63 - 73	Yes
624-070-888	77 - 86	Yes
624-075-888	83 - 96	Yes
624-090-888	90 - 110	Yes
624-102-888	101 - 121	Yes
624-120-888	119 - 135	Yes
624-140-888	146 - 160	Yes
624-152-888	154 - 170	Yes
624-170-888	167 - 182	Yes
624-203-888	197 - 217	Yes
624-225-888	220 - 240	Yes
624-254-888	246 - 266	Yes

All data refers to a medium and ambient temperature of +20 °C. Refers to the inner hose lining. Subject to technical changes and colour deviations.

Quick-Fix Clamp for Cone Flanges

in acc. with
DIN 3016



Material

- stainless steel 1.4301

Applications

- Reductions with cone flanges
- Combiflex PU cone flanges
- Steel piping with cone flanges
- Pipe bends/elbows with cone flanges
- for quick connectors from: Metal columns with cone flanges

Properties

- easy to install
- rust-free
- with safety pin to prevent from an inadvertent opening
- robust
- quick-fix clamps for cone flanges in acc.to DIN 3016

DN	D mm (min. free space)	R mm (free space for opening)	Weight/kg/piece	Article No.
50	147	103	0,2	623-050-900
65	158	103	0,26	623-065-900
80	169	103	0,29	623-080-900
100	212	170	0,46	623-100-900
125	241	186	0,78	623-125-900
150	266	202	0,86	623-150-900
160	275	207	0,91	623-160-900
180	289	215	0,97	623-180-900
200	313	228	1,05	623-200-900
250	360	254	1,24	623-250-900

All data refers to a medium and ambient temperature of +20 °C. * Refers to the inner hose lining. Subject to technical changes and colour deviations.

Combiflex PU Cone Flange Food

in acc. with
DIN 3016

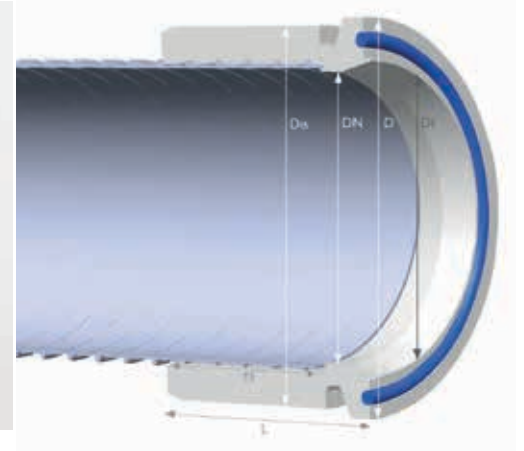

Material

- colour: white
- collar: food-grade polyurethane acc. to EU directive 10/2011 and BfR XXXIX

Applications

- Cast-on quick connectors for all Master-PUR Food hose types

Temperature Range

- -40°C to +90°C
- peaks to +125°C

Properties

- lightweight
- shock-proof
- connection option without adjustable constriction of the cross-section
- PU-sprue: approved for direct contact with foodstuffs acc. to EU directives 10/2011, 1935/2004 (German Consumer Goods Board) and their latest amendments 1282/2011, 1183/2012, 202/2014 and 2015/174 suitable for dry, watery, acidic, fatty as well as alcoholic foodstuffs (excluding spirits)
- high tension-proof
- easy to install when using quick-fit clamp connectors
- abrasion, microbe and hydrolysis resistant
- dissipation of electrostatic charge via integrated earthing plate available for prefixed version

Product Variations

DN hose	Total length mm	Weight kg/piece	Article no. male part	Article no. female part
50	68	0,1	520-050-50V	520-050-50M
65	78	0,15	520-065-50V	520-065-50M
80	83	0,18	520-080-50V	520-080-50M
100	88	0,35	520-100-50V	520-100-50M
125	95	0,42	520-125-50V	520-125-50M
150	105	0,63	520-150-50V	520-150-50M
160	105	0,7	520-160-50V	520-160-50M
180	110	0,8	520-180-50V	520-180-50M
200	110	0,87	520-200-50V	520-200-50M

All data refers to a medium and ambient temperature of +20 °C. * Refers to the inner hose lining. Subject to technical changes and colour deviation.

Production on request

- Order-specific production in above listed sizes, in White, pre-fixed, water-tight version for Master-PUR Food hoses

Technical data

DN hose	D: outer Ø flange	Da: outer Ø sprue	L: total length	di: tube inner diameter
50	78	75	68	54,5
65	91	90	78	70,3
80	104	105	83	82,5
100	129	131	88	107,1
125	161	156	95	131,7
150	190	184	105	159,3
160	200	190	105	167
180	216	210	110	182,9
200	242	235	110	207,3

All data refers to a medium and ambient temperature of +20 °C. * Refers to the inner hose lining. Subject to technical changes and colour deviation.



Milk powder offers a range of different possible uses. It is used to manufacture numerous products, including cheese, yoghurt, confectionery and baked goods, as a basis for instant baby formula, and in the production of chocolate in particular. Whey powder is used to manufacture food products such as margarine and confectionery, amongst other things, and is also used as pig feed.

Water is withdrawn from the base product (milk or liquid whey) through the drying process during production of milk powder or whey powder.

Spray drying, agglomeration and mixing plants are commonplace in the food industry wherever milk fats and vegetable fats are processed. The production processes for skimmed milk powder, whey powder, milk powder for baby formula, fat powder or coffee creamer encompass supply of raw materials, pre-processing, the concentration process and drying, right up to packaging of finished products. Masterflex hoses are used in many drying facilities during materials transport - behind cyclones, for instance, or in the silo area or weighing cells, as well as in filling.

Processes such as drying and mixing also determine processing of further dried products such as instant drinks, custard powder, ready-made soups, tea, baking mixes, muesli, cappuccino or cereals. In these cases, too, Masterflex hoses reliably transport raw materials and finished products such as plant extracts, flavourings or seasonings, for example.



Combiflex PU Fixed Flange Food

for counterflanges acc. to DIN 2632/ DIN 2633/ DIN 2673, food-grade quality acc. to EU 10/2011

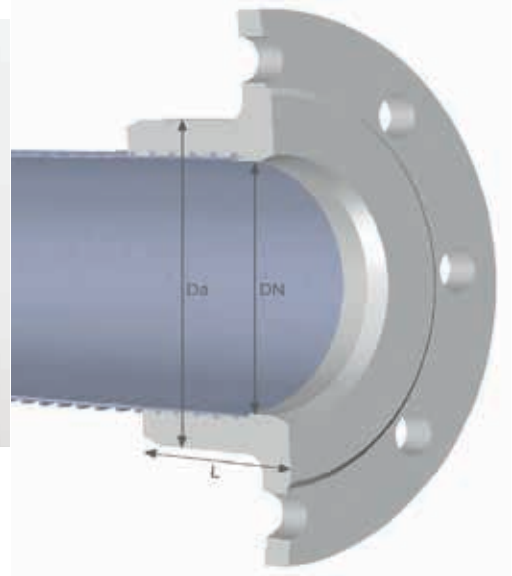

Material

- food-grade polyurethane acc.to EU 10/2011 and BfR XXXIX

Applications

- Cast-on plastic flange for all Master-PUR Food hose types

Temperature Range

- -40°C to +90°C
- peaks to +125°C

Properties

- lightweight
- shock-proof

- connection option without adjustable constriction of the cross-section
- PU-sprue: approved for direct contact with foodstuffs acc.to EU directives 10/2011, 1935/2004 (German Consumer Goods Board) and their latest amendments 1282/2011, 1183/2012, 202/2014 and 2015/174 suitable for dry, watery, acidic, fatty as well as alcoholic food-stuffs (excluding spirits)
- high tension-proof
- simple mounting
- abrasion, microbe and hydrolysis resistant
- Pressure range PN 10/16
- dissipation of electrostatic charge via integrated earthing plate available for prefixed version

Product Variations

DN flange	dA: outer Ø Pipe	DN hose	Both circle in mm	Total length	Weight/piece	Article no.
50	57	50	125	66	0,55	562-050-501
50	60,3	50	125	66	0,55	562-050-502
65	76,1	65	145	76	0,69	562-065-501
65	76,1	70	145	76	0,69	562-070-501
80	88,9	75	160	76	0,85	562-075-501
80	88,9	80	160	76	0,85	562-080-501
100	108	100	180	86	1,13	562-100-501
100	114,3	100	180	86	1,13	562-100-502

All data refers to a medium and ambient temperature of +20 °C. * Refers to the inner hose lining. Subject to technical changes and colour deviation.

Production on request

- Order-specific production in above listed sizes, in White, pre-fixed, water-tight version for Master-PUR Food hoses

Technical data

DN hose	Da: outer-Ø cast part	L: Total length
50	75	66
65	90	76
75	105	76
100	131	86
120	156	92
125	156	92

All data refers to a medium and ambient temperature of +20 °C. * Refers to the inner hose lining. Subject to technical changes and colour deviation.

Combiflex PU Swivel Flange Food

for counterflanges
acc. to DIN 2633/
DIN 2633/ DIN 2673,
food-grade quality
acc. to EU 10/2011

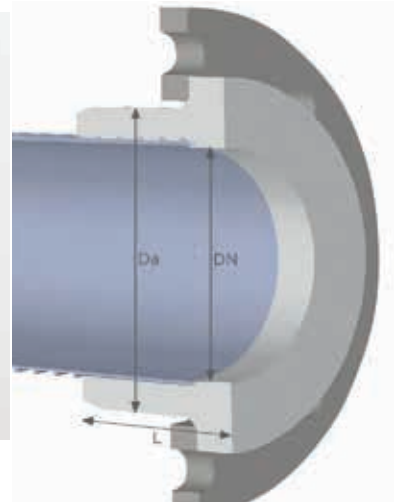

Material

- colour: white
- collar: food-grade polyurethane acc. to EU directive 10/2011 and BfR XXXIX
- loose flange: stainless steel

Applications

- Cast-on plastic flange for all Master-PUR Food hose types

Temperature Range

- -40°C to +90°C
- peaks to +125°C

Product Variations

DN flange	dA: outer Ø Pipe	DN hose	both circle in mm	Total length	Weight/piece	Article no.
50	57	50	125	66	2,24	572-050-501
50	60,3	50	125	66	2,24	572-050-502
65	76,1	65	145	76	2,8	572-065-501
65	76,1	70	145	76	2,75	572-070-501
80	88,9	75	160	76	3,39	572-075-501
80	88,9	80	160	76	3,34	572-080-501
100	108	100	180	86	3,79	572-100-501
100	114,3	100	180	86	3,79	572-100-502
125	133	120	210	92	4,97	572-120-501
125	139,7	120	210	92	4,97	572-120-502
125	133	125	210	92	4,86	572-125-501
125	139,7	125	210	92	4,86	572-125-502
150	159	140	240	98	6,17	572-140-501
150	159	150	240	98	5,9	572-150-501
150	168,3	150	240	98	5,9	572-150-502
150	177,8	160	240	98	5,61	572-160-501

All data refers to a medium and ambient temperature of +20 °C. * Refers to the inner hose lining. Subject to technical changes and colour deviation.

Production on request

- Order-specific production in above listed sizes, in White, pre-fixed, water-tight version for Master-PUR Food hoses

Technical data

DN hose	Da: outer-Ø cast part	L: total length
50	75	66
65	90	76
80	105	76
100	131	86
125	156	92
150	184	98

All data refers to a medium and ambient temperature of +20 °C. * Refers to the inner hose lining. Subject to technical changes and colour deviation.

Combiflex PU Threaded Sockets Food

in acc. with DIN ISO
228
food-grade quality
acc. to EU 10/2011



Material

- food-grade polyurethane acc.to EU 10/2011 and BfR XXXIX
- colour: white

Applications

- Cast-on threaded connectors for all Master-PUR Food hose types

Temperature Range

- -40°C to +90°C
- peaks to +125°C

Properties

- lightweight
- shock-proof
- PU-sprue: approved for direct contact with foodstuffs acc.to EU directives 10/2011, 1935/2004 (German Consumer Goods Board) and their latest amendments 1282/2011, 1183/2012, 202/2014 and 2015/174 suitable for dry, watery, acidic, fatty as well as alcoholic foodstuffs (excluding spirits)
- simple mounting
- abrasion-resistant
- microbe and hydrolysis-resistant

DN hose	G inch	Total length mm	Weight/piece	Article no.
50	2	83	0,15	527-050-510
65	2,5	94	0,22	527-065-510
75	3	102	0,25	527-075-510
100	4	124	0,51	527-100-510
125	5	100	0,6	527-125-510
150	6	109	0,9	527-150-510

All data refers to a medium and ambient temperature of +20 °C. * Refers to the inner hose lining Subject to technical changes and colour deviations.

Combiflex Clamp Connection Food

with outer thread,
acc.to DIN ISO 228 -
cast-on
food-grade quality
acc. to EU 10/2011

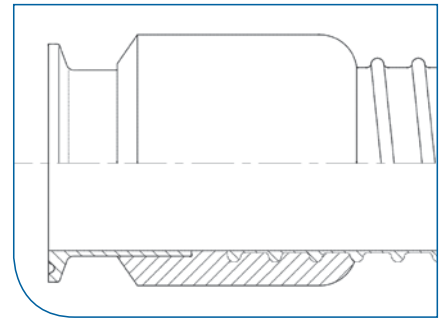

Material

- colour: white
- collar: food-grade polyurethane acc. to EU directive 10/2011 and BfR XXXIX
- VA threaded sockets

Applications

- for application for connectors to machines and piping
- for mounting of valves for solid, liquid and gaseous media
- Cast-on VA (stainless steel) screw connectors with external thread acc. to DIN ISO 228 for all Master-PUR-Food hoses
- Phamaceutical industry
- Chemicals industry
- Food industry

Temperature Range

- -40°C to +90°C
- peaks to +125°C

Properties

- watertight
- rust-free
- PU-sprue: approved for direct contact with foodstuffs acc.to EU directives 10/2011, 1935/2004 (German Consumer Goods Board) and their latest amendments 1282/2011, 1183/2012, 202/2014 and 2015/174 suitable for dry, watery, acidic, fatty as well as alcoholic food-stuffs (excluding spirits)
- good flow characteristics
- odourless/tasteless
- good chemical resistance
- high tensile strength
- dissipation of electrostatic charges via grounding connection between hose and valve/fitting

DN hose	outer Ø gate	Da: outer-Ø cast part- mm	Weight/piece incl. gate	Article no. gate	Article no. clamp-connection
32	32	52	0,41	528-032-510	648-032-803
38	40	60	0,5	528-038-510	648-038-803
40	40	60	0,48	528-040-510	648-040-803
50	50	71	0,64	528-050-510	648-050-803
65	66	91	1,06	528-065-510	648-065-803
75	80	106	1,5	528-075-510	648-080-803
80	80	106	1,43	528-080-510	648-080-803
100	100	130	2,05	528-100-510	648-100-803
125	125	156	1,48	528-125-510	648-125-803
150	150	184	1,78	528-150-510	648-150-803

All data refers to a medium and ambient temperature of +20 °C. * Refers to the inner hose lining Subject to technical changes and colour deviations.

Combiflex Clamp Ring Seal

for clamp
connections acc.to
DIN 32676



Material

- NBR, Colour. white

Applications

- for application for connectors to machines and piping
- Sealing rings for solid, liquid and gaseous media in food, pharmaceutical and chemicals industries
- Sealing rings for hose brackets with clamp connector acc. to DIN 32676 series A

Temperature Range

- -25°C to +120°C
- peaks to +150°C

Properties

- materials adhere to the food-grade regulations DIN 32676 series A
- provides watertight connections
- odourless/tasteless
- good chemical resistance
- high tensile strength

DS	inner Ø Di mm	outer Ø Da mm	Article no.
32	32,2	52,7	647-032-806
40	38,2	52,7	647-040-806
50	50,2	66,2	647-050-806
65	66,2	93,2	647-065-806
80	81,2	108,2	647-080-806
100	100,2	121,2	647-100-806
125	125,2	155	647-125-806
150	150,2	183	647-150-806

All data refers to a medium and ambient temperature of +20 °C. * Refers to the inner hose lining Subject to technical changes and colour deviations.

Sample applications in pharmaceuticals manufacturing



In the area of bulk goods handling - For example in the pharma industry - the hoses employed are subjected to high levels of strain. They provide connections between pipelines and, for example, a vacuum conveyor or, in some circumstances, can extend directly to a product feeding point or a container. They serve to provide suction from charging hoppers, big bags or containers and must withstand heavy loads and fulfil the highest standards of quality.

Particularly in the pharma industry, great importance is attached to the highest possible hygiene requirements and to the ability to be cleaned without leaving residues. Products, their packaging, and all commodities must undergo strict inspections throughout the entire chain of production.

Commodities which come into contact with products must not cause product contamination or compromise their quality. Therefore, Masterflex food hoses - along with all foodstuff-compatible products - are subject to EC regulation no. 2023/2006/EC, also known as GMP: "good manufacturing practice".



The hoses are used for suction, transportation and supply of various substances such as powders, dusts, granules, pigments, capsules, tablets or small parts. During transport of media in powder form, in particular, it is important to avoid unloading due to electrostatic charges and to minimise the risk of dust explosion. Therefore, all Masterflex food hoses are also available as antistatic versions.



Combiflex Clamp Connection Hinged Clamp

for clamp Connections acc.to DIN 32676



Material

- stainless steel 1..4301

Applications

- Fitting for solid, liquid and gaseous media in food, pharmaceuticals and chemicals industries
- for application for connectors to machines and piping

Properties

- materials adhere to the food-grade regulations DIN 32676 series A
- provides watertight connections
- odourless/tasteless
- can be steam-sterilized
- good chemical resistance
- high tensile strength

DS	Weight/piece kg	Article no.
32	0,23	647-032-804
40	0,23	647-040-804
50	0,31	647-050-804
65	0,31	647-065-804
80	0,41	647-080-804
100	0,41	647-100-804
125	1,17	647-125-804
150	1,34	647-150-804

All data refers to a medium and ambient temperature of +20 °C. * Refers to the inner hose lining Subject to technical changes and colour deviations.

Combiflex VA Threaded Sockets Food

with outer thread,
acc.to DIN ISO 228 -
cast-on,
food-grade quality
acc. to EU 10/2011

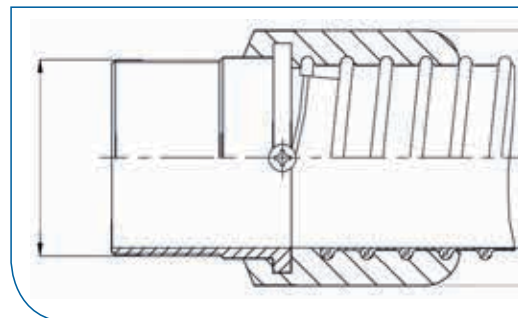

Material

- colour: white
- collar: food-grade polyurethane acc. to EU directive 10/2011 and BfR XXXIX
- VA threaded sockets

Applications

- for application for connectors to machines and piping
- for mounting of valves for solid, liquid and gaseous media
- Cast-on VA (stainless steel) screw connectors with external thread acc. to DIN ISO 228 for all Master-PUR-Food hoses
- Pharmaceutical industry
- Chemicals industry
- Food industry

Properties

- watertight
- rust-free
- PU-sprue: approved for direct contact with foodstuffs acc.to EU directives 10/2011, 1935/2004 (German Consumer Goods Board) and their latest amendments 1282/2011, 1183/2012, 202/2014 and 2015/174 suitable for dry, watery, acidic, fatty as well as alcoholic food-stuffs (excluding spirits)
- good flow characteristics
- odourless/tasteless
- dissipation of electrostatic charges via grounding connection between hose and valve/fitting
- good chemical resistance
- high tensile strength

Temperature Range

- -40°C to +90°C
- peaks to +125°C

Production on request

- Order-specific production in above listed sizes, in White, pre-fixed, water-tight version for Master-PUR Food hoses

DN hose	Connector thread size (in.)inch	Da: outer diameter gate mm	Weight/piece incl. gate kg	Article no.gate	Article no. threaded socket
25	1	42	0,19	528-025-510	648-025-804
32	1 1/4	52	0,34	528-032-510	648-032-804
38	1 1/2	60	0,42	528-038-510	648-038-804
40	1 1/2	60	0,42	528-040-510	648-040-804
50	2	71	0,55	528-050-510	648-050-804
65	2 1/2	90	0,82	528-065-510	648-065-804
75	3	106	1,34	528-075-510	648-075-804
80	3 1/2	106	0,96	528-080-510	648-080-804
100	4	130	1,94	528-100-510	648-100-804
125	5	155	2,43	528-125-510	648-125-804
150	6	184	2,98	528-150-510	648-150-804

All data refers to a medium and ambient temperature of +20 °C. * Refers to the inner hose lining Subject to technical changes and colour deviations.

Combiflex Dairy Fitting Threaded Hose Sockets

acc.to 11851 - cast-on/pre-fixed, food-grade quality acc. to EU 10/2011

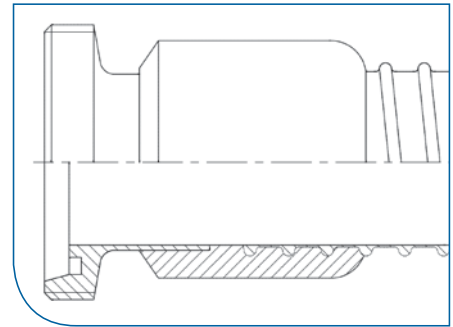

Material

- colour: white
- collar: food-grade polyurethane acc. to EU directive 10/2011 and BfR XXXIX
- threaded hose sockets acc.to DIN 11851: stainless steel
- ring seal: NBR, colour: blue

Applications

- Cast-on pipe screw connection acc. to DIN 11851 for Master-PUR Food hoses
- Fitting for solid, liquid and gaseous media in food, pharmaceuticals and chemicals industries

Temperature Range

- -40°C to +90°C
- peaks to +125°C

Properties

- watertight
- rust-free
- PU-sprue: approved for direct contact with foodstuffs acc.to EU directives 10/2011, 1935/2004 (German Consumer Goods Board) and their latest amendments 1282/2011, 1183/2012, 202/2014 and 2015/174 suitable for dry, watery, acidic, fatty as well as alcoholic foodstuffs (excluding spirits)
- good flow characteristics
- threaded supports: materials acc.to food industry regulations DIN 11851
- odourless/tasteless
- good chemical resistance
- high tensile strength
- dissipation of electrostatic charges via grounding connection between hose and valve/fitting

Production on request

- Order-specific production in listed sizes for Master PUR Food hoses.

DN hose	Access DS	Thread (DG) acc.to DIN 405-1	Weight/piece incl. gate kg	Article no. gate	Article no. threaded socket	Article no. cone socket
32	32	RD 58x1/6	0,46	528-032-510	648-032-801	648-032-802
38	40	RD 65x1/6	0,5	528-038-510	648-038-801	648-038-802
40	40	RD 65x1/6	0,58	528-040-510	648-040-801	648-040-802
50	50	RD 78x1/6	0,72	528-050-510	648-050-801	648-050-802
65	65	RD 95x1/6	0,97	528-065-510	648-065-801	648-065-802
75	80	RD 110x1/4	1,2	528-075-510	648-075-801	648-075-802
80	80	RD 110x1/4	1,3	528-080-510	648-080-801	648-080-802
100	100	RD 130x1/4	2,1	528-100-510	648-100-801	648-100-802
125	125	RD 160x1/4	2,63	528-125-510	648-125-801	648-125-802
150	150	RD 190x1/4	3,4	528-150-510	648-150-801	648-150-802

All data refers to a medium and ambient temperature of +20 °C. * Refers to the inner hose lining Subject to technical changes and colour deviations.

Combiflex Dairy Fitting Cone Sockets

with locknut acc.to
DIN 11851 - cast-on/
pre-fixed,
food-grade quality
acc. to EU 10/2011

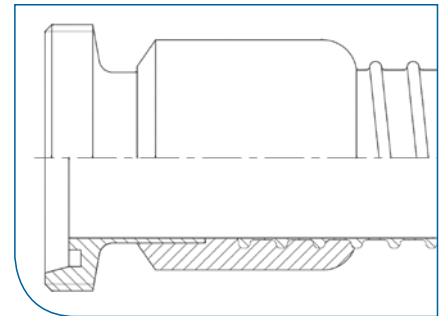

Material

- colour: white
- collar: food-grade polyurethane acc. to EU directive 10/2011 and BfR XXXIX
- locknut: stainless steel
- conical hose sockets, stainless steel

Applications

- Cast-on pipe screw connection acc. to DIN 11851 for Master-PUR Food hoses
- Fitting for solid, liquid and gaseous media in food, pharmaceuticals and chemicals industries

Temperature Range

- -40°C to +90°C
- peaks to +125°C

Properties

- watertight
- rust-free
- PU-sprue: approved for direct contact with foodstuffs acc.to EU directives 10/2011, 1935/2004 (German Consumer Goods Board) and their latest amendments 1282/2011, 1183/2012, 202/2014 and 2015/174 suitable for dry, watery, acidic, fatty as well as alcoholic foodstuffs (excluding spirits)
- good flow characteristics
- threaded supports: materials acc.to food industry regulations DIN 11851
- odourless/tasteless
- good chemical resistance
- high tensile strength
- dissipation of electrostatic charges via grounding connection between hose and valve/fitting

Production on request

- Order-specific production in listed sizes for Master PUR Food hoses from DN 32 - DN 150

Available on request

- Available on request in aseptic version acc. to DIN 11864-1, as weld-on version, pressed, other materials

DN	Access DS	Thread (DG) acc.to DIN 405-1	weight/piece incl. gate kg	Article no. gate	Article no. cone socket	Article no. threa- ded socket
32	32	RD 58x1/6"	0,64	528-032-510	648-032-802	648-032-801
38	40	RD 65x1/6"	0,76	528-038-510	648-038-802	648-038-801
40	40	RD 65x1/6"	0,81	528-040-510	648-040-802	648-040-801
50	50	RD 78x1/6"	1,01	528-050-510	648-050-802	648-050-801
65	65	RD 95x1/6"	1,49	528-065-510	648-065-802	648-065-801
75	80	RD 110x1/4"	1,73	528-075-510	648-075-802	648-075-801
80	80	RD 110x1/4"	1,85	528-080-510	648-080-802	648-080-801
100	100	RD 130x1/4"	2,9	528-100-510	648-100-802	648-100-801
125	125	RD 160x1/4"	3,15	528-125-510	648-125-802	648-125-801
150	150	RD 190x1/4"	3,4	528-150-510	648-150-802	648-150-801

All data refers to a medium and ambient temperature of +20 °C. * Refers to the inner hose lining Subject to technical changes and colour deviations.

Combiflex Dairy Fitting Ring Seal

for threaded sockets
acc.to DIN 11851



Material

- NBR, colour: white

Applications

- NBR, colour: white
- Chemical industry
- Pharmaceutical industry
- Food industry
- for application for connectors to machines and piping
- Sealing rings for screw connectors acc. to DIN 11851
- Sealing rings for solid, liquid and gaseous media in food, pharmaceutical and chemicals industries

Properties

- materials adhere to the food-grade regulations DIN 11851
- odourless/tasteless
- can be steam-sterilized
- good chemical resistance
- high tensile strength

Temperature Range

- -25°C to +120°C
- peaks to +150°C

- Deliverable from stock for sockets with Dairy Fitting outer threads acc. to DIN 11851 from DS 32 - DS 150

DS	inner diameter Di mm	thickness S mm	Article no.
32	36	5	647-032-805
40	42	5	647-040-805
50	54	5	647-050-805
65	71	5	647-065-805
80	85	5	647-080-805
100	104	6	647-100-805
125	130	7	647-125-805
150	155	7	647-150-805

All data refers to a medium and ambient temperature of +20 °C. * Refers to the inner hose lining Subject to technical changes and colour deviations.

Manufacturing of beauty and household cleaning products



Masterflex hoses are also crucial to the manufacturing of beauty products and domestic cleaning products. Spiral hoses are a good option, for example, in cases where micronised wax additives are transported during the production of shoe polish, car polish or floor cleaners.

The use of Masterflex **templine**[®] heated hoses is recommended wherever wax or fats have to be maintained at a given temperature.

Masterflex hoses can also be used in vacuum processing facilities, however. They must then comply with the relevant requirements pertaining to pressure and vacuum.

Such systems are commonly used in the cosmetics and pharma industries for processing liquid and semi-solid products. Powder and/or liquids are mixed, suspended, dispersed and/or emulsified during such processes.



templine® -A heated hose

Electrically heated hose for external electric power supply/ temperature regulations

FDA 21 CFR 177.1550
USP Class VI



Material

- Medium hose in PTFE with high chemical resistance. Outer casing in mechanically stable, abrasion-resistant materials. Thermal insulation: optional silicone foam or silicone-free textile fleece

Applications

- Maintaining and increasing temperature for gases, granules and liquids of varying viscosities e.g. sugar-coating, chocolate production, beverages industry, gas analysis, etc.

Properties

- Materials acc. to FDA 21 CFR 177.1550
- Homogeneous heat distribution
- Low energy requirement
- Connecting armatures in stainless steel
- Good flexibility
- Use up to 500 bar and vacuum
- Anti-slip and anti-static versions deliverable

Temperature Range

- One to three-fold high pressure PTFE hose up to +250 °C
- Metal corrugated hose up to +300 °C

Delivery variants

- Deliverable on request in aseptic design acc. to DIN 11864, can be welded, compressed, other materials
- Deliverable on request: templine® - A heating hose up to 100 m length

DN	Outer diameter	Protection Mode	Article no.	Length
4	22	IP65	on request	from 0,3m
6	22	IP65	on request	from 0,3m
8	22	IP65	on request	from 0,3m
10	28	IP65	on request	from 0,3m
13	28	IP65	on request	from 0,3m
16	28	IP65	on request	from 0,3m
20	59	IP65	on request	from 0,3m
25	79	IP65	on request	from 0,3m
32	79	IP65	on request	from 0,3m
40	79	IP65	on request	from 0,5m
50	79	IP65	on request	from 0,5m
65	90	IP65	on request	from 0,5m
80	108	IP65	on request	from 0,5m
100	129	IP65	on request	from 0,5m

templine® -R heated hose

Electrically heated hose with integrated temperature controller

FDA 21 CFR 177.1550
USP Class VI



Material

- Medium hose in PTFE with high chemical resistance. Outer casing in mechanically stable, abrasion-resistant materials. Thermal insulation: optional silicone foam or silicone-free textile fleece

Applications

- Maintaining and increasing temperature for gases, granules and liquids of varying viscosities: sugar-coating, chocolate production, beverages industry, gas analysis, etc.

Properties

- Materials acc. to FDA 21 CFR 177.1550
- Homogeneous heat distribution
- Low energy requirement
- Connecting armatures in stainless steel
- Good flexibility
- Use up to 500 bar and vacuum
- Anti-slip and anti-static versions deliverable

Temperature Range

- One to three-fold high pressure PTFE hose up to +250 °C
- Metal corrugated hose up to +300 °C

Delivery variants

- Deliverable on request in aseptic design acc. to DIN 11864, can be welded, compressed, other materials
- Deliverable on request: templine® - A heating hose up to 100 m length

DN	Outer diameter	Protection Mode	Article no.	Length
4	22	IP65	on request	from 0,3m
6	22	IP65	on request	from 0,3m
8	22	IP65	on request	from 0,3m
10	28	IP65	on request	from 0,3m
13	28	IP65	on request	from 0,3m
16	28	IP65	on request	from 0,3m
20	59	IP65	on request	from 0,3m
25	79	IP65	on request	from 0,3m
32	79	IP65	on request	from 0,3m
40	79	IP65	on request	from 0,5m
50	79	IP65	on request	from 0,5m
65	90	IP65	on request	from 0,5m
80	108	IP65	on request	from 0,5m
100	129	IP65	on request	from 0,5m

templine® -B heated hose

Electrically heated hose with integrated temperature controller / safety temperature limiter

FDA 21 CFR 177.1550
USP Class VI



Material

- Medium hose in PTFE with high chemical resistance. Outer casing in mechanically stable, abrasion-resistant materials. Thermal insulation: optional silicone foam or silicone-free textile fleece

Applications

- Maintaining and increasing temperature for gases, granules and liquids of varying viscosities e.g. sugar-coating, chocolate production, beverages industry, gas analysis, etc.

Properties

- Materials acc. to FDA 21 CFR 177.1550
- Homogeneous heat distribution
- Low energy requirement
- Connecting armatures in stainless steel
- Good flexibility
- Use up to 500 bar and vacuum
- Anti-slip and anti-static versions deliverable

Temperature Range

- One to three-fold high pressure PTFE hose up to +250 °C
- Metal corrugated hose up to +300 °C

Delivery variants

- Deliverable on request in aseptic design acc. to DIN 11864, can be welded, compressed, other materials
- Deliverable on request: templine® - A heating hose up to 100 m length

DN	Outer diameter	Protection Mode	Article no.	Length
4	22	IP65	on request	from 0,3m
6	22	IP65	on request	from 0,3m
8	22	IP65	on request	from 0,3m
10	28	IP65	on request	from 0,3m
13	28	IP65	on request	from 0,3m
16	28	IP65	on request	from 0,3m
20	59	IP65	on request	from 0,3m
25	79	IP65	on request	from 0,3m
32	79	IP65	on request	from 0,3m
40	79	IP65	on request	from 0,5m
50	79	IP65	on request	from 0,5m
65	90	IP65	on request	from 0,5m
80	108	IP65	on request	from 0,5m
100	129	IP65	on request	from 0,5m

templine® -F heated hose

Electrically heated hose with integrated frost protection

FDA 21 CFR 177.1550
USP Class VI



Material

- Medium hose in PTFE with high chemical resistance. Outer casing in mechanically stable, abrasion-resistant materials. Thermal insulation: optional silicone foam or silicone-free textile fleece

Applications

- Frost protection/temperature maintenance for gases, granulates and liquids of varying viscosities: sugar-coating, chocolate production, beverages industry, gas analysis, etc.

Properties

- Materials acc. to FDA 21 CFR 177.1550
- Homogeneous heat distribution
- Low energy requirement
- Connecting armatures in stainless steel
- Good flexibility
- Use up to 500 bar and vacuum
- Anti-slip and anti-static versions deliverable

Temperature Range

- One to three-fold high pressure PTFE hose up to +250 °C
- Metal corrugated hose up to +300 °C

Delivery variants

- Deliverable on request in aseptic design acc. to DIN 11864, can be welded, compressed, other materials
- Deliverable on request: templine® - A heating hose up to 100 m length

DN	Outer diameter	Protection Mode	Article no.	Length
4	22	IP65	on request	from 0,3m
6	22	IP65	on request	from 0,3m
8	22	IP65	on request	from 0,3m
10	28	IP65	on request	from 0,3m
13	28	IP65	on request	from 0,3m
16	28	IP65	on request	from 0,3m
20	59	IP65	on request	from 0,3m
25	79	IP65	on request	from 0,3m
32	79	IP65	on request	from 0,3m
40	79	IP65	on request	from 0,5m
50	79	IP65	on request	from 0,5m
65	90	IP65	on request	from 0,5m
80	108	IP65	on request	from 0,5m
100	129	IP65	on request	from 0,5m

Insulated hose line for simple temperature maintenance

FDA 21 CFR 177.1550
USP Class VI



Material

- Medium hose in PTFE with high chemical resistance. Outer casing in mechanically stable, abrasion-resistant materials. Thermal insulation: optional silicone foam or silicone-free textile fleece

Applications

- Frost protection/temperature maintenance for gases, granulates and liquids of varying viscosities: sugar-coating, chocolate production, beverages industry, gas analysis, etc.

Properties

- Materials acc. to FDA 21 CFR 177.1550
- Connecting armatures in stainless steel
- Good flexibility
- Use up to 500 bar and vacuum
- Anti-slip and anti-static versions deliverable

Temperature Range

- One to three-fold high pressure PTFE hose up to +250 °C
- Metal corrugated hose up to +300 °C

Delivery variants

- Deliverable on request in aseptic design acc. to DIN 11864, can be welded, compressed, other materials
- Deliverable on request: templine® - A heating hose up to 100 m length

DN	Outer diameter	Protection Mode	Article no.	Length
4	22	IP65	on request	from 0,3m
6	22	IP65	on request	from 0,3m
8	22	IP65	on request	from 0,3m
10	28	IP65	on request	from 0,3m
13	28	IP65	on request	from 0,3m
16	28	IP65	on request	from 0,3m
20	59	IP65	on request	from 0,3m
25	79	IP65	on request	from 0,3m
32	79	IP65	on request	from 0,3m
40	79	IP65	on request	from 0,5m
50	79	IP65	on request	from 0,5m
65	90	IP65	on request	from 0,5m
80	108	IP65	on request	from 0,5m
100	129	IP65	on request	from 0,5m

templine® -A / -R / -B VARIO heated hose

Electrically heated hoses with replaceable internal hose

FDA 21 CFR 177.1550
USP Class VI



Material

- Medium hose in PTFE with high chemical resistance. Outer casing in mechanically stable, abrasion-resistant materials. Thermal insulation: optional silicone foam or silicone-free textile fleece

Applications

- Maintaining and increasing temperature for gases, granules and liquids of varying viscosities e.g. sugar-coating, chocolate production, beverages industry, gas analysis, etc.

Properties

- Replaceable PTFE hose
- Materials acc. to FDA 21 CFR 177.1550
- Homogeneous heat distribution
- Low energy requirement
- Connecting armatures in stainless steel
- Good flexibility
- Use up to 500 bar and vacuum
- Anti-slip and anti-static versions deliverable

Temperature Range

- One to three-fold high pressure PTFE hose up to +250 °C
- Metal corrugated hose up to +300 °C

Delivery variants

- templine® - A VARIO: Electrically heated hose for external electric power supply/temperature regulation
- templine® - R VARIO: Electrically heated hose with integral electronic thermostat
- templine® - B VARIO: Electrically heated hose with integral electronic thermostat / temperature limiter
- Deliverable on request in aseptic design acc. to DIN 11864, can be welded, compressed, other materials
- Deliverable on request: templine® - A / -R / -B VARIO heated hoses up to 20 m length

DN	Outer diameter	Protection Mode	Article no.	Length
4	22	IP65	on request	from 0,3m
6	22	IP65	on request	from 0,3m
8	22	IP65	on request	from 0,3m
10	28	IP65	on request	from 0,3m
13	28	IP65	on request	from 0,3m
16	28	IP65	on request	from 0,3m
20	59	IP65	on request	from 0,3m

Project Checklist

Electrically heated hoses from the **templine®** product range are individual solutions, and the calculations behind them are derived from the data from the user. Please complete this form as fully as possible, since this will enable us to prepare the best possible product solution to suit you.

Fax: +49 (0)209-97077-33 Tel.: +49 (0)209 97077-94 templine@MasterflexGroup.com

Contact Data

Company: _____ Departement: _____
 Street: _____ Phone: _____
 City/Postal Code: _____ Fax: _____
 Contact: _____ Cell Phone: _____
 Function: _____ E-Mail: _____

Description of Application

Hose Inner Diameter (mm): _____ Other (mm): _____
 Hose length (m): _____ Pressure (bar): _____
 Vacuum (mm water head): _____ Number of Hoses: _____
 Medium Type: granules gaseous
 liquid viscous
 Medium Temperature (°C): _____ Start-up Temperature (°C): _____
 Critical Medium Temperature (°C): _____ Ambient: Indoor Area Outdoor Area
 Humidity/Fog: Yes No
 Wind (>2ms/s): Yes No City/State: _____
 Installation Site: Application: frost protection
 Western Europe/Atlantic Ocean, maintain temperature
 Southern Europe/Coast, Southern Europe/Inland, increase in temperature
 Western Europe/Inland, Northern Europe/ Inland, Customer required load (W):: _____
 Northern Europe/Coast, Eastern Europe, Operating Voltage: _____
 North Asia, South Asia, Australia, South America, External Effects: tensile-/compressive-stress
 Central America, North America: permanent frost condition
 direct solar irradiation
 Config. of templine-A (external Supply)
 heated hose: templine-R (controller)
 templine temperature control
 templine-B (with temperature limiter)

Hose Configuration

Inner-/Medium hose:
 PTFE PTFE pressure max 264 bar PTFE pressure max 500 bar
 PTFE-corrugated hose PTFE-corrugated hose reinforced
 Metal corrugated hose Metal corrugated hose reinforced
 Other: _____
 silicone free: Yes No
 Thermal Insulation: Silicone Foam Fleece (silicone free)
 Hose fitting material: steel brass stainless steel

Design Swivel Nut, 24°-Cone, metric BSP-conical
 Outer Thread, 24°-inner cone metric BSP-conical
 Swivel Nut, 60°-cone metric BSP-conical
 Swivel Nut, flat-sealing metric BSP-conical
 flat-sealing/Outer Thread metric BSP-conical

Replaceable Inner-/Medium carrying- hose: Yes No

Protective PA-Braiding KEVLAR-Braiding PUR L-EL corrugated hose
 jacked: HYPALON-Spiral hose Stainless steel braiding Silicone outer coating

Mechanical stress: Yes No Problem definition: _____

Type of installation: Stationary installation medium strength movement high tensile / bending movement

Approvals/Certificates: _____

Notes

Picture credits title: © aykulerd - Fotolia.com, page 3: centre © Devan Georgiev - Fotolia.com, page 13: top right © Kevin - Fotolia.com, centre right © popov48 - Fotolia.com, row below from left to right: © umberto leporini - Fotolia.com, © Alterfaller - Fotolia.com, © Illesro - Fotolia.com, © Alterfaller - Fotolia.com, © Alterfaller - Fotolia.com



Masterflex SE
Willy-Brandt-Allee 300
45891 Gelsenkirchen, Germany
Tel. +49 209 97077-0
Fax +49 209 97077-33
info.masterflex@MasterflexGroup.com
www.masterflex.de
A MASTERFLEX GROUP COMPANY

 **MASTERFLEX GROUP**
Connecting Values