

Werkzeughürsten Rotary Wire Brushes



Wir haben mehr Lösungen als Sie Probleme.

Und das, obwohl Sie in Europas größtem Bürstensortiment im Grunde genommen nur einen einzigen Bürstentyp finden: Nämlich genau den, den Sie benötigen. Und den wir speziell für Ihre individuellen Anforderungen produzieren. Weil wir uns bei KULLEN weniger als Hersteller, sondern vielmehr als Problemlöser verstehen.

Mit diesem Selbstverständnis sind wir gewachsen. Aus dem Familienbetrieb KULLEN wurde ein Familienunternehmen mit 500 Mitarbeitern, 1 Werk in Reutlingen und 2 Zweigwerken in Großbritannien (R.I.B., Llandovery und Kleeneze Sealtech, Bristol) und Auslieferungslagern rund um den Globus. Gewachsen ist dabei auch das Produktionsprogramm von KULLEN.

Auf zwischenzeitlich 140.000 Bürstentypen, die in 70 Länder exportiert werden. So gibt es heute kaum eine Branche oder

einen Anwendungsbereich, für den wir keine Lösung bieten. Mittels modernster Produktionsanlagen mit Fertigungssteuerung, die aus eigenem Know-how entwickelt wurden und intelligenten EDV-Systemen produzieren wir langlebige Produkte speziell nach Ihren Wünschen. Und unsere strengen Qualitätsprüfungen garantieren Ihnen dabei, daß nur hochwertige Produkte bei Ihnen zum Einsatz kommen.

Ganz gleich, um welches Problem es sich also bei Ihnen dreht – bei uns dreht sich alles um Sie. Und wo immer Sie uns brauchen, sind wir für Sie da.



We have more solutions than you might have problems.

Whatever your individual brush requirement may be, we at KULLEN will be able to manufacture it for you. Having the largest range of brushes in Europe we feel sure that we can solve your brushing problems.

Such confidence has enabled KULLEN to grow from a family business to a family association consisting of 500 employees in total with 1 plant in Reutlingen, 2 plants in Britain (R.I.B., Llandovery and Kleeneze Sealtech, Bristol) and distributors all over the world. The KULLEN production programme was raised to approx. 140.000 brush types which are exported to over 70 countries. In fact, there is hardly an industry or application

for which we would be unable to offer a solution. Our ultra modern production lines, developed with our own know-how, and intelligent electronic data processing equipment enable us to manufacture special products with extended life and enhanced performance to meet all needs. The strict quality control in our factories ensures that only first-class brushes will be supplied.

Whatever your problems are - let's face them together. Whenever you need our advice we will be at your entire disposal.

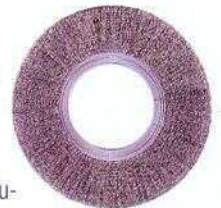

Verkaufsstellen ...	
Representations ...	4

Technische Einführung	
Technical Introduction	6

Topfbürsten	
Cup Brushes	8



Schaftbürsten	
Shaft-Mounted Brushes	20



Innenbürsten	
Interior Brushes	36

Rundbürsten	
Circular Brushes	40



Einzelscheiben-Bürsten	
Single-Section Brushes	44



SH-Rundbürsten	
SH-Circular Brushes	56

Handbürsten	
Scratch Brushes	62



Informationen zu wichtigen Anwendungen	
Information concerning important applications	66

Informationen zum Gesamtprogramm	
Information concerning total product range	68

Verkaufsstellen von KULLEN



Europe

Austria: Vienna
Belgium: Wandre, Brussels
Bulgaria: Veliko Tarnovo
Czech Republic: Klatovy
Denmark: Rodovre, Rungsted Kyst
Estonia: Tallinn
Finland: Helsinki, Turku
France: Paris, Poissy
Great Britain: Llandovery Dyfed,
Bristol
Greece: Athens
Hungary: Budapest
Ireland: Carlow
Italy: Orbassano, Milan
Lithuania: Jonava
Netherlands: Heerhugowaard,
Soest, Alkmaar, S-Gravenhage
Norway: Oslo, Forus
Poland: Bielsko-Biala
Portugal: Vila Nova
Russia: Moscow, St. Petersburg,
Voronezh
Slovakia: Bratislava
Spain: Vitoria, El Masnou
Sweden: Solna
Switzerland: Wil
Turkey: Istanbul
Ukraine: Kiew

 **Kullen**
Die Welt der Bürstentechnik

Möchten Sie mit einem der aufgeführten Büros Kontakt aufnehmen,
so kontaktieren Sie uns unter nachfolgender Faxnummer: +49 (0) 7121/142-260.
Sie erhalten dann die genaue Adresse inklusive Fax- und Telefonnummer.

If you wish to contact one of above-mentioned offices please do not hesitate
to contact us under following fax number: +49 (0) 7121/142-260. We will
immediately send needed address including telephone- and fax number.

South America

Argentina: Buenos Aires
Brazil: Belo Horizonte
Chile: Santiago de Chile
Colombia: Barranquilla
Costa Rica: San Jose
Ecuador: Guayaquil
Guatemala: Guatemala Ciudad
Peru: Lima

 **Kullen**
Die Welt der Bürstentechnik

Agents and Sales Departments of KULLEN

North America

Canada: Quebec
Mexico: Xalostoc
USA: New Jersey

 **Kullen**
Die Welt der Bürstentechnik

Asia

Hong Kong: Hong Kong
India: Bombay
Indonesia: Jakarta
Japan: Amagasaki, Osaka
Korea: Seoul, Pusan
Malaysia: Kuala Lumpur
Pakistan: Lahore
Philippines: Manila
Singapore: Singapore
Taiwan: Taipei

 **Kullen**
Die Welt der Bürstentechnik

Australia

Dingley, Kilburn, St. Marys

 **Kullen**
Die Welt der Bürstentechnik

Africa

Egypt: Alexandria
South Africa: Kempton Park
Tunis: Tunis

 **Kullen**
Die Welt der Bürstentechnik

Middle East

U. A. E.: Dubai
Bahrain: Manama
Iran: Teheran
Israel: Tel Aviv
Jordan: Amman
Lebanon: Beirut
Kuwait: Kuwait City
Saudi Arabia: Riyadh
Syria: Damascus

 **Kullen**
Die Welt der Bürstentechnik

 **Kullen**
Die Welt der Bürstentechnik

Technische Einführung

In Sachen Sortimentsbreite und -tiefe sind Sie mit **KULLEN** bestens bedient: Für jeden Einsatz können wir Ihnen die passende Bürstenlösung bieten – auch für Spezialanwendungen und ausgefallene Probleme, die in diesem Katalog vielleicht nicht berücksichtigt werden konnten. In diesem Fall, aber auch bei allen Fragen, die Sie zur Technik oder zur Optimierung Ihres Bürsteneinsatzes haben, stehen Ihnen unsere Fachleute gerne persönlich zur Verfügung. Wichtige technische Hinweise grundsätzlicher Art finden Sie auf dieser Seite. Für Sonder- oder Zweifelsfälle sollten Sie sich aber unbedingt von uns direkt beraten lassen.

Typen-Namen und ihre Bedeutung:

Die Typen-Bezeichnung unserer Bürsten weist auf jeweils spezifische Eigenschaften hin.

Record

Bürsten mit gewelltem Draht.

Ultra

Bürsten mit gezopftem Draht.

Multicord

Bürsten mit Draht in Seilkonstruktion.

Delta

Bürsten mit gewelltem Draht, in Kunststoff eingegossen.

Alpha

Bürsten mit ANDERLON-Schleifborsten.

Zur Tabelle Umfangsgeschwindigkeiten:

Die Umfangsgeschwindigkeit ist ein entscheidendes Kriterium für einen optimalen Bürsteneinsatz. Aus der nebenstehenden Tabelle können Sie anhand der Parameter Umdrehungszahl und Bürstendurchmesser die entsprechende Umfangsgeschwindigkeit ablesen. Bitte beachten Sie: Die im Katalog angegebenen Umdrehungszahlen sind maximal zulässige Werte, die keinesfalls überschritten werden dürfen. Die Maximaldrehzahl muß in aller Regel nicht erreicht werden, um den bestmöglichen Bürsteffekt zu erzielen. Je nach Bürstentyp und den zu bearbeitenden Materialien empfehlen wir grundsätzlich bestimmte Umfangsgeschwindigkeiten:

Record, Multicord und Delta:

Stahl – ca. 30 m/sec

NE-Metalle – 18–20 m/sec

Kunststoffe – ca. 15 m/sec

Ultra:

Stahl – 35–40 m/sec

Alpha:

Stahl – 18–20 m/sec

NE-Metalle – 18–20 m/sec

Kunststoffe – ca. 15 m/sec

Was tun bei unerwünschten Bürsteffekten:

Bürstwirkung zu gering:

- Umfangsgeschwindigkeit erhöhen durch größeren Bürstendurchmesser oder höhere Umdrehungszahl (max. UPM beachten).
- Bürste mit geringerer Besatzlänge einsetzen.
- Bürste mit größerem Besatz-(Draht- bzw. Borsten-)durchmesser einsetzen.

Bürstenwirkung zu stark:

- Umfangsgeschwindigkeit reduzieren durch kleineren Bürstendurchmesser oder niedrigere Umdrehungszahl.
- Bürste mit größerer Besatzlänge einsetzen.
- Bürste mit kleinerem Besatz-(Draht- bzw. Borsten-)durchmesser einsetzen.

Oberflächenfinish zu fein:

- Umfangsgeschwindigkeit reduzieren durch kleineren Bürstendurchmesser oder niedrigere Umdrehungszahl.
- Bürste mit geringerer Besatzlänge einsetzen.
- Besatz-(Draht- bzw. Borsten-)durchmesser erhöhen.

Umfangsgeschwindigkeiten

Peripheral speeds

min ⁻¹	Bürsten-Durchmesser in mm / Brush-diameter in mm											
	20	40	50	80	100	125	150	180	200	250	300	350
800				3,35	4,19	5,23	6,28	7,53	8,37	10,47	12,56	14,75
900			2,35	3,77	4,71	5,88	7,06	8,48	9,41	11,77	14,12	16,47
1.150			3,01	4,81	6,01	7,52	9,02	10,83	12,03	15,04	18,04	21,04
1.200	1,26	2,51	3,14	5,02	6,28	7,85	9,41	11,30	12,55	15,69	18,83	21,97
1.400	1,46	2,93	3,66	5,86	7,32	9,15	10,98	13,18	14,84	18,31	21,97	25,63
1.500	1,57	3,14	3,92	6,28	7,85	9,81	11,77	14,13	15,69	19,61	23,54	27,46
1.800	1,88	3,77	4,71	7,54	9,41	11,77	14,12	16,85	18,83	23,54	28,24	32,95
2.000	2,09	4,19	5,23	8,37	10,26	13,08	15,69	18,84	20,92	26,15	31,38	36,61
2.500	2,62	5,23	6,54	10,47	13,08	16,35	19,61	23,55	26,15	32,67	39,23	45,76
2.800	2,93	5,86	7,32	11,72	14,64	18,31	21,97	26,37	29,29	36,61	43,93	51,25
3.000	3,14	6,28	7,85	12,56	15,69	19,82	23,54	28,26	31,38	39,23	47,07	54,92
3.200	3,35	6,70	8,37	13,40	16,74	20,92	25,10	30,14	33,47	41,84	50,21	58,58
3.500	3,66	7,33	9,15	14,65	18,31	22,89	27,46	32,97	36,61	45,76	54,92	64,07
4.000	4,19	8,37	10,46	16,75	20,92	26,16	31,38	37,68	41,84	52,33	62,76	73,22
4.500	4,70	9,42	11,77	18,84	23,54	29,43	35,30	42,40	47,07	58,84	70,61	82,43
5.000	5,23	10,47	13,08	20,93	26,15	32,70	39,23	47,10	52,33	65,38	78,50	
5.400	5,65	11,30	14,12	22,94	28,24	35,31	42,36	50,67	56,48	70,61	84,78	
6.000	6,28	12,56	15,69	25,12	31,38	39,24	47,07	56,52	62,76	78,50		
7.000	7,33	14,66	18,31	29,31	36,61	45,78	54,92	65,94	73,22	91,58		
8.000	8,37	16,75	20,92	33,94	41,48	52,32	62,76	75,36	83,73			
9.000	9,42	18,84	23,54	37,68	47,07	58,86	70,61	84,78	94,20			
10.000	10,47	20,93	26,17	41,86	52,33	65,40	78,50	94,20				
12.500	13,08	26,17	32,71	52,33	65,42	81,75	98,13					
15.000	15,70	31,40	39,25	62,80								
17.500	18,32	36,63	45,79	73,26								
20.000	20,93	41,87	52,33	83,73								
22.500	23,55	47,10	58,88	94,20								
25.000	26,17	52,33	65,42	104,66								

Oberflächenfinish zu grob:

- Umfangsgeschwindigkeit erhöhen durch größeren Bürstendurchmesser oder höhere Umdrehungszahl (max. UPM beachten).
- Bürste mit größerer Besatzlänge einsetzen.
- Besatz-(Draht- bzw. Borsten-)durchmesser reduzieren.



Bitte beachten Sie:

Alle Personen im Arbeitsbereich müssen Schutzbrille bzw. Gesichtsschutz tragen.

Für untolerierbare Maße gelten unsere allgemeingültigen Toleranzen.

Technical Introduction

KULLEN is the ideal partner when it comes to quality, service and an unsurpassed breadth and depth of product range. We can provide you with a solution to practically all your brush finishing requirements – even for special applications and unusual problems which are perhaps not included in this catalogue. In cases of this kind, and for any questions you may have regarding brush technology or the best way to use brushes, our specialists will be glad to advise you personally. This page gives important technical information of a general nature. Please do not hesitate to contact us directly for advice on special or problem applications.

Brand names and their features:

Record

Brushes filled with crimped wire.

Ultra

Brushes with a twist knot construction.

Multicord

Brushes filled with brass plated steel braided wire.

Delta

Brushes with crimped wire bonded in plastic.

Alpha

Brushes filled with ANDERLON abrasive filaments.

Table of peripheral speeds m/sec.:

Peripheral speed is a decisive factor in achieving optimum performance from a brush, the table opposite will enable you to determine the relevant peripheral speed by simply reading down and across the appropriate diameter and drive shaft operating speed columns. Please note: The operating speed should never exceed the maximum RPM ratings for each brush as shown in this catalogue. In cases where maximum RPM ratings are not indicated and for special brushes which are not listed contact our technical department for guidance. The maximum RPM ratings are safety ratings not recommended operating speeds. The optimum operating speed is determined by the application and in most cases lower operating speeds will prove more efficient and achieve the best result.

As a general guide we recommend the following peripheral speeds when working on the materials listed with:

Record, Multicord and Delta:

Steel – approx. 30 m/sec.

Non-ferrous metals – 18–20 m/sec.

Plastic – approx. 15 m/sec.

Ultra:

Steel – 35–40 m/sec.

Alpha:

Steel – 18–20 m/sec.

Non-ferrous metals – 18–20 m/sec.

Plastic – approx. 15 m/sec.

What to do if the desired brushing effect is not obtained:

Brushing effect too weak:

- Increase the peripheral speed by increasing the brush diameter or the operating speed but never exceed the maximum RPM rating.
- Decrease the trim length.
- Increase the diameter of the fill material.

Brushing effect too powerful:

- Reduce the peripheral speed by reducing the brush diameter or the operating speed.
- Increase the trim length.
- Decrease the diameter of the fill material.

Surface finish too rough:

- Increase the peripheral speed by increasing the brush diameter or the operating speed but never exceed the maximum RPM rating.
- Increase the trim length.
- Decrease the diameter of the fill material.

Surface finish too smooth:

- Reduce the peripheral speed by reducing the brush diameter or the operating speed.
- Decrease the trim length.
- Increase the diameter of the fill material.



All operators and other personnel in areas where brushes are being used must wear safety goggles or face shields.

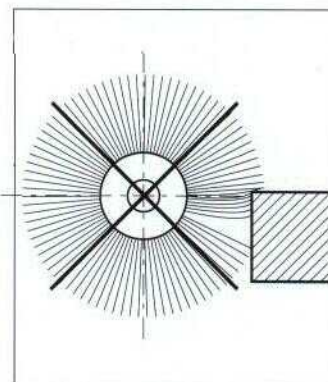

Zu hoher Anpreßdruck (Eintauchtiefe) verringert die Lebensdauer der Bürste.

Excessive operating pressure (penetration depth) will reduce the service life of the brush.

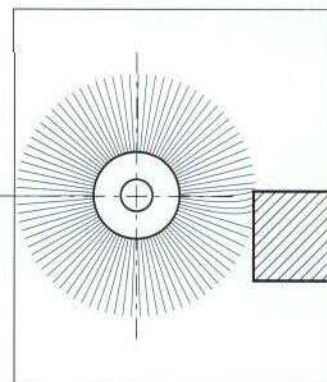

Drahtbürsten arbeiten nur mit den Drahtspitzen. Deshalb genügt meist eine geringe Eintauchtiefe.

Remember only the "tips" of the wire do the work consequently only the lightest possible pressure is required to obtain an effective brushing action.

For all untolerated dimensions our standard tolerances are valid.

Topfbürsten Cup Brushes





**Anwendungen und
Einsatzgebiete
Applications and
purpose** 10

**Topfbürsten
Cup Brushes**
RECORD 12

**Topfbürsten
Cup Brushes**
TS-SPEZIAL/PLUS-ULTRA 14

**Topfbürsten
Cup Brushes**
ULTRA 16

**Kegelscheibenbürsten
Bevel-Brushes**
ULTRA/PLUS-ULTRA/
RECORD/MULTICORD 18

Topfbürsten: Die flexiblen Alleskönner

Sie machen aus einer oxydierten oder beschichteten Metall-Oberfläche ein glanzvolles Meisterstück. Sie sind eben kleine Allrounder auf Winkelschleifern und in Bearbeitungs-Zentren.

Wie das die Topfbürsten von KULLEN machen? Ganz einfach, denn die Lösung liegt in der Natur der Sache: In Rotation spreizt sich der Besatz, die Arbeitsbreite wird größer. Dadurch ist auch eine gründliche Eckenbearbeitung möglich. Die große Anzahl von Besatzspitzen auf der Oberfläche bewirken eine optimale Flächenbearbeitung.

An Metallen erzeugen sie zudem eine ausgezeichnete Oberfläche für Farbgrundierungen oder andere Beschichtungen. Aber das ist noch längst nicht alles – ihre Einsatzgebiete sind sehr vielseitig. Beim Schiffs- und Waggonbau z. B. entrostet oder entlacken sie unter anderem, und bei der Betonfassaden-Renovierung bürsten sie Ablagerungen weg. In der Kfz-Industrie, deren Zulieferer und generell auch in allen Instandhaltungsbetrieben erfüllen sie unzählige Aufgaben. Unentbehrlich sind sie

zum Betonreste Entfernen bei der Schalbrettreinigung, für die Formenreinigung in der Stein-Industrie sowie für die Schweißnahtbearbeitung im Stahlhochbau und in allen metallverarbeitenden Betrieben.

Ausgerüstet mit verschiedenen Anschlußgewinden passen sie hervorragend auf alle elektrischen

und pneumatischen Winkelschleifer. Und als Spezial-Werkzeug in Bearbeitungs-Zentren entgraten sie rationell die unterschiedlichsten Werkstücke.

Erfahrung und Können machen bekanntlich den Meister. Mit dem stärksten Lieferprogramm für technische Bürsten in Europa hat

sich KULLEN diesen Titel verdient. Unsere Topfbürsten sind unter anderem ein Beweis dafür. Probieren Sie sie doch einfach aus.

Für Fragen stehen Ihnen unsere Fachleute gern mit Rat und Tat zur Verfügung. Rufen Sie uns an. Oder schreiben Sie uns.



Topfbürste und Winkelschleifer im Einsatz.

A cup brush and angle grinder at work.

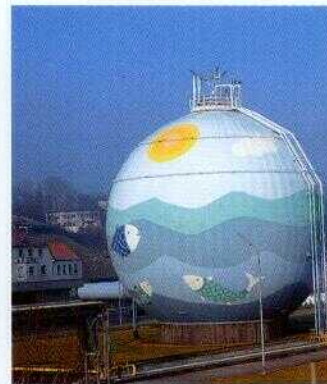

Topfbürsten sorgen für Volumen bei der Schweißnaht-Bearbeitung im Kessel- und Behälterbau.

Cup brushes provide high-volume capacity for the cleaning of welds in boiler-making and tank construction.



Topfbürsten sind ideale Werkzeuge zur Flächenbearbeitung beim modernen Schiffsbau.



Topfbürsten werden höchsten Qualitätsansprüchen gerecht – hier beim Entgraten einer Kurbelwelle.

Cup brushes meet the highest quality requirements – used here to deburr crankshafts.



Topfbürsten erarbeiten die Grundlage für eine individuelle Lackierung – auch im Containerbau.

Cup brushes prepare surfaces prior to painting, as here in container construction.

Cup Brushes: The flexible all-rounders

These brushes can turn an oxidized or coated metal surface into a gleaming masterpiece. These little all-rounders are for use with angle grinders and in automatic finishing and deburring machines.

How do KULLEN cup brushes do this? Easy – the answer is in their

design. During rotation the fill material will splay outwards to transform the large number of abrasive tips into an effective cutting tool which will provide maximum efficiency in use on flat surfaces and into awkward corners to produce an ideal surface finish – for example they will produce an excellent surface on metals for paint

primers or other coatings.

But that is not all – these brushes have countless applications in a variety of industries for example in the building of ships and railway wagons, in the renovation of buildings to clean their facades by brushing away encrustations. In the automobile industry for the finishing

and deburring of components and in every garage workshop for a variety of tasks. In the construction industry they are indispensable for the cleaning of concrete shuttering and all types of metalwork.

They are available with a threaded or plain arbor hole to suit electrical and pneumatic angle grinders.

It's experience and skill that make a champion. With the most powerful line of technical brushes in Europe, KULLEN has earned this title. Our cup brushes are a demonstration of this. Just try them out. If you have any questions, our specialists will naturally be glad to help and advise you. Just give us a call or write.

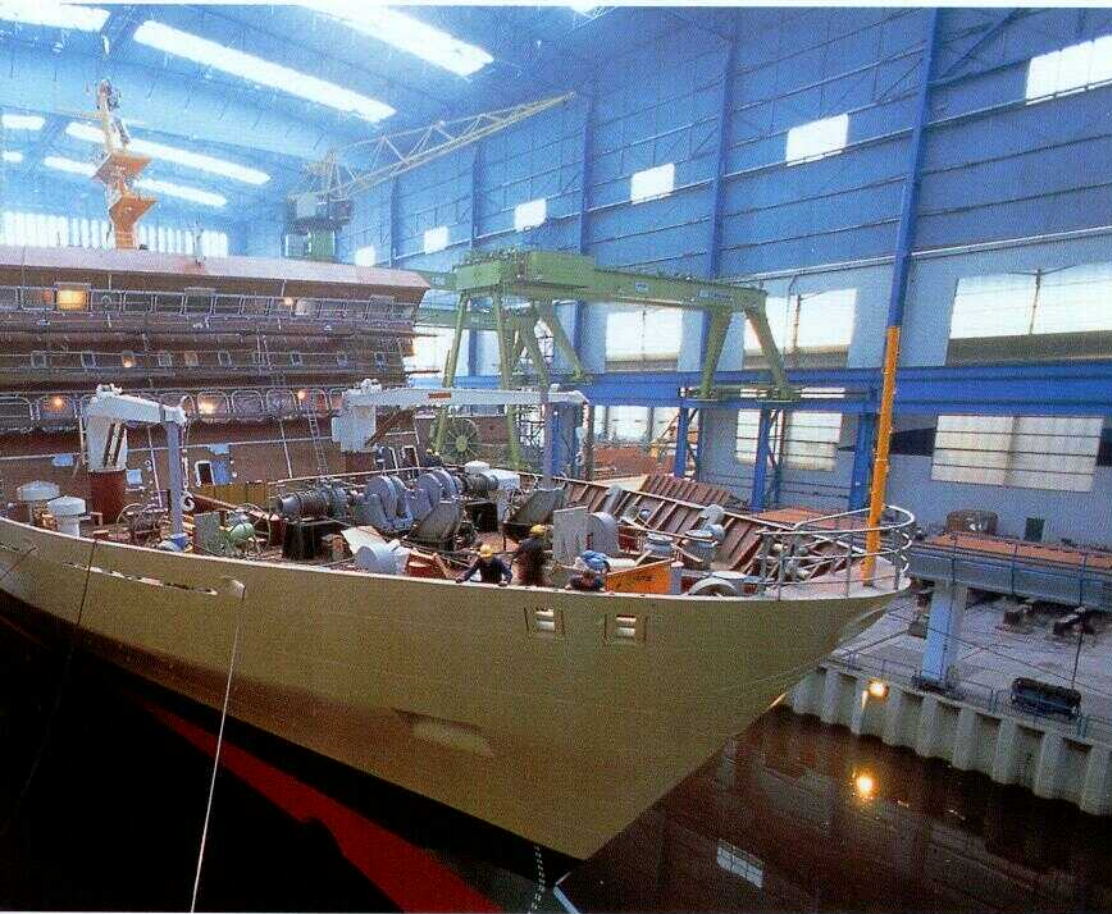

Cup brushes are ideal for the preparation of surfaces in modern shipbuilding.



Topfbürsten in der Kfz-Instandhaltung – die vielseitigen Helfer. *Cup brushes for automobile repairs – the versatile helpers.*

 **Kullen**
Die Welt der Bürstentechnik

Topfbürsten Record

Diese Multitalente mit gewelltem Draht eignen sich hervorragend für Einsätze in stationären Maschinen, Einhandwinkelschleifern, Winkelschleifern und Druckluftschleifern. Passend dazu liefern wir sie mit verschiedenen Aufnahmegewinden.

Besatzarten: RECORD

STD – Stahldraht naturhart, gewellt.

INOX – Stahldraht, nichtrostend und säurebeständig, gewellt.

MES – Messing-Draht (Cu-Zn), gewellt.

Anwendungen:

Zum Entfernen von Rost, Korrosion, Lack und Grundierungen. Und zum Herstellen von reinen Oberflächen.

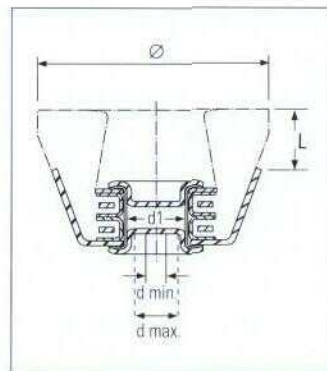

Topfbürsten Record



Wear eye protection!

Cup Brushes Record

Abmessungen/
Dimensions

Ø	L	d	d		UPM/ RPM	Type	0.30 MES	0.20 STD	0.30 STD	0.50 STD
mm	mm	min.	max.		max.		Art.-No.	Art.-No.	Art.-No.	Art.-No.
60 (2 3/8")	18	-	-	M 8	11000	T1.4602	9901.0562	9901.0493	9901.0547	9901.0501
	16	-	-	M 10	11000	T1.6602	9901.0563	9901.0495	9901.0522	9901.0529
	16	-	-	M 12 x 1,5	11000	T1.6602	9901.0230	9901.0494	9901.0027	9901.0515
	16	-	-	M 14	11000	T1.6602	9901.0094	9901.0032	9901.0005	9901.0072
75 (3")	20	-	-	M 14	9000	T1.8752	9901.0141	9901.0074	9901.0516	9901.0158
	20	-	-	Ww 5/8"	9000	T1.8752	9901.0565	9901.0497	9901.0498	9901.0531
80 (3")	25	10	16	d ₁ 20,0	8500	T282	9424.6513	9424.0313	9424.0513	9424.0813
	25	-	-	M 14	8500	T282	9404.6513	9404.0313	9404.0513	9404.0813
	25	-	-	Ww 5/8"	8500	T282	9406.6513	9406.0313	9406.0513	9406.0813
100 (4")	30	10	25	d ₁ 22,2	8500	T3102	9434.6517	9434.0317	9434.0517	9434.0817
	30	-	-	M 14	8500	T3102	9494.6517	9494.0317	9494.0517	9494.0817
	30	-	-	Ww 5/8"	8500	T3102	9496.6517	9496.0317	9496.0517	9496.0817
125 (5")	35	10	32	d ₁ 22,2	6500	T4122	9444.6522	9444.0322	9444.0522	9444.0822
	35	-	-	M 14	6500	T3122	9494.6522	9494.0322	9494.0522	9494.0822
	35	-	-	Ww 5/8"	6500	T3122	9496.6522	9496.0322	9496.0522	9496.0822
150 (6")	55	10	32	d ₁ 22,2	6500	T4152	9444.6527	9444.0327	9444.0527	9444.0827
	55	-	-	M 14	6500	T3152	9494.6527	9494.0327	9494.0527	9494.0827
	55	-	-	Ww 5/8"	6500	T3152	9496.6527	9496.0327	9496.0527	9496.0827

Cup Brushes Record

These multi-purpose brushes with a crimped wire fill are ideally suited for use on bench machines, one-hand angle grinders, large angle grinders and pneumatic grinders. We can supply them with a threaded or plain arbor hole to suit your machine.

Fill types: RECORD

STD – Steel wire, natural hard, crimped.

INOX – Stainless steel wire, acid resistant, crimped.

MES – Brass wire (Cu-Zn), crimped.

Applications:

Removal of rust, corrosion, paint and primer and generally to produce clean surfaces.

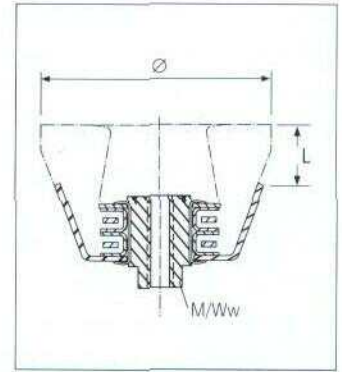

Topfbürsten Record



Wear eye protection!

Cup Brushes Record

Abmessungen/
Dimensions

ø	L	d		Type	UPM/ RPM	Cup Brushes Record			
		min.	max.			0.20 INOX	0.30 INOX	0.50 INOX	
mm	mm				max.	Art.-No.	Art.-No.	Art.-No.	
60 (2 3/8")	18	-	-	M 8	11000	T1.4602	9901.0534	9901.0548	9901.0552
	16	-	-	M 10	11000	T1.6602	9901.0537	9901.0543	9901.0556
	16	-	-	M 12 x 1,5	11000	T1.6602	9901.0536	9901.0021	9901.0555
	16	-	-	M 14	11000	T1.6602	9901.0076	9901.0006	9901.0554
75 (3")	20	-	-	M 14	9000	T1.8752	9901.0540	9901.0071	9901.0558
	20	-	-	Ww 5/8"	9000	T1.8752	9901.0541	9901.0545	9901.0559
80 (3")	25	10	16	d ₁ 20,0	8500	T282	9424.4313	9424.4513	9424.4813
	25	-	-	M 14	8500	T282	9404.4313	9404.4513	9404.4813
	25	-	-	Ww 5/8"	8500	T282	9406.4313	9406.4513	9406.4813
100 (4")	30	10	25	d ₁ 22,2	8500	T3102	9434.4317	9434.4517	9434.4817
	30	-	-	M 14	8500	T3102	9494.4317	9494.4517	9494.4817
	30	-	-	Ww 5/8"	8500	T3102	9496.4317	9496.4517	9496.4817
125 (5")	35	10	32	d ₁ 22,2	6500	T4122	9444.4322	9444.4522	9444.4822
	35	-	-	M 14	6500	T3122	9494.4322	9494.4522	9494.4822
	35	-	-	Ww 5/8"	6500	T3122	9496.4322	9496.4522	9496.4822
150 (6")	55	10	32	d ₁ 22,2	6500	T4152	9444.4327	9444.4527	9444.4827
	55	-	-	M 14	6500	T3152	9494.4327	9494.4527	9494.4827
	55	-	-	Ww 5/8"	6500	T3152	9496.4327	9496.4527	9496.4827

Topfbürsten TS-Spezial und Plus-Ultra

TS-Spezial: Der Stützring dieser speziellen Ausführung verhindert ein extremes Aufspreizen des Besatzes. Fürs Flächenentgraten ist das besonders vorteilhaft, denn so arbeiten mehr Borstenspitzen auf der Oberfläche. Durch Rotation und Oszillation in der Maschine erreicht die TS-Spezial alle Grate.

Besatzarten: TS-SPEZIAL

STD – Stahldraht naturhart, gewellt.

LIT – Stahldraht vermessingt, federhart und zäh, in Seilkonstruktion, gewellt.

ANS – ANDERLON-Schleifborsten mit Silicium-Carbid-Korn, gewellt.

Anwendungen:

Zum Flächenentgraten in CNC-gesteuerten Maschinen.

Plus-Ultra: Im Unterschied zum Typ Ultra (Seite 16) bietet der Typ Plus-Ultra den hochwertigen AZD-Draht und gewährleistet dadurch extrem hohe Standzeiten.

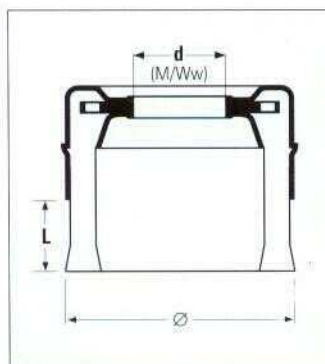

Besatzart: PLUS-ULTRA

AZD – Stahldraht gehärtet, hart und zäh, glatt.

Anwendungen:

Ideal zur Schweißnahtbearbeitung und Schalbrettreinigung.

TS-Spezial ist mit Achsloch und Gewinde lieferbar.

Plus-Ultra nur mit Gewinde.



Ausführung mit Achsloch oder Aufnahme-gewinde erhältlich.

Versions available with a threaded or plain arbor hole.

Topfbürsten TS-Spezial



Wear eye protection!

Cup Brushes TS Special

Abmessungen/ Dimensions		UPM/ RPM		Type	0.30 STD	0.25 LIT	ANS 180/0.90
Ø	L		max.		Art.-No.	Art.-No.	Art.-No.
mm	mm						
70 (2 3/4")	15	M 14	8500	TS72	9909.0059	9909.0062	9909.0065
	15	Ww 5/8"	8500	TS72	9909.0060	9909.0063	9909.0185
	80 (3")	20	d 22,2	8500	TS82	9909.0004	9909.0068
20		M 14	8500	TS82	9909.0008	9909.0021	9909.0070
20		Ww 5/8"	8500	TS82	9909.0067	9909.0069	9909.0071
90 (3 1/2")	20	d 22,2	8500	TS92	9909.0005	9909.0073	9909.0076
	20	M 14	8500	TS92	9909.0009	9909.0074	9909.0029
	20	Ww 5/8"	8500	TS92	9909.0072	9909.0075	9909.0077
100 (4")	20	d 22,2	8500	TS102	9909.0006	9909.0078	9909.0003
	20	M 14	8500	TS102	9909.0010	9909.0079	9909.0081
	20	Ww 5/8"	8500	TS102	9909.0023	9909.0080	9909.0082
120 (4 3/4")	20	d 22,2	6500	TS122	9909.0083	9909.0086	9909.0030
	20	M 14	6500	TS122	9909.0084	9909.0087	9909.0089
	20	Ww 5/8"	6500	TS122	9909.0085	9909.0088	9909.0090
140 (5 1/2")	20	d 22,2	5500	TS142	9909.0176	9909.0024	9909.0114
	20	M 14	5500	TS142	9909.0177	9909.0181	9909.0186
	20	Ww 5/8"	5500	TS142	9909.0178	9909.0182	9909.0187
	20	d 80	5500	TS142	9909.0179	9909.0183	9909.0188

Cup Brushes TS-Special and Plus-Ultra

TS-Special: The support ring of this special design prevents excessive spreading of the fill material. This is especially useful when deburring flat surfaces, since a greater number of bristle tips then act on the workpiece. The TS-Special when used with an orbital action will make

short work of all burrs.

Fill types: TS-SPECIAL

STD – Steel wire, natural hard, crimped.

LIT – Brass plated steel wire, tempered and tough, cord construction, crimped.

ANS – ANDERLON abrasive filaments, silicon-carbide grit, crimped.

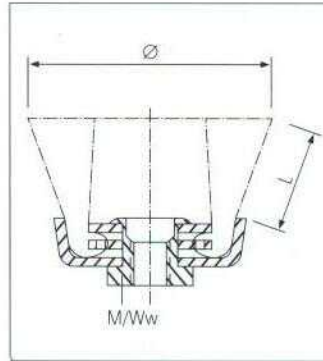

Applications:

For the deburring of surfaces in CNC machines.

Plus-Ultra: In contrast to Ultra (page 16), Plus-Ultra offers highquality AZD wire, ensuring extremely long service life.

Fill type: PLUS-ULTRA

AZD – Steel wire, hardened, high tensile strength and tough, straight.

Applications:

Ideal for cleaning welds and fabricated steelwork.

TS-Special is available with a threaded or plain arbor hole. **Plus-Ultra** with a threaded arbor hole only.



Topfbürsten Plus-Ultra



Wear eye protection!

Cup Brushes Plus-Ultra

Abmessungen/ Dimensions		U _{PM} / RPM		Type	0.35 AZD	0.50 AZD
Ø	L		max.		Art.-No.	Art.-No.
80 (3")	35	M 14	7500	FZ80	9904.9011	9904.9012
	35	Ww 5/8"	7500	FZ80	9904.9013	9904.9014
100 (4")	45	M 14	7500	FZ100A	9904.9015	9904.9040
	45	Ww 5/8"	7500	FZ100A	9904.9018	9904.9041
	35	M 14	7500	FZ100	9904.9021	9904.9022
	35	Ww 5/8"	7500	FZ100	9904.9023	9904.9024

Topfbürsten Ultra

Einzelstehender Zopf, ölschlußgehärteter Draht – das sind die Voraussetzungen, die diese Bürsten besonders aggressiv machen.

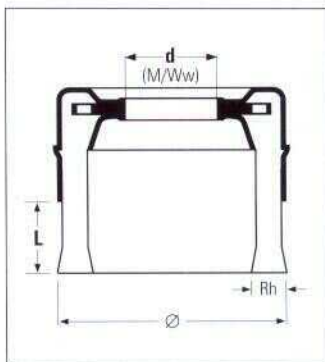

Besatzarten: ULTRA

SUP – Stahldraht gehärtet, glatt.

INOX – Stahldraht, nichtrostend und säurebeständig, glatt.

Anwendungen:

Für schwere Arbeiten wie Entfernen von Lacken, Zunder, Korrosion jeder Art, sowie Bearbeiten von Schweißnähten und -punkten.

Passend für Einhandwinkelschleifer, Winkelschleifer, Druckluftschleifer und stationäre Maschinen.



Topfbürsten Ultra



Wear eye protection!

Cup Brushes Ultra

Abmessungen/
Dimensions

Type
UPM/
RPM

∅	RH	L		max.	Type	0.35 SUP	0.50 SUP	0.80 SUP
mm		mm				Art.-No.	Art.-No.	Art.-No.
65 (2 1/2")	1	20	M 10	12000	TZ61	9904.0029	9904.0032	9904.0251
	1	20	M 14	12000	TZ61	9904.0009	9904.0010	9904.0252
	1	20	Ww 5/8"	12000	TZ61	9904.0017	9904.0018	9904.0253
	1	15	M 14	12000	TZ71	9203.1110	9203.1310	9203.1510
80 (3")	1	25	d 22,2	8500	TZ81	9201.1113	9201.1313	9201.1513
	1	25	M 14	8500	TZ81	9203.1113	9203.1313	9203.1513
	1	25	Ww 5/8"	8500	TZ81	9205.1113	9205.1313	9205.1513
90 (3 1/2")	1	25	d 22,2	8500	TZ91	9201.1115	9201.1315	9201.1515
	1	25	M 14	8500	TZ91	9203.1115	9203.1315	9203.1515
	1	25	Ww 5/8"	8500	TZ91	9205.1115	9205.1315	9205.1515
	2	25	d 22,2	8500	TZ92	9202.1115	9202.1315	9202.1515
100 (4")	2	25	M 14	8500	TZ92	9204.1115	9204.1315	9204.1515
	2	25	Ww 5/8"	8500	TZ92	9206.1115	9206.1315	9206.1515
	1	25	d 22,2	8500	TZ101	9201.1117	9201.1317	9201.1517
	1	25	M 14	8500	TZ101	9203.1117	9203.1317	9203.1517
120 (4 3/4")	1	25	Ww 5/8"	8500	TZ101	9205.1117	9205.1317	9205.1517
	2	25	d 22,2	8500	TZ102	9202.1117	9202.1317	9202.1517
	2	25	M 14	8500	TZ102	9204.1117	9204.1317	9204.1517
	2	25	Ww 5/8"	8500	TZ102	9206.1117	9206.1317	9206.1517
140 (5 1/2")	1	25	d 22,2	6500	TZ121	9201.1121	9201.1321	9201.1521
	1	25	M 14	6500	TZ121	9203.1121	9203.1321	9203.1521
	1	25	Ww 5/8"	6500	TZ121	9205.1121	9205.1321	9205.1521
	2	25	d 22,2	6500	TZ122	9202.1121	9202.1321	9202.1521
	2	25	M 14	6500	TZ122	9204.1121	9204.1321	9204.1521
140 (5 1/2")	2	25	Ww 5/8"	6500	TZ122	9206.1121	9206.1321	9206.1521
	1	25	d 22,2	5500	TZ141	9201.1125	9201.1325	9201.1525
	1	25	M 14	5500	TZ141	9203.1125	9203.1325	9203.1525
	1	25	Ww 5/8"	5500	TZ141	9205.1125	9205.1325	9205.1525
	2	25	d 22,2	5500	TZ142	9202.1125	9202.1325	9202.1525
2	25	M 14	5500	TZ142	9204.1125	9204.1325	9204.1525	
2	25	Ww 5/8"	5500	TZ142	9206.1125	9206.1325	9206.1525	

Mit verschiedenen Aufnahme-
gewinden oder
Achsloch
lieferbar.

Available with
a threaded
or plain
arbor hole.

Cup Brushes Ultra

Single twists, oil-hardened wire – the features which give these brushes their aggressive action.

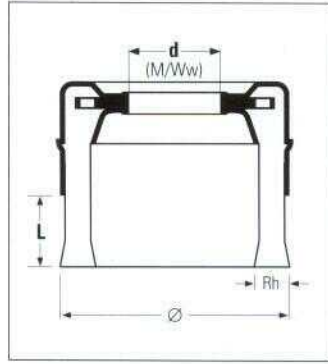

Fill types: ULTRA

SUP – Steel wire, hardened, straight.

INOX – Stainless steel wire, acid resistant, straight.

Applications:

For heavy-duty use such as the removal of paint, scale, corrosion of all kinds and the cleaning of weld seams and spot-welds.

Available to fit one-hand angle grinders, large angle grinders, pneumatic grinders and bench machines.



Topfbürsten Ultra



Wear eye protection!

Cup Brushes Ultra

Abmessungen/
Dimensions

Ø mm	RH	L mm	UPM/ RPM	Type	Cup Brushes Ultra			
					0.35 INOX Art.-No.	0.50 INOX Art.-No.	0.80 INOX Art.-No.	
65 (2 1/2")	1	20	M 10	12000	TZ61	9904.0033	9904.0034	9904.0254
	1	20	M 14	12000	TZ61	9904.0011	9904.0012	9904.0255
	1	20	Ww 5/8"	12000	TZ61	9904.0098	9904.0193	9904.0256
80 (3")	1	15	M 14	12000	TZ71	9203.4110	9203.4310	9203.4510
	1	25	d 22,2	8500	TZ81	9201.4113	9201.4313	9201.4513
	1	25	M 14	8500	TZ81	9203.4113	9203.4313	9203.4513
90 (3 1/2")	1	25	Ww 5/8"	8500	TZ81	9205.4113	9205.4313	9205.4513
	1	25	d 22,2	8500	TZ91	9201.4115	9201.4315	9201.4515
	1	25	M 14	8500	TZ91	9203.4115	9203.4315	9203.4515
100 (4")	1	25	Ww 5/8"	8500	TZ91	9205.4115	9205.4315	9205.4515
	2	25	d 22,2	8500	TZ92	9202.4115	9202.4315	9202.4515
	2	25	M 14	8500	TZ92	9204.4115	9204.4315	9204.4515
	2	25	Ww 5/8"	8500	TZ92	9206.4115	9206.4315	9206.4515
	1	25	d 22,2	8500	TZ101	9201.4117	9201.4317	9201.4517
	1	25	M 14	8500	TZ101	9203.4117	9203.4317	9203.4517
120 (4 3/4")	1	25	Ww 5/8"	8500	TZ101	9205.4117	9205.4317	9205.4517
	2	25	d 22,2	8500	TZ102	9202.4117	9202.4317	9202.4517
	2	25	M 14	8500	TZ102	9204.4117	9204.4317	9204.4517
	2	25	Ww 5/8"	8500	TZ102	9206.4117	9206.4317	9206.4517
	1	25	d 22,2	6500	TZ121	9201.4121	9201.4321	9201.4521
	1	25	M 14	6500	TZ121	9203.4121	9203.4321	9203.4521
140 (5 1/2")	1	25	Ww 5/8"	6500	TZ121	9205.4121	9205.4321	9205.4521
	2	25	d 22,2	6500	TZ122	9202.4121	9202.4321	9202.4521
	2	25	M 14	6500	TZ122	9204.4121	9204.4321	9204.4521
	2	25	Ww 5/8"	6500	TZ122	9206.4121	9206.4321	9206.4521
	1	25	d 22,2	5500	TZ141	9201.4125	9201.4325	9201.4525
	1	25	M 14	5500	TZ141	9203.4125	9203.4325	9203.4525
140 (5 1/2")	1	25	Ww 5/8"	5500	TZ141	9205.4125	9205.4325	9205.4525
	2	25	d 22,2	5500	TZ142	9202.4125	9202.4325	9202.4525
	2	25	M 14	5500	TZ142	9204.4125	9204.4325	9204.4525
	2	25	Ww 5/8"	5500	TZ142	9206.4125	9206.4325	9206.4525

Mit verschiedenen Aufnahme-gewinden oder Achsloch lieferbar.

Available with a threaded or plain arbor hole.

Kegelscheibenbürsten Ultra/Plus-Ultra/Record/Multicord

Kegelscheibenbürsten sind eine gelungene Mischung aus Rund- und Topfbürsten. Sie wurden von uns eigens für die Bearbeitung von Kanten und Ecken schwer zugänglicher Arbeitsbereiche entwickelt. Vier Typen können wir Ihnen davon anbieten: Die Ultra und Plus-Ultra in der gezopften Ausführung. Die Record mit ihrem gewellten und die Multicord mit ihrem geseilten Stahldraht. Mehr darüber in der Besatzarten-Beschreibung.

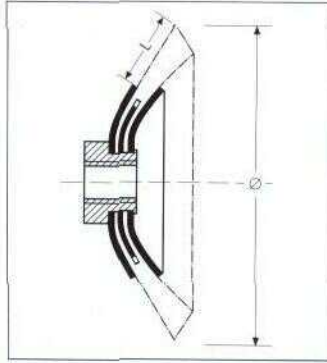

PLUS-ULTRA

AZD – Stahldraht gehärtet, hart und zäh, glatt.

RECORD

STD – Stahldraht naturhart, gewellt.

INOX – Stahldraht, nichtrostend und säurebeständig, gewellt.

MULTICORD

LIT – Stahldraht vermessingt, federhart, zäh, in Seilkonstruktion, gewellt.

Anwendungen:

Für schwere Arbeiten wie Entfernen von Lacken, Zunder und Korrosion jeder Art. Durch ihre Form speziell für die Innenkanten-Bearbeitung auf dem Einhand- und Winkelschleifer geeignet.

Mit passendem Aufnahme-gewinde für Einhand- und Winkelschleifer.

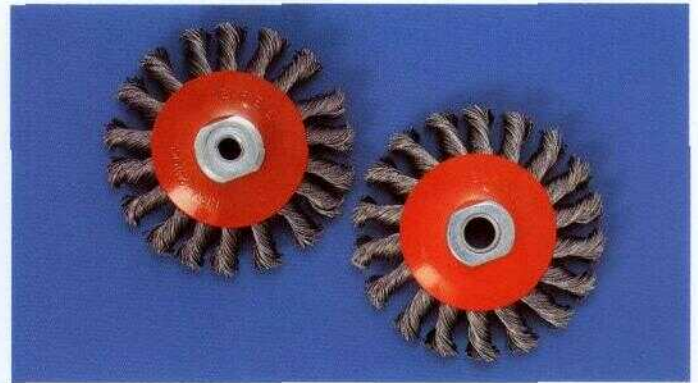

Besatzarten: ULTRA

SUP – Stahldraht gehärtet, glatt.

INOX – Stahldraht, nichtrostend und säurebeständig, glatt.

Kegelscheibenbürsten Ultra



Wear eye protection!

Bevel-Brushes Ultra

Abmessungen/ Dimensions			UPM/ RPM	Type								
∅	ZR*	RH	L			0.35 SUP	0.50 SUP	0.80 SUP	0.35 INOX	0.50 INOX	0.80 INOX	
mm			mm	max.	Art.-No.	Art.-No.	Art.-No.	Art.-No.	Art.-No.	Art.-No.	Art.-No.	
100 (4")	R	1	20	M 14	12500	FZ100F	9904.9511	9904.9500	9904.9521	9904.9512	9904.9501	9904.9522
100 (4")	L	1	20	M 14	12500	FZ100F	9904.9528	9904.9524	9904.9529	9904.9530	9904.9531	9904.9532
115 (4 1/2")	R	1	27,5	M 14	12500	FZ115F	9904.9533	9904.9519	9904.9534	9904.9535	9904.9536	9904.9537
115 (4 1/2")	L	1	27,5	M 14	12500	FZ115F	9904.9538	9904.9507	9904.9539	9904.9540	9904.9508	9904.9541
178 (7")	L	1	30,5	M 14	9000	FZ178F	9904.9552	9904.9042	9904.9553	9904.9554	9904.9555	9904.9556

ZR* = Zopfrichtung / knot-direction: R = rechts / righthand, L = links / lefthand

Kegelscheibenbürsten Plus-Ultra



Wear eye protection!

Bevel-Brushes Plus-Ultra

Abmessungen/ Dimensions			UPM/ RPM	Type				
∅	ZR*	RH	L		0.35 AZD	0.50 AZD		
mm			mm	max.	Art.-No.	Art.-No.		
100 (4")	R	1	20	M 14	12500	FZ100F	9904.9513	9904.9514
100 (4")	L	1	20	M 14	12500	FZ100F	9904.9542	9904.9543
115 (4 1/2")	R	1	27,5	M 14	12500	FZ115F	9904.9544	9904.9545
115 (4 1/2")	L	1	27,5	M 14	12500	FZ115F	9904.9546	9904.9547
178 (7")	L	1	30,5	M 14	9000	FZ178F	9904.9557	9904.9558

ZR* = Zopfrichtung / knot-direction: R = rechts / righthand, L = links / lefthand

Bevel-Brushes Ultra/Plus-Ultra/Record/Multicord

Bevel-brushes are an ingenious combination of circular and cup brushes. We have developed these specially for work in hard-to-reach places such as edges and corners. We offer four types – Ultra and Plus-Ultra with twisted wire, Record with crimped wire and Multicord with

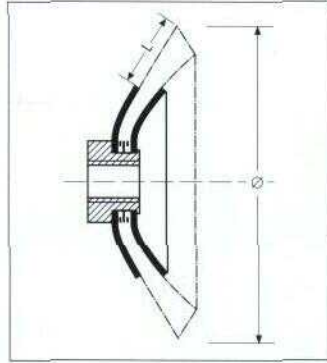

steel cable wire. See the description of fill materials for details.

Fill types: ULTRA

SUP – Steel wire, hardened, straight.

INOX – Stainless steel wire, acid resistant, straight.

PLUS-ULTRA

AZD – Steel wire, hardened, high

tensile strength and tough, straight.

RECORD

STD – Steel wire, natural hard, crimped.

INOX – Stainless steel wire, acid resistant, crimped.

MULTICORD

LIT – Brass plated steel wire, tempered and tough, cord construction, crimped.



Applications:

Heavy-duty work such as the removal of paint, scale and corrosion of all kinds. Design particularly suitable for work on internal corners, using a one-hand and large angle grinder.

Available with thread to fit one-hand and large angle grinders.

Kegelscheibenbürsten Record



Wear eye protection!

Bevel-Brushes Record

Abmessungen/ Dimensions		UPM/ RPM		Type	0.20 STD	0.30 STD	0.20 LTE	0.30 LTE	0.20 INOX	0.30 INOX	
φ	RH	L	max.		Art.-No.	Art.-No.	Art.-No.	Art.-No.	Art.-No.	Art.-No.	
100 (4")	2	20	M 14	12000	F100F	9901.9500	9901.9501	9901.9503	9901.9504	9901.9505	9901.9506

Kegelscheibenbürsten Multicord



Wear eye protection!

Bevel-Brushes Multicord

Abmessungen/ Dimensions		UPM/ RPM		Type	0.15 LIT	0.20 LIT	0.27 LIT	
φ	RH	L	max.		Art.-No.	Art.-No.	Art.-No.	
100 (4")	2	20	M 14	12000	MC-F100F	9901.9507	9901.9508	9901.9502

Schaftbürsten

Shaft-Mounted Brushes



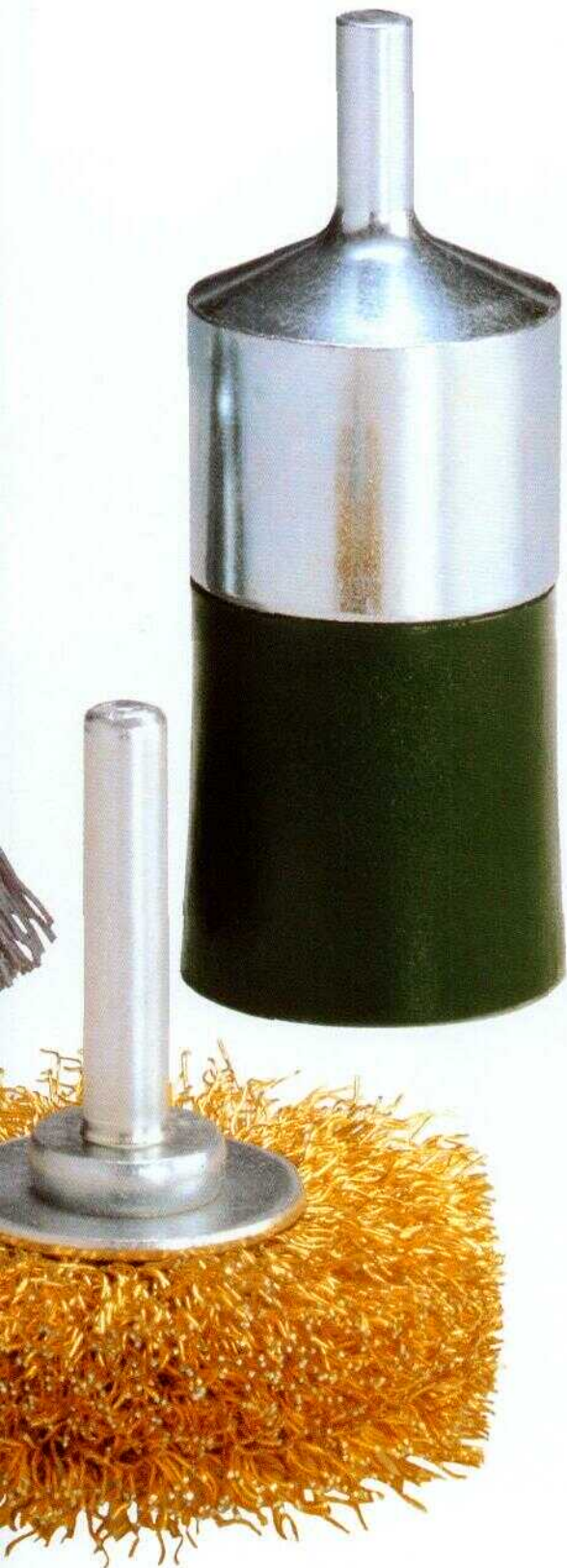

Anwendungen und Einsatzgebiete Applications and purpose	22
--	----

Schaftrundbürsten Shaft-Mounted Circular Brushes	
RECORD	24

Schaftrundbürsten Shaft-Mounted Circular Brushes	
MULTICORD/ MULTICORD SPEZIAL/ RECORD SPEZIAL	26

Schaftrundbürsten Shaft-Mounted Circular Brushes	
DELTA/ULTRA/ALPHA/ ALPHA SPEZIAL	28

Schafttopfbürsten Shaft-Mounted Cup Brushes	
RECORD/ALPHA	30

Pinselbürsten End Brushes	
RECORD/ALPHA	32

Pinselbürsten End Brushes	
MULTICORD/DELTA/ PLUS-ULTRA	34

Schaftbürsten: Die Kraftvollen mit Stil

Sie sind die „ambulanten“ Bürsten für schwierige Einsätze. Sie werden überall da gebraucht, wo mit Elektro- und Druckluftwerkzeugen gearbeitet wird. Und sie rekrutieren sich aus drei Bürstenarten: Topfbürsten, Rundbürsten und Pinselbürsten.

Der Schaft macht den Unterschied. Mit ihm wird eine normale Topf- oder Rundbürste zur Schaftbürste. Pinselbürsten gibt es sowieso nur mit Schaft. Bei allen fungiert er als Aufnahme in Elektro- oder Druckluft-Werkzeugen und in biegsamen Wellen, oder auch in Bearbeitungszentren. Hier kommen Schaftbürsten zum Einsatz: sie sind unersetzlich im Karosserie- und Motorenbau sowie überaus vielseitig für Kfz-Reparatur und Instandhaltung. Sie sind generell nicht wegzudenken aus diversen Instandhaltungsbetrieben und äußerst praktisch beim Maschinen-, Schiffs- und Waggonbau. Besonders wichtig sind sie in

der Flugzeug-Industrie und absolut unentbehrlich als Zubehör für Elektro- und Druckluftwerkzeuge. In diesem Prospekt finden Sie unser komplettes Standardprogramm. Auf Anfrage erhalten Sie auch Sonderausführungen.

Übrigens: Wir empfehlen bei Stahl eine Umfangsgeschwindigkeit von

30/40 m/sec, bei NE-Metall 18/20 m/sec und bei Kunststoff 10/15 m/sec.

Wenn Sie jetzt Fragen haben, stehen Ihnen selbstverständlich unsere Spezialisten mit Rat und Tat zur Verfügung – sie haben entscheidend daran mitgewirkt, daß KULLEN das größte Lieferprogramm

technischer Bürsten in Europa hat, und kennen auch für Ihr Problem eine Lösung.

Rufen Sie uns an. Oder schreiben Sie uns. Wir helfen Ihnen gern weiter.



Entfernen von Unterbodenschutz mit einer Ultra Schafrundbürste.

Removing underseal with a Ultra shaft-mounted circular brush.

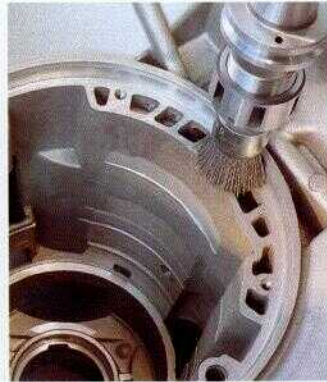

Stirnflächen-Entgraten an einem Getriegehäuse mit einer Alpha Pinselbürste.

Deburring the end faces of a gearbox housing with an Alpha end brush.



Schaftbürsten machen das Rennen in Kfz-Industrie und -Instandhaltung.



Innenbearbeitung eines Ventilkörpers mit einer Pinselbürste Type G.

Working on the inside of a valve body with an End Brush Type G.

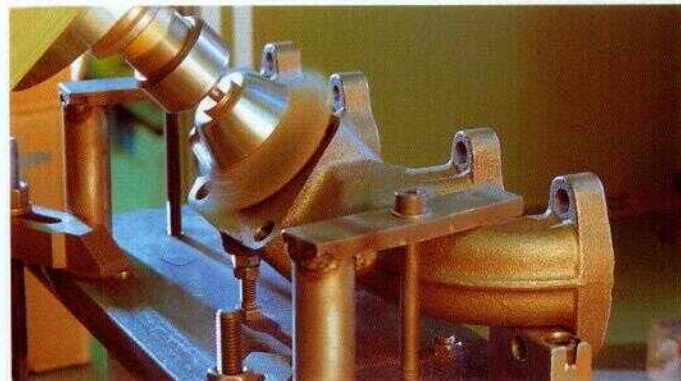

Stirnflächen-Entgraten an einem Fächerkrümmer mit einer Record Schafttopfbürste.

Deburring the end faces of a manifold with a Record shaft-mounted cup brush.

Shaft-Mounted Brushes: Power and style

These are the "versatile" brushes for tough conditions. They are used wherever electrical and pneumatic tools are at work. And they offer a choice of three types of brushes – cup brushes, circular brushes and end brushes.

The shaft does make a difference. It gives an added dimension to a standard cup or circular brush providing a simple fixing arrangement to any portable or automatic machine.

Shaft-mounted brushes are indispensable in the manufacture of vehicle bodywork, engines,

machines, ships, railway wagons etc. and are particularly important in the aircraft industry. In fact almost all applications where portable power tools are used the shaft-mounted brush could prove a useful accessory. This brochure shows our complete standard range. Special versions are available on request.

By the way: We recommend a peripheral speed of 30–40 m/sec. for steel, 18–20 m/sec. for non-ferrous metals and 10–15 m/sec. for plastic.

If you have any questions, our specialists will naturally be glad to assist and advise you – they have played a large part in making KULLEN products into the most powerful line of technical brushes in Europe and are sure to have the solution to your problem. Just give us a call or write. We will be happy to help.



Shaft-mounted brushes are the favourites in automobile manufacture and repair.



Schweißnahtbearbeitung mit einer Delta Schafrundbürste.

Working on welds with a Delta shaft-mounted circular brush.

Die Welt der Bürstentechnik

Schaftrundbürsten Record

Record Schaftrundbürsten werden mit gewellten Drähten in verschiedenen Qualitäten gefertigt. Sie sind ideal für den Einsatz in Bohrmaschinen, biegsamen Wellen, Druckluftschleifern und stationären Maschinen.

Besatzarten: RECORD

STD – Stahldraht naturhart, gewellt.

INOX – Stahldraht, nichtrostend und säurebeständig, gewellt.

MES – Messing-Draht (Cu-Zn), gewellt.

Anwendungen:

Bearbeitung verschiedenster Oberflächen, speziell an schwer zugänglichen Stellen. Zum Glätten, Verputzen von Gußnähten und Gummi-Metalteilen, für leichte Entgratarbeiten und zum Entfernen von Korrosion und von Lacken.

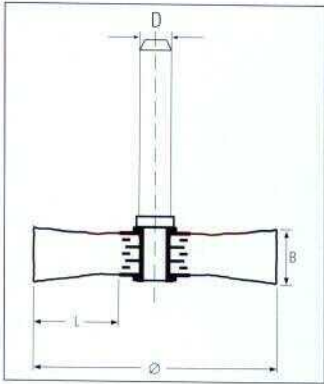

Schaftrundbürsten Record



Wear eye protection!

Shaft-Mounted Circular Brushes Record

Abmessungen/ Dimensions				UPM/ RPM	Type				
Ø	B	L	D			0.15 STD	0.20 STD	0.30 STD	0.50 STD
mm	mm	mm	mm	max.	Art.-No.	Art.-No.	Art.-No.	Art.-No.	
20 (3/4")	4	3	6	20000	03202 S	9532.0220	9532.0320	-	-
30 (1 1/4")	6	6,5	6	20000	05302 S	9552.0230	9552.0330	9552.0530	9552.0830
	9	6,5	6	20000	05303 S	9553.0230	9553.0330	9553.0530	9553.0830
	12	6,5	6	20000	05304 S	9554.0230	9554.0330	9554.0530	9554.0830
40 (1 1/2")	9	9	6	18000	08402 S	9582.0240	9582.0340	9582.0540	9582.0840
	13,5	9	6	18000	08403 S	9583.0240	9583.0340	9583.0540	9583.0840
	18	9	6	18000	08404 S	9584.0240	9584.0340	9584.0540	9584.0840
50 (2")	10	12,5	6	15000	08502 S	9582.0250	9582.0350	9582.0550	9582.0850
	15	12,5	6	15000	08503 S	9583.0250	9583.0350	9583.0550	9583.0850
	20	12,5	6	15000	08504 S	9584.0250	9584.0350	9584.0550	9584.0850
60 (2 3/8")	10	17,5	6	15000	08602 S	9582.0260	9582.0360	9582.0560	9582.0860
	15	17,5	6	15000	08603 S	9583.0260	9583.0360	9583.0560	9583.0860
	20	17,5	6	15000	08604 S	9584.0260	9584.0360	9584.0560	9584.0860
70 (2 3/4")	10	19	6	15000	08702 S	9582.0270	9582.0370	9582.0570	9582.0870
	15	19	6	15000	08703 S	9583.0270	9583.0370	9583.0570	9583.0870
	20	19	6	15000	08704 S	9584.0270	9584.0370	9584.0570	9584.0870
80 (3")	10	19	6	12000	08802 S	9582.0280	9582.0380	9582.0580	9582.0880
	15	19	6	12000	08803 S	9583.0280	9583.0380	9583.0580	9583.0880
	20	19	6	12000	08804 S	9584.0280	9584.0380	9584.0580	9584.0880

Shaft-Mounted Circular Brushes Record

Record shaft-mounted circular brushes are produced from crimped wire in various qualities. They are ideal for use in power drills, on flexible shafts, in pneumatic grinders and in bench machines.

Fill types: RECORD

STD – Steel wire, natural hard, crimped.

INOX – Stainless steel wire, acid resistant, crimped.

MES – Brass wire (Cu-Zn), crimped.

Applications:

Preparation of all kinds of surfaces, especially at hard-to-reach areas.

For smoothing, trimming of casting joints and rubber to metal bonded parts, light deburring work and the removal of corrosion and paint.

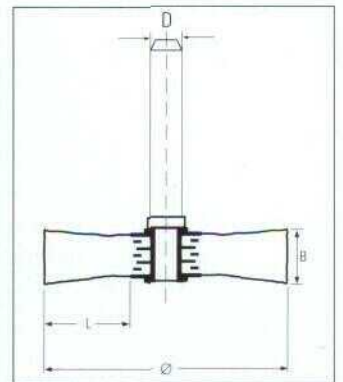

Schaftrundbürsten Record



Shaft-Mounted Circular Brushes Record

Abmessungen/
Dimensions:

UPM/
RPM

Ø	B	L	D	max.	Type	0.20 INOX	0.30 INOX	0.20 MES	0.30 MES
mm	mm	mm	mm			Art.-No.	Art.-No.	Art.-No.	Art.-No.
20 (3/4")	4	3	6	20000	03202 S	9532.4320	-	9532.6320	-
30 (1 1/4")	6	6,5	6	20000	05302 S	9552.4330	9552.4530	9552.6330	9552.6530
	9	6,5	6	20000	05303 S	9553.4330	9553.4530	9553.6330	9553.6530
	12	6,5	6	20000	05304 S	9554.4330	9554.4530	9554.6330	9554.6530
40 (1 1/2")	9	9	6	18000	08402 S	9582.4340	9582.4540	9582.6340	9582.6540
	13,5	9	6	18000	08403 S	9583.4340	9583.4540	9583.6340	9583.6540
	18	9	6	18000	08404 S	9584.4340	9584.4540	9584.6340	9584.6540
50 (2")	10	12,5	6	15000	08502 S	9582.4350	9582.4550	9582.6350	9582.6550
	15	12,5	6	15000	08503 S	9583.4350	9583.4550	9583.6350	9583.6550
	20	12,5	6	15000	08504 S	9584.4350	9584.4550	9584.6350	9584.6550
	60 (2 3/8")	10	17,5	6	15000	08602 S	9582.4360	9582.4560	9582.6360
15		17,5	6	15000	08603 S	9583.4360	9583.4560	9583.6360	9583.6560
20		17,5	6	15000	08604 S	9584.4360	9584.4560	9584.6360	9584.6560
70 (2 3/4")	10	19	6	15000	08702 S	9582.4370	9582.4570	9582.6370	9582.6570
	15	19	6	15000	08703 S	9583.4370	9583.4570	9583.6370	9583.6570
	20	19	6	15000	08704 S	9584.4370	9584.4570	9584.6370	9584.6570
80 (3")	10	19	6	12000	08802 S	9582.4380	9582.4580	9582.6380	9582.6580
	15	19	6	12000	08803 S	9583.4380	9583.4580	9583.6380	9583.6580
	20	19	6	12000	08804 S	9584.4380	9584.4580	9584.6380	9584.6580

Schaftrundbürsten Multicord/Multicord Spezial/Record Spezial

Multicord: Eine Type, die durch die Seilkonstruktion der Drähte noch aggressiver wird.

Besatzart: MULTICORD

LIT – Stahldraht vermessingt, federhart und zäh, in Seilkonstruktion, gewellt.

Anwendungen:

Für die Oberflächenbearbeitung an schwer zugänglichen Stellen. Zum Verputzen von Gußnähten und Gummi-Metalteilen, für leichte Entgratarbeiten und zum Entfernen von Korrosion und von Lacken.

Multicord Spezial/Record Spezial: Der Besatz wird bei

diesen Typen extrem fest fixiert – daraus resultiert eine erhöhte Aggressivität und eine schmale Arbeitsbreite.

Besatzarten:

MULTICORD SPEZIAL

LIT – Stahldraht vermessingt, federhart und zäh, in Seilkonstruktion, gewellt.

RECORD SPEZIAL

STD – Stahldraht naturhart, gewellt.
LTE – Stahldraht vermessingt, Einzeldraht, federhart, gewellt.

Anwendungen:

Beide: Zur Bearbeitung von schwer zugänglichen Bereichen wie Innenkanten, Nuten und Ritzen – speziell im Karosseriebau.

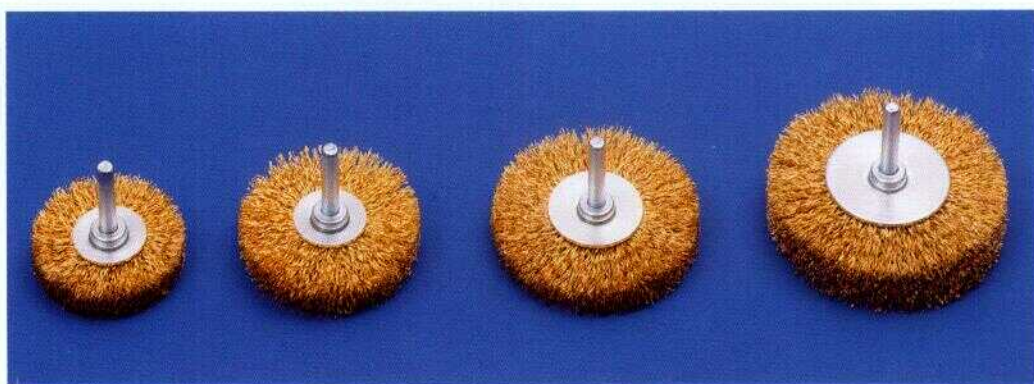
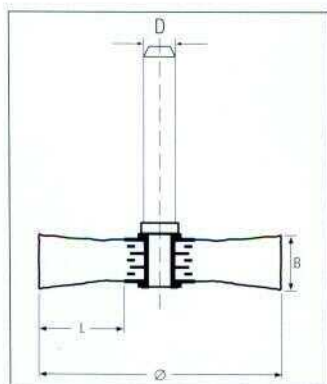

Schaftrundbürsten Multicord



Wear eye protection!

Shaft-Mounted Circular Brushes Multicord

Abmessungen/ Dimensions	B	L	D	UPM/ RPM	Type	0.25 LIT
Ø	mm	mm	mm	max.		Art.-No.
50 (2")	10	12,5	6	15000	MC-08502 S	9582.7850
	15	12,5	6	15000	MC-08503 S	9583.7850
	20	12,5	6	15000	MC-08504 S	9584.7850
60 (2 3/8")	10	17,5	6	15000	MC-08602 S	9582.7860
	15	17,5	6	15000	MC-08603 S	9583.7860
	20	17,5	6	15000	MC-08604 S	9584.7860
70 (2 3/4")	10	19	6	15000	MC-08702 S	9582.7870
	15	19	6	15000	MC-08703 S	9583.7870
	20	19	6	15000	MC-08704 S	9584.7870
80 (3")	10	19	6	12000	MC-08802 S	9582.7880
	15	19	6	12000	MC-08803 S	9583.7880
	20	19	6	12000	MC-08804 S	9584.7880

Shaft-Mounted Circular Brushes Multicord/Multicord Special/Record Special

Multicord: The cable-type wires of this brush make its action even more aggressive.

Fill type: MULTICORD

LIT – Brass plated steel wire, tempered and tough, cord construction, crimped.

Applications:

For surface preparation of hard-to-reach areas. For trimming of casting joints and rubber to metal bonded parts, light deburring work and the removal of corrosion and paint.

Multicord Special/Record Special: These types of brushes feature extremely

heavy-duty anchoring of the fill material, which gives them an even more aggressive action and a narrow working width.

Fill types: MULTICORD SPECIAL

LIT – Brass plated steel wire, tempered and tough, cord construction, crimped.

RECORD SPECIAL

STD – Steel wire, natural hard, crimped.

LTE – Brass plated steel wire, tempered, single-wire, crimped.

Applications:

Both types: Are ideal for brushing hard-to-reach areas such as internal edges, grooves and gaps, particularly on vehicle bodywork.

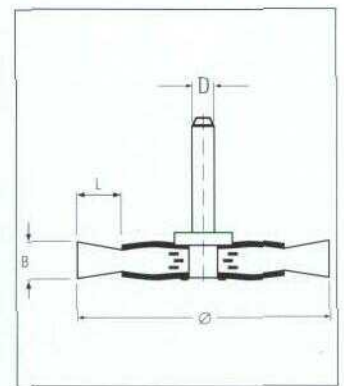

Schaftrundbürsten Record Spezial



Wear eye protection!

Shaft-Mounted Circular Brushes Record Special

Abmessungen/
Dimensions

Ø	B	L	D	UPM/ RPM	Type				
						0.30 LTE	0.30 STD	0.40 STD	0.50 STD
mm	mm	mm	mm	max.	Art.-No.	Art.-No.	Art.-No.	Art.-No.	
55 (2 1/8")	8	15	6	15000	D08552 S	9592.5555	9592.0555	9592.0755	9592.0855
60 (2 3/8")	12	18	6	15000	D08603 S	9593.5560	9593.0560	9593.0755	9593.0855
70 (2 3/4")	4	15	6	15000	D1701 S	9521.5570	9521.0570	9521.0770	9521.0870
	8	15	6	15000	D1702 S	9522.5570	9907.0512	9522.0770	9907.0502

Schaftrundbürsten Multicord Spezial



Wear eye protection!

Shaft-Mounted Circular Brushes Multicord Special

Abmessungen/
Dimensions

Ø	B	L	D	UPM/ RPM	Type	
						0.25 LIT
mm	mm	mm	mm	max.	Art.-No.	
55 (2 1/8")	8	15	6	15000	D08552 S	9592.7855
70 (2 3/4")	8	15	6	15000	D1702 S	9907.0549

Schaftrundbürsten Delta/Ultra/Alpha/Alpha Spezial

Delta: In eine elastische Kunststoffmasse eingebettet, sind die Drähte extrem aggressiv und gewährleisten hohe Standzeiten.

Besatzart: DELTA

LTE – Stahldraht vermessingt, Einzeldraht, federhart, gewellt.

Anwendungen: Zum Bearbeiten von Schweißnähten und -punkten. Zum Entfernen von Zunderschichten.

Ultra: Einzelstehender Zopf, ölschlußgehärteter Draht – die Voraussetzungen für hohe Aggressivität.

Besatzarten: ULTRA

SUP – Stahldraht gehärtet, glatt.

INOX – Stahldraht, nichtrostend und säurebeständig, glatt.

Anwendungen: Zum Bearbeiten von Schweißnähten und -punkten. Zum Entfernen von zähen Massen (z. B. Unterbodenschutz), von Dichtungs-Massen oder Kleberesten.

Alpha/Alpha Spezial: Eine hitzestabilisierte Polyamid-Borste mit 20–40 % Schleifkörnern angereichert.

Die Spezial-Version ist eine extra schmale und kompakte Ausführung.

Besatzarten:

ALPHA/ALPHA SPEZIAL

ANS – ANDERLON-Schleifborsten mit Silicium-Carbid-Korn, gewellt.

Anwendungen: Für vielfältige Entgrat-Arbeiten – auch in Bearbeitungs-Zentren.

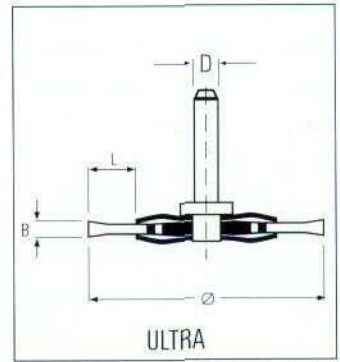

Schaftrundbürsten Delta



Wear eye protection!

Shaft-Mounted Circular Brushes Delta

Abmessungen/
Dimensions:

Ø	B	L	D	UPM/ RPM	Type				
						0.15 LTE	0.20 LTE	0.30 LTE	0.35 LTE
mm	mm	mm	mm	max.	DK-SH301 S	Art.-No.	Art.-No.	Art.-No.	Art.-No.
30 (1 1/4")	7	6	6	20000	DK-SH301 S	9918.5005	9918.5010	9918.5015	9918.5020
40 (1 1/2")	7	11	6	20000	DK-SH401 S	9918.5006	9918.5011	9918.5016	9918.5021
50 (2")	7	14	6	15000	DK-SH501 S	9918.5007	9918.5012	9918.5017	9918.5022
63 (2 1/2")	7	20	6	15000	DK-SH631 S	9918.5008	9918.5013	9918.5018	9918.5003
75 (2 7/8")	7,4	24	6	15000	DK-SH751 S	9918.5009	9918.5014	9918.5019	9918.5023

Schaftrundbürsten Ultra



Wear eye protection!

Shaft-Mounted Circular Brushes Ultra

Abmessungen/
Dimensions:

Ø	Z*	B	L	D	UPM/ RPM	Type				
							0.30 SUP	0.50 SUP	0.35 INOX	0.50 INOX
mm		mm	mm	mm	max.	ZK 1701 S	Art.-No.	Art.-No.	Art.-No.	Art.-No.
70 (2 3/4")	15	6	15	6	20000	ZK 1701 S	9902.1001	9902.1004	9902.1068	9902.1070
	15	15	15	6	20000	ZK 1702 S	9902.1072	9902.1008	9902.1069	–

Z* = Anzahl der Zöpfe pro Reihe/Numbers of knots per row

Shaft-Mounted Circular Brushes Delta/Ultra/Alpha/Alpha Special

Delta: Embedded in flexible plastic, the wires of these brushes offer an extremely aggressive action and long service life.

Fill type: DELTA

LTE – Brass plated steel wire, tempered, single-wire, crimped.

Applications: Working on weld seams and spot-welds. Removal of hard scale.

Ultra: Twist knot construction and oil-hardened wire – the prerequisites for a powerful aggressive action.

Fill types: ULTRA

SUP – Steel wire, hardened, straight.

INOX – Stainless steel wire, acid resistant, straight.

Applications: Working on weld seams and spot-welds. Removal of tough compounds (e.g. underseal), sealing compounds and stubborn adhesive residues.

Alpha/Alpha Special: Heat-resistant polyamide filaments impregnated with 20–40%

abrasive grit. The “Special” version is ultra-slim and compact.

Fill type: ALPHA/ALPHA SPECIAL
ANS – ANDERLON abrasive filaments, silicon-carbide grit, crimped.

Applications: For many kinds of deburring work, for hand held or automatic machines.

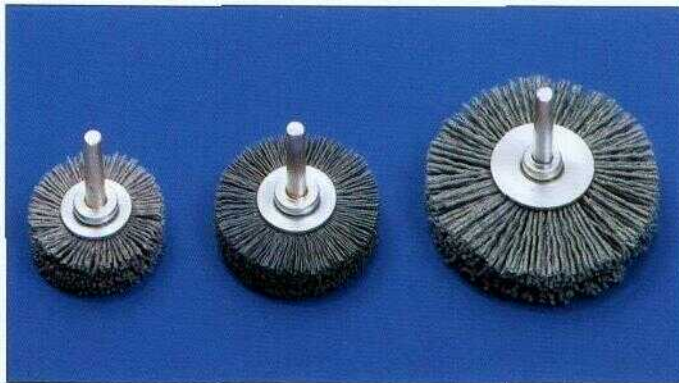

Schaftrundbürsten Alpha



Shaft-Mounted Circular Brushes Alpha

Abmessungen/
Dimensions

UPM/
RPM

Type

ANS 320/0.55 **ANS 180/0.90** **ANS 120/1.00**

∅	B	L	D	max.	Type	ANS 320/0.55 Art.-No.	ANS 180/0.90 Art.-No.	ANS 120/1.00 Art.-No.
40 (1 1/2")	9	9	6	18000	AS-08402 S	9582.9740	9582.9840	9582.9940
	13,5	9	6	18000	AS-08403 S	9583.9740	9583.9840	9583.9940
	18	9	6	18000	AS-08404 S	9584.9740	9584.9840	9584.9940
50 (2")	10	12,5	6	15000	AS-08502 S	9582.9750	9582.9850	9582.9950
	15	12,5	6	15000	AS-08503 S	9583.9750	9583.9850	9583.9950
	20	12,5	6	15000	AS-08504 S	9584.9750	9584.9850	9584.9950
60 (2 3/8")	10	17,5	6	15000	AS-08602 S	9582.9760	9582.9860	9582.9960
	15	17,5	6	15000	AS-08603 S	9583.9760	9583.9860	9583.9960
	20	17,5	6	15000	AS-08604 S	9584.9760	9584.9860	9584.9960
70 (2 3/4")	10	19	6	15000	AS-08702 S	9582.9770	9582.9870	9582.9970
	15	19	6	15000	AS-08703 S	9583.9770	9583.9870	9583.9970
	20	19	6	15000	AS-08704 S	9584.9770	9584.9870	9584.9970
80 (3")	10	19	6	12000	AS-08802 S	9582.9780	9582.9880	9582.9980
	15	19	6	12000	AS-08803 S	9583.9780	9583.9880	9583.9980
	20	19	6	12000	AS-08804 S	9584.9780	9584.9880	9584.9980

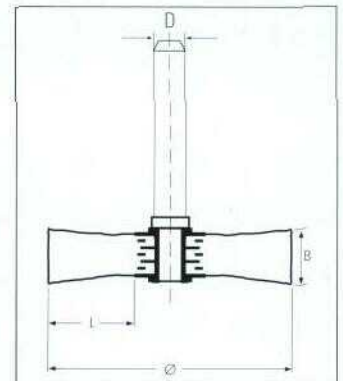

Schaftrundbürsten Alpha Spezial



Shaft-Mounted Circular Brushes Alpha Spezial

Abmessungen/
Dimensions

UPM/
RPM

Type

ANS 320/0.55 **ANS 180/0.90** **ANS 120/1.00**

∅	B	L	D	max.	Type	ANS 320/0.55 Art.-No.	ANS 180/0.90 Art.-No.	ANS 120/1.00 Art.-No.
38 (1 1/2")	10	8	6	20000	AS-SH381 S	9949.5001	9949.5005	9949.5009
51 (2")	10	11	6	15000	AS-SH511 S	9949.5002	9949.5006	9949.5010
63 (2 1/2")	10	18	6	15000	AS-SH631 S	9949.5003	9949.5007	9949.5011
75 (2 7/8")	10	24	6	15000	AS-SH751 S	9949.5004	9949.5008	9949.5012

 **Kullen**
Die Welt der Bürstentechnik

Schafttopfbürsten Record und Alpha

Record: Record Schafttopfbürsten werden mit gewellten Drähten in verschiedenen Qualitäten gefertigt. Ideal zur Flächenbearbeitung in Elektro- und Druckluftwerkzeugen.

Besatzarten: RECORD
STD – Stahldraht naturhart, gewellt.

INOX – Stahldraht, nichtrostend und säurebeständig, gewellt.
MES – Messing-Draht (Cu-Zn), gewellt.

Anwendungen:
 Zum Entfernen von Korrosion, Lack und Grundierungen. Zum Herstellen von reinen Oberflächen an großen Flächen der verschiedensten Metalle.

Alpha:
 Eine hitzestabilisierte Polyamid-Borste mit 20–40 % Schleifkörnern angereichert. Somit sind eine kontinuierliche Schleifwirkung und sehr hohe Standzeiten gewährleistet.

Besatzart: ALPHA
ANS – ANDERLON-Schleifborsten mit Silicium-Carbid-Korn, gewellt.

Anwendungen:
 Zum Flächen-Entgraten, Mattieren und Satinieren.

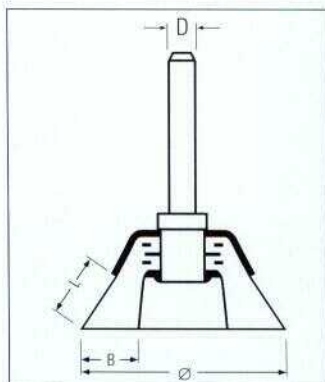

Schafttopfbürsten Record



Shaft-Mounted Cup Brushes Record

Abmessungen/ Dimensions	Dimensions			UPM/ RPM	Type						
	∅	B	L			D	0.15 STD	0.20 STD	0.30 STD	0.15 INOX	0.20 INOX
mm	mm	mm	mm	max.		Art.-No.	Art.-No.	Art.-No.	Art.-No.	Art.-No.	Art.-No.
40 (1 1/2")	10	15	6	10500	T 08402 S	9472.0205	9472.0305	9472.0505	9472.4205	9472.4305	9472.4505
50 (2")	10	20	6	10500	T 08502 S	9472.0207	9472.0307	9472.0507	9472.4207	9472.4307	9472.4507
	50	20	6	10500	TV 08502 S	9901.0058	9901.0052	9901.0053	9901.0036	9901.0056	9901.0085
60 (2 3/8")	15	20	6	4500	T 1602 S	9482.0209	9482.0309	9482.0509	9482.4209	9482.4309	9482.4509
	60	20	6	4500	TV 1602 S	9901.0385	9901.0251	9901.0062	9901.0061	9901.0225	9901.0106
70 (2 3/4")	15	25	6	4500	T 1702 S	9482.0211	9482.0311	9482.0511	9482.4211	9482.4311	9482.4511
	70	25	6	4500	TV 1702 S	9901.0566	9901.0090	9901.0054	9901.0567	9901.0214	9901.0070

Schafttopfbürsten Record



Shaft-Mounted Cup Brushes Record

Abmessungen/ Dimensions	Dimensions			UPM/ RPM	Type			
	∅	B	L			D	0.15 MES	0.20 MES
mm	mm	mm	mm	max.		Art.-No.	Art.-No.	Art.-No.
40 (1 1/2")	10	15	6	10500	T 08402 S	9472.6205	9472.6305	9472.6505
50 (2")	10	20	6	10500	T 08502 S	9472.6207	9472.6307	9472.6507
	50	20	6	10500	TV 08502 S	9901.0568	9901.0383	9901.0215
60 (2 3/8")	15	20	6	4500	T 1602 S	9482.6209	9482.6309	9482.6509
	60	20	6	4500	TV 1602 S	9901.0569	9901.0571	9901.0572
70 (2 3/4")	15	25	6	4500	T 1702 S	9482.6211	9482.6311	9482.6511
	70	25	6	4500	TV 1702 S	9901.0570	9901.0384	9901.0573

Shaft-Mounted Cup Brushes Record and Alpha

Record: Record shaft-mounted cup brushes are available with crimped wire in various qualities. Ideal for work on large surfaces with electrical and pneumatic tools.

Fill types: RECORD

STD – Steel wire, natural hard, crimped.

INOX – Stainless steel wire, acid resistant, crimped.

MES – Brass wire (Cu-Zn), crimped.

Applications:

Removal of rust, paint and other surface contaminants to produce a clean surface finish on all types of metal.

Alpha:

Heat-resistant polyamide filaments, impregnated, with 20–40% abrasive grit will provide a consistent grinding action and extremely long service life.

Fill type: ALPHA

ANS – ANDERLON abrasive filaments, silicon-carbide grit, crimped.

Applications: Surface deburring and the production of matt and satin finishes.

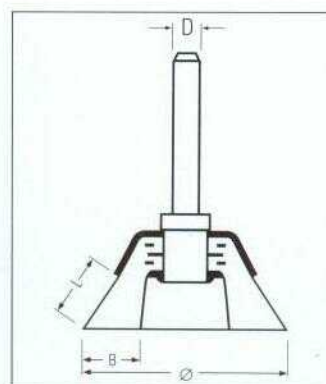

Schafttopfbürsten Alpha



Shaft-Mounted Cup Brushes Alpha

Abmessungen/
Dimensions

Ø	B	L	D	UPM/ RPM	Type	ANS	
						320/0.55	180/0.90
mm	mm	mm	mm	max.		Art.-No.	Art.-No.
40 (1 1/2")	10	15	6	10500	AS-T08402 S	9901.0227	9901.0424
50 (2")	10	20	6	10500	AS-T08502 S	9901.0228	9901.0574
60 (2 3/8")	15	20	6	4500	AS-T1602 S	9901.0575	9901.0462
70 (2 3/4")	15	25	6	4500	AS-T1702 S	9901.0236	9482.9811

Pinselfürsten Record und Alpha

Record: Record Pinselfürsten werden mit gewellten Drähten in verschiedenen Qualitäten gefertigt. Sie sind die Richtigen für schwer zugängliche Bereiche wie Ecken, Bohrungen und Vertiefungen jeder Art.

Besatzarten: RECORD
STD – Stahldraht naturhart, gewellt.
INOX – Stahldraht, nichtrostend und säurebeständig, gewellt.
MES – Messing-Draht (Cu-Zn), gewellt.
Anwendungen: Zum Entrosten, Entfernen von Lacken, Korrosion und Grundierungen, zum Reinigen von Formen und Gußteilen.

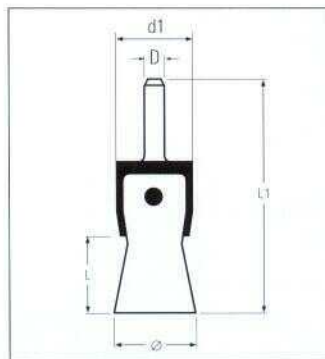

Alpha: Eine hitzestabilisierte Polyamid-Borste mit 20–40% Schleifkörnern angereichert.

Besatzart: ALPHA
ANS – ANDERLON-Schleifborsten mit Silicium-Carbid-Korn, gewellt.
Anwendungen: Zum Entgraten, Mattieren, Glätten und Schleifen.



Pinselfürsten Record



End Brushes Record

Abmessungen/ Dimensions φ	d1	L	D	L1	UPM/ RPM max.	Type	0.20 INOX	0.30 INOX	0.20 MES	0.30 MES
							Art.-No.	Art.-No.	Art.-No.	Art.-No.
Record										
12 (1/2")	10	20	6	60	20000	P 10	9310.4300	9310.4500	9310.6300	9310.6500
17 (11/16")	15	22	6	65	18000	P 15	9315.4300	9315.4500	9315.6300	9315.6500
24 (15/16")	22	25	6	68	18000	P 22	9322.4300	9322.4500	9322.6300	9322.6500
30 (1 1/4")	28	25	6	68	15000	P 28	9328.4300	9328.4500	9328.6300	9328.6500
10 (3/8")	8	20	6	120	20000	P 8 L-95	9308.4310	9308.4510	9308.6310	9308.6510
12 (1/2")	10	20	6	120	20000	P 10 L-100	9310.4310	9310.4510	9310.6310	9310.6510
18 (11/16")	16	22	6	147	18000	P 16 L-125	9316.4310	9316.4510	9316.6310	9316.6510
50 (2")	22	25	6	68	15000	G 2250	9322.4301	9322.4501	9322.6301	9322.6501
	28	20	6	63	15000	G 2850	9328.4303	9328.4503	9328.6303	9328.6503
70 (2 3/4")	28	25	6	68	15000	G 2870	9328.4301	9328.4501	9328.6301	9328.6501

Pinselfürsten Record



End Brushes Record

Abmessungen/ Dimensions φ	d1	L	D	L1	UPM/ RPM max.	Type	0.20 STD	0.30 STD	0.50 STD
							Art.-No.	Art.-No.	Art.-No.
Record									
12 (1/2")	10	20	6	60	20000	P 10	9310.0300	9310.0500	9310.0800
17 (11/16")	15	22	6	65	18000	P 15	9315.0300	9315.0500	9315.0800
24 (15/16")	22	25	6	68	18000	P 22	9322.0300	9322.0500	9322.0800
30 (1 1/4")	28	25	6	68	15000	P 28	9328.0300	9328.0500	9328.0800
10 (3/8")	8	20	6	120	20000	P 8 L-95	9308.0310	9308.0510	9308.0810
12 (1/2")	10	20	6	120	20000	P 10 L-100	9310.0310	9310.0510	9310.0810
18 (11/16")	16	22	6	147	18000	P 16 L-125	9316.0310	9316.0510	9316.0810
50 (2")	22	25	6	68	15000	G 2250	9322.0301	9322.0501	9322.0801
	28	20	6	63	15000	G 2850	9328.0303	9328.0503	9328.0803
70 (2 3/4")	28	25	6	68	15000	G 2870	9328.0301	9328.0501	9328.0801

End Brushes Record and Alpha

Record: Record end brushes are produced from crimped wire in various qualities.

They are the perfect brush for hard-to-reach areas such as corners, drilled holes and recesses of all kinds.

Fill types: RECORD

STD – Steel wire, natural hard, crimped.

INOX – Stainless steel wire, acid resistant, crimped.

MES – Brass wire (Cu-Zn), crimped.

Applications: Removal of paint, rust and primer, and the cleaning of moulds and castings.

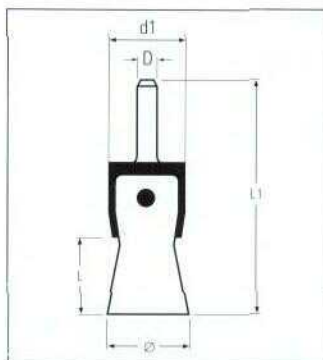

Alpha: Heat-resistant polyamide filaments, impregnated, with 20–40% abrasive grit.

Fill type: ALPHA

ANS – ANDERLON abrasive filaments, silicon-carbide grit, crimped.

Applications: The removal of fine burrs and the production of matt and satin finishes.



Pinselbürsten Alpha



Wear eye protection!

End Brushes Alpha

Abmessungen/ Dimensions	d1	L	D	L1	UPM/ RPM	Type	ANS	ANS	ANS
							320/0.55	180/0.90	120/1.00
∅	mm	mm	mm	mm	max.		Art.-No.	Art.-No.	Art.-No.
12 (1/2")	10	20	6	60	20000	AS-P 10	9310.9700	9310.9800	9310.9900
17 (11/16")	15	22	6	65	18000	AS-P 15	9315.9700	9315.9800	9315.9900
24 (15/16")	22	25	6	68	18000	AS-P 22	9322.9700	9322.9800	9322.9900
30 (1 1/4")	28	25	6	68	15000	AS-P 28	9328.9700	9328.9800	9328.9900

Pinselbürsten Multicord/Delta/Plus-Ultra

Multicord: Sie wird durch die Seilkonstruktion der Drähte noch aggressiver.

Besatzart: MULTICORD

LIT – Stahldraht vermessingt, federhart und zäh, in Seilkonstruktion, gewellt.

Anwendungen: Für besonders schwere Beanspruchung in schwer zugänglichen Bereichen.

Delta: Eingebettet in eine elastische Kunststoffmasse – dadurch besonders aggressiv.

Besatzart: DELTA

LTE – Stahldraht vermessingt, Einzeldraht, federhart, gewellt.

Anwendungen: Zum Bearbeiten von Schweißnähten und -punkten sowie zum Entfernen von Zunder-schichten.

Plus-Ultra: Einzelstehender Zopf, ölschlußgehärteter Draht – beste Voraussetzungen für extreme Aggressivität.

Der Besatz spreizt sich unter hohen Drehzahlen zur Form einer Schaftrundbürste.

Besatzarten: PLUS-ULTRA

AZD – Stahldraht gehärtet, hart und zäh, glatt.

INOX – Stahldraht, nichtrostend und säurebeständig, glatt.

Anwendungen: Zum Bearbeiten von Schweißnähten und -punkten. Zum Entfernen von zähen, dicken und klebrigen Massen sowie hartnäckiger Korrosion.



Pinselbürsten Multicord

Abmessungen/
Dimensions

∅	d1	L	D	L1	UPM/ RPM	Type
mm	mm	mm	mm	mm	max.	
12 (1/2")	10	20	6	60	20000	MC-P 10
17 (11/16")	15	22	6	65	18000	MC-P 15
24 (15/16")	22	25	6	68	18000	MC-P 22
30 (1 1/4")	28	25	6	68	15000	MC-P 28
10 (3/8")	8	20	6	120	20000	MC-P 8 L-95
13 (1/2")	11	20	6	120	20000	MC-P 11 L-100
18 (11/16")	16	22	6	147	18000	MC-P 16 L-125



Wear eye protection!

End Brushes Multicord

0.15 LIT	0.20 LIT	0.27 LIT
Art.-No.	Art.-No.	Art.-No.
9310.7100	9310.7300	9310.7500
9315.7100	9315.7300	9315.7500
9322.7100	9322.7300	9322.7500
9328.7100	9328.7300	9328.7500
9308.7110	9308.7310	9308.7510
9311.7110	9311.7310	9311.7510
9316.7110	9316.7310	9316.7510



Pinselbürsten Delta

Abmessungen/
Dimensions

∅	d1	L	D	L1	UPM/ RPM	Type
mm	mm	mm	mm	mm	max.	
10 (3/8")	10	25	6	60	20000	DK-P 10
15 (5/8")	15	25	6	65	15000	DK-P 15
22 (7/8")	22	25	6	68	13000	DK-P 22
28 (1 1/8")	28	25	6	68	13000	DK-P 28



Wear eye protection!

End Brushes Delta

0.30 LTE
Art.-No.
9918.3014
9918.3001
9918.3002
9918.3003

End Brushes Multicord/Delta/Plus-Ultra

Multicord: Its cable-type wires give this brush an even more aggressive action.

Fill type: MULTICORD

LIT – Brass plated steel wire, tempered and tough, cord construction, crimped.

Applications: For heavy-duty use in hard-to-reach areas.

Delta: Embedded in flexible plastic, the wires of these brushes offer an extremely aggressive action.

Fill type: DELTA

LTE – Brass plated steel wire, tempered, single-wire, crimped.

Applications: Working on weld seams and spot-welds. The removal of scale.

Plus-Ultra: Twist knot construction and oil-hardened wire – the perfect combination for an powerful aggressive action. The fill material splays at high speed to form a shaft-mounted circular brush.

Fill types: PLUS-ULTRA

AZD – Steel wire, hardened, high tensile strength and tough, straight.

INOX – Stainless steel wire, acid resistant, straight.

Applications: Working on weld seams and spot-welds. Removal of tough, thick and sticky compounds and heavy duty application such as the removal of stubborn corrosion.

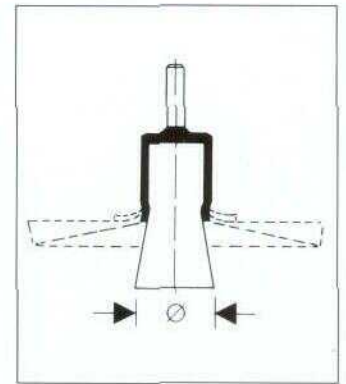
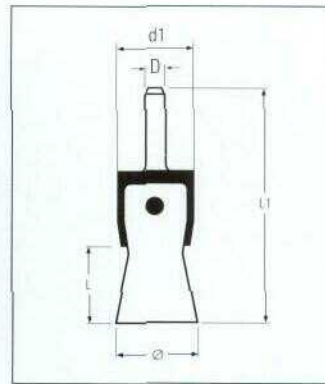

Pinselfürsten Plus-Ultra



End Brushes Plus-Ultra

Abmessungen/ Dimensions		d1	L	D	L1	UPM/ RPM	Type	0.25 AZD	0.35 AZD	0.50 AZD
φ	Z*							Art.-No.	Art.-No.	Art.-No.
mm		mm	mm	mm	mm	max.				
19 (3/4")	6	19	28	6	68	20000	ZP 19	9030.1003	9030.1005	-
22 (7/8")	8	22	28	6	68	20000	ZP 22	9030.1039	9030.1041	9030.1042
28 (1 1/8")	12	28	28	6	68	20000	ZP 28	9030.1023	9030.1025	9030.1026

Pinselfürsten Plus-Ultra



End Brushes Plus-Ultra

Abmessungen/ Dimensions		d1	L	D	L1	UPM/ RPM	Type	0.25 INOX	0.35 INOX	0.50 INOX
φ	Z*							Art.-No.	Art.-No.	Art.-No.
mm		mm	mm	mm	mm	max.				
19 (3/4")	6	19	28	6	68	20000	ZP 19	9030.1013	9030.1015	-
22 (7/8")	8	22	28	6	68	20000	ZP 22	9030.1037	9030.1040	9030.1046
28 (1 1/8")	12	28	28	6	68	20000	ZP 28	9030.1033	9030.1035	9030.1036

Z* = Anzahl der Zöpfe pro Reihe/Number of knots per row

Innenbürsten Interior Brushes

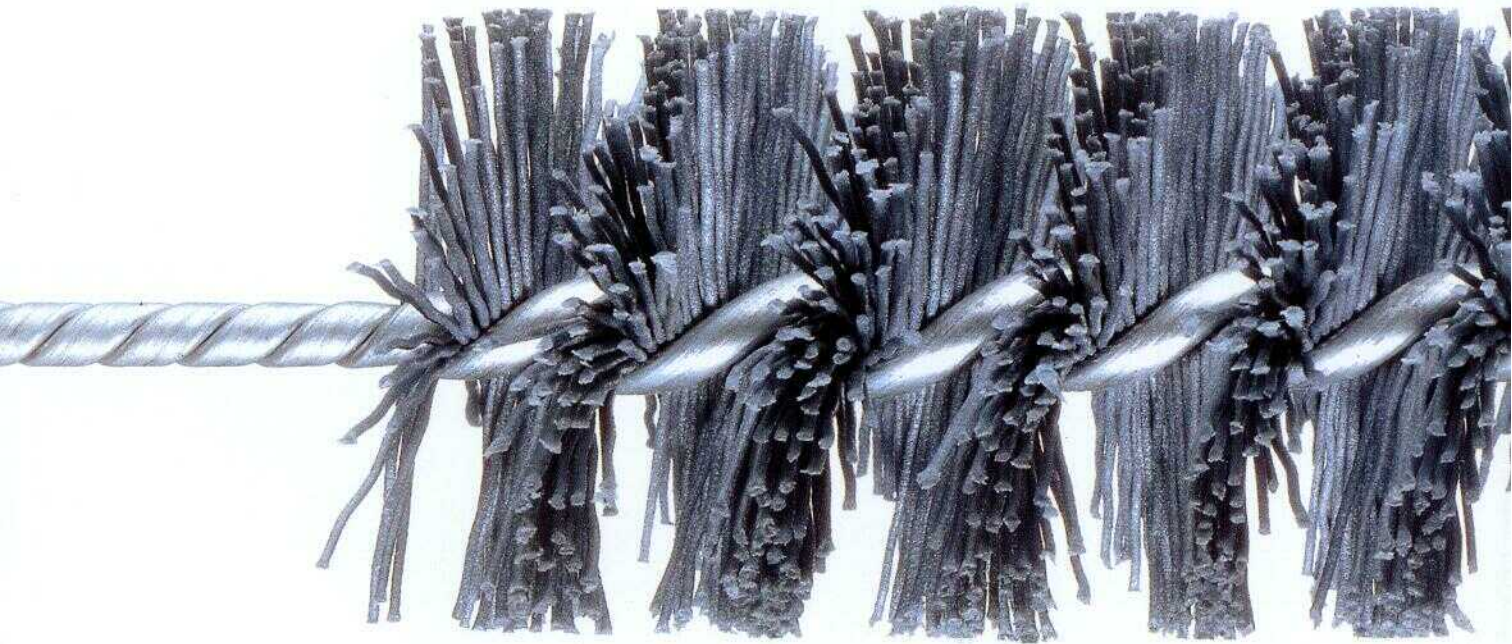

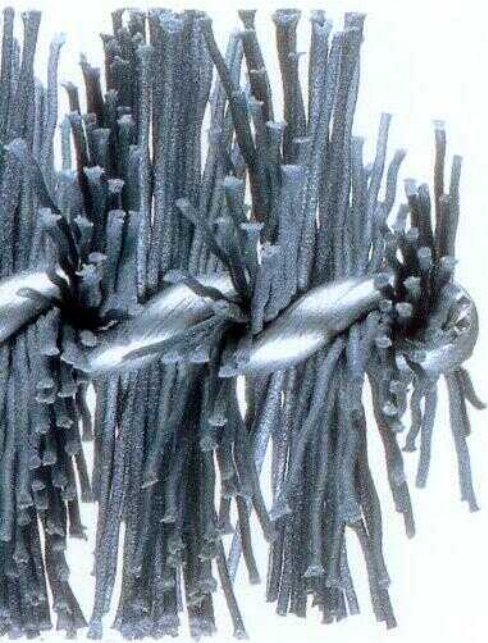

Innenbürsten	
Interior Brushes	38
Siederohrbürsten	
Tube-Cleaning Brushes	38

Die Fachkräfte im Innendienst

Innenbürsten: Sie sind Insider beim Entgraten. Innenbürsten mit verzinktem Drehdraht und einfacher Besatzspirale, dicht besetzt. Besatzlänge und Gesamtlänge unterscheiden sich je Besatzart (s. Tabelle). Sie eignen sich für Bohrmaschinen, biegsame Wellen und Bearbeitungszentren.

Besatzarten:

ANA – ANDERLON-Schleifborsten mit Aluminium-Oxyd-Korn, glatt.

ANS – ANDERLON-Schleifborsten mit Silicium-Carbid-Korn, gewellt.

SSD – Stahldraht, hart und zäh, gewellt.

Anwendungen: Entgraten von O-Ring-Einstichen, Bohrungen,

zum Reinigen, Glätten und Entrosten.

Siederohrbürsten: Zur Pflege der inneren Werte. Siederohrbürsten mit vierfachem Drehdraht und aufgepreßtem 1/2-Zoll-Anschlußgewinde. Sie eignen sich zur Handbearbeitung sowie zum Einsatz in biegsamen Wellen und in stationären Maschinen.

Besatzart:

OSG – Stahldraht, gehärtet, glatt.

Anwendungen:

Speziell zur Rohr-Innenreinigung. Zum Entrosten, Reinigen und Entzundern.

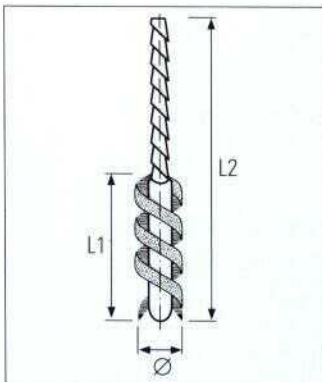

Innenbürsten



Interior Brushes

Abmessungen/ Dimensions		ANA	ANA	ANS	ANS	0.12 SSD
ø	Type	600/0.25	600/0.30	320/0.55	180/0.90	
mm		L1=25/L2=125	L1=25/L2=125	L1=65/L2=125	L1=65/L2=125	L1=25/L2=85
2,2	GBS 2,2	7021.5493	-	-	-	-
2,7	GBS 2,7	7021.5494	-	-	-	-
3,2	GBS 3,2	7021.5495	-	-	-	-
3,8	GBS 3,8	7021.5496	-	-	-	-
4,3	GBS 4,3	7021.5497	7021.5498	-	-	-
5,0	GBS 5,0	-	7021.5500	-	-	7009.0128
5,5	GBS 5,5	-	7021.5501	-	-	7009.0155
6,0	GBS 6,0	-	7021.5502	7021.5244	-	7009.0037
7,0	GBS 7,0	-	-	7021.5481	-	7009.0138
8,0	GBS 8,0	-	-	7021.5309	-	7009.0031
9,0	GBS 9,0	-	-	7021.5031	-	7009.0065
10	GBS 10	-	-	7002.7313	7002.7314	7009.0029
11	GBS 11	-	-	7021.5041	7002.7564	7009.0156
12	GBS 12	-	-	7002.7315	7002.7316	7009.0038
13	GBS 13	-	-	7002.7503	7002.7507	7009.0028
14	GBS 14	-	-	7002.7317	7002.7318	7009.0027
15	GBS 15	-	-	7021.5373	7002.7565	7009.0157
16	GBS 16	-	-	7002.7005	7002.7504	7009.0030
17	GBS 17	-	-	7002.7556	7002.7505	7009.0158
18	GBS 18	-	-	7002.7440	7002.7020	7009.0039
19	GBS 19	-	-	7002.7319	7002.7320	7009.0040
20	GBS 20	-	-	7002.7557	7002.7566	7009.0041
21	GBS 21	-	-	7021.5292	7002.7567	7009.0159
22	GBS 22	-	-	7002.7321	7002.7322	7009.0042
23	GBS 23	-	-	7002.7502	7002.7506	7009.0160
24	GBS 24	-	-	7002.7558	7002.7011	7009.0043
25	GBS 25	-	-	7002.7323	7002.7324	7009.0044
26	GBS 26	-	-	7002.7559	7002.7568	7009.0161
27	GBS 27	-	-	7009.0136	7002.7569	7009.0045
28	GBS 28	-	-	7002.7560	7002.7391	7009.0162
29	GBS 29	-	-	7002.7396	7002.7570	7009.0046
30	GBS 30	-	-	7002.7561	7002.7501	7009.0163
31	GBS 31	-	-	7002.7562	7002.7571	7009.0164
32	GBS 32	-	-	7002.7325	7002.7326	7009.0047

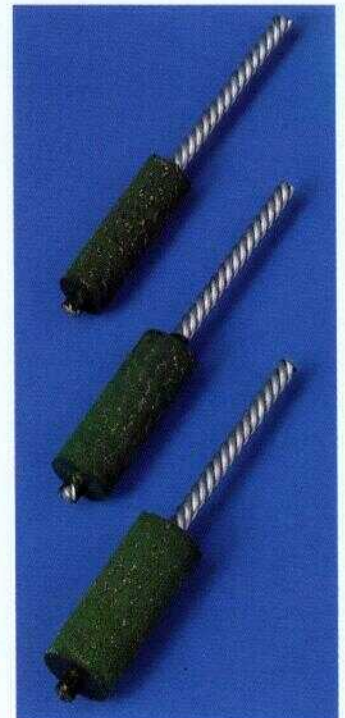

Delta-Innenbürsten auf Anfrage. Die Drähte sind in eine elastische Kunststoffmasse eingebettet und dadurch besonders aggressiv und langlebig.

Delta interior brushes available on request. The wires are encapsulated in a plastic compound to provide an aggressive action and long service life.

The specialists on the inside track

Interior brushes: These are the insiders for deburring. The twisted, galvanised core wires of the interior brush form a high density single spiral fill pattern. The brush face length and overall length vary according to the type of fill material (see table for details), suitable for use

with hand power tools and automatic machines.

Fill types:

ANA – ANDERLON abrasive filaments, aluminiumoxide grit, straight.
ANS – ANDERLON abrasive filaments, silicon-carbide grit, crimped.
SSD – Steel wire, high tensile strength and tough, crimped.

Applications: Deburring of O-ring recesses and drilled cross holes and for cleaning, smoothing and the removal of rust etc.

Tube-cleaning brushes:

For aggressive internal cleaning. Tube-cleaning brushes feature a strong four core twisted wire stem and 1/2" whitworth

male threaded connector. For hand use with extension rods or power driven flexible shaft and bench machines.

Fill types:

OSG – Steel wire, hardened, straight.
Applications: Specially designed for boiler tube-cleaning, for the removal of rust and scale.

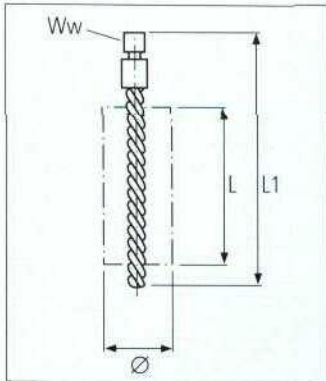

Siederohrbürsten



Wear eye protection!

Tube-Cleaning Brushes

Abmessungen/
Dimensions

ø	L	L1	0.20 OSG	0.30 OSG	0.40 OSG	0.50 OSG
mm	mm	mm	Art.-No.	Art.-No.	Art.-No.	Art.-No.
20	100	160	7023.2159	-	-	-
25	100	160	7023.2108	-	-	-
28	100	160	7023.2005	-	-	-
30	100	160	-	7023.2095	-	-
32	100	160	-	7023.2006	-	-
33	100	160	-	7023.2003	-	-
38	100	160	-	7023.2009	-	-
40	100	160	-	7023.2045	-	-
44	100	160	-	7023.2010	-	-
45	100	160	-	7023.2175	-	-
50	100	160	-	-	7023.2125	-
53	100	160	-	-	7023.2260	-
57	100	160	-	-	7023.2261	-
60	100	160	-	-	7023.2057	-
63	100	160	-	-	7023.2296	-
65	100	160	-	-	7023.2107	-
69	100	160	-	-	7023.2141	-
70	100	160	-	-	7023.2052	-
75	100	160	-	-	7023.2022	-
82	100	160	-	-	7023.2147	-
88	100	160	-	-	7023.2168	-
94	100	160	-	-	-	7023.2099
101	100	160	-	-	-	7023.2157



Alphahon- und Lochreinigungsbürsten sowie Sondertypen mit flachgepreßtem Draht auf Anfrage.

Alphahon and other special brush types with a flat wire fill are available on request.

 **Kullen**
Die Welt der Bürstentechnik

Rundbürsten

Circular Brushes





Rundbürsten
Circular Brushes
RECORD/ULTRA

42

Rundbürsten Record und Ultra: Die kompakten Kraftpakete

Eine runde Sache – die gewellte Record und die gezopfte Ultra. Beide haben genau die richtige Energie, um mit allem fertig zu werden, was sich ihnen in den Weg stellt – aber die Ultra verfügt dank ihrer Zöpfe über den Extra-Biß.

Wenn sie ins Rotieren kommen, werden Fertigungsprobleme glattweg gelöst. Unterschiedliche Besatzdichten und zwei bzw. drei Standardbreiten stehen zur Wahl. Eingesetzt werden sie in stationären Maschinen und biegsamen Wellen mit verschiedenen Aufnahme-durchmessern.

Besatzarten: RECORD

STD – Stahldraht naturhart, gewellt.

INOX – Stahldraht, nichtrostend und säurebeständig, gewellt.

MES – Messing-Draht (Cu-Zn), gewellt.

Anwendungen: Entrosten, Reinigen, Glätten, Polieren, Mattieren, Entlacken und Aufräumen.

Besatzarten: ULTRA

SUP – Stahldraht gehärtet, glatt.

INOX – Stahldraht, nichtrostend und säurebeständig, glatt.

Anwendungen: Schweißnahtbearbeitung, Entfernen von Härtezunder und Lack, Entgraten sowie Verputzen von Gußteilen und Gummi-Metall-Verbindungen.

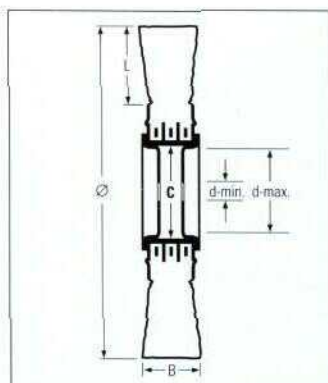

Rundbürsten Record



Circular Brushes Record

Abmessungen/ Dimensions	UPM/ RPM						Type						
	B	C	L	d	d	d		0.20 STD	0.30 STD	0.50 STD	0.20 INOX	0.30 INOX	0.30 MES
ø	mm	mm	mm	min.	max.	max.	Art.-No.	Art.-No.	Art.-No.	Art.-No.	Art.-No.	Art.-No.	
60 (2 3/8")	15	20	10	8	16	15000	262	9122.0309	9122.0509	9122.0809	9122.4309	9122.4509	9122.6509
	22	20	10	8	16	15000	263	9123.0309	9123.0509	9123.0809	9123.4309	9123.4509	9123.6509
	29	20	10	8	16	15000	264	9124.0309	9124.0509	9124.0809	9124.4309	9124.4509	9124.6509
80 (3")	15	20	20	8	16	10000	282	9122.0313	9122.0513	9122.0813	9122.4313	9122.4513	9122.6513
	22	20	20	8	16	10000	283	9123.0313	9123.0513	9123.0813	9123.4313	9123.4513	9123.6513
	29	20	20	8	16	10000	284	9124.0313	9124.0513	9124.0813	9124.4313	9124.4513	9124.6513
100 (4")	20	30	24	8	25	6000	3102	9132.0317	9132.0517	9132.0817	9132.4317	9132.4517	9132.6517
	28	30	24	8	25	6000	3103	9133.0317	9133.0517	9133.0817	9133.4317	9133.4517	9133.6517
	36	30	24	8	25	6000	3104	9134.0317	9134.0517	9134.0817	9134.4317	9134.4517	9134.6517
125 (5")	24	30	36	8	25	6000	3122	9132.0322	9132.0522	9132.0822	9132.4322	9132.4522	9132.6522
	32	30	36	8	25	6000	3123	9133.0322	9133.0522	9133.0822	9133.4322	9133.4522	9133.6522
	40	30	36	8	25	6000	3124	9134.0322	9134.0522	9134.0822	9134.4322	9134.4522	9134.6522
150 (6")	18	51	27	8	40	6000	5152	9152.0327	9152.0527	9152.0827	9152.4327	9152.4527	9152.6527
	29	51	27	8	40	6000	5153	9153.0327	9153.0527	9153.0827	9153.4327	9153.4527	9153.6527
	36	51	27	8	40	6000	5154	9154.0327	9154.0527	9154.0827	9154.4327	9154.4527	9154.6527
180 (7")	22	51	42	8	40	6000	5182	9152.0333	9152.0533	9152.0833	9152.4333	9152.4533	9152.6533
	28	51	42	8	40	6000	5183	9153.0333	9153.0533	9153.0833	9153.4333	9153.4533	9153.6533
	36	51	42	8	40	6000	5184	9154.0333	9154.0533	9154.0833	9154.4333	9154.4533	9154.6533
200 (8")	26	80	40	10	75	4500	8202	9172.0337	9172.0537	9172.0837	9172.4337	9172.4537	9172.6537
	36	80	40	10	75	4500	8203	9173.0337	9173.0537	9173.0837	9173.4337	9173.4537	9173.6537
	45	80	40	10	75	4500	8204	9174.0337	9174.0537	9174.0837	9174.4337	9174.4537	9174.6537
250 (10")	32	100	50	10	94	3600	10252	9182.0343	9182.0543	9182.0843	9182.4343	9182.4543	9182.6543
	38	100	50	10	94	3600	10253	9183.0343	9183.0543	9183.0843	9183.4343	9183.4543	9183.6543
	42	100	50	10	94	3600	10254	9184.0343	9184.0543	9184.0843	9184.4343	9184.4543	9184.6543
300 (12")	32	100	60	10	94	3000	10302	9182.0348	9182.0548	9182.0848	9182.4348	9182.4548	9182.6548
	38	100	60	10	94	3000	10303	9183.0348	9183.0548	9183.0848	9183.4348	9183.4548	9183.6548
	48	100	60	10	94	3000	10304	9184.0348	9184.0548	9184.0848	9184.4348	9184.4548	9184.6548
350 (14")	34	100	85	10	94	2400	10352	9182.0353	9182.0553	9182.0853	9182.4353	9182.4553	9182.6553
	39	100	85	10	94	2400	10353	9183.0353	9183.0553	9183.0853	9183.4353	9183.4553	9183.6553
	50	100	85	10	94	2400	10354	9184.0353	9184.0553	9184.0853	9184.4353	9184.4553	9184.6553

Record and Ultra: circular brushes for all-round power

When you need concentrated power choose the "Record" crimped wire or the "Ultra" twist knot range of brushes. In situations where extra aggression is required, the twist knot form of the Ultra will prove ultra-effective.

These specialised brushes work fast – smoothing down surfaces, smoothing-out those production problems. Designed for use on bench machines or portable power tools they are readily-available with a choice of fill materials, face widths and arbor hole diameters.

Fill types: RECORD

STD – Steel wire, natural hard, crimped.

INOX – Stainless steel wire, acid resistant, crimped.

MES – Brass wire (Cu-Zn), crimped.

Applications:

Applications include rust and paint removal, deburring, descaling, matt finishing and polishing.

Fill types: ULTRA

SUP – Steel wire, hardened, straight.

INOX – Stainless steel wire, acid resistant, straight.

Applications:

Weld preparation, deburring and heavy duty cleaning tasks such as the finishing of castings, the removal of hardened paint, scale, stubborn rust and rubber flashing.

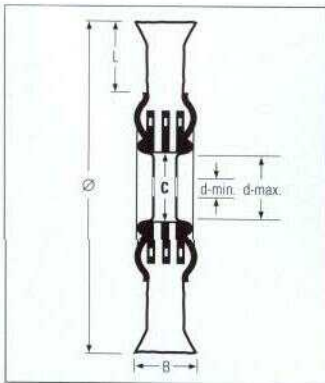

Rundbürsten Ultra



Circular Brushes Ultra

Abmessungen/ Dimensions	Z*	B	C	L	d		UPM/ RPM	Type						
					min.	max.			max.	0.35 SUP	0.50 SUP	0.80 SUP	0.35 INOX	0.50 INOX
ø		mm	mm	mm					Art.-No.	Art.-No.	Art.-No.	Art.-No.	Art.-No.	Art.-No.
100 (4")	18	18	20	22	10	16	11000	Z 2102	9222.1117	9222.1317	9222.1517	9222.4117	9222.4317	9222.4517
	18	26	20	22	10	16	11000	Z 2103	9223.1117	9223.1317	9223.1517	9223.4117	9223.4317	9223.4517
125 (5")	22	18	30	25	10	22,2	11000	Z 3122	9232.1122	9232.1322	9232.1522	9232.4122	9232.4322	9232.4522
	22	26	30	25	10	22,2	11000	Z 3123	9233.1122	9233.1322	9233.1522	9233.4122	9233.4322	9233.4522
150 (6")	24	18	30	29	10	22,2	9000	Z 3152	9232.1127	9232.1327	9232.1527	9232.4127	9232.4327	9232.4527
	24	26	30	29	10	22,2	9000	Z 3153	9233.1127	9233.1327	9233.1527	9233.4127	9233.4327	9233.4527
180 (7")	28	18	40	34	10	22,2	9000	Z 4182	9242.1133	9242.1333	9242.1533	9242.4133	9242.4333	9242.4533
	28	26	40	34	10	22,2	9000	Z 4183	9243.1133	9243.1333	9243.1533	9243.4133	9243.4333	9243.4533
200 (8")	32	22	51	44	10	40	8500	Z 5202	9252.1137	9252.1337	9252.1537	9252.4137	9252.4337	9252.4537
	32	32	51	44	10	40	8500	Z 5203	9253.1137	9253.1337	9253.1537	9253.4137	9253.4337	9253.4537
	32	42	51	44	10	40	8500	Z 5204	9254.1137	9254.1337	9254.1537	9254.4137	9254.4337	9254.4537
250 (10")	42	24	80	54	10	60	4500	Z 8252	9272.1143	9272.1343	9272.1543	9272.4143	9272.4343	9272.4543
	42	34	80	54	10	60	4500	Z 8253	9273.1143	9273.1343	9273.1543	9273.4143	9273.4343	9273.4543
	42	43	80	54	10	60	4500	Z 8254	9274.1143	9274.1343	9274.1543	9274.4143	9274.4343	9274.4543
300 (12")	50	25	100	69	10	80	3600	Z 10302	9282.1148	9282.1348	9282.1548	9282.4148	9282.4348	9282.4548
	50	38	100	69	10	80	3600	Z 10303	9283.1148	9283.1348	9283.1548	9283.4148	9283.4348	9283.4548
	50	51	100	69	10	80	3600	Z 10304	9284.1148	9284.1348	9284.1548	9284.4148	9284.4348	9284.4548

*Z = Anzahl der Zöpfe pro Reihe/Number of knots per row



Aufrauen vor der Runderneuerung mit Ultra Rundbürsten – so ermöglicht Bürstentechnik auch Recycling.

Brush technology can assist in recycling processes: Here "Ultra" brushes being used to roughen the surface of tyre casings prior to remoulding.

 **Kullen**
Die Welt der Bürstentechnik

Einzelscheiben-Bürsten

Single-Section Brushes



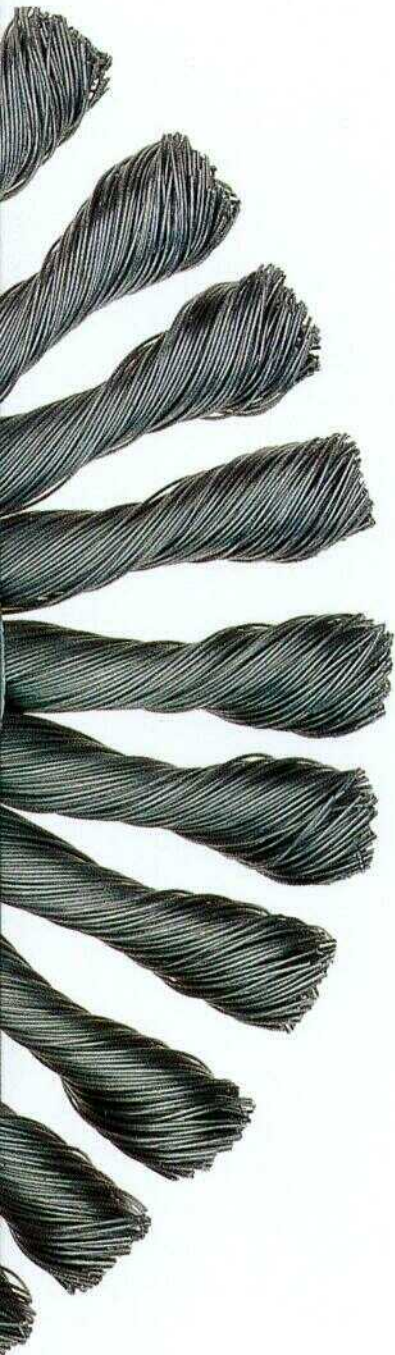

**Anwendungen und
Einsatzgebiete
Applications and
purpose** 46

**Einzelnscheiben-Bürsten
Single-Section Brushes**
RECORD/SUPER-RECORD 48

**Einzelnscheiben-Bürsten
Single-Section Brushes**
MULTICORD/DELTA 50

**Einzelnscheiben-Bürsten
Single-Section Brushes**
ULTRA/PLUS-ULTRA 52

**Einzelnscheiben-Bürsten
Single-Section Brushes**
ALPHA 54

Einzelscheiben-Bürsten: Die schmalen Wilden

Daß Kraft und Ausdauer nicht gleich mit Masse in Verbindung gebracht werden müssen, zeigen Einzelscheiben-Bürsten von KULLEN: Sie sind schmal, aggressiv, robust und äußerst vielseitig.

Die ganze Energie auf wenigen Millimetern – so muß es sein, wenn Sie schmale Werkstücke oder profilierte Oberflächen exakt bearbeiten möchten. Unsere Einzelscheiben-Bürsten sind praktisch ideal dafür. Viele Besatzarten, noch mehr Einsatzbereiche, verschiedene Aufnahme-Bohrungen, absolute Sicherheit bei hohen Drehzahlbereichen und die Möglichkeit, durch Aneinanderreihung von mehreren Einzelscheiben-Bürsten jede Arbeitsbreite zu erreichen, machen sie auch für Ihren Betrieb zu einem wichtigen „Mitarbeiter“.

Wer mit Einzelscheiben-Bürsten von KULLEN bereits arbeitet, weiß, was wir meinen. Wer sie noch nicht kennt, wird auf den folgenden



Schweißnaht-Bearbeitung an einer Pipeline mit der gezopften Ultra Einzelscheiben-Bürste.

Cleaning the welds on pipelines using an Ultra single-section brush with a twist knot fill.

Seiten über viele gute Seiten unserer wilden „Stars“ Record, Super-Record, Multicord, Delta, Ultra, Plus-Ultra und Alpha informiert.

Bei einem Lieferprogramm von über 140.000 Bürsten – dem stärksten in ganz Europa – finden auch Sie Ihre spezielle „schmale Wilde“.



Zwei Alpha Einzelscheiben-Bürsten honen einen Zylinderkopf.

Honing a cylinder head using two Alpha single-section brushes.

Beschreibungen der Besatzarten, Anwendungen, Bearbeitungsfälle, Durchmesser und Details über Reduziereinsätze geben Ihnen einen ausführlichen Einblick in unsere Sortimentsbreite.

Wenn Sie Fragen haben sollten, zum Beispiel zu diesem oder jedem Einsatzbereich, greifen Sie bitte



Präzises Entgraten von Außenkanten an einem Wellenrad aus Stahl.

Here the external edges of a steel pinion gear are being deburred with precision.

einfach zum Hörer und schildern Sie einem unserer Spezialisten den Fall. Oder schreiben Sie uns. Wir werden auch zu Ihrem Problem eine Lösung finden.



Dieser Tourenwagen ist auf Schwingmetallen gelagert, die mit Ultra Einzelscheiben verputzt wurden.



Eine Rundtisch-Entgratmaschine mit zwei Vorschleif- und zwei Bürstenstationen.

A rotary-indexing deburring machine with two rough-grinding and two deburring stations.

Single-Section Brushes – miniature size, mighty performance

Power and endurance are characteristics normally associated with big tools or heavy machinery. However, despite their slender appearance, KULLEN single-section brushes display these qualities in abundance. They are aggressive, robust and remarkably versatile.

To process narrow work-pieces or profile sections with absolute precision involves applying maximum power to an area of just a few millimetres. Our single-section brushes are perfectly suited to the task.

They offer a number of benefits which could prove invaluable to your Company: absolute reliability

at high speeds; an extensive range of fill materials; a wide variety of arbor diameters; countless areas of application; and the potential to achieve any working width simply by installing several single-section brushes side by side.

Anyone who has worked with KULLEN single-section brushes

before will hardly need further convincing! But for those who are unfamiliar with our brushes, the following pages outline the main attributes of Record, Super-Record, Multicord, Delta, Ultra, Plus-Ultra and Alpha.

KULLEN have a product range of over 140.000 brushes – the most powerful line of technical brushes in Europe. Even if your needs are specialised, we are certain to have the brush you are looking for. This brochure presents you with a broad overview of our comprehensive product range. It contains descriptions of the types of fill available, possible applications, notes on use, details of diameters and reducing adapters.

Please do not hesitate to contact us with any questions you may have. Our specialists will be pleased to advise you on the optimum solution to your specific application.



This saloon car body is mounted on rubber-bonded metal bearings which have been trimmed with Ultra single-section brushes.

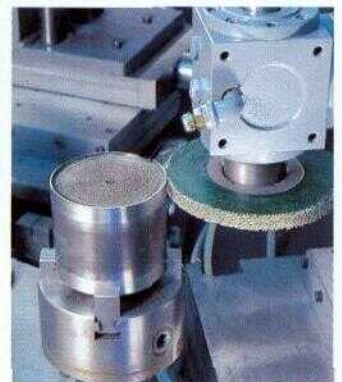

Entzundern eines Filtergehäuses mit der kunststoffgebundenen Delta Einzelscheibenbürste.

Removing scale from a filter bowl with a plastic-bonded Delta single-section brush.



Die Welt der Bürstentechnik

Einzelscheiben-Bürsten Record und Super-Record

Record und Super-Record Einzelscheibenbürsten werden mit gewellten Drähten in verschiedenen Qualitäten gefertigt.

Wir empfehlen Ihnen für diese Bürsten folgende Umfangsgeschwindigkeiten: Zum Bearbeiten von Stahl ca. 30 m/sec, NE-Metall 18–20 m/sec und Kunststoff 15 m/sec.

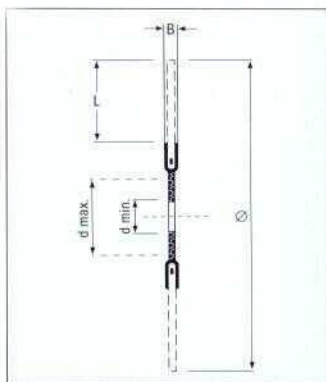
Besatzarten: RECORD
LTE – Stahldraht vermessingt, Einzeldraht, federhart, gewellt.
INOX – Stahldraht, nichtrostend und säurebeständig, gewellt.
STD – Stahldraht naturhart, gewellt.
SUPER-RECORD
ASD – Stahldraht, gehärtet, extrahart und zäh, gewellt.



Anwendungen:
 Entfernen von Rost an Stahlteilen aller Art, Oxydschichten auf Edelstahl oder NE-Metall und Beschichtungen.
 Erzielen von reinen Oberflächen.
 Reinigen von Werkzeugformen.
 Verputzen von Gußteilen.
 Mattieren von Metalloberflächen.

Bearbeitung:
 Für schmale Werkstücke und profilierte Oberflächen auf stationären oder in handgeführten Maschinen.

Reduziereinsätze:
 Siehe Seite 49 unten.



Einzelscheiben-Bürsten Record



Single-Section Brushes Record

Abmessungen/ Dimensions		UPM/ RPM			Type	0.15 LTE	0.30 LTE	0.10 INOX	0.15 INOX	0.20 INOX	0.30 INOX
∅	B	L	d min.	d max.	max.	Art.-No.	Art.-No.	Art.-No.	Art.-No.	Art.-No.	Art.-No.
80 (3")	11	12	12	20	10000	B 381 9831.2113	9831.1013	9831.4113	9831.4213	9831.4313	9831.4513
100 (4")	11	22	12	20	8000	B 3101 9831.2117	9831.1017	9831.4117	9831.4217	9831.4317	9831.4517
125 (5")	11	34	12	20	6000	B 3121 9831.2122	9831.1022	9831.4122	9831.4222	9831.4322	9831.4522
	13	21	12	32	6000	B 5121 9851.2122	9851.1022	9851.4122	9851.4222	9851.4322	9851.4522
150 (6")	13	34	12	32	6000	B 5151 9851.2127	9851.1027	9851.4127	9851.4227	9851.4327	9851.4527
180 (7")	15	44	12	40	6000	B 6181 9861.2133	9861.1033	9861.4133	9861.4233	9861.4333	9861.4533
	13	33	12	50,8	6000	B 8181 9871.2133	9871.1033	9871.4133	9871.4233	9871.4333	9871.4533
200 (8")	13	43	12	50,8	4500	B 8201 9871.2137	9871.1037	9871.4137	9871.4237	9871.4337	9871.4537
250 (10")	15	55	12	50,8	3500	B 10251 9881.2143	9881.1043	9881.4143	9881.4243	9881.4343	9881.4543
300 (12")	15	55	12	50,8	3000	B 15301 9811.2148	9811.1048	9811.4148	9811.4248	9811.4348	9811.4548
350 (14")	15	55	12	50,8	2400	B 19351 9821.2153	9821.1053	9821.4153	9821.4253	9821.4353	9821.4553
380 (15")	15	70	12	50,8	2400	B 19381 9821.2160	9821.1060	9821.4160	9821.4260	9821.4360	9821.4560
400 (15 3/4")	15	80	12	50,8	1800	B 19401 9821.2154	9821.1054	9821.4154	9821.4254	9821.4354	9821.4554

Abmessungen/ Dimensions		UPM/ RPM			Type	0.10 STD	0.15 STD	0.20 STD	0.30 STD	0.50 STD
∅	B	L	d min.	d max.	max.	Art.-No.	Art.-No.	Art.-No.	Art.-No.	Art.-No.
80 (3")	11	12	12	20	10000	B 381 9831.5113	9831.5213	9831.5313	9831.5513	9831.5813
100 (4")	11	22	12	20	8000	B 3101 9831.5117	9831.5217	9831.5317	9831.5517	9831.5817
125 (5")	11	34	12	20	6000	B 3121 9831.5122	9831.5222	9831.5322	9831.5522	9831.5822
	13	21	12	32	6000	B 5121 9851.5122	9851.5222	9851.5322	9851.5522	9851.5822
150 (6")	13	34	12	32	6000	B 5151 9851.5127	9851.5227	9851.5327	9851.5527	9851.5827
180 (7")	15	44	12	40	6000	B 6181 9861.5133	9861.5233	9861.5333	9861.5533	9861.5833
	13	33	12	50,8	6000	B 8181 9871.5133	9871.5233	9871.5333	9871.5533	9871.5833
200 (8")	13	43	12	50,8	4500	B 8201 9871.5137	9871.5237	9871.5337	9871.5537	9871.5837
250 (10")	15	55	12	50,8	3500	B 10251 9881.5143	9881.5243	9881.5343	9881.5543	9881.5843
300 (12")	15	55	12	50,8	3000	B 15301 9811.5148	9811.5248	9811.5348	9811.5548	9811.5848
350 (14")	15	55	12	50,8	2400	B 19351 9821.5153	9821.5253	9821.5353	9821.5553	9821.5853
380 (15")	15	70	12	50,8	2400	B 19381 9821.5160	9821.5260	9821.5360	9821.5560	9821.5860
400 (15 3/4")	15	80	12	50,8	1800	B 19401 9821.5154	9821.5254	9821.5354	9821.5554	9821.5854

Single-Section Brushes Record and Super-Record

Record and Super-Record single-section brushes are produced from various kinds of crimped wire (offering different properties).

We recommend the following approximate peripheral speeds for these brushes: 30 metres per second for steel; 18–20 m/sec. for

non-ferrous metals; 15 m/sec. for plastic.

Fill types: RECORD

LTE – Brass plated steel wire, tempered, single-wire, crimped.

INOX – Stainless steel wire, acid resistant, crimped.

STD – Steel wire, natural hard, crimped.

SUPER-RECORD

ASD – Steel wire, hardened, high tensile strength and tough, crimped.

Applications:

Removing paint and other coatings, including rust and scale from all types of steel work-pieces and oxide layers from stainless steel or non-ferrous metals. Creating metallically clean surfaces. Cleaning

tool dies. Deburring castings. Matt finishing of metal surfaces.

Notes on use:

For narrow section work-pieces and profiles with bench or hand-held machines.

Adapters:

Refer to the bottom of page 49 for details on arbor hole reducing inserts.

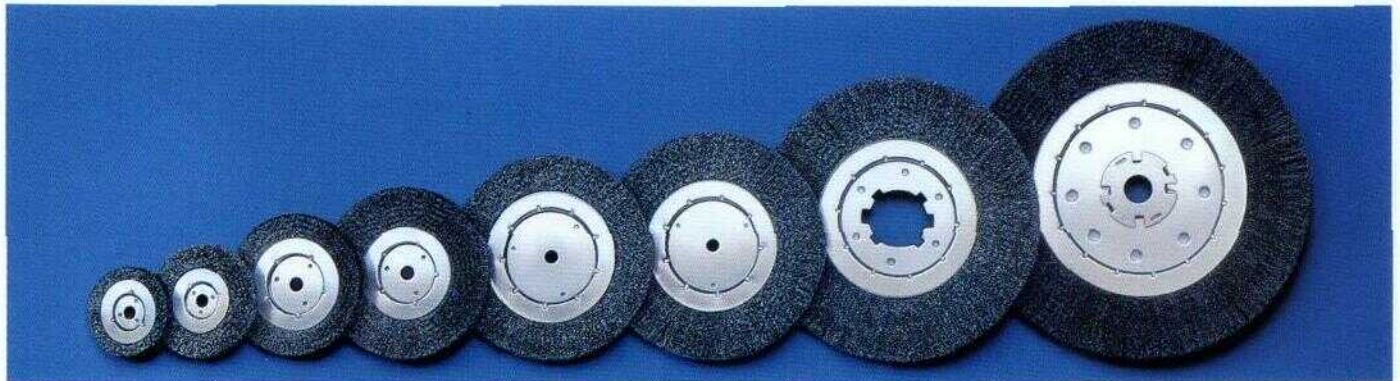

Einzelscheiben-Bürsten Super-Record



Wear eye protection!

Single-Section Brushes Super-Record

Abmessungen/ Dimensions	B	L	d		UPM/ RPM	Type	0.10 ASD	0.15 ASD	0.20 ASD	0.30 ASD	0.35 ASD	0.50 ASD
			min.	max.			Art.-No.	Art.-No.	Art.-No.	Art.-No.	Art.-No.	Art.-No.
100 (4")	11	22	12	20	8000	SR 3101	9831.0117	9831.0217	9831.0317	9831.0517	9831.0617	9831.0817
150 (6")	13	34	12	32	6000	SR 5151	9851.0127	9851.0227	9851.0327	9851.0527	9851.0627	9851.0827
			15	40	6000	SR 6151	9861.0127	9861.0227	9861.0327	9861.0527	9861.0627	9861.0827
180 (7")	13	33	12	50,8	6000	SR 8181	9871.0133	9871.0233	9871.0333	9871.0533	9871.0633	9871.0833
200 (8")	13	43	12	50,8	4500	SR 8201	9871.0137	9871.0237	9871.0337	9871.0537	9871.0637	9871.0837
250 (10")	15	55	12	50,8	3500	SR 10251	9881.0143	9881.0243	9881.0343	9881.0543	9881.0643	9881.0843
300 (12")	17	55	12	50,8	3000	SR 15301	9811.0148	9811.0248	9811.0348	9811.0548	9811.0648	9811.0848
350 (14")	17	55	12	50,8	2400	SR 19351	9821.0153	9821.0253	9821.0353	9821.0553	9821.0653	9821.0853
380 (15")	17	95	12	50,8	2400	SR 15381	9811.0160	9811.0260	9811.0360	9811.0560	9811.0660	9811.0860
400 (15 3/4")	17	80	12	50,8	1800	SR 19401	9821.0154	9821.0254	9821.0354	9821.0554	9821.0654	9821.0854

Reduziereinsätze für d = 50,8

Adapters for d = 50.8

Abmessungen/Dimensions			
d 1 (mm)	10	20	25
Art.-No.	0300.4601	0300.4620	0300.4625
Abmessungen/Dimensions			
d 1 (mm)	30	35	40
Art.-No.	0300.4630	0300.4635	0300.4640

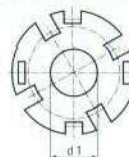

Einzelscheiben-Bürsten Multicord und Delta

2-align

Multicord: Eine Type, die durch die Seilkonstruktion der Drähte noch aggressiver wird. Für sie – und auch für die Delta – werden folgende Umfangsgeschwindigkeiten empfohlen: Für die Bearbeitung von Stahl ca. 30 m/sec, NE-Metall 18–20 m/sec und Kunststoff 15 m/sec.

Besatzarten: MULTICORD

LIT – Stahldraht vermessingt, federhart und zäh, in Seilkonstruktion, gewellt.

Anwendungen:

Entfernen von Gummiresten (Überschußgummi) an Gummi-Metalteilen (Schwingmetallteile), von Kleberesten.

Bearbeitung:

Für schmale Werkstücke und profilierte Oberflächen auf stationären oder in handgeführten Maschinen.

Delta: Die Drähte sind in eine elastische Kunststoffmasse eingebettet und somit extrem aggressiv und langlebig. Bis zum Schluß bleibt eine

exakte Arbeitsbreite bestehen. Zusätzlich bietet sie erhöhte Arbeitssicherheit, da im Kunststoffbett Drahtbruch ausgeschlossen ist.

Besatzart: DELTA

LTE – Stahldraht vermessingt, Einzeldraht, federhart, gewellt.

Anwendungen:

Zum Entfernen von Härtezunder. Zur Schweißnaht-Bearbeitung. Und zum Aufrauen von Metall vor der Beschichtung. Entgraten von Blechkanten.

Bearbeitung:

Siehe Multicord.

Reduziereinsätze:

Für beide – siehe Seite 51 unten.

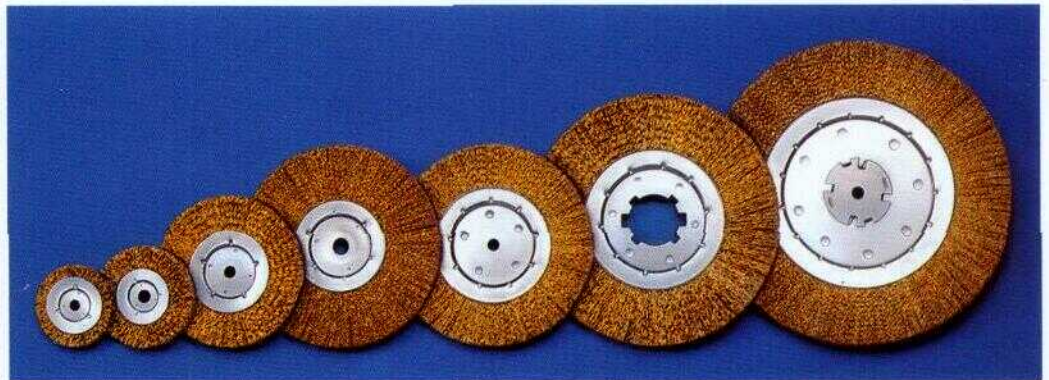

Einzelscheiben-Bürsten Multicord



Wear eye protection!
Type

Single-Section Brushes Multicord

Abmessungen/ Dimensions		d		UPM/ RPM	Type	0.15 LIT	0.20 LIT	0.25 LIT	0.27 LIT	
∅	B	L	min.	max.	max.	Art.-No.	Art.-No.	Art.-No.	Art.-No.	
80 (3")	11	12	12	20	10000	MC 381	9831.1113	9831.1313	9831.1813	9831.1513
100 (4")	11	22	12	20	8000	MC 3101	9831.1117	9831.1317	9831.1817	9831.1517
125 (5")	11	34	12	20	6000	MC 3121	9831.1122	9831.1322	9831.1822	9831.1522
		22	12	32	6000	MC 5121	9851.1122	9851.1322	9851.1822	9851.1522
150 (6")	13	34	12	32	6000	MC 5151	9851.1127	9851.1327	9851.1827	9851.1527
180 (7")	13	49	12	32	6000	MC 5181	9851.1133	9851.1333	9851.1833	9851.1533
		44	12	40	6000	MC 6181	9861.1133	9861.1333	9861.1833	9861.1533
200 (8")	15	54	12	40	4500	MC 6201	9861.1137	9861.1337	9861.1837	9861.1537
		43	12	50,8	4500	MC 8201	9871.1137	9871.1337	9871.1837	9871.1537
250 (10")	15	55	12	50,8	3500	MC 10251	9881.1143	9881.1343	9881.1843	9881.1543
300 (12")	17	55	12	50,8	3000	MC 15301	9811.1148	9811.1348	9811.1848	9811.1548
350 (14")	17	55	12	50,8	2400	MC 19351	9821.1153	9821.1353	9821.1853	9821.1553
380 (15")	17	70	12	50,8	2400	MC 19381	9821.1160	9821.1360	9821.1860	9821.1560
400 (16")	17	80	12	50,8	1800	MC 19401	9821.1154	9821.1354	9821.1854	9821.1554

Single-Section Brushes Multicord and Delta

Multicord: This brush has a particularly aggressive action, thanks to its cablewire construction. We recommend the following approximate peripheral speeds for the Multicord and Delta: **30 m/sec. for steel; 18–20 m/sec. for non-ferrous metals; 15 m/sec. for plastic.**

Fill type: MULTICORD LIT – Brass plated steel wire, tempered and tough, cord construction, crimped.

Applications:
 Removing excess rubber from rubber to metal bonded parts.
 Removing residues of adhesive.

Delta: On the Delta model, which has an extremely aggressive action, the wire is embedded in an elastic synthetic material. This ensures that a precise working width is maintained throughout its long service life. Moreover, the plastic coating eliminates the possibility

of wire breakage, leading to greater working safety.

Fill type: DELTA LTE – Brass plated steel wire, tempered, single-wire, crimped.
Applications:
 Removal of hard scale. Cleaning welds. Surface preparation prior to coating, edge deburring.

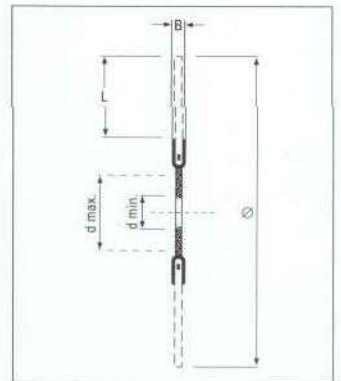

Einzeilscheiben-Bürsten Delta



Wear eye protection!

Single-Section Brushes Delta

Abmessungen/ Dimensions				UPM/ RPM		Type	0.15 LTE	0.30 LTE
∅	B	L	d	d	max.		Art.-No.	Art.-No.
mm	mm	mm	min.	max.				
100 (4")	12	22	12	20	8000	DK-B 3101	9918.1029	9918.1000
125 (5")	14	22	12	32	6000	DK-B 5121	9918.1103	9918.1024
150 (6")	14	34	12	32	6000	DK-B 5151	9918.1007	9918.1001
160 (6 1/4")	14	23	12	50,8	6000	DK-B 8161	9918.1099	9918.1052
200 (8")	14	43	12	50,8	4500	DK-B 8201	9918.1104	9918.1002
250 (10")	16	55	12	50,8	3500	DK-B 10251	9918.1100	9918.1003
300 (12")	18	55	12	50,8	3000	DK-B 15301	9918.1101	9918.1004

Notes on use:

For use on bench or handheld machines.

Adapters:

Refer to the bottom of page 51 for details on arbor hole reducing inserts.

Reduziereinsätze für d = 50,8

Adapters for d = 50.8

Abmessungen/Dimensions					
d 1 (mm)	10	20	25		
Art.-No.	0300.4601	0300.4620	0300.4625		
Abmessungen/Dimensions					
d 1 (mm)	30	35	40		
Art.-No.	0300.4630	0300.4635	0300.4640		

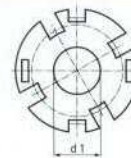

Einzelscheiben-Bürsten Ultra und Plus-Ultra

Einzelstehender Zopf und ölschlußgehärteter Draht machen diese Typen sehr aggressiv. Der gezopfte Besatz ist ideal für höhere Umfangsgeschwindigkeiten. Wir empfehlen 35–40 m/sec. Bitte beachten Sie besonders unser Winkelschleiferprogramm, ausgerüstet mit

Achslot oder M 14-Gewinde (auf Anfrage 5/8"-Gewinde).

Besatzarten:

ULTRA/PLUS-ULTRA

SUP – Stahldraht gehärtet, glatt.

INOX – Stahldraht, nichtrostend und säurebeständig, glatt.

AZD – Stahldraht gehärtet, hart und zäh, glatt.

Anwendungen:

Entfernen von Gummiresten (Überschußgummi) an Gummi-Metall-Teilen (Schwingmetallteile), von Kleberesten, Härtezunder und Lack. Zur Schweißnaht-Bearbeitung.

Bearbeitung:

Für schmale Werkstücke und profilierte Oberflächen auf stationären

oder in handgeführten Maschinen. Die Type PZK im Winkelschleiferprogramm wurde von uns speziell zur Schweißnahtbearbeitung im Pipeline- und Rohrleitungsbau entwickelt.

Reduziereinsätze:

Siehe Seite 53 unten.

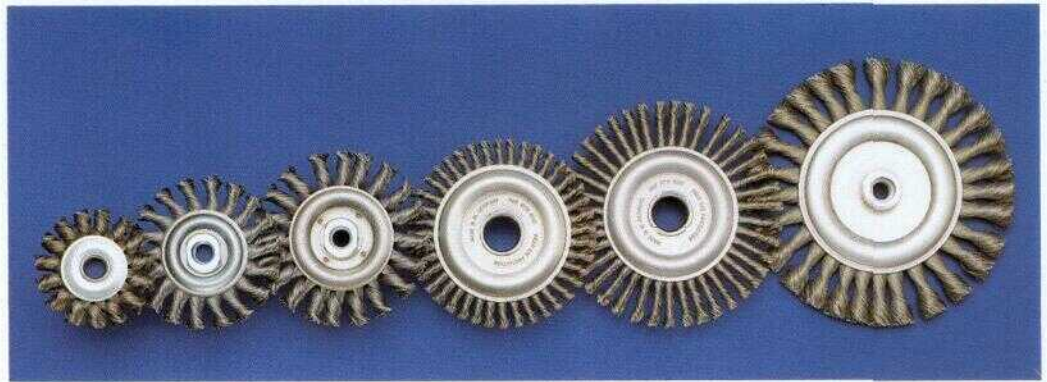
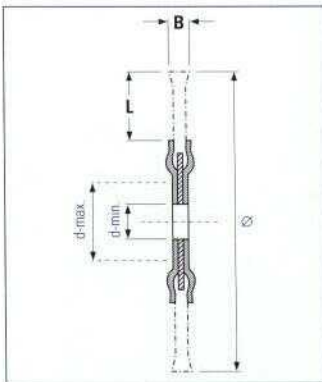

Einzelscheiben-Bürsten Ultra



Wear eye protection!

Single-Section Brushes Ultra

Abmessungen/ Dimensions													
∅	RH	Z*	ZR*	B	L		UPM/ RPM	Type	0.35 SUP	0.50 SUP	0.35 INOX	0.50 INOX	0.50 AZD
mm				mm	mm		max.		Art.-No.	Art.-No.	Art.-No.	Art.-No.	Art.-No.
75 (3")	1	15	R	11	17	d 13	20000	Z 1.3751	9902.1079	9902.1081	9902.1086	9902.1085	-
100 (4")	1	22	R	11	22	d 22,2	11000	Z 2101A	9902.2081	9902.2066	9902.2070	9902.2091	-
100 (4")	1	22	R	11	22	M 14	11000	Z 2101A	9902.2161	9902.2022	9902.2164	9902.2097	-
110 (4 3/8")	2	18	R	13	27	M 14	11000	PZ 2112	-	-	-	-	9902.2013
115 (4 1/2")	1	20	R	11	23	d 12	11000	SZ 2121	9902.2162	9902.2109	9902.2165	9902.2167	-
	1	20	R	11	23	d 22,2	11000	SZ 2121	9902.2075	9902.2068	9902.2098	9902.2071	-
	1	20	R	11	23	M 14	11000	Z 2121A	9902.2082	9902.2083	9902.2112	9902.2096	-
	1	20	L	11	23	d 22,2	11000	SZ 2121	9902.2163	9902.2148	9902.2166	9902.2168	-
125 (5")	1	40	R	6	18	d 22,2	10000	PZK 3121	-	-	-	-	9902.3074
150 (6")	1	40	R	6	30	d 22,2	9000	PZK 3151	-	-	-	-	9902.3095
	1	40	R	6	30	M 14	9000	PZK 3151	-	-	-	-	9902.3177
	1	24	R	12	34	M 14	9000	SZ 3151	9902.3117	9902.3038	9902.3176	9902.3171	-
178 (7")	1	28	L	15	35	d 22,2	9000	SZ 4181	9902.4099	9902.4097	9902.4100	9902.4102	-
	1	28	R	15	44	M 14	9000	SZ 4181	9902.4087	9902.4015	9902.4101	9902.4084	-
	1	52	R	6	36	d 22,2	9000	PZK 4181	-	-	-	-	9902.4045
	1	76	L	5	32	d 22,2	9000	PZK 4181	-	-	-	-	9902.4113

Einzelscheiben-Bürsten Ultra



Wear eye protection!

Single-Section Brushes Ultra

Abmessungen/ Dimensions														
∅	Z*	B	L	d	d		UPM/ RPM	Type	0.35 SUP	0.50 SUP	0.80 SUP	0.35 INOX	0.50 INOX	0.80 INOX
mm		mm	mm	min.	max.	max.			Art.-No.	Art.-No.	Art.-No.	Art.-No.	Art.-No.	Art.-No.
150 (6")	24	12	34	12	32	9000	9000	SZ 3151	9831.8127	9831.8327	9831.8527	9831.7127	9831.7327	9831.7527
180 (7")	28	12	44	-	22,2	9000	9000	SZ 4181	9841.8133	9841.8333	9841.8533	9841.7133	9841.7333	9841.7533
200 (8")	34	12	44	12	50,8	8500	8500	SZ 6201	9861.8137	9861.8337	9861.8537	9861.7137	9861.7337	9861.7537
250 (10")	42	13	54	12	50,8	4500	4500	SZ 8251	9871.8143	9871.8343	9871.8543	9871.7143	9871.7343	9871.7543
	54	13	41	12	50,8	4500	4500	SZ 10251	9881.8143	9881.8343	9881.8543	9881.7143	9881.7343	9881.7543
300 (12")	54	13	63	12	50,8	4500	4500	SZ 10301	9881.8148	9881.8348	9881.8548	9881.7148	9881.7348	9881.7548
	60	13	52	12	50,8	4500	4500	SZ 13301	9891.8148	9891.8348	9891.8548	9891.7148	9891.7348	9891.7548
350 (14")	70	13	60	12	50,8	3600	3600	SZ 15351	9811.8153	9811.8353	9811.8553	9811.7153	9811.7353	9811.7553
380 (15")	70	13	75	12	50,8	3600	3600	SZ 15381	9811.8160	9811.8360	9811.8560	9811.7160	9811.7360	9811.7560

Z* = Anzahl der Zöpfe pro Reihe/Number of knots per row.

ZR* = Zopfrichtung/knot direction: R = rechts/righthand, L = links/lefthand

Single-Section Brushes Ultra and Plus-Ultra

Single twists of oil-hardened wire give these brushes an extremely aggressive action. This twist knot construction allows higher surface speeds, we recommend 35 to 40 m/sec. Please also note our brushes for angle grinders. These are supplied for mounting with an arbor

hole or a M 14 thread (5/8" thread on request).

Fill types: ULTRA/PLUS-ULTRA

SUP – Steel wire, hardened, straight.

INOX – Stainless steel wire, acid resistant, straight.

AZD – Steel wire, hardened, high tensile strength and tough, straight.

Applications:

Removing excess rubber from rubber to metal bonded parts.
Removing residues of adhesive, hard scale rust and paint.
Cleaning welds.

Notes on use:

For use on bench or handheld machines.

The type PZK from our range for angle grinders has been specially developed for weld cleaning and descaling when laying the pipes.

Adapters:

Refer to the bottom of page 53 for details on arbor hole reducing inserts.



Einzeilscheiben-Bürsten Plus-Ultra



Wear eye protection!

Single-Section Brushes Plus-Ultra

Abmessungen/ Dimensions						UPM/ RPM	Type	0.35 AZD	0.50 AZD	0.80 AZD
∅	Z*	B	L	d	d			Art.-No.	Art.-No.	Art.-No.
mm		mm	mm	min.	max.	max.				
150 (6")	24	12	34	12	32	9000	PZ 3151	9831.9127	9831.9327	9831.9527
180 (7")	28	12	43	-	22,2	9000	PZ 4181	9841.9133	9841.9333	9841.9533
200 (8")	34	12	44	12	50,8	8500	PZ 6201	9861.9137	9861.9337	9861.9537
250 (10")	42	13	54	12	50,8	4500	PZ 8251	9871.9143	9871.9343	9871.9543
	54	13	41	12	50,8	4500	PZ 10251	9881.9143	9881.9343	9881.9543
300 (12")	54	13	63	12	50,8	4500	PZ 10301	9881.9148	9881.9348	9881.9548
	60	13	52	12	50,8	4500	PZ 13301	9891.9148	9891.9348	9891.9548
350 (14")	70	13	60	12	50,8	3600	PZ 15351	9811.9153	9811.9353	9811.9553
380 (15")	70	20	78	12	50,8	3600	PZ 15381	9811.9160	9811.9360	9811.9560

Z* = Anzahl der Zöpfe pro Reihe/Number of knots per row.

Bürstentechnik im Recycling: z.B. beim Abtrennen der Deckel von Aludosen.

Brush technology used in recycling, for example to remove the tops of aluminium cans.

Reduziereinsätze für d = 50,8

Adapters for d = 50.8

Abmessungen/Dimensions			
d 1 (mm)	10	20	25
Art.-No.	0300.4601	0300.4620	0300.4625
Abmessungen/Dimensions			
d 1 (mm)	30	35	40
Art.-No.	0300.4630	0300.4635	0300.4640

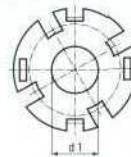

Einzelscheiben-Bürsten Alpha

Die Vorteile der ANDERLON-Schleifborste: Sie ist hitzestabilisiert und durchgehend mit 20–40% Schleifkörnern angereichert. Somit sind eine kontinuierliche Schleifwirkung und sehr hohe Standzeiten gewährleistet. **KULLEN** verwendet eben nur das Beste. Weitere Korngrößen und Borstendurchmesser auf Anfrage. Wir empfehlen eine Umfangsgeschwindigkeit von 15–20 m/sec.

Besatzarten: ALPHA

ANA – ANDERLON-Schleifborsten mit Aluminium-Oxyd-Korn, gewellt.

ANS – ANDERLON-Schleifborsten mit Silicium-Carbid-Korn, gewellt.

Anwendungen:

Entgraten von Kurbelwellen, Zylinderköpfen, Trennflächen und Außenkonturen an Pleueln, Achs-Schenkeln,

Getriebedeckeln, Dichtflächen an Zylinderköpfen und Ölwanne, Bearbeitungsgrat an Vergaserteilen, Ventilkörpern. Weiterhin zum Entgraten von Zahn- und Kegelrädern. Generell in der Automobil-, Zubehör-, Motoren- und Flugzeugbau-Industrie zum Entgraten von Stahl- und NE-Metalteilen.

Bearbeitung:

In vollautomatisierten Entgratmaschinen, in Centerless-Entgratmaschinen sowie Robotern.

Reduziereinsätze:

Siehe Seite 55 unten.

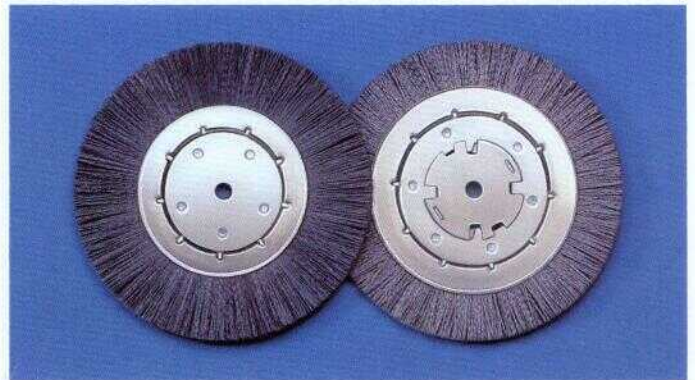
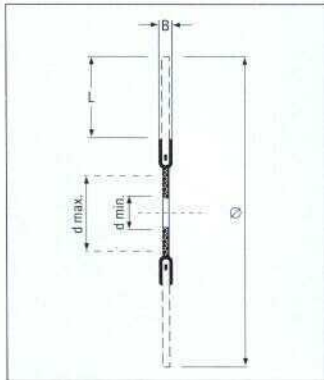

Einzelscheiben-Bürsten Alpha



Wear eye protection!

Single-Section Brushes Alpha

Abmessungen/ Dimensions		UPM/ RPM		Type	Type AS = ANS Type AA = ANA								
∅	B	L	d	d		500/0.45	320/0.55	180/0.90	120/0.55	120/1.00	80/1.00	80/1.27	
mm	mm	mm	min.	max.	max.	Art.-No.	Art.-No.	Art.-No.	Art.-No.	Art.-No.	Art.-No.	Art.-No.	
80 (3")	11	17	12	20	12000	AS 381	9831.3613	9831.3713	9831.3813	9945.0452	9831.3913	9945.0196	9831.3013
	11	17	12	20	12000	AA 381	9831.3113	9831.3213	9831.3313	-	9831.3413	9945.0447	-
100 (4")	11	22	12	20	12000	AS 3101	9831.3617	9831.3717	9831.3817	9945.0480	9831.3917	9945.0149	9831.3017
	11	22	12	20	12000	AA 3101	9831.3117	9831.3217	9831.3317	-	9831.3417	9945.0337	-
125 (5")	13	22	12	32	10000	AS 5121	9851.3622	9851.3722	9851.3822	9945.0757	9851.3922	9945.0764	9851.3022
	11	35	12	20	10000	AS 3121	9831.3622	9831.3722	9831.3822	9945.0618	9831.3922	9945.0466	9831.3022
	13	22	12	32	10000	AA 5121	9851.3122	9851.3222	9851.3322	-	9851.3422	9945.0765	-
150 (6")	11	35	12	20	10000	AA 3121	9831.3122	9831.3222	9831.3322	-	9831.3422	9945.0766	-
	15	29	12	40	8000	AS 6151	9861.3627	9861.3727	9861.3827	9945.0283	9861.3927	9945.0163	9861.3027
	13	34	12	32	8000	AS 5151	9851.3627	9851.3727	9851.3827	9945.0143	9851.3927	9945.0148	9851.3027
	15	29	12	40	8000	AA 6151	9861.3127	9861.3227	9861.3327	-	9861.3427	9945.0355	-
180 (7")	13	34	12	32	8000	AA 5151	9851.3127	9851.3227	9851.3327	-	9851.3427	9945.0437	-
	13	32	12	50,8	6000	AS 8181	9871.3633	9871.3733	9871.3833	9945.0285	9871.3933	9945.0767	9871.3033
	15	44	12	40	6000	AS 6181	9861.3633	9861.3733	9861.3833	9945.0539	9861.3933	9945.0277	9861.3033
	13	32	12	50,8	6000	AA 8181	9871.3133	9871.3233	9871.3333	-	9871.3433	9945.0768	-
15	44	12	40	6000	AA 6181	9861.3133	9861.3233	9861.3333	-	9861.3433	9945.0769	-	

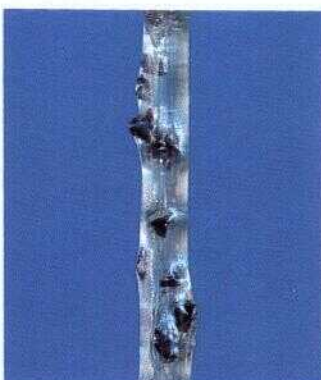

Mikroskopische Abbildung einer ANDERLON-Schleifborste mit Silicium-Carbid-Korn.

Microscopic view of an ANDERLON grinding filament with silicon carbide grit.

Single-Section Brushes Alpha

Anderlon abrasive nylon filaments combine the advantages of a grinding action, strength, flexibility and an excellent service life. This is because the heat resistant nylon is mixed with 20 to 40% abrasive grit before extrusion to produce a filament which is impregnated

throughout its structure. Different grit sizes and filament diameters are available in either silicon carbide or aluminium oxide recommended surface speed 15 to 20 metres per second.

Fill types: ALPHA

ANA – ANDERLON abrasive filaments, aluminiumoxide-grit, crimped.

ANS – ANDERLON abrasive filaments, silicon-carbide grit, crimped.

Applications:

Deburring crankshafts, cylinder heads, axle joints, gearbox housings,

carburettor components, valve bodies, gears, the mating surfaces and external contours of connecting rods, and the sealing surfaces of cylinder heads or sumps. General deburring of steel and non-ferrous-metal components in the auto-mobile accessory, engine-building and aviation industries.

Notes on use:

For fully-automatic deburring machines, centreless deburring machines and robots.

Adapters:

Refer to the bottom of page 55 for details on arbor hole reducing inserts.

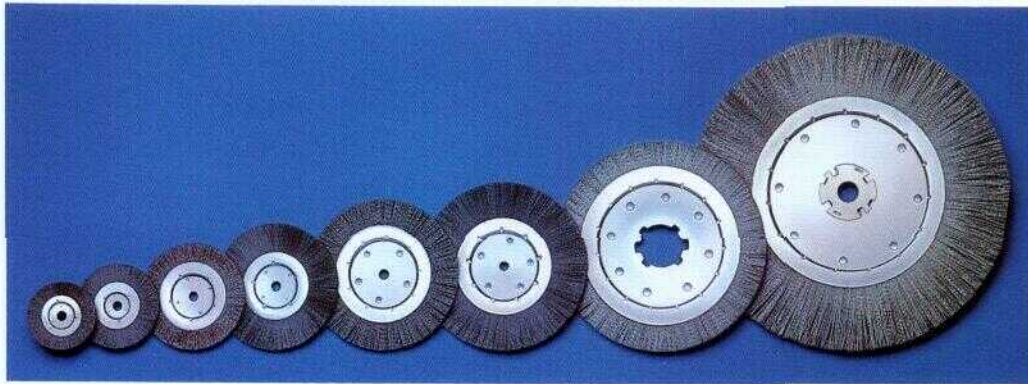

Einzelscheiben-Bürsten Alpha



Wear eye protection!

Single-Section Brushes Alpha

Abmessungen/ Dimensions	B	L	d	UPM/ RPM	Type	Type AS = ANS Type AA = ANA						
						500/0.45	320/0.55	180/0.90	120/0.55	120/1.00	80/1.00	80/1.27
∅	mm	mm	max.	max.		Art.-No.	Art.-No.	Art.-No.	Art.-No.	Art.-No.	Art.-No.	Art.-No.
200 (8")	15	30	50,8*	6000	AS 10201	9881.3637	9881.3737	9881.3837	9945.0778	9881.3937	9945.0186	9881.3037
	13	43	50,8*	6000	AS 8201	9871.3637	9871.3737	9871.3837	9945.0274	9871.3937	9945.0192	9871.3037
	15	30	50,8*	6000	AA 10201	9881.3137	9881.3237	9881.3337	-	9881.3437	9945.0770	-
250 (10")	13	43	50,8*	6000	AA 8201	9871.3137	9871.3237	9871.3337	-	9871.3437	9945.0771	-
	17	30	50,8*	3600	AS 15251	9811.3643	9811.3743	9811.3843	9945.0296	9811.3943	9945.0158	9811.3043
	15	55	50,8*	3600	AS 10251	9881.3643	9881.3743	9881.3843	9945.0781	9881.3943	9945.0428	9881.3043
300 (12")	17	30	50,8*	3600	AA 15251	9811.3143	9811.3243	9811.3343	-	9811.3443	9945.0772	-
	15	55	50,8*	3600	AA 10251	9881.3143	9881.3243	9881.3343	-	9881.3443	9945.0773	-
	19	30	50,8*	3000	AS 19301	9821.3648	9821.3748	9821.3848	9945.0111	9821.3948	9821.3548	9821.3048
350 (14")	17	55	50,8*	3000	AS 15301	9811.3648	9811.3748	9811.3848	9945.0784	9811.3948	9811.3548	9811.3048
	19	30	50,8*	3000	AA 19301	9821.3148	9821.3248	9821.3348	-	9821.3448	9945.0774	-
	17	55	50,8*	3000	AA 15301	9811.3148	9811.3248	9811.3348	-	9811.3448	9945.0775	-
380 (15")	19	55	50,8*	2400	AS 19351	9821.3653	9821.3753	9821.3853	9945.0787	9821.3953	9821.3553	9821.3053
	19	55	50,8*	2400	AA 19351	9821.3153	9821.3253	9821.3353	-	9821.3453	9945.0776	-
380 (15")	19	70	50,8*	1800	AS 19381	9821.3660	9821.3760	9821.3860	9945.0789	9821.3960	9945.0427	9821.3060
	19	70	50,8*	1800	AA 19381	9821.3160	9821.3260	9821.3360	-	9821.3460	9945.0777	-

Reduziereinsätze für d = 50,8

Abmessungen/Dimensions	d 1 (mm)		
d 1 (mm)	10	20	25
Art.-No.	0300.4601	0300.4620	0300.4625
Abmessungen/Dimensions	d 1 (mm)		
d 1 (mm)	30	35	40
Art.-No.	0300.4630	0300.4635	0300.4640

Adapters for d = 50.8

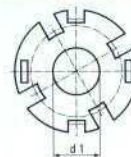

SH-Rundbürsten
SH-Circular Brushes



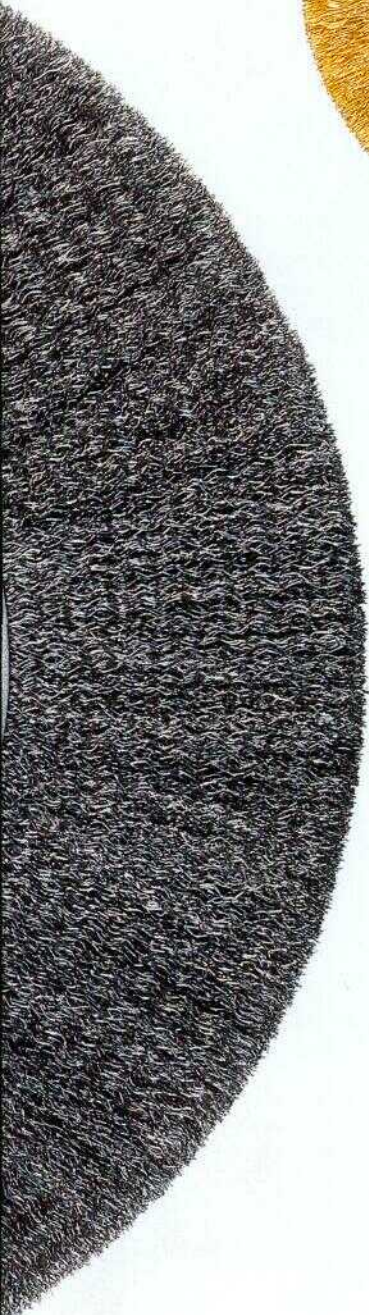

SH-Rundbürsten
SH-Circular Brushes
RECORD/MULTICORD 58

SH-Rundbürsten
SH-Circular Brushes
ULTRA/DELTA/ALPHA 60

SH-Rundbürsten Record und Multicord

Wenn es auf größtmögliche Besatzdichte ankommt, sind SH-Rundbürsten nicht zu schlagen. Sie werden in Einzelring-Ausführung gefertigt und können entweder einzeln auf einer Welle montiert werden oder in beliebiger Arbeitsbreite, z. B. zu Walzenbürsten, aneinandergereiht werden.

Besatzarten: RECORD
STD – Stahldraht naturhart, gewellt.
INOX – Stahldraht, nichtrostend und säurebeständig, gewellt.
LTE – Stahldraht vermessingt, Einzeldraht, federhart, gewellt.

Multicord: Durch die Seilkonstruktion der Drähte sind diese Typen noch aggressiver.

Besatzart: MULTICORD
LIT – Stahldraht vermessingt, federhart und zäh, in Seilkonstruktion, gewellt.

Anwendungen:
 Zum Entfernen von Oxydschichten und Lacken. Zum Aufrauhen und Entgraten.

Bearbeitung:
 Auf biegsamen Wellen oder in stationären Maschinen.

Record: Record SH-Rundbürsten werden mit gewellten Drähten in verschiedenen Qualitäten gefertigt.

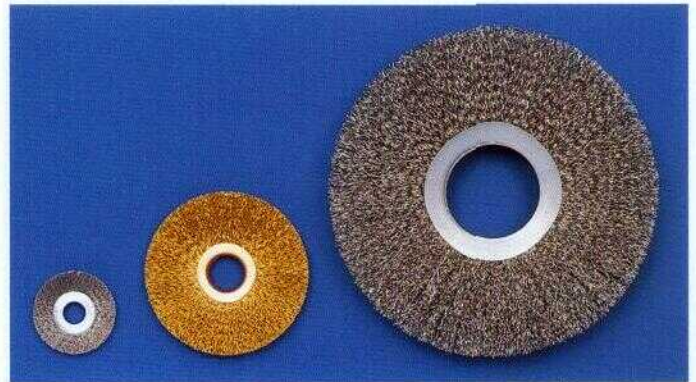
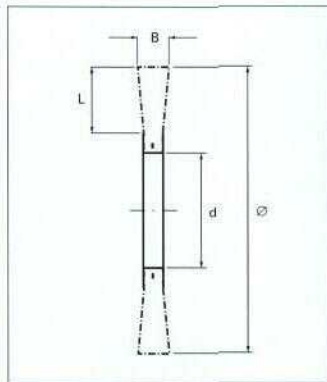

SH-Rundbürsten Record



Wear eye protection!

SH-Circular Brushes Record

Abmessungen/ Dimensions				UPM/ RPM	Type						
Ø	B	L	d			0.20 STD	0.30 STD	0.20 INOX	0.30 INOX	0.15 LTE	0.30 LTE
mm	mm	mm	mm	max.	Art.-No.	Art.-No.	Art.-No.	Art.-No.	Art.-No.	Art.-No.	
40 (1 1/2")	7	11	12,8	20000	SH 401	9949.2140	9949.2141	9949.2142	9949.2143	9949.2131	9949.2066
50 (2")	7	11	16	15000	SH 501	9949.0199	9949.0200	9949.0201	9949.0202	9949.0161	9949.0203
63 (2 1/2")	7	18	16	15000	SH 631	9949.0163	9949.0204	9949.0205	9949.0206	9949.0067	9949.0207
75 (3")	7,4	24	16	12000	SH 751	9949.0208	9949.0209	9949.0210	9949.0211	9949.0062	9949.0212
80 (3 1/4")	6	22	22	10000	SH 2280	9120.0313	9120.0513	9120.4313	9120.4513	9120.5213	9120.5513
100 (4")	7	25	32	8000	SH 32100	9130.0317	9130.0517	9130.4317	9130.4517	9130.5217	9130.5517
150 (6")	8	44	42	6000	SH 42150	9140.0327	9140.0527	9140.4327	9140.4527	9140.5227	9140.5527
180 (7")	8	52,5	53	5000	SH 53180	9150.0333	9150.0533	9150.4333	9150.4533	9150.5233	9150.5533
200 (8")	8	58	62,5	4500	SH 62200	9160.0337	9160.0537	9160.4337	9160.4537	9160.5237	9160.5537
250 (10")	9	70	83	3500	SH 83250	9170.0343	9170.0543	9170.4343	9170.4543	9170.5243	9170.5543
300 (12")	10	85	103	3000	SH 103300	9180.0348	9180.0548	9180.4348	9180.4548	9180.5248	9180.5548
350 (14")	12	82	150	2400	SH 150350	9600.1142	9600.1121	9600.1143	9600.1144	9600.1145	9600.1146
400 (16")	12	87	190	1800	SH 190400	9600.1147	9600.1148	9600.1149	9600.1150	9600.1151	9600.1152



SH-Rundbürste mit Adapter EK.

SH-circular brush with EK adapter.

SH-Rundbürste mit Adapter VDS.

SH-circular brush with VDS adapter.

Reduziereinsätze für Record und Multicord Adapters for Record and Multicord

für Type for Type	d1 min.	d1 max.	Type	Art.-No.
SH/MC-SH 53180	12	40	EK 5	0300.4115
SH/MC-SH 83250	16	60	EK 8	0300.4116
SH/MC-SH 103300	10	80	VDS 103	0300.4763
SH/MC-SH 150350	20	130	VDS 150	0300.4769
SH/MC-SH 190400	20	160	VDS 190	0300.4774

SH-Circular Brushes Record and Multicord

SH-circular brushes can be easily mounted on a variety of roller core designs and as adjacent sections can be placed to build up any working surface width with the highest density fill, or can be mounted singly on a shaft.

Record: SH-circular brushes Record are produced from crimped wire in various qualities.

Fill types: RECORD

STD – Steel wire, natural hard, crimped.

INOX – Stainless steel wire, acid resistant, crimped.

LTE – Brass plated steel wire, tempered, single-wire, crimped.

Multicord: This model has a particularly aggressive action, thanks to its cable-wire construction.

Fill type: MULTICORD

LIT – Brass plated steel wire, tempered and tough, cord construction, crimped.

Applications:

Removing paint and other coatings, including rust and scale.

For roughening and deburring.

Notes on use:

On flexible shafts or bench-type machines.

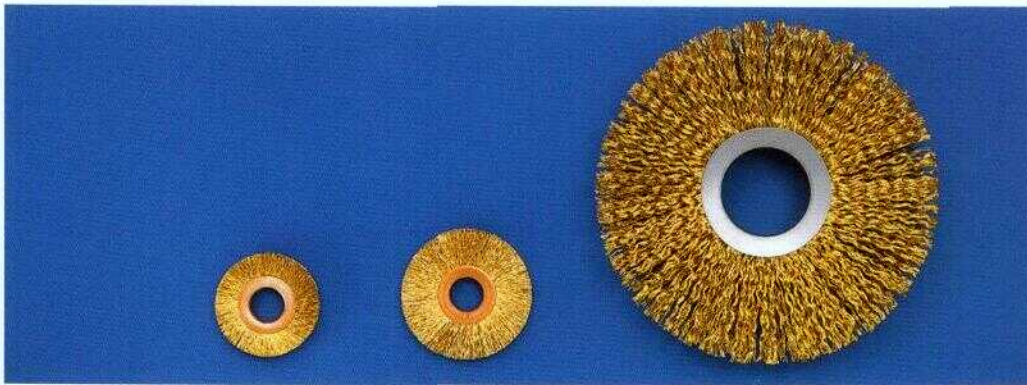

SH-Rundbürsten Multicord



SH-Circular Brushes Multicord

Abmessungen/ Dimensions				UPM/ RPM	Type	0.15 LIT	0.20 LIT	0.25 LIT	0.27 LIT
∅	B	L	d			Art.-No.	Art.-No.	Art.-No.	Art.-No.
mm	mm	mm	mm	max.					
50 (2")	7	11	16	15000	MC-SH 501	9949.0191	9949.0192	9949.0160	9949.0193
63 (2 1/2")	7	18	16	15000	MC-SH 631	9949.0194	9949.0195	9949.0159	9949.0196
75 (3")	7,4	24	16	12000	MC-SH 751	9949.0033	9949.0197	9949.0121	9949.0198
80 (3 1/4")	6	22	22	10000	MC-SH 2280	9120.7113	9120.7313	9120.7413	9120.7513
100 (4")	7	25	32	8000	MC-SH 32100	9130.7117	9130.7317	9130.7817	9130.7517
150 (6")	8	44	42	6000	MC-SH 42150	9140.7127	9140.7327	9140.7827	9140.7527
180 (7")	8	52,5	53	5000	MC-SH 53180	9150.7133	9150.7333	9150.7833	9150.7533
200 (8")	8	58	62,5	4500	MC-SH 62200	9160.7137	9160.7337	9160.7837	9160.7537
250 (10")	9	70	83	3500	MC-SH 83250	9170.7143	9170.7343	9170.7843	9170.7543
300 (12")	10	85	103	3000	MC-SH 103300	9180.7148	9180.7348	9180.7848	9180.7548
350 (14")	12	82	150	2400	MC-SH 150350	9600.1134	9600.1135	9600.1136	9600.1137
400 (16")	12	87	190	1800	MC-SH 190400	9600.1138	9600.1139	9600.1140	9600.1141

SH-Rundbürsten Ultra/Delta/Alpha

Auch diese Typen werden in Einzelring-Ausführung gefertigt und können entweder einzeln auf einer Welle montiert oder in beliebiger Arbeitsbreite, z. B. zu Walzenbürsten (speziell Typ Ultra), zusammengesetzt werden.

Ultra: Einzelstehender Zopf und ölschlußgehärteter Draht sorgen für hohe Aggressivität.

Besatzarten: ULTRA

SUP – Stahldraht gehärtet, glatt.

INOX – Stahldraht, nichtrostend und säurebeständig, glatt.

AZD – Stahldraht gehärtet, hart und zäh, glatt.

Anwendungen:

Aggressive Oberflächenbearbeitung, entgraten und entzundern.

Bearbeitung:

In stationären Maschinen.

Delta: Die Drähte sind in eine elastische Kunststoffmasse eingebettet und somit extrem aggressiv und langlebig.

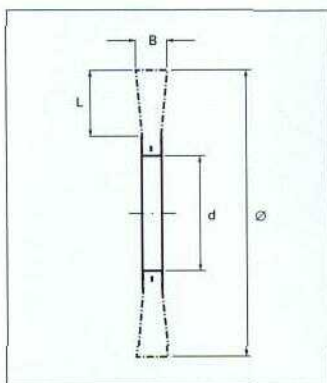

Besatzart: DELTA

LTE – Stahldraht vermessingt, Einzeldraht, federhart, gewellt.

Anwendungen:

Aggressive Oberflächenbearbeitung, entgraten und entzundern.

Alpha: Ihre ANDERLON-Schleifborsten sind hitzestabilisiert und durchgehend

mit 20–40 % Schleifkörnern durchsetzt.

Besatzart: ALPHA

ANS – ANDERLON-Schleifborsten mit Silicium-Carbid-Korn, gewellt.

Anwendungen: Zum Entgraten.

Bearbeitung: DELTA/ALPHA

Auf biegsamen Wellen oder in stationären Maschinen.

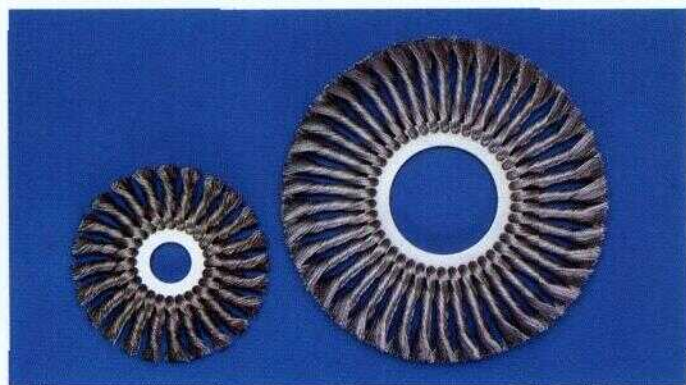

SH-Rundbürsten Ultra



Wear eye protection!

SH-Circular Brushes Ultra

Abmessungen/ Dimensions				UPM/ RPM	Type	0.35 SUP	0.50 SUP	0.35 INOX	0.50 INOX	0.35 AZD	0.50 AZD
∅	B	L	d	max.		Art.-No.	Art.-No.	Art.-No.	Art.-No.	Art.-No.	Art.-No.
200 (8")	16	49	62	8500	Z-SH 62200	9906.0148	9906.0149	9906.0150	9906.0151	9906.0152	9906.0153
250 (10")	18	64	83	4500	Z-SH 83250	9906.0154	9906.0155	9906.0156	9906.0157	9906.0158	9906.0159
300 (12")	20	62	130	3500	Z-SH 130300	9906.0113	9906.0160	9906.0161	9906.0162	9906.0163	9906.0164

SH-Circular Brushes Ultra/Delta/Alpha

Ultra: These models have an especially aggressive action because they are made from straight oil-hardened wire which is twisted to form individual knots.

Fill types: ULTRA

SUP – Steel wire, hardened, straight.

INOX – Stainless steel wire, acid resistant, straight.

AZD – Steel wire, hardened, high tensile strength and tough, straight.

Applications:

Aggressive surface treatment, deburring and removal of scale.

Notes on use:

On bench-type machines.

Delta: Embedded in flexible plastic, the wires of these brushes offer an extremely aggressive action and long service life.

Fill type: DELTA

LTE – Brass plated steel wire, tempered, single-wire, crimped.

Applications:

Aggressive surface treatment, deburring and removal of scale.

Notes on use:

For use on bench or handheld machines.

Alpha: Heat-resistant polyamide filaments, impregnated, with 20–40% abrasive grit.

Fill type: ALPHA

ANS – ANDERLON abrasive filaments, silicon-carbide grit, crimped.

Application:

For deburring.

Notes on use:

For use on bench or handheld machines.



SH-Rundbürsten Delta



Wear eye protection!

SH-Circular Brushes Delta

Abmessungen/ Dimensions				UPM/ RPM	Type	0.15 LTE	0.20 LTE	0.30 LTE	0.35 LTE
∅	B	L	d	max.		Art.-No.	Art.-No.	Art.-No.	Art.-No.
30 (1 1/4")	7	6	10	20000	DK-SH 301	9918.0045	9918.0037	9918.0020	9918.0046
40 (1 1/2")	7	11	10	20000	DK-SH 401	9918.0047	9918.0048	9918.0019	9918.0049
50 (2")	7	14	12,8	15000	DK-SH 501	9918.0033	9918.0025	9918.0009	9918.0017
63 (2 1/2")	7	20	12,8	15000	DK-SH 631	9918.0026	9918.0050	9918.0044	9918.0005
75 (2 7/8")	7,4	24	16	15000	DK-SH 751	9918.0051	9918.0022	9918.0052	9918.0007

SH-Rundbürsten Alpha



Wear eye protection!

SH-Circular Brushes Alpha

Abmessungen/ Dimensions				UPM/ RPM	Type	ANS 320/0.55	ANS 180/0.90	ANS 120/1.00
∅	B	L	d	max.		Art.-No.	Art.-No.	Art.-No.
38 (1 1/2")	10	8	12,8	20000	AS-SH 381	9949.2060	9949.2038	9949.2077
51 (2")	10	11	16	15000	AS-SH 511	9949.0046	9949.0075	9949.0003
63 (2 1/2")	10	18	16	15000	AS-SH 631	9949.0048	9949.0065	9949.0049
75 (2 7/8")	10	24	16	15000	AS-SH 751	9949.0188	9949.0214	9949.0083

Handbürsten Scratch Brushes

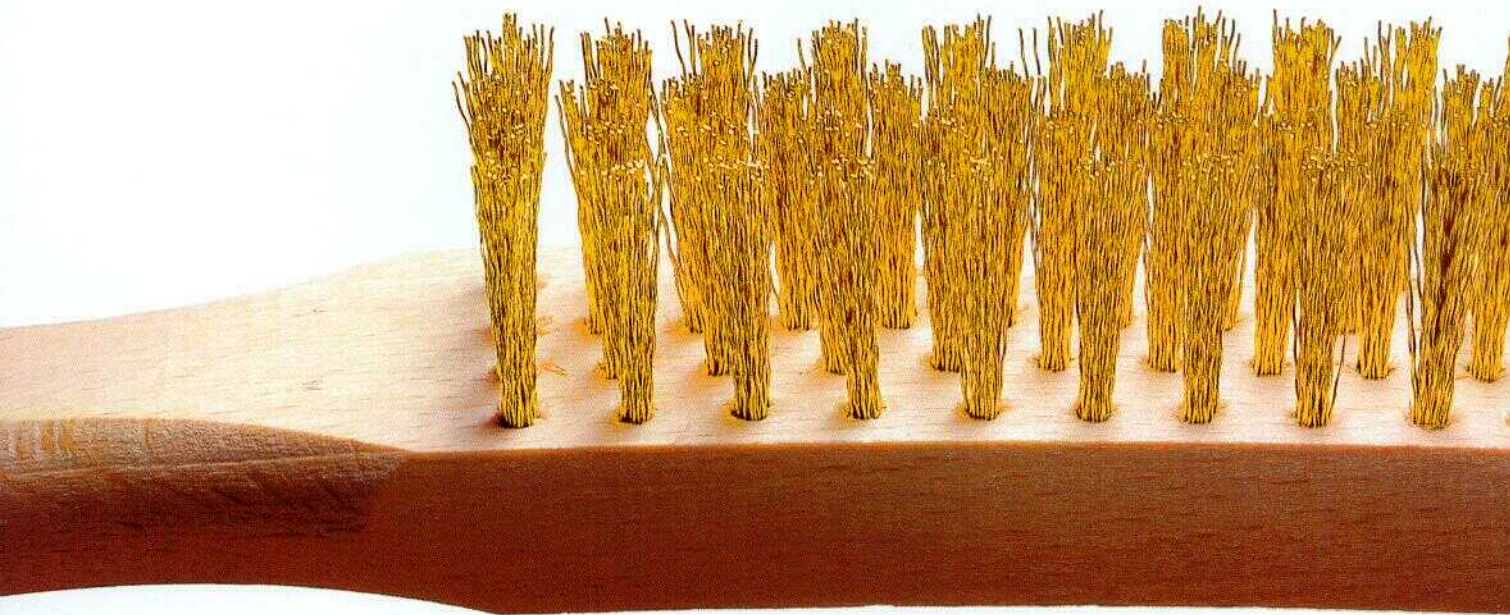

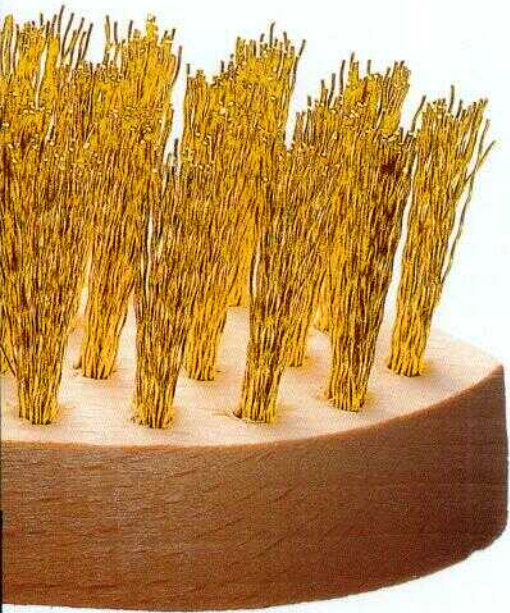

**Draht- und Spid-
Handbürsten
Scratch Brushes
and Spid-Scratch
Brushes** 64

**Feilen- und
Zündkerzenbürsten
Spark Plug Brushes
and File Cleaners** 65

Draht- und SSHB-Handbürsten, Feilen- und Zündkerzenbürsten

Drahthandbürsten mit Holzkörper sind in verschiedenen Arbeitsbreiten (Reihenzahlen) lieferbar. SSHB-Bürsten haben eine schmalere Arbeitsfläche für Feinarbeiten speziell in Vertiefungen profilierter Oberflächen.

Besatzarten: HB

OSG – Stahldraht gehärtet, glatt.

INOX – Stahldraht, nichtrostend und säurebeständig, glatt.

MES – Messing-Draht (Cu-Sn), gewellt.

Besatzarten: SSHB

LTE – Stahldraht vermessingt, Einzeldraht, federhart, gewellt.

INOX – Stahldraht, nichtrostend und säurebeständig, gewellt.

Anwendungen:

Reinigen, entrostern, entlacken, verputzen.

Zündkerzenbürsten sorgen dafür, daß es richtig funkt.

Besatzarten: ZK

BES – Bessemer Stahldraht, gewellt.

MES – Messingdraht (Cu-Zn), gewellt.

Anwendungen:

Zum Reinigen elektrischer Kontakte, speziell an Zündkerzen.

Feilenbürsten haben einen Holzkörper und als Arbeits-

fläche ein aufgeklebtes Feilenbürstenband.

Besatzart: HB

OSG – Stahldraht gehärtet, glatt.

Anwendungen:

Speziell zum Reinigen von Holz- und Metallfeilen.

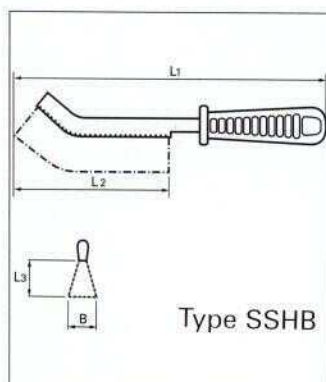
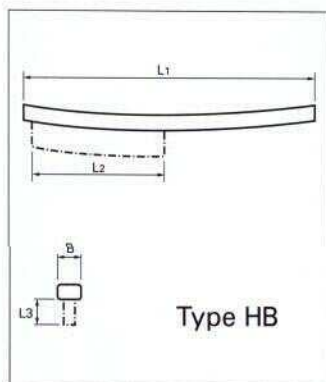
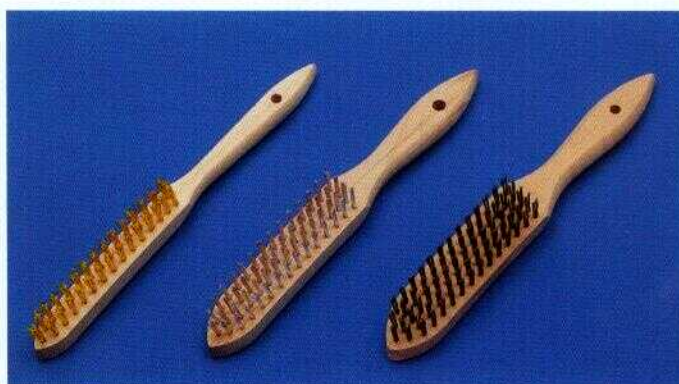

Drahthandbürsten



Wear eye protection!

Scratch Brushes

Abmessungen/
Dimensions

Type

L1	B	RH	L2	L3		0.30 OSG	0.30 INOX	0.30 MES
mm	mm		mm	mm		Art.-No.	Art.-No.	Art.-No.
290	22	2	140	25	HB 120	4093.0019	4093.0021	4093.0024
290	28	3	140	25	HB 130	4093.0025	4093.0027	4093.0030
290	32	4	140	25	HB 140	4093.0001	4093.0007	4093.0002
290	38	5	140	25	HB 150	4093.0037	4093.0039	4093.0003

SSHB-Handbürsten



Wear eye protection!

SSHB-Scratch Brushes

Abmessungen/
Dimensions

Type

L1	B	RH	L2	L3		0.30 LTE	0.30 INOX
mm	mm		mm	mm		Art.-No.	Art.-No.
265	28	1	140	25	SSHB	4099.6457	4099.6492

Scratch Brushes, SSHB-Scratch Brushes, Spark Plug Brushes and File Cleaners

Scratch brushes with wooden core are available in different working widths (number of rows). SSHB-scratch brushes are designed for use for narrow section workpieces or profiled surfaces.

Fill types: HB
OSG – Steel wire, hardened, straight.
INOX – Stainless steel wire, acid resistant, straight.
MES – Brass wire (Cu-Zn), crimped.

Fill types: SSHB
LTE – Brass plated steel wire, tempered, single-wire, crimped.
INOX – Stainless steel wire, acid resistant, crimped.
Applications:
 Cleaning, rust removal and paint removal.

Spark plug brushes ensure that the sparks stay bright.

Fill types: ZK
BES – Bessemer steel wire, crimped.
MES – Brass wire (Cu-Zn), crimped.
Application:
 Cleaning of sparking plugs.

File cleaners are produced from wooden corps and carding band.

Fill type: HB
OSG – Steel wire, hardened, straight.
Applications:
 Specially for cleaning of wood-working and metalworking files.

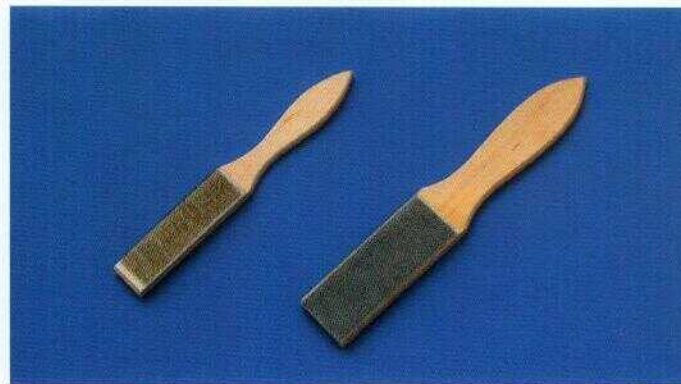
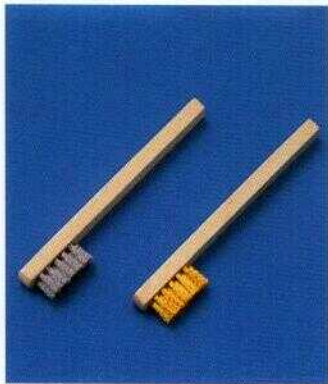

Zündkerzenbürsten



Wear eye protection!

Spark Plug Brushes

Abmessungen/
Dimensions

L1	B	RH	L2	L3	Type	0.15 BES	0.15 MES
mm	mm		mm	mm		Art.-No.	Art.-No.
145	18	3	35	15	ZK 38	4038.1001	4038.1000

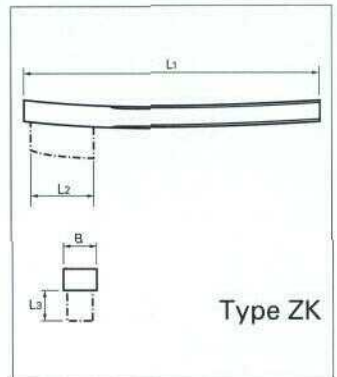

Feilenbürsten



Wear eye protection!

File Cleaners

Abmessungen/
Dimensions

B	Type	OSG
mm		Art.-No.
25	HB 32	4038.0003
40	HB 34	4038.0002
53	HB 35	4038.0001

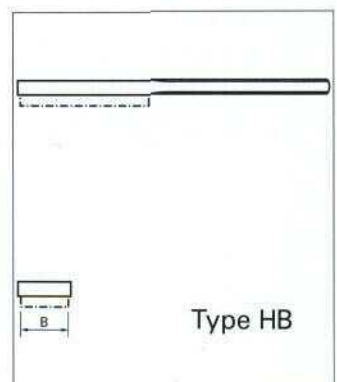

Informationen zu wichtigen Anwendungen

Als einziges Werkzeug mit einer flexiblen Oberfläche sind Bürsten zu einem der vielseitigsten Helfer für fast alle Industriezweige geworden. Richtig genutzt und eingesetzt, bieten sie für viele Produktionsprobleme die wirtschaftlichste Lösung. Eine Vielzahl von Anwen-

dungen und Bürstenlösungen finden Sie in diesem Katalog. Daneben gibt es aber Spezialanwendungen, über die wir Sie auf Wunsch gern gesondert informieren.

Bei der Metallbearbeitung zum Beispiel ist die Gratbildung immer ein „heißes Eisen“. Wenn Sie keine

Qualitätsverluste in Kauf nehmen wollen, müssen Sie für effiziente Entgrat-Technik sorgen. Bürsten von KULLEN gewährleisten Ihnen, daß dabei alles glatt geht. Fordern Sie unsere Spezial-Informationen über Schnitkantentgraten und Automatisches Entgraten an.

Und wenn Sie gezieltere Fragen haben oder eine ausführliche Beratung über Ihre spezifischen Anwendungsfälle benötigen, erwarten unsere Fachberater gerne Ihren Anruf:

Telefon +49 (0) 71 21/142-0.



Eine Walzenbürste mit ANS-Besatz entgratet diese Hartmetall-Wendepplatten auf einer Rundtisch-Entgratmaschine.

A roller brush with ANS fill material being used to deburr carbide cutters on a rotary-table deburring machine.

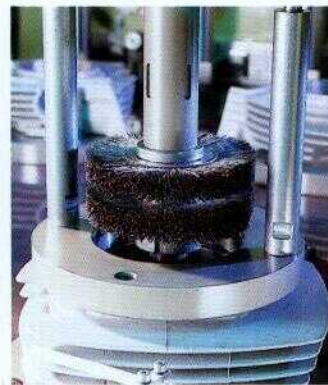

Hier entgratet eine Alpha-Einzelscheibenbürste einen Zylinderkopf.

Here, an Alpha single-section brush is being used to deburr a cylinder head.

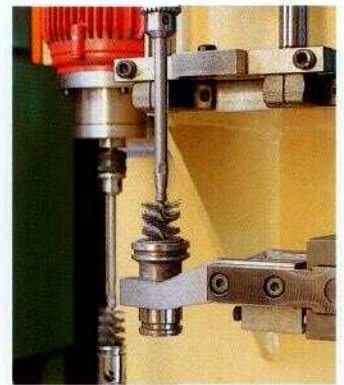

Eine Innenbürste entgratet Querbohrungen in einem Ventilkörper.

An interior brush being used to deburr lateral bores in a valve body.



Eine Alpha-Einzelscheibenbürste bearbeitet ein Kegelrad aus Stahl.

An Alpha single-section brush being used to deburr a steel tapered wheel.

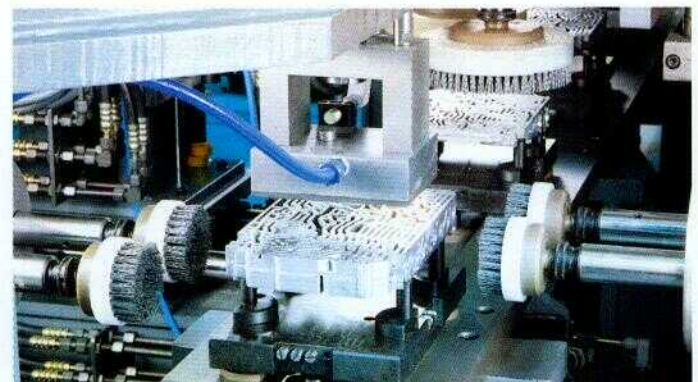

Labyrinthflächen-Entgratung durch Tellerbürsten in Rotation und Oszillation.

Labyrinthine surface deburring using circular disk brushes in rotation and oscillation.

Information on important applications

As the only tool with a flexible surface, brushes have become one of the most versatile aids for practically all sectors of industry. Using the right brush for the right job, they provide the most cost-effective solution to many production problems. This catalogue contains a

large number of applications and brush solutions. But there are also special applications on which we would be pleased to advise you, on request.

The formation of burrs, for example, is always a problem in metal-working. To maintain quality stand-

ards, deburring must be carried out reliably and economically. Brushes from KULLEN ensure that everything goes smoothly.

For further details, please contact us for a copy of our special brochures on deburring cut edges and automatic deburring.

And if you have more specific questions or you require comprehensive advice on your particular application, our technical consultants are waiting to hear from you:

Tel. +49 (0) 71 21/14 2-0.

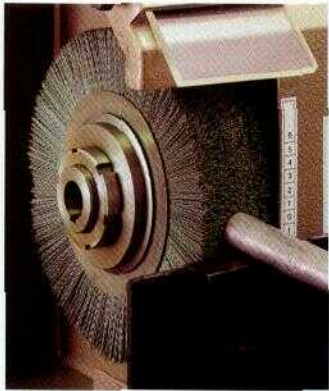

Schnittkanten-entgraten von Rohr-Abschnitten auf einer Tisch-entgratmaschine.

Deburring of the cut edges of pipe sections on bench-type deburring machines.



Konstruktionsmodell eines Bürstenkopfs mit Planetenantrieb für Spezial-Entgratmaschinen.

Design model for a brush head with planetary drive for special deburring machines.

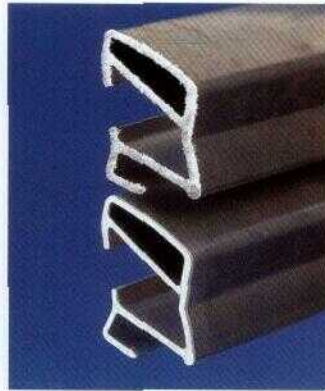

Entgraten mit Bürsten von KULLEN bringt den feinen Unterschied.

Deburring with KULLEN brushes for the difference that counts.



Entgratautomat für Rohre, Profile und Stangenmaterial von 20 - 20 000 mm Länge.

Automatic deburring machine for pipes, profile sections and bar material with lengths of 20 - 20 000 mm.

Informationen zum Gesamtprogramm

KULLEN bietet Ihnen das stärkste Lieferprogramm technischer Bürsten in Europa. Konkret bedeutet das: Über 140.000 unterschiedliche Bürstenlösungen stehen unseren Kunden heute zur Verfügung. Und täglich kommen neue hinzu, die wir gemeinsam mit Kunden aus

praktisch allen Industriezweigen realisieren. Das gilt bei **KULLEN** übrigens auch für ganz spezielle, mitunter auch ausgefallene Probleme. Daß wir dabei individuell und kundenspezifisch arbeiten, ist eine unserer Eigenarten, die uns zum Marktführer auf unserem Gebiet gemacht

haben. Eine andere ist die **Qualität von Produkten, Beratung und Service, auf die sich unsere Geschäftspartner gerne verlassen.**

Einen Überblick über unser Gesamtprogramm bietet Ihnen diese Seite. Wenn Sie mehr Informationen über unseren neuen Katalog „Bürsten-

technik“ möchten, wenden Sie sich bitte an unsere Marketing-Abteilung: **Tel. +49 (0) 71 21/142-242.**



Streifen- und Abdichtbürsten:

Zwei Beispiele aus einem breiten Programm:



Streifenbürsten an einer Staubsaugerdüse durchkämmen

und lockern so den Teppichflor oder dämpfen beim Saugen auf glatten Böden. An der Düse eines Strahl-



geräts verhindern sie, daß das Strahlgut verwirbelt.

Streifen- und Abdichtbürsten sind eben die saubere Lösung für viele Aufgaben. Diese Bürsten dichten nicht nur an Fenstern oder Türen lückenlos ab, sie schützen auch bewegte Teile in Maschinen vor Verschmutzung, führen empfindliche Teile, bremsen ab oder drücken an.

Strip and Sealing Brushes:

Two examples from a wide range of products: Strip brushes on a vacuum cleaner nozzle, comb through and lift the pile or ensure smooth gliding when vacuuming on polished floors.

On the nozzle of a sandblasting cleaner, they prevent swirling of the blasting medium.

Strip and sealing brushes are simply the best solution for a wide variety of tasks. These brushes not only provide a continuous seal for windows and doors, but also protect moving parts in machines against dirt, guide sensitive workpieces, retard or apply pressure.

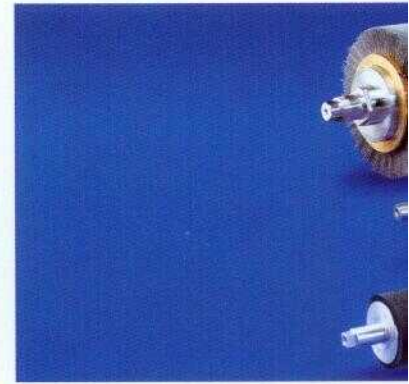

Walzenbürsten:

Bei Walzenbürsten bieten wir Ihnen die verschiedensten Konstruktionsmöglichkeiten an. Neben unserem



Optimum an Besatzdichte und gleichmäßiger Oberfläche, der Spiralwalzenbürsten, bieten wir



auch besonders wirtschaftliche und flexible Einweg-Systeme an, z.B. das

ST-System mit Trapezverzahnung. Die Anwendungsvielfalt von Walzenbürsten ist nahezu unbegrenzt: zum Reinigen, Führen, Verteilen, Befeuchten – und vieles mehr. Die abgebildete spiralförmig besetzte Walzenbürste wurde speziell für die Bearbeitung von stark profilierten Hölzern entwickelt.

Information on the full range of products

KULLEN offers you the most powerful line of technical brushes in Europe. To be more specific this means that our customers can today choose from over 140.000 different brush solutions – and this number is growing daily: Solutions which we develop in close cooperation

with customers from practically all sectors of industry. KULLEN is your ideal partner, even for very special applications and for even the most unusual of problems. That we work to meet the individual problems of all our customers is one of the traits which have made us the

market leader in our business. Another is the quality of products, advice and service on which our business partners are glad to rely.

"Brush Technology", please contact our Marketing Department:
Tel. +49 (0) 71 21/142-242.

This page gives you a general overview of our complete range of products. For further informations concerning our newest catalogue

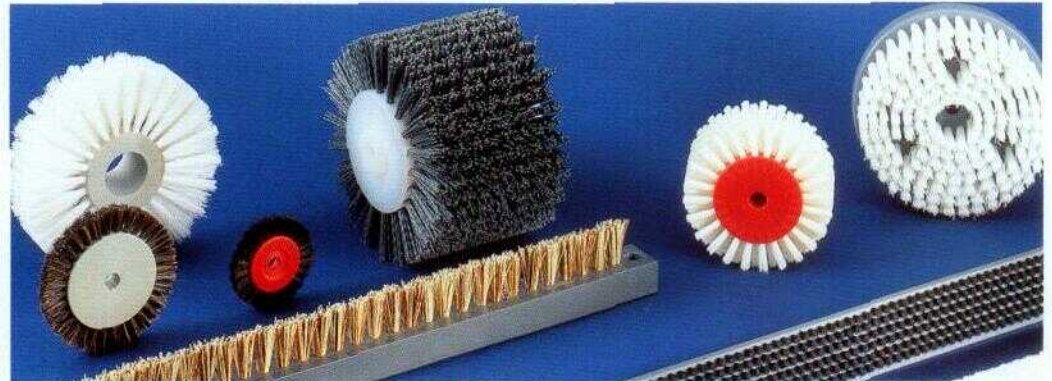

Roller Brushes:

We offer you a wide range of roller brush designs for all diverse applications. In addition to our optimum fill densities and equal surface, the spiral roller brush, we also offer extremely economical and flexible interchangeable systems, e.g. the ST System with trapezoidal teeth. The wide range of potential applications is practically unlimited: For cleaning, guiding, transporting, moistening – and much, much more. The illustrated spiral fill-roller brush was developed specially for machining heavily profiled timber.

Rund-, Teller- und Lattenbürsten:



Entsprechend den vielen unterschiedlichen Einsatzmöglichkeiten sind sie in jeder Besatzart lieferbar. Ob Naturborsten, Pflanzenborsten, Kunststoff- oder Drahtborsten.



KULLEN kann praktisch jede beliebige Körperform als Bürste bestücken. Wie hier die Zahnriemenbürste, die als Transport- und Reinigungselement eingesetzt wird oder die abgebildeten Sonderformen. Die Bürstenkörper sind aus Holz, Kunststoff oder Metall lieferbar.

Circular, Circular Disc and Lath Brushes:

To meet the requirements of their many potential applications, these special brushes are available with all kinds of fill material – natural bristles, vegetable fibres, synthetic or wire. KULLEN can transform practically any shape of corps into a brush. For example, the toothed belt brush shown here which is used as a transport and cleaning element or the special shapes illustrated. The brushes are available with bodies of wood, plastic or metal.



Änderungen, die dem technischen Fortschritt dienen, sowie Irrtum und Druckfehler vorbehalten

KULLEN GmbH & Co. KG · Postfach 2044 · D-72766 Reutlingen · Tel. +49 (0)71 21/1 42-0 · Fax +49 (0)71 21/1 42-260

Internet: <http://www.kullen.de> · E-Mail: post@kullen.de

Die Unternehmensgruppe: KULLEN, Reutlingen/D · HK-Entgrattechnik, Reutlingen/D · KULLEN CZ, Klatovy/CZ

R.I.B., Llandoverly/GB · Kleeneze Sealtech, Bristol/GB · Beilun Futuo Mechanical Tools, Ningbo/VRC

Die Welt der Bürstentechnik