

power-driven carrier rollers // up to 40 kg

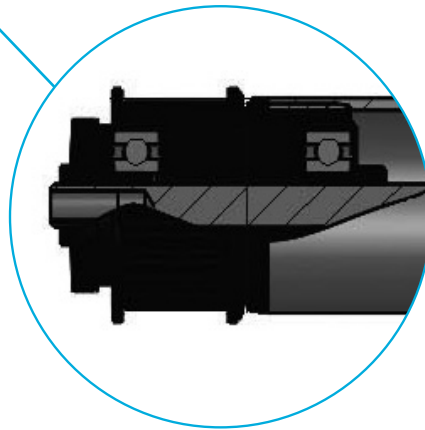
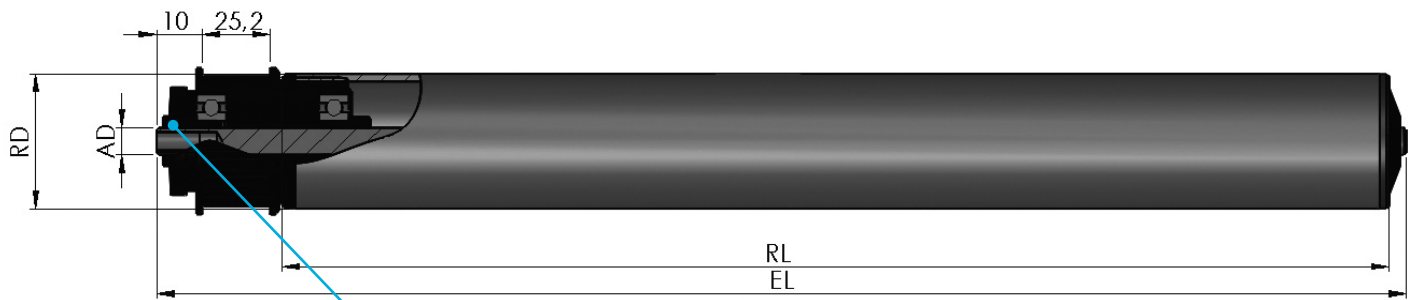

2Z-KU-fixed/accumulating

Areas of use:

- for transporting lightweight products on a power-driven roller conveyor
- for dry and dust-free environments

counter-bearing:

- the type of bearing depends on the application: select between TKL and TRK

Drive:

- toothed belt made of plastic, with 20 teeth, T8 polychain
- available as 2Z-KU-Fix: (fixed drive) or 2Z-KU-Accu: (accumulating drive)

Properties:

- minimal running noises
- faster conveying speeds
- load capacity: max. 40 kg/roller
(Depending on the load limit of tube, bearing and axle; refer to the general information)

Optional:

- variety of coatings are available
- stainless steel bearing, tube and axle

Suitable castors can be found on page 558

Combination

counter-bearing		tube-Ø	axle-Ø	ST	STI	STP	N	KB	KGH	ALU	STG
TKL	TRK										
x	x	50 x 1.5	12 / 14	x	x	x	x			x	x
x	x	50 x 2	12 / 14	x	x	x	x				x
x		50 x 2.8	12 / 14					x	x		
x	x	60 x 2	12 / 14	x	x	x					x
x		60.3 x 1.65	12 / 14				x				x
x		63 x 3	12 / 14					x	x		
x	x	63.5 x 2.9	12 / 14	x	x						x
x	x	80 x 2	12 / 14	x	x	x	x				x
x		90 x 7	12 / 14					x	x		

Axle type

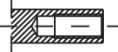
counter-bearing	axle-Ø mm	EL=	 internal thread
TKL	12	RL +	46
	14	RL +	46
TRK	12	RL +	48
	14	RL +	48

 "Other axle end finishes are possible"

Order example

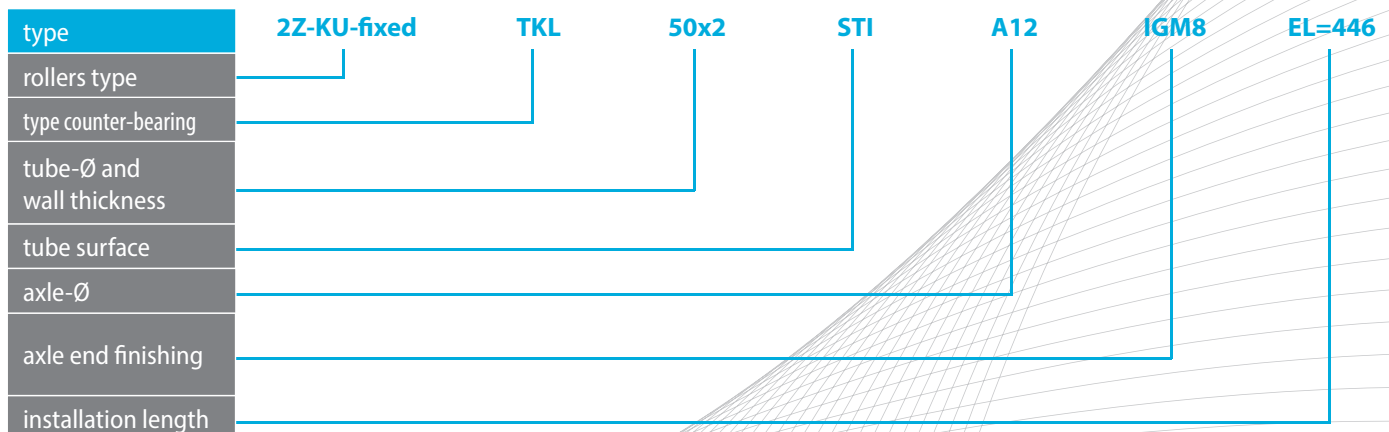

power-driven carrier rollers // up to 100 kg

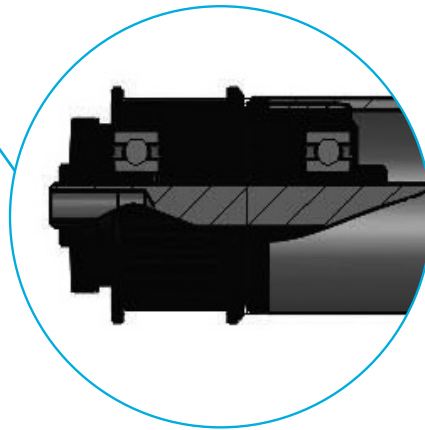
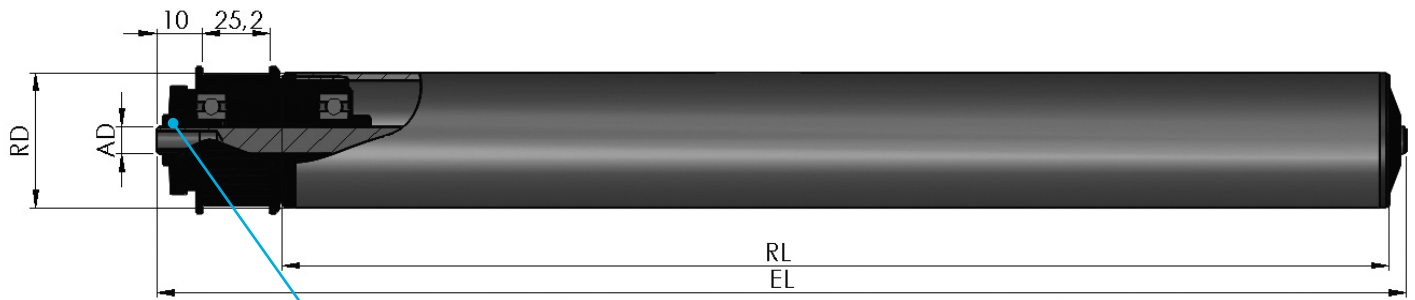

2Z-ST-fixed/accumulating

Areas of use:

- for transporting medium-weight products on a power-driven roller conveyor
- for dry and dust-free environments

counter-bearing:

- the type of bearing depends on the application:
select between TKL and TRK

Drive:

- toothed belt made of steel, with 20 teeth, T8 polychain
- available as 2Z-ST-Fix: (fixed drive) or
2Z-ST-Accu: (accumulating drive)

Properties:

- faster conveying speeds
- load capacity: max. 100 kg/roller
(Depending on the load limit of tube, bearing and axle;
refer to the general information)

Optional:

- available with various coatings
- antistatic
- stainless steel bearing, tube and axle
- for heated and cold storage applications

Suitable castors can be found on page 558

Combination

counter-bearing											
TKL	TRK	tube-Ø	axle-Ø	ST	STI	STP	N	KB	KGH	ALU	STG
x	x	50 x 1.5	12 / 14 / 15 / 17	x	x	x	x			x	x
x	x	50 x 2	12 / 14 / 15 / 17	x	x	x	x				x
x		50 x 2.8	12 / 14 / 15 / 17					x	x		
x	x	60 x 2	12 / 14 / 15 / 17	x	x	x					x
x		60.3 x 1.65	12 / 14 / 15 / 17				x				x
x		63 x 3	12 / 14 / 15 / 17					x	x		
x	x	63.5 x 2.9	12 / 14 / 15 / 17	x	x						x
x	x	80 x 2	12 / 14 / 15 / 17	x	x	x	x				x
x		90 x 7	12 / 14 / 15 / 17					x	x		

Axle type

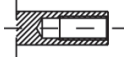
counter-bearing	axle-Ø mm	EL=	 internal thread
TKL	12	RL +	46
	14	RL +	46
	15	RL +	46
	17	RL +	46
TRK	12	RL +	48
	14	RL +	48
	15	RL +	48
	17	RL +	48

 "Other axle end finishes are possible"

Order example

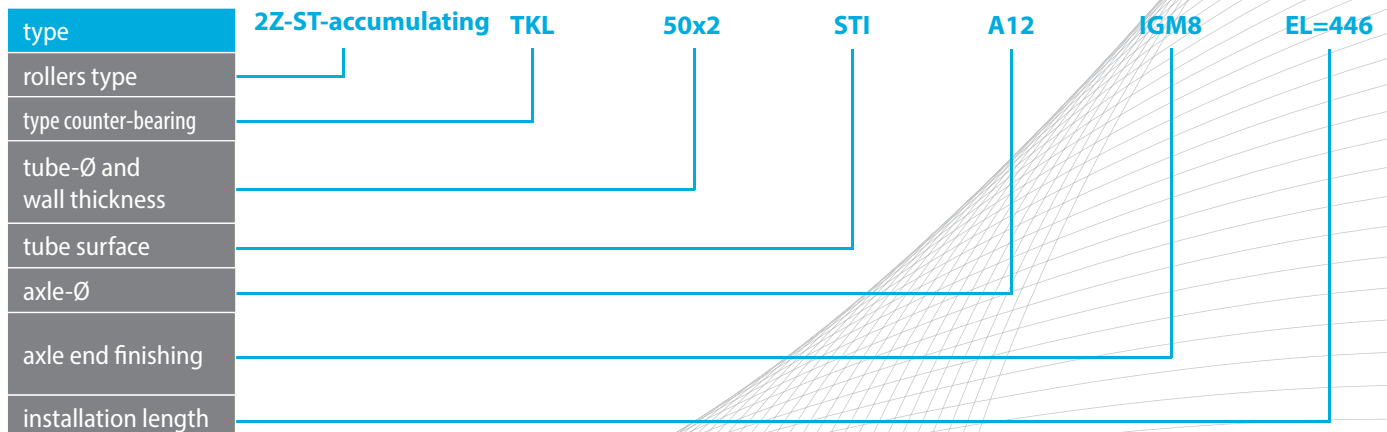

power-driven carrier rollers // up to 100 kg

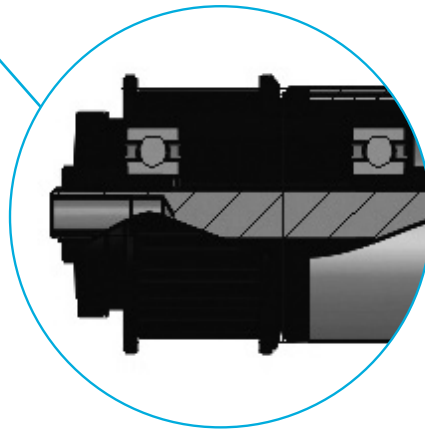
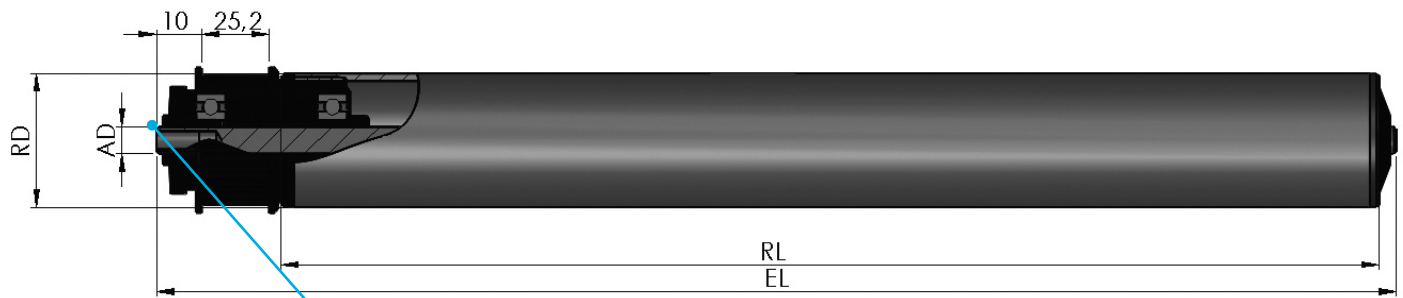

2Z-ST-welded

Areas of use:

- for transporting medium-weight products on a power-driven roller conveyor
- for dry and dust-free environments

counter-bearing:

- the type of bearing depends on the application: select between TKL and TRK

Drive:

- toothed belt made of steel, with 20 teeth, T8 polychain

Properties:

- faster conveying speeds
- load capacity: max. 100 kg/roller (Depending on the load limit of tube, bearing and axle; refer to the general information)

Optional:

- available with various coatings
- antistatic
- stainless steel bearing, tube and axle
- for heated and cold storage applications

Suitable castors can be found on page 558

Combination

counter-bearing

TKL	TRK	tube-Ø	axle-Ø	ST	STI	STP	N	KB	KGH	ALU	STG
x	x	50 x 1.5	12 / 14 / 15 / 17	x	x	x	x			x	x
x	x	50 x 2	12 / 14 / 15 / 17	x	x	x	x				x
x		50 x 2.8	12 / 14 / 15 / 17					x	x		
x	x	60 x 2	12 / 14 / 15 / 17	x	x	x					x
x		60.3 x 1.65	12 / 14 / 15 / 17				x				x
x		63 x 3	12 / 14 / 15 / 17					x	x		
x	x	63.5 x 2.9	12 / 14 / 15 / 17	x	x						x
x	x	80 x 2	12 / 14 / 15 / 17	x	x	x	x				x
x		90 x 7	12 / 14 / 15 / 17					x	x		

Axle type

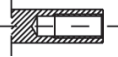
counter-bearing	axle-Ø mm	EL=	 internal thread
TKL	12	RL +	46
	14	RL +	46
	15	RL +	46
	17	RL +	46
TRK	12	RL +	48
	14	RL +	48
	15	RL +	48
	17	RL +	48

 "Other axle end finishes are possible"

Order example

type	2Z-ST-welded	TKL	50x2	STI	A12	IGM8	EL=446
rollers type							
type counter-bearing							
tube-Ø and wall thickness							
tube surface							
axle-Ø							
axle end finishing							
installation length							