

Dripless Hydraulic Multi Coupling For
Residual Pressure Connection

rtc®

COUPLING TECHNOLOGY

[www.rtc-tec.com](http://www rtc-tec.com)



M103

rtc TYPE

rtc Multicoupling systems
rtc Multikupplungssysteme type M103



rtc Multicoupling systems / rtc Multikupplungssysteme type M103



Type	Max. Working Pressure Max. Betriebsdruck	Max. Connection Pressure Max. Betriebsdruck	Flow size Nennweite	Connections Anschlüsse	Circuits Kreislauf
rtc M103.10	200 bar	20 bar	10	2 - 4 - 6 - 8	1 ↔ 1 2 ↔ 2 3 ↔ 3 4 ↔ 4

Temperature Range - Temperaturbereich
-10°C +150°C (+14° +302°F) FPM (V)



Specification

Connecting and disconnecting the circuits in one operation for quick mold change
Size Ø10
Compact design
Non spill
Code syst

Eigenschaften

Verbinden und Trennen von mehreren Kreisläufen in einem Arbeitsgang für das schnelle Rüsten
Nennweite Ø10
Robuster Verriegelungsmechanismus
Flat Face
Kodierbar

Applications

Aluminium die casting
Test units
Plastics industry / cooling heating
Core pullers

Anwendungen





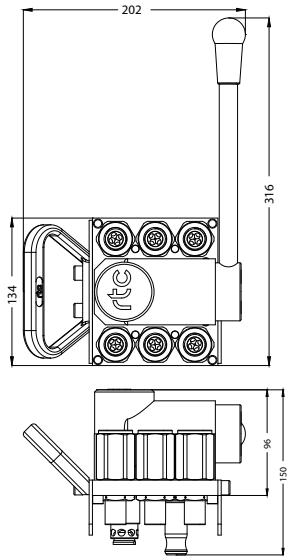
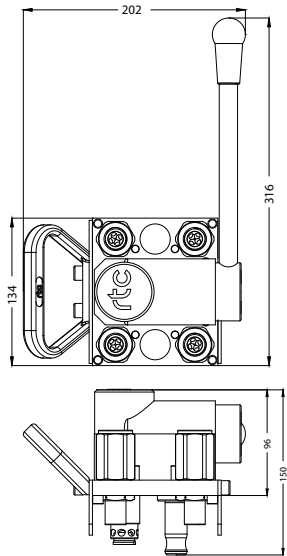
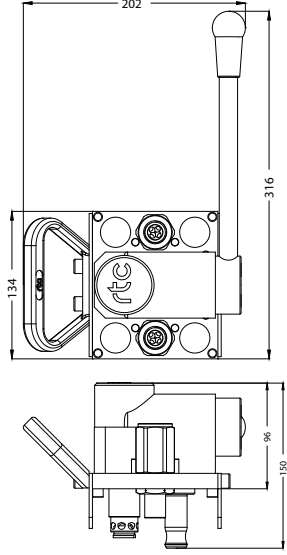

Aluminiumdruckguß
Prüfstände
Kunststoffindustrie / Mehrkreistemperierung / Kühlen Temperieren

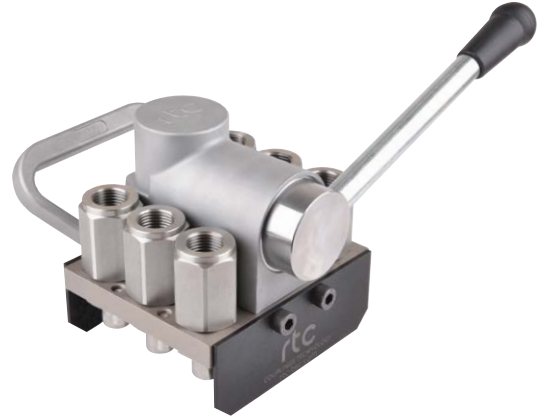

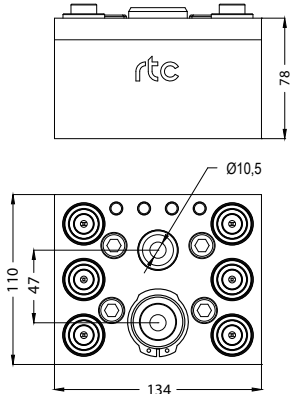

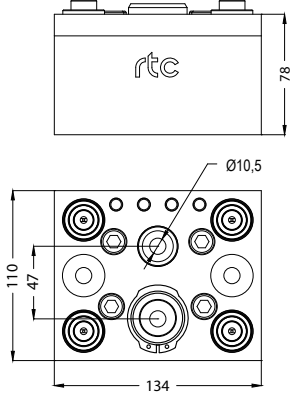

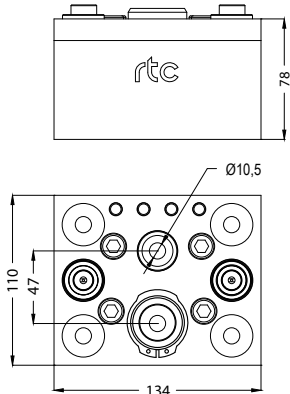
rtc TYPE M 103.10

Flow diameter 10 mm / Nennweite 10 mm

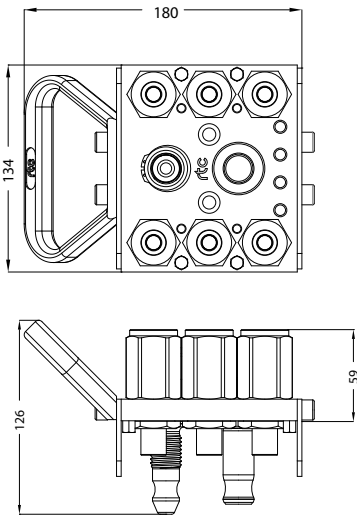
TYPE M 103.10	Mobile side with locking mechanism system / Versorgerseite mit Verriegelungsmechanismus	Item code / Artikelnummer		
<p>3 ↔ 3</p>		<p>Female thread Innengewinde</p>	<p>BSP 3/8 BSP 1/2 UNF 9/16-18 UNF 3/4-16 NPT 3/8 NPT 1/2</p>	<p>M 103.10-06 PFB 17 M 103.10-06 PFB 21 M 103.10-06 PUB 1418 M 103.10-06 PUB 1916 M 103.10-06 PNB 17 M 103.10-06 PNB 21</p>
<p>2 ↔ 2</p>		<p>Female thread Innengewinde</p>	<p>BSP 3/8 BSP 1/2 UNF 9/16-18 UNF 3/4-16 NPT 3/8 NPT 1/2</p>	<p>M 103.10-04 PFB 17 M 103.10-04 PFB 21 M 103.10-04 PUB 1418 M 103.10-04 PUB 1916 M 103.10-04 PNB 17 M 103.10-04 PNB 21</p>
<p>1 ↔ 1</p>		<p>Female thread Innengewinde</p>	<p>BSP 3/8 BSP 1/2 UNF 9/16-18 UNF 3/4-16 NPT 3/8 NPT 1/2</p>	<p>M 103.10-02 PFB 17 M 103.10-02 PFB 21 M 103.10-02 PUB 1418 M 103.10-02 PUB 1916 M 103.10-02 PNB 17 M 103.10-02 PNB 21</p>

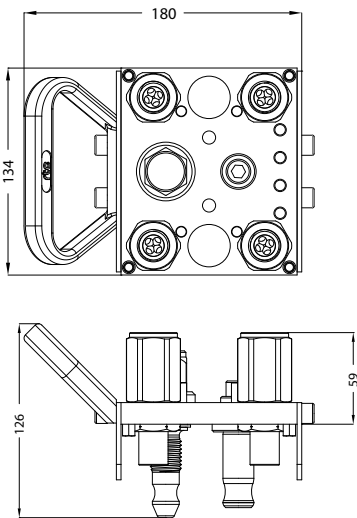

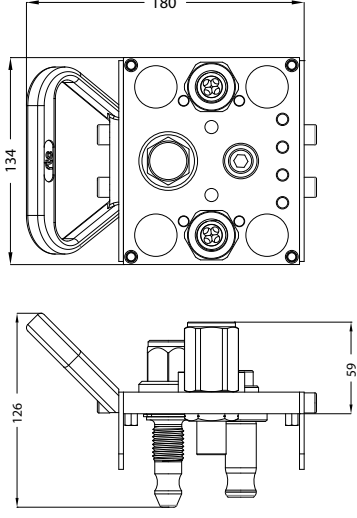



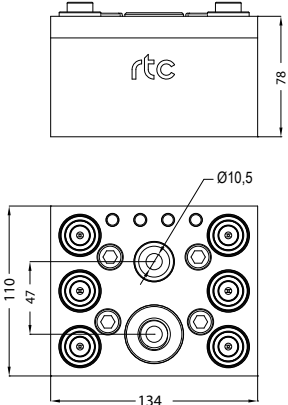

TYPE K 103.10	Mould side / Abnehmerseite		Item code / Artikelnummer	
<p>3 ↔ 3</p> 		<p>Female thread Innengewinde</p>	<p>BSP 3/8 BSP 1/2 UNF 9/16-18 UNF 3/4-16 NPT 3/8 NPT 1/2</p>	<p>K 103.10-06 SAB 17 K 103.10-06 SAB 21 K 103.10-06 SAB 1418 U K 103.10-06 SAB 1916 U K 103.10-06 SAB 17 N K 103.10-06 SAB 21 N</p> 
<p>2 ↔ 2</p> 		<p>Female thread Innengewinde</p>	<p>BSP 3/8 BSP 1/2 UNF 9/16-18 UNF 3/4-16 NPT 3/8 NPT 1/2</p>	<p>K 103.10-04 SAB 17 K 103.10-04 SAB 21 K 103.10-04 SAB 1418 U K 103.10-04 SAB 1916 U K 103.10-04 SAB 17 N K 103.10-04 SAB 21 N</p> 
<p>1 ↔ 1</p> 		<p>Female thread Innengewinde</p>	<p>BSP 3/8 BSP 1/2 UNF 9/16-18 UNF 3/4-16 NPT 3/8 NPT 1/2</p>	<p>K 103.10-02 SAB 17 K 103.10-02 SAB 21 K 103.10-02 SAB 1418 U K 103.10-02 SAB 1916 U K 103.10-02 SAB 17 N K 103.10-02 SAB 21 N</p> 

TYPE M 103.10	Mobile side with locking screw / Versorgerseite mit Spindelverschraubung		Item code / Artikelnummer
<p>3 ↔ 3</p>		<p>Female thread Innengewinde</p>	<p>BSP 3/8 BSP 1/2 UNF 9/16-18 UNF 3/4-16 NPT 3/8 NPT 1/2</p> <p>M 103.10-06 PFB 17 LP M 103.10-06 PFB 21 LP M 103.10-06 PUB 1418 LP M 103.10-06 PUB 1916 LP M 103.10-06 PNB 17 LP M 103.10-06 PNB 21 LP</p> 
<p>2 ↔ 2</p>		<p>Female thread Innengewinde</p>	<p>BSP 3/8 BSP 1/2 UNF 9/16-18 UNF 3/4-16 NPT 3/8 NPT 1/2</p> <p>M 103.10-04 PFB 17 LP M 103.10-04 PFB 21 LP M 103.10-04 PUB 1418 LP M 103.10-04 PUB 1916 LP M 103.10-04 PNB 17 LP M 103.10-04 PNB 21 LP</p> 
<p>1 ↔ 1</p>		<p>Female thread Innengewinde</p>	<p>BSP 3/8 BSP 1/2 UNF 9/16-18 UNF 3/4-16 NPT 3/8 NPT 1/2</p> <p>M 103.10-02 PFB 17 LP M 103.10-02 PFB 21 LP M 103.10-02 PUB 1418 LP M 103.10-02 PUB 1916 LP M 103.10-02 PNB 17 LP M 103.10-02 PNB 21 LP</p> 

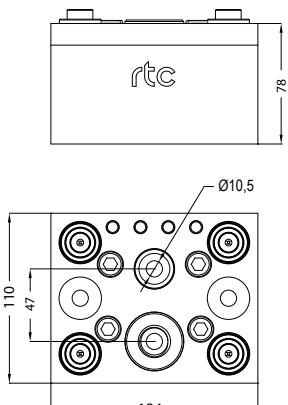
Flow diameter 10 mm / Nennweite 10 mm

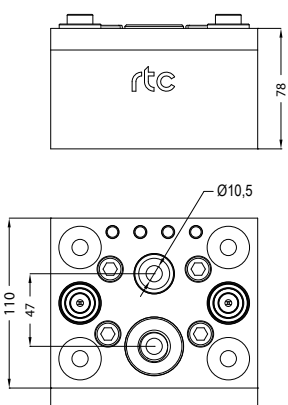
TYPE M 103.10 **rtc**

TYPE K 103.10	Mould side with locking nut / Abnehmerseite mit Schraubbuchse		Item code / Artikelnummer
<p>3 ↔ 3</p> 		<p>Female thread Innengewinde</p>	<p>BSP 3/8 BSP 1/2 UNF 9/16-18 UNF 3/4-16 NPT 3/8 NPT 1/2</p> <p>K 103.10-06 SAB 17 LN K 103.10-06 SAB 21 LN K 103.10-06 SAB 1418 U LN K 103.10-06 SAB 1916 U LN K 103.10-06 SAB 17 N LN K 103.10-06 SAB 21 N LN</p> 
<p>2 ↔ 2</p> 		<p>Female thread Innengewinde</p>	<p>BSP 3/8 BSP 1/2 UNF 9/16-18 UNF 3/4-16 NPT 3/8 NPT 1/2</p> <p>K 103.10-04 SAB 17 LN K 103.10-04 SAB 21 LN K 103.10-04 SAB 1418 U LN K 103.10-04 SAB 1916 U LN K 103.10-04 SAB 17 N LN K 103.10-04 SAB 21 N LN</p> 
<p>1 ↔ 1</p> 		<p>Female thread Innengewinde</p>	<p>BSP 3/8 BSP 1/2 UNF 9/16-18 UNF 3/4-16 NPT 3/8 NPT 1/2</p> <p>K 103.10-02 SAB 17 LN K 103.10-02 SAB 21 LN K 103.10-02 SAB 1418 U LN K 103.10-02 SAB 1916 U LN K 103.10-02 SAB 17 N LN K 103.10-02 SAB 21 N LN</p> 

rtc TYPE M 103.10

TYPE M 103	Parking plate / Parkplatte	Item code / Artikelnummer
	For mobile side Für Versorgerseiten	For M 103.10 Für M 103.10
	M 104.08-06 PP	

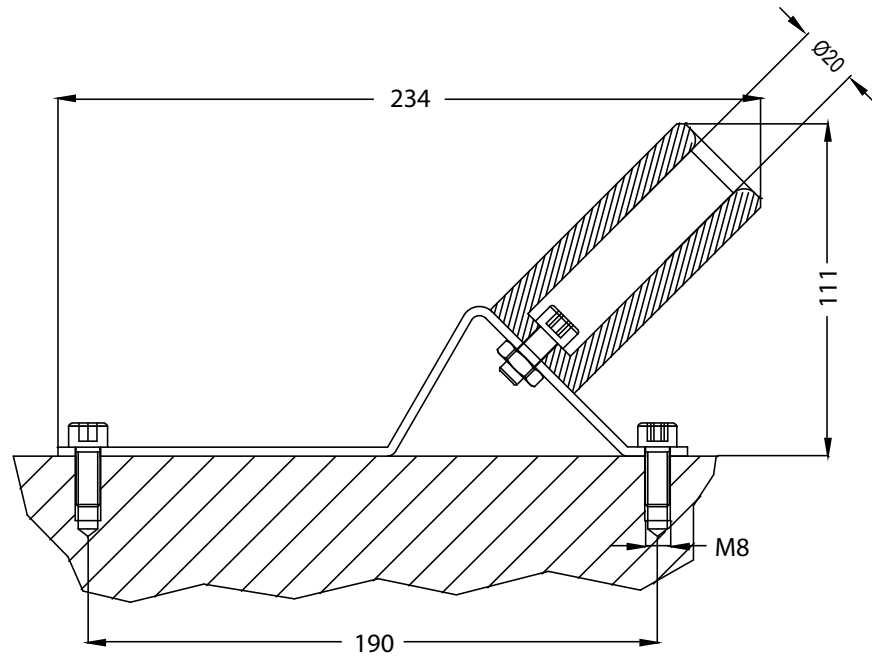

TYPE M 103	Parking plate / Parkplatte
------------	----------------------------

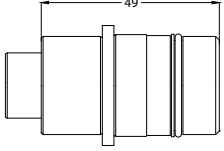

<p>TYPE M 103.10</p>	<p>Sockets / Kupplungen</p> 	<p>Assembling socket Kupplung für den Einbau</p>		<p>Ø10 mm</p>	<p>Item code / Artikelnummer 103.10 SAB 00 MP</p>
<p>TYPE M 103.10</p>		<p>Plugs / Nippel</p>	<p>Female thread Innengewinde</p>		<p>BSP 3/8 BSP 1/2 UNF 9/16-18 UNF 3/4-16 NPT 3/8 NPT 1/2</p> <p>103.10 PFB 17 MP 103.10 PFB 21 MP 103.10 PFB 1418 MP 103.10 PUB 1916 MP 103.10 PNB 17 MP 103.10 PNB 21 MP</p>
