

# HAHN DOUBLE-STROKE GAS SPRINGS



© HAHN Gasfedern GmbH 10/2013  
The catalogue is subject to technical alterations and printing mistakes.



**HAHN Gasfedern GmbH**

Waldstrasse 39–43, 73773 Aichwald, Germany  
Fon +49(0)711 936 705-0 | Fax -40  
info@hahn-gasfedern.com | www.hahn-gasfedern.com



**High-Tech made in Germany**  
www.hahn-gasfedern.com

# HAHN DOUBLE-STROKE GAS SPRINGS

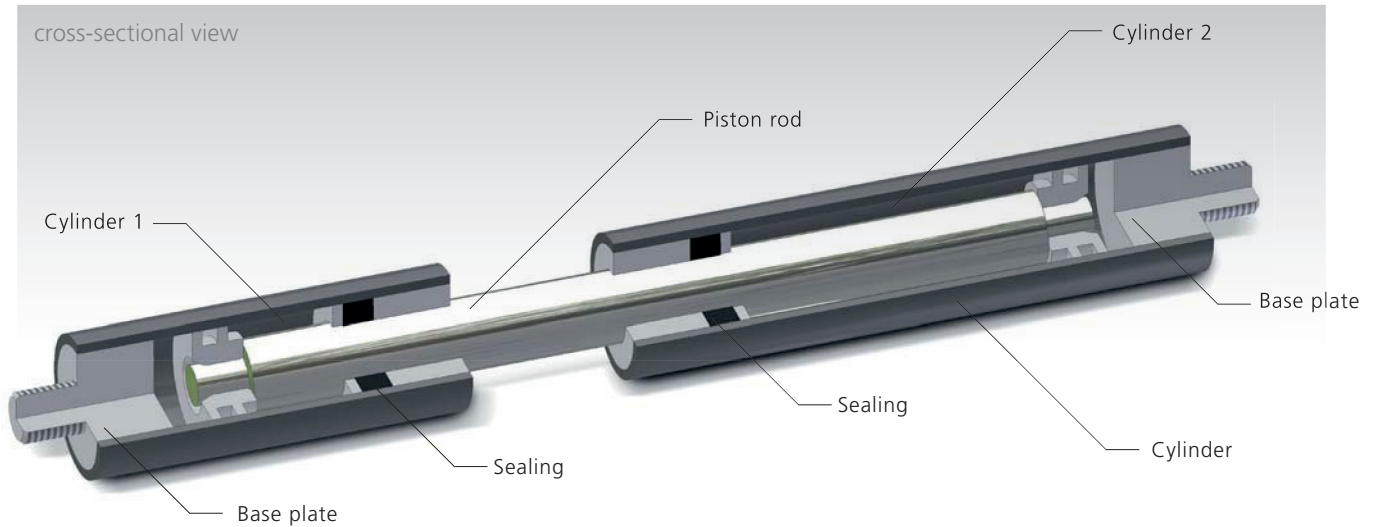

**The special strength of HAHN Gasfedern is the solution of customer-specific tasks, for which we also develop unusual springs and products. The patent-protected double-stroke spring is an example for this.**

HAHN Gasfedern developed special double-stroke springs for heavy flaps with a large opening angle, which are characterised by a low starting and a high ultimate force. These springs have two pressure cylinders that can be filled differently and thus are able to cover two force ranges. The compression of the piston rod generates a bent characteristic curve, which can be better adjusted to the force progression of the flap.

Double-stroke springs are specially designed for the application you require. The force ranges are exactly attuned to each other and adapted to the required kinematics. HAHN double-stroke springs are available in steel, in AISI 303/304 and AISI 316L/316Ti.

