

## Spare part list

STAR LIFTKET  
ELECTRIC CHAIN HOIST





**LIFTKET Hoffmann GmbH**

Dresdener Straße 64-68

04808 Wurzen / Germany

 +49-3425-89 24-0

 +49-3425-89 24-99

 [sales@liftket.de](mailto:sales@liftket.de)

 [www.liftket.de](http://www.liftket.de)

Ho 01/2018 englisch

## Overview

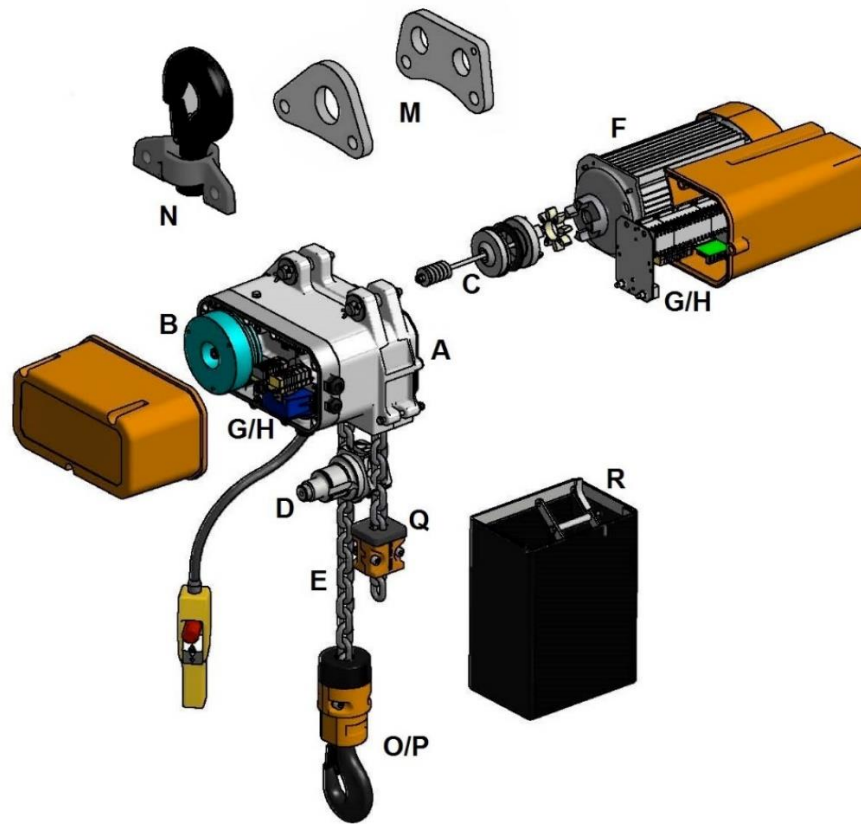

| Code                   | Description           | Page |
|------------------------|-----------------------|------|
| A                      | Hoist body            | 4    |
| B                      | Brake                 | 8    |
| C                      | Clutch                | 9    |
| D                      | Sprocket wheel        | 11   |
| E                      | Chain                 | 13   |
| F                      | Motor                 | 14   |
| G                      | Direct control        | 16   |
| H                      | Low voltage control   | 21   |
| J                      | Electric limit switch | 27   |
| M                      | Suspension eyes       | 28   |
| N                      | Hook suspension       | 29   |
| O                      | Hook block            | 30   |
| P                      | Hook tackle           | 31   |
| Q                      | Lift limiter          | 33   |
| R                      | Chain box             | 34   |
| Order form spare parts |                       | 37   |

## A – Hoist body

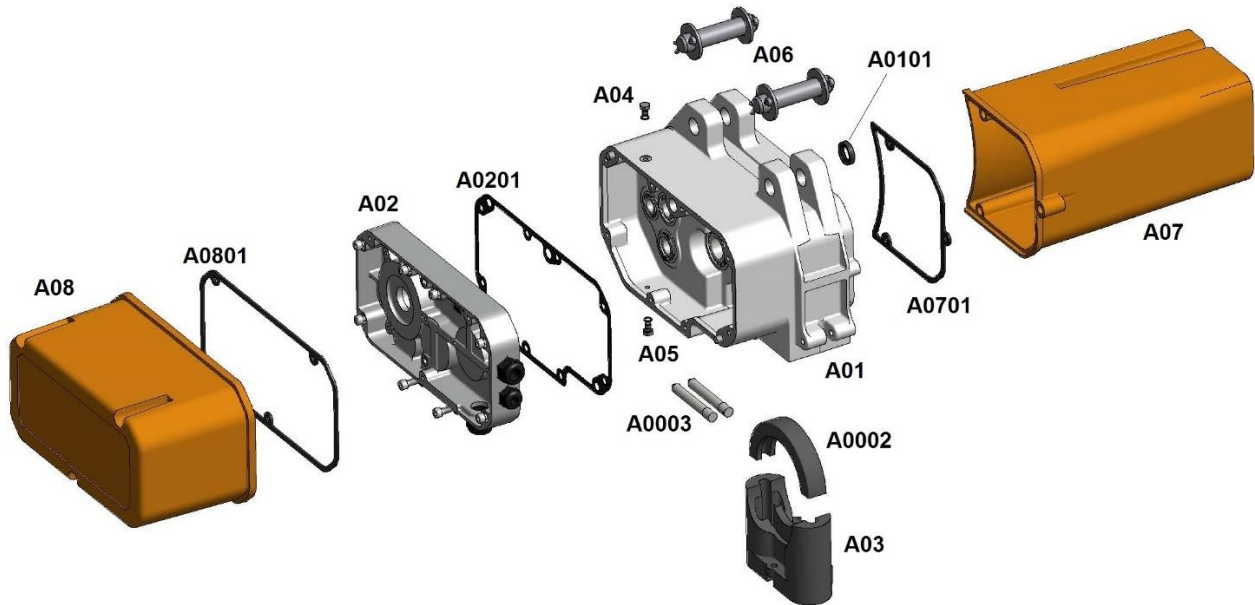

### Version STAR 02../..

| Code  | Description                        | Version                | Order number      |
|-------|------------------------------------|------------------------|-------------------|
| A01   | hoist body cpl.                    | STAR 02../..           | 03 9 020 52 001/1 |
|       |                                    | STAR 020/50            | 03 9 020 50 001/1 |
| A0101 | shaft seal                         |                        | 64 10012 02407    |
| A02   | gear cover cpl.                    | STAR 02../..           | 03 9 020 52 002/1 |
|       |                                    | STAR 020/50            | 03 9 020 50 002/1 |
| A0201 | gasket for gear cover              |                        | 03 0 020 50 035/0 |
| A03   | chain guide cpl.                   | with limit switches    | 03 9 020 50 008/1 |
|       |                                    | without limit switches | 03 8 020 50 008/0 |
| A04   | oil filling screw cpl.             |                        | 01 9 00A 200/0    |
| A05   | oil draining screw cpl.            |                        | 01 9 00A 201/0    |
| A06   | set of bolts                       |                        | 03 9 020 50 210/0 |
| A07   | cap for electric control cpl.      |                        | 03 9 020 50 005/0 |
| A0701 | gasket for cap of electric control |                        | 03 0 020 50 039/0 |
| A08   | cap for gear cover cpl.            |                        | 03 9 020 50 004/0 |
| A0801 | gasket for cap of gear cover       |                        | 03 0 020 50 036/0 |
| A0002 | hold down                          |                        | 53 S0020 02900    |
| A0003 | chain fork                         |                        | 23 S0020 00070    |

## Version STAR 03./..

| Code  | Description                        | Version                | Order number      |
|-------|------------------------------------|------------------------|-------------------|
| A01   | hoist body cpl.                    |                        | 03 9 020 52 001/1 |
| A0101 | shaft seal                         |                        | 64 10012 02407    |
| A02   | gear cover cpl.                    |                        | 03 9 020 52 002/1 |
| A0201 | gasket for gear cover              |                        | 03 0 020 50 035/0 |
| A03   | chain guide cpl.                   | with limit switches    | 03 9 030 50 008/1 |
|       | chain guide cpl.                   | without limit switches | 03 8 030 50 008/0 |
| A04   | oil filling screw cpl.             |                        | 01 9 00A 200/0    |
| A05   | oil draining screw cpl.            |                        | 01 9 00A 201/0    |
| A06   | set of bolts                       |                        | 03 9 020 50 210/0 |
| A07   | cap for electric control cpl.      |                        | 03 9 020 50 005/0 |
| A0701 | gasket for cap of electric control |                        | 03 0 020 50 039/0 |
| A08   | cap for gear cover cpl.            |                        | 03 9 020 50 004/0 |
| A0801 | gasket for cap of gear cover       |                        | 03 0 020 50 036/0 |
| A0002 | hold down                          |                        | 53 S0030 02900    |
| A0003 | chain fork                         |                        | 23 S0020 00070    |

## Version STAR 05./..

| Code  | Description                        | Version                | Order number      |
|-------|------------------------------------|------------------------|-------------------|
| A01   | hoist body cpl.                    | STAR 05./..            | 03 9 050 52 001/0 |
|       |                                    | STAR 051/52            | 03 9 051 52 001/0 |
| A0101 | shaft seal                         |                        | 64 10017 03207    |
| A02   | gear cover cpl.                    | STAR 05./..            | 03 9 050 52 002/0 |
|       |                                    | STAR 051/52            | 03 9 051 52 002/0 |
| A0201 | gasket for gear cover              |                        | 03 0 050 50 035/0 |
| A03   | chain guide cpl.                   | with limit switches    | 03 9 050 50 008/1 |
|       | chain guide cpl.                   | without limit switches | 03 8 050 50 008/0 |
| A04   | oil filling screw cpl.             |                        | 01 9 00A 200/0    |
| A05   | oil draining screw cpl.            |                        | 01 9 00A 201/0    |
| A06   | set of bolts                       |                        | 03 9 070 50 210/0 |
| A07   | cap for electric control cpl.      |                        | 03 9 050 50 005/0 |
| A0701 | gasket for cap of electric control |                        | 03 0 050 50 039/0 |
| A08   | cap for gear cover cpl.            |                        | 03 9 050 50 004/0 |
| A0801 | gasket for cap of gear cover       |                        | 03 0 050 50 036/0 |
| A0002 | hold down                          |                        | 53 S0050 02900    |
| A0003 | chain fork                         |                        | 23 S0020 00070    |

## Version STAR 07./..

| Code  | Description                        | Version                | Order number      |
|-------|------------------------------------|------------------------|-------------------|
| A01   | hoist body cpl.                    | STAR 07./..            | 03 9 070 51 001/0 |
|       |                                    | STAR 070/56            | 03 9 070 56 001/0 |
| A0101 | shaft seal                         |                        | 64 10017 03207    |
| A02   | gear cover cpl.                    |                        | 03 9 070 51 002/0 |
| A0201 | gasket for gear cover              |                        | 03 0 050 50 035/0 |
| A03   | chain guide cpl.                   | with limit switches    | 03 9 070 50 008/1 |
|       | chain guide cpl.                   | without limit switches | 03 8 070 50 008/0 |
| A04   | oil filling screw cpl.             |                        | 01 9 00A 200/0    |
| A05   | oil draining screw cpl.            |                        | 01 9 00A 201/0    |
| A06   | set of bolts                       | STAR 07./..            | 03 9 070 50 210/0 |
|       |                                    | STAR 070/56            | 03 9 070 56 210/0 |
| A07   | cap for electric control cpl.      |                        | 03 9 050 50 005/0 |
| A0701 | gasket for cap of electric control |                        | 03 0 050 50 039/0 |
| A08   | cap for gear cover cpl.            |                        | 03 9 050 50 004/0 |
| A0801 | gasket for cap of gear cover       |                        | 03 0 050 50 036/0 |
| A0002 | hold down                          |                        | 53 S0070 02900    |
| A0003 | chain fork                         |                        | 23 S0070 00070    |

## Bauform STAR 09./..

| Code  | Description                        | Version                | Order number      |
|-------|------------------------------------|------------------------|-------------------|
| A01   | hoist body cpl.                    |                        | 03 9 090 50 001/0 |
| A0101 | shaft seal                         |                        | 64 10020 03207    |
| A02   | gear cover cpl.                    |                        | 03 9 090 50 002/0 |
|       |                                    | to serial-No. 800000   | 03 9 090 50 002/1 |
| A0202 | shaft seal                         |                        | 64 10022 03507    |
| A0201 | gasket for gear cover              |                        | 03 0 090 50 035/0 |
| A03   | chain guide cpl.                   | with limit switches    | 03 9 090 50 008/1 |
|       | chain guide cpl.                   | without limit switches | 03 8 090 50 008/0 |
| A04   | oil filling screw cpl.             |                        | 01 9 00A 200/0    |
| A05   | oil draining screw cpl.            |                        | 01 9 00A 201/0    |
| A06   | set of bolts                       |                        | 03 9 090 50 210/0 |
| A07   | cap for electric control cpl.      | STAR 09./..            | 03 9 110 50 005/1 |
|       |                                    | STAR 091/57; 091/58    | 03 9 110 51 005/0 |
| A0701 | gasket for cap of electric control |                        | 03 0 090 50 039/0 |
| A08   | cap for gear cover cpl.            | STAR 09./..            | 03 9 090 50 004/1 |
|       |                                    | STAR 091/57; 091/58    | 03 9 090 20 004/1 |
| A0801 | gasket for cap of gear cover       |                        | 03 0 090 50 036/0 |
| A0002 | hold down                          |                        | 53 S0090 02900    |
| A0003 | chain fork                         |                        | 03 2 090 50 007/0 |

## Version STAR 11./..

| Code  | Description                        | Version                | Order number      |
|-------|------------------------------------|------------------------|-------------------|
| A01   | hoist body cpl.                    |                        | 03 9 110 50 001/0 |
| A0101 | shaft seal                         |                        | 64 10020 03207    |
| A02   | gear cover cpl.                    |                        | 03 9 110 50 002/0 |
|       |                                    | to serial-No. 800000   | 03 9 110 50 002/1 |
| A0202 | shaft seal                         |                        | 64 10022 03507    |
| A0201 | gasket for gear cover              |                        | 03 0 110 50 035/0 |
| A03   | chain guide cpl.                   | with limit switches    | 03 9 110 50 008/1 |
|       | chain guide cpl.                   | without limit switches | 03 8 110 50 008/0 |
| A04   | oil filling screw cpl.             |                        | 01 9 00A 200/0    |
| A05   | oil draining screw cpl.            |                        | 01 9 00A 201/0    |
| A06   | set of bolts                       |                        | 03 9 110 50 210/0 |
| A07   | cap for electric control cpl.      | STAR 110/52; 110/54    | 03 9 110 50 005/1 |
|       |                                    | STAR 111/52; 111/54    | 03 9 110 51 005/0 |
| A0701 | gasket for cap of electric control |                        | 03 0 090 50 039/0 |
| A08   | cap for gear cover cpl.            |                        | 03 9 090 50 004/1 |
| A0801 | gasket for cap of gear cover       |                        | 03 0 090 50 036/0 |
| A0002 | hold down                          |                        | 53 S0110 02900    |
| A0003 | chain fork                         |                        | 03 2 110 50 007/0 |

## B – Brake

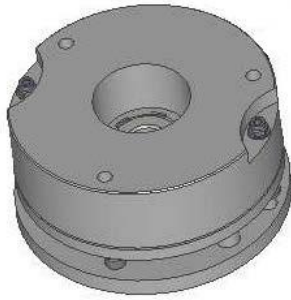

### Version STAR 02./..

| Code | Description | Version     | Order number   |
|------|-------------|-------------|----------------|
| B01  | brake cpl.  | STAR 02./.. | 17 70B06 04205 |
|      |             | STAR 020/01 | 17 70B06 04205 |

### Version STAR 03./..

| Code | Description | Version             | Order number     |
|------|-------------|---------------------|------------------|
| B01  | brake cpl.  | STAR 03./..         | 17 70B06 04205   |
|      |             | STAR 030/52; 031/52 | 17 70B06 04205MS |

### Version STAR 05./..

| Code | Description | Version             | Order number   |
|------|-------------|---------------------|----------------|
| B01  | brake cpl.  | STAR 05./..         | 17 70B08 09205 |
|      |             | STAR 051/50; 051/52 | 17 70B08 06205 |
|      |             | STAR 050/01; 050/02 | 17 70B08 06205 |

### Version STAR 07./..

| Code | Description | Version             | Order number   |
|------|-------------|---------------------|----------------|
| B01  | brake cpl.  | STAR 07./..         | 17 70B08 06205 |
|      |             | STAR 070/53; 070/56 | 17 70B08 09205 |
|      |             | STAR 070/01; 070/02 | 17 70B08 06205 |

### Version STAR 09./..

| Code | Description | Version  | Order number   |
|------|-------------|--|----------------|
| B01  | brake cpl.  | STAR 090/52; 091/51;<br>091/52                 | 17 70B10 12205 |
|      |             | STAR 090/54; 090/55;<br>091/56; 091/57; 091/58 | 17 70B12 22205 |

### Version STAR 11./..

| Code | Description | Version     | Order number   |
|------|-------------|-------------|----------------|
| B01  | brake cpl.  | STAR 11./.. | 17 70B12 22205 |



## C – Clutch

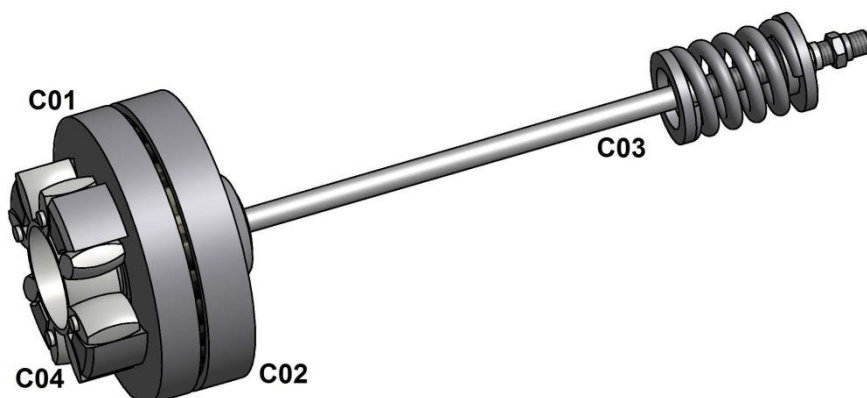

### Version STAR 02./..

| Code | Description            | Version             | Order number      |
|------|------------------------|---------------------|-------------------|
| C01  | clutch drive disc cpl. |                     | 14 2 020 50 003/1 |
| C02  | clutch disc cpl.       |                     | 14 9 020 50 005/0 |
| C03  | accessory for clutch   | STAR 02./..         | 14 9 020 50 010/0 |
|      |                        | STAR 020/52; 021/52 | 14 9 020 52 010/0 |
| C04  | gear rim               |                     | 54 00240 05502    |

### Version STAR 03./..

| Code | Description            | Version             | Order number      |
|------|------------------------|---------------------|-------------------|
| C01  | clutch drive disc cpl. |                     | 14 2 020 50 003/1 |
| C02  | clutch disc cpl.       |                     | 14 9 020 50 005/0 |
| C03  | accessory for clutch   | STAR 03./..         | 14 9 020 50 010/0 |
|      |                        | STAR 030/52; 031/52 | 14 9 030 52 010/0 |
| C04  | gear rim               |                     | 54 00240 05502    |

### Version STAR 05./..

| Code | Description            | Version | Order number      |
|------|------------------------|---------|-------------------|
| C01  | clutch drive disc cpl. |         | 14 2 050 50 003/1 |
| C02  | clutch disc cpl.       |         | 14 9 050 50 005/0 |
| C03  | accessory for clutch   |         | 14 9 050 50 010/0 |
| C04  | gear rim               |         | 54 00240 05502    |

### Version STAR 07./..

| Code | Description            | Version | Order number      |
|------|------------------------|---------|-------------------|
| C01  | clutch drive disc cpl. |         | 14 2 050 50 003/1 |
| C02  | clutch disc cpl.       |         | 14 9 050 50 005/0 |
| C03  | accessory for clutch   |         | 14 9 050 50 010/0 |
| C04  | gear rim               |         | 54 00240 05502    |

## Version STAR 09./..

| Code | Description            | Version                        | Order number      |
|------|------------------------|--------------------------------|-------------------|
| C01  | clutch drive disc cpl. |                                | 14 2 090 50 003/0 |
| C02  | clutch disc cpl.       |                                | 14 9 090 50 005/0 |
|      |                        | from serial-no. 800000         | 14 9 090 50 005/1 |
| C03  | accessory for clutch   | STAR 09./..                    | 14 9 090 50 010/0 |
|      |                        | STAR 090/52; 091/51;<br>091/52 | 14 9 090 51 010/0 |
| C04  | gear rim               |                                | 54 00380 09502    |
|      |                        | up to serial-No. D20758        | 54 00380 09502/ET |

## Version STAR 11./..

| Code | Description            | Version                 | Order number      |
|------|------------------------|-------------------------|-------------------|
| C01  | clutch drive disc cpl. |                         | 14 2 090 50 003/0 |
| C02  | clutch disc cpl.       |                         | 14 9 090 50 005/0 |
|      |                        | from serial-no. 800000  | 14 9 090 50 005/1 |
| C03  | accessory for clutch   |                         | 14 9 090 50 010/0 |
| C04  | gear rim               |                         | 54 00380 09502    |
|      |                        | up to serial-no. D20758 | 54 00380 09502/ET |

## Assembly tool

| Code | Description                   | Version             | Order number   |
|------|-------------------------------|---------------------|----------------|
| C05  | bit for tension rod of clutch | STAR 02./..; 03./.. | 91 01000 00050 |
|      |                               | STAR 05./..; 07./.. | 91 01000 00060 |
|      |                               | STAR 09./..; 11./.. | 91 01000 00080 |

## D – Sprocket wheel

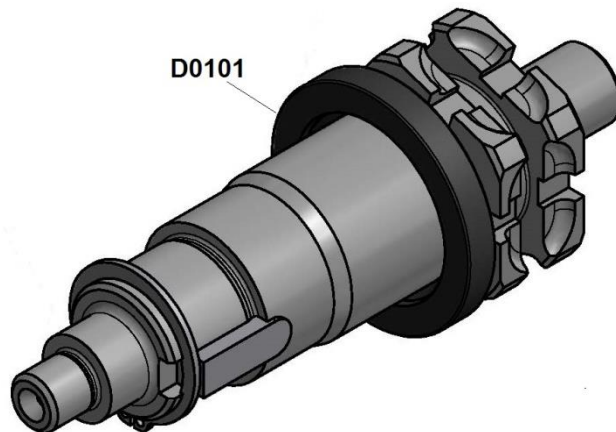

### Version STAR 02./..

| Code  | Description           | Version | Order number      |
|-------|-----------------------|---------|-------------------|
| D01   | sprocket wheel cpl.   |         | 03 9 020 50 025/0 |
| D0101 | shaft seal            |         | 64 10035 05207    |
| D0102 | shaft seal            |         | 64 10012 02407    |
| A0201 | gasket for gear cover |         | 03 0 020 50 035/0 |

### Version STAR 03./..

| Code  | Description           | Version | Order number      |
|-------|-----------------------|---------|-------------------|
| D01   | sprocket wheel cpl.   |         | 03 9 030 50 025/0 |
| D0101 | shaft seal            |         | 64 10035 05207    |
| D0102 | shaft seal            |         | 64 10012 02407    |
| A0201 | gasket for gear cover |         | 03 0 020 50 035/0 |

### Version STAR 05./..

| Code  | Description           | Version | Order number      |
|-------|-----------------------|---------|-------------------|
| D01   | sprocket wheel cpl.   |         | 03 9 050 50 025/0 |
| D0101 | shaft seal            |         | 64 10045 07510    |
| D0102 | shaft seal            |         | 64010017 03207    |
| A0201 | gasket for gear cover |         | 03 0 050 50 035/0 |

### Version STAR 07./..

| Code  | Description           | Version | Order number      |
|-------|-----------------------|---------|-------------------|
| D01   | sprocket wheel cpl.   |         | 03 9 070 50 025/0 |
| D0101 | shaft seal            |         | 64 10045 07510    |
| D0102 | shaft seal            |         | 64 10017 03207    |
| A0201 | gasket for gear cover |         | 03 0 050 50 035/0 |

## Version STAR 09./..

| Code   | Description           | Version               | Order number      |
|--------|-----------------------|-----------------------|-------------------|
| D01    | sprocket wheel cpl.   |                       | 03 9 090 50 025/0 |
|        |                       | from serial-no.800000 | 03 9 090 50 025/1 |
| D0101  | shaft seal            |                       | 64 10065 10010    |
| D0102  | shaft seal            |                       | 64 10020 03207    |
|        |                       | from serial-no.800000 | 64 10022 03507    |
| D01001 | dense disc            |                       | 96 NJ000 00205NI  |
| A0201  | gasket for gear cover |                       | 03 0 090 50 035/0 |

## Version STAR 11./..

| Code   | Description           | Version               | Order number      |
|--------|-----------------------|-----------------------|-------------------|
| D01    | sprocket wheel cpl.   |                       | 03 9 110 50 025/0 |
|        |                       | from serial-no.800000 | 03 9 110 50 025/1 |
| D0101  | shaft seal            |                       | 64 10085 12010    |
| D0102  | shaft seal            |                       | 64 10020 03207    |
|        |                       | from serial-no.800000 | 64 10022 03507    |
| D01001 | dense disc            |                       | 96 NI000 00206NI  |
| A0201  | gasket for gear cover |                       | 03 0 110 50 035/0 |

## E – Chain



### Version STAR 02./..

| Code | Description | Version | Order number    |
|------|-------------|---------|-----------------|
| E01  | chain       | 4x12 mm | 47 04012 00002V |

### Version STAR 03./..; STAR 05./..

| Code | Description | Version   | Order number    |
|------|-------------|-----------|-----------------|
| E01  | chain       | 5,2x15 mm | 47 05215 00002V |

### Version STAR 07./..

| Code | Description | Version   | Order number    |
|------|-------------|-----------|-----------------|
| E01  | chain       | 7,2x21 mm | 47 07221 00002V |

### Version STAR 09./..

| Code | Description | Version | Order number    |
|------|-------------|---------|-----------------|
| E01  | chain       | 9x27 mm | 47 09027 00002V |

### Version STAR 11./..

| Code | Description | Version    | Order number    |
|------|-------------|------------|-----------------|
| E01  | chain       | 11,3x31 mm | 47 11331 00005V |

## F – Motor

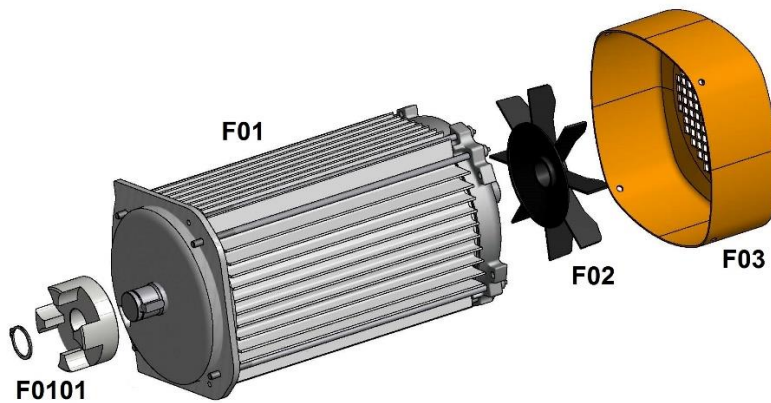

| LIFTKET   |                                   |                                 |               |
|---|-----------------------------------|---------------------------------|---------------|
| LIFTKET Hoffmann GmbH<br>www.liftket.de<br>ELEKTROKETTENZUG / ELECTRIC CHAIN HOIST<br>Made in Germany |                                   |                                 |               |
| Typ / Type<br>050/95  | Fabrik-Nr. / Serial no.<br>H35453 | Baujahr / Fabr. year<br>07/2017 |               |
| S.W.L. (kg)<br>500  | 1/1                               | 5.2x15 mm                       | EN 818-7      |
| (m/min)<br>18,0   |                                   | FEM/ISO                         | 1Bm/M3        |
|   |                                   | 60% ED                          | 240 S/h       |
| KLOR 80G2   | 690 V;                            | 50 Hz;                          | 3 ph F; IP 55 |
| 1,5 kW  |                                   | cos φ 0,90                      |               |
| 1,66 A  |                                   | 2850 min <sup>-1</sup>          |               |



### Version STAR 02./..

| Code  | Description   | According type label   | Order number  |
|-------|---|------------------------|---|
| F01   | Motor cpl. 400V, 50Hz, 3ph<br>(other voltages on request) | 63K2<br>63G2<br>63G8/2 | 42 9 063K20 000/0<br>42 9 063G20 000/0<br>42 9 063G82 000/0 |
| F01   | Motor cpl. 230V, 1ph~                                     | 63G2                   | 42 9 063G20E 000/0  |
| F0101 | clutch hub cpl.   |                        | 14 9 020 50 001/0   |
| F02   | fan impeller  |                        | 53 S0055 00560  |
| F03   | fan cap for motor   |                        | 42 9 063K40 011/0   |

### Version STAR 03./..

| Code  | Description   | According type label | Order number                           |
|-------|---|----------------------|--|
| F01   | Motor cpl. 400V, 50Hz, 3ph<br>(other voltages on request) | 63G2<br>63G8/2       | 42 9 063G20 000/0<br>42 9 063G82 000/0 |
| F0101 | clutch hub cpl.   |                      | 14 9 020 50 001/0                      |
| F02   | fan impeller  |                      | 53 S0055 00560                         |
| F03   | fan cap for motor   |                      | 42 9 063K40 011/0                      |

## Version STAR 05./..

| Code  | Description   | Accordinging type label | Order number       |
|-------|---|-------------------------|--------------------|
| F01   | Motor cpl. 400V, 50Hz, 3ph<br>(other voltages on request) | 71G2                    | 42 9 071G20 000/0  |
|       |   | 71G4                    | 42 9 071G40 000/0  |
|       |   | 71G8/2                  | 42 9 071G82 000/0  |
|       |   | 80G8/2                  | 42 9 080G82 000/0  |
| F01   | Motor cpl. 230V, 1ph~                                     | 71G2                    | 42 9 071G20E 000/0 |
| F0101 | clutch hub cpl.   |                         | 14 9 050 50 001/0  |
| F02   | fan impeller  |                         | 53 S0055 00780     |
| F03   | fan cap for motor   |                         | 42 9 071G40 011/0  |

## Version STAR 07./..

| Code  | Description   | Accordinging type label | Order number       |
|-------|---|-------------------------|--------------------|
| F01   | Motor cpl. 400V, 50Hz, 3ph<br>(other voltages on request) | 71G2                    | 42 9 071G20 000/0  |
|       |   | 80G2                    | 42 9 080G20 000/0  |
|       |   | 80G8/2                  | 42 9 080G82 000/0  |
|       | Motor cpl. 230V, 1ph~                                     | 80G2                    | 42 9 080G20E 000/0 |
| F0101 | clutch hub cpl.   |                         | 14 9 050 50 001/0  |
| F02   | fan impeller  |                         | 53 S0055 00780     |
| F03   | fan cap for motor   |                         | 42 9 071G40 011/0  |

## Version STAR 09./..

| Code  | Description   | Accordinging type label | Order number      |
|-------|---|-------------------------|-------------------|
| F01   | Motor cpl. 400V, 50Hz, 3ph<br>(other voltages on request) | 90L2                    | 42 9 090L20 000/0 |
|       |   | 90L4                    | 42 9 090L40 000/0 |
|       |   | 90L8/2                  | 42 9 090L82 000/0 |
|       |   | 100L8/2                 | 42 9 100L82 000/0 |
|       |   | 100LV8/2                | 42 9 100V82 000/0 |
| F0101 | clutch hub cpl.   |                         | 14 9 090 50 001/0 |
| F0102 | fan impeller  | 90L2, 90L4, 90L8/2      | 53 S0055 00900    |
|       |   | 100L8/2, 100LV8/2       | 53 S0055 01000    |
| F0103 | fan cap for motor   | 90L2, 90L4, 90L8/2      | 42 9 090L20 011/0 |
|       |   | 100L8/2, 100LV8/2       | 42 9 100V82 011/0 |

## Version STAR 11./..

| Code  | Description   | Accordinging type label | Order number      |
|-------|---|-------------------------|-------------------|
| F01   | Motor cpl. 400V, 50Hz, 3ph<br>(other voltages on request) | 100S2                   | 42 9 100S20 000/0 |
|       |   | 100LV8/2                | 42 9 100V82 000/0 |
| F0101 | clutch hub cpl.   |                         | 14 9 090 50 001/0 |
| F0102 | fan impeller  |                         | 53 S0055 01000    |
| F0103 | fan cap for motor   |                         | 42 9 100V82 011/0 |

## Assembly tool

| Code  | Description         | Order number   |
|-------|---------------------|----------------|
| F0104 | bit for tension rod | 91 01000 00060 |

## G – Direct control

### Direct control 400 V, 3 ph complete

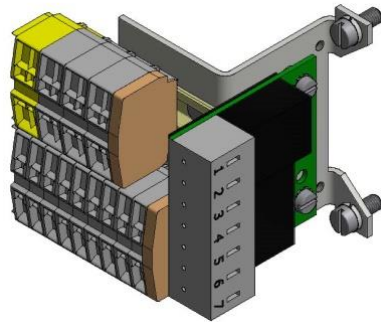

| Code | Description         | Version           | Order number      |
|------|---------------------|-------------------|-------------------|
| G01  | direct control cpl. | one lifting speed | 10 9 020 50 000/1 |

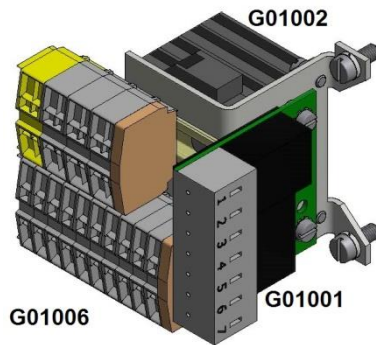

| Code | Description         | Version            | Order number      |
|------|---------------------|--------------------|-------------------|
| G01  | direct control cpl. | two lifting speeds | 10 9 021 50 000/0 |

### Direct control 230 V, 1 ph complete

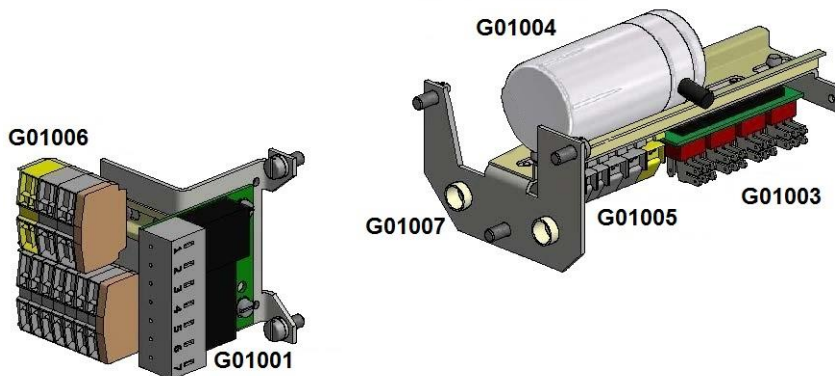



















































| Code | Description         | Version      | Order number      |
|------|---------------------|--------------|-------------------|
| G01  | direct control cpl. | STAR 020/0.. | 10 9 020 02 000/0 |
|      |                     | STAR 050/0.. | 10 9 050 01 000/0 |
|      |                     | STAR 070/0.. | 10 9 070 01 000/0 |



## Components

| Code   | Description                      | Version              | Order number      |
|--------|----------------------------------|----------------------|-------------------|
| G01001 | rectifier                        |                      | 20 00040 00040F   |
| G01002 | contactor relay for brake        |                      | 74 3LC1S K0624    |
|        | current contactor                | Type 1 – 115 turns   | 11 0 10D LC1/0    |
|        |                                  | Type 2 – 455 turns   | 11 0 10A LC1/0    |
|        |                                  | Type 3 – 66 turns    | 11 0 090 15 LC1/0 |
|        |                                  | Type 4 – 197 turns   | 11 0 050 00 LC1/0 |
| G01003 | electronic starter 230V, 1ph~    |                      | 74 40060 02220    |
| G01004 | capacitor 230V, 1ph~             | STAR 020/01          | 20 00100 00041    |
|        |                                  | STAR 050/01          | 20 00100 00060    |
|        |                                  | STAR 070/01          | 20 00100 00125    |
| G01005 | set terminal blocks (motor side) |                      | 11 9 020 50 500/0 |
| G01006 | set terminal blocks (brake side) | STAR 020/..          | 11 9 020 01 500/0 |
|        |                                  | STAR 050/.. - 111/.. | 11 9 050 50 500/0 |
| G01007 | cover plugs                      |                      | 53 SA000 00203    |

## Control pendant complete

| Code | Description     | Symbol / Function   |                |
|------|-----------------|---|----------------|
| G02  | control pendant |     | 81 B0100 00000 |
|      |                 |      | 81 B0100 000NH |
|      |                 |   for 1ph hoist   | 81 B0100 AK000 |
|      |                 |   for 1ph hoist   | 81 B0100 AK0NH |
|      |                 |       | 81 B0101 00000 |
|      |                 |                | 81 B0101 000NH |
|      |                 |       | 81 B0102 00000 |
|      |                 |           | 81 B0102 000NH |
|      |                 |     | 81 B0200 00000 |
|      |                 |      | 81 B0200 000NH |
|      |                 |       | 81 B0201 00000 |
|      |                 |      | 81 B0201 000NH |
|      |                 |       | 81 B0202 00000 |
|      |                 |      | 81 B0202 000NH |

## Control pendant / components

| Code  | Description                                     |   | Symbol / Function   | Order number   |
|-------|---|---|---|----------------|
| G0202 | contactor blocks                                |    | <br>to 3.0 kW     | 81 XES0D 02201 |
|       |   |    | <br>for 1ph hoist | 81 XES0D 02241 |
|       |   |    | <br>to 2,0 kW     | 81 XES0D 01191 |
|       |   |    | <br>to 2,2 kW     | 81 XES0D 01291 |
| G0203 | emergency stop button                           |    |                   | 81 XAC0S 00499 |
|       |   |    |   | 81 ZA2BS 00054 |
| G0204 | rubber spare parts for button one-step function |   | white   | 81 XAC0B 09111 |
|       |   |  | black   | 81 XAC0B 09112 |
|       | rubber spare parts for button two-step function |  | white   | 81 XAC0B 09211 |
|       |   |  | black   | 81 XAC0B 09212 |
|       |   |  |   |                |

## Control pendant / control cable

| Code  | Description   | Symbol / Function   | Version | Order number   |
|-------|---------------|---|---------|----------------|
| G0201 | control cable |     | 7x1,5   | 45 0YMH0 07015 |
|       |               |      | 7x1,5   | 45 0YMH0 07015 |
|       |               |       | 8x1,5   | 45 0YMH0 08015 |
|       |               |                | 8x1,5   | 45 0YMH0 08015 |
|       |               |       | 12x1,5  | 45 0YMH0 12015 |
|       |               |                | 12x1,5  | 45 0YMH0 12015 |
|       |               |     | 7x1,5   | 45 0YMH0 07015 |
|       |               |      | 7x1,5   | 45 0YMH0 07015 |
|       |               |       | 10x1,5  | 45 0YMH0 10015 |
|       |               |      | 10x1,5  | 45 0YMH0 10015 |
|       |               |       | 12x1,5  | 45 0YMH0 12015 |
|       |               |      | 12x1,5  | 45 0YMH0 12015 |

## H – Low voltage control

Low voltage control 400 V / 24 V complete

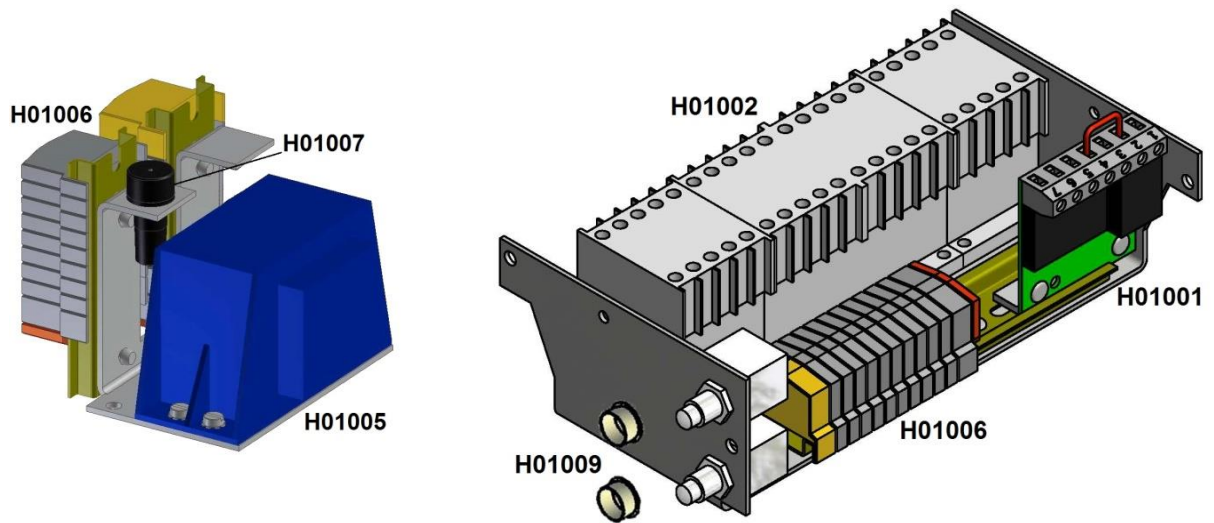

| Code  | Lifting speed |     | Emergency stop |         | Limit switch |         |
|-------|---------------|-----|----------------|---------|--------------|---------|
|       | one           | two | with           | without | with         | without |
| H0101 | x             |     | x              |         |              | x       |
| H0102 | x             |     | x              |         | x            |         |
| H0103 | x             |     |                | x       |              | x       |
| H0104 | x             |     |                | x       | x            |         |
| H0105 |               | x   | x              |         |              | x       |
| H0106 |               | x   | x              |         | x            |         |
| H0107 |               | x   |                | x       |              | x       |
| H0108 |               | x   |                | x       | x            |         |

| Code  | STAR 02../., 03../. | STAR 05../.         | STAR 07../.         |
|-------|---------------------|---------------------|---------------------|
| H0101 | 11 2 020 011N 00/4  | 11 2 050 011N 00/4  | 11 2 070 011N 00/4  |
| H0102 | 11 2 020 011NE 00/4 | 11 2 050 011NE 00/4 | 11 2 070 011NE 00/4 |
| H0103 | 11 2 020 011 00/4   | 11 2 050 011 00/4   | 11 2 070 011 00/4   |
| H0104 | 11 2 020 011 E 00/4 | 11 2 050 011 E 00/4 | 11 2 070 011 E 00/4 |
| H0105 | 11 2 021 011N 00/4  | 11 2 051 011N 00/4  | 11 2 071 011N 00/4  |
| H0106 | 11 2 021 011NE 00/4 | 11 2 051 011NE 00/4 | 11 2 071 011NE 00/4 |
| H0107 | 11 2 021 011 00/4   | 11 2 051 011 00/4   | 11 2 071 011 00/4   |
| H0108 | 11 2 021 011 E 00/4 | 11 2 051 011 E 00/4 | 11 2 071 011 E 00/4 |

| Code  | STAR 09../.         | STAR 11../.         |
|-------|---------------------|---------------------|
| H0101 | 11 2 090 011N 00/4  | 11 2 110 011N 00/4  |
| H0102 | 11 2 090 011NE 00/4 | 11 2 110 011NE 00/4 |
| H0103 | 11 2 090 011 00/4   | 11 2 110 011 00/4   |
| H0104 | 11 2 090 011 E 00/4 | 11 2 110 011 E 00/4 |
| H0105 | 11 2 091 011N 00/4  | 11 2 111 011N 00/4  |
| H0106 | 11 2 091 011NE 00/4 | 11 2 111 011NE 00/4 |
| H0107 | 11 2 091 011 00/4   | 11 2 111 011 00/4   |
| H0108 | 11 2 091 011 E 00/4 | 11 2 111 011 E 00/4 |

## Low voltage control 230 V / 24 V complete

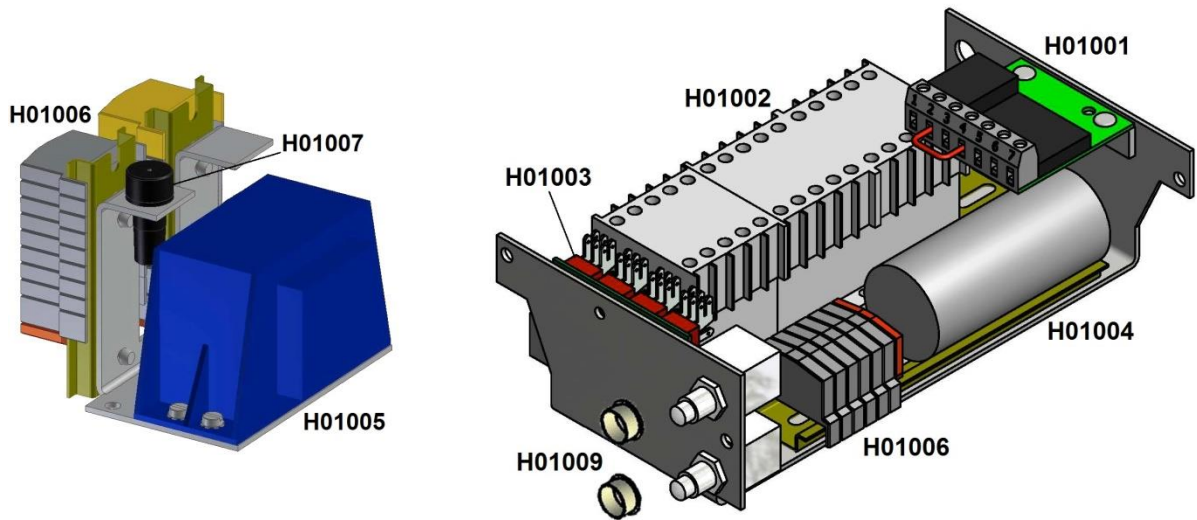















































| Code  | Emergency stop |         | Limit switch |         |
|-------|----------------|---------|--------------|---------|
|       | with           | without | with         | without |
| H0109 | x              |         |              | x       |
| H0110 | x              |         | x            |         |
| H0111 |                | x       |              | x       |
| H0112 |                | x       | x            |         |

| Code  | STAR 02../..        | STAR 05../..        | STAR 07../..        |
|-------|---------------------|---------------------|---------------------|
| H0109 | 11 2 020 101N 00/1  | 11 2 050 101N 00/1  | 11 2 070 101N 00/1  |
| H0110 | 11 2 020 101NE 00/1 | 11 2 050 101NE 00/1 | 11 2 070 101NE 00/1 |
| H0111 | 11 2 020 101 00/1   | 11 2 050 101 00/1   | 11 2 070 101 00/1   |
| H0112 | 11 2 020 101 E 00/1 | 11 2 050 101 E 00/1 | 11 2 070 101 E 00/1 |

## Components









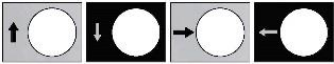

| Code   | Description                      | Version                                       | Order number   |
|--------|----------------------------------|---|--|
| H01001 | rectifier                        |   | 20 00040 00040F  |
| H01002 | contactor K1,                    | STAR 020/.., 021/..;<br>STAR 030/.., 031/..   | 74 3DSL3 01024UL <b>to 02/16</b>                                     |
|        |                                  | STAR 020/.., 021/..;<br>STAR 030/.., 031/..   | 74 3B005 10024 <b>from 03/16</b>                                     |
|        |                                  | STAR 050/.. - 110/..,<br>STAR 051/.. - 111/.. | 74 3LC1K 91024   |
|        | contactor K2, K3                 | STAR 020/.., 021/..;<br>STAR 030/.., 031/..   | 74 3DSL3 10024 <b>to 02/16</b>                                       |
|        |                                  | STAR 020/.., 021/..;<br>STAR 030/.., 031/..   | 74 3BW05 10024 <b>from 03/16</b>                                     |
|        |                                  | STAR 050/.. - 110/..,<br>STAR 051/.. - 111/.. | 74 3LC2K 91024   |
|        | contactor K4                     | STAR 021/.., 031/..                           | 74 3DSL3 22024UL <b>to 02/16</b><br>74 3B005 22024 <b>from 03/16</b> |
|        |                                  | STAR 051/.., 071/..,<br>091/.., 111/..        | 74 3LC1K 98024   |
| H01003 | electronic starter 230V,<br>1ph~ | STAR 020/0.. -<br>STAR 070/0..                | 74 40060 02220   |
| H01004 | capacitor                        | STAR 020/0..<br>STAR 050/0..<br>STAR 070/0..  | 20 00100 00041<br>20 00100 00060<br>20 00100 00125                   |
| H01005 | transformer<br>230-400V/24V      | STAR 020/.., 021/..;<br>STAR 030/.., 031/..   | 88 00400 UI024   |
|        |                                  | STAR 050/.. - 110/..,<br>STAR 051/.. - 111/.. | 88 00400 EI024   |
| H01006 | Set terminal blocks              | STAR 020/.., 021/..;<br>STAR 030/.., 031/..   | 11 9 020 50 500/0  |
|        |                                  | STAR 050/.. - 110/..,<br>STAR 051/.. - 111/.. | 11 9 050 50 500/0  |
| H01007 | fuse holder                      | primary                                       | 20 00060 00080   |
|        |                                  | secondary                                     | 20 00060 00086   |
| H01008 | fuse                             | 1,25 A  | 20 00060 00082   |
| H01009 | cover plugs                      |   | 53 SA000 00202   |

## Control pendant complete













| Code | Description     | Symbol / Function   | Order number   |
|------|-----------------|---|----------------|
| H02  | control pendant |     | 81 A0100 00000 |
|      |                 |      | 81 A0100 000NH |
|      |                 |       | 81 A0101 00000 |
|      |                 |                | 81 A0101 000NH |
|      |                 |       | 81 A0102 00000 |
|      |                 |                | 81 A0102 000NH |
|      |                 |     | 81 A0200 00000 |
|      |                 |      | 81 A0200 000NH |
|      |                 |       | 81 A0201 00000 |
|      |                 |      | 81 A0201 000NH |
|      |                 |       | 81 A0202 00000 |
|      |                 |      | 81 A0202 000NH |



## Control pendant / Components

| Code  | Description                    |   | Symbol / Function  | Order number   |
|-------|--------------------------------|---|--|----------------|
| H0202 | contactor blocks               |  |  | 81 ZB2BE 00101 |
|       |                                |  |  | 81 ZB2BE 00201 |
|       |                                |  |  | 81 XEN0G 01191 |
|       |                                |  |   | 81 ZB2BE 00102 |
|       |                                |   |  | 81 ZA2BS 00834 |
| H0203 | emergency stop button          |  |  |                |
| H0204 | rubber spare parts for buttons |  | white  | 81 XAC0A 09411 |
|       |                                |  | black  | 81 XAC0A 09412 |

## Control pendant / control cable

| Code  | Description   | Symbol / Function   | Version | Order number   |
|-------|---------------|---|---------|----------------|
| H0201 | control cable |     | 4G1,5   | 45 0H070 04G15 |
|       |               |      | 5G1,5   | 45 0H070 05G15 |
|       |               |       | 7G1,5   | 45 0YMH0 07G15 |
|       |               |                | 7G1,5   | 45 0YMH0 07G15 |
|       |               |       | 7G1,5   | 45 0YMH0 07G15 |
|       |               |                | 12G1,5  | 45 0H070 12G15 |
|       |               |     | 5G1,5   | 45 0H070 05G15 |
|       |               |      | 7G1,5   | 45 0YMH0 07G15 |
|       |               |       | 7G1,5   | 45 0YMH0 07G15 |
|       |               |      | 12G1,5  | 45 0H070 12G15 |
|       |               |       | 12G1,5  | 45 0H070 12G15 |
|       |               |      | 12G1,5  | 45 0H070 12G15 |

## J – Electric limit switches

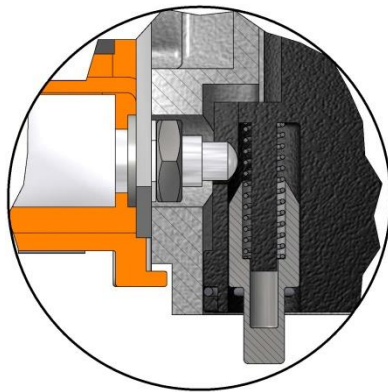
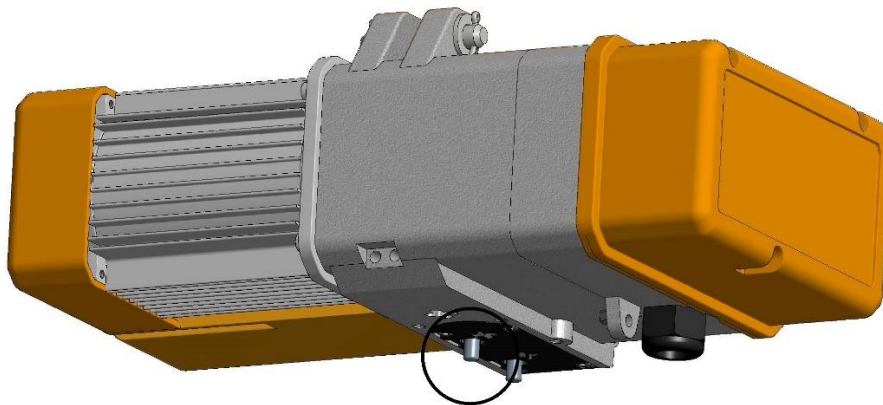

**J01**



**J02**

| Code       | Description                | Version             | Order number      |
|------------|----------------------------|---------------------|-------------------|
| <b>J01</b> | electric limit switch cpl. |                     | 46 9 020 50 217/0 |
| <b>J02</b> | pin cpl.                   | STAR 02./.., 03./.. | 46 9 020 50 300/1 |
|            |                            | STAR 05./.., 07./.. | 46 9 050 50 300/1 |
|            |                            | STAR 09./..         | 46 9 090 50 300/1 |
|            |                            | STAR 11./..         | 46 9 110 50 300/1 |
|            |                            |                     |                   |
|            |                            |                     |                   |

## M – Suspension eyes

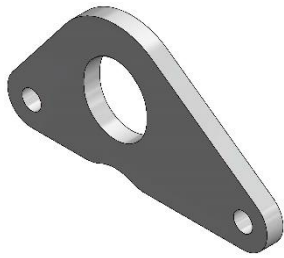

**M01**

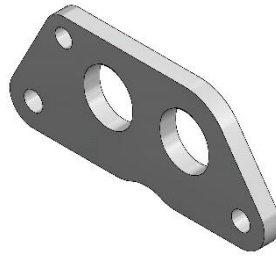

**M02**



**M03**

| Code       | Description                             | Version             |         | Order number      |                   |
|------------|---|---------------------|---------|-------------------|-------------------|
| <b>M01</b> | single hole suspension eye              | STAR 02./... 030/50 | 500 kg  | 55 0 020 50 003/0 |                   |
|            |   | STAR 030/..         | 1000 kg | 55 0 030 50 004/1 |                   |
|            |   | STAR 05./..         | 1000 kg | 55 0 050 50 002/0 |                   |
|            |   | STAR 07./..         | 2000 kg | 55 0 070 50 004/0 |                   |
|            |   | STAR 070/56         | 2500 kg | 55 0 070 56 004/0 |                   |
|            |   | STAR 09./..         | 3200 kg | 55 0 090 50 004/0 |                   |
|            |   | STAR 11./..         | 6300 kg | 55 0 110 50 003/0 |                   |
| <b>M02</b> | suspension eye<br>(with two bore holes) | STAR 02./... 030/50 | 500 kg  | 55 0 020 50 002/1 |                   |
|            |   | STAR 030/..         | 1000 kg | N1                | 55 0 030 50 001/0 |
|            |   |                     |         | S1                | 55 0 030 50 002/0 |
|            |   |                     |         | S2                | 55 0 030 50 003/0 |
|            |   | STAR 05./..         | 500 kg  | 55 0 070 50 001/0 |                   |
|            |   | STAR 050/53         | 1000 kg | N1                | 55 0 070 50 001/0 |
|            |   |                     |         | S1                | 55 0 070 50 002/0 |
|            |   |                     |         | S2                | 55 0 070 50 003/0 |
|            |   | STAR 07./..         | 2000 kg | N1                | 55 0 070 50 001/0 |
|            |   |                     |         | S1                | 55 0 070 50 002/0 |
|            |   |                     |         | S2                | 55 0 070 50 003/0 |
|            |   | STAR 070/56         | 2500 kg | N1                | 55 0 070 56 001/0 |
|            |   |                     |         | S1                | 55 0 070 56 002/0 |
|            |   |                     |         | S2                | 55 0 070 56 003/0 |
|            |   | STAR 09./..         | 3200 kg | N1                | 55 0 090 50 001/0 |
|            |   |                     |         | S1                | 55 0 090 50 002/0 |
|            |   |                     |         | S2                | 55 0 090 50 003/0 |
|            |   | STAR 11./..         | 6300 kg | N1                | 55 0 110 50 001/0 |
| S1         | 55 0 110 50 001/0                       |                     |         |                   |                   |
| S2         | 55 0 110 50 002/0                       |                     |         |                   |                   |
| <b>M03</b> | set of bolts                            | STAR 02./... 03./.. |         | 03 9 020 50 210/0 |                   |
|            |   | STAR 05./... 07./.. |         | 03 9 070 50 210/0 |                   |
|            |   | STAR 070/56         |         | 03 9 070 56 210/0 |                   |
|            |   | STAR 09./..         |         | 03 9 090 50 210/0 |                   |
|            |   | STAR 11./..         |         | 03 9 110 50 210/0 |                   |

## N – Hook suspension



N01



N0101



N02

| Code  | Description     | Version              |               | Order number      |
|-------|-----------------|----------------------|---------------|-------------------|
| N01   | hook suspension | STAR 02./.., 03./..  | rotatable     | 56 2 020 50 SW0/0 |
|       |                 |                      | non-rotatable | 56 2 020 51 SW0/0 |
|       |                 | STAR 05./..          | rotatable     | 56 2 050 50 SW0/0 |
|       |                 |                      | non-rotatable | 56 2 050 51 SW0/0 |
|       |                 | STAR 07./..          | rotatable     | 56 2 070 50 SW0/0 |
|       |                 |                      | non-rotatable | 56 2 070 51 SW0/0 |
|       |                 | STAR070/56           | rotatable     | 56 2 070 56 SW0/0 |
|       |                 |                      | non-rotatable | 56 2 070 57 SW0/0 |
|       |                 | STAR 09./..          | rotatable     | 56 2 090 50 SW0/0 |
|       |                 |                      | non-rotatable | 56 2 090 51 SW0/0 |
|       |                 | STAR 11./..          | rotatable     | 56 2 110 50 SW0/0 |
|       |                 |                      | non-rotatable | 56 2 110 51 SW0/0 |
| N0101 | safety latch    | STAR 02./.. – 05./.. |               | 20 9 020 50 003/0 |
|       |                 |                      |               | 20 9 070 50 003/1 |
|       |                 | STAR 09./..          |               | 20 9 090 50 003/0 |
|       |                 | STAR 11./..          |               | 20 9 110 50 003/1 |
|       |                 |                      |               |                   |
| N02   | set of bolts    | STAR 02./.., 03./..  |               | 03 9 020 50 210/0 |
|       |                 |                      |               | 03 9 070 50 210/0 |
|       |                 | STAR 07./..          |               | 03 9 070 50 210/0 |
|       |                 |                      |               | 03 9 070 56 210/0 |
|       |                 | STAR 09./..          |               | 03 9 090 50 210/0 |
|       |                 | STAR 11./..          |               | 03 9 110 50 210/0 |

## O – Hook block

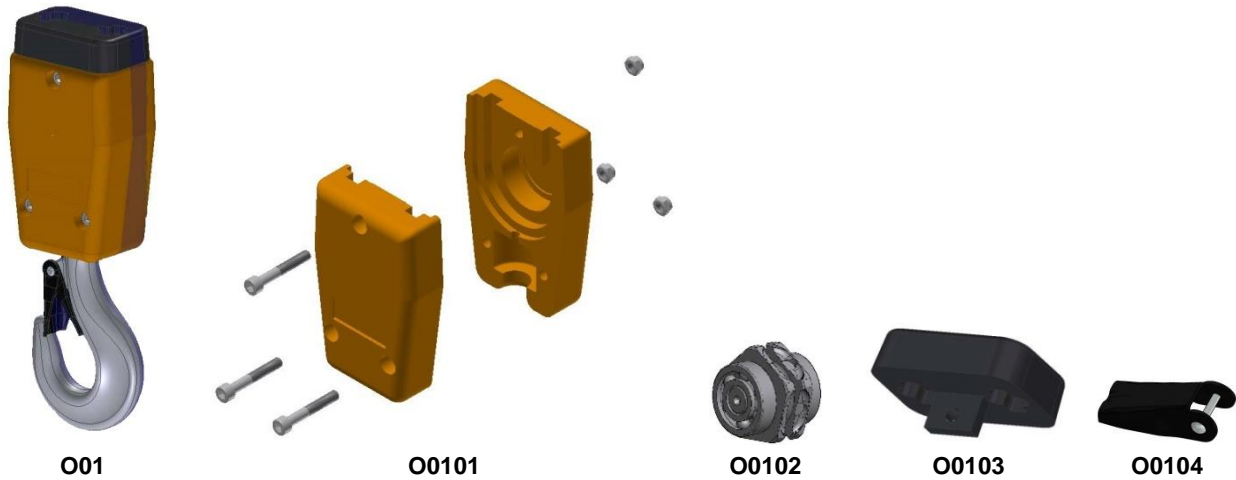

| Code         | Description            | Version      | Order number      |                   |
|--------------|------------------------|--------------|-------------------|-------------------|
| <b>O01</b>   | hook block cpl.        | 4x12         | 20 2 020 50 000/0 |                   |
|              |                        | 5,2x15       | 20 2 030 50 000/0 |                   |
|              |                        | 7,2x21       | 2000 kg           | 20 2 070 50 000/0 |
|              |                        |              | 2500 kg           | 20 2 070 56 000/0 |
|              |                        | 9x27         |                   | 20 2 090 50 000/1 |
| <b>O0101</b> | casing hook block cpl. | 11,3x31      | 20 2 110 50 000/0 |                   |
|              |                        | 4x12, 5,2x15 | 20 9 020 50 001/0 |                   |
|              |                        | 7,2x21       | 20 9 070 50 001/2 |                   |
|              |                        | 9x27         | 20 9 090 50 001/1 |                   |
| <b>O0102</b> | sprocket wheel         | 11,3x31      | 20 9 110 50 001/0 |                   |
|              |                        | 4x12         | 20 2 020 50 005/0 |                   |
|              |                        | 5,2x15       | 20 2 030 50 005/0 |                   |
|              |                        | 7,2x21       | 2000 kg           | 20 2 070 50 005/0 |
|              |                        |              | 2500 kg           | 20 2 070 56 005/0 |
| <b>O0103</b> | rubber buffer          | 9x27         | 20 2 090 50 005/0 |                   |
|              |                        | 11,3x31      | 20 2 110 50 005/0 |                   |
|              |                        | 4x12, 5,2x15 | 20 0 020 50 014/0 |                   |
|              |                        | 7,2x21       | 20 0 070 50 014/0 |                   |
| <b>O0104</b> | safety latch cpl.      |              | from ca. 05/2011  | 20 0 070 50 014/2 |
|              |                        | 9x27         |                   | 20 0 090 50 014/1 |
|              |                        | 11,3x31      |                   | 20 0 110 50 014/0 |
|              |                        | 4x12, 5,2x15 |                   | 20 9 020 50 003/0 |
| <b>O0104</b> | safety latch cpl.      | 7,2x21       | 20 9 070 50 003/1 |                   |
|              |                        | 9x27         | 20 9 090 50 003/0 |                   |
|              |                        | 11,3x31      | 20 9 110 50 003/1 |                   |

## P – Hook tackle

### Version STAR 02./.. – 05./..



P01



P0101



P0102

| Code  | Description               | Version       | Order number      |
|-------|---------------------------|---------------|-------------------|
| P01   | hook tackle Skeletto cpl. | 4x12          | 15 2 020 50 000/0 |
|       |                           | 5,2x15        | 15 2 030 50 000/0 |
| P0101 | rubber buffer             |               | 35 S0015 00300    |
| P0102 | safety latch cpl.         | Skeletto R012 | 15 9 020 50 003/1 |
|       |                           | RSN 012       | 15 9 020 50 003/0 |

### Version STAR 07./..



P01



P0101



P0102

| Code  | Description       | Version | Order number      |
|-------|-------------------|---------|-------------------|
| P01   | hook tackle cpl.  | 7,2x21  | 15 2 070 50 000/3 |
| P0101 | rubber buffer     |         | 35 00015 00700    |
| P0102 | safety latch cpl. |         | 20 9 020 50 003/0 |

## Version STAR 09./..



**P01**



**P0101**



**P0102**

| Code  | Description       | Version | Order number      |
|-------|-------------------|---------|-------------------|
| P01   | hook tackle cpl.  | 9x27    | 15 2 090 50 000/1 |
| P0101 | rubber buffer     |         | 35 S0015 00901    |
| P0102 | safety latch cpl. |         | 20 9 070 50 003/1 |

## Version STAR 11./..

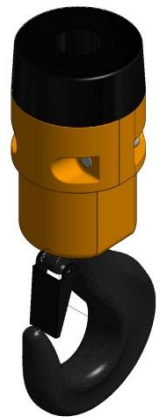

**P01**

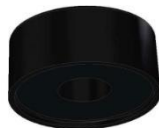

**P0101**



**P0102**

| Code  | Description       | Version | Order number      |
|-------|-------------------|---------|-------------------|
| P01   | hook tackle cpl.  | 11,3x31 | 15 2 110 50 000/0 |
| P0101 | rubber buffer     |         | 35 00015 01100    |
| P0102 | safety latch cpl. |         | 20 9 090 50 003/0 |



## Q – Lift limiter

### Version STAR 02./.. – 05./..



**Q01**



**Q0101**

| Code         | Description       | Version | order number      |
|--------------|-------------------|---------|-------------------|
| <b>Q01</b>   | lift limiter cpl. | 4x12    | 03 2 020 50 010/1 |
|              |                   | 5,2x15  | 03 2 030 50 010/1 |
| <b>Q0101</b> | rubber buffer     |         | 35 S001 00300     |

### Version STAR 07./..



**Q01**



**Q0101**

| Code         | Description       | Version | Order number      |
|--------------|-------------------|---------|-------------------|
| <b>Q01</b>   | lift limiter cpl. | 7,2x21  | 03 2 070 50 010/0 |
| <b>Q0101</b> | rubber buffer     |         | 35 S001 00700     |

### Version STAR 09./..



**Q01**



**Q0101**

| Code         | Description       | Version | Order number      |
|--------------|-------------------|---------|-------------------|
| <b>Q01</b>   | lift limiter cpl. | 9x27    | 03 2 090 50 010/0 |
| <b>Q0101</b> | rubber buffer     |         | 35 S0015 00901    |

### Version STAR 11./..

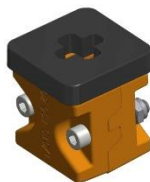

**Q01**



**Q0101**

| Code         | Description       | Version | Order number      |
|--------------|-------------------|---------|-------------------|
| <b>Q01</b>   | lift limiter cpl. | 11,3x31 | 03 2 110 50 010/1 |
| <b>Q0101</b> | rubber buffer     |         | 35 S0015 00901    |

## R – Chain box

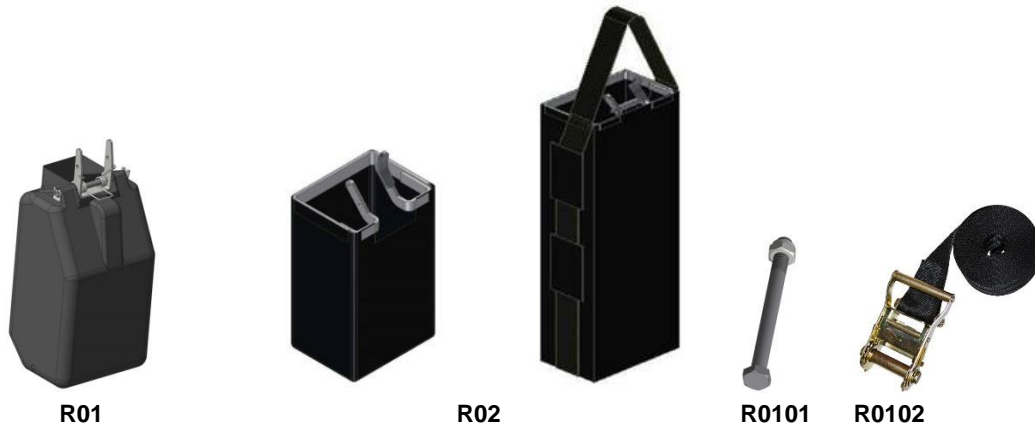

| Code         | Description                      | Version                     | Chain/Meter          |                   | Order number      |                   |
|--------------|----------------------------------|-----------------------------|----------------------|-------------------|-------------------|-------------------|
| <b>R01</b>   | chain box plastic                | STAR 02./..., 03./..        | 4/12                 | 5/8               | 30 2 020 50 000/1 |                   |
|              |                                  |                             | 4/16                 | 5/10              | 30 2 030 50 000/1 |                   |
|              |                                  | STAR 05./..., 07./..        | 5/8                  | 7/5               | 30 2 050 51 000/1 |                   |
|              |                                  |                             | 5/10                 | 7/8               | 30 2 050 50 000/1 |                   |
| <b>R02</b>   | chain box canvas                 | STAR 02./..., 03./..        | 4/10                 | 5/8               | 30 2 030 50 000/2 |                   |
|              |                                  |                             | 4/20                 | 5/18              | 30 2 030 51 000/0 |                   |
|              |                                  |                             | 4/30                 |                   | 30 2 030 52 000/0 |                   |
|              |                                  |                             | 4/40                 | 5/25              | 30 2 030 53 000/0 |                   |
|              |                                  |                             | 4/50                 | 5/40              | 30 2 030 54 000/0 |                   |
|              |                                  |                             | 4/80                 | 5/60              | 30 2 030 56 000/0 |                   |
|              |                                  |                             |                      | 5/70              | 30 2 030 57 000/0 |                   |
|              |                                  |                             |                      | 5/90              | 30 2 030 58 000/0 |                   |
|              |                                  |                             | STAR 05./..., 07./.. | 5/8               |                   | 30 2 050 50 000/0 |
|              |                                  |                             |                      | 5/18              | 7/8               | 30 2 050 51 000/0 |
|              |                                  | 5/25                        |                      | 7/18              | 30 2 050 52 000/0 |                   |
|              |                                  | 5/40                        |                      | 7/24              | 30 2 050 53 000/0 |                   |
|              |                                  | 5/50                        |                      |                   | 30 2 050 54 000/0 |                   |
|              |                                  | 5/60                        |                      | 7/30              | 30 2 050 55 000/0 |                   |
|              |                                  | 5/70                        |                      |                   | 30 2 050 56 000/0 |                   |
|              |                                  | 5/90                        |                      |                   | 30 2 050 58 000/0 |                   |
|              |                                  |                             |                      | 7/40              | 30 2 070 57 000/0 |                   |
|              |                                  |                             |                      | 7/50              | 30 2 070 59 000/0 |                   |
|              |                                  |                             | 7/60                 | 30 2 070 60 000/0 |                   |                   |
|              |                                  | STAR 09./..., 11./..        | 9/10                 | 11/6              | 30 2 110 50 000/0 |                   |
| 9/18         | 11/12                            |                             | 30 2 110 51 000/0    |                   |                   |                   |
| 9/30         | 11/20                            |                             | 30 2 110 54 000/0    |                   |                   |                   |
| 9/40         | 11/25                            |                             | 30 2 110 56 000/0    |                   |                   |                   |
| 9/50         | 11/30                            |                             | 30 2 110 57 000/0    |                   |                   |                   |
| 9/60         | 11/40                            |                             | 30 2 110 58 000/0    |                   |                   |                   |
|              | 9/75                             | 11/50                       | 30 2 110 59 000/0    |                   |                   |                   |
| <b>R0101</b> | fastening screw                  | STAR 02./..., 03./..        |                      |                   | 30 9 020 50 100/0 |                   |
|              |                                  | STAR 05./..., 07./..        |                      |                   | 30 9 050 50 100/0 |                   |
|              |                                  | STAR 09./..., 11./..        |                      |                   | 30 9 110 50 100/0 |                   |
| <b>R0102</b> | set-discharge tape for chain bag | for chain weight over 25 kg |                      |                   | 30 9 030 54 012/0 |                   |

## Chain box "Flip Bag"

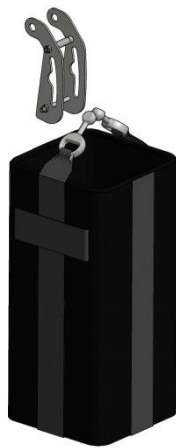

R03



R0301



R0302

### Version STAR 02./.., 03./..

| Code  | Description          | Version          |       | Order number      | Order number   |
|-------|----------------------|------------------|-------|-------------------|----------------|
|       |                      | Chain/Meter      |       | complete (R03)    | single (R0301) |
| R03 / | chain box "Flip Bag" | 4/12             | 5/8   | 30 2 020 50 230/0 | 30 2 160 230/0 |
| R0301 |                      | 4/20             | 5/18  | 30 2 020 50 300/0 | 30 2 160 300/0 |
|       |                      | 4/40             | 5/25  | 30 2 020 50 400/0 | 30 2 160 400/0 |
|       |                      | 4/50             | 5/40  | 30 2 020 50 500/0 | 30 2 160 500/0 |
|       |                      | 4/80             | 5/60  | 30 2 020 50 600/0 | 30 2 160 600/0 |
|       |                      | 4/100            | 5/75  | 30 2 020 50 650/0 | 30 2 160 650/0 |
|       |                      |                  | 5/100 | 30 2 020 50 700/0 | 30 2 160 700/0 |
| R0302 |                      | set of fastening |       |                   |                |

### Version STAR 05./..

| Code  | Description          | Version     |                   | Order number      | Order number      |
|-------|----------------------|-------------|-------------------|-------------------|-------------------|
|       |                      | Chain/Meter |                   | complete (R03)    | single (R0301)    |
| R03 / | chain box "Flip Bag" | 5/8         | 7/5               | 30 2 050 50 230/0 | 30 2 180 230/0    |
| R0301 |                      | 5/18        | 7/8               | 30 2 050 50 300/0 | 30 2 180 300/0    |
|       |                      | 5/25        | 7/18              | 30 2 050 50 400/0 | 30 2 180 400/0    |
|       |                      | 5/40        | 7/24              | 30 2 050 50 500/0 | 30 2 180 500/0    |
|       |                      | 5/60        | 7/30              | 30 2 050 50 600/0 | 30 2 180 600/0    |
|       |                      | 5/75        | 7/40              | 30 2 050 50 650/0 | 30 2 180 650/0    |
|       |                      | 5/100       | 7/50              | 30 2 050 50 700/0 | 30 2 180 700/0    |
|       |                      |             | 7/60              | 30 2 050 50 800/0 | 30 2 180 800/0    |
|       |                      | 7/70        | 30 2 050 50 900/0 | 30 2 180 900/0    |                   |
| R0302 | set of fastening     |             |                   |                   | 30 2 050 50 002/0 |

## Version STAR 07./..

| Code                   | Description          | Version           |                | Order number<br>complete (R03) | Order number<br>single (R0301) |
|------------------------|----------------------|-------------------|----------------|--------------------------------|--------------------------------|
|                        |                      | Chain/Meter       |                |                                |                                |
| <b>R03 /<br/>R0301</b> | chain box "Flip Bag" | 5/8               | 7/5            | 30 2 070 50 230/0              | 30 2 180 230/0                 |
|                        |                      | 5/18              | 7/8            | 30 2 070 50 300/0              | 30 2 180 300/0                 |
|                        |                      | 5/25              | 7/18           | 30 2 070 50 400/0              | 30 2 180 400/0                 |
|                        |                      | 5/40              | 7/24           | 30 2 070 50 500/0              | 30 2 180 500/0                 |
|                        |                      | 5/60              | 7/30           | 30 2 070 50 600/0              | 30 2 180 600/0                 |
|                        |                      | 5/75              | 7/40           | 30 2 070 50 650/0              | 30 2 180 650/0                 |
|                        |                      | 5/100             | 7/50           | 30 2 070 50 700/0              | 30 2 180 700/0                 |
|                        |                      |                   | 7/60           | 30 2 070 50 800/0              | 30 2 180 800/0                 |
|                        | 7/70                 | 30 2 070 50 900/0 | 30 2 180 900/0 |                                |                                |
| <b>R0302</b>           | set of fastening     |                   |                |                                | 30 2 070 50 002/0              |

## Version STAR 09./..

| Code                   | Description          | Version     |  | Order number<br>complete (R03) | Order number<br>single (R0301) |
|------------------------|----------------------|-------------|--|--------------------------------|--------------------------------|
|                        |                      | Chain/Meter |  |                                |                                |
| <b>R03 /<br/>R0301</b> | chain box "Flip Bag" | 9/10        |  | 30 2 090 50 350/0              | 30 2 230 350/0                 |
|                        |                      | 9/18        |  | 30 2 090 50 480/0              | 30 2 230 480/0                 |
|                        |                      | 9/30        |  | 30 2 090 50 600/0              | 30 2 230 600/0                 |
|                        |                      | 9/40        |  | 30 2 090 50 700/0              | 30 2 230 700/0                 |
| <b>R0302</b>           | set of fastening     |             |  |                                | 30 2 090 50 002/0              |

## Version STAR 11./..

| Code                   | Description          | Version     |  | Order number<br>complete (R03) | Order number<br>single (R0301) |
|------------------------|----------------------|-------------|--|--------------------------------|--------------------------------|
|                        |                      | Chain/Meter |  |                                |                                |
| <b>R03 /<br/>R0301</b> | chain box "Flip Bag" | 11/6        |  | 30 2 110 50 350/0              | 30 2 230 350/0                 |
|                        |                      | 11/12       |  | 30 2 110 50 480/0              | 30 2 230 480/0                 |
|                        |                      | 11/20       |  | 30 2 110 50 600/0              | 30 2 230 600/0                 |
|                        |                      | 11/25       |  | 30 2 110 50 700/0              | 30 2 230 700/0                 |
|                        |                      | 11/30       |  | 30 2 110 50 800/0              | 30 2 230 800/0                 |
| <b>R0302</b>           | set of fastening     |             |  |                                | 30 2 110 50 002/0              |



This catalog supersedes all previous editions, which thereby become invalid.  
Subject to change