

**Graphite COVA**

---

**BEARING AND SEALING COMPONENTS**

---

**FOR MECHANICAL ENGINEERING**

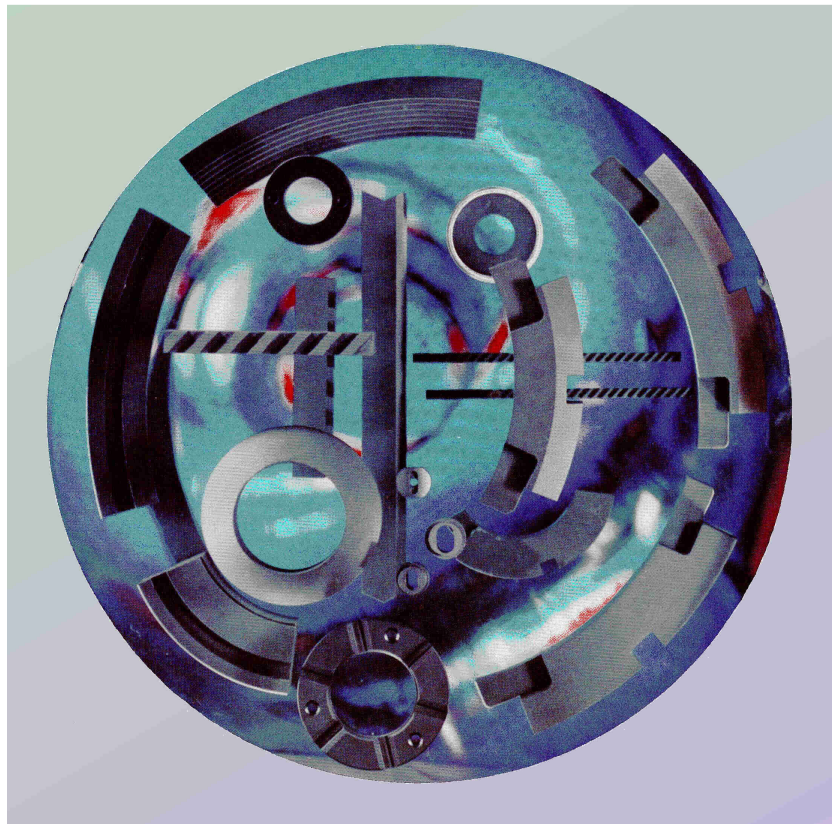

**Graphite COVA GmbH**

---

# Graphite COVA Bearing and Sealing Components for Mechanical Engineering

## Introduction

Carbon and graphite materials are a proven method for the sealing of shafts and their bearings.

The special physical and mechanical properties of carbon and graphite, in particular their low coefficient of friction, hard wearing and excellent thermal resistance offer solutions to many mechanical engineering and manufacturing problems.

Bearings, sealing rings and vanes made of carbon and graphite may be used for dry or wet running applications. Their use is recommended where the following conditions prevail:

- the use of hydro carbon lubricants is prevented by high operating temperatures
- oil or other lubricating contamination must be restricted
- chemical attack prohibits the use of other materials
- minimum servicing requirement
- dry running and high pressure demands a mechanically sound material with sufficient self-lubricating capability, good thermal conductivity and low coefficient of expansion
- bearings are situated vertically or at an angle in the machine thus making lubricant retention difficult

Bearings and sealing elements made from Graphite COVA materials give the designer many opportunities for solving difficult bearing and sealing problems.

## Contact

---

Postal address      Gruenthal 1 - 6  
                                 D-90552 Röthenbach/Pegnitz

Phone:                +49 911 5708 – 283  
Fax:                    +49 911 5708 - 211  
E-Mail:                specials@graphitecova.com

**Graphite COVA GmbH**



# General Application Information

## Physical and Mechanical Properties

- good dimensional stability (low thermal coefficient of expansion)
- good heat conductivity
- good corrosive resistance
- good temperature resistance
- good self-lubrication
- good frictional characteristics
- good machining characteristics
- low weight

## Operating Temperature

The temperature resistance in an oxidising atmosphere can be specified as 500°C maximum for GraphiteCOVA bearing qualities. In a non-oxidising atmosphere the temperature resistance is determined by the final graphitising treatment of each individual grade (e.g. upper application limit for graphite is approximately 3000°C). Temperature resistance is also affected by various impregnations. In the case of resin impregnation the maximum operating temperature is 180°C, for lead impregnation 200°C and antimony impregnation 500°C.

## Chemical Resistance

Carbon and particularly graphite are characterised by excellent chemical resistance to almost all organic and inorganic media. Exceptions to this are some strongly oxidising acids, alkaline solutions, halogens and alkali molten metals.

## Frictional Behaviour

Graphite has self-lubricating properties because of its crystalline structure. The low friction coefficient is a function of the low bonding between the structural lattice planes. Dislocation of one against the other is therefore easy. The friction coefficient is particularly low if traces of water or other vapours are present. The friction coefficient is greatly increased when a vacuum is created.

Because of the varying conditions of application, no exact data can be given for friction coefficients. In general the following values can be expected for sliding friction:

- |                       |               |
|-----------------------|---------------|
| a) dry friction       | 0.10... 0.30  |
| b) mixed friction     | 0.05 ...0.10  |
| c) hydraulic friction | 0.01 ... 0.05 |

The frictional behaviour of carbon and graphite is also affected by the following factors:

- running in
- specific pressure
- running speed

When running in carbon and graphite bearings, the friction coefficient drops until a constant value is reached once the surfaces are smoothed.

The coefficient of friction also drops in the case of constant specific strain and increasing running speed, or at the inverse (See page 5, Figs. 1 ... 3).

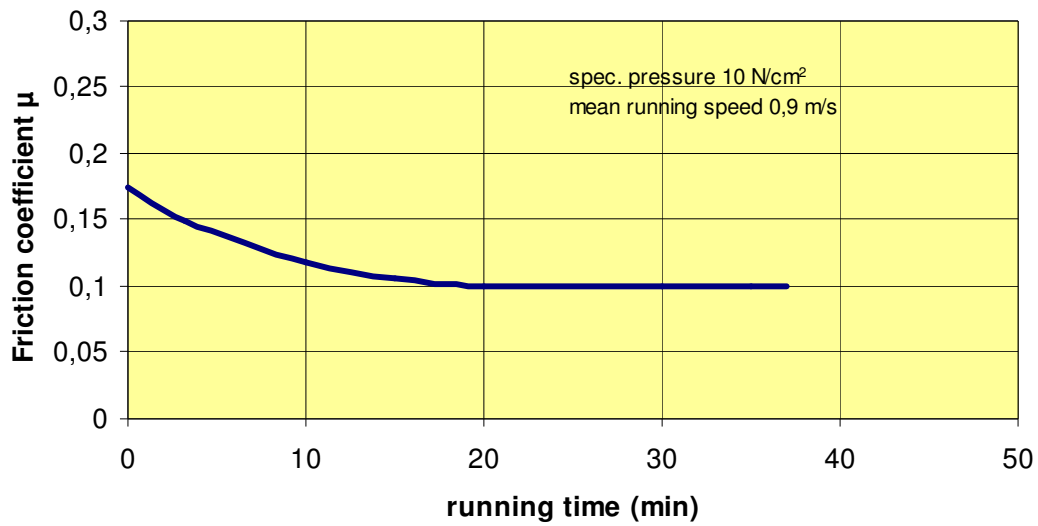

Fig. 1 Change of the friction coefficient  $\mu$  when running in

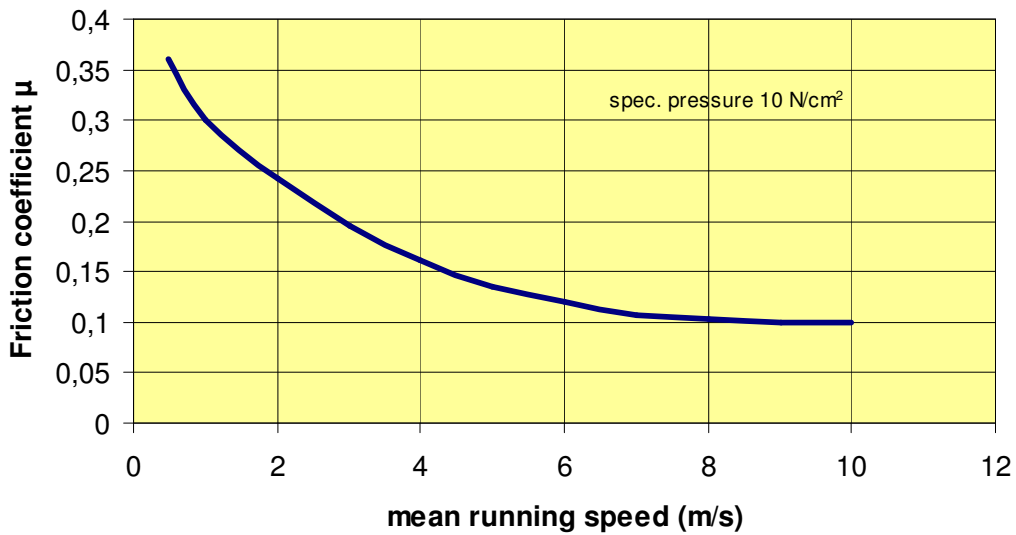

Fig. 2 Friction coefficient  $\mu$  dependent on the mean running speed

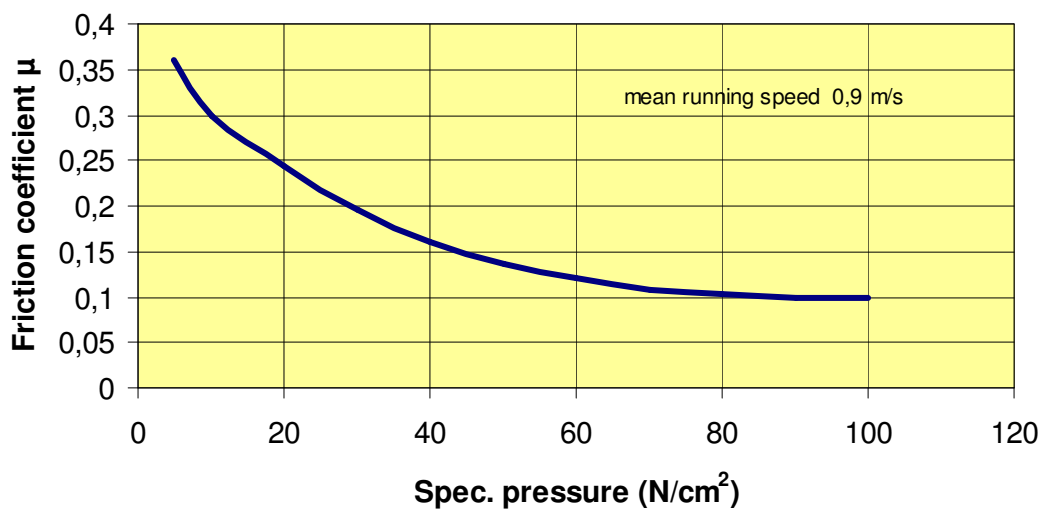

Fig. 3 Friction coefficient  $\mu$  dependent on the specific pressure

## Construction Information

The good machining properties of graphite give the designer full scope in producing practical designs.

The following guidelines should be observed:

### Wall thickness:

The choice of wall thickness depends on mechanical aspects. Based on practical operating experience, the graphite bearings should have wall thicknesses which correspond roughly to the empirical equation  $S = 0.13d + 2.8 \geq 3$  (mm)

### Bearing length:

To avoid excessive edge pressure and internal stress in the bearing  $L = d$ ;  $L \leq 2d$  is recommended. The height for washers is recommended as  $L = 0.1 D \cdot L \geq 3$  (mm).

### Flanges:

Flange thickness  $b$  should be at least as much as wall thickness  $s$  ( $b \geq s$ ). Flange connections should be radiused and adjoining surfaces machined.

### As a general rule:

No sharp corners, should be broken or radiused. Shapes should be as simple as possible.

## Counter Face Materials

Suitable:                    grey cast iron  
                                  plain steel  
                                  alloyed steel (chrome steel)  
                                  hard metal  
                                  ceramic  
                                  glass

Suitable under certain conditions:  
                                  nonferrous heavy metal  
                                  chrome nickel steel  
                                  chromium plate materials

unsuitable:                aluminium and its alloys

## Surface Quality of the Counter Face Materials

The surface quality of the counter face materials has an important influence on the durability of carbon and graphite. Counter face surfaces with a maximum surface roughness of  $S_r < 1 \mu\text{m}$  are recommended. For high pressure lapped and superfinished counter faces with a maximum surface roughness of  $S_r < 0.5 \mu\text{m}$  are necessary.

## General Guidelines for the Treatment of Carbon and Graphite

Carbon and graphite can be machined to fine tolerances on most machines and machine tools. The work piece remains both structurally and dimensionally stable.

**Extraction:** Care must be taken that all dust is extracted during machining (e.g. by an industrial vacuum cleaner with a rating of at least 30 mbar and 20 m/s air speed). Lubricated machine driving elements must be covered, moving parts or platens must be kept grease and oil free.

**Cooling:** The use of cutting lubricants and cooling agents is not recommended. Water may be used as a coolant for honing, lapping and occasionally for cutting and separating.

**Clamping:** The parts must be carefully and lightly clamped, the clamping pressure should be distributed over as large an area as possible. Parts with a low wall thickness (<0.1 d or <10 mm) must be pre-pared internally with collet chucks or expanding rings. For external treatment it is advisable to place the part on a mandrel.

**Tools:** The following values generally apply to all turning, drilling and milling tools: clearance angle  $\alpha$ : 15° ... 25°; wedge angle  $\beta$ : 65° ... 75°; tool orthogonal plane  $\gamma$ :  $\pm 2^\circ$ ; large cutting radii prevent chipping of the work piece. The use of K 05 and K 10 types of hard metal and diamond tools are recommended.

## Cutting Rates

**Sawing:** High-speed steel and bimetal-cutting band sawblades 3 teeth per inch

Cutting speed: 100 m/min

**Grinding:** Silicon carbide wheels, grain 36 ... 60  $\mu\text{m}$

Cutting speed: 20 ... 30 m/s

Diamond cutting wheels, grain 100 ... 200  $\mu\text{m}$

Galvanic and bronze bonding

Cutting speed: 30 ... 50 m/s

### Turning:

	Tools K 10HardMetal	Cutting Speed m/min	Forward Feed mm/r	Cutting Depth mm
Carbon	Roughing	100 ...150	0.10...0.20 :	upto15
	Smoothing	150 ...200	0.05 ...0.15	0.10...0.30
Graphite	Roughing	100 ...200	0.20 ...0.50	up to 25
	Smoothing	200 ...400	0.05 ...0.20	0.10...0.50

### Drilling:

	Tools K 10HardMetal	Cutting Speed m/min	Forward Feed mm/r	
Carbon		80	0.10...0.30	
Graphite		150...300	0.10...0.50	

**Milling:**

	Tools K 10 Hard Metal	Cutting Speed m/min	Forward Feed mm/min	Cutting Depth mm
Carbon	Roughing	50 ...100	100... 200	3
	Smoothing	100	100... 200	0.2... 1.0
Graphite	Roughing	50 ...150	150... 1000	15...30
	Smoothing	100 ...200	150... 600	0.2...2

**Grinding:**

	Tools	Cutting Speed m/s	Forward Feed mm/min	Cutting Depth mm
Carbon	Silicon Carbon Grain 24 - 60 Hardness F - J Texture 6 - 9	20 ...30	200 ... 400	0.05... 5
Graphite		20 ...35	500...2000	0.05.,. 10

Carbon and graphite can be easily lapped and honed allowing fine tolerances.

**GraphiteCOVA Bearings**

The use of carbon and graphite bearings has proved successful in the areas of mechanical and process engineering. The use of GraphiteCOVA bearing materials is recommended for the following conditions:

- At high and low temperatures, where usual lubricants cannot be used.
- In media with unfavourable lubricating properties (aqueous solutions, gasoline, liquid gases, water).
- In corrosive media which prohibit the use of bearings made of other materials.
- When the finished product must not be contaminated with liquid lubricants (food, drugs).
- When dry running is preferable to the use of liquid lubricants because of surrounding conditions.
- Bearings with alternating wet/dry running.
- Concealed machine bearings which cannot be maintained.

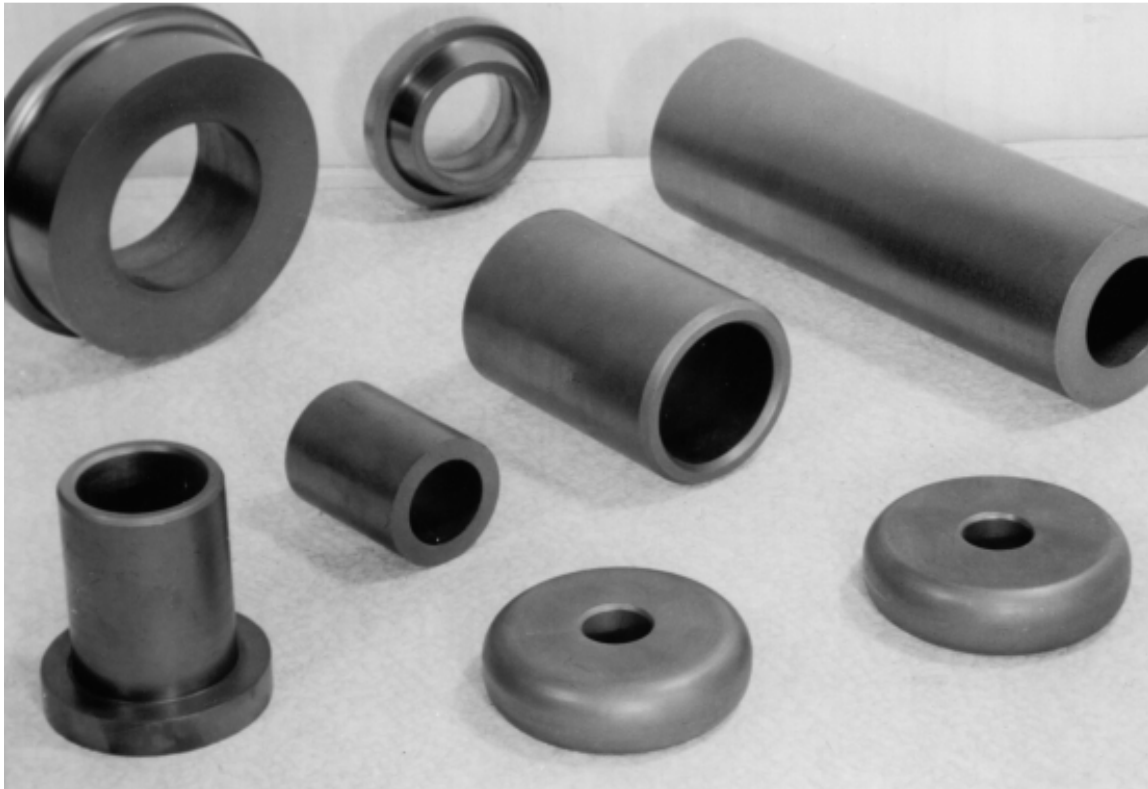

Fig. 4 Cylinder, collar and concave bearing designs

## Guidelines for the Installation and Design of Bearings

The design of radial bearings and collar bearings of carbon and graphite is determined by DIN 1850, Section 4, „Bushes for slide bearings made of artificial carbon“. Instructions for the location of lubrication grooves are contained in DIN 1850, Section 2 and DIN 1591.

It is recommended that bores are smooth for dry-running radial and axial bearings. Wet running carbon radial bearings can be provided with longitudinal grooves specific to each case. Grooves are recommended for wet running axial bearings.

Normally the bearings are shrunk or pressed directly into the housing or into metal bushings. The low thermal expansion coefficient of carbon and graphite ( $3 \dots 5 \times 10^{-6}/K$ ) must be taken into account when shrinking or pressing in the bearings.

### Cold Pressing

For a cold press fit in steel, where the application is lower than 100°C steel housings made to H7 bore tolerance are normally recommended. If the housing material has a higher coefficient of thermal expansion than steel the temperature limitation is normally lower.

When pressing the bearing into its housing a mandrel with collar whose diameter is approximately three tolerances below the drilling tolerance of the carbon bearings as supplied should be used to press the bearings in. The bore diminishes by 70 - 85% of the pressing over-dimension according to the quality and dimension of the bearing.



## Shrinking

We recommend shrinking directly into the metal housing for carbon bearings which are to be used at operational temperatures of over 100°C. To shrink in the bearings, experience has shown that the tolerance overlap should be in the range corresponding to H7/x8 ... z8. The selected heating temperature for mounting must be sufficiently high to allow the cold bearing to be easily inserted. On shrinking, the carbon bearing bore diminishes by approximately 80 ... 100 % of the shrinking over-dimension. In the case of the above mentioned shrink fits H7/x8 ... z8, this diminishes according to the wall thickness ratio. In order to keep to exact tolerances it is advisable to machine the bearing bore to size after shrinking.

## Adhesives

Adhesives are only suitable for bearings which are subject to low temperatures (up to 200°C). Bonding to the housing with commercially available adhesives (e.g. Technicol 8280) is possible. For higher temperatures GraphiteCOVA special coking adhesives should be used.

## Bearing Clearance

In general carbon bearings require slightly more clearance than oil-lubricated bearings. The following values should be observed.

Wet running: 1 ... 3‰ of shaft diameter at operational temperature

Dry running: 3 ... 5‰ of shaft diameter at operational temperature

## Recommended Pressure Surface Speed

The permissible bearing pressure is determined by the surface speed of the shaft and the friction ratio of the carbon or graphite bearings. The permissible pressure values for dry-running bearings have been determined by laboratory trials. The corresponding values can be seen in the following  $p \cdot v$ -diagram (Fig. 5). The permissible bearing wear rate was selected as 1 (chrome steel)  $\mu\text{m}/\text{h}$ . In practice the media often increases lubrication. This means that the values in the  $p \cdot v$ -diagram can be increased considerably whilst wear remains constant.

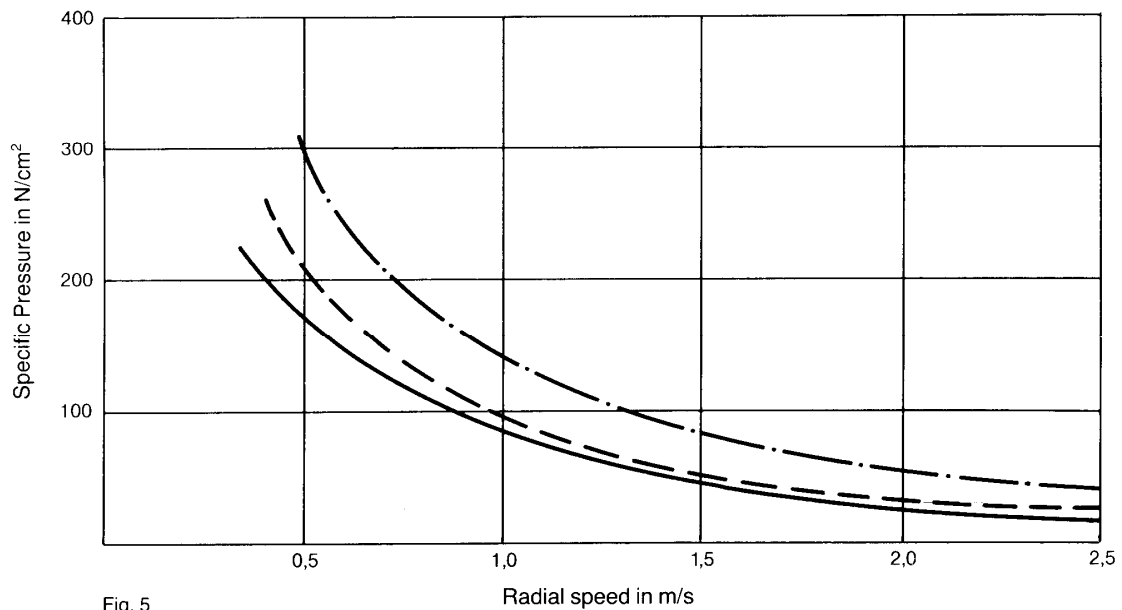
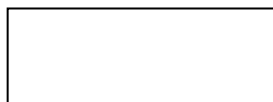

Fig. 5  
p · v-diagram  
Slide bearings



Graphite bearing without impregnation  
 Graphite bearing with synthetic resin impregnation  
 Graphite bearing with metal impregnation

Test conditions at room temperature:

Radial bearings: Ø22/14.7 x 17.7  
 Shaft: Chrome steel 1.4034  
 Shaft treatment: Sr ≤ 0.5 µm

## GraphiteCOVA Segmented Seals

GraphiteCOVA carbon and graphite seals have been used successfully in mechanical engineering for many years. Because of their self-lubricating properties and good corrosion and thermal resistance, GraphiteCOVA seals are used for rotating and reciprocating parts.

GraphiteCOVA seals are particularly suitable for the following application conditions where:

- the medium must not be contaminated by oil
- metallic sealing materials cannot be used because of the danger of corrosion or inadequate emergency running properties
- the operational temperature is outside the permissible range for lubricating oils
- the seals must work dry.

These seals can be subdivided according to the following designs (construction features):

- piston and guide rings
- sliding rings
- steam seals
- water turbine rings
- packing rings

## Installation and Design

As in the case of carbon bearings it is also of the utmost importance that the carbon seal counterfaces are finely finished. Lapped surfaces are recommended.

GraphiteCOVA carbon seals can frequently be substituted for plastic or metal seals providing our guidelines are observed.

The manufacture of one-piece rings is possible up to a diameter of 410 mm. Rings with greater diameters are produced as segment assemblies. The usual minimum number of segments can be seen from the following table.

Ring External Diameter (mm)	Number of Segments
upto 350	3
450	4
650	6
800	8
1000	12
2000	16
3000	24
4000	30

## GraphiteCOVA Piston and Guide Rings

In chemical processing technology, dry running piston compressors are becoming increasingly used for the compression of extremely cold liquified gases. Great importance is placed on good dry running properties for this process. GraphiteCOVA carbon and graphite meet these requirements fully.

One-piece, split or multi-piece rings with overlapped or tenon joints are used to seal the piston or guide rods. With GraphiteCOVA rings dry running Operation times of over 10,000 hours can be achieved for the compression of gases with normal moisture content (dew point approximately 0°C).

With drier gases the life of the piston and guide rings is reduced. (Carbon and graphite can be used to a dew point of -60°C).

Piston speed should not exceed 4m/s. Extremely high wear of the piston rings must be expected if piston speeds are high.

In order to achieve an even and long lasting sealing it is necessary to provide the counter faces with as fine a surface finish as possible, e.g. by lapping or honing. ( $S_r < 1.0 \mu\text{m}$ ). Increased surface roughness can lead to higher wear rates.

For radial sealing rings there are a number of tried and tested metal springs, the choice of materials depends on the prevailing operational conditions. The springs are used to press the carbon rings radially against the cylinder wall and must be designed for a contact pressure of approx. 1.0 ... 1.5 N/cm<sup>2</sup>.

Carbon and graphite piston rings are supplied as single rings, slit or multi piece with overlap and (if necessary) additional mortising. Fig. 6 provides a diagrammatic view of the various types of joints.

The angled butt joint (Design a) is generally preferred as it can be machined at lower cost and allows slightly lower penetration than a straight butt joint. When there are great differences in pressure and low piston speeds, either the overlapped joint (Design b) or the overlapped mortised joint (Design d) is used.

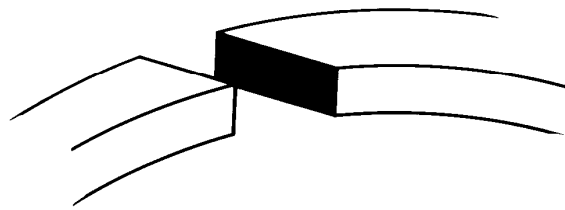

Design a  
Ring with scarfed butt joint

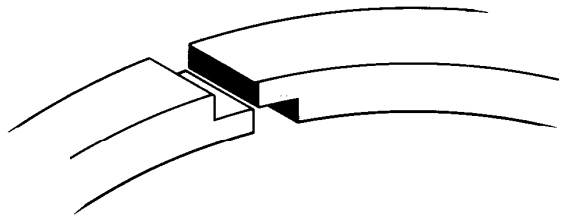

Design b  
Ring with overlapped joint

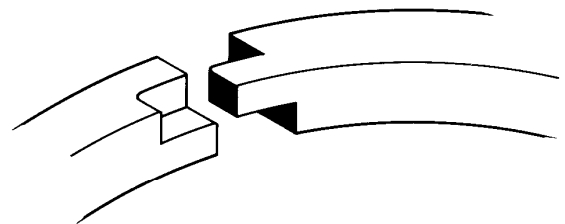

Design c  
Ring with single tenon

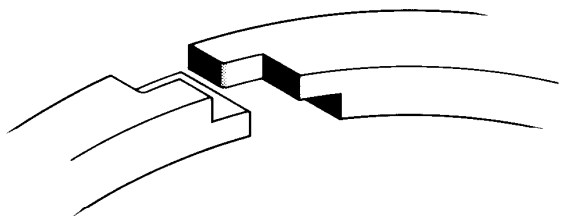

Design d  
Ring with overlapped  
tenon joint

---

Fig. 6  
Various design of split carbon and graphite rings

# GraphiteCOVA Mechanical Carbon Seal Faces

**Fields of Application:** Mechanical Engineering, Pumps, Shipbuilding, Household Appliances and Automobile Industry.

The packing glands previously used have been largely replaced by mechanical seals for axial sealing. The advantages of mechanical seals are:

- reduced loss through leakage
- longer durability
- higher operational safety

Mechanical seals are mainly used for high speed sealing between liquids and gases. For sealing against gases, chemically aggressive or strongly heated media, the use of double action mechanical seals is recommended. The trapped media between the two surfaces aids the lubrication of the two surfaces, conducts heat caused by friction and improves the sealing effect.

A mechanical seal comprises the following main components:

- fixed ring (counterface e.g. hard metal, ceramic)
- rotating mechanical seals (carbon)
- spring element (to attain contact pressure of approximately 5 ... 20 N/cm<sup>2</sup>).

The diameter of the counter face should be the same or larger than that of the carbon ring. The finish of the carbon wearing surface and of the counter face is critical to the relative wear rate. Lapped opposing surfaces have proved successful in practice.

After the running-in phase, long-term wear averages at 0.03 ... 0.20 µm/h. Since the long-term wear of mechanical carbon seals is extremely low, it is very difficult to draw conclusions from laboratory trials as to the service life of the rings because results vary greatly. The rate of wear depends upon a number of variable factors such as material combination, temperature conditions, frictional behaviour etc. In practice it has, however been seen that if the axial sliding rings are working perfectly and the correct quality is chosen, a service life of many years can be expected of GraphiteCOVA mechanical carbon seals and counter faces.

## Leak Resistance

Impregnated sealing rings are well proven for normal working conditions. For particularly high pressure requirements we also supply gas-tight rings which are inspected for leaks.

When shrinking or pressing GraphiteCOVA carbon face seals into metal housings, the same points must be considered as for carbon bearings (see page 10). A shrink fit does not always provide sufficient guarantee of axial tightness. In such cases it is better to bond the carbon face seals into the housing.



Fig. 7 Carbon rings for sliding ring seals

Fig. 8  
The sealing principle  
of a single action  
sliding ring with  
carbon ring

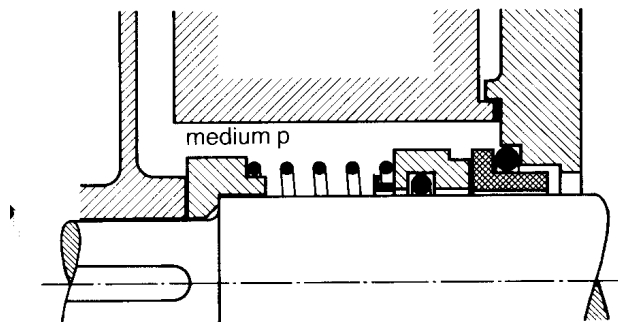

## GraphiteCOVA Steam Nozzles

Steam-heated driers and calenders in processing plants of the

- Paper Industry
- Textile Industry
- Rubber Industry
- Chemical Industry

are provided with carbon packing rings pressed laterally onto the steam inlet and outlet vents in proven designs. The single seals generally have concave or convex surfaces because this design allows the packing rings to adjust to the oscillation of calender drums.

Fig. 9 shows the installation principle of carbon sealing rings in the heating joints of calender driers. This location has the advantage that the external and internal steam supply pipes move independently and that differences in length due to temperature can be compensated.

The sliding surfaces of GraphiteCOVA carbon seals attain the surface quality necessary for sealing after only a short running-in period. Fig. 11 shows the almost polished smooth running surface of a carbon sealing lens after approx. 10,000 hours of Operation.

GraphiteCOVA produces one-piece rings of carbon and graphite for steam seals to popular designs in proven grades at economic prices.

For oil free, steam lubricated seals we recommend grade B 525; for the opposing bearings without steam lubrication we recommend grade B 520 DXT.

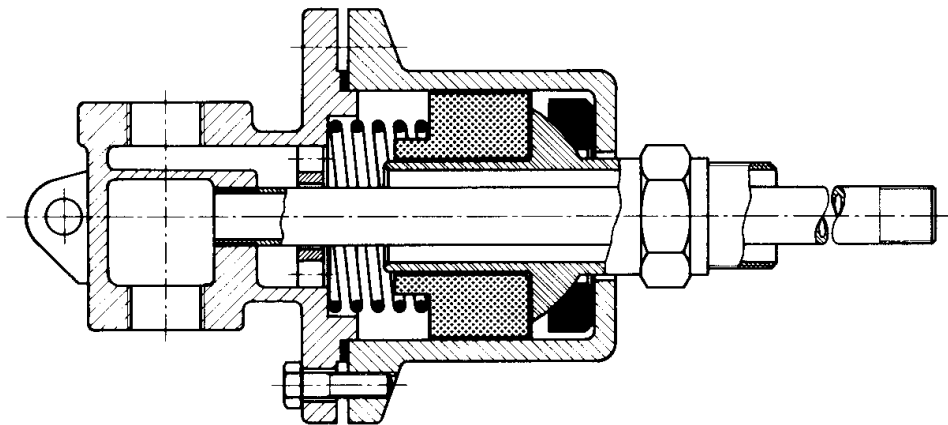

Fig. 9 Diagrammatic view of the installation of a carbon sealing ring in the heating joint of a calender drier.

Fig. 9 Diagrammatic view of the installation of a carbon sealing ring in the heating joint of a calender drier.



Fig. 10: carbon steam seals

Fig. 11: Running surface of a carbon sealing ring after 10.000 hours of operation



## GraphiteCOVA Water Turbine Carbon Gland seals

Hydroelectric Power Stations have vertical or horizontal Francis or Kaplan turbines which transfer the hydrodynamic power to 3 phase generators.

The turbine shaft is sealed with carbon rings. These are composed of several segments with free movement between the joints. To prevent these being pushed together in Operation, each segment is fixed to the casing wall. The contact pressure of the rings should lie between 1.5 ... 2.0 N/cm<sup>2</sup>.

Similar constructions are also used for large pump turbines. Graphite COVA manufacture rings of up to 30 segments with diameters of up to 4,000 mm for this field of application.

The following figure shows overlapped-tenoned carbon ring segments for shaft sealing on water turbines.



Fig. 12 Overlapped-tenoned carbon segments for shaft sealing on water turbines



## GraphiteCOVA Packing Rings

Packing rings are divided into two types, those with shaft clearance (with gaps) and those in contact with the shaft. When calculating the bore tolerances, allowance should be made for carbon and graphite having a much lower thermal expansion coefficient ( $3 \dots 5 \times 10^{-6}/K$ ) than metals.

The contact pressure of the carbon rings to the cylinder necessary to achieve a good sealing effect is attained with the use of a garter spring.

The following spring materials have proved successful in practice:

up to 300°C - normal spring steel wire

up to 350°C - V 2A wire (1.4310)

V 2A wire (1.4571) high corrosion resistance

up to 550°C - Stainless steel wire, very brittle low expandability

Wire thickness of 0.2... 1.5 mm are used. Calculation of the Spiral tension spring can be based on a maximum permissible contact pressure of the carbon ring on the cylinder of 1 ... 1.5 N/cm<sup>2</sup>. The sealing rings must be secured against torsion.



Fig. 13 Carbon rings for contact seals

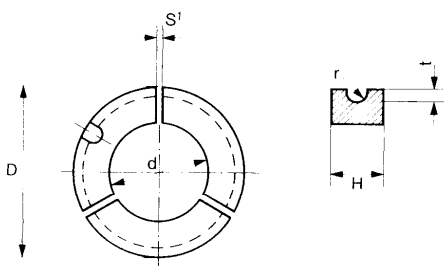

Fig. 14 Dimensioning of a ring and calculation of the garter tension spring

$r$  = working radius  
 $t$  = groove depth  
 $n$  = number of segments  
 $S$  = total gap ( $S_1 = s/n$ )  
 $D = 1.5d$   
 $H \sim 0.2d$   
 Spring external  $\varnothing \sim 0.5 H$   
 $r = \text{spring external } \varnothing / 2 + 0.5$   
 $t = \text{spring external } \varnothing / 2$

## GraphiteCOVA Contactless Seals

The use of multi-piece carbon rings is preferred for axial sealing of shafts e.g. for steam turbines. In general 4-8 carbon rings are placed one behind the other and assembled as chamber packings with the appropriate packing rings.

Fig. 15 shows the front and side views of a four piece carbon packing ring with single tenon joints.

The peripheral groove is for the insertion of the garter spring with which the ring can be radially tightened onto the shaft. After running in, an extremely narrow ring gap is present between the shaft and carbon rings. This guarantees a good sealing effect.

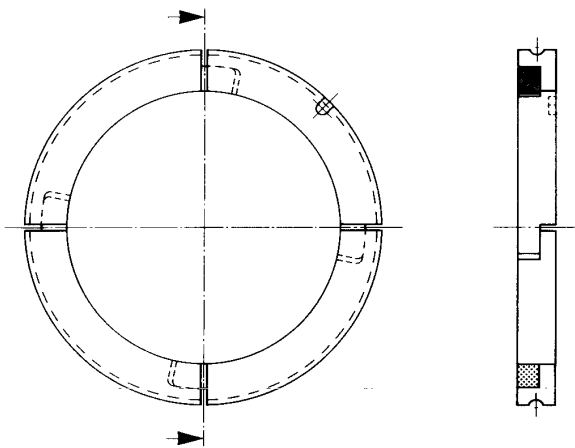
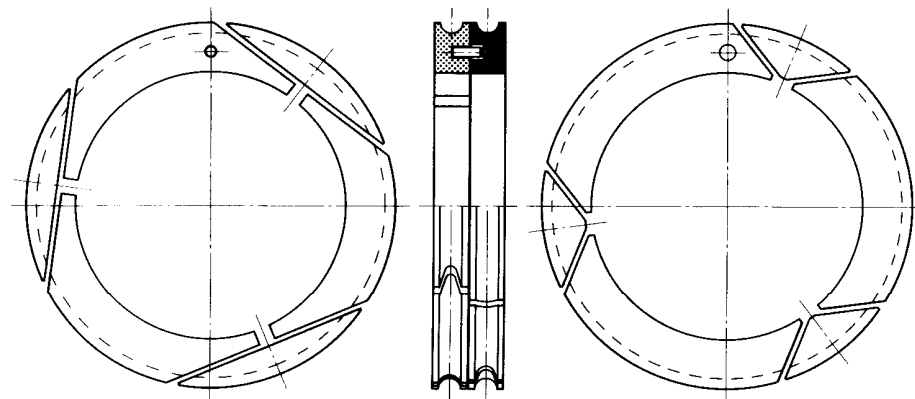

Fig. 15 Four piece carbon packing ring

In contrast to shaft clearance seals these packing rings are in permanent contact with the shaft. They are used widely for sealing reciprocating shafts.

With good design GraphiteCOVA carbon rings wear well.

In practical use this means that even in a „no-maintenance“ Operation they will have a long working life and make a very good seal with minimum space requirements.



▲ Fig. 16  
Carbon sealing rings with non-radially  
cut segment joints

# GraphiteCOVA Vanes

## GraphiteCOVA Separating Slides for Rotary Compressors and Pumps

Common applications are for handling and dosing of liquids with a low wetting capacity: the Operation of oil-free compressed air tools; air compressors for pneumatic plant, e.g. (in the case of industry) milking machines etc. Carbon has proved superior to other materials in this field thanks to its outstanding wearing and self-lubricating properties for both wet and dry Operation.

The Operation principle of the rotary compressors can be seen below in Fig. 17. The carbon separating vanes located in grooves in the eccentric rotor, divide the space between the casing and the rotor into a number of cells with varying volume. On rotation, the carbon vanes are lightly pressed against the casing wall as a result of the centrifugal force and thus function as seals. They connect the individual cells alternately with the inlet and outlet sides of the pump. Single stage compressors can be used up to approximately 3 ... 4 bar, two stage up to approximately 8 bar.

We manufacture carbon vanes in a wide range of sizes to customers. Fig. 18 illustrates our normal manufacturing Standards for tolerances and surface finish. In addition GraphiteCOVA produce end plates in carbon as a counterface for the vanes in this type of pump. Our manufacturing Programme in this area also includes carbon vanes as regulators for reciprocating actions e.g. to open and dose valves. The counterface surface finish is a decisive factor for the durability of the carbon material.

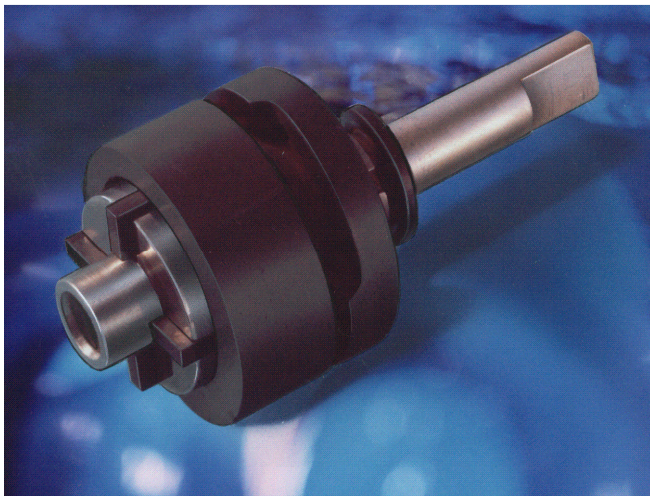

Fig. 17 Rotor Housing and Vanes of a Rotary Compressor

For this reason the cylinder surfaces of rotary compressors should also be finely ground or honed. Surface roughnesses of  $S_r > 2 \mu\text{m}$  are to be avoided.

In addition to carbon itself the following metals may be considered for the opposing materials to the rotating carbon components:

- rust and acid resistant steels
- hard chrome plated running surfaces
- rust proof or heat resistant cast steel
- high temper unalloyed grey cast iron
- cast iron with nodular graphite structure (e.g. Meehanite)
- manganese bronze or phosphor bronze

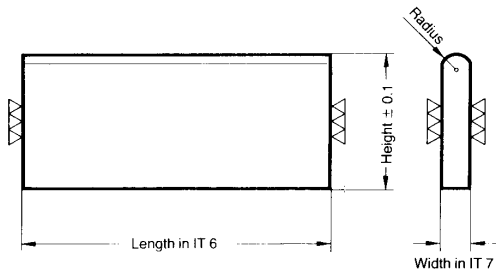

Fig. 18  
tolerance data for carbon separating slides

## GraphiteCOVA Sealing Strips

Carbon or graphite sealing elements can be used for many purposes in the mechanical plant of the paper and pulp industries: suction rolls of paper machines for example are furnished with carbon sealing strips. High operating times can be achieved with these special machines because of the low friction factor and the resulting low wear rate of the strips.

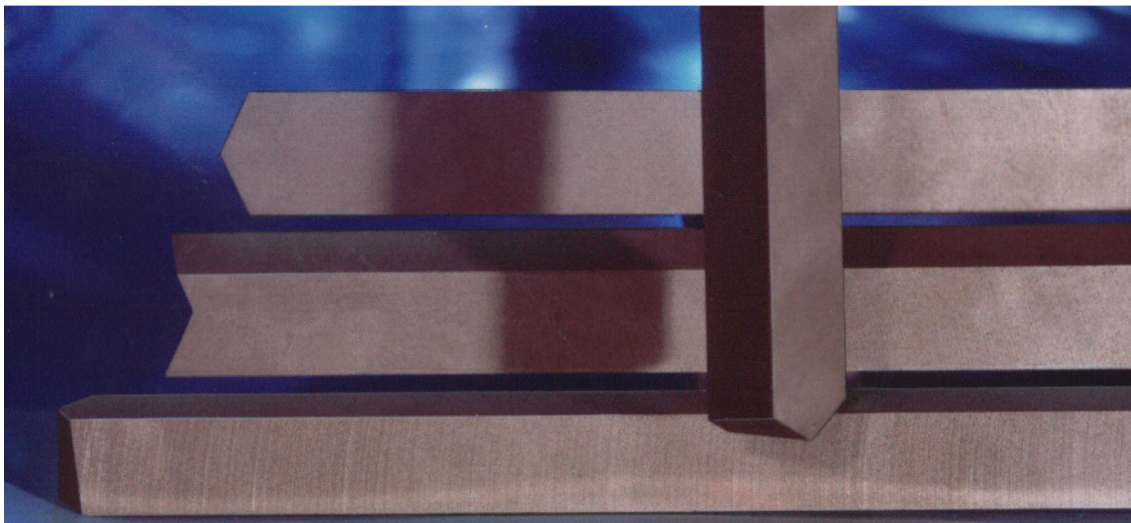

Fig. 19 Carbon sealing strips for suction rolls in paper machines

## GraphiteCOVA Stripping Components

Carbon stripping elements are mainly used in the textile and food industries. The components are used in dyeing equipment in textile machines, for example to remove the dye from printing calenders. Design Engineers are able to take advantage of the high corrosion resistance of carbon and graphite and of their resistance to many aggressive chemical media.

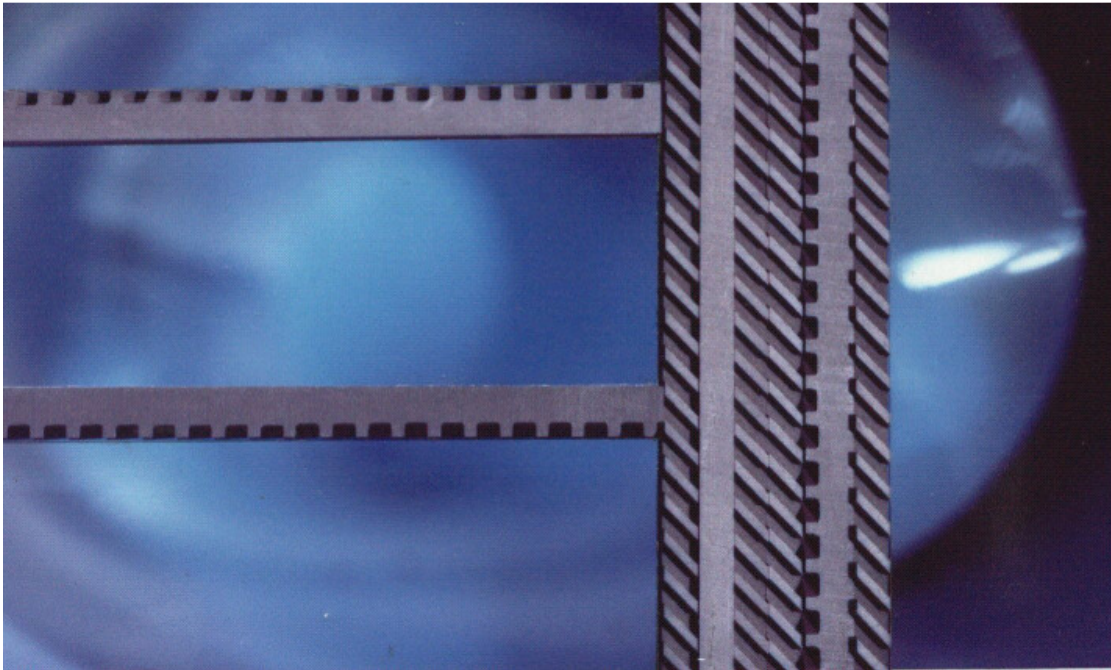

Fig. 20 Graphite stripping elements

## GraphiteCOVA Materials for Bearings and Sealings

Application	Carbon and Graphite Grades			
	B 497 XN B 513 XN B 527 XN	B 520 DXT	B 521	B 525
Bearings	<b>X</b>	<b>X</b>	<b>X</b>	
Guide Rings	<b>X</b>	<b>X</b>		
Piston Rings	<b>X</b>	<b>X</b>		
Sliding Ring Seals		<b>X</b>		
Steam Seals		<b>X</b>		<b>X</b>
Water Turbine Rings		<b>X</b>		<b>X</b>
Pump Turbine Rings		<b>X</b>		<b>X</b>
Contactless Seals		<b>X</b>		<b>X</b>
Contact Seals		<b>X</b>	<b>X</b>	
Separating Slides	<b>X</b>	<b>X</b>		
Carbon Vanes	<b>X</b>	<b>X</b>		<b>X</b>
Stripping Components	<b>X</b>	<b>X</b>		