

Cam Units DHC
Schieber DHC
Unità a Camme DHC



OMCR[®]
STANDARD DIE COMPONENTS

2018.01



OMCR CODE	Work Angle β	Slider Width (mm)	Closed Cam Height (mm)	Work Area W x H (mm)	Max Work Force with shoulder 10 ⁶ cycles (kN)	Extraction Force (kN)		Page number		
						E _F				
						Fs	Spring	Gas Spring		
DHC052	0°	52	140	52x65	38	0,62÷0,65	-	888		
DHC065	0÷20°	65	160 (00.40÷05.45 / 10.45) 170 (05.70 / 10.70÷20.70)	65x70	44÷48	0,78÷1,02	-	892		
DHC100	0÷20°	100	200	100x100	75÷82	-	4,6÷6,1	896		
DHC150	0÷20°	150	220 (00.40÷15.45 / 20.45) 230 (15.70 / 20.70)	150x100	120÷127	-	4,6÷6,6	900		
DHC200	0°	200	240	200x110	176	-	8,6÷10,1	904		
DHC250	0°	250	270	250x130	232	-	8,6÷9,4	908		
DHC300	0°	300	270	300x130	272	-	8,6÷9,4	912		
DHC400	0°	400	250	400x150	480	-	25,2	916		

Cam Units DHC



Optimized logistics for top service



DIE MOUNTED CAM UNIT - HORIZONTALSCHIEBER - UNITÀ A CAMME A BASE STAMPO

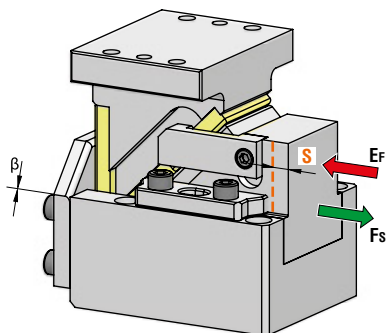

OMCR CODE	Work Angle	Stroke (mm)	Max Work Force with shoulder (kN)	Extraction Force (kN)
	β	S	Fs	Ef Spring
DHC052.00.25	0°	25	38	0,62
DHC052.00.40	0°	40	38	0,63
DHC052.00.60	0°	60	38	0,65



P.605

STOCK	ORDER EXAMPLE	Art.	Work Angle = 0°	Stroke = 40
		DHC052	00	40

OMCR CODE	Work Angle	Stroke (mm)	Overall Dimensions (mm)						
	β	S	A	B	C	D	E	F	G
DHC052.00.25	0°	25	120	120	80	70	40	40	80
DHC052.00.40	0°	40	135	135	95	80	50	45	90
DHC052.00.60	0°	60	180	180	140	55	70	55	110



DIE MOUNTED CAM UNIT - HORIZONTALSCHIEBER - UNITÀ A CAMME A BASE STAMPO

X VIEW

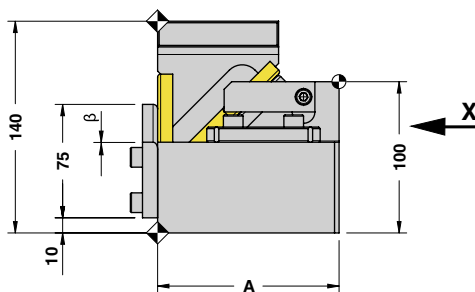
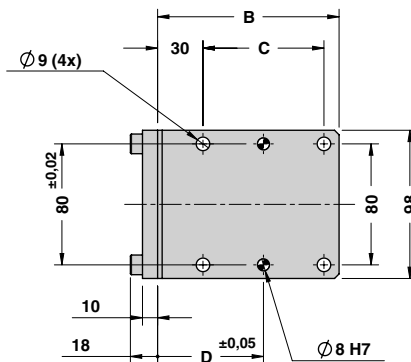
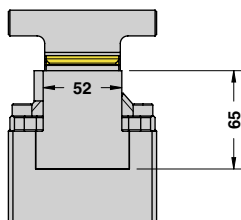

CAM DIAGRAM

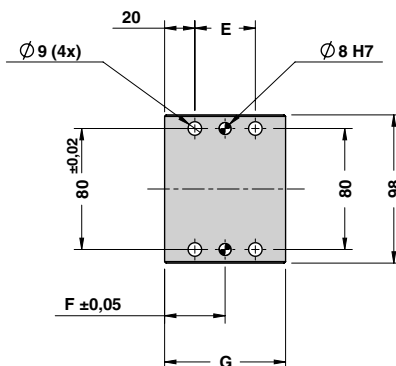
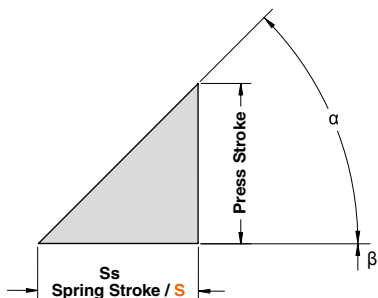

Work Angle	Inner Angle	Slider Work Stroke (mm)	Press Stroke (mm)	Spring Stroke (mm)
β	α	S	Ps	Ss
0°	45°	25	25	25
0°	45°	40	40	40
0°	45°	60	60	60

Cam Units DHC



DIE MOUNTED CAM UNIT - HORIZONTALSCHIEBER - UNITÀ A CAMME A BASE STAMPO

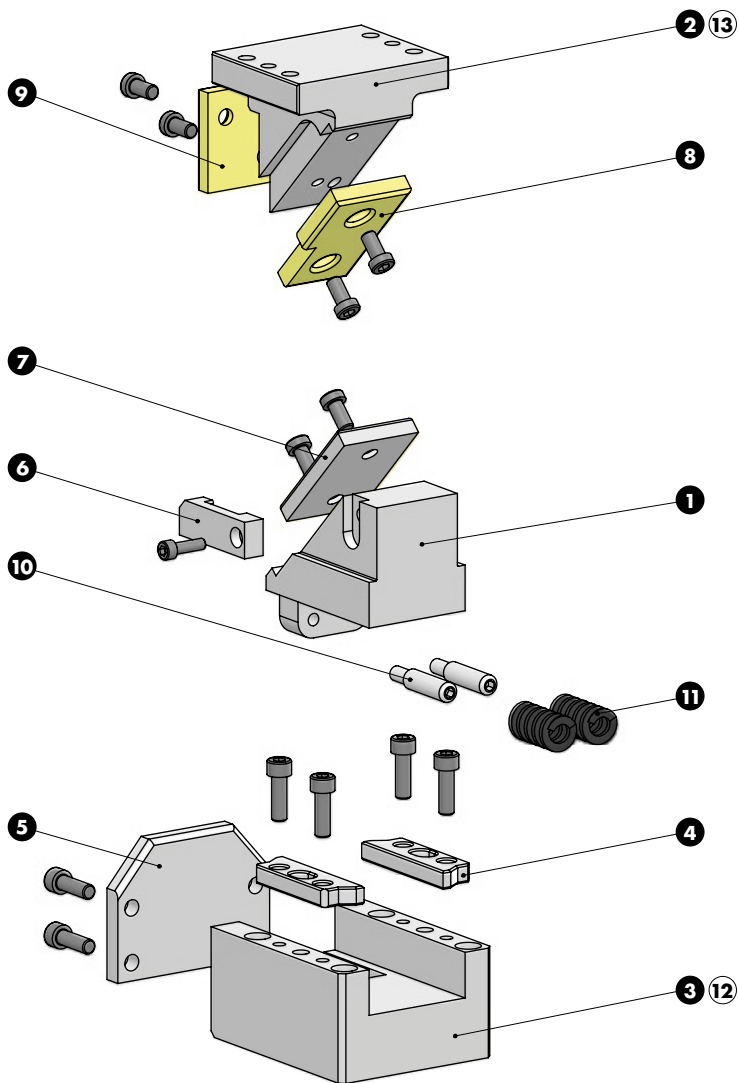



DIE MOUNTED CAM UNIT - HORIZONTALSCHIEBER - UNITÀ A CAMME A BASE STAMPO

SLIDER STRUCTURE, POSITIVE RETURN STRUCTURE AND CLEARANCES

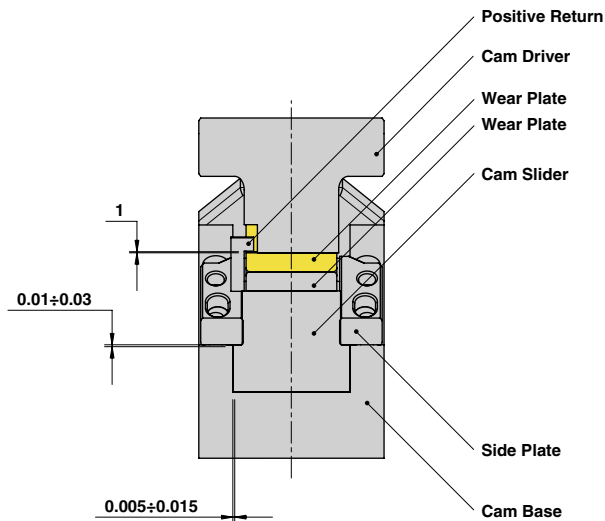

PART LIST

Particular number	Description	Material	Quantity
1	Cam Slider	GGG-50 + Graphite	1
2	Cam Driver	GG-25	1
3	Cam Base	GG-25	1
4	Side Plate	CK45	2
5	Stopper Plate	CK45	1
6	Positive Return	CK45	1
7	Wear Plate	CK45	1
8	Wear Plate	CuZn25Al5 + Graphite - HB > 190	1
9	Wear Plate	CuZn25Al5 + Graphite - HB > 190	1
10	Spring Guide Pin	CK45	2
11	Spring	-	2
12	Cam Base Fixing Screws M8x50 DIN 912	-	4
13	Cam Driver Fixing Screws M8x30 DIN 912	-	4



DIE MOUNTED CAM UNIT - HORIZONTALSCHIEBER - UNITÀ A CAMME A BASE STAMPO

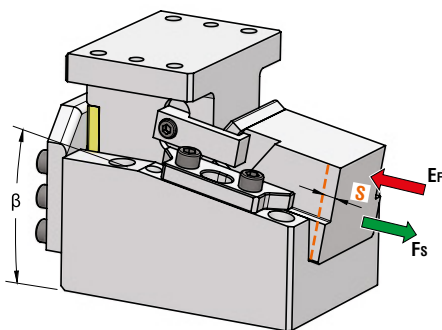

P.605

OMCR CODE	Work Angle	Stroke (mm)	Max Work Force with shoulder (kN)	Extraction Force (kN)
	β	S	F _s	E _f Spring
DHC065.00.40	0°	40	44	0,79
DHC065.00.60	0°	60	44	0,80
DHC065.05.45	5°	45	48	0,78
DHC065.05.70	5°	70	48	1,02
DHC065.10.45	10°	45	48	0,78
DHC065.10.70	10°	70	48	1,02
DHC065.15.45	15°	45	48	0,78
DHC065.15.70	15°	70	48	1,02
DHC065.20.45	20°	45	48	0,78
DHC065.20.70	20°	70	48	1,02

STOCK	ORDER EXAMPLE	Art.	Work Angle = 0°	Stroke = 60
		DHC065	00	60

OMCR CODE	Work Angle	Stroke (mm)	Overall Dimensions (mm)															
	β	S	A	B	C	D	E	F	G	H	I	J	K	L	M	N	O	
DHC065.00.40	0°	40	140	115	25	80	160	145	30	100	12	27	80	130	60	50	100	
DHC065.00.60	0°	60	190	115	25	80	160	180	40	125	12	22	105	130	70	55	110	
DHC065.05.45	5°	45	150,55	112,10	12,5	100	160	145	30	100	15	25	80	120	60	50	100	
DHC065.05.70	5°	70	195,38	123,17	25	100	170	180	40	125	15	25	65	120	60	50	100	
DHC065.10.45	10°	45	154,95	108,76	20	100	160	145	30	100	15	25	79	120	60	50	100	
DHC065.10.70	10°	70	199,27	110,94	25	100	170	180	40	125	15	25	65	120	60	50	100	
DHC065.15.45	15°	45	158,18	105,09	25	100	170	145	30	100	15	25	80	120	60	50	100	
DHC065.15.70	15°	70	201,64	103,44	40	100	170	180	40	125	15	25	65	120	70	55	110	
DHC065.20.45	20°	45	160,20	101,19	30	100	170	145	30	100	15	25	80	120	60	50	100	
DHC065.20.70	20°	70	202,48	95,79	40	100	170	180	40	125	15	25	65	120	70	55	110	



DIE MOUNTED CAM UNIT - HORIZONTALSCHIEBER - UNITÀ A CAMME A BASE STAMPO

X VIEW

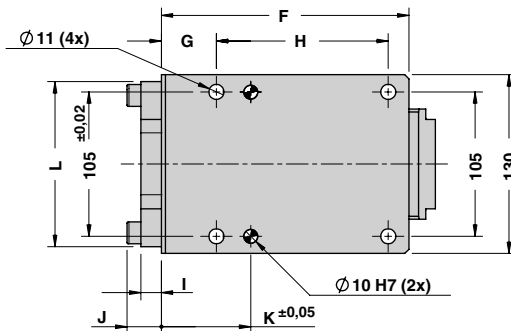
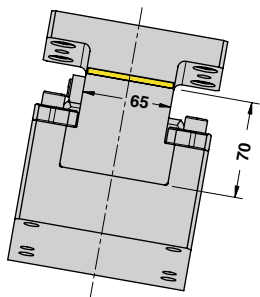

CAM DIAGRAM

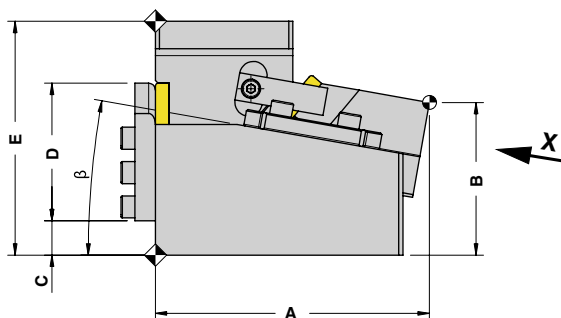
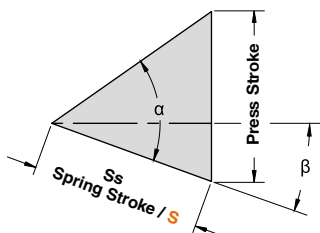

Cam Units DHC

Work Angle	Inner Angle	Slider Work Stroke (mm)	Press Stroke (mm)	Spring Stroke (mm)
β	α	S	Ps	Ss
0°	45°	40	40	40
0°	45°	60	60	60
5°	60°	45	67.94	45
5°	60°	70	105.69	70
10°	60°	45	60.63	45
10°	60°	70	94.31	70
15°	60°	45	55.11	45
15°	60°	70	85.73	70
20°	60°	45	50.87	45
20°	60°	70	79.14	70

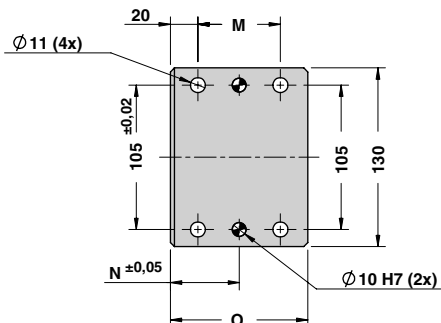



DIE MOUNTED CAM UNIT - HORIZONTALSCHIEBER - UNITÀ A CAMME A BASE STAMPO

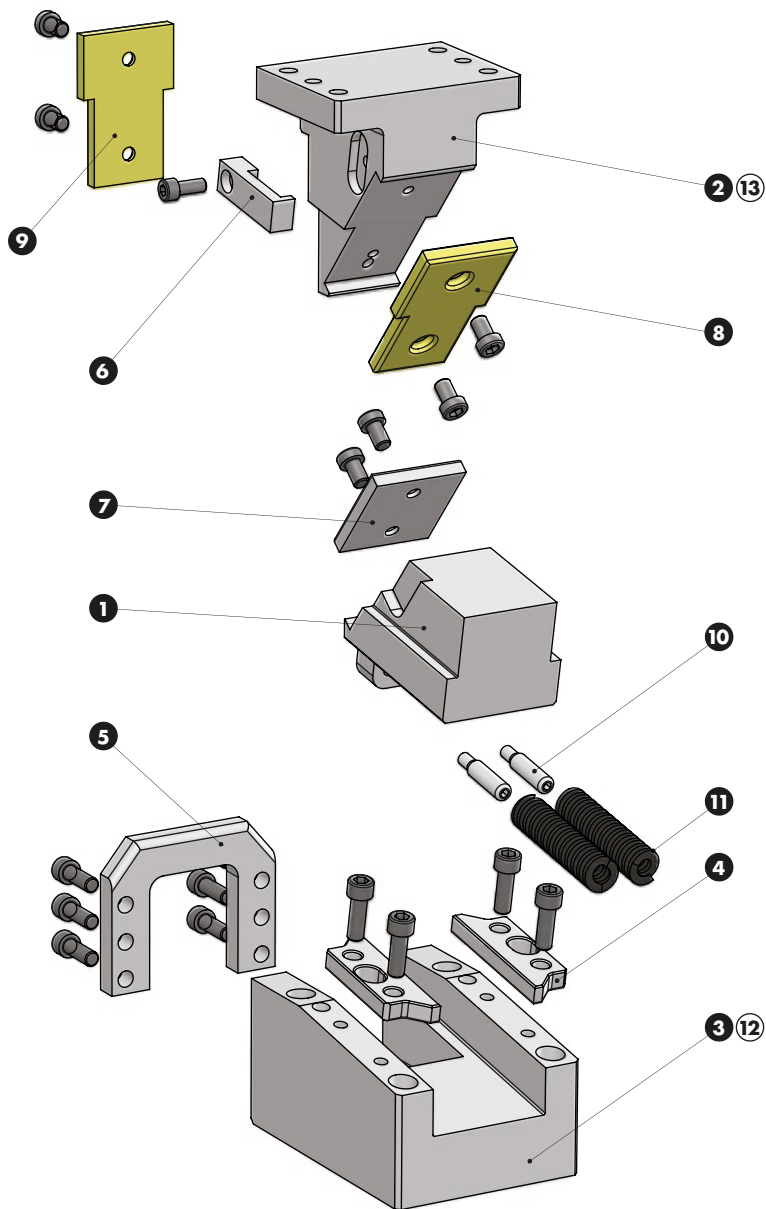



DIE MOUNTED CAM UNIT - HORIZONTALSCHIEBER - UNITÀ A CAMME A BASE STAMPO

SLIDER STRUCTURE, POSITIVE RETURN STRUCTURE AND CLEARANCES

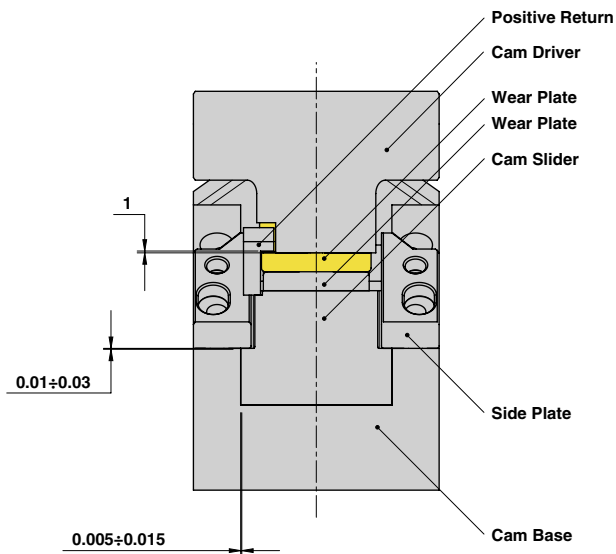

PART LIST

Particular number	Description	Material	Quantity
1	Cam Slider	GGG-50 + Graphite	1
2	Cam Driver	GG-25	1
3	Cam Base	GG-25	1
4	Side Plate	CK45	2
5	Stopper Plate	CK45	1
6	Positive Return	CK45	1
7	Wear Plate	CK45	1
8	Wear Plate	CuZn25Al5 + Graphite - HB > 190	1
9	Wear Plate	CuZn25Al5 + Graphite - HB > 190	1
10	Spring Guide Pin	CK45	2
11	Spring	-	2
12	Cam Base Fixing Screws M10x50 DIN 912	-	4
13	Cam Driver Fixing Screws M10x40 DIN 912	-	4



DIE MOUNTED CAM UNIT - HORIZONTALSCHIEBER - UNITÀ A CAMME A BASE STAMPO

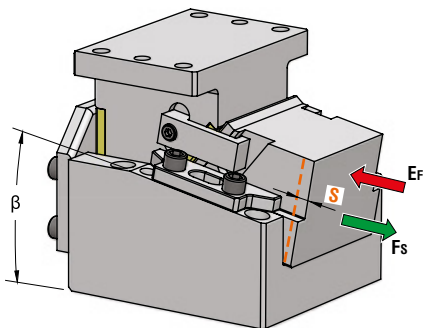

P.605

OMCR CODE	Work Angle	Stroke (mm)	Max Work Force with shoulder (kN)	Extraction Force (kN)
	β	S	F _s	E _f Gas Spring
DHC100.00.40	0°	40	75	4,6
DHC100.00.60	0°	60	75	5,9
DHC100.00.80	0°	80	75	6,8
DHC100.05.45	5°	45	82	4,6
DHC100.05.70	5°	70	82	6,1
DHC100.10.45	10°	45	82	4,6
DHC100.10.70	10°	70	82	6,1
DHC100.15.45	15°	45	82	4,6
DHC100.15.70	15°	70	82	6,1
DHC100.20.45	20°	45	82	4,6
DHC100.20.70	20°	70	82	6,1

STOCK	ORDER EXAMPLE	Art.	Work Angle = 0°	Stroke = 60
		DHC100	00	60

OMCR CODE	Work Angle	Stroke (mm)	Overall Dimensions (mm)															
	β	S	A	B	C	D	E	F	G	H	I	J	K	L	M	N	O	P
DHC100.00.40	0°	40	190	150	30	90	190	45	130	140	16	28	105	170	80	60	120	100
DHC100.00.60	0°	60	210	150	30	90	190	45	130	140	16	28	105	170	100	70	140	100
DHC100.00.80	0°	80	250	150	10	115	220	45	160	140	15	27	135	165	110	75	150	100
DHC100.05.45	5°	45	172,22	145,28	27,5	115	160	40	105	140	15	27	90	165	60	50	100	90
DHC100.05.70	5°	70	207,08	147,23	30	115	190	45	130	150	15	27	70	165	80	60	120	90
DHC100.10.45	10°	45	178,12	134,98	30	115	160	40	105	140	15	27	90	165	60	50	100	90
DHC100.10.70	10°	70	212,59	133,90	30	115	190	45	130	150	15	27	70	165	80	60	120	90
DHC100.15.45	15°	45	182,67	129,23	32,5	115	160	40	105	140	15	27	90	165	70	55	110	90
DHC100.15.70	15°	70	216,48	130,17	35	115	190	45	130	150	15	27	70	165	90	65	130	90
DHC100.20.45	20°	45	185,83	118,14	35	115	160	40	105	140	15	27	90	165	70	55	110	90
DHC100.20.70	20°	70	218,72	121,17	45	115	190	45	130	150	15	27	70	165	90	65	130	90





DIE MOUNTED CAM UNIT - HORIZONTALSCHIEBER - UNITÀ A CAMME A BASE STAMPO

X VIEW

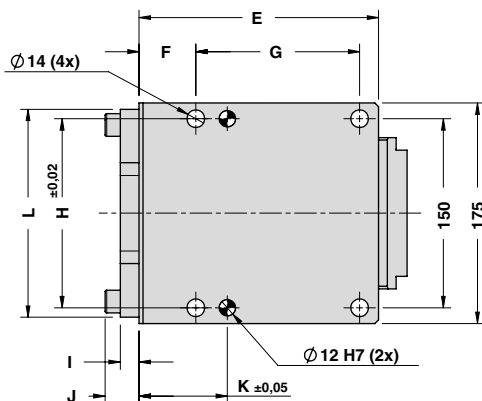
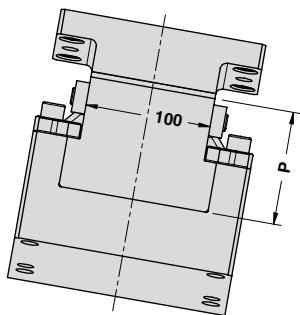

CAM DIAGRAM

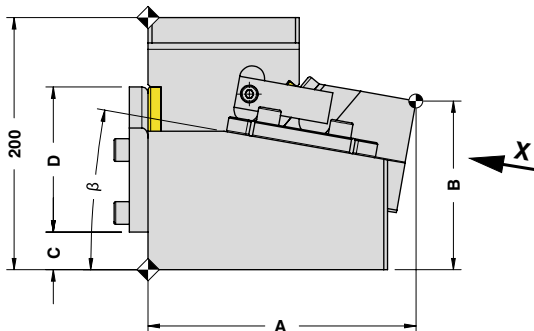
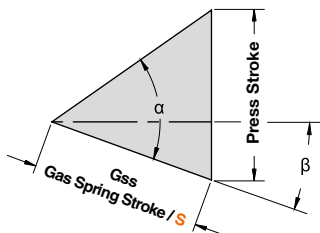

Work Angle	Inner Angle	Slider Work Stroke (mm)	Press Stroke (mm)	Gas Spring Stroke (mm)
β	α	S	Ps	Gss
0°	45°	40	40	40
0°	45°	60	60	60
0°	45°	80	80	80
5°	60°	45	67,94	45
5°	60°	70	105,69	70
10°	60°	45	60,63	45
10°	60°	70	94,31	70
15°	60°	45	55,11	45
15°	60°	70	85,73	70
20°	60°	45	50,87	45
20°	60°	70	79,14	70

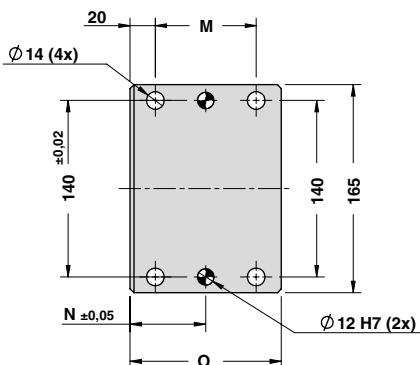



DIE MOUNTED CAM UNIT - HORIZONTALSCHIEBER - UNITÀ A CAMME A BASE STAMPO

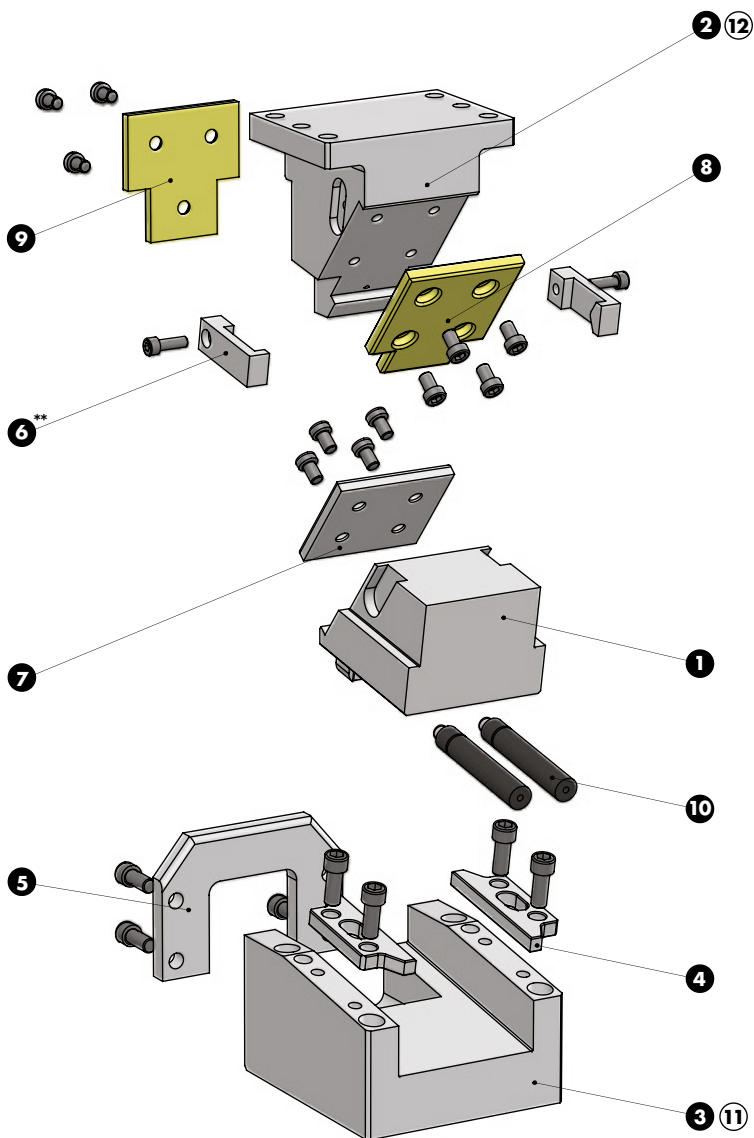

** Only nr.1 positive return for DHC100.00.
 DHC100.00 mit nur einer Zwangsrückholung.
 Solo un gancio di sicurezza per le DHC100.00.



DIE MOUNTED CAM UNIT - HORIZONTALSCHIEBER - UNITÀ A CAMME A BASE STAMPO

SLIDER STRUCTURE, POSITIVE RETURN STRUCTURE AND CLEARANCES

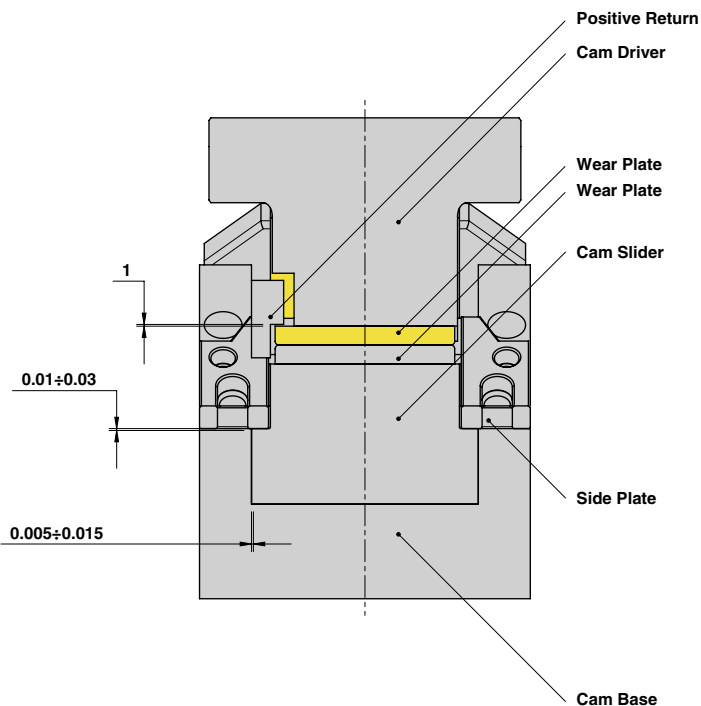

PART LIST

Particular number	Description	Material	Quantity
1	Cam Slider	GGG-50 + Graphite	1
2	Cam Driver	GG-25	1
3	Cam Base	GG-25	1
4	Side Plate	CK45	2
5	Stopper Plate	CK45	1
6	Positive Return	CK45	1
7	Wear Plate	CK45	1
8	Wear Plate	CuZn25Al5 + Graphite - HB > 190	1
9	Wear Plate	CuZn25Al5 + Graphite - HB > 190	1
10	Gas Spring	-	2
11	Cam Base Fixing Screws M12x60 DIN 912	-	4
12	Cam Driver Fixing Screws M12x45 DIN 912	-	4



DIE MOUNTED CAM UNIT - HORIZONTALSCHIEBER - UNITÀ A CAMME A BASE STAMPO

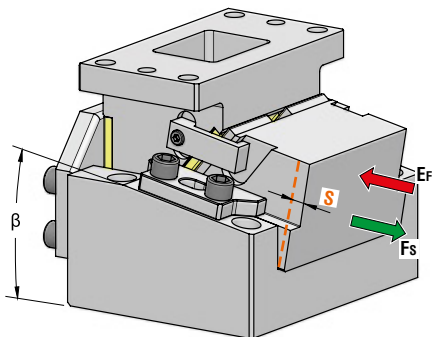

P.605

OMCR CODE	Work Angle	Stroke (mm)	Max Work Force with shoulder (kN)	Extraction Force (kN)
	β	S	F _s	E _f Gas Spring
DHC150.00.40	0°	40	120	5,7
DHC150.00.60	0°	60	127	5,9
DHC150.05.45	5°	45	127	4,6
DHC150.05.70	5°	70	127	6,6
DHC150.10.45	10°	45	127	4,6
DHC150.10.70	10°	70	127	6,6
DHC150.15.45	15°	45	127	4,6
DHC150.15.70	15°	70	127	6,6
DHC150.20.45	20°	45	127	4,6
DHC150.20.70	20°	70	127	6,6

STOCK	ORDER EXAMPLE	Art.	Work Angle = 0°	Stroke = 60
		DHC150	00	60

OMCR CODE	Work Angle	Stroke (mm)	Overall Dimensions (mm)													
	β	S	A	B	C	D	E	F	G	H	I	J	K	L	M	N
DHC150.00.40	0°	40	190	170	45	100	220	190	125	19	35	105	250	80	60	120
DHC150.00.60	0°	60	210	170	45	100	220	200	135	19	35	110	250	100	70	140
DHC150.05.45	5°	45	193,01	158,50	30	125	220	190	125	20	36	105	240	70	55	110
DHC150.05.70	5°	70	217,92	166,32	40	125	220	200	135	20	36	120	240	90	65	130
DHC150.10.45	10°	45	199,55	151,36	40	125	220	190	125	20	36	105	240	70	55	110
DHC150.10.70	10°	70	224,17	152,02	40	125	220	200	135	20	36	120	240	90	65	130
DHC150.15.45	15°	45	204,58	143,71	40	125	220	190	125	20	36	105	240	80	60	120
DHC150.15.70	15°	70	228,73	152,24	55	125	230	200	135	20	36	120	240	100	70	140
DHC150.20.45	20°	45	208,05	135,70	40	125	220	190	125	20	36	105	240	80	60	120
DHC150.20.70	20°	70	231,54	137,15	55	125	230	200	135	20	36	120	240	100	70	140



DIE MOUNTED CAM UNIT - HORIZONTALSCHIEBER - UNITÀ A CAMME A BASE STAMPO

X VIEW

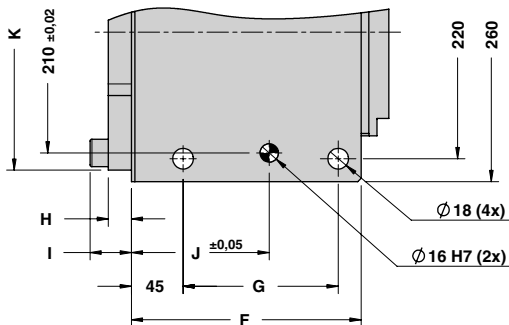
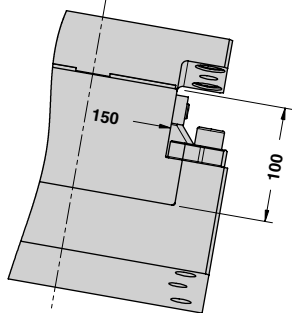

CAM DIAGRAM

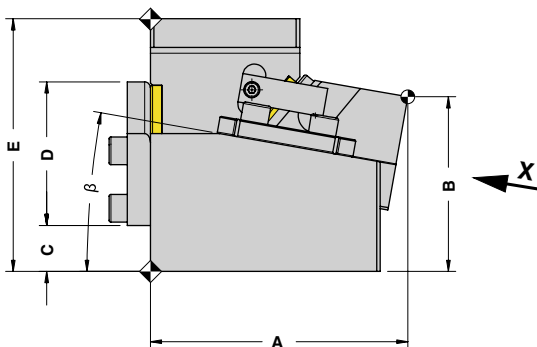
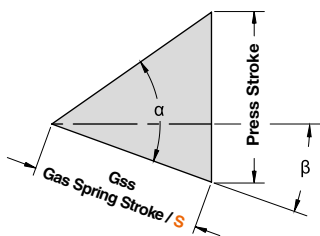

Cam Units DHC

Work Angle	Inner Angle	Slider Work Stroke (mm)	Press Stroke (mm)	Gas Spring Stroke (mm)
β	α	S	Ps	Gss
0°	45°	40	40	40
0°	45°	60	60	60
5°	60°	45	67.94	45
5°	60°	70	105.69	70
10°	60°	45	60.63	45
10°	60°	70	94.31	70
15°	60°	45	55.11	45
15°	60°	70	85.73	70
20°	60°	45	50.87	45
20°	60°	70	79.14	70

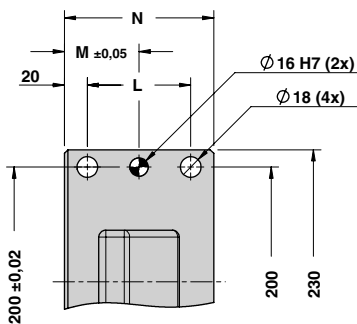



DIE MOUNTED CAM UNIT - HORIZONTALSCHIEBER - UNITÀ A CAMME A BASE STAMPO

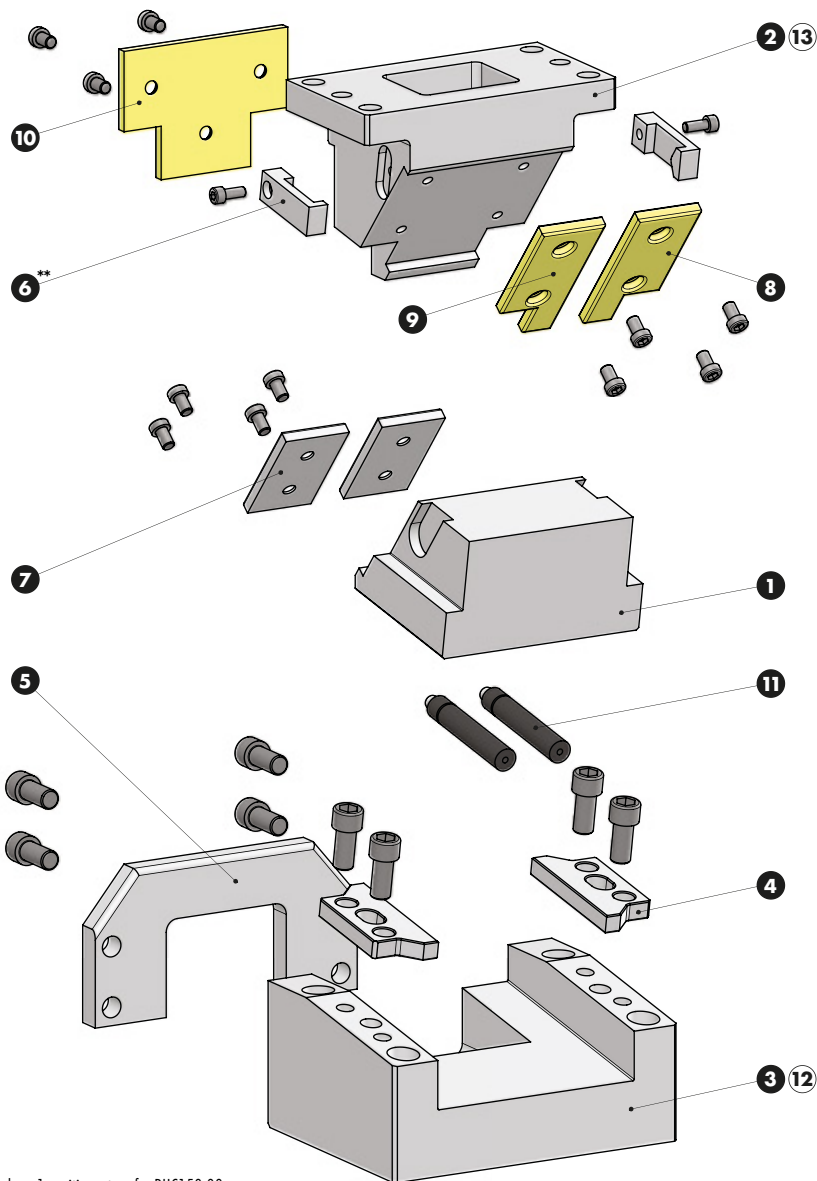

** Only nr.1 positive return for DHC150.00.
 DHC150.00 mit nur einer Zwangsrückholung.
 Solo un gancio di sicurezza per le DHC150.00.



DIE MOUNTED CAM UNIT - HORIZONTALSCHIEBER - UNITÀ A CAMME A BASE STAMPO

SLIDER STRUCTURE, POSITIVE RETURN STRUCTURE AND CLEARANCES

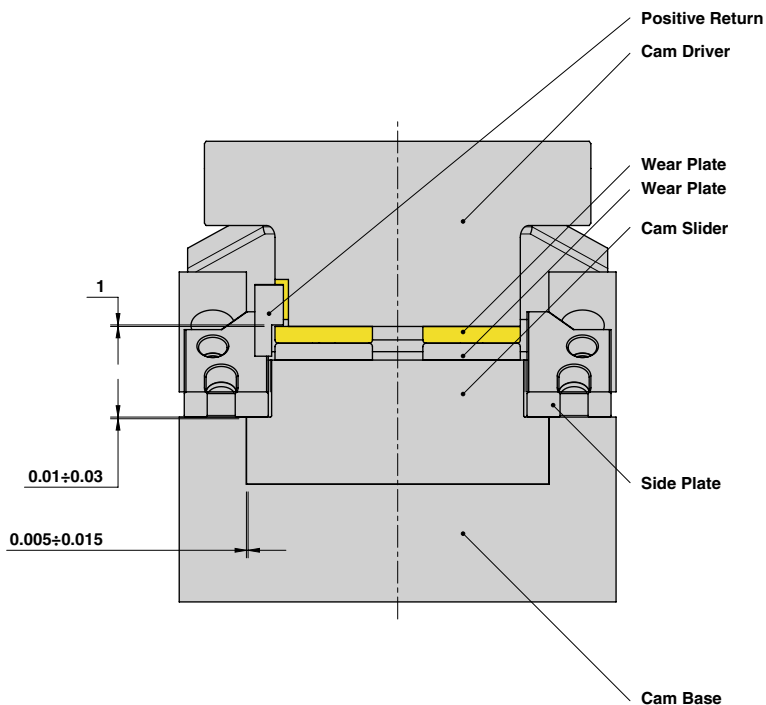

PART LIST

Particular number	Description	Material	Quantity
1	Cam Slider	GGG-50 + Graphite	1
2	Cam Driver	GG-25	1
3	Cam Base	GG-25	1
4	Side Plate	CK45	2
5	Stopper Plate	CK45	1
6	Positive Return	CK45	2
7	Wear Plate	CK45	1
8	Wear Plate	CuZn25Al5 + Graphite - HB > 190	1
9	Wear Plate	CuZn25Al5 + Graphite - HB > 190	1
10	Wear Plate	CuZn25Al5 + Graphite - HB > 190	2
11	Gas Spring	-	2
12	Cam Base Fixing Screws M16x80 DIN 912	-	4
13	Cam Driver Fixing Screws M16x55 DIN 912	-	4



DIE MOUNTED CAM UNIT - HORIZONTALSCHIEBER - UNITÀ A CAMME A BASE STAMPO

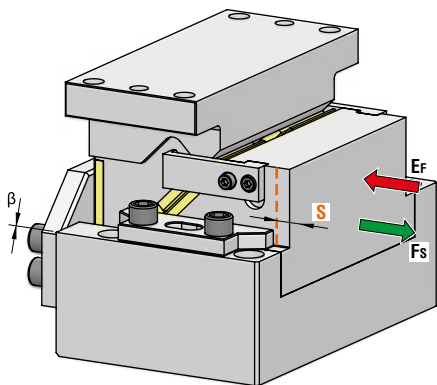

P.605

OMCR CODE	Work Angle	Stroke (mm)	Max Work Force with shoulder (kN)	Extraction Force (kN)
	β	S	F _s	E _f Gas Spring
DHC200.00.40	0°	40	176	8,6
DHC200.00.60	0°	60	176	10,1

STOCK	ORDER EXAMPLE	Art.	Work Angle = 0°	Stroke = 60
		DHC200	00	60

OMCR CODE	Work Angle	Stroke (mm)	Overall Dimensions (mm)						
	β	S	A	B	C	D	E	F	G
DHC200.00.40	0°	40	200	200	135	110	90	65	130
DHC200.00.60	0°	60	220	210	145	120	110	75	150



DIE MOUNTED CAM UNIT - HORIZONTALSCHIEBER - UNITÀ A CAMME A BASE STAMPO

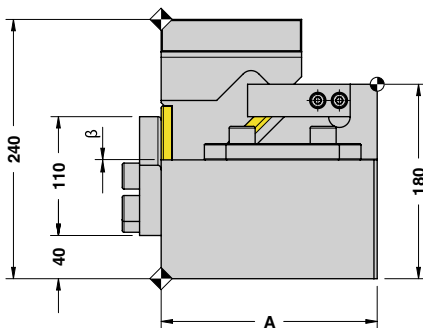
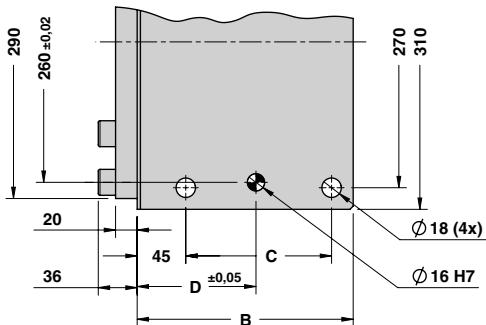
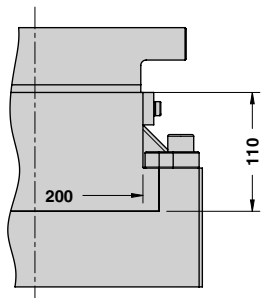

CAM DIAGRAM

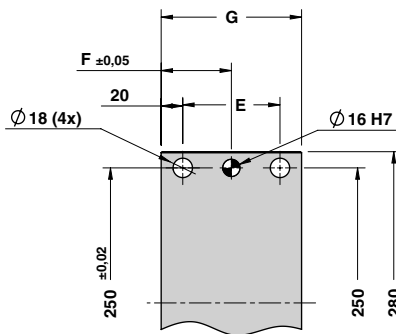
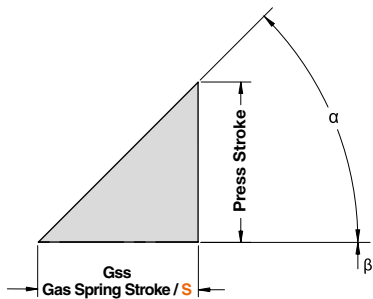

Work Angle	Inner Angle	Slider Work Stroke (mm)	Press Stroke (mm)	Gas Spring Stroke (mm)
β	α	S	Ps	Gss
0°	45°	25	25	25
0°	45°	40	40	40

Cam Units DHC



DIE MOUNTED CAM UNIT - HORIZONTALSCHIEBER - UNITÀ A CAMME A BASE STAMPO

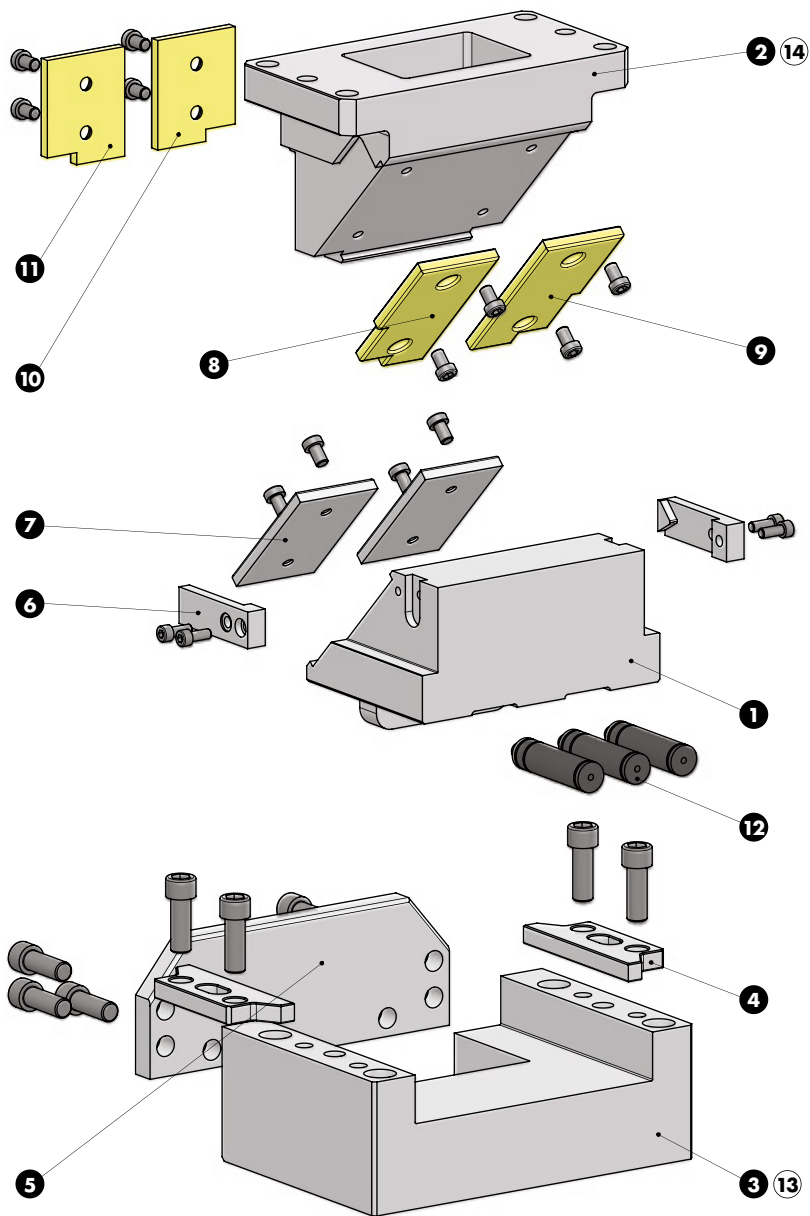



DIE MOUNTED CAM UNIT - HORIZONTALSCHIEBER - UNITÀ A CAMME A BASE STAMPO

SLIDER STRUCTURE, POSITIVE RETURN STRUCTURE AND CLEARANCES

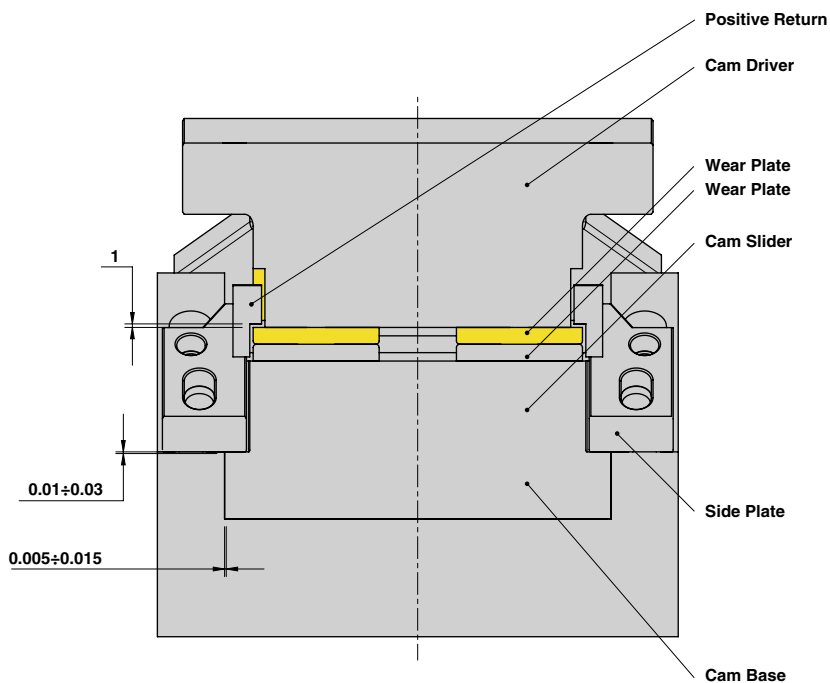

PART LIST

Particular number	Description	Material	Quantity
1	Cam Slider	GGG-50 + Graphite	1
2	Cam Driver	GG-25	1
3	Cam Base	GG-25	1
4	Side Plate	CK45	2
5	Stopper Plate	CK45	1
6	Positive Return	CK45	2
7	Wear Plate	CK45	2
8	Wear Plate	CuZn25Al5 + Graphite - HB > 190	1
9	Wear Plate	CuZn25Al5 + Graphite - HB > 190	1
10	Wear Plate	CuZn25Al5 + Graphite - HB > 190	1
11	Wear Plate	CuZn25Al5 + Graphite - HB > 190	1
12	Gas Spring	-	3
13	Cam Base Fixing Screws M16x80 DIN 912	-	4
14	Cam Driver Fixing Screws M16x60 DIN 912	-	4



DIE MOUNTED CAM UNIT - HORIZONTALSCHIEBER - UNITÀ A CAMME A BASE STAMPO

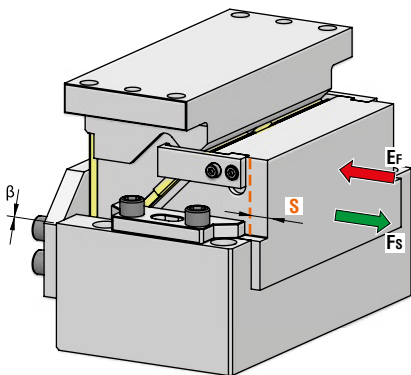

P.605

OMCR CODE	Work Angle	Stroke (mm)	Max Work Force with shoulder (kN)	Extraction Force (kN)
	β	S	F _s	E _f Gas Spring
DHC250.00.40	0°	40	232	8,6
DHC250.00.60	0°	60	232	9,4

STOCK	ORDER EXAMPLE	Art.	Work Angle = 0°	Stroke = 60
		DHC250	00	60

OMCR CODE	Work Angle	Stroke	Overall Dimensions (mm)						
	β	S	A	B	C	D	E	F	G
DHC250.00.40	0°	40	210	200	135	105	100	70	140
DHC250.00.60	0°	60	230	220	155	125	120	80	160



DIE MOUNTED CAM UNIT - HORIZONTALSCHIEBER - UNITÀ A CAMME A BASE STAMPO

X VIEW

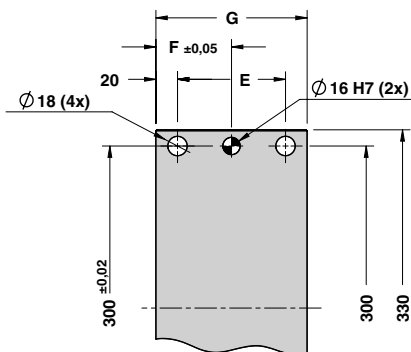
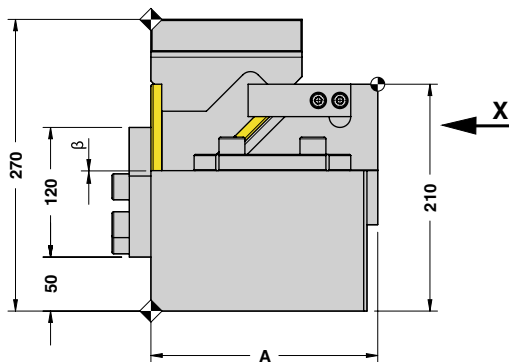
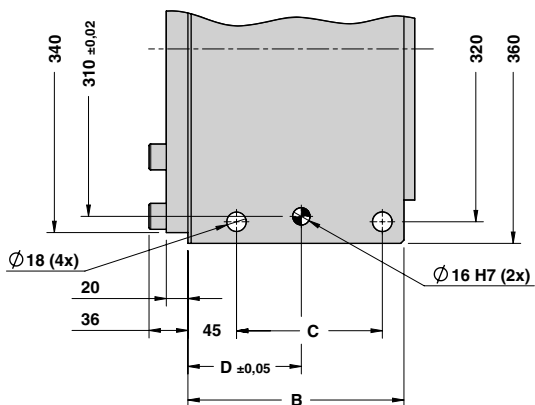
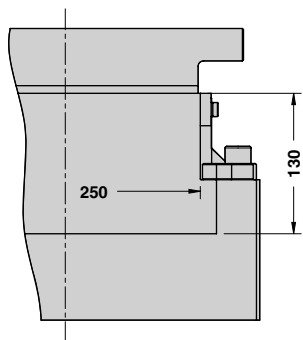

CAM DIAGRAM

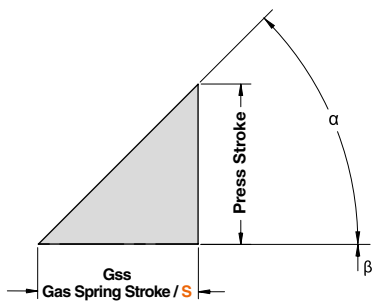

Work Angle	Inner Angle	Slider Work Stroke (mm)	Press Stroke (mm)	Gas Spring Stroke (mm)
β	α	S	Ps	Gss
0°	45°	40	40	40
0°	45°	60	60	60

Cam Units DHC



DIE MOUNTED CAM UNIT - HORIZONTALSCHIEBER - UNITÀ A CAMME A BASE STAMPO

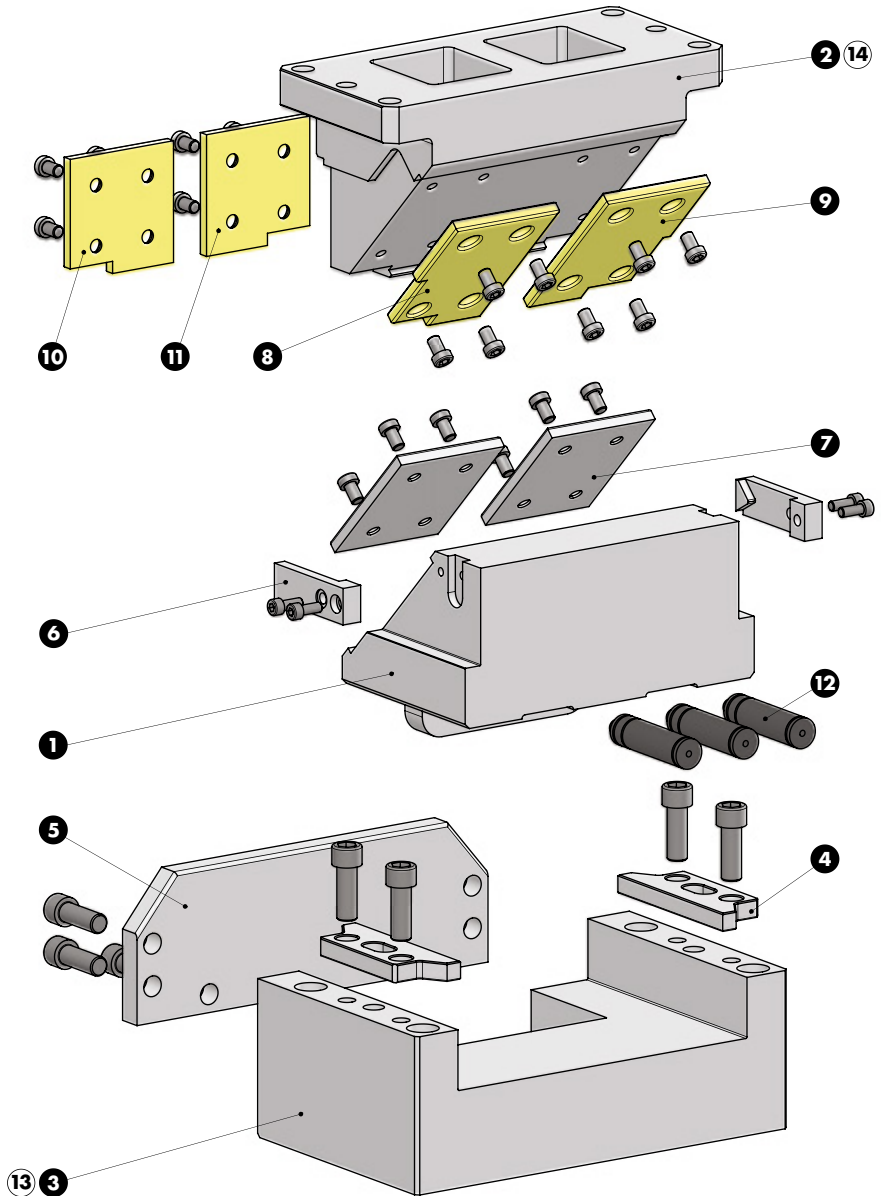



DIE MOUNTED CAM UNIT - HORIZONTALSCHIEBER - UNITÀ A CAMME A BASE STAMPO

SLIDER STRUCTURE, POSITIVE RETURN STRUCTURE AND CLEARANCES

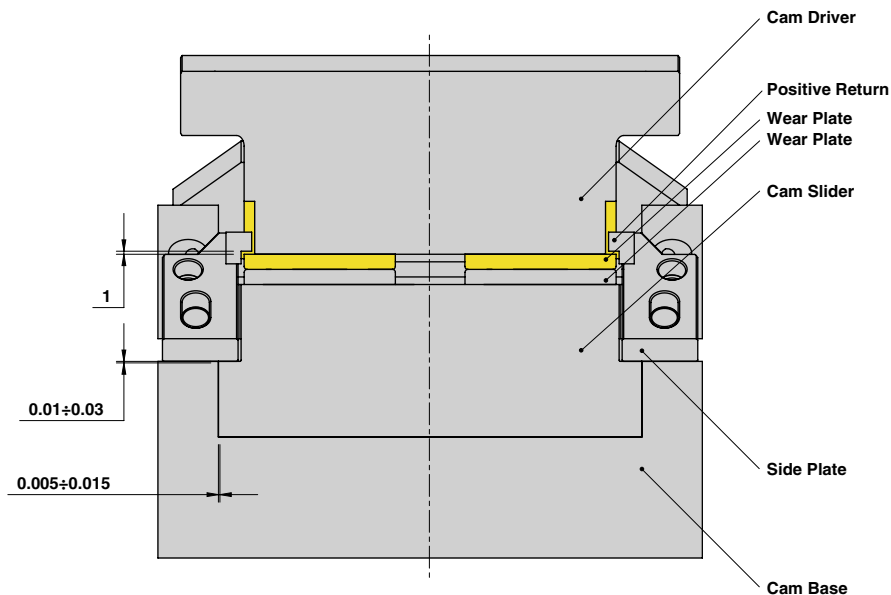

PART LIST

Particular number	Description	Material	Quantity
1	Cam Slider	GGG-50 + Graphite	1
2	Cam Driver	GG-25	1
3	Cam Base	GG-25	1
4	Side Plate	CK45	2
5	Stopper Plate	CK45	1
6	Positive Return	CK45	2
7	Wear Plate	CK45	2
8	Wear Plate	CuZn25Al5 + Graphite - HB > 190	1
9	Wear Plate	CuZn25Al5 + Graphite - HB > 190	1
10	Wear Plate	CuZn25Al5 + Graphite - HB > 190	1
11	Wear Plate	CuZn25Al5 + Graphite - HB > 190	1
12	Gas Spring	-	3
13	Cam Base Fixing Screws M16x90 DIN 912	-	4
14	Cam Driver Fixing Screws M16x60 DIN 912	-	4



DIE MOUNTED CAM UNIT - HORIZONTALSCHIEBER - UNITÀ A CAMME A BASE STAMPO

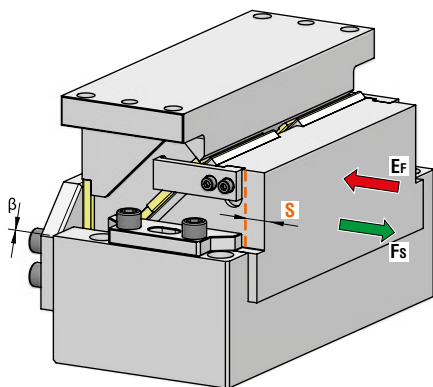

OMCR CODE	Work Angle	Stroke (mm)	Max Work Force with shoulder (kN)	Extraction Force (kN)
	β	S	F _s	E _f Gas Spring
DHC300.00.40	0°	40	272	8,6
DHC300.00.60	0°	60	272	9,4



P.605

STOCK	ORDER EXAMPLE	Art.	Work Angle = 0°	Stroke = 60
		DHC300	00	60

OMCR CODE	Work Angle	Stroke	Overall Dimensions (mm)						
	β	S	A	B	C	D	E	F	G
DHC300.00.40	0°	40	210	200	135	105	100	70	140
DHC300.00.60	0°	60	230	220	155	125	120	80	160



DIE MOUNTED CAM UNIT - HORIZONTALSCHIEBER - UNITÀ A CAMME A BASE STAMPO

X VIEW

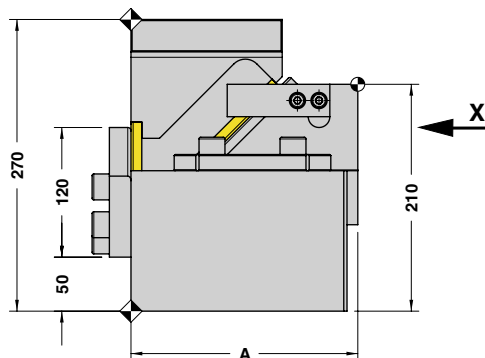
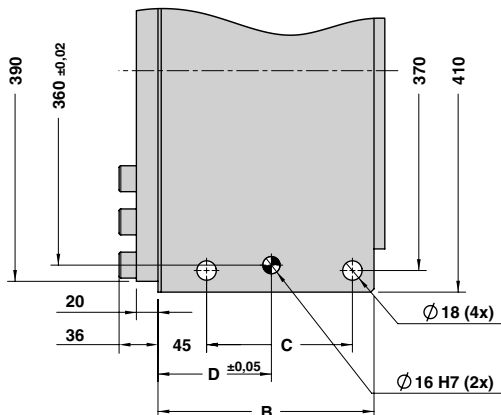
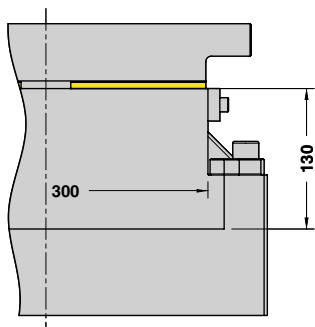

CAM DIAGRAM

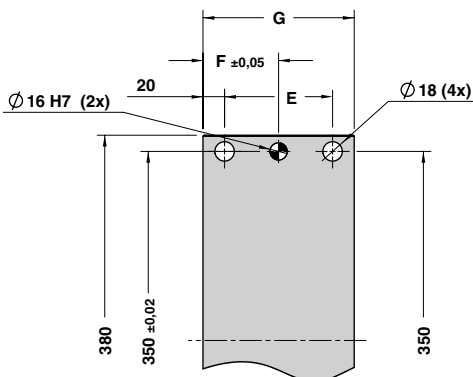
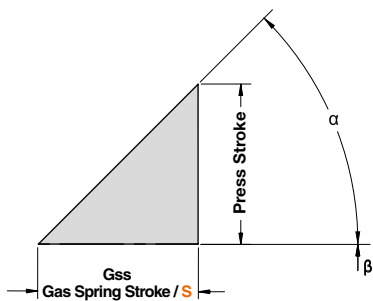

Work Angle	Inner Angle	Slider Work Stroke (mm)	Press Stroke (mm)	Gas Spring Stroke (mm)
β	α	S	Ps	Gss
0°	45°	40	40	40
0°	45°	60	60	60

Cam Units DHC



DIE MOUNTED CAM UNIT - HORIZONTALSCHIEBER - UNITÀ A CAMME A BASE STAMPO

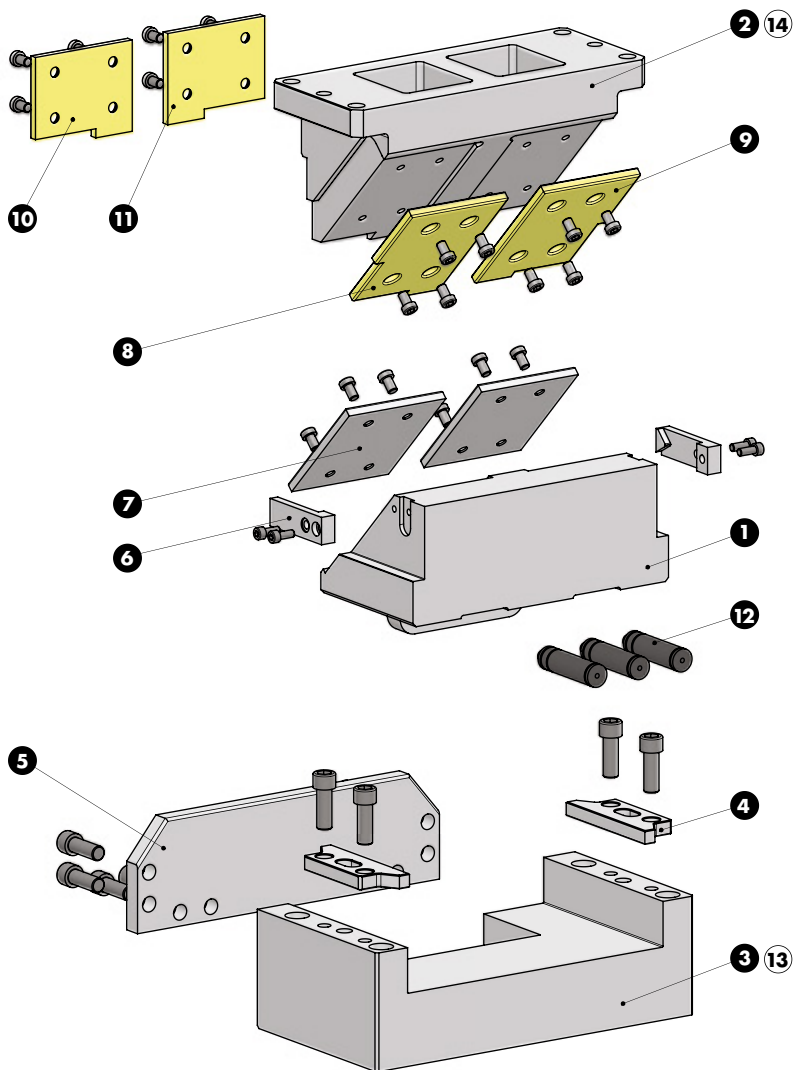



DIE MOUNTED CAM UNIT - HORIZONTALSCHIEBER - UNITÀ A CAMME A BASE STAMPO

SLIDER STRUCTURE, POSITIVE RETURN STRUCTURE AND CLEARANCES

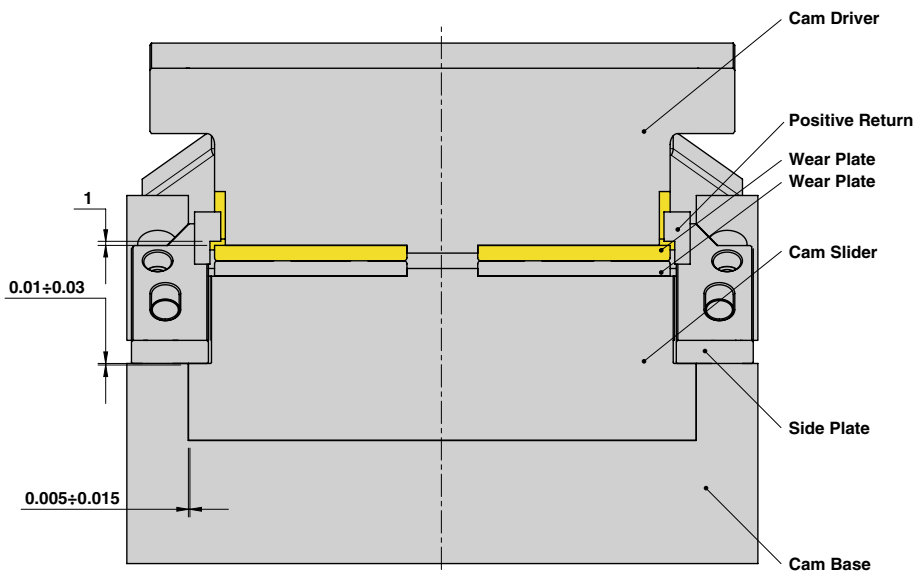

PART LIST

Particular number	Description	Material	Quantity
1	Cam Slider	GGG-50 + Graphite	1
2	Cam Driver	GG-25	1
3	Cam Base	GG-25	1
4	Side Plate	CK45	2
5	Stopper Plate	CK45	1
6	Positive Return	CK45	2
7	Wear Plate	CK45	2
8	Wear Plate	CuZn25Al5 + Graphite - HB > 190	1
9	Wear Plate	CuZn25Al5 + Graphite - HB > 190	1
10	Wear Plate	CuZn25Al5 + Graphite - HB > 190	1
11	Wear Plate	CuZn25Al5 + Graphite - HB > 190	1
12	Gas Spring	-	3
13	Cam Base Fixing Screws M16x90 DIN 912	-	4
14	Cam Driver Fixing Screws M16x60 DIN 912	-	4



DIE MOUNTED CAM UNIT - HORIZONTALSCHIEBER - UNITÀ A CAMME A BASE STAMPO

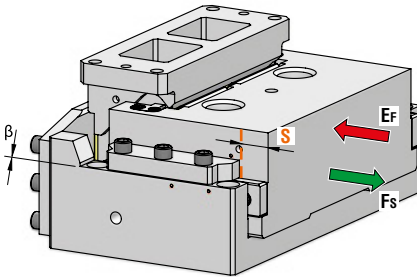

OMCR CODE	Work Angle	Stroke (mm)	Max Work Force with shoulder (kN)	Extraction Force (kN)
	β	S	Fs	Ef Gas Spring
DHC400.00.60	0°	60	480	25,2



P.605

STOCK	ORDER EXAMPLE	Art.	Work Angle = 0°	Stroke = 60
		DHC400	00	60



DIE MOUNTED CAM UNIT - HORIZONTALSCHIEBER - UNITÀ A CAMME A BASE STAMPO

X VIEW

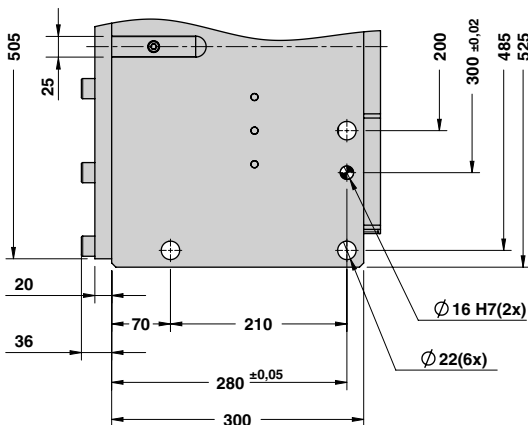
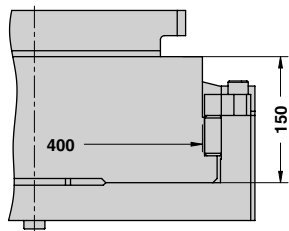

CAM DIAGRAM

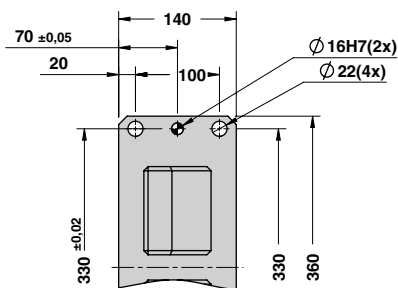
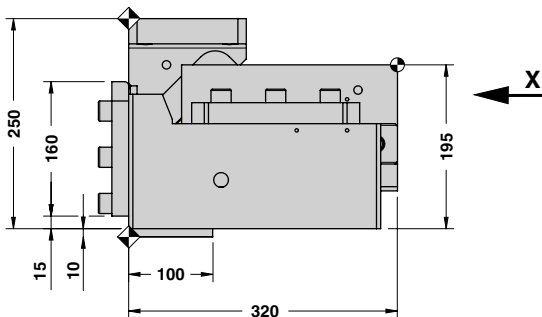
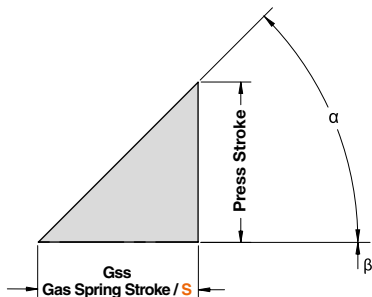

Work Angle	Inner Angle	Slider Work Stroke (mm)	Press Stroke (mm)	Gas Spring Stroke (mm)
β	α	S	Ps	Gss
0°	45°	60	60	60

Cam Units DHC



DIE MOUNTED CAM UNIT - HORIZONTALSCHIEBER - UNITÀ A CAMME A BASE STAMPO

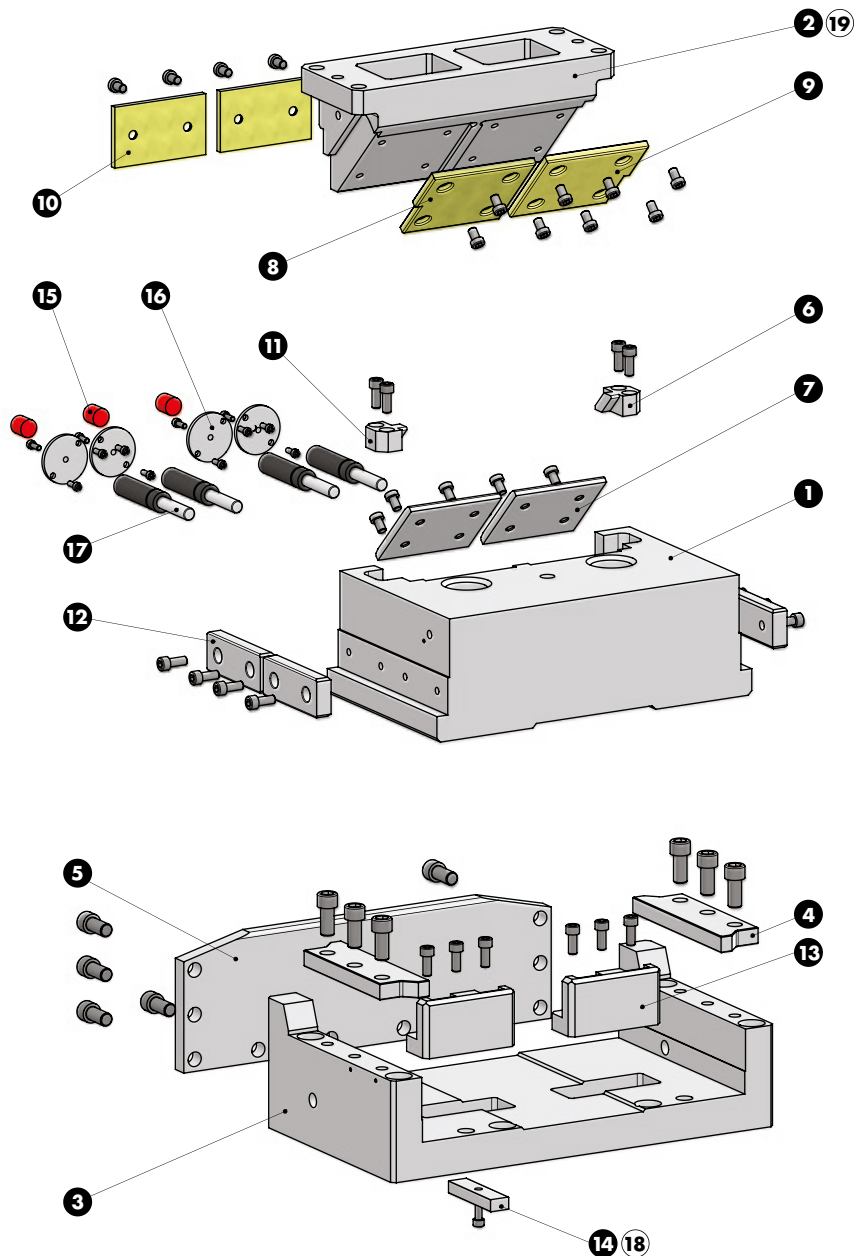



DIE MOUNTED CAM UNIT - HORIZONTALSCHIEBER - UNITÀ A CAMME A BASE STAMPO

SLIDER STRUCTURE, POSITIVE RETURN STRUCTURE AND CLEARANCES

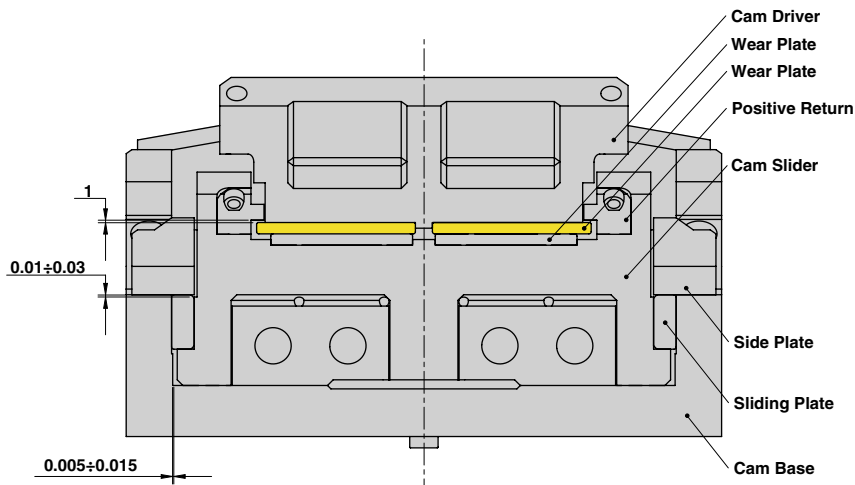

PART LIST

Particular number	Description	Material	Quantity
1	Cam Slider	GGG-50 + Graphite	1
2	Cam Driver	GG-25	1
3	Cam Base	GG-25	1
4	Side Plate	GG-25 + Graphite	2
5	Stopper Plate	CK45	1
6	Positive Return R	CK45	1
7	Wear Plate	CK45	2
8	Wear Plate	CuZn25Al5 + Graphite - HB > 190	1
9	Wear Plate	CuZn25Al5 + Graphite - HB > 190	1
10	Wear Plate	CuZn25Al5 + Graphite - HB > 190	2
11	Positive Return L	CK45	1
12	Slide Plate	GG-25 + Graphite	4
13	Spring Stopper	CK45	2
14	Key	CK45	1
15	Elastomer Cap	Elastomer 92SH	3
16	Gas Spring Stopper Plate	CK45	4
17	Gas Spring	-	4
18	Cam Base Fixing Screws M20x90 DIN 912	-	4
19	Cam Driver Fixing Screws M16x55 DIN 912	-	4