

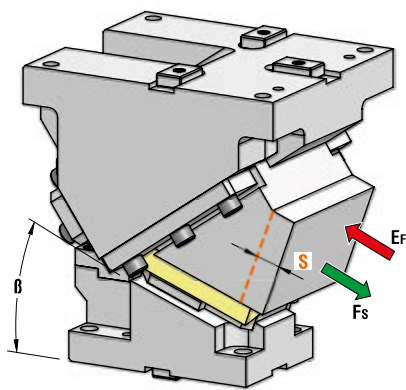

AERIAL CAM UNIT - OBEN HÄNGENDER SCHIEBER - UNITÀ A CAMME SOSPESA



P.605

OMCR CODE	Work Angle	Stroke (mm)	Max Work Force with shoulder (kN)	Extraction Force (kN)	
				Spring	Gas Spring
CHD180.00	0°	28,68	396	2,29	7,15
CHD180.05	5°	32,26	396	2,29	7,15
CHD180.10	10°	35,90	396	2,29	7,15
CHD180.15	15°	39,65	396	2,29	7,15
CHD180.20	20°	43,59	396	2,29	7,15
CHD180.25	25°	47,78	396	2,29	7,15
CHD180.30	30°	52,33	396	2,29	7,15
CHD180.35	35°	57,36	396	2,29	7,15
CHD180.40	40°	63,05	396	2,29	7,15
CHD180.45	45°	69,64	396	2,29	7,15
CHD180.50	50°	77,49	396	2,29	7,15
CHD180.55	55°	87,17	396	2,29	7,15
CHD180.60	60°	99,62	396	2,29	7,15
CHD180.65	65°	116,51	396	2,29	7,15

*Return Type: G = Gas Spring / S = Spring

15	ORDER EXAMPLE	Art.	Work Angle = 5°	Return Type*
		CHD180	05	G

OMCR CODE	Work Angle	Overall Dimensions (mm)				
		β	A	B	C	D
CHD180.00	0°	325	130	80	310	25
CHD180.05	5°	319,70	133,26	60	290	25
CHD180.10	10°	319,06	137,79	45	275	25
CHD180.15	15°	322,98	143,56	35	265	20
CHD180.20	20°	326,33	150,51	25	255	15
CHD180.25	25°	329,03	158,61	15	245	10
CHD180.30	30°	325,98	167,78	0	230	0
CHD180.35	35°	322,08	192,95	-15	215	0
CHD180.40	40°	312,26	204,06	-35	195	0
CHD180.45	45°	306,42	216,01	-50	180	0
CHD180.50	50°	294,51	228,71	-70	160	0
CHD180.55	55°	281,46	242,07	-90	140	0
CHD180.60	60°	272,22	255,98	-105	125	0
CHD180.65	65°	261,75	270,34	-120	110	0



AERIAL CAM UNIT - OBEN HÄNGENDER SCHIEBER - UNITÀ A CAMME SOSPESA

X VIEW

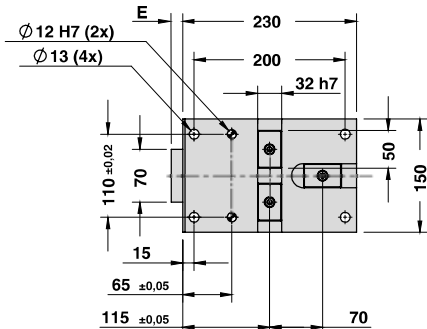
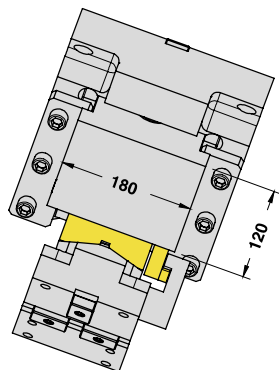

CAM DIAGRAM

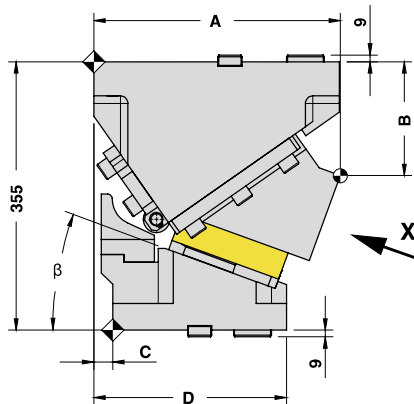
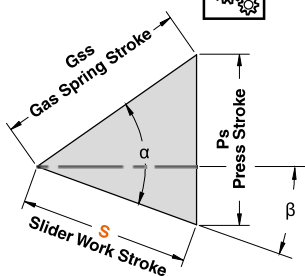

Cam Units CHD

Work Angle	Inner Angle	Slider Work Stroke (mm)	Press Stroke (mm)	Gas Spring Stroke (mm)
β	α	S	Ps	Gss
0°	55°	28,68	40,96	50
5°	55°	32,26	41,11	50
10°	55°	35,90	41,59	50
15°	55°	39,65	42,40	50
20°	55°	43,59	43,59	50
25°	55°	47,78	45,19	50
30°	55°	52,33	47,29	50
35°	55°	57,36	50,00	50
40°	55°	63,05	53,47	50
45°	55°	69,64	57,92	50
50°	55°	77,49	63,72	50
55°	55°	87,17	71,41	50
60°	55°	99,62	81,92	50
65°	55°	116,51	96,91	50

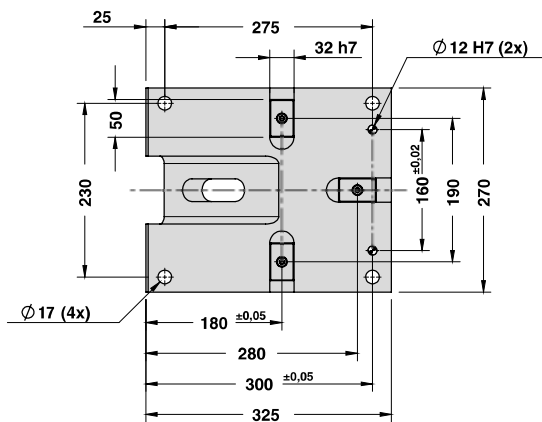



AERIAL CAM UNIT - OBEN HÄNGENDER SCHIEBER - UNITÀ A CAMME SOSPESA

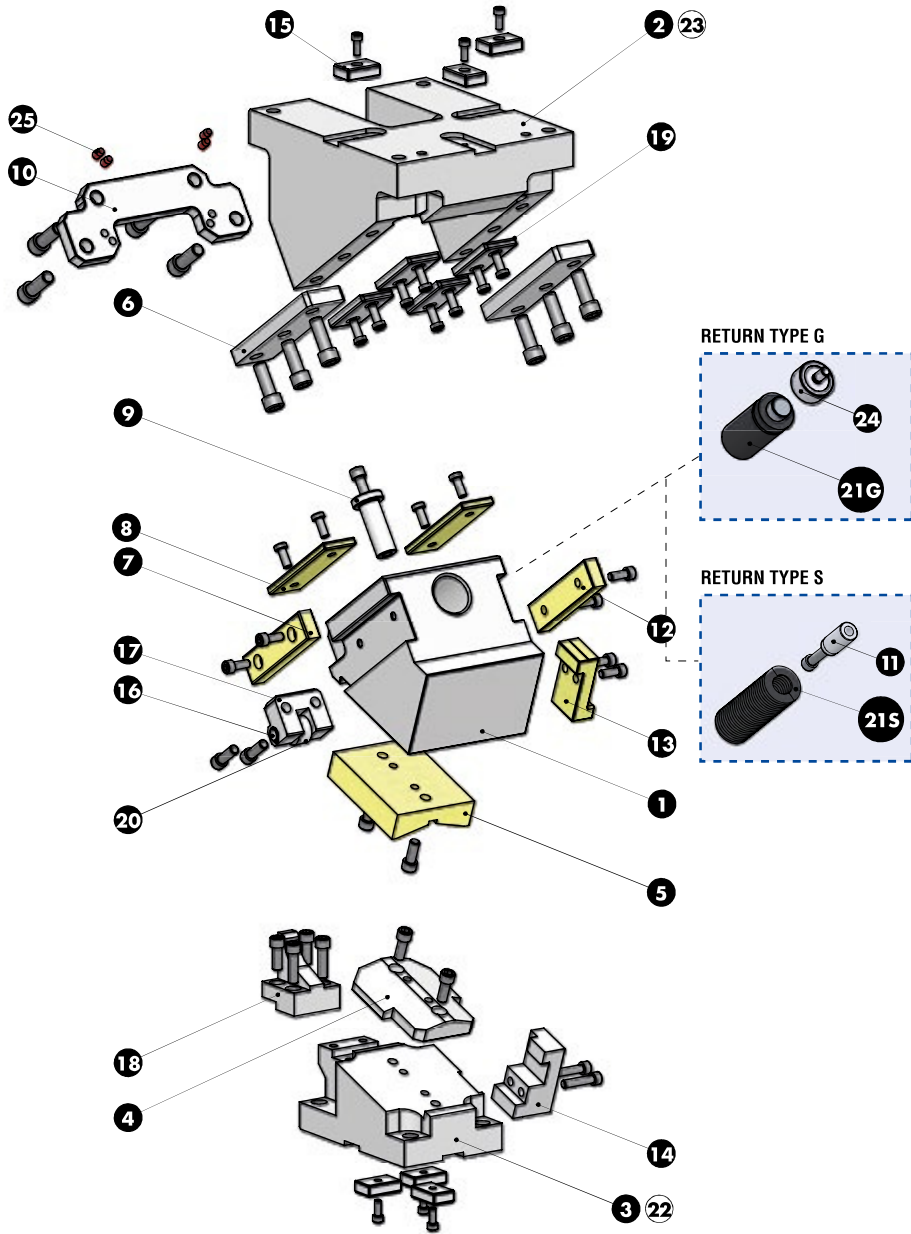



AERIAL CAM UNIT - OBEN HÄNGENDER SCHIEBER - UNITÀ A CAMME SOSPESA

SLIDER STRUCTURE, POSITIVE RETURN STRUCTURE AND CLEARANCES

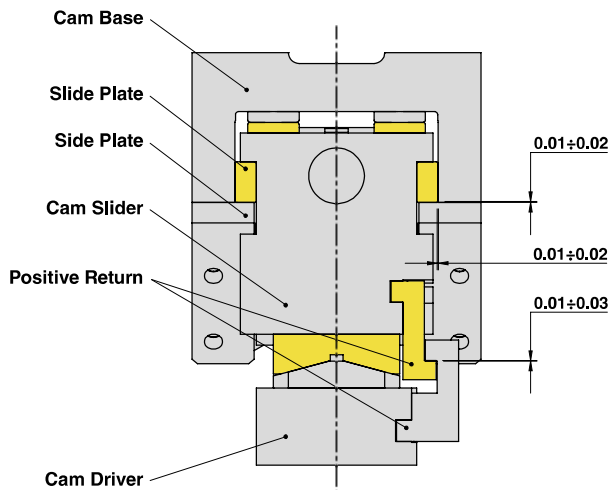

PART LIST

Particular number	Description	Material	Quantity
1	Cam Slider	GG-30	1
2	Cam Base	GG-30	1
3	Cam Driver	GG-30	1
4	Male "V" Driver	CK45	1
5	Female "V" Driver	CuZn25Al5 + Graphite - HB > 190	1
6	Side Plate	CK45	2
7	Slide Plate L	CuZn25Al5 + Graphite - HB > 190	1
8	Wear Plate	CuZn25Al5 + Graphite - HB > 190	2
9	Safety Pin	CK45	1
10	Stopper Plate	St 52	1
11	Spring Guide Pin	CK45	1
12	Slide Plate R	CuZn25Al5 + Graphite - HB > 190	1
13	Positive Return	CuZn25Al5 - HB > 190	1
14	Positive Return	42CrMo4 Nitrided	1
15	Key	CK45	6
16	Shaft	CK45	1
17	Roller Bracket	CK45	1
18	Accelerator	CK45	1
19	Wear Plate	CK45	4
20	Roller	NATR15PP	1
21G	Gas Spring - Return Type G	-	1
21S	Spring - Return Type S	-	1
22	Cam Driver Fixing Screws M12x50 DIN 912	-	4
23	Cam Base Fixing Screws M16x70 DIN 912	-	4
24	Gas Spring Spacer	CK45	1
25	Elastomer Cap	Elastomer 92SH	4

Cam Units CHD