

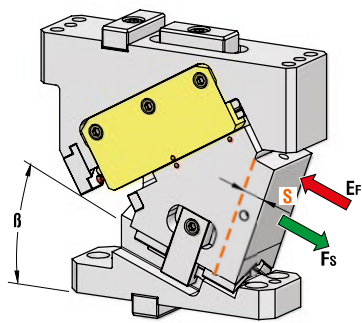

**AERIAL CAM UNIT - OBEN HÄNGENDER SCHIEBER - UNITÀ A CAMME SOSPESA**



P.605

OMCR CODE	Work Angle	Stroke (mm)	Max Work Force with shoulder (kN)	Extraction Force (kN)
	$\beta$	S	F <sub>s</sub>	E <sub>f</sub>
				Gas Spring
CHV050.00	0°	28,93	92	4,5
CHV050.05	5°	31,94	92	4,8
CHV050.10	10°	35,00	92	4,8
CHV050.15	15°	38,16	92	4,8
CHV050.20	20°	41,47	92	4,8
CHV050.25	25°	45,00	92	4,8
CHV050.30	30°	48,83	92	4,8
CHV050.35	35°	53,06	92	4,8
CHV050.40	40°	57,85	92	4,8
CHV050.45	45°	63,40	92	4,8
CHV050.50	50°	62,23	92	4,6
CHV050.55	55°	59,28	98	4,7
CHV050.60	60°	60,00	104	5,1
CHV050.65	65°	59,16	110	5,3
CHV050.70	70°	58,48	110	5,7
CHV050.75	75°	57,96	110	6,1

STOCK	ORDER EXAMPLE	Art.	Work Angle = 5°
		CHV050	05

OMCR CODE	Work Angle	Overall Dimensions (mm)													
		$\beta$	A	B	C	D	E	F	G	H	I	J	K	L	M
CHV050.00	0°	170	57	38	193	155	129	120	50	162	160	180	175	68,5	20
CHV050.05	5°	173,89	60,44	35	190	155	129	120	50	167	165	185	175	68,5	20
CHV050.10	10°	177,66	64,77	32	187	155	129	120	50	172	170	190	175	68,5	20
CHV050.15	15°	180,31	67,99	28	183	155	129	120	50	177	175	195	175	68,5	20
CHV050.20	20°	180,87	71,09	22	177	155	129	120	50	177	175	195	175	68,5	20
CHV050.25	25°	180,34	74,06	16	171	155	129	120	50	177	175	195	175	68,5	20
CHV050.30	30°	180,72	76,89	10	165	155	129	120	50	179	177	197	175	68,5	20
CHV050.35	35°	179,04	79,58	3	158	155	129	120	50	179	177	197	175	68,5	20
CHV050.40	40°	176,31	83,12	-9	146	155	129	120	50	179	177	197	175	68,5	20
CHV050.45	45°	172,54	85,51	-18	137	155	129	120	50	177	175	195	175	68,5	20
CHV050.50	50°	161,73	93,74	-33	122	155	129	120	50	172	170	190	180	68,5	20
CHV050.55	55°	168,28	97,72	-39	116	155	129	120	35	172	170	190	185	75	80
CHV050.60	60°	173,67	104,06	-49	106	155	129	120	35	172	170	190	190	85	80
CHV050.65	65°	169,28	113,98	-53	92	145	119	110	35	172	170	190	195	90	80
CHV050.70	70°	166,95	124,76	-63	72	135	109	100	35	172	170	190	195	100	90
CHV050.75	75°	165,42	134,11	-68	67	135	109	100	35	172	170	190	195	100	90



AERIAL CAM UNIT - OBEN HÄNGENDER SCHIEBER - UNITÀ A CAMME SOSPESA

X VIEW

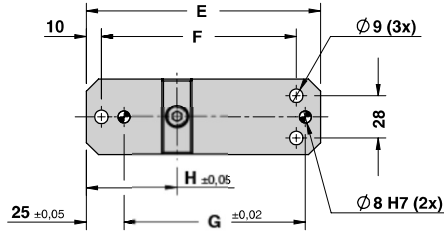
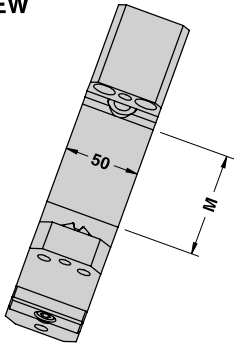

CAM DIAGRAM

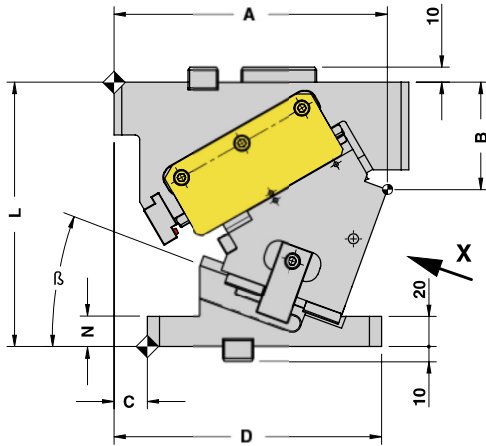
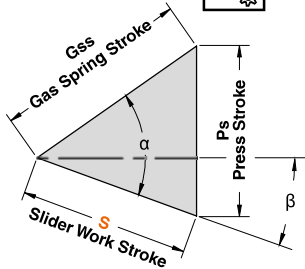

Cam Units CHV

Work Angle	Inner Angle	Slider Work Stroke (mm)	Press Stroke (mm)	Gas Spring Stroke (mm)
$\beta$	$\alpha$	S	Ps	Gss
0°	50°	28,93	34,47	45
5°	50°	31,94	34,60	45
10°	50°	35,00	35,00	45
15°	50°	38,16	35,69	45
20°	50°	41,47	36,68	45
25°	50°	45,00	38,04	45
30°	50°	48,83	39,80	45
35°	50°	53,06	42,08	45
40°	50°	57,85	45,00	45
45°	50°	63,40	48,75	45
50°	50°	62,23	47,67	40
55°	55°	59,28	48,56	34
60°	60°	60,00	51,96	30
65°	65°	59,16	53,61	25
70°	70°	58,48	54,95	20
75°	75°	57,96	55,98	15

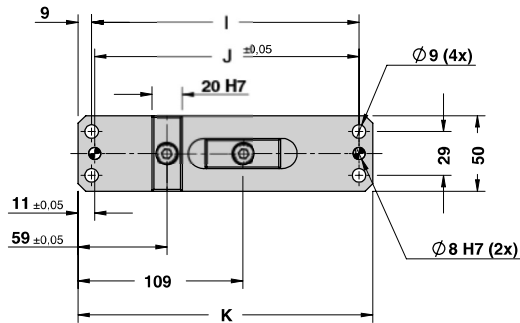



AERIAL CAM UNIT - OBEN HÄNGENDER SCHIEBER - UNITÀ A CAMME SOSPESA

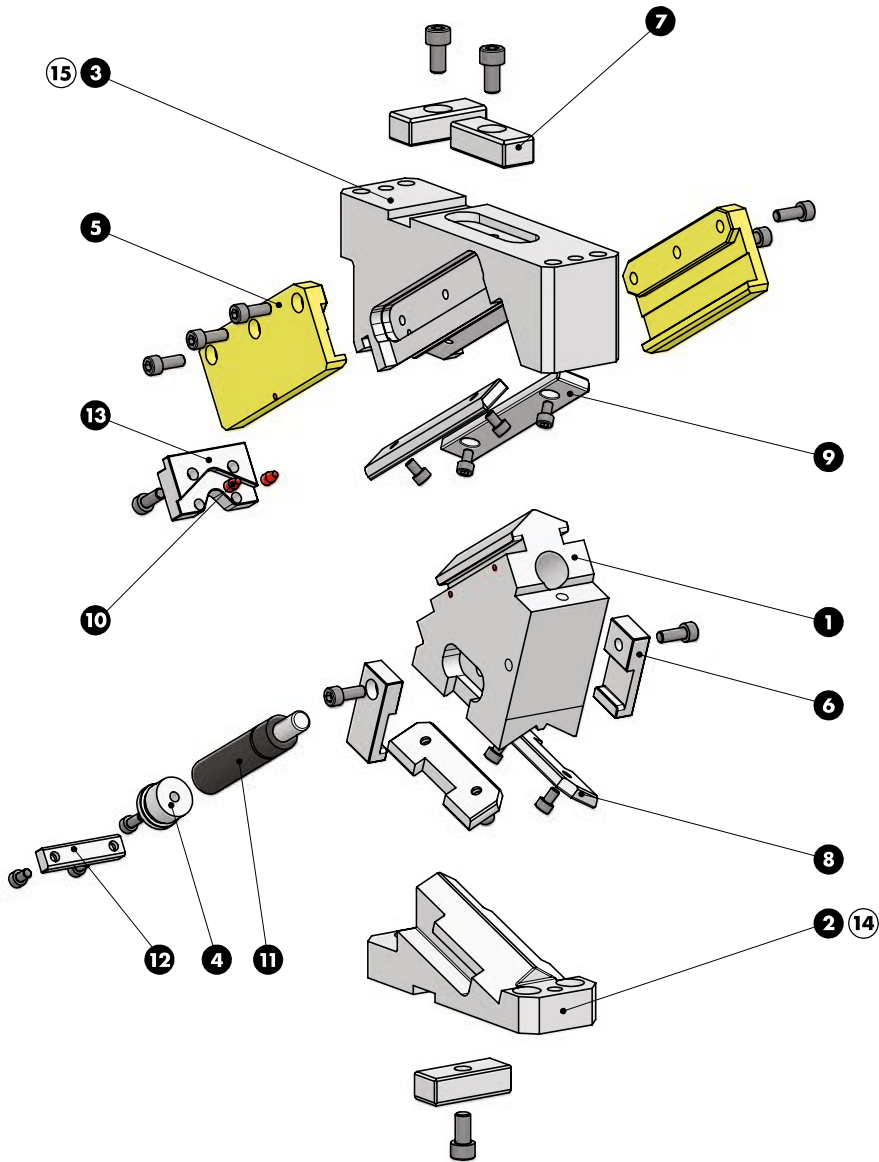



**AERIAL CAM UNIT - OBEN HÄNGENDER SCHIEBER - UNITÀ A CAMME SOSPESA**

**SLIDER STRUCTURE, POSITIVE RETURN STRUCTURE AND CLEARANCES**

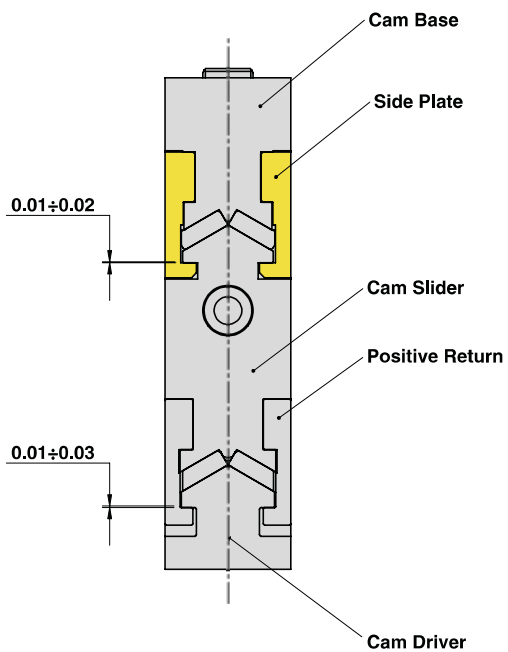

Cam Units CHV

**PART LIST**

Particular number	Description	Material	Quantity
1	Cam Slider	42CrMo4	1
2	Cam Driver	42CrMo4	1
3	Cam Base	42CrMo4	1
4	Spring spacer	CK45	1
5	Side Plate	CuZn25Al5 + Graphite - HB > 190	2
6	Positive Return	42CrMo4 Nitrided	2
7	Key	CK45	1
8	Wear Plate	St42 + Syntered layer	2
9	Wear Plate	St42 + Syntered layer	2
10	Elastomer Cap	Elastomer 92SH	2
11	Gas Spring	-	1
12	Safety plate	CK45	1
13	Stopper plate	CK45	1
14	Cam Driver Fixing Screws M8x25 DIN 912 Cl. 12.9	-	3
15	Cam Base Fixing Screws M8x30 DIN 912 Cl. 12.9	-	4
-	Lockout System	(more info on OMCR website)	1

