

AERIAL CAM UNIT - OBEN HÄNGENDER SCHIEBER - UNITÀ A CAMME SOSPESA

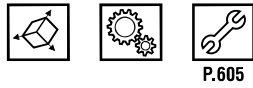
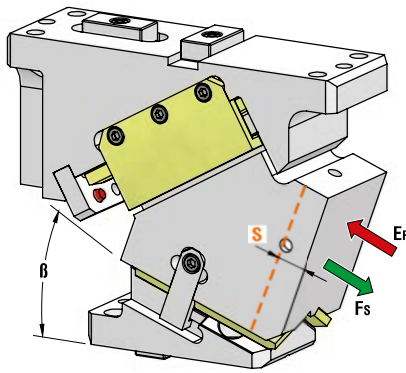

OMCR CODE	Work Angle β	Max Stroke (mm) S	Max Work Force with shoulder (kN) Fs	Extraction Force (kN)
				Ef Gas Spring
CHY085.00	0°	19,28	106	3,47
CHY085.05	5°	21,29	106	3,47
CHY085.10	10°	23,34	106	3,47
CHY085.15	15°	25,44	106	3,47
CHY085.20	20°	27,65	106	3,47
CHY085.25	25°	30	106	3,47
CHY085.30	30°	32,55	106	3,47
CHY085.35	35°	35,38	106	3,47
CHY085.40	40°	38,57	106	3,47
CHY085.45	45°	42,26	106	3,47
CHY085.50	50°	46,67	106	3,47
CHY085.55	55°	52,30	106	3,10
CHY085.60	60°	60	106	2,70
CHY085.65	65°	70,99	106	2,28
CHY085.70	70°	58,48	106	1,83
CHY085.75	75°	77,27	106	1,38

		Art.	Work Angle = 5°
		CHY085	05

OMCR CODE	Work Angle β	Overall Dimensions (mm)							
		A	B	C	D	E	F	G	H
CHY085.00	0°	267	63	115	265	150	97	49,5	130
CHY085.05	5°	272,39	67,16	110	260	150	97	49,5	130
CHY085.10	10°	275,07	71,77	101	251	150	97	49,5	130
CHY085.15	15°	277,99	79,72	92	242	150	97	49,5	130
CHY085.20	20°	273,08	88,43	69	219	150	97	49,5	130
CHY085.25	25°	271,30	94,15	60	210	150	97	49,5	130
CHY085.30	30°	269,61	100,26	52	202	150	97	49,5	130
CHY085.35	35°	265,99	103,46	47	197	150	97	49,5	130
CHY085.40	40°	262,39	110,53	37	177	140	87	42,5	120
CHY085.45	45°	256,82	117,97	23	163	140	87	42,5	120
CHY085.50	50°	249,24	133,48	20	150	130	77	32,5	110
CHY085.55	55°	250,67	140,79	19	149	130	77	32,5	110
CHY085.60	60°	240,10	149,35	4	134	130	77	32,5	110
CHY085.65	65°	235	159,05	-5	125	130	77	32,5	110
CHY085.70	70°	230	168,88	-15	115	130	80	32,5	110
CHY085.75	75°	228	186,99	-25	105	130	90	32,5	110

AERIAL CAM UNIT - OBEN HÄNGENDER SCHIEBER - UNITÀ A CAMME SOSPESA

X VIEW

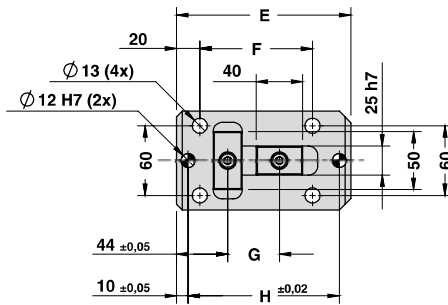
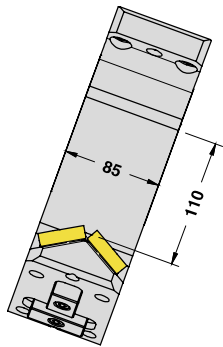

CAM DIAGRAM

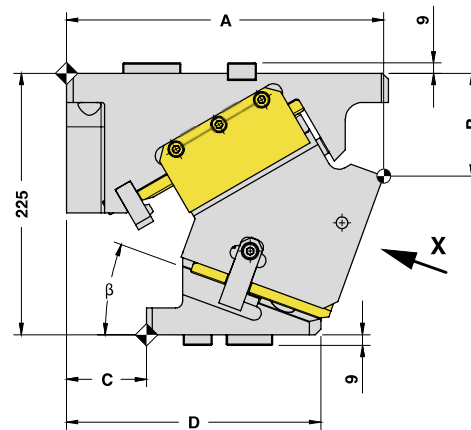
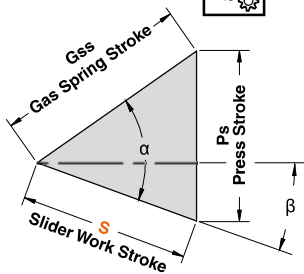

Cam Units CHY

Work Angle	Inner Angle	Slider Work Stroke (mm)	Press Stroke (mm)	Gas Spring Stroke (mm)
β	α	S	Ps	Gss
0°	50°	19,28	22,98	30
5°	50°	21,29	23,07	30
10°	50°	23,34	23,34	30
15°	50°	25,44	23,79	30
20°	50°	27,65	24,46	30
25°	50°	30,00	25,36	30
30°	50°	32,55	26,54	30
35°	50°	35,38	28,06	30
40°	50°	38,57	30,00	30
45°	50°	42,26	32,50	30
50°	50°	46,67	35,75	30
55°	55°	52,30	42,84	30
60°	60°	60,00	51,96	30
65°	65°	70,99	64,34	30
70°	70°	84,48	80,95	20
75°	75°	100,27	100,64	20

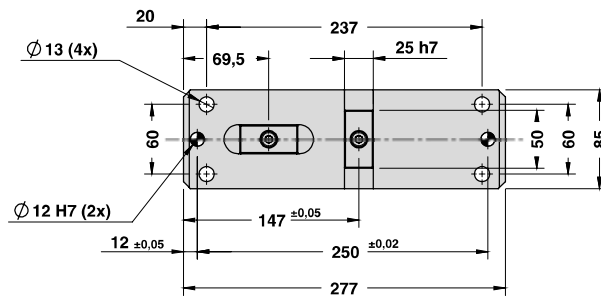

AERIAL CAM UNIT - OBEN HÄNGENDER SCHIEBER - UNITÀ A CAMME SOSPESA

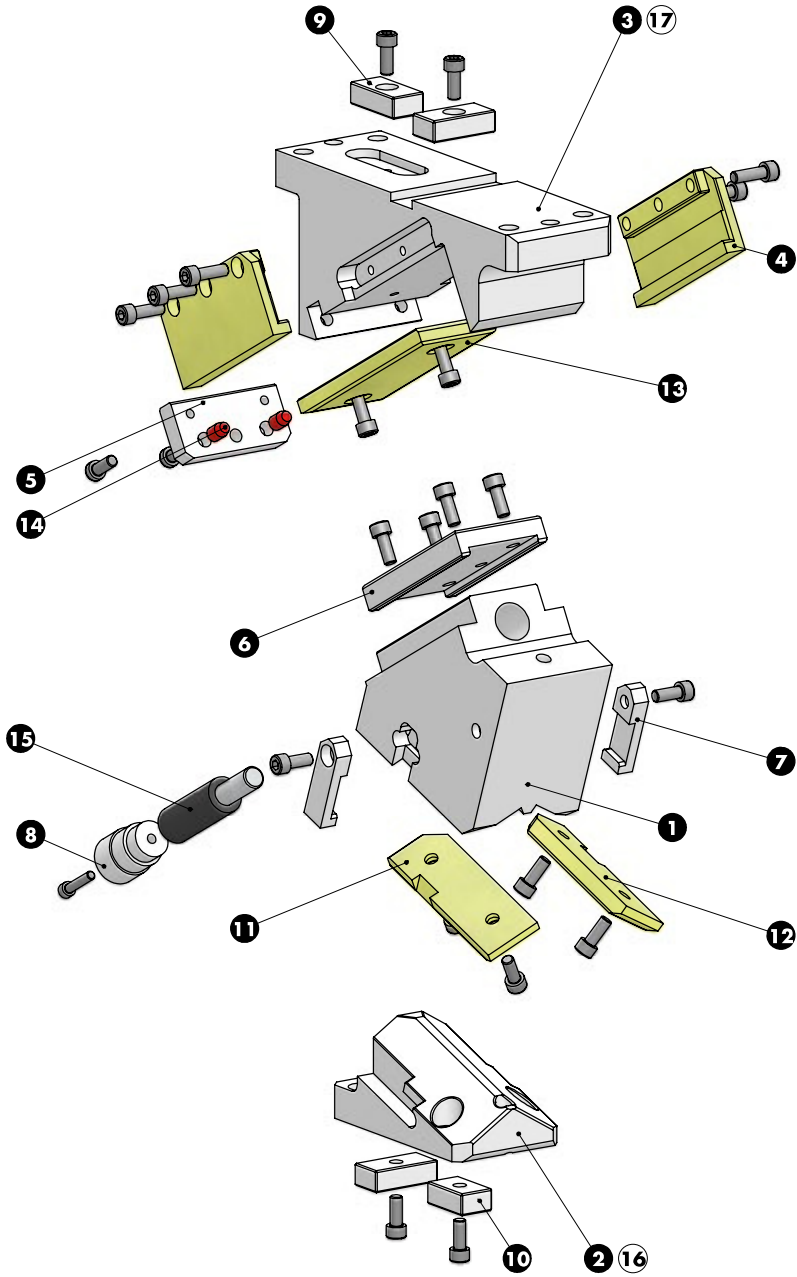

AERIAL CAM UNIT - OBEN HÄNGENDER SCHIEBER - UNITÀ A CAMME SOSPESA

SLIDER STRUCTURE, POSITIVE RETURN STRUCTURE AND CLEARANCES

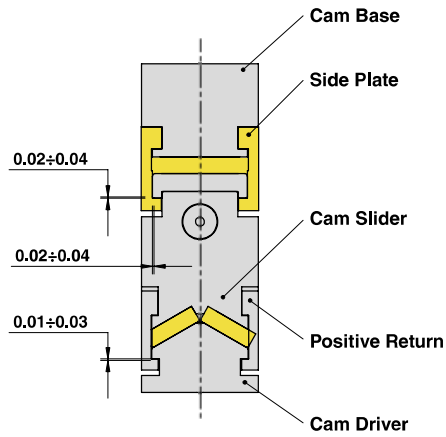

Cam Units CHY

PART LIST

Particular number	Description	Material	Quantity
1	Cam Slider	GGG-60	1
2	Cam Driver	GGG-60	1
3	Cam Base	GGG-60	1
4	Side Plate	CuZn25Al5 + Graphite - HB > 190	2
5	Stopper Plate	St44	1
6	Wear Plate	CK45	1
7	Positive Return	CK45	2
8	Spring Spacer	CK45	1
9	Key	CK45	3
10	Key	CK45	1
11	Wear Plate L	CuZn25Al5 + Graphite - HB > 190	1
12	Wear Plate R	CuZn25Al5 + Graphite - HB > 190	1
13	Wear Plate VDI 3357	CuZn25Al5 + Graphite - HB > 190	1
14	Elastomer Cap	Elastomer 92SH	2
15	Gas Spring	-	1
16	Cam Driver Fixing Screws M12x40 DIN 912	-	4
17	Cam Base Fixing Screws M12x45 DIN 912	-	4