

Cam Units CLB
Schieber CLB
Unità a Camme CLB



OMCR[®]
STANDARD DIE COMPONENTS

2018.01



OMCR CODE	Work Angle	Slider Width (mm)	Closed Cam Height (mm)	Work Area W x H (mm)	Max Work Force with shoulder 10 ⁶ cycles (kN)	Extraction Force (kN)		Page number
						E _F		
	β				F _s	Spring	Gas Spring	
CLB200	0°÷60° (5° steps)	200	350	200x180	302	2,12÷2,73	8,88÷11,42	780
CLB300	0°÷60° (5° steps)	300	350	300x180	411	4,25÷5,46	17,76÷22,83	784
CLB400	0°÷60° (5° steps)	400	350	400x180	526	4,25÷5,46	17,76÷22,83	788
CLB500	0°÷60° (5° steps)	500	350	500x180	743	6,37÷8,19	26,64÷34,25	792
CLB600	0°÷60° (5° steps)	600	350	600x180	865	8,50÷10,92	35,52÷45,67	796

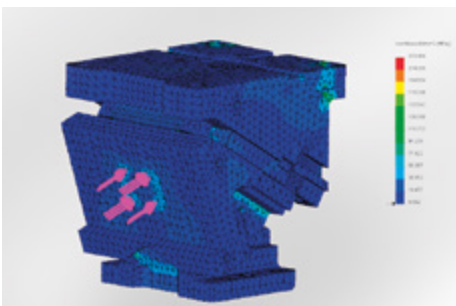
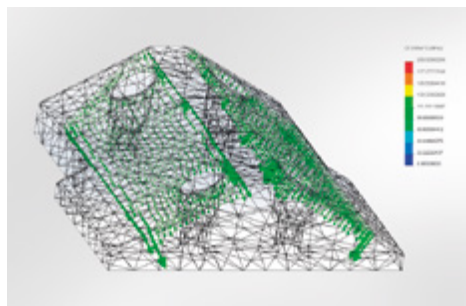

Research and product development



AERIAL CAM UNIT - OBEN HÄNGENDER SCHIEBER - UNITÀ A CAMME SOSPESA

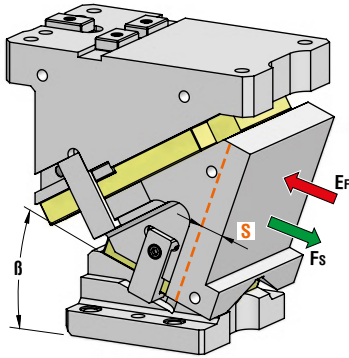

P.605

OMCR CODE	Work Angle β	Stroke (mm) S	Max Work Force with shoulder (kN) F_s	Extraction Force (kN) E_f	
				Spring	Gas Spring
CLB200.00	0°	38,57	302	2,73	11,42
CLB200.05	5°	42,59	302	2,73	11,42
CLB200.10	10°	46,67	302	2,73	11,42
CLB200.15	15°	50,88	302	2,73	11,42
CLB200.20	20°	55,30	302	2,73	11,42
CLB200.25	25°	60	302	2,73	11,42
CLB200.30	30°	65,10	302	2,73	11,42
CLB200.35	35°	70,75	302	2,73	11,42
CLB200.40	40°	77,13	302	2,73	11,42
CLB200.45	45°	84,53	302	2,73	11,42
CLB200.50	50°	93,34	302	2,73	11,42
CLB200.55	55°	104,61	302	2,12	8,88
CLB200.60	60°	120	302	2,12	8,88

Return Type: **G** = Gas Spring / **S** = Spring



Art.	Work Angle = 5°	Return type
CLB200	05	G

OMCR CODE	Work Angle β	Overall Dimensions (mm)			
		A	B	C	D
CLB200.00	0°	313	58	138	328
CLB200.05	5°	320,64	64,34	125	315
CLB200.10	10°	331,08	72,47	115	305
CLB200.15	15°	336,17	82,37	100	290
CLB200.20	20°	340,76	94	85	275
CLB200.25	25°	344,69	102,32	70	260
CLB200.30	30°	347,83	112,25	55	245
CLB200.35	35°	355,03	123,73	45	235
CLB200.40	40°	351,17	136,66	25	215
CLB200.45	45°	356,12	150,95	15	205
CLB200.50	50°	348,77	161,49	-6	184
CLB200.55	55°	352,01	178,16	-15	175
CLB200.60	60°	332,75	195,83	-45	145



AERIAL CAM UNIT - OBEN HÄNGENDER SCHIEBER - UNITÀ A CAMME SOSPESA

X VIEW

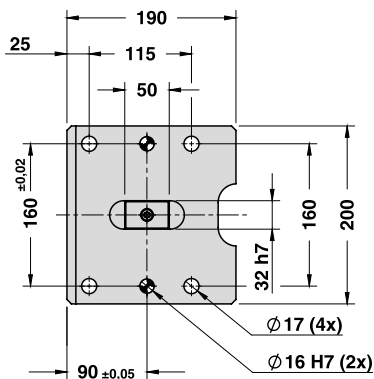
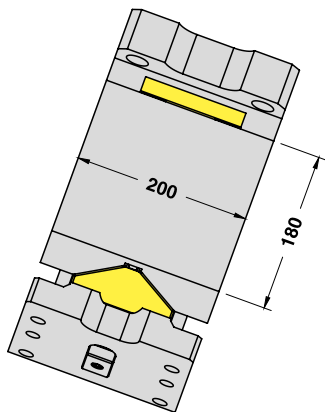

CAM DIAGRAM

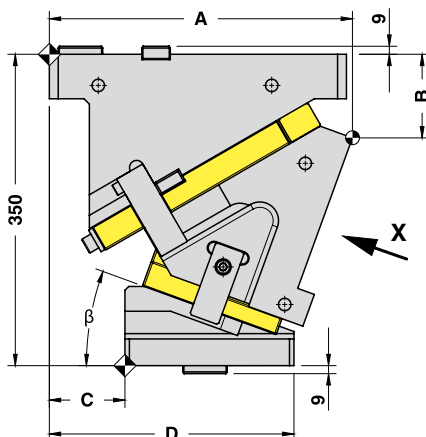
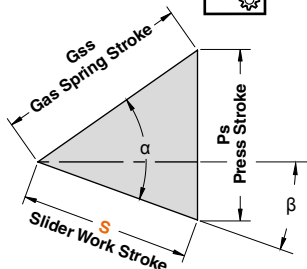

Work Angle	Inner Angle	Slider Work Stroke (mm)	Press Stroke (mm)	Gas Spring Stroke (mm)
β	α	S	Ps	Gss
0°	50°	38,57	45,96	60
5°	50°	42,59	46,14	60
10°	50°	46,67	46,67	60
15°	50°	50,88	47,58	60
20°	50°	55,30	48,91	60
25°	50°	60,00	50,71	60
30°	50°	65,10	53,07	60
35°	50°	70,75	56,11	60
40°	50°	77,13	60,00	60
45°	50°	84,53	65,00	60
50°	50°	93,34	71,51	60
55°	55°	104,61	85,69	60
60°	60°	120,00	103,92	60

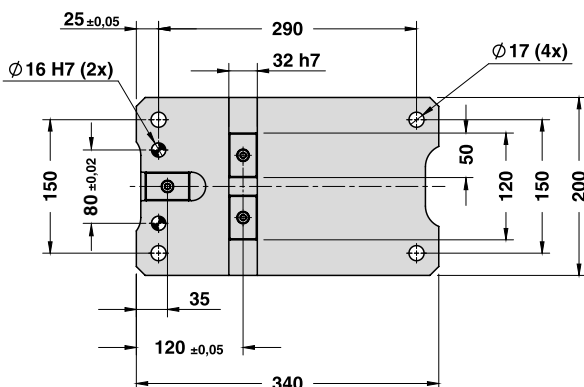



AERIAL CAM UNIT - OBEN HÄNGENDER SCHIEBER - UNITÀ A CAMME SOSPESA

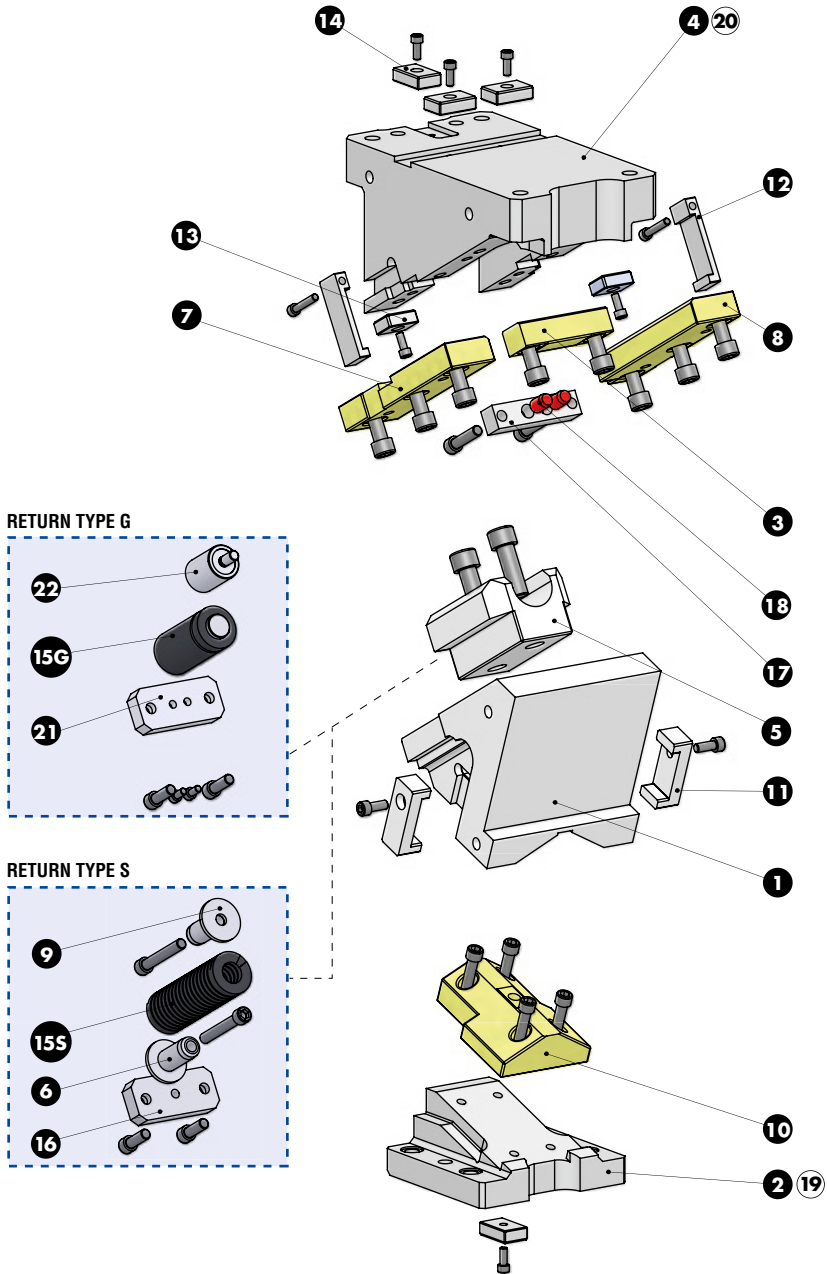

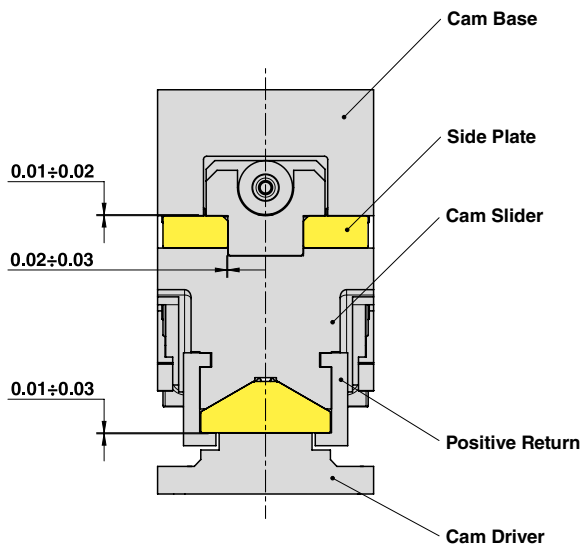

AERIAL CAM UNIT - OBEN HÄNGENDER SCHIEBER - UNITÀ A CAMME SOSPESA
SLIDER STRUCTURE, POSITIVE RETURN STRUCTURE AND CLEARANCES

PART LIST

Particular number	Description	Material	Quantity
1	Cam Slider	GG-30	1
2	Cam Driver	GG-30	1
3	Plate	CuZn25Al5 + Graphite - HB > 190	1
4	Cam Base	GG-30	1
5	Spring Guide Block	CK45 + Graphite	1
6	Spring Guide Pin	CK45	2
7	Side Plate L	CuZn25Al5 + Graphite - HB > 190	1
8	Side Plate R	CuZn25Al5 + Graphite - HB > 190	1
9	Washer	CK45	2
10	Male "V" Driver	CuZn25Al5 + Graphite - HB > 190	1
11	Positive Return	42CrMo4 Nitrided	2
12	Positive Return	CK45	2
13	Key	CK45	2
14	Key	CK45	4
15G	Gas Spring - Return Type G	-	1
15S	Spring - Return Type S	-	1
19	Cam Driver Fixing Screws M16x60 DIN 912	-	4
20	Cam Base Fixing Screws M16x65 DIN 912	-	4
21	Gas Spring Stopper Plate	CK45	1
22	Gas Spring Reaction	CK45	1

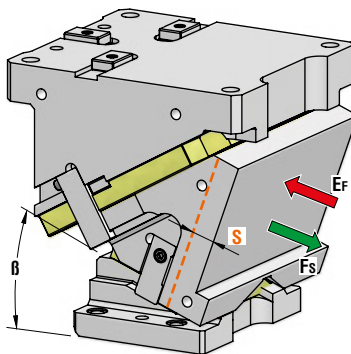

AERIAL CAM UNIT - OBEN HÄNGENDER SCHIEBER - UNITÀ A CAMME SOSPESA



P.605

OMCR CODE	Work Angle β	Stroke (mm) S	Max Work Force with shoulder (kN) F_s	Extraction Force (kN) E_f	
				Spring	Gas Spring
CLB300.00	0°	38,57	411	5,46	22,83
CLB300.05	5°	42,59	411	5,46	22,83
CLB300.10	10°	46,67	411	5,46	22,83
CLB300.15	15°	50,88	411	5,46	22,83
CLB300.20	20°	55,30	411	5,46	22,83
CLB300.25	25°	60	411	5,46	22,83
CLB300.30	30°	65,10	411	5,46	22,83
CLB300.35	35°	70,75	411	5,46	22,83
CLB300.40	40°	77,13	411	5,46	22,83
CLB300.45	45°	84,53	411	5,46	22,83
CLB300.50	50°	93,34	411	5,46	22,83
CLB300.55	55°	104,61	411	4,25	17,76
CLB300.60	60°	120	411	4,25	17,76

Return Type: **G** = Gas Spring / **S** = Spring



Art.	Work Angle = 5°	Return type
CLB300	05	G

OMCR CODE	Work Angle β	Overall Dimensions (mm)			
		A	B	C	D
CLB300.00	0°	313	58	138	328
CLB300.05	5°	320,64	64,34	125	315
CLB300.10	10°	331,08	72,47	115	305
CLB300.15	15°	336,17	82,37	100	290
CLB300.20	20°	340,76	94	85	275
CLB300.25	25°	344,69	102,32	70	260
CLB300.30	30°	347,83	112,25	55	245
CLB300.35	35°	355,03	123,73	45	235
CLB300.40	40°	351,17	136,66	25	215
CLB300.45	45°	356,12	150,95	15	205
CLB300.50	50°	348,77	161,49	-6	184
CLB300.55	55°	352,01	178,16	-15	175
CLB300.60	60°	332,75	195,83	-45	145



AERIAL CAM UNIT - OBEN HÄNGENDER SCHIEBER - UNITÀ A CAMME SOSPESA

X VIEW

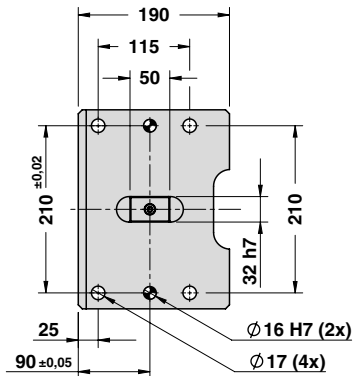
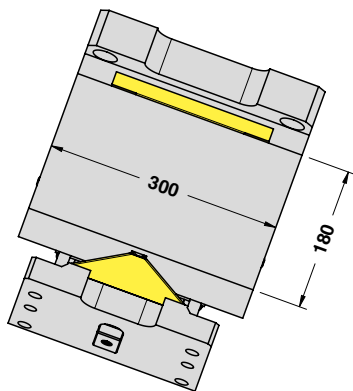

CAM DIAGRAM

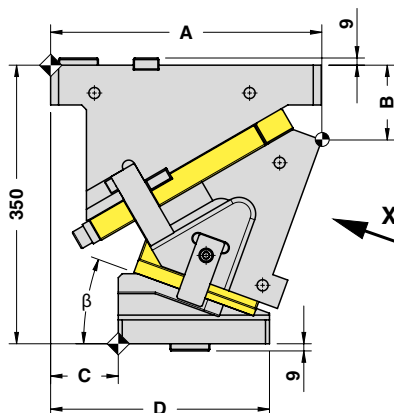
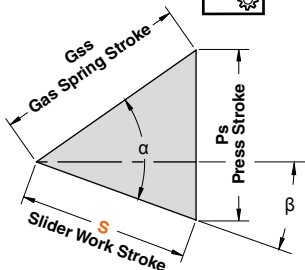

Work Angle	Inner Angle	Slider Work Stroke (mm)	Press Stroke (mm)	Gas Spring Stroke (mm)
β	α	S	Ps	Gss
0°	50°	38,57	45,96	60
5°	50°	42,59	46,14	60
10°	50°	46,67	46,67	60
15°	50°	50,88	47,58	60
20°	50°	55,30	48,91	60
25°	50°	60,00	50,71	60
30°	50°	65,10	53,07	60
35°	50°	70,75	56,11	60
40°	50°	77,13	60,00	60
45°	50°	84,53	65,00	60
50°	50°	93,34	71,51	60
55°	55°	104,61	85,69	60
60°	60°	120,00	103,92	60

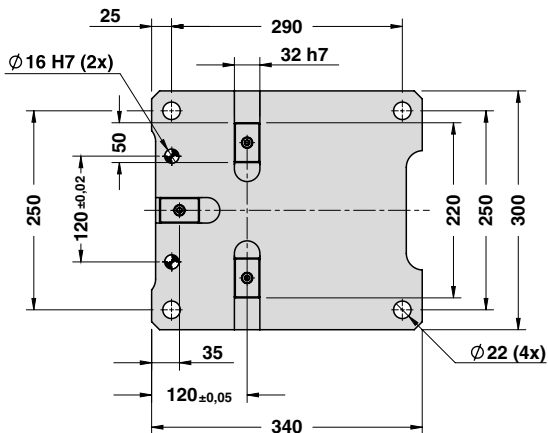



AERIAL CAM UNIT - OBEN HÄNGENDER SCHIEBER - UNITÀ A CAMME SOSPESA

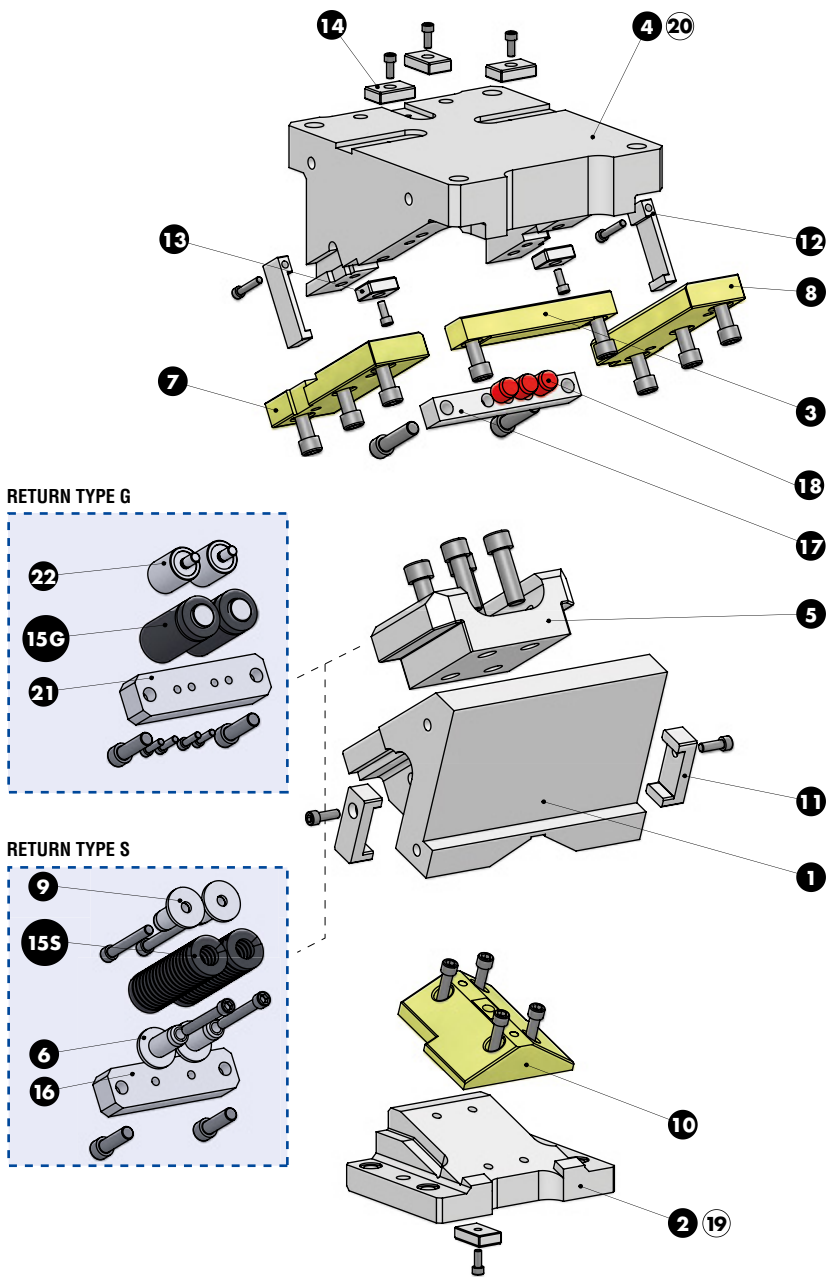

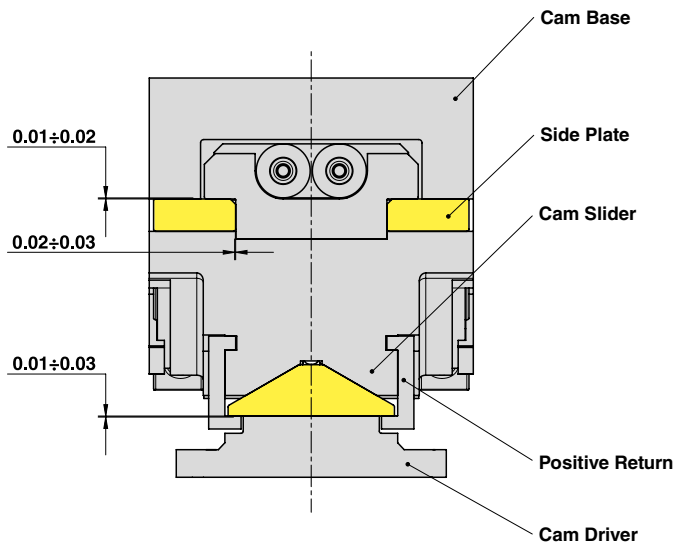

AERIAL CAM UNIT - OBEN HÄNGENDER SCHIEBER - UNITÀ A CAMME SOSPESA
SLIDER STRUCTURE, POSITIVE RETURN STRUCTURE AND CLEARANCES

PART LIST

Particular number	Description	Material	Quantity
1	Cam Slider	GG-30	1
2	Cam Driver	GG-30	1
3	Plate	CuZn25Al5 + Graphite - HB > 190	1
4	Cam Base	GG-30	1
5	Spring Guide Block	CK45 + Graphite	1
6	Spring Guide Pin	CK45	4
7	Side Plate L	CuZn25Al5 + Graphite - HB > 190	1
8	Side Plate R	CuZn25Al5 + Graphite - HB > 190	1
9	Washer	CK45	4
10	Male "V" Driver	CuZn25Al5 + Graphite - HB > 190	1
11	Positive Return	42CrMo4 Nitrided	2
12	Positive Return	CK45	2
13	Key	CK45	2
14	Key	CK45	4
15G	Gas Spring - Return Type G	-	1
15S	Spring - Return Type S	-	1
16	Spring Stopper Plate	CK45	1
17	Stopper Plate	CK45	1
18	Elastomer Cap	Elastomer 92SH	3
19	Cam Driver Fixing Screws M16x60 DIN 912	-	4
20	Cam Base Fixing Screws M20x75 DIN 912	-	4
21	Gas Spring Stopper Plate	CK45	2
22	Gas Spring Reaction	CK45	2

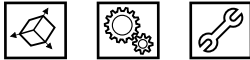
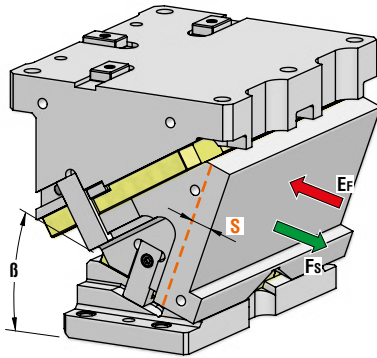

AERIAL CAM UNIT - OBEN HÄNGENDER SCHIEBER - UNITÀ A CAMME SOSPESA



P.605

OMCR CODE	Work Angle β	Stroke (mm) S	Max Work Force with shoulder (kN) F_s	Extraction Force (kN) E_F	
				Spring	Gas Spring
CLB400.00	0°	38,57	526	5,46	22,83
CLB400.05	5°	42,59	526	5,46	22,83
CLB400.10	10°	46,67	526	5,46	22,83
CLB400.15	15°	50,88	526	5,46	22,83
CLB400.20	20°	55,30	526	5,46	22,83
CLB400.25	25°	60	526	5,46	22,83
CLB400.30	30°	65,10	526	5,46	22,83
CLB400.35	35°	70,75	526	5,46	22,83
CLB400.40	40°	77,13	526	5,46	22,83
CLB400.45	45°	84,53	526	5,46	22,83
CLB400.50	50°	93,34	526	5,46	22,83
CLB400.55	55°	104,61	526	4,25	17,76
CLB400.60	60°	120	526	4,25	17,76

Return Type: G = Gas Spring / S = Spring



Art.	Work Angle = 5°	Return type
CLB400	05	S

OMCR CODE	Work Angle β	Overall Dimensions (mm)			
		A	B	C	D
CLB400.00	0°	313	58	138	328
CLB400.05	5°	320,64	64,34	125	315
CLB400.10	10°	331,08	72,47	115	305
CLB400.15	15°	336,17	82,37	100	290
CLB400.20	20°	340,76	94	85	275
CLB400.25	25°	344,69	102,32	70	260
CLB400.30	30°	347,83	112,25	55	245
CLB400.35	35°	355,03	123,73	45	235
CLB400.40	40°	351,17	136,66	25	215
CLB400.45	45°	356,12	150,95	15	205
CLB400.50	50°	348,77	161,49	-6	184
CLB400.55	55°	352,01	178,16	-15	175
CLB400.60	60°	332,75	195,83	-45	145



AERIAL CAM UNIT - OBEN HÄNGENDER SCHIEBER - UNITÀ A CAMME SOSPESA

X VIEW

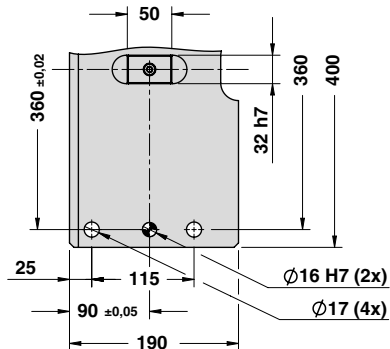
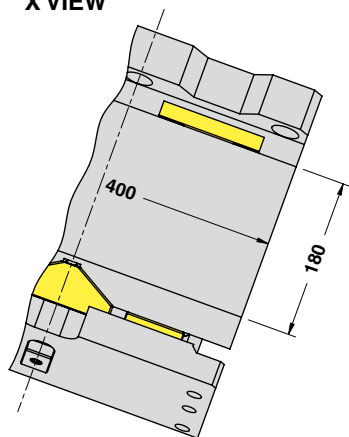

CAM DIAGRAM

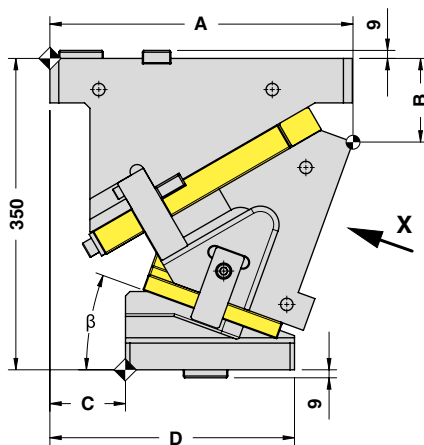
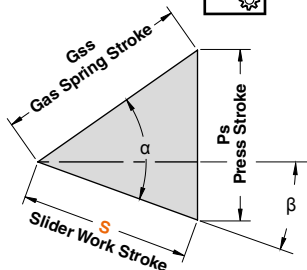

Work Angle	Inner Angle	Slider Work Stroke (mm)	Press Stroke (mm)	Gas Spring Stroke (mm)
β	α	S	Ps	Gss
0°	50°	38,57	45,96	60
5°	50°	42,59	46,14	60
10°	50°	46,67	46,67	60
15°	50°	50,88	47,58	60
20°	50°	55,30	48,91	60
25°	50°	60	50,71	60
30°	50°	65,10	53,07	60
35°	50°	70,75	56,11	60
40°	50°	77,13	60	60
45°	50°	84,53	65	60
50°	50°	93,34	71,51	60
55°	55°	104,61	85,69	60
60°	60°	120,00	103,92	60

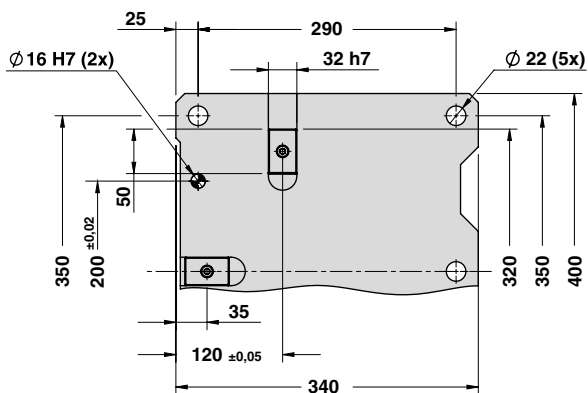



AERIAL CAM UNIT - OBEN HÄNGENDER SCHIEBER - UNITÀ A CAMME SOSPESA

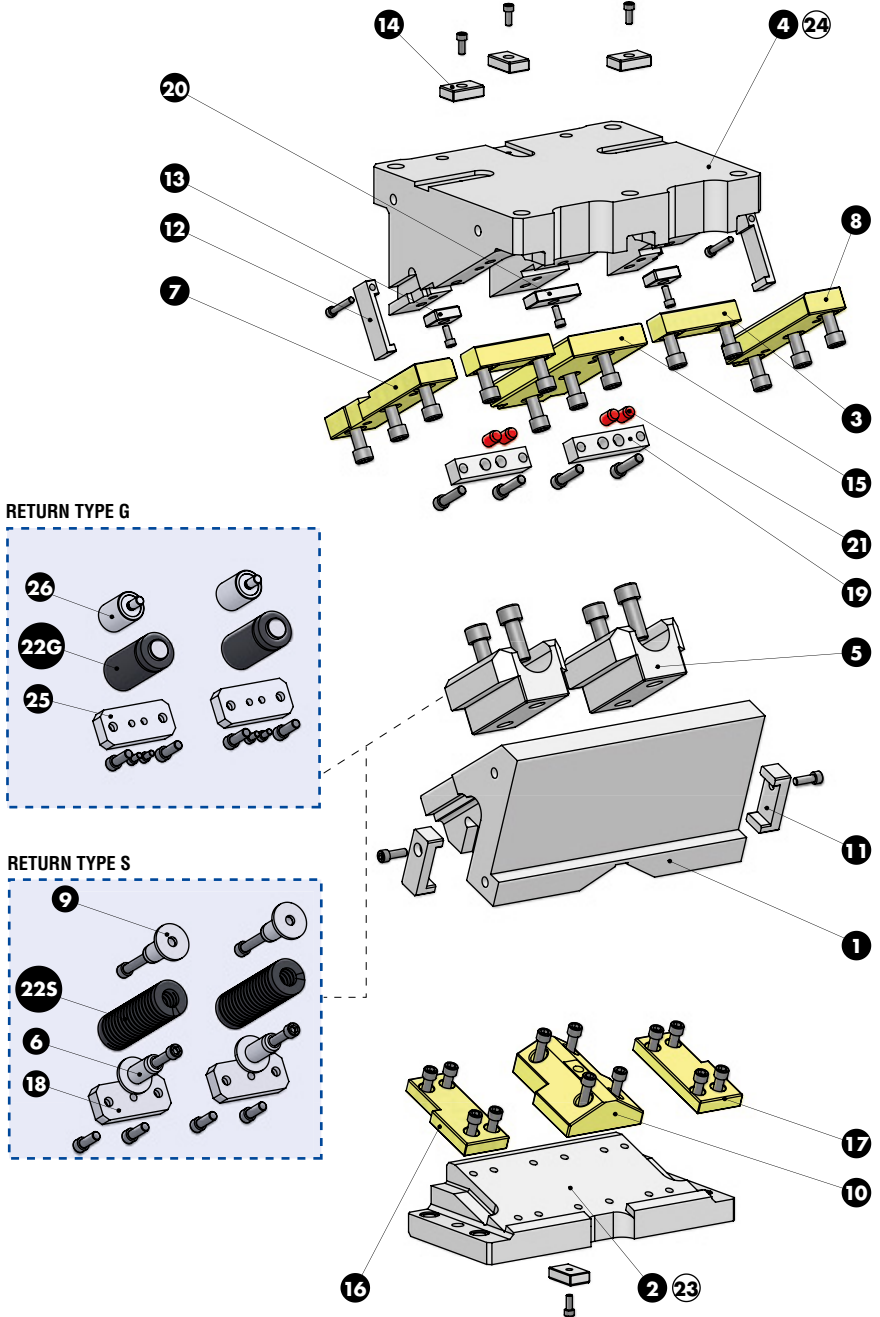

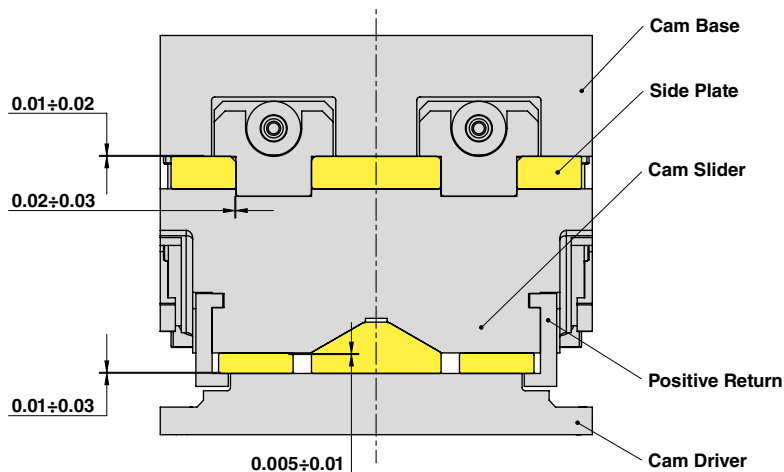

AERIAL CAM UNIT - OBEN HÄNGENDER SCHIEBER - UNITÀ A CAMME SOSPESA
SLIDER STRUCTURE, POSITIVE RETURN STRUCTURE AND CLEARANCES

PART LIST

Particular number	Description	Material	Quantity
1	Cam Slider	GG-30	1
2	Cam Driver	GG-30	1
3	Plate	CuZn25Al5 + Graphite - HB > 190	2
4	Cam Base	GG-30	1
5	Spring Guide Block	CK45 + Graphite	2
6	Spring Guide Pin	CK45	4
7	Side Plate L	CuZn25Al5 + Graphite - HB > 190	1
8	Side Plate R	CuZn25Al5 + Graphite - HB > 190	1
9	Washer	CK45	4
10	Male "V" Driver	CuZn25Al5 + Graphite - HB > 190	1
11	Positive Return	42CrMo4 Nitrided	2
12	Positive Return	CK45	2
13	Key	CK45	2
14	Key	CK45	4
15	Wear Plate	CuZn25Al5 + Graphite - HB > 190	1
16	Wear Plate L	CuZn25Al5 + Graphite - HB > 190	1
17	Wear Plate R	CuZn25Al5 + Graphite - HB > 190	1
18	Spring Stopper Plate	CK45	2
19	Stopper Plate	CK45	2
20	Key	CK45	1
21	Elastomer Cap	Elastomer 92SH	4
22G	Gas Spring - Return Type G	-	2
22S	Spring - Return Type S	-	2
23	Cam Driver Fixing Screws M16x60 DIN 912	-	4
24	Cam Base Fixing Screws M20x75 DIN 912	-	5
25	Gas Spring Stopper Plate	CK45	2
26	Gas Spring Reaction	CK45	2

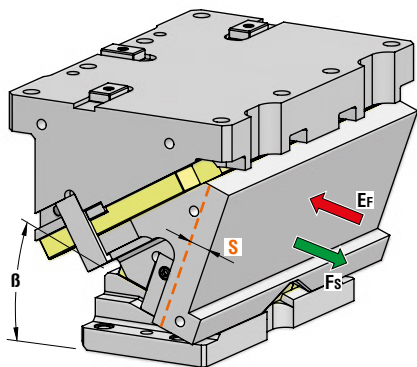

AERIAL CAM UNIT - OBEN HÄNGENDER SCHIEBER - UNITÀ A CAMME SOSPESA



P.605

OMCR CODE	Work Angle β	Stroke (mm) S	Max Work Force with shoulder (kN) F_s	Extraction Force (kN) E_f	
				Spring	Gas Spring
CLB500.00	0°	38,57	743	8,19	34,25
CLB500.05	5°	42,59	743	8,19	34,25
CLB500.10	10°	46,67	743	8,19	34,25
CLB500.15	15°	50,88	743	8,19	34,25
CLB500.20	20°	55,30	743	8,19	34,25
CLB500.25	25°	60	743	8,19	34,25
CLB500.30	30°	65,10	743	8,19	34,25
CLB500.35	35°	70,75	743	8,19	34,25
CLB500.40	40°	77,13	743	8,19	34,25
CLB500.45	45°	84,53	743	8,19	34,25
CLB500.50	50°	93,34	743	8,19	34,25
CLB500.55	55°	104,61	743	6,37	26,64
CLB500.60	60°	120	743	6,37	26,64

Return Type: **G** = Gas Spring / **S** = Spring



Art.	Work Angle = 5°	Return type
CLB500	05	G

OMCR CODE	Work Angle β	Overall Dimensions (mm)			
		A	B	C	D
CLB500.00	0°	313	58	138	328
CLB500.05	5°	320,64	64,34	125	315
CLB500.10	10°	331,08	72,47	115	305
CLB500.15	15°	336,17	82,37	100	290
CLB500.20	20°	340,76	94	85	275
CLB500.25	25°	344,69	102,32	70	260
CLB500.30	30°	347,83	112,25	55	245
CLB500.35	35°	355,03	123,73	45	235
CLB500.40	40°	351,17	136,66	25	215
CLB500.45	45°	356,12	150,95	15	205
CLB500.50	50°	348,77	161,49	-6	184
CLB500.55	55°	352,01	178,16	-15	175
CLB500.60	60°	332,75	195,83	-45	145





AERIAL CAM UNIT - OBEN HÄNGENDER SCHIEBER - UNITÀ A CAMME SOSPESA

X VIEW

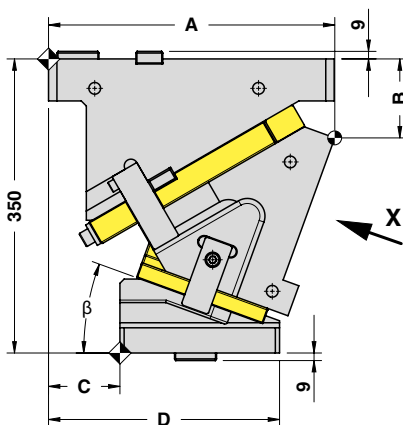
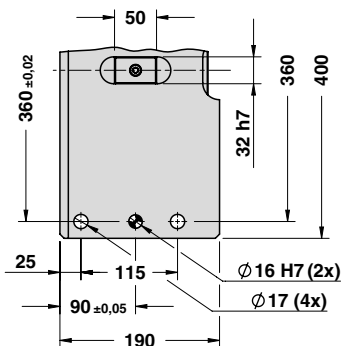
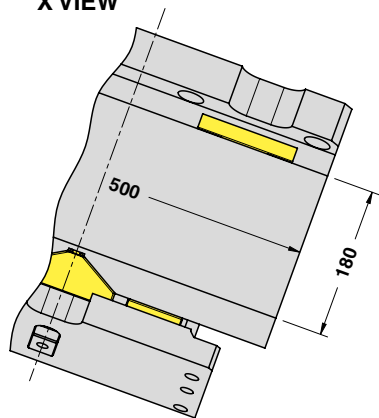

CAM DIAGRAM

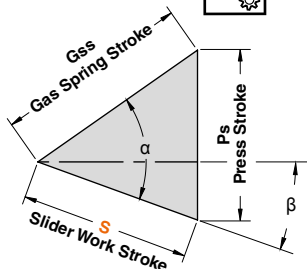

Work Angle	Inner Angle	Slider Work Stroke (mm)	Press Stroke (mm)	Gas Spring Stroke (mm)
β	α	S	Ps	Gss
0°	50°	38,57	45,96	60
5°	50°	42,59	46,14	60
10°	50°	46,67	46,67	60
15°	50°	50,88	47,58	60
20°	50°	55,30	48,91	60
25°	50°	60,00	50,71	60
30°	50°	65,10	53,07	60
35°	50°	70,75	56,11	60
40°	50°	77,13	60,00	60
45°	50°	84,53	65,00	60
50°	50°	93,34	71,51	60
55°	55°	104,61	85,69	60
60°	60°	120,00	103,92	60

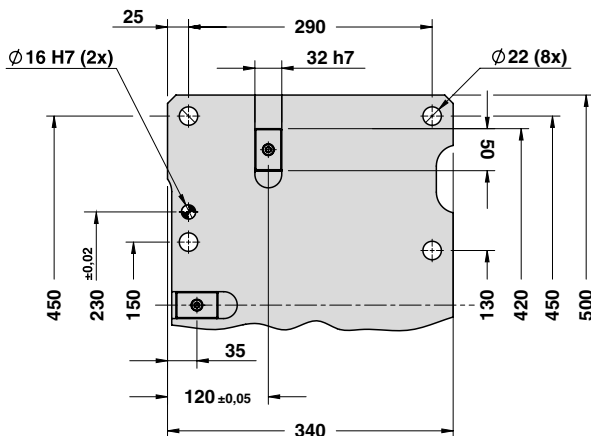

Cam Units CLB



AERIAL CAM UNIT - OBEN HÄNGENDER SCHIEBER - UNITÀ A CAMME SOSPESA

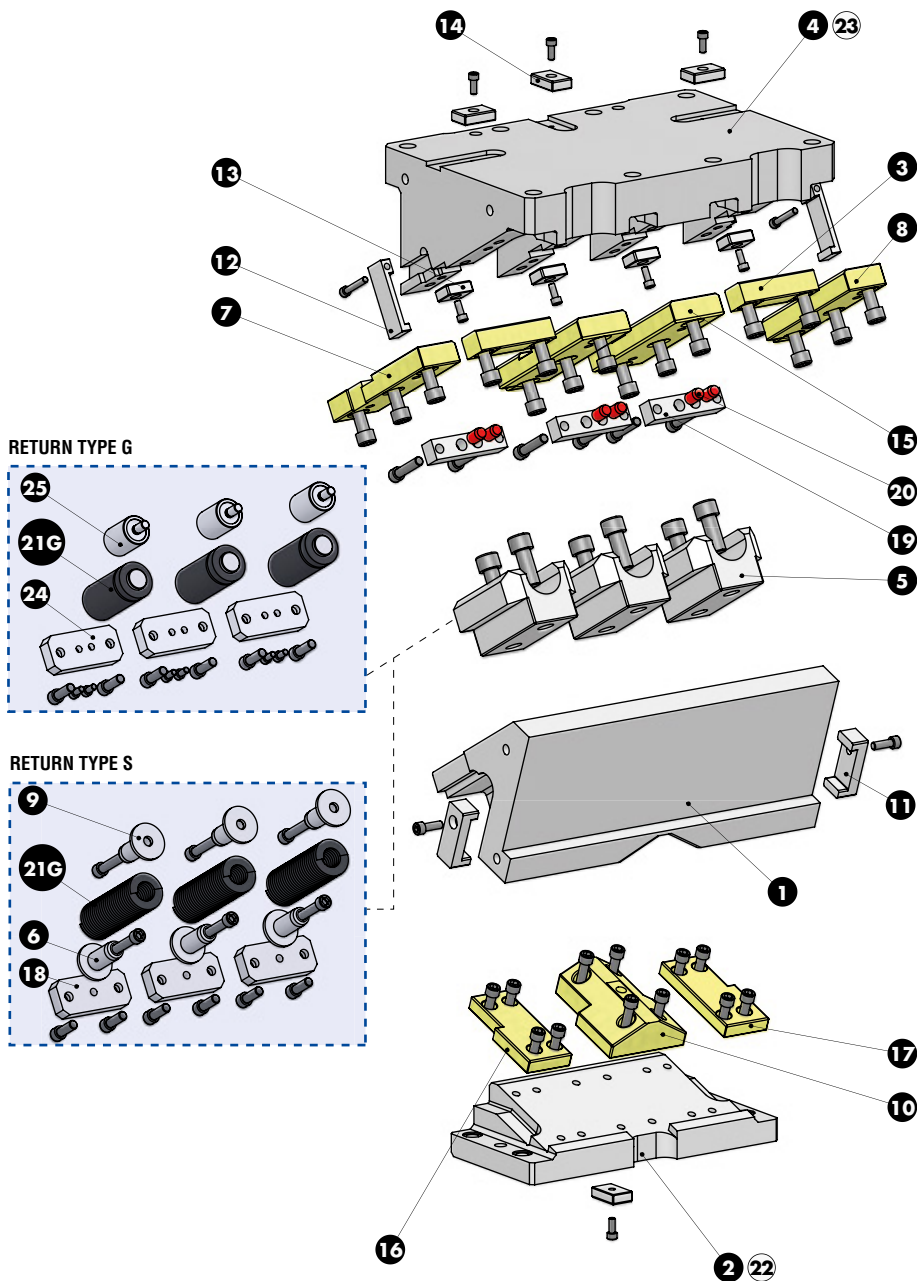



AERIAL CAM UNIT - OBEN HÄNGENDER SCHIEBER - UNITÀ A CAMME SOSPESA

SLIDER STRUCTURE, POSITIVE RETURN STRUCTURE AND CLEARANCES

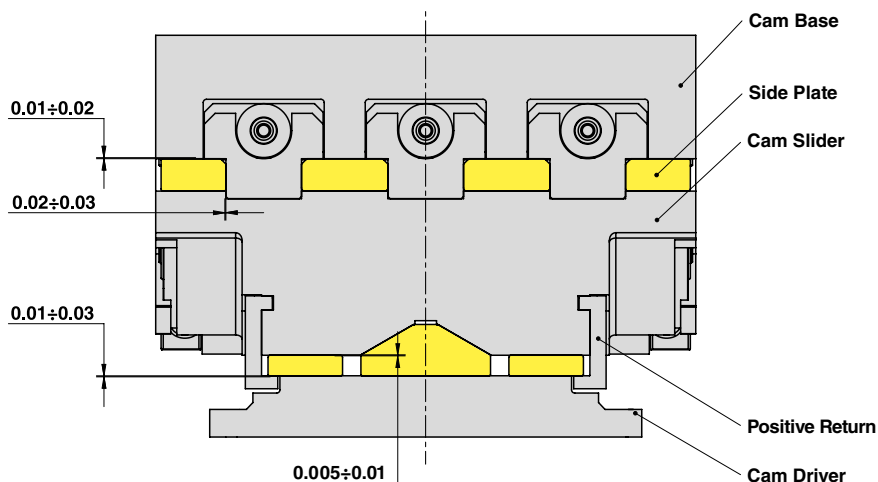

PART LIST

Particular number	Description	Material	Quantity
1	Cam Slider	GG-30	1
2	Cam Driver	GG-30	1
3	Plate	CuZn25Al5 + Graphite - HB > 190	2
4	Cam Base	GG-30	1
5	Spring Guide Block	CK45 + Graphite	3
6	Spring Guide Pin	CK45	6
7	Side Plate L	CuZn25Al5 + Graphite - HB > 190	1
8	Side Plate R	CuZn25Al5 + Graphite - HB > 190	1
9	Washer	CK45	6
10	Male "V" Driver	CuZn25Al5 + Graphite - HB > 190	1
11	Positive Return	42CrMo4 Nitrided	2
12	Positive Return	CK45	2
13	Key	CK45	4
14	Key	CK45	4
15	Wear Plate	CuZn25Al5 + Graphite - HB > 190	2
16	Wear Plate L	CuZn25Al5 + Graphite - HB > 190	1
17	Wear Plate R	CuZn25Al5 + Graphite - HB > 190	1
18	Spring Stopper Plate	CK45	3
19	Stopper Plate	CK45	3
20	Elastomer Cap	Elastomer 92SH	6
21G	Gas Spring - Return Type G	-	3
21S	Spring - Return Type S	-	3
22	Cam Driver Fixing Screws M16x60 DIN 912	-	4
23	Cam Base Fixing Screws M20x75 DIN 912	-	8
24	Gas Spring Stopper Plate	CK45	3
25	Gas Spring Reaction	CK45	3



AERIAL CAM UNIT - OBEN HÄNGENDER SCHIEBER - UNITÀ A CAMME SOSPESA

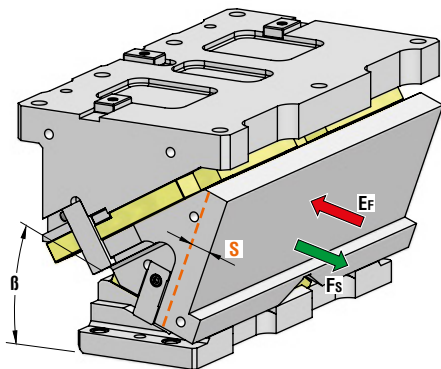

P.605

OMCR CODE	Work Angle	Stroke (mm)	Max Work Force with shoulder (kN)	Extraction Force (kN)	
				EF	
	β	S	Fs	Spring	Gas Spring
CLB600.00	0°	38,57	865	10,92	45,67
CLB600.05	5°	42,59	865	10,92	45,67
CLB600.10	10°	46,67	865	10,92	45,67
CLB600.15	15°	50,88	865	10,92	45,67
CLB600.20	20°	55,30	865	10,92	45,67
CLB600.25	25°	60	865	10,92	45,67
CLB600.30	30°	65,10	865	10,92	45,67
CLB600.35	35°	70,75	865	10,92	45,67
CLB600.40	40°	77,13	865	10,92	45,67
CLB600.45	45°	84,53	865	10,92	45,67
CLB600.50	50°	93,34	865	10,92	45,67
CLB600.55	55°	104,61	865	8,50	35,52
CLB600.60	60°	120	865	8,50	35,52

Return Type: G = Gas Spring / S = Spring



Art.	Work Angle = 5°	Return type
CLB600	05	G

OMCR CODE	Work Angle	Overall Dimensions (mm)				
		β	A	B	C	D
CLB600.00	0°		313	58	138	328
CLB600.05	5°		320,64	64,34	125	315
CLB600.10	10°		331,08	72,47	115	305
CLB600.15	15°		336,17	82,37	100	290
CLB600.20	20°		340,76	94	85	275
CLB600.25	25°		344,69	102,32	70	260
CLB600.30	30°		347,83	112,25	55	245
CLB600.35	35°		355,03	123,73	45	235
CLB600.40	40°		351,17	136,66	25	215
CLB600.45	45°		356,12	150,95	15	205
CLB600.50	50°		348,77	161,49	-6	184
CLB600.55	55°		352,01	178,16	-15	175
CLB600.60	60°		332,75	195,83	-45	145



AERIAL CAM UNIT - OBEN HÄNGENDER SCHIEBER - UNITÀ A CAMME SOSPESA

X VIEW

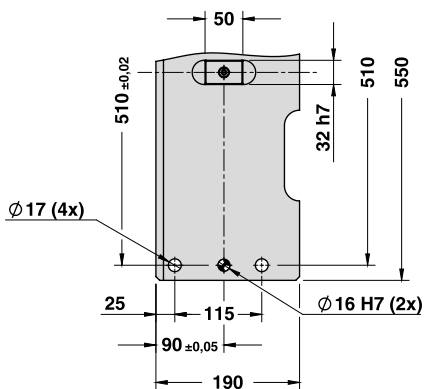
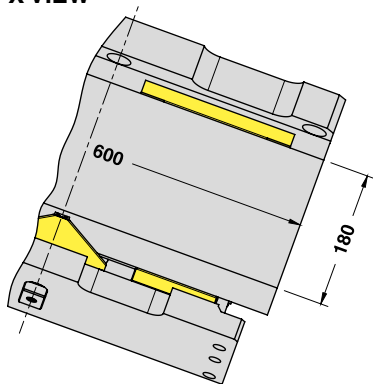

CAM DIAGRAM

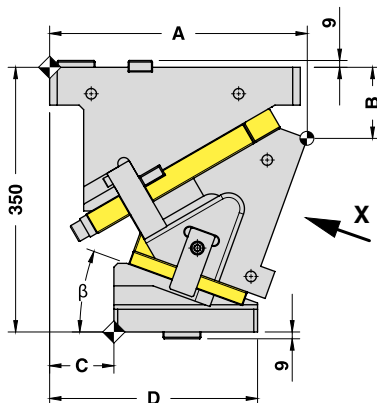
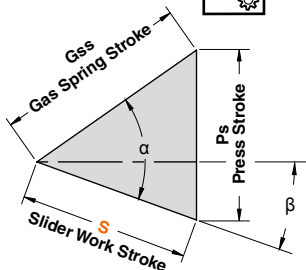

Work Angle	Inner Angle	Slider Work Stroke (mm)	Press Stroke (mm)	Gas Spring Stroke (mm)
β	α	S	Ps	Gss
0°	50°	38,57	45,96	60
5°	50°	42,59	46,14	60
10°	50°	46,67	46,67	60
15°	50°	50,88	47,58	60
20°	50°	55,30	48,91	60
25°	50°	60,00	50,71	60
30°	50°	65,10	53,07	60
35°	50°	70,75	56,11	60
40°	50°	77,13	60,00	60
45°	50°	84,53	65,00	60
50°	50°	93,34	71,51	60
55°	55°	104,61	85,69	60
60°	60°	120,00	103,92	60

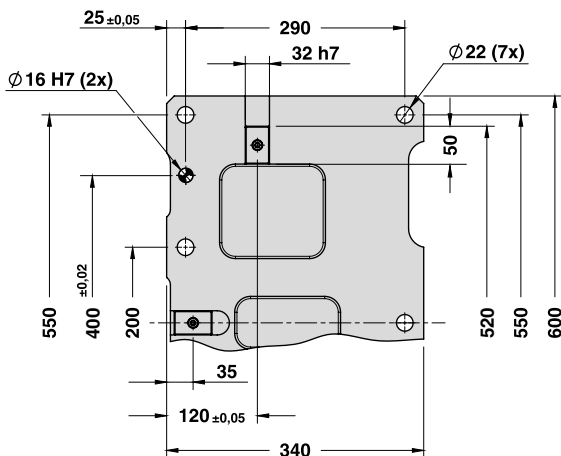



AERIAL CAM UNIT - OBEN HÄNGENDER SCHIEBER - UNITÀ A CAMME SOSPESA

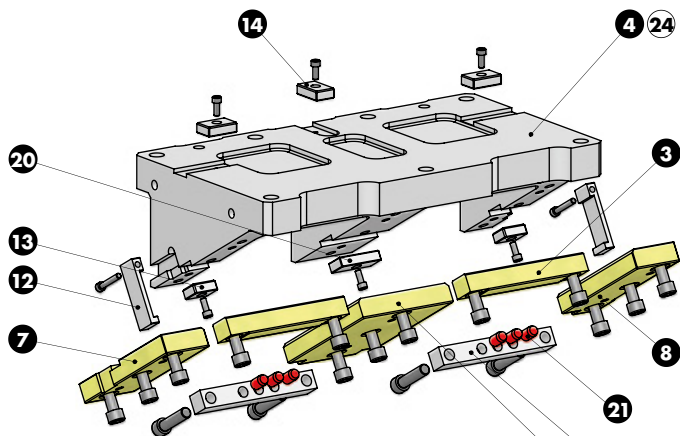

RETURN TYPE G

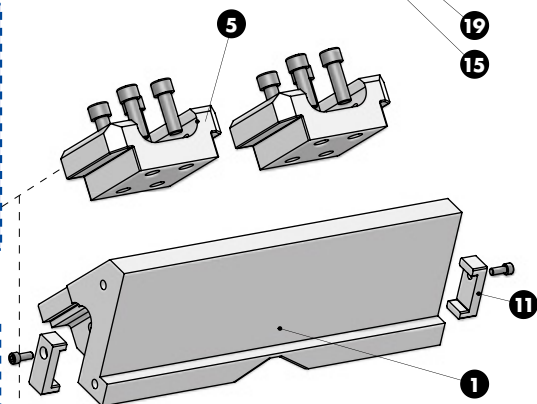
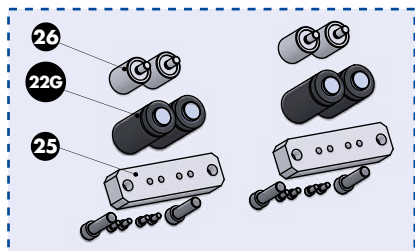

RETURN TYPE S

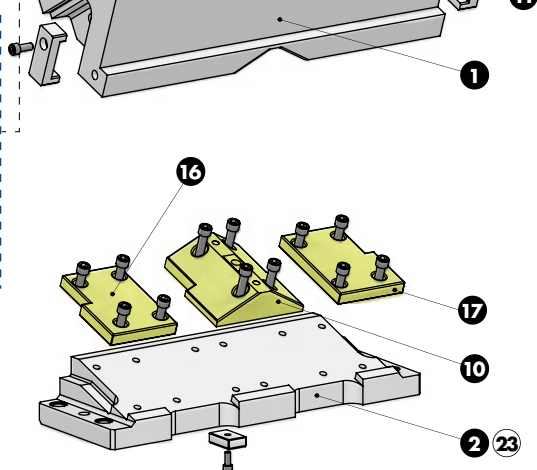
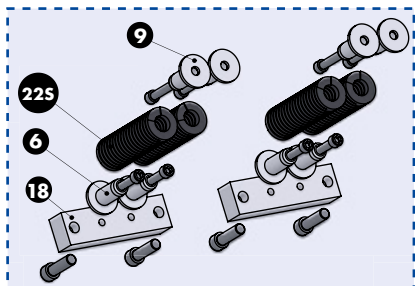



AERIAL CAM UNIT - OBEN HÄNGENDER SCHIEBER - UNITÀ A CAMME SOSPESA

SLIDER STRUCTURE, POSITIVE RETURN STRUCTURE AND CLEARANCES

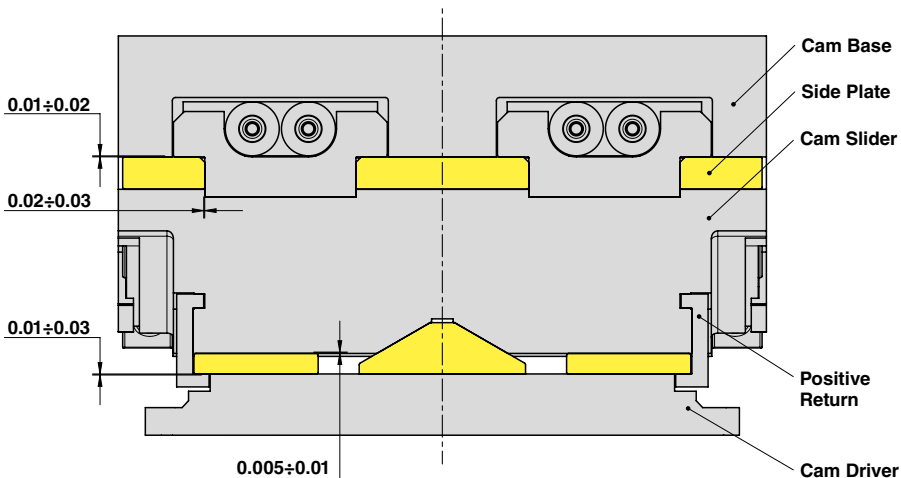

PART LIST

Particular number	Description	Material	Quantity
1	Cam Slider	GG-30	1
2	Cam Driver	GG-30	1
3	Plate	CuZn25Al5 + Graphite - HB > 190	2
4	Cam Base	GG-30	1
5	Spring Guide Block	CK45 + Graphite	2
6	Spring Guide Pin	CK45	8
7	Side Plate L	CuZn25Al5 + Graphite - HB > 190	1
8	Side Plate R	CuZn25Al5 + Graphite - HB > 190	1
9	Washer	CK45	8
10	Male "V" Driver	CuZn25Al5 + Graphite - HB > 190	1
11	Positive Return	42CrMo4 Nitrided	2
12	Positive Return	CK45	2
13	Key	CK45	2
14	Key	CK45	4
15	Wear Plate	CuZn25Al5 + Graphite - HB > 190	1
16	Wear Plate L	CuZn25Al5 + Graphite - HB > 190	1
17	Wear Plate R	CuZn25Al5 + Graphite - HB > 190	1
18	Spring Stopper Plate	CK45	2
19	Stopper Plate	CK45	2
20	Key	CK45	1
21	Elastomer Cap	Elastomer 92SH	6
22G	Gas Spring - Return Type G	-	4
22S	Spring - Return Type S	-	4
23	Cam Driver Fixing Screws M16x60 DIN 912	-	4
24	Cam Base Fixing Screws M20x75 DIN 912	-	7
25	Gas Spring Stopper Plate	CK45	2
26	Gas Spring Reaction	CK45	4