



Cam Units CHK
Schieber CHK
Unità a Camme CHK

MCR[®]
STANDARD DIE COMPONENTS

2018.01

OMCR CODE	Work Angle	Slider Width (mm)	Closed Cam Height (mm)	Work Area W x H (mm)	Max Work Force with shoulder 10 ⁶ cycles (kN)	Extraction Force (kN)	Page number
	β				F _s	E _F	
CHK065	0°÷70° (5° steps)	65	210	65 x "F"	58	0,32÷0,85	648
CHK100	0°÷70° (10° steps)	100	280	100 x "F"	96	0,99÷2,10	652
CHK200	0°÷70° (10° steps)	200	280	200 x "F"	231	1,98÷4,21	656



Advanced production tools

AERIAL CAM UNIT - OBEN HÄNGENDER SCHIEBER - UNITÀ A CAMME SOSPESA

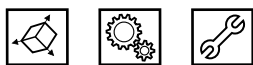
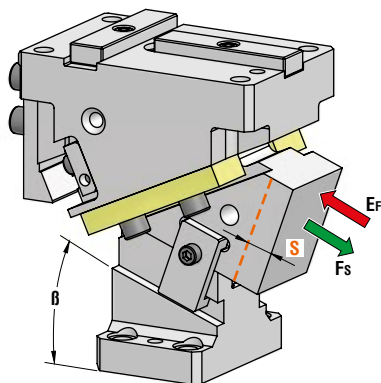

P.605

OMCR CODE	Work Angle β	Stroke (mm) S	Max Work Force with shoulder (kN) F_s	Extraction Force (kN)
				E_f Spring
CHK065.00	0°	26,87	58	0,79
CHK065.05	5°	26,97	58	0,77
CHK065.10	10°	31,61	58	0,85
CHK065.15	15°	32,23	58	0,77
CHK065.20	20°	33,76	58	0,85
CHK065.25	25°	35	58	0,77
CHK065.30	30°	33,46	58	0,85
CHK065.35	35°	35,38	58	0,77
CHK065.40	40°	42,91	58	0,85
CHK065.45	45°	46,49	58	0,77
CHK065.50	50°	54,45	58	0,77
CHK065.55	55°	43,59	58	0,62
CHK065.60	60°	50	58	0,54
CHK065.65	65°	47,32	58	0,39
CHK065.70	70°	58,48	58	0,32



Art.	Work Angle = 5°
CHK065	05

OMCR CODE	Work Angle β	Overall Dimensions (mm)					
		A	B	C	D	E	F
CHK065.00	0°	185,94	56,57	75	155	55	80
CHK065.05	5°	193,01	56,57	70	150	55	90
CHK065.10	10°	196,80	67,58	70	150	40	80
CHK065.15	15°	203,77	68,81	67	147	40	90
CHK065.20	20°	198,10	74,31	60	140	10	80
CHK065.25	25°	204,75	76,73	55	135	10	90
CHK065.30	30°	193,63	89,52	50	130	10	80
CHK065.35	35°	199,76	93,06	45	125	10	90
CHK065.40	40°	188,72	99,62	40	120	15	80
CHK065.45	45°	194,13	104,16	34	114	15	90
CHK065.50	50°	190	110	30	110	10	90
CHK065.55	55°	190	115	20	100	10	100
CHK065.60	60°	190	115	20	100	10	100
CHK065.65	65°	190	130	0	80	10	110
CHK065.70	70°	190	130	0	80	10	110

AERIAL CAM UNIT - OBEN HÄNGENDER SCHIEBER - UNITÀ A CAMME SOSPESA

X VIEW

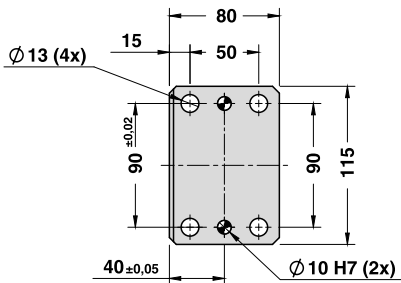
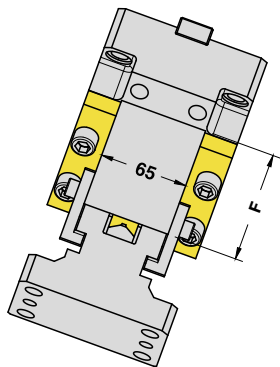

CAM DIAGRAM

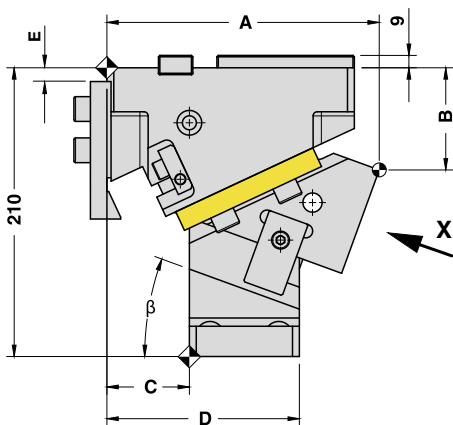
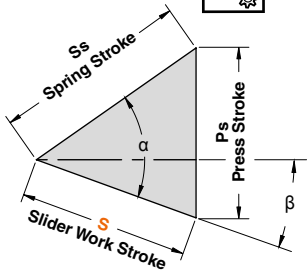

Work Angle	Inner Angle	Slider Work Stroke (mm)	Press Stroke (mm)	Spring Stroke (mm)
β	α	S	Ps	Ss
0°	45°	26,87	26,87	38
5°	50°	26,97	29,22	38
10°	45°	31,61	27,28	38
15°	50°	32,23	30,14	38
20°	45°	33,76	26,34	35
25°	50°	35,00	29,58	35
30°	45°	33,46	24,49	30
35°	50°	35,38	28,06	30
40°	45°	42,91	30,46	33
45°	50°	46,49	35,75	33
50°	50°	54,45	41,71	35
55°	55°	43,59	35,70	25
60°	60°	50,00	43,30	25
65°	65°	47,32	42,89	20
70°	70°	58,48	54,95	20

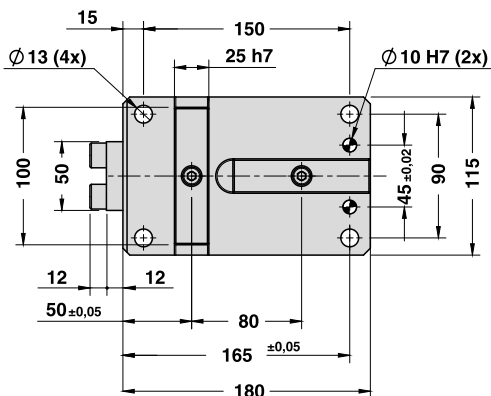

AERIAL CAM UNIT - OBEN HÄNGENDER SCHIEBER - UNITÀ A CAMME SOSPESA

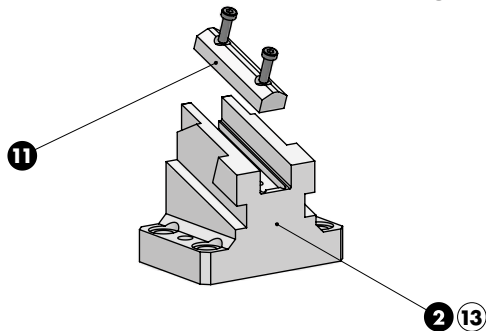
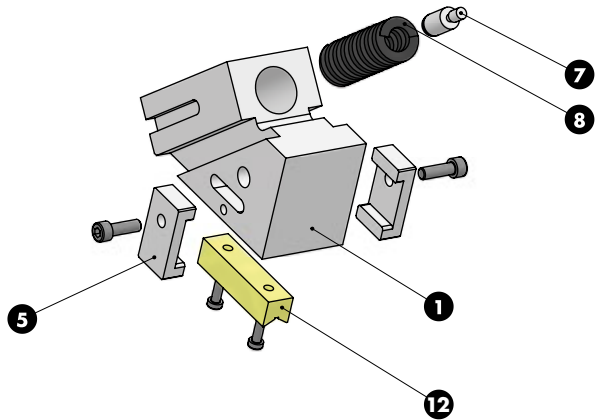
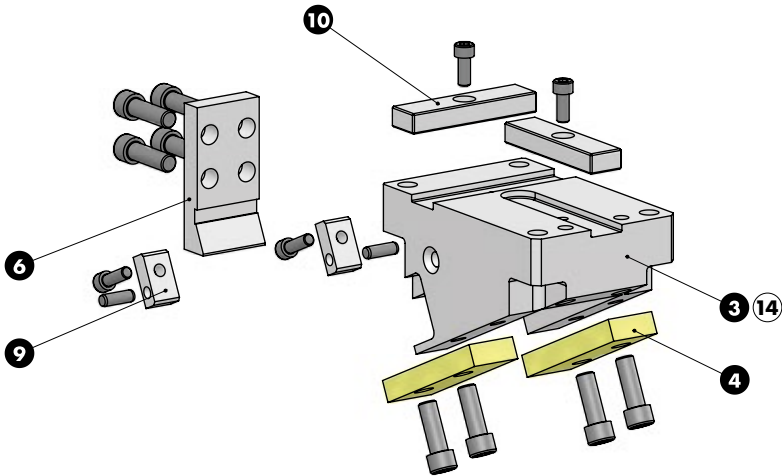

AERIAL CAM UNIT - OBEN HÄNGENDER SCHIEBER - UNITÀ A CAMME SOSPESA

SLIDER STRUCTURE, POSITIVE RETURN STRUCTURE AND CLEARANCES

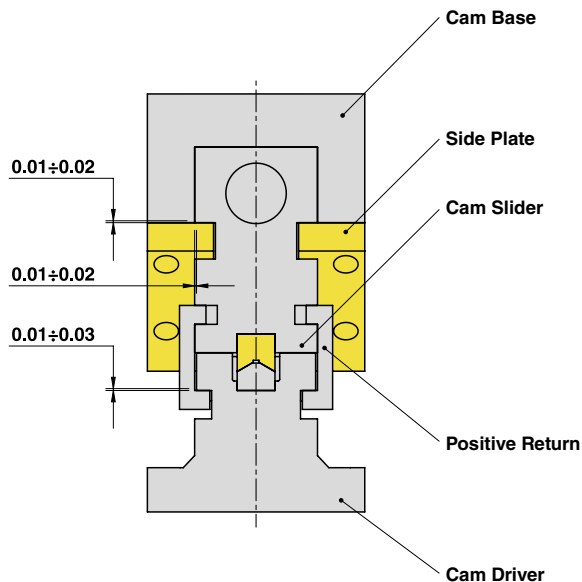

PART LIST

Particular number	Description	Material	Quantity
1	Cam Slider	GG-25 + Graphite	1
2	Cam Driver	GG-25 + Graphite	1
3	Cam Base	GG-25	1
4	Side Plate	CuZn25Al5 + Graphite - HB > 190	2
5	Positive Return	CK45	2
6	Stopper Plate	St44	1
7	Spring Guide Pin	34CrMo4	1
8	Spring	-	1
9	Plate	CK45	2
10	Key	CK45	2
11	Male "V" Driver	CK45	1
12	Female "V" Driver	CuZn25Al5 + Graphite - HB > 190	1
13	Cam Driver Fixing Screws M12x45 DIN 912	-	4
14	Cam Base Fixing Screws M12x55 DIN 912	-	4

AERIAL CAM UNIT - OBEN HÄNGENDER SCHIEBER - UNITÀ A CAMME SOSPESA

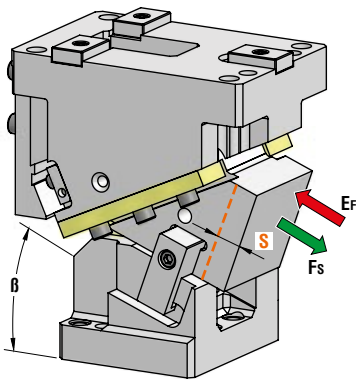

OMCR CODE	Work Angle	Stroke (mm)	Max Work Force with shoulder (kN)	Extraction Force (kN)
	β	S	F _s	E _f
CHK100.00	0°	28,28	96	2,10
CHK100.10	10°	33,27	96	2,10
CHK100.20	20°	30,86	96	1,86
CHK100.30	30°	33,46	96	2,10
CHK100.40	40°	39,01	96	2,10
CHK100.50	50°	46,67	96	1,91
CHK100.60	60°	60	96	1,48
CHK100.70	70°	58,48	96	0,99



P.605



Art.	Work Angle = 10°
CHK100	10

OMCR CODE	Work Angle	Overall Dimensions (mm)								
		β	A	B	C	D	E	F	G	H
CHK100.00	0°	240	85	80	220	55	100	17	140	110
CHK100.10	10°	240	90	60	200	35	100	17	140	110
CHK100.20	20°	240	110	50	190	15	100	18	140	110
CHK100.30	30°	240	110	30	160	10	120	17	130	100
CHK100.40	40°	240	115	30	150	10	120	17	120	90
CHK100.50	50°	240	120	10	130	0	140	16	120	90
CHK100.60	60°	240	145	0	110	0	140	16	110	80
CHK100.70	70°	240	145	0	110	0	140	16	110	80

AERIAL CAM UNIT - OBEN HÄNGENDER SCHIEBER - UNITÀ A CAMME SOSPESA

X VIEW

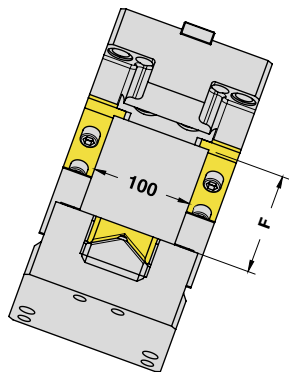

CAM DIAGRAM

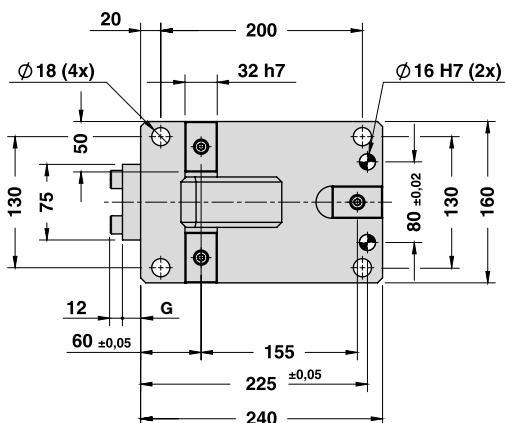
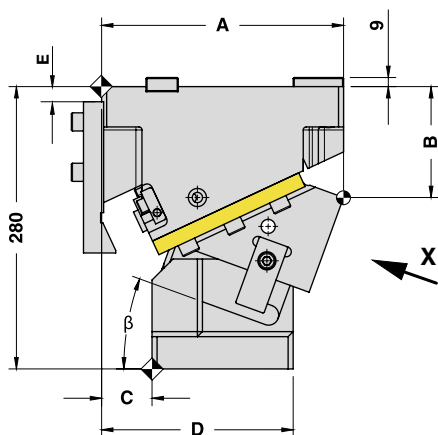
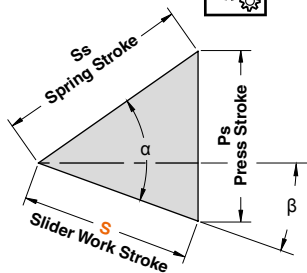

Work Angle	Inner Angle	Slider Work Stroke (mm)	Press Stroke (mm)	Spring Stroke (mm)
β	α	S	Ps	Ss
0°	45°	28,28	28,28	40
10°	45°	33,27	28,72	40
20°	45°	30,86	24,08	32
30°	45°	33,46	24,49	30
40°	45°	39,01	27,69	30
50°	50°	46,67	35,75	30
60°	60°	60,00	51,96	30
70°	70°	58,48	54,95	20

AERIAL CAM UNIT - OBEN HÄNGENDER SCHIEBER - UNITÀ A CAMME SOSPESA

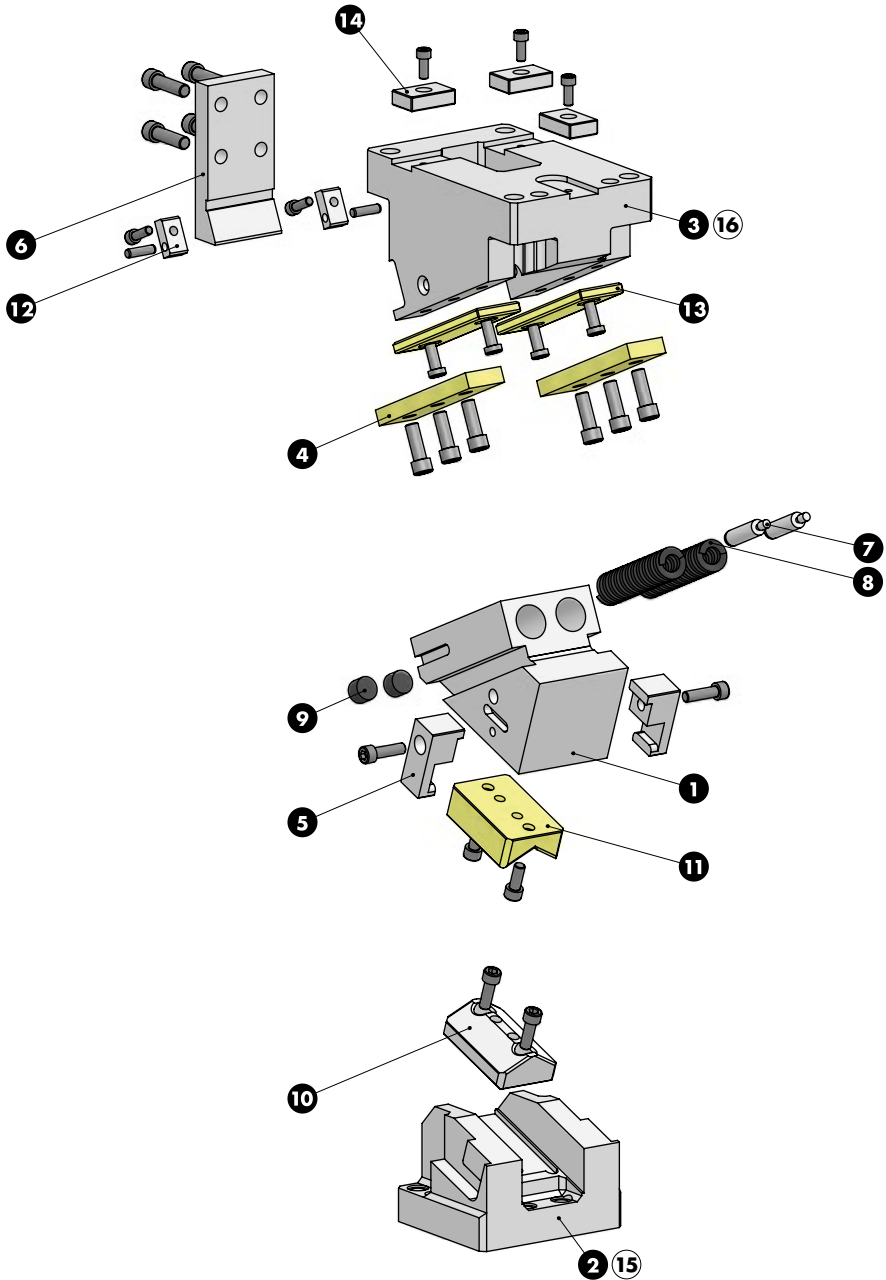

AERIAL CAM UNIT - OBEN HÄNGENDER SCHIEBER - UNITÀ A CAMME SOSPESA

SLIDER STRUCTURE, POSITIVE RETURN STRUCTURE AND CLEARANCES

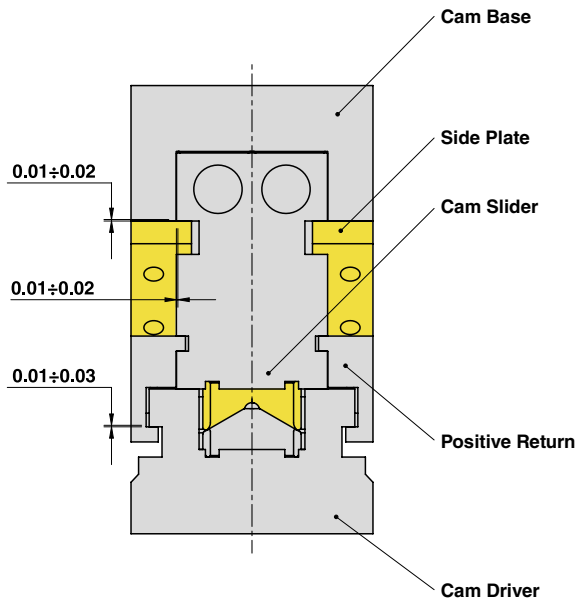

PART LIST

Particular number	Description	Material	Quantity
1	Cam Slider	GGG-25 + Graphite	1
2	Cam Driver	GGG-25 + Graphite	1
3	Cam Base	GGG-25	1
4	Side Plate	CuZn25Al5 + Graphite - HB > 190	2
5	Positive Return	CK45	2
6	Stopper Plate	St44	1
7	Spring Guide Pin	34CrMo4	2
8	Spring	-	2
9	Elastomer Cap	Elastomer 92SH	2
10	Male "V" Driver	CK45	1
11	Female "V" Driver	CuZn25Al5 + Graphite - HB > 190	1
12	Plate	CK45	2
13	Wear Plate	CuZn25Al5 + Graphite - HB > 190	2
14	Key	CK45	3
15	Cam Driver Fixing Screws M12x55 DIN 912	-	4
16	Cam Base Fixing Screws M16x70 DIN 912	-	4

AERIAL CAM UNIT - OBEN HÄNGENDER SCHIEBER - UNITÀ A CAMME SOSPESA

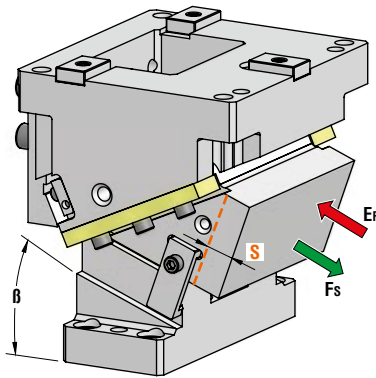

OMCR CODE	Work Angle β	Stroke (mm) S	Max Work Force with shoulder (kN) F_s	Extraction Force (kN)
				E_f Spring
CHK200.00	0°	28,28	231	4,21
CHK200.10	10°	33,27	231	4,21
CHK200.20	20°	30,86	231	3,71
CHK200.30	30°	33,46	231	4,20
CHK200.40	40°	39,01	231	4,20
CHK200.50	50°	46,67	231	3,81
CHK200.60	60°	60	231	2,97
CHK200.70	70°	58,48	231	1,98



P.605



Art.	Work Angle = 10°
CHK200	10

OMCR CODE	Work Angle β	Overall Dimensions (mm)							
		A	B	C	D	E	F	G	H
CHK200.00	0°	240	85	80	190	55	100	17	190
CHK200.10	10°	240	90	60	170	35	100	17	150
CHK200.20	20°	240	110	50	160	15	100	18	150
CHK200.30	30°	240	110	30	140	10	120	17	150
CHK200.40	40°	240	115	30	140	10	120	17	150
CHK200.50	50°	240	120	10	120	0	140	16	150
CHK200.60	60°	240	145	0	110	0	140	16	150
CHK200.70	70°	240	145	0	110	0	140	16	150

AERIAL CAM UNIT - OBEN HÄNGENDER SCHIEBER - UNITÀ A CAMME SOSPESA

X VIEW

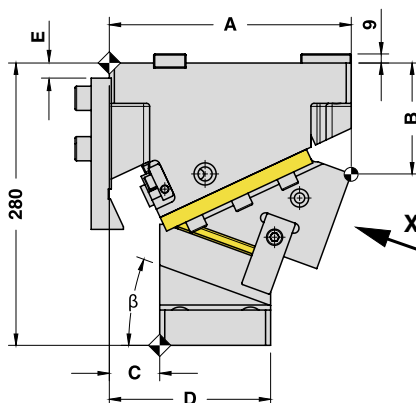
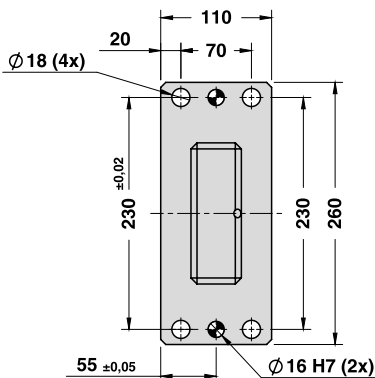
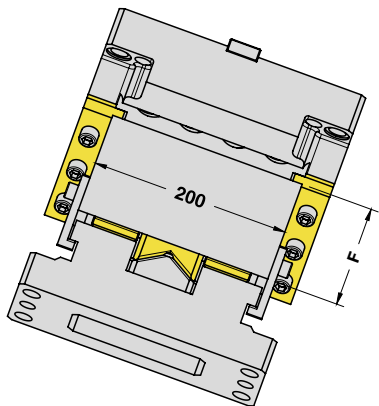

CAM DIAGRAM

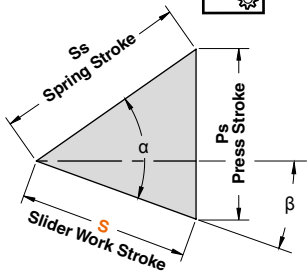

Work Angle	Inner Angle	Slider Work Stroke (mm)	Press Stroke (mm)	Spring Stroke (mm)
β	α	S	Ps	Ss
0°	45°	28,28	28,28	40
10°	45°	33,27	28,72	40
20°	45°	30,86	24,08	32
30°	45°	33,46	24,49	30
40°	45°	39,01	27,69	30
50°	50°	46,67	35,75	30
60°	60°	60,00	51,96	30
70°	70°	58,48	54,95	20

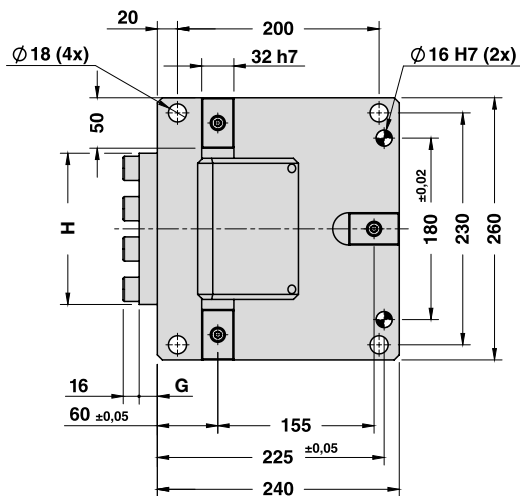

AERIAL CAM UNIT - OBEN HÄNGENDER SCHIEBER - UNITÀ A CAMME SOSPESA

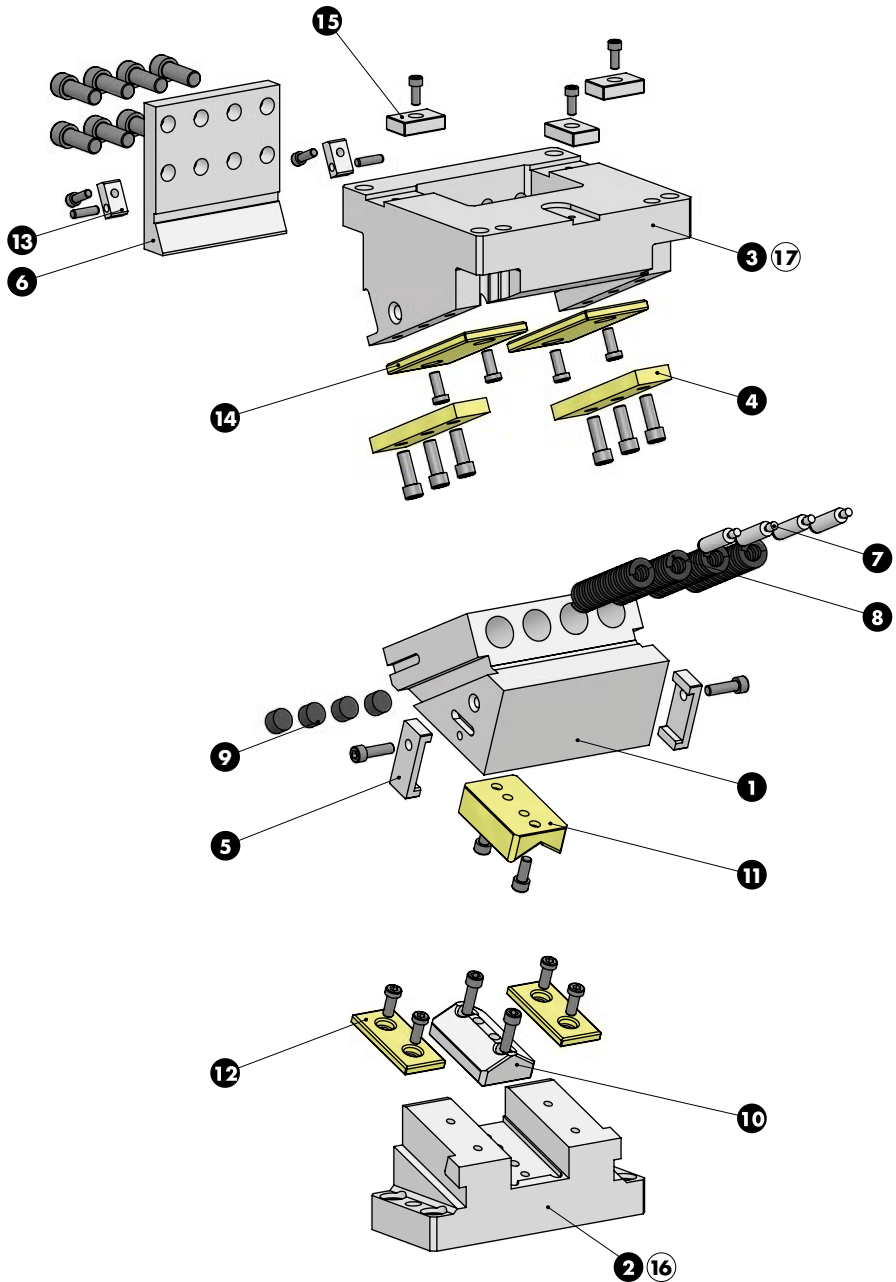

AERIAL CAM UNIT - OBEN HÄNGENDER SCHIEBER - UNITÀ A CAMME SOSPESA

SLIDER STRUCTURE, POSITIVE RETURN STRUCTURE AND CLEARANCES

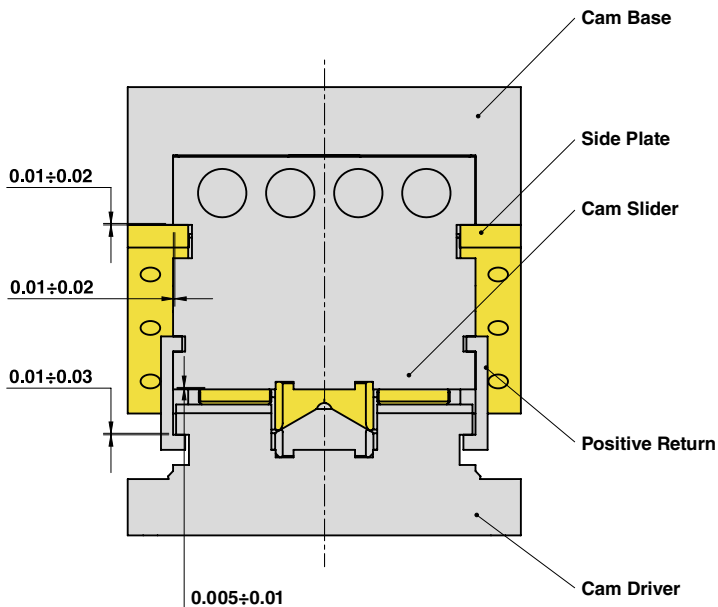

Cam Units CHK

PART LIST

Particular number	Description	Material	Quantity
1	Cam Slider	GG-25 + Graphite	1
2	Cam Driver	GG-25 + Graphite	1
3	Cam Base	GG-25	1
4	Side Plate	CuZn25Al5 + Graphite - HB > 190	2
5	Positive Return	CK45	2
6	Stopper Plate	St44	1
7	Spring Guide Pin	34CrMo4	4
8	Spring	-	4
9	Elastomer Cap	Elastomer 92SH	4
10	Male "V" Driver	CK45	1
11	Female "V" Driver	CuZn25Al5+ Graphite - HB > 190	1
12	Wear Plate	CuZn25Al5+ Graphite - HB > 190	2
13	Plate	CK45	2
14	Wear Plate	CuZn25Al5 - HB > 190	2
15	Key	CK45	3
16	Cam Driver Fixing Screws M16x60 DIN 912	-	4
17	Cam Base Fixing Screws M16x70 DIN 912	-	4