



Cam Units CLK
Schieber CLK
Unità a Camme CLK

OMCR[®]
STANDARD DIE COMPONENTS

2018.01

OMCR CODE	Work Angle	Slider Width (mm)	Closed Cam Height (mm)	Work Area W x H (mm)	Max Work Force with shoulder 10 ⁶ cycles (kN)	Extraction Force (kN)	Page number
	β				F _s	F _e	
CLK065	0÷70°	65	210	65 x "F"	39÷58	0,32÷0,85	836
CLK100	0÷70°	100	280	100 x "F"	87÷96	1÷2,29	840
CLK200	0÷70°	200	280	200 x "F"	193÷231	1,98÷4,59	844



Dynamic technical staff and advanced design methods

AERIAL CAM UNIT - OBEN HÄNGENDER SCHIEBER - UNITÀ A CAMME SOSPESA

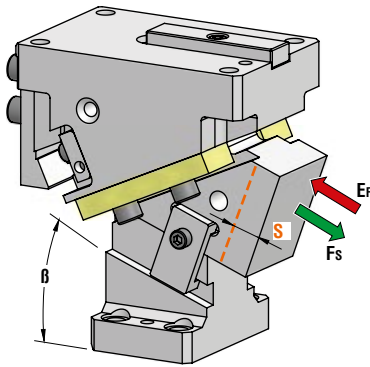

P.605

OMCR CODE	Work Angle β	Max Stroke (mm) S	Max Work Force with shoulder (kN) F_s	Extraction Force (kN)
				E_f Spring
CLK065.00	0°	26,87	39	0,79
CLK065.05	5°	26,97	39	0,77
CLK065.10	10°	31,61	39	0,85
CLK065.15	15°	32,23	39	0,77
CLK065.20	20°	33,76	39	0,85
CLK065.25	25°	35	39	0,77
CLK065.30	30°	33,46	46	0,85
CLK065.35	35°	35,38	46	0,77
CLK065.40	40°	42,91	46	0,85
CLK065.45	45°	46,49	46	0,77
CLK065.50	50°	54,45	58	0,77
CLK065.55	55°	43,59	58	0,62
CLK065.60	60°	50	58	0,54
CLK065.65	65°	47,32	58	0,39
CLK065.70	70°	58,48	58	0,32



Art.	Work Angle = 5°
CLK065	05

OMCR CODE	Work Angle β	Overall Dimensions (mm)					
		A	B	C	D	E	F
CLK065.00	0°	185,94	56,57	75	155	55	80
CLK065.05	5°	193,01	56,57	70	150	55	90
CLK065.10	10°	196,80	67,58	70	150	40	80
CLK065.15	15°	203,77	68,81	67	147	40	90
CLK065.20	20°	198,10	74,31	60	140	10	80
CLK065.25	25°	204,75	76,73	55	135	10	90
CLK065.30	30°	193,63	89,52	50	130	10	80
CLK065.35	35°	199,76	93,06	45	125	10	90
CLK065.40	40°	188,72	99,62	40	120	15	80
CLK065.45	45°	194,13	104,16	34	114	15	90
CLK065.50	50°	190	110	30	110	10	90
CLK065.55	55°	190	115	20	100	10	100
CLK065.60	60°	190	115	20	100	10	100
CLK065.65	65°	190	130	0	80	10	110
CLK065.70	70°	190	130	0	80	10	110

AERIAL CAM UNIT - OBEN HÄNGENDER SCHIEBER - UNITÀ A CAMME SOSPESA

X VIEW

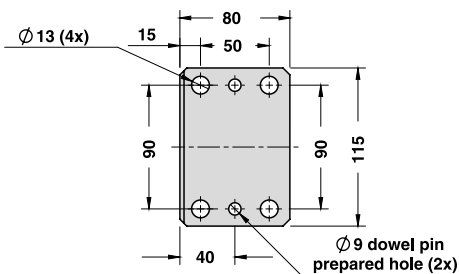
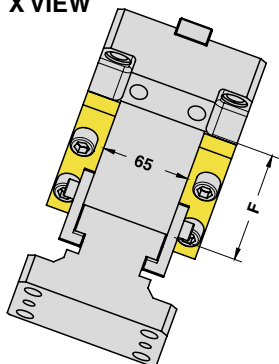

CAM DIAGRAM

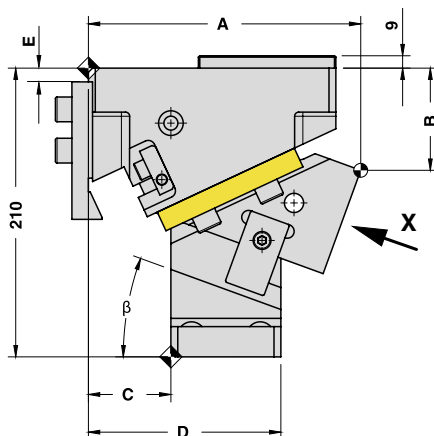
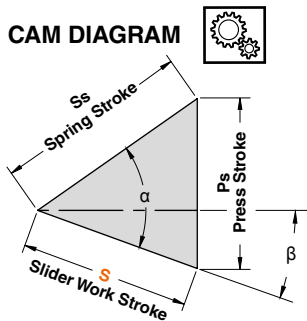

Work Angle	Inner Angle	Slider Work Stroke (mm)	Press Stroke (mm)	Spring Stroke (mm)
β	α	S	Ps	Ss
0°	45°	26,87	26,87	38
5°	50°	26,97	29,22	38
10°	45°	31,61	27,28	38
15°	50°	32,23	30,14	38
20°	45°	33,76	26,34	35
25°	50°	35,00	29,58	35
30°	45°	33,46	24,49	30
35°	50°	35,38	28,06	30
40°	45°	42,91	30,46	33
45°	50°	46,49	35,75	33
50°	50°	54,45	41,71	35
55°	55°	43,59	35,70	25
60°	60°	50,00	43,30	25
65°	65°	47,32	42,89	20
70°	70°	58,48	54,95	20

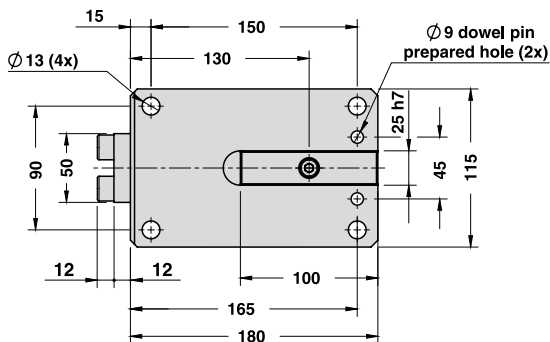

AERIAL CAM UNIT - OBEN HÄNGENDER SCHIEBER - UNITÀ A CAMME SOSPESA

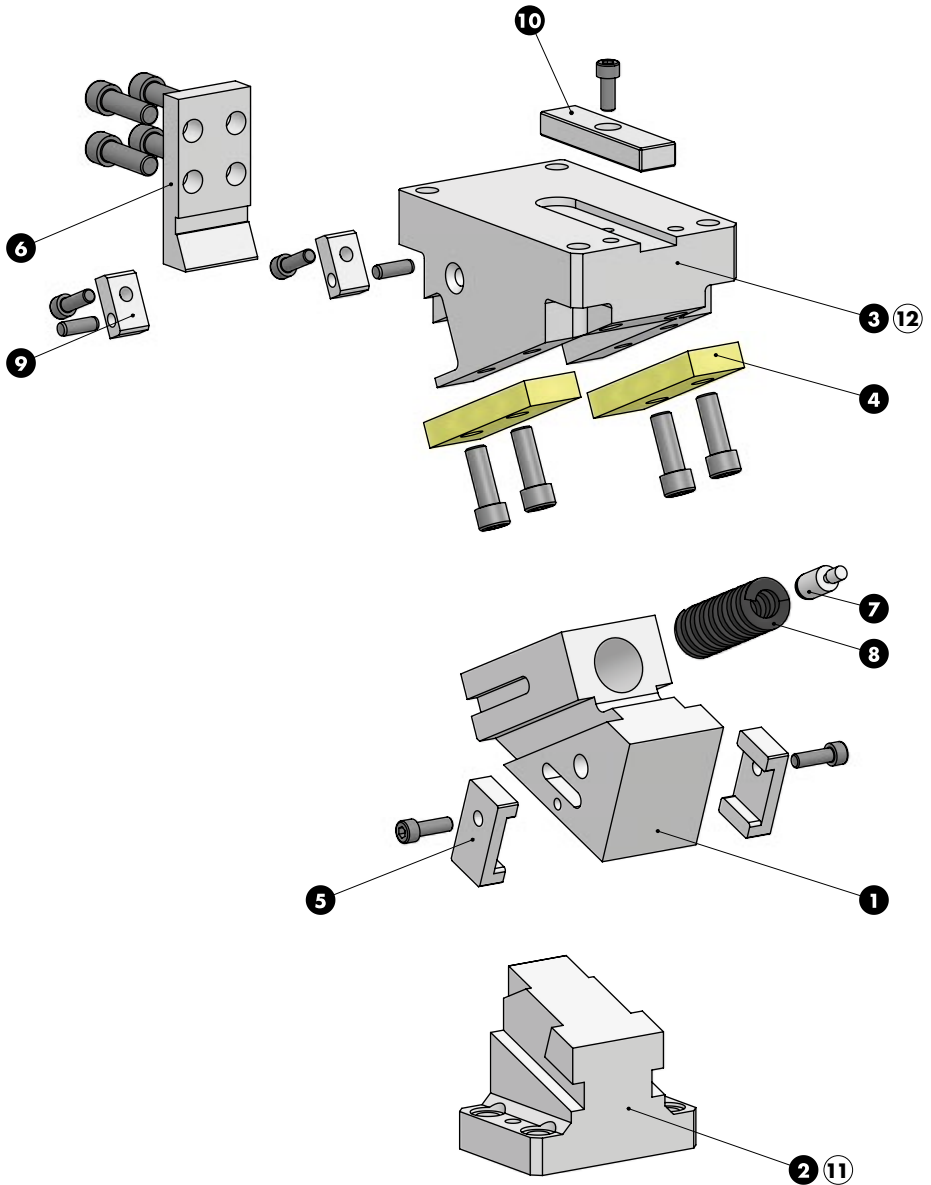

AERIAL CAM UNIT - OBEN HÄNGENDER SCHIEBER - UNITÀ A CAMME SOSPESA

SLIDER STRUCTURE, POSITIVE RETURN STRUCTURE AND CLEARANCES

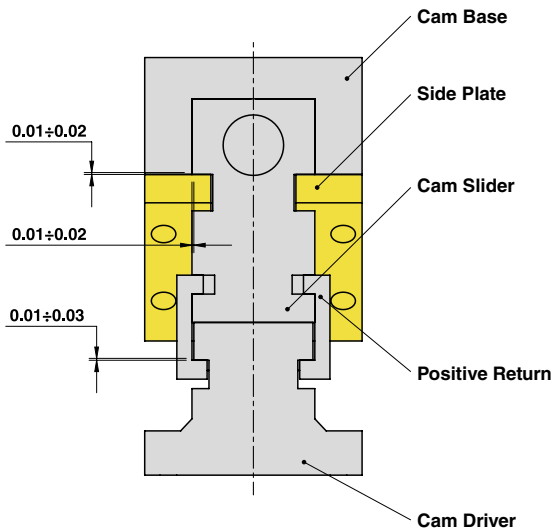

Cam Units CLK

PART LIST

Particular number	Description	Material	Quantity
1	Cam Slider	GG-25 + Graphite	1
2	Cam Driver	GG-25 + Graphite	1
3	Cam Base	GG-25	1
4	Side Plate	CuZn25Al5 + Graphite - HB > 190	2
5	Positive Return	CK45	2
6	Stopper Plate	St44	1
7	Spring Guide Pin	34CrMo4	1
8	Spring	-	1
9	Plate	CK45	2
10	Key	CK45	1
11	Cam Driver Fixing Screws M12x45 DIN 912	-	4
12	Cam Base Fixing Screws M12x55 DIN 912	-	4

AERIAL CAM UNIT - OBEN HÄNGENDER SCHIEBER - UNITÀ A CAMME SOSPESA

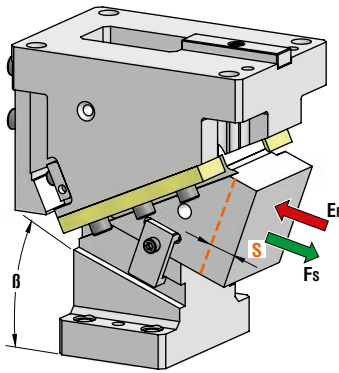

P.605

OMCR CODE	Work Angle β	Max Stroke (mm) S	Max Work Force with shoulder (kN) F_s	Extraction Force (kN)
				E_f Spring
CLK100.00	0°	28,28	87	2,10
CLK100.05	5°	28,39	87	2,09
CLK100.10	10°	33,27	87	2,29
CLK100.15	15°	33,92	87	2,09
CLK100.20	20°	30,86	87	2,23
CLK100.25	25°	32	87	2,03
CLK100.30	30°	33,46	87	2,10
CLK100.35	35°	35,38	87	1,91
CLK100.40	40°	39,01	87	2,10
CLK100.45	45°	42,26	87	1,91
CLK100.50	50°	46,67	96	1,91
CLK100.55	55°	52,30	96	1,70
CLK100.60	60°	60	96	1,48
CLK100.65	65°	47,32	96	1,22
CLK100.70	70°	58,48	96	1



Art.	Work Angle = 5°
CLK100	05

OMCR CODE	Work Angle β	Overall Dimensions (mm)						
		A	B	C	D	E	F	G
CLK100.00	0°	240	85	60	170	55	100	17
CLK100.05	5°	236,89	73,82	60	170	55	140	17
CLK100.10	10°	240	90	60	170	35	100	17
CLK100.15	15°	254,35	81,51	60	170	35	140	17
CLK100.20	20°	240	110	50	160	15	100	18
CLK100.25	25°	253,26	102,6	50	160	15	140	18
CLK100.30	30°	240	110	30	140	10	120	17
CLK100.35	35°	252,34	109,69	30	140	10	140	17
CLK100.40	40°	240	115	30	140	10	120	17
CLK100.45	45°	247,41	114,68	30	140	10	140	17
CLK100.50	50°	240	120	10	120	10	140	16
CLK100.55	55°	240	145	0	110	10	140	16
CLK100.60	60°	240	145	0	110	10	140	16
CLK100.65	65°	240	145	0	110	10	140	16
CLK100.70	70°	240	145	0	110	10	140	16

AERIAL CAM UNIT - OBEN HÄNGENDER SCHIEBER - UNITÀ A CAMME SOSPESA

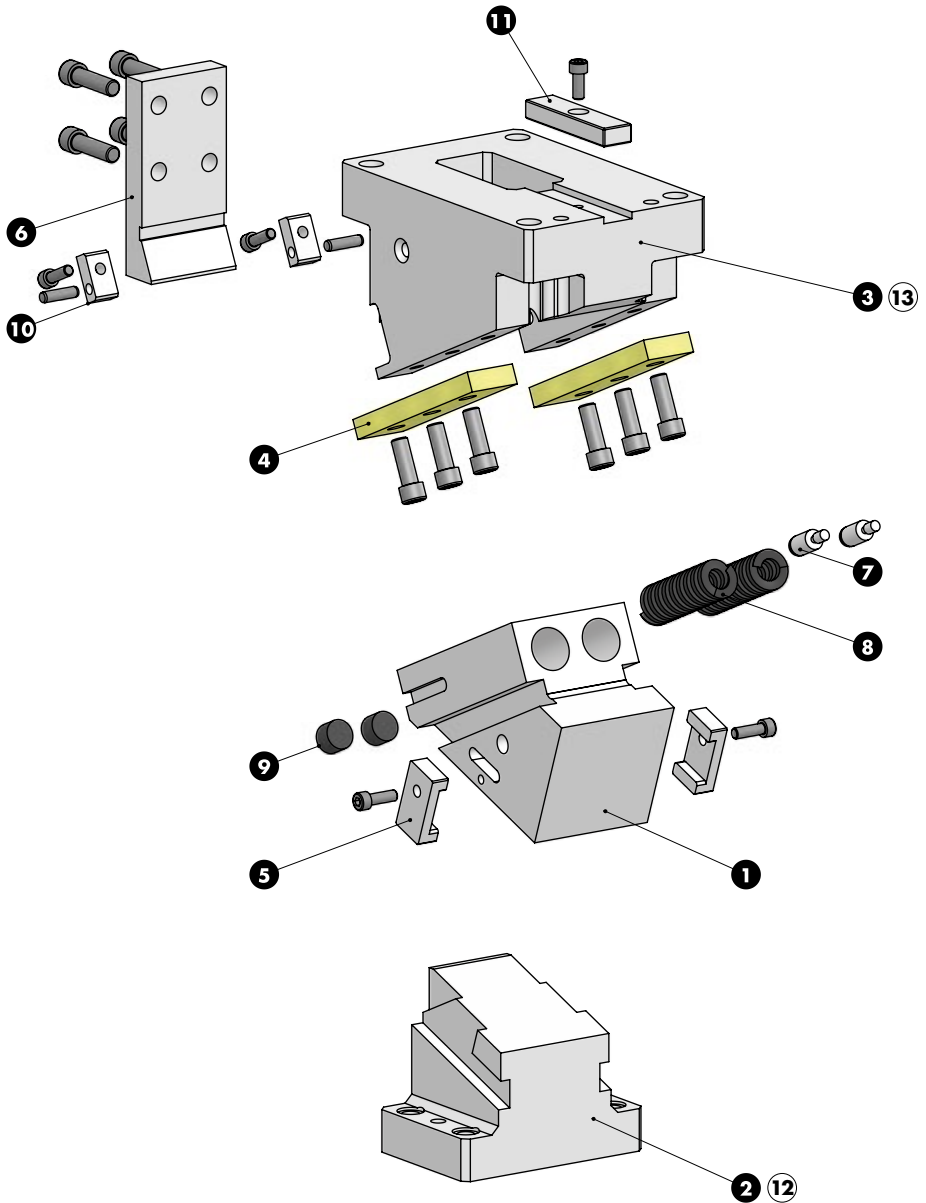

AERIAL CAM UNIT - OBEN HÄNGENDER SCHIEBER - UNITÀ A CAMME SOSPESA

SLIDER STRUCTURE, POSITIVE RETURN STRUCTURE AND CLEARANCES

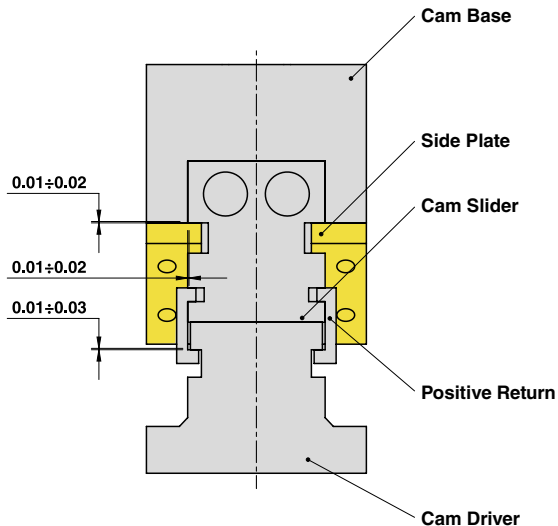

Cam Units CLK

PART LIST

Particular number	Description	Material	Quantity
1	Cam Slider	GG-25 + Graphite	1
2	Cam Driver	GG-25 + Graphite	1
3	Cam Base	GG-25	1
4	Side Plate	CuZn25Al5 + Graphite - HB > 190	2
5	Positive Return	CK45	2
6	Stopper Plate	St44	1
7	Spring Guide Pin	34CrMo4	2
8	Spring	-	2
9	Elastomer Cap	Elastomer 92SH	2
10	Plate	CK45	2
11	Key	CK45	1
12	Cam Driver Fixing Screws M12x55 DIN 912	-	4
13	Cam Base Fixing Screws M16x70 DIN 912	-	4

AERIAL CAM UNIT - OBEN HÄNGENDER SCHIEBER - UNITÀ A CAMME SOSPESA

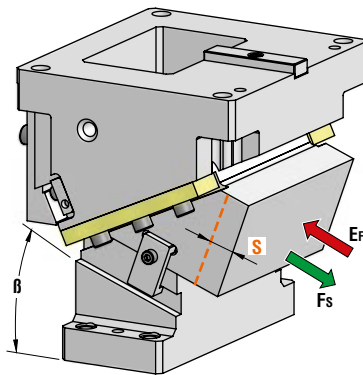

P.605

OMCR CODE	Work Angle β	Max Stroke (mm) S	Max Work Force with shoulder (kN) F_s	Extraction Force (kN)
				E_f Spring
CLK200.00	0°	28,28	193	4,21
CLK200.05	5°	28,39	193	4,17
CLK200.10	10°	33,27	193	4,59
CLK200.15	15°	33,92	193	4,17
CLK200.20	20°	30,86	193	4,46
CLK200.25	25°	32	193	4,05
CLK200.30	30°	33,46	193	4,20
CLK200.35	35°	35,38	193	3,81
CLK200.40	40°	39,01	193	4,20
CLK200.45	45°	42,26	193	3,81
CLK200.50	50°	46,67	231	3,81
CLK200.55	55°	52,30	231	3,40
CLK200.60	60°	60	231	2,97
CLK200.65	65°	47,32	231	2,45
CLK200.70	70°	58,48	231	1,98



Art.	Work Angle = 5°
CLK200	05

OMCR CODE	Work Angle β	Overall Dimensions (mm)							
		A	B	C	D	E	F	G	H
CLK200.00	0°	240	90	60	170	60	100	17	190
CLK200.05	5°	236,82	78,84	60	170	60	130	17	190
CLK200.10	10°	240	90	60	170	35	100	17	150
CLK200.15	15°	254,35	81,51	60	170	35	130	17	150
CLK200.20	20°	240	110	50	160	15	100	18	150
CLK200.25	25°	253,27	102,6	50	160	15	130	18	150
CLK200.30	30°	240	110	30	140	10	120	17	150
CLK200.35	35°	252,34	109,69	30	140	10	140	17	150
CLK200.40	40°	240	115	30	140	10	120	17	150
CLK200.45	45°	247,41	114,68	30	140	10	140	17	150
CLK200.50	50°	240	120	10	120	10	140	16	150
CLK200.55	55°	240	145	0	110	10	140	16	150
CLK200.60	60°	240	145	0	110	10	140	16	150
CLK200.65	65°	240	145	0	110	10	140	16	150
CLK200.70	70°	240	145	0	110	10	140	16	150

AERIAL CAM UNIT - OBEN HÄNGENDER SCHIEBER - UNITÀ A CAMME SOSPESA

X VIEW

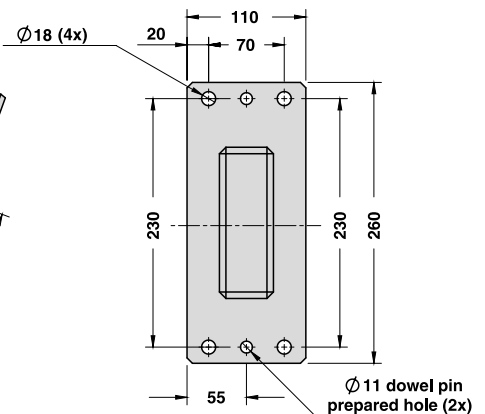
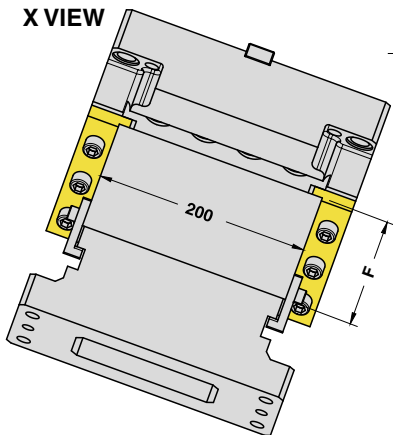

CAM DIAGRAM

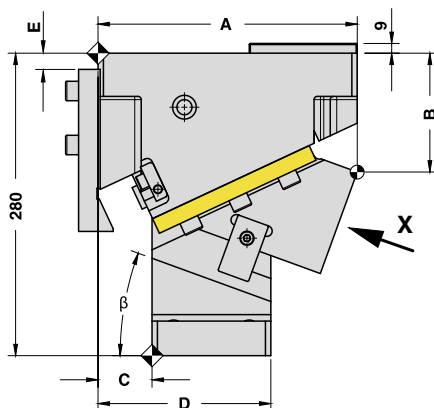
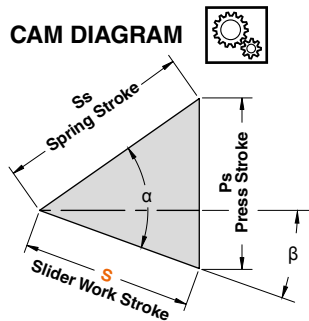

Work Angle	Inner Angle	Slider Work Stroke (mm)	Press Stroke (mm)	Spring Stroke (mm)
β	α	S	Ps	Ss
0°	45°	28,28	28,28	40
5°	50°	28,39	30,76	40
10°	45°	33,27	28,72	40
15°	50°	33,92	31,72	40
20°	45°	30,86	24,08	32
25°	50°	32,00	27,05	32
30°	45°	33,46	24,49	30
35°	50°	35,38	28,06	30
40°	45°	39,01	27,69	30
45°	50°	42,26	32,50	30
50°	50°	46,67	35,75	30
55°	55°	52,30	42,84	30
60°	60°	60,00	51,96	30
65°	65°	47,32	42,89	20
70°	70°	58,48	54,95	20

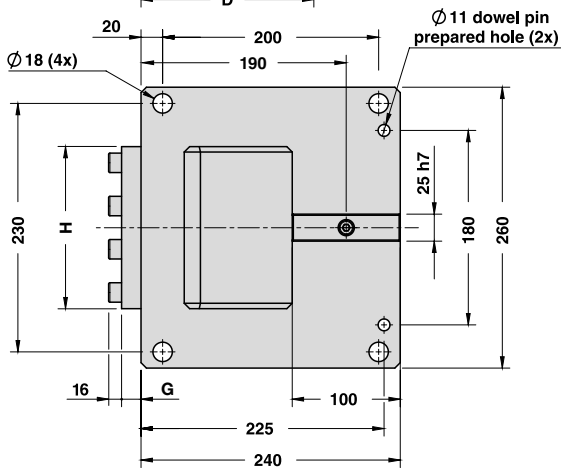

AERIAL CAM UNIT - OBEN HÄNGENDER SCHIEBER - UNITÀ A CAMME SOSPESA

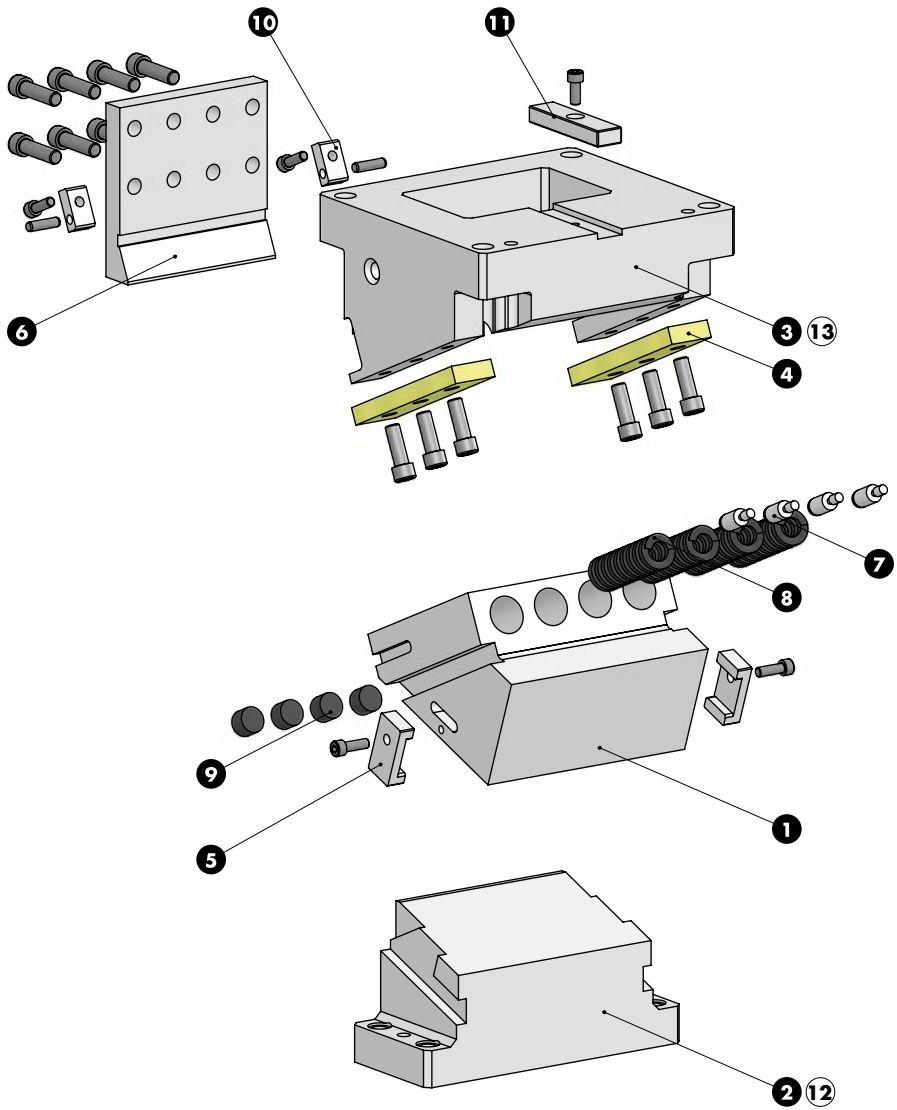

AERIAL CAM UNIT - OBEN HÄNGENDER SCHIEBER - UNITÀ A CAMME SOSPESA

SLIDER STRUCTURE, POSITIVE RETURN STRUCTURE AND CLEARANCES

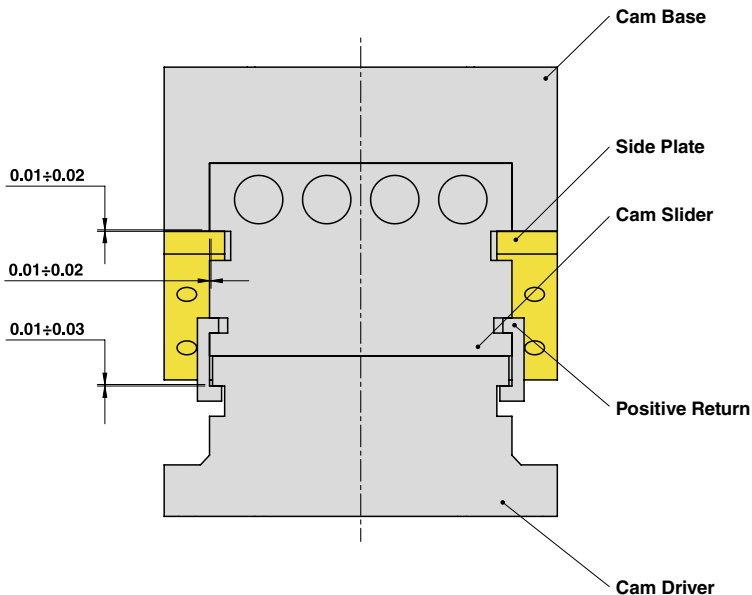

Cam Units CLK

PART LIST

Particular number	Description	Material	Quantity
1	Cam Slider	GG-25 + Graphite	1
2	Cam Driver	GG-25 + Graphite	1
3	Cam Base	GG-25	1
4	Side Plate	CuZn25Al5 + Graphite - HB > 190	2
5	Positive Return	CK45	2
6	Stopper Plate	St44	1
7	Spring Guide Pin	34CrMo4	4
8	Spring	-	4
9	Elastomer Cap	Elastomer 92SH	4
10	Plate	CK45	2
11	Key	CK45	1
12	Cam Driver Fixing Screws M16x60 DIN 912	-	4
13	Cam Base Fixing Screws M16x70 DIN 912	-	4