



Flexible **slewing rings** and **rotary joints**

Our slewing rings are connecting elements used for transferring rotary motion. A classic application example is the rotating bearing on the front axle at the hitch for a truck trailer.

The single-row ball-rotary joints can accommodate axial and radial forces as well as the resulting tilting forces. The rotary joint is optionally available with external or internal teeth if you require a degree of automation.

Versions

- 🌀 lightweight slewing rings
- 🌀 design turntables
- 🌀 ball steering rings
- 🌀 ball-rotary joints
- 🌀 ball-rotary joints with external or internal teeth

Areas of use

- 🌀 machine construction
- 🌀 agriculture
- 🌀 furniture industry
- 🌀 loading facilities
- 🌀 automotive industry
- 🌀 and much more

lightweight slewing rings // up to 300 kg

Lightweight slewing rings

Lightweight slewing rings made of metal and plastic are the ideal solution for aligning pallets. They consist of two concentric rings made of metal or plastic. The rotation of the two rings occurs through numerous steel balls, which guarantee the highest gliding ability.

The rotating mechanisms allow the rotation of the outer ring when it is lying on one side; if it lies on the other side, the inner ring rotates. The rings are each equipped with rubber suction cups to prevent slipping. Each ring is fitted with rubber suction cups to prevent slippage. They can be attached on both sides and also on inclined surfaces.

The racks on the inner rings of some units enable a degree of automation.



Slewing rings series LE	Da mm	Di mm	La mm	Li mm	H mm	B mm	material	axial load kg
LE230-10 Ident No.: 0018809	230	165	213	180	18	4.50	plastic, black	200
LE230-30 Ident No.: 0018810	230	165	213	180	18	4.50	plastic, transparent	200
LE280-10 Ident No.: 0018811	280	202	263	230	18	4.50	plastic, black	200
LE280-30 Ident No.: 0018812	280	202	263	230	18	4.50	plastic, transparent	200
LE320-10 Ident No.: 0018813	328	260	315	278	16	4.50	metal, black	300
LE320-20 Ident No.: 0018814	328	260	315	278	16	4.50	metal, grey	300



-30 transparent



-10 black

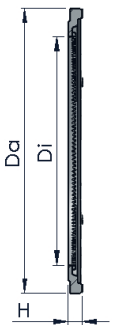
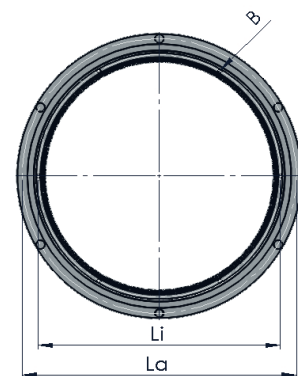

Lightweight plastic slewing rings

for rotating stands and rotating tables in the furniture industry

LES-160

load-carrying capacity: 100 kg
Ø 160 mm
Ident No. 0018822



LES-300

load-carrying capacity: 150 kg
Ø 300 mm
Ident No. 0018823



Various attachment options

- a 10-mm hole is made in the center of the plate (underside). Insert the nylon bushing (diameter: 11 x 6 MA) into the hole in the plate. Center, insert screw, and tighten
- center the slewing ring on the plate. Tighten the screws in the holes of the washers resting on the plate (underside)
- make a slightly countersunk hole for the M8 screw in the center of the base plate. Place both plates on top of each other. Insert the M8 screw and tighten



ball steering rings // up to 3,500 kg

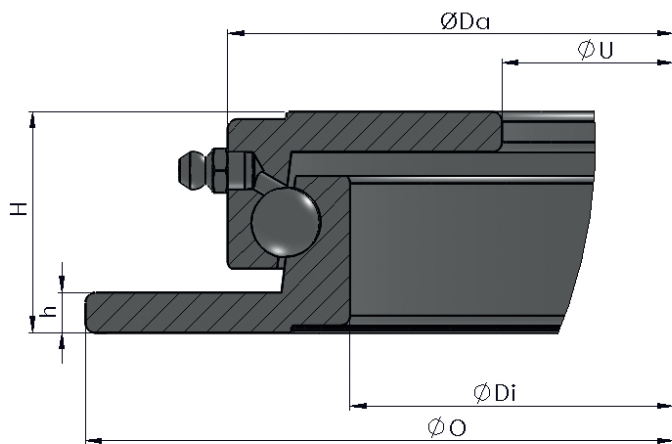

Ball steering rings: series L and N

- ball steering rings for lightweight to heavy axial loads of 750 – 4,500 kg
- precision ball steering rings consist of 2 steel rings with rolling bearing steel balls in the ball race with lubrication nipple at the periphery
- low construction height with high axial load; wear-resistant
- both flange rings in profiles L and N are without a drill hole
- suitable for trailers and transportation equipment



ball steering ring series L	Da mm	Di mm	O mm	U mm	H mm	h mm	swivel range °	axial load kg
400L Ident No.: 0012065	342	292	400	230	45	8	120	750
500L Ident No.: 0012661	442	392	500	330	45	8	120	900
650L Ident No.: 0013778	592	542	650	480	45	8	120	1,500
750L Ident No.: 0014186	692	642	750	580	45	8	120	1,800
850L Ident No.: 0014577	792	742	850	680	45	8	120	2,500
950L Ident No.: 0014718	892	842	950	780	45	8	120	3,000
1050L Ident No.: 0010103	992	942	1,050	880	45	8	120	3,500

- the axial loads specified are applicable for three axle truck trailers. These axial loads can be exceeded by 10% for two-axle trucks trailers. The values can be exceeded by 20% at speeds below 25 km/h.



“Swiveling range 120°”

ball steering rings series N	Da mm	Di mm	O mm	U mm	H mm	h mm	swivel range °	axial load kg
500N Ident No.: 0012663	437	384	500	330	52	8	120	1,800
650N Ident No.: 0013780	587	534	650	465	52	8	120	2,500
750N Ident No.: 0014188	687	634	750	565	52	8	120	3,000
850N Ident No.: 0014579	787	734	850	665	52	8	120	3,500
950N Ident No.: 0014720	887	834	950	765	52	8	120	4,000
1050N Ident No.: 0010105	987	934	1,050	865	52	8	120	4,500

ball steering rings // up to 1,750 kg



Ball steering rings: series L-360°

- ball steering rings for lightweight to heavy axial loads of 380 – 1,750 kg
- precision ball steering rings consist of 2 steel rings with rolling bearing steel balls in the ball race with lubrication nipple at the periphery
- additionally hardened spacer balls in the ball race
- low construction height with high axial load; wear-resistant



ball steering rings series L-360	Da mm	Di mm	O mm	U mm	H mm	h mm	swivel range °	axial load kg
400L-360 Ident No.: 0012066	346	294	404	236	42	8	360	380
500L-360 Ident No.: 0012662	446	394	504	336	42	8	360	450
650L-360 Ident No.: 0013779	596	544	654	486	42	8	360	750
750L-360 Ident No.: 0014187	696	644	754	586	42	8	360	900
850L-360 Ident No.: 0014578	796	744	854	686	42	8	360	1,250
950L-360 Ident No.: 0014719	896	844	954	786	42	8	360	1,500
1050L-360 Ident No.: 0010104	996	944	1,054	886	42	8	360	1,750

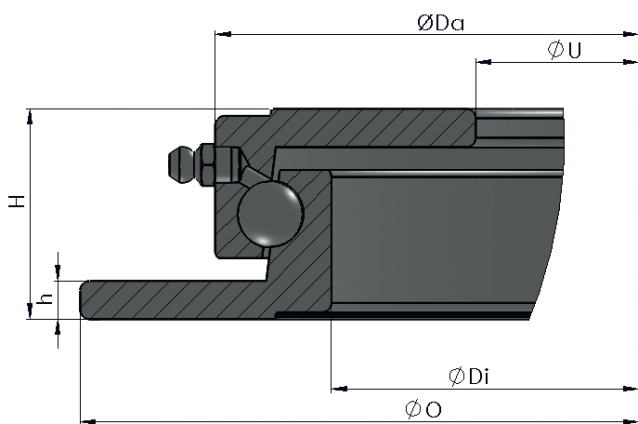

Ball steering rings: series HE

- ball steering rings for high axial loads of 3,000 – 13,000 kg
- precision ball steering rings consist of two steel rings with rolling bearing steel balls in the ball race with lubrication nipple at the periphery
- low construction height with high axial load; wear-resistant
- the HE6 and HE1200/22 steering rings have drilled holes



“Swiveling range 120°”

ball steering rings series HE	Da mm	Di mm	La mm	Li mm	O mm	U mm	H mm	h mm	B mm	swivel range °	axial load kg
HE4 Ident No.: 0016756	700	588	671	657	685	567	80	9	-	120	3,000
HE6 Ident No.: 0016758	1,105	993	1,074	1,060	1,090	972	80	9	18	120	6,500
HE12-1,000 Ident No.: 0016749	1,008	886	974	960	1,000	859	90	10	-	120	7,000
HE1,000-22 Ident No.: 0016746	1,008	886	974	960	1,000	859	90	10	-	120	10,000
HE1200-22 Ident No.: 0016750	1,208	1,086	1,174	1,160	1,200	1,059	90	10	18	120	13,000

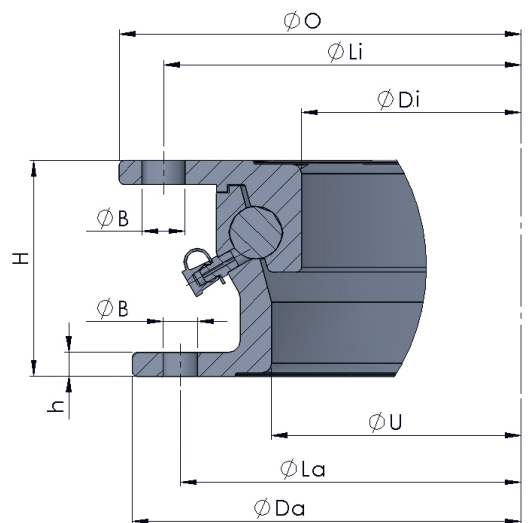



Rotary joints, series L-360 AZ and IZ

This type series is a lightweight version from our slewing bearings portfolio. Rolling elements made of ball bearing steel, with surface hardened ball tracks. Material : C 45 N, according to DIN 17200 permissible bending stress at the base of the tooth: 130 N/mm^2 normal, 260 N/mm^2 (brief maximum). The bearing cross sections of this type series are kept relatively small to improve their cost efficiency. Therefore, the slewing bearings should be mounted to a torsionally rigid companion structure. The bearing surfaces for the slewing bearings must be even so that the bearings are not twisted when screwed in. This could result in bottlenecks in the track, which would then cause load peaks at these locations. Thus, the bearing surfaces must be mechanically machined.



rotary joints L-360 AZ	DL mm	Da mm	Di mm	La mm	Li mm	O mm	U mm	C mm	H mm	d mm	No. of teeth	b mm	module	UF norm. kN	UF max. kN
500L-360-AZ Ident No.: 0028349	414	505	304	455	332	412.50	415.50	368	56	495	99	44.50	5	11.83	23.66
650L-360-AZ Ident No.: 0028350	544	640	434	585	462	542.50	545.50	498	56	630	105	44.50	6	14.20	28.40
750L-360-AZ Ident No.: 0028351	644	742	534	685	562	642.50	645.50	598	56	732	122	44.50	6	14.20	28.40
850L-360-AZ Ident No.: 0028355	744	840	634	785	662	742.50	745.50	698	56	828	138	44.50	6	14.20	28.40
950L-360-AZ Ident No.: 0028354	844	950	734	885	762	842.50	845.50	798	56	936	117	44.50	8	18.93	37.86
1050L-360-AZ Ident No.: 0028356	944	1046	834	985	862	942.50	945.50	898	56	1,032	129	44.50	8	18.93	37.86
1200L-360-AZ Ident No.: 0028357	1,094	1,198	984	1,135	1,012	1,092.50	1,095.50	1,048	56	1,184	148	44.50	8	18.93	37.86

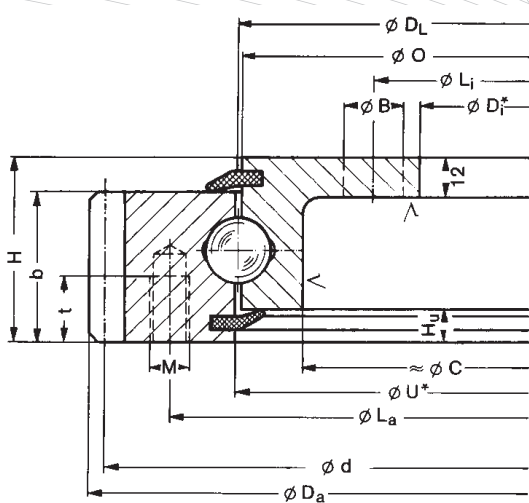

Legende

- thread depth t: 20 mm
- distance down to the outside ring Hu: 11.50 mm
- bore- \varnothing M: 12 mm
- bore- \varnothing B: 18 mm



“Rotary joint with internal teeth”

rotary joints L -360 iZ	DL mm	Da mm	Di mm	La mm	Li mm	O mm	U mm	C mm	H mm	d mm	No. of teeth	b mm	modul	UF norm. kN	UF max. kN
500L-360-IZ Ident No.: 0028358	414	518	325	490	375	412.50	415.50	454	56	335	67	44.50	5	12.32	24.64
650L-360-IZ Ident No.: 0028359	544	648	445	620	505	542.50	545.50	584	56	456	76	44.50	6	14.79	29.58
750L-360-IZ Ident No.: 0028360	644	748	546	720	605	642.50	645.50	684	56	558	93	44.50	6	14.79	29.58
850L-360-IZ Ident No.: 0028361	744	848	649	820	705	742.50	745.50	784	56	660	110	44.50	6	14.79	29.58
950L-360-IZ Ident No.: 0028362	844	948	736	920	805	842.50	845.50	884	56	752	94	44.50	8	19.79	39.44
1050L-360-IZ Ident No.: 0028363	944	1,048	840	1,020	905	942.50	945.50	984	56	856	107	44.50	8	19.79	39.44
1200L-360-IZ Ident No.: 0028364	1,094	1,198	986	1,170	1,055	1,092.50	1,095.50	1,134	56	1,000	125	44.50	8	19.79	39.44

Legende

- thread depth t: 20 mm
- distance down to the outside ring Hu: 11.50 mm
- bore-Ø M: 12 mm
- bore-Ø B: 18 mm

