



TORWEGGE Materials Handling Technology:

- Energy supplies for power and compressed air
- Spring cable reels
- Box type conductor rails
- C-rail program with wall- or column-mounted swivel arm up to 125 kg
- Suspension track program
- Wall- and column-mounted jib crane 150 kg and over with electric chain hoists
- Vacuum lifters
- Crane systems

Catalog pages: H ① – H 70

Materials handling technology: One of four strong product divisions!

Spring cable reel

Spring cable reels provide automatic cable winding for mobile consumers. The operational area covers practically all devices in lifting and conveyor technology, including gantry cranes, gripper arms and magnets, elevating and work platforms, machine carriages, mobile platforms, and truck cranes up to longitudinal circular scrapers in wastewater treatment plants, Further applications: in machine and system engineering, in harbor areas, in steelworks, and in theater and stage technology.

Protected operation

With standardized slip ring element in an impact-resistant plastic housing (up to 47 A at 100% duty cycle and 1000 V).

Trouble-free operation with a high service life thanks to the high-quality, roller bearing mounting on both sides.

Optimum corrosion protection even in aggressive environments

Side plates made of galvanized steel sheet powdered-coated drum casing.

The cable for the highest operational demands

Trommelflex PUR-HF

Specially developed for drum operation, high tensile loading capacity, abrasion-resistant, halogen-free.



For high load cycles, springs manufactured from high-quality spring steel.

Minimum drum dimensions

Through the use of the optimum cable with the smallest outside diameter.

Change of rotational direction – simple and safe, the springs are securely integrated in protective cassettes.

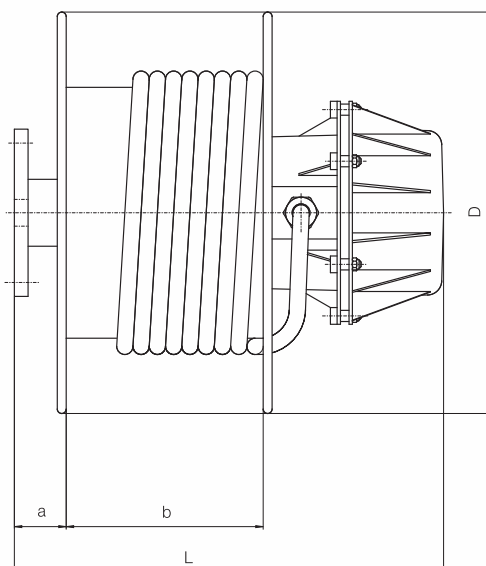

Ident. No.	Order No.	Dimensions			
		D mm	L mm	b mm	a mm
0030435	SGR01	280	295	95	48
0030436	SGR02	280	295	95	48
0030437	SGR03	480	405	95	48
0030438	SGR04	480	405	95	48
0030439	SGR11	430	365	200	47
0030440	SGR12	430	466	200	47
0030441	SGR14	430	466	200	47
0030442	SGR15	430	466	200	47
0030443	SGR17	430	466	200	47
0030444	SGR18	430	506	200	47
0030445	SGR19	430	506	200	47
0030446	SGR20	430	506	200	47
0030447	SGR21	430	596	200	47
0030448	SGR22	430	596	200	47
0030449	SGR23	430	596	200	47
0030450	SGR32	460	486	220	47
0030451	SGR36	460	526	220	47
0030452	SGR37	460	526	220	47
0030453	SGR38	460	616	220	47
0030454	SGR40	460	616	220	47
0030455	SGR53	550	541	235	47
0030456	SGR70	385	466	160	47
0030457	SGR71	385	466	160	47
0030458	SGR72	385	556	160	47
0030459	SGR73	385	556	160	47
0030460	SGR82	550	631	235	47
0030461	SGR90	650	665	252	64
0030462	SGR91	650	665	252	64
0030463	SGR92	650	665	252	64

Spring cable reel

Wide range of application possibilities indoors and outdoors

Cable [mm ²]	Voltage V _{max} [V]	Current I _{max1} [A] *	Current I _{max2} [A] **	Horizontal application			Vertical application		
				Winding length [m]	Ident. No.	Order No.	Winding length [m]	Ident. No.	Order No.
4 x 2.5	415	25	12	8	0030435	SGR01	8	0030435	SGR01
			10	18	0030436	SGR02	17	0030436	SGR02
			12	28	0030439	SGR11	28	0030439	SGR11
7 x 1.5	415	16	5	8	0030437	SGR03	8	0030437	SGR03
			7	18	0030440	SGR12	18	0030440	SGR12
			5	28	0030441	SGR14	28	0030441	SGR14
7 x 2.5	415	25	8	8	0030438	SGR04	8	0030438	SGR04
			10	18	0030442	SGR15	18	0030442	SGR15
			8	28	0030443	SGR17	27	0030450	SGR32
12 x 1.5	415	16	5	8	0030456	SGR70	8	0030456	SGR70
			5	18	0030444	SGR18	18	0030444	SGR18
			4	28	0030445	SGR19	26	0030445	SGR53
12 x 2.5	415	25	8	8	0030457	SGR71	8	0030457	SGR71
			7	18	0030448	SGR22	17	0030451	SGR36
			7	28	0030452	SGR37	27	0030461	SGR90
18 x 1.5	415	16	5	8	0030458	SGR72	8	0030458	SGR72
			4	18	0030447	SGR21	17	0030453	SGR38
			3	28	0030448	SGR22	27	0030462	SGR91
18 x 2.5	415	25	7	8	0030459	SGR73	8	0030459	SGR73
			6	18	0030449	SGR23	18	0030460	SGR82
			6	28	0030454	SGR40	27	0030459	SGR73

* Maximum current [A] with completely wound cable and three conductors loaded (acc. to VDE 0298, part 4)

** Maximum current [A] with completely wound cable and all conductors loaded (acc. to VDE 0298, part 4)

Flange dimensions:

Flange 1 at SRG 01 to SGR 05

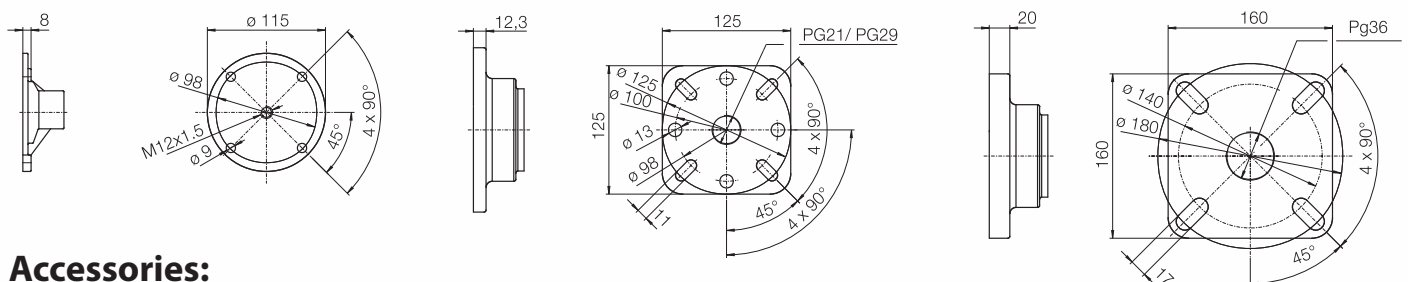

Accessories:

Cable stocking:

For strain-relieved suspension of cables - safe and easy to use.

The retaining force of the cable stocking is transferred to a long section of cable via the flexible wire mesh.

Size A:

Order number: 1036969

For cables 7 x 2.5 and smaller

Size B:

Order number: 1036970

For cables 12 x 1.5 and larger

Product similar to illustrations!

www.torwegge-group.com

Box type conductor rail

The proven and universally applicable system for power supply is used in crane installations, transfer carriages, workstation supply units, and a wide range of other mobile consumers both indoors and outdoors, preferably with a straight track.

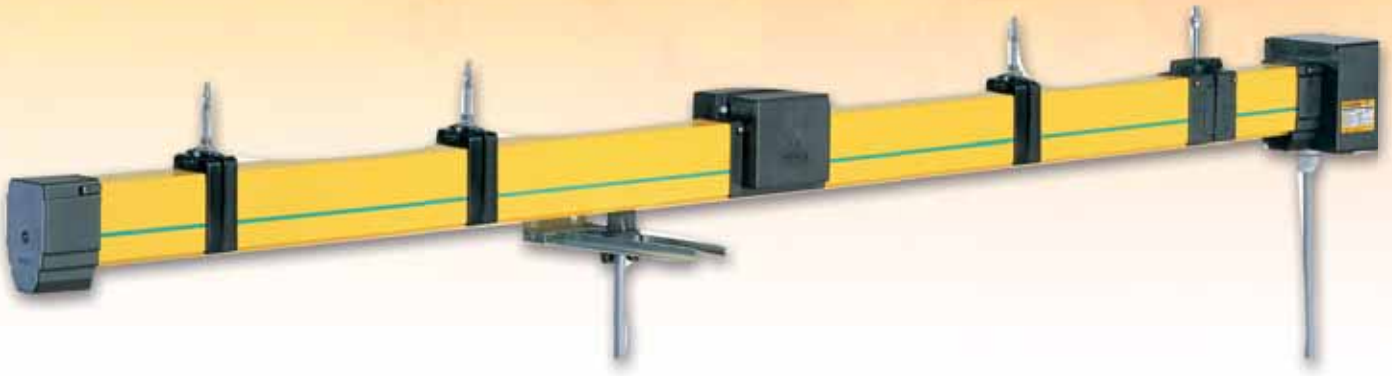

Technical data

Design:	4-, 5-, and 7-pin
Nominal current/nominal voltage:	35 A and 60 A/35 V to 600 V
Conductor material:	Copper
Housing material:	PVC
System length:	Up to 100 meters, larger system lengths on request.
Support spacing:	Max. 2000 mm
Driving speed:	Up to 150m/min
Allowable ambient temperature:	-30°C to +55°C
Protection class:	IP 23



Single carrier gantry crane



Supply for crane installation

Box type conductor rail

1. Conductor line rails

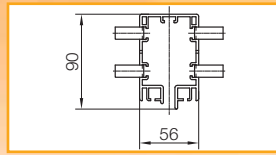

2. Track connector

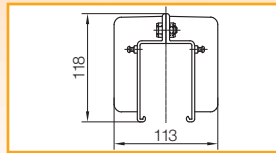

3. Fixed point bracket

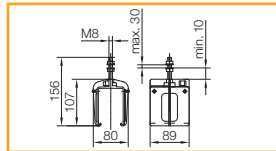

4. Track holding clamp

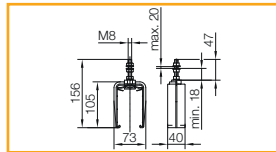

5. End cap

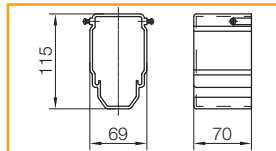

6. End power feed

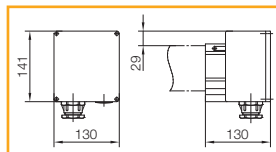

7. Current collector

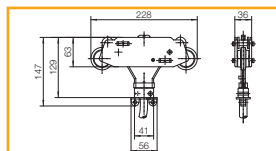

8. Fork attachment

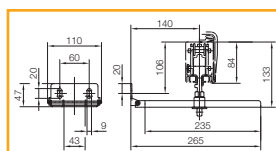

Number of poles	Nominal current (A) at 100% duty cycle	Length (m)	Ident. No.	Order No.
4	35	4	0030396	N084213-34x4x12
5			0030397	N084213-34x5x13
7			0030398	N084213-34x7x15
4	60	4	0030399	N084213-54x4x12
5			0030400	N084213-54x5x13
7			0030401	N084213-54x7x15

Number of poles	Ident. No.	Order No.
4	0030402	N084224-4
5	0030403	N084224-5
7	0030404	N084224-7

Ident. No.	Order No.
0030405	N084231-11

1 unit per system

Ident. No.	Order No.
0030406	N084241-11

Max. support spacing 2 meters

Ident. No.	Order No.
0030407	N084271

Number of poles	Nominal current (A)	Cable cross section (mm ²)	Connection	Ident. No.	Order No.
5	35	10	Pg 21	0030408	N084251-051
5	60	16	Pg 29	0030409	N084251-052
7	35	10	Pg 21	0030410	N084251-071
7	60	16	Pg 29+11	0030411	N084251-076

Number of poles	Nominal current 60% duty cycle (A)	Cable cross section (mm ²)	Ident. No.	Order No.
4	25	2.5	0030412	N084201-4x1
4	40	4	0030413	N084201-4x2
5	25	2.5	0030414	N084201-5x1
5	40	4	0030415	N084201-5x2
7	25	2.5	0030416	N084203-7x1
7	40	4	0030417	N084203-7x2

*Other lengths available on request

Ident. No.	Order No.
0030418	N084291-2

For attachment to (customer-supplied) mobile consumer

Product portrait

Zero gravity balancers and spring balancers

For the widest range of applications in industry and handwork



Spring balancers are designed so that with increasing cable extension, the retraction force increases, causing the work load to be pulled back to the initial position by the spring pull. This frees up the workplace for other tools or equipment and keeps it unobstructed.

Balancers are equipped with tapered cable drums. This prevents an increasing retraction force over the entire cable extension. The position of the work load remains unchanged. This enables stress-free working over a longer time period.

The **automatic locking** results in an early retraction stop at a predetermined position, with slow return of the work load. The lock does not engage with fast retraction. Is used if the attached work load should not be completely returned.

Note:

The weight of the tool or equipment to be attached, including the supply line and any necessary accessories, is the main criterion for selection of a spring balancer or balancer.

Spring balancers

According to DIN15112 – practical and safe –



Our spring balancers are indispensable aids for use wherever control switches suspended with strain relief and portable power and air tools, such as drills, drivers, taps and dies, welding and riveting tools, and similar devices must be readily available at a specific height. The equipment suspended by the cable can be moved with minimal effort.

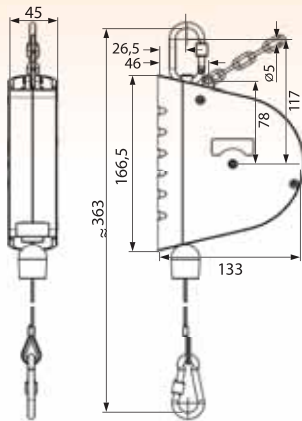

Type 7200

- Housing and cable drum made of plastic.
- Rigid attachment eye.
- Carabiner snap hook
- Infinitely variable load setting through clamping spring tension.
- Tension spring held in press-on tire.
- Adjustable stop within the cable extension device.

Ident. No.	Order No.	Load-carrying capacity (kg)	Cable extension (mm)
0014019	7200/1	0.3 – 1.5	1600
0019441	7200/2	1.2 – 2.5	1600

Type 7211

- Plastic housing and cable drum, cover made of steel sheet.
- Rotatable attachment eye.
- Carabiner snap hook
- Infinitely variable load setting through clamping spring tension.
- Riveted tension spring.

0014029	7211/1-2	0.5 – 2.0	2500
0034148	7211/2-2	1.5 – 3.0	2500

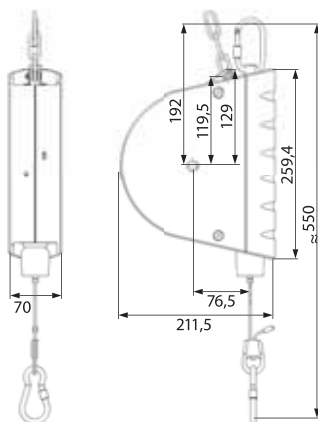

Type 7221

- Plastic housing, cable drum and cover made of steel sheet.
- Rotatable safety hook.
- Carabiner snap hook
- Infinitely variable load setting through clamping spring tension.
- Tension spring held in press-on tire.
- Safeguard in case of spring breakage.
- Cable length adjustment.

0014038	7221/1-3	2.0 – 5.0	3000
0014040	7221/2-3	4.0 – 8.0	3000
0014042	7221/3-3	7.0 – 10.0	3000
0014044	7221/4-3	10.0 – 14.0	3000

Type 7222

- With automatic locking mechanism.
- Otherwise like type 7221.

Automatic lock			
0014047	7222/1	2.0 – 5.0	3000
0014049	7222/2	4.0 – 8.0	3000
0014051	7222/3	7.0 – 10.0	3000
0014053	7222/4	10.0 – 14.0	3000

Balancer

According to DIN15112 – practical and safe –

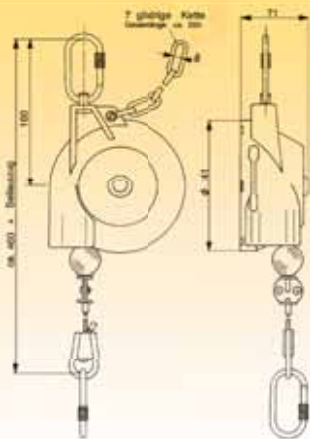

Type 7228 Zero gravity balancers

- Housing and cable drum made of impact-resistant plastic.
- Rotatable safety hook.
- Painted steel sheet housing cover.
- Riveted tension spring.
- Cable length adjustment.
- Cable extension limitation.

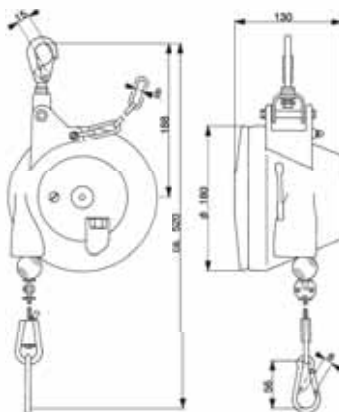

Type 7230 Zero gravity balancers

- Housing and cable drum made of plastic.
- Rotatable safety hook.
- Carabiner snap hook
- Riveted tension spring.
- Infinitely variable load setting through worm gear.
- Safeguard in case of spring breakage.
- Locking mechanism.
- Mechanical fall arrester (shackle).
- Cable extension limitation.
- Adjustable stop with rubber buffer.
- Cable length adjustment.

Type 7231 Zero gravity balancers

- With automatic locking mechanism for locking the wire rope.
- Otherwise like type 7230.

Ident. No.	Order No.	Load-carrying capacity (kg)	Cable extension (mm)
0034801	7228/1	0.4 – 1.2	1600
0034804	7228/2	1.2 – 2.6	1600
0034805	7228/3	2.6 – 3.8	1600
0034806	7228/4	3.8 – 5.2	1600
0034807	7228/5	5.2 – 6.5	1600

Ident. No.	Order No.	Load-carrying capacity (kg)	Cable extension (mm)
0014064	7230/1	3.0 – 5.0	2000
0014065	7230/2	4.5 – 7.0	2000
0014066	7230/3	6.0 – 10.0	2000
0014067	7230/4	9.0 – 14.0	2000
0014068	7230/5	13.0 – 17.0	2000

Automatic lock

0014069	7231/1	3.0 – 5.0	2000
0014070	7231/2	4.5 – 7.0	2000
0014072	7231/3	6.0 – 10.0	2000
0014073	7231/4	9.0 – 14.0	2000
0014074	7231/5	13.0 – 17.0	2000

Nylon cable balancer



Small balancer series Load-carrying capacity 0.5 – 11 kg

- Housing made of coated steel sheet.

Ident. No.	Order No.	Load-carrying capacity (kg)	Cable extension (mm)
0014153	7301/1	0.5 – 1.5	2300
0014154	7301/2	1.0 – 2.0	2300
0014155	7301/3	2.0 – 3.5	2300
0014156	7302/1	3.0 – 6.0	2300
0014157	7302/2	5.0 – 8.5	2300
0014158	7302/3	8.0 – 11.0	2300

Aluminum spring balancer

- Simple and stable aluminum construction.
- Stainless steel wire cable.
- Adjustable loading range.
- Additional safety suspension.
- Adjustable extension limitation.
- Low-friction cable guide.

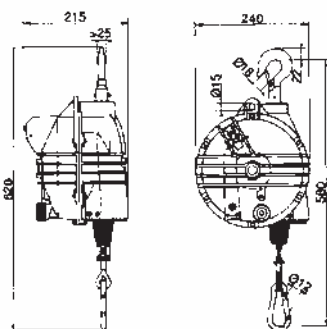
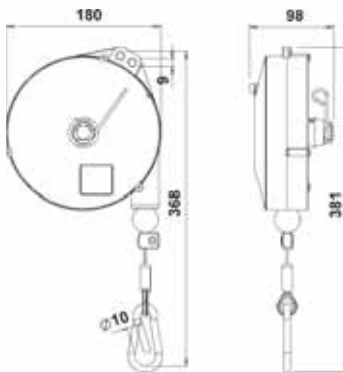
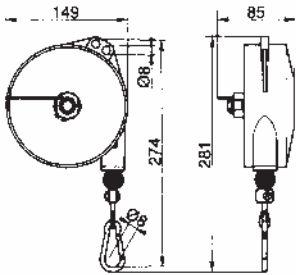
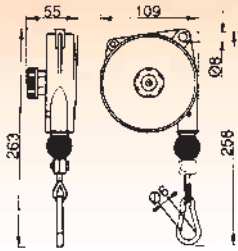
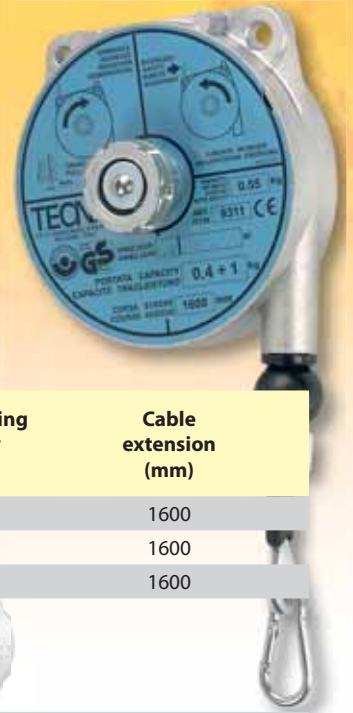

Ident. No.	Order No.	Load-carrying capacity (kg)	Cable extension (mm)
0014027	7211/1-1.6	0.4 – 1.0	1600
0014030	7211/2-1.6	1.0 – 2.0	1600
0014031	7211/3-1.6	2.0 – 3.0	1600
0014034	7213/1-2.0	1.0 – 2.5	2000
0014035	7213/2-2.0	2.0 – 4.0	2000
0014036	7213/3-2.0	4.0 – 6.0	2000
0014037	7213/4-2.0	6.0 – 8.0	2000
0014039	7221/1-2.5	2.0 – 4.0	2500
0014041	7221/2-2.5	4.0 – 6.0	2500
0014043	7221/3-2.5	6.0 – 8.0	2500
0014045	7221/4-2.5	8.0 – 10.0	2500
0014046	7221/5-2.5	10.0 – 14.0	2500

Spring balancer with blocking mechanism.

0014048	7222/1-2.5	2.0 – 4.0	2500
0014050	7222/2-2.5	4.0 – 6.0	2500
0014052	7222/3-2.5	6.0 – 8.0	2500
0014054	7222/4-2.5	8.0 – 10.0	2500

Spring balancer (blocking mechanism for securing and releasing the load at the desired height).

0014094	7250/1-2.0	10.0 – 15.0	2000
0014100	7250/2-2.0	15.0 – 20.0	2000
0014102	7250/3-2.0	20.0 – 25.0	2000
0014104	7250/4-2.0	25.0 – 30.0	2000
0014106	7250/5-2.0	30.0 – 35.0	2000
0014108	7250/6-2.0	35.0 – 45.0	2000
0014110	7250/7-2.0	45.0 – 55.0	2000
0014113	7250/8-2.0	55.0 – 65.0	2000
0014115	7250/9-2.0	65.0 – 75.0	2000

Product portrait

C-rail program



Energy is supplied for tools for all work procedures.

Energy supply systems (power and compressed air) and conductor lines (power) for low clearances create freedom of movement in assembly and handling technology. Areas of application include the steel and metal industry, automotive construction, wood and furniture industry, electrical and textile industry, packaging and cleaning sectors, and training workshops.

TORWEGGE offers you everything from one source:
Planning – consulting – a complete program!

Supplementary programs:

Line and hose retractors
Balancers, spring balancers.

*Guaranteed accident
safety and tidiness!*

Order form C-rail program
Recommended installation for programs NO 23200 and NO 24100

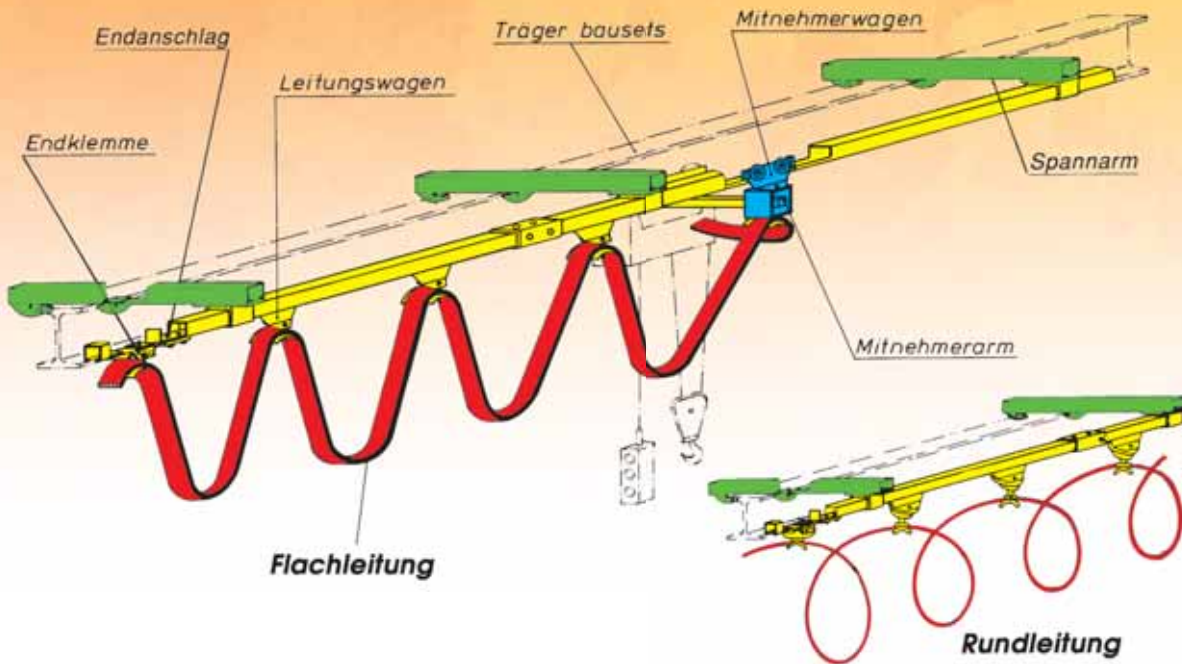

Fax... and go!
 ● Copy
 ● Fill in
 ● Fax to 0521-93417661
 Request for quote
 order

Make your own parts list for your energy supply system:

	30	40				
Customer-supplied support	32 x 30 x 2	40 x 40 x 2.5	Ident. No.	Order No.	Piece/Meter	Page
Clamping arm			NO 20185 - ____	NO 20186 - ____	____ Piece	____
Clamping jaw			NO 20180-8	NO 20180-8	____ Piece	____

Customer-supplied ceiling construction

C-rail 4000 mm	NO 23200-4	NO 24100-4	____ Meter	____
C-rail 6000 mm	NO 23200-6	NO 24100-6	____ Meter	____
Track holding clamp	NO 23____	NO 24____	____ Piece	____
Track connector	NO 23____	NO 24____	____ Piece	____
End stop	NO 23____	NO 24____	____ Piece	____
Cap	NO 20662-30	NO 20662-40	____ Piece	____

Flat cable

Round cable

End clamp	NO 23____	NO 24____	____ Piece	____
Collector trolleys	NO 23____	NO 24____	____ Piece	____
Cable trolleys	NO 23____	NO 24____	____ Piece	____
Cable holder (round cable)	NO ____-____	NO ____-____	____ Piece	____

C-rails and fastening material

For program 23200 for C-rail 32 x 30 x 2

For program 24100 for C-rail 40 x 40 x 2.5

C-rail

Materials:

Stock length:

Available:

Steel, Sendzimir-galvanized, V4A.

4000 mm / 6000 mm
(Other lengths available on request.)

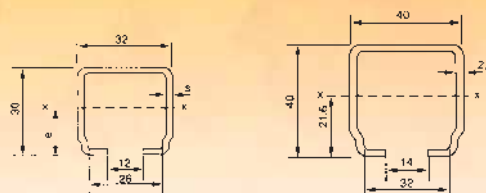

Available:
Steel, sendzimir-galvanized, V4A.

Dimensions	a,b,s (mm)	32 x 30 x 2	40 x 40 x 2.5		
Static values	Ix (cm ⁴)	2.42	6.74		
	Wx (cm ³)	1.45	3.08		
Weight	(kg/m)	1.560	2.500		
Length tolerance	(mm)	+ 40	+ 40		
		Ident. No.	Order No.	Ident. No.	Order No.
S. galv.	4000 mm	0020473	NO 23200-4	0020611	NO 24100-4
S. galv.	6000 mm	0020475	NO 23200-6	0020613	NO 24100-6
V4A	4000 mm	0028932	NO 23400-4	0028933	NO 24109-4
V4A	6000 mm	0020573	NO 23400-6	0028934	NO 24109-6

Your price advantage: For C-rail pack.



Cap

Materials:

Plastic

Application:

For sealing the ends of the rails.

30

40

Ident. No.	Order No.	Ident. No.	Order No.
0020437	NO 20662-30	0020438	NO 20662-40



Track connector

Materials:

Steel, galvanized

Application:

A track connector must be provided at each joint.

30

40

Ident. No.	Order No.	Ident. No.	Order No.
0020487	NO 23210	0020627	NO 24105
Weight in kg	0.280	Weight in kg	0.610

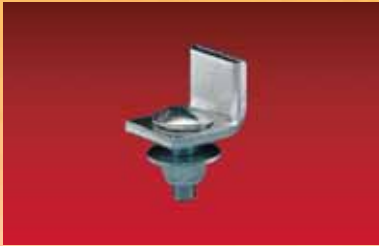

End stop

Materials: Steel, galvanized; buffer, rubber.
Application: For protecting the cable trolleys at the end of the rail.

30

40



	Ident. No.	Order No.	Ident. No.	Order No.
Sing., w/out buffer	0020488	NO 23215	Not available	
Double, without buffer	0020490	NO 23219	0020629	NO 24110
Double, with buffer	0020489	NO 23218	0020630	NO 24111

90° elbow

Materials: Steel, galvanized.
Application: For a horizontal change in direction of the track.

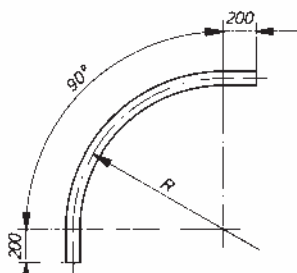

Design with straight ends with R = 250 to 800 mm.

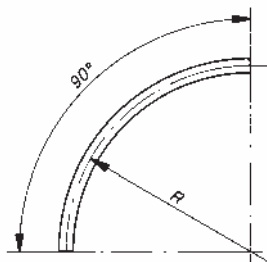

Design without straight ends R = 1000 mm and larger.



Radius	Extended length	For max. trolley length	For max. cable sag	30		40	
mm	mm	mm	mm	Ident. No.	Order No.	Ident. No.	Order No.
250	793	-	-	0020483	NO 23203-250	-	-
400	1028	80	-	0020484	NO 23203-400	-	-
400	1028	-	-	-	-	0020622	NO 24102-400
600	1342	100	-	0020485	NO 23203-600	-	-
600	1342	-	-	-	-	0020623	NO 24102-600
800	1656	125	-	0020486	NO 23203-800	-	-
800	1656	100	-	-	-	0020624	NO 24102-800
1000	1570	160	350	0020477	NO 23203-1000	-	-
1000	1570	100	350	-	-	0020615	NO 24102-1000
1200	1885	160	420	0020478	NO 23203-1200	-	-
1200	1885	125	420	-	-	0020616	NO 24102-1200
1400	2200	200	490	0020479	NO 23203-1400	-	-
1400	2200	160	490	-	-	0020617	NO 24102-1400
1600	2510	200	560	0020480	NO 23203-1600	-	-
1600	2510	160	560	-	-	0020618	NO 24102-1600
2000	3140	280	700	0020482	NO 23203-2000	-	-
2000	3140	200	700	-	-	0020620	NO 24102-2000

The bends according to this standard are available on short notice. The price of the next size up is charged for in-between sizes. Bends with larger radii are available on request.

Fastening material



Track holding clamp

Materials: Steel, galvanized.
 Application: For fastening the rails.

30

40

Allow. load	P (kg)	63	100
Bracket width	b (mm)	84	112
Hole spacing	a (mm)	60	80
		Ident. No.	Order No.
Without mounting		0020491	NO 23220
With square nut		0020493	NO 23222
With nut and bolt		0020494	NO 23223

Track holding clamp + connector for welded connection

Materials: Steel, bare.
 Small parts galvanized.
 Application: For welded connection or special attachments for installation by customer.

30

40

Bracket length	l (mm)	50	50
Connector length	l (mm)	100	125
		Ident. No.	Order No.
Bracket		0020495	NO 23224
Connector		0020503	NO 23232

Track holding clamp and connector

Materials: Steel, galvanized.
 Application: For fastening and connecting the rails.

30

40

Allow. load	P (kg)	160	250
Bracket length	l (mm)	50	50
Connector length	l (mm)	100	125
Bracket width	b (mm)	80	110
Connector width	b (mm)	80	110
Hole spacing	a (mm)	60	80
		Ident. No.	Order No.
Bracket	without mounting	0020496	NO 23225
	with square nut	0020497	NO 23226
	with nut and bolt	0020498	NO 23227
Connector	without mounting	0020499	NO 23228
	with square nut	0020500	NO 23229
	with nut and bolt	0020501	NO 23230

Fastening material



Track holding clamp

Materials: Steel, galvanized.
Application: For fastening the rails.

30

40

Allow. load	P (kg)	100	250
Bracket length	l (mm)	50	50
		Ident. No.	Order No.
Bracket		0020506	NO 23241
		Ident. No.	Order No.
		0020640	NO 24131



Track holding clamp

Materials: Steel, galvanized.
Application: For fastening the rails.

30

40

Allow. load	P (kg)	100	250
Bracket length	l (mm)	50	50
		Ident. No.	Order No.
Bracket		0020507	NO 23242
		Ident. No.	Order No.
		0020641	NO 24132



Track holding clamp

Materials: Steel, galvanized.
Application: For fastening the rails.

30

40

Allow. load	P (kg)	100	250
Bracket length	l (mm)	50	50
		Ident. No.	Order No.
Bracket		0020505	NO 23240
		Ident. No.	Order No.
		0020639	NO 24130



Track holding clamp and connector

Materials: Steel, galvanized.
Application: For fastening and connecting the rails.

30

40

Allow. load	P (kg)	63	100
Bracket length	l (mm)	50	50
Connector length	l (mm)	100	125
Length of thread M8	(mm)	48	45
		Ident. No.	Order No.
Bracket		0020502	NO 23231
		Ident. No.	Order No.
Connector		0020504	NO 23233
		Ident. No.	Order No.
		0020647	NO 24144



Fastening material

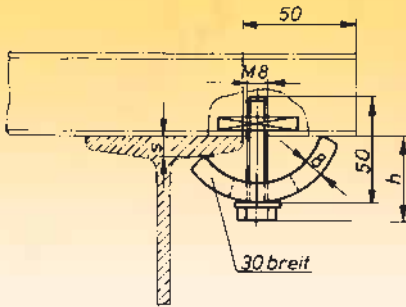

Clamping jaw

Materials: Steel, galvanized.
Application: For fastening the clamping arm to the T-beam

Clamping thickness »s«	(mm)	4	6	8	10	12	16	20
Installation height »h«	(mm)	31	32	33	34	35	37	40

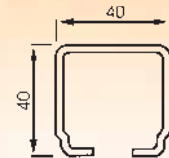
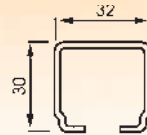

Ident. No.	0020365	0020365
Order No.	NO 20180-8	NO 20180-8

Also available:

Ident. No.	Order No.
0020363	NO 20180-10
0020364	NO 20180-12

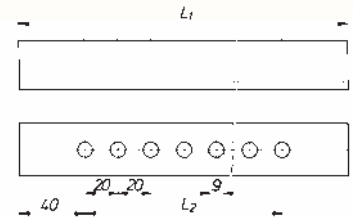

Clamping arm

Materials: Steel, galvanized.
Application: For clamping the rail.



30

40

L1	L2	30		40	
mm	mm	Ident. No.	Order No.	Ident. No.	Order No.
250	200	0020369	NO 20185-250	0020381	NO 20186-250
315	260	0020370	NO 20185-315	0020382	NO 20186-315
400	340	0020371	NO 20185-400	0020383	NO 20186-400
500	340	0020372	NO 20185-500	0020384	NO 20186-500
630	340	0020373	NO 20185-630	0020385	NO 20186-630
800	340	0020374	NO 20185-800	0020386	NO 20186-800
1000	340	0020367	NO 20185-1000	0020379	NO 20186-1000
1250	340	0020368	NO 20185-1250	0020380	NO 20186-1250

Carrier arm

Materials: Steel, galvanized.
Application: For transporting the collector trolley.

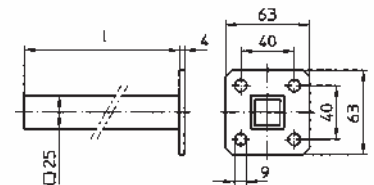

30

40

Length L	30		40	
mm	Ident. No.	Order No.	Ident. No.	Order No.
400	0020388	NO 20195-400	0020388	NO 20195-400
630	0020389	NO 20195-630	0020389	NO 20195-630



Bolt + bolt assembly

30

40

Ident. No.	0020362	0020362
Order No.	NO 20176-8x16	NO 20176-8x16



Leaving technical changes!

Fastening material

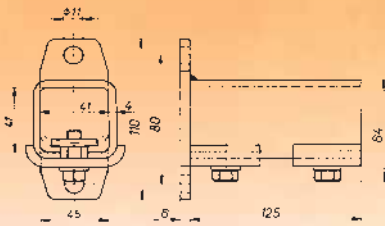

Track holding clamp

Materials: Steel, galvanized.

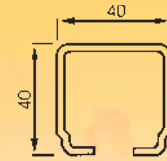
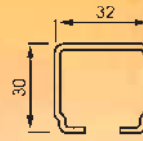

	Ident. No.	Order No.	Ident. No.	Order No.
Bracket	0020410	NO 20280	0020412	NO 20282
Clamping arm		NO 20185		NO 20186

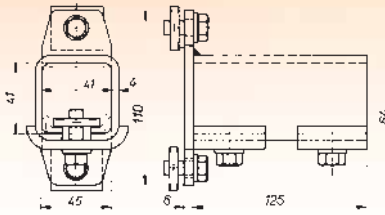

Materials: Steel, galvanized.



	Ident. No.	Order No.	Ident. No.	Order No.
Bracket	0020411	NO 20281	0020413	NO 20283
Clamping arm		NO 20185		NO 20186

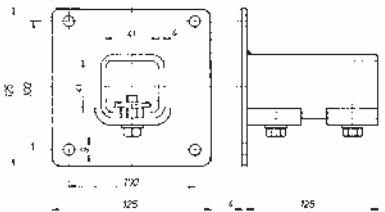

Materials: Steel, galvanized.



	Ident. No.	Order No.	Ident. No.	Order No.
Bracket	0020414	NO 20284	0020414	NO 20284
Clamping arm	-	-		NO 20186

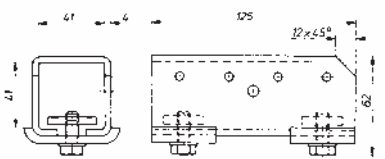

Materials: Bracket – steel, bare.
Counter plate – steel, galvanized. For welded connection.



	Ident. No.	Order No.	Ident. No.	Order No.
Bracket	0020415	NO 20285	0020428	NO 20286
Clamping arm		NO 20185		NO 20186

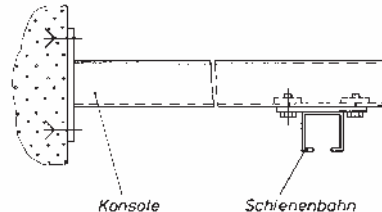
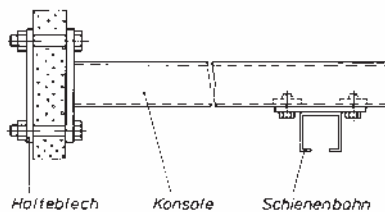

Possible mounting types

Bracket

Materials: Steel, galvanized.

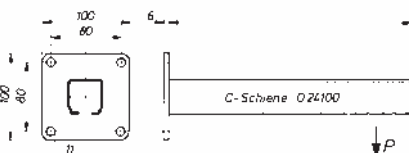

Weight P max	Length L	30		40	
		Ident. No.	Order No.	Ident. No.	Order No.
80	500	0020391	NO 20206-500	0020391	NO 20206-500
63	630	0020392	NO 20206-630	0020392	NO 20206-630
50	800	0020393	NO 20206-800	0020393	NO 20206-800
40	1000	0020390	NO 20206-1000	0020390	NO20206-1000

Holding plate

Materials: Steel, galvanized.

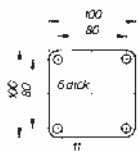

Ident. No.	Order No.	Ident. No.	Order No.
0020429	NO 20295	0020429	NO 20295

Cable trolleys for flat cables



A

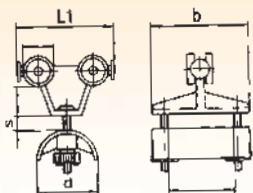

B + C

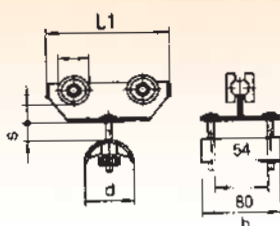

D

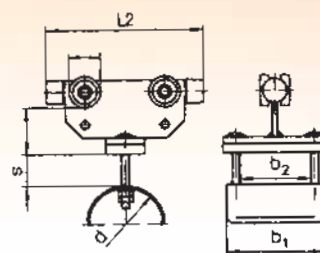

Fig.	Design	Load-carrying capacity P kg	Length 1 L1 mm	Length 2 L2 mm	Support width b mm	Radius d mm	30		40	
							23200	24100	Ident. No.	Order No.
	Ball bearing roller in galvanized steel. Plastic load-carrying part.	20	80	-	80	50	0020591	NO 23941	Not available	
		20	125	-	80	50	0020594	NO 23951	Not available	
		20	125	-	80	80	0020600	NO 23971	Not available	
A	Polyamide plain bearing roller, yellow. Plastic load-carrying part.	10	80	-	80	50	0020593	NO 23943	Not available	
		10	125	-	80	50	0020595	NO 23953	Not available	
		10	125	-	80	80	0020601	NO 23973	Not available	
B	Ball bearing roller in galvanized steel. Load-carrying part in galvanized steel sheet. Plastic support and half-nut.	20/32	80	-	80	50	0020514	NO 23261	0020679	NO 24240-80
		20/32	125	-	80	50	0020515	NO 23263	0020678	NO 24240-125
		20/32	125	-	80	80	0020522	NO 23271	0020680	NO 24241
C	Ball bearing roller in galvanized steel. Load-carrying part in galvanized steel sheet. Plastic support and half-nut, holes for strain relief.	20/32	100	-	80	50	0020516	NO 23265-100	0020681	NO 24242-100
		20/32	-	125	80	50	0020517	NO 23265-125	0020682	NO 24242-125
		20/32	100	-	80	80	0020523	NO 23275-100	0020683	NO 24243-100
D	Ball bearing roller in galvanized steel. Load-carrying part in galvanized steel. Support and small parts in galvanized steel. Rubber clamping piece; holes for strain relief.	20/32	100	-	100	80	0020541	NO 23330-105x100	0020659	NO 24210-100x100
		20/32	-	125	100	80	0020543	NO 23330-125x100	0020661	NO 24210-125x100
		20/32	100	-	160	80	0020542	NO 23330-105x160	0020660	NO 24210-100x160
		20/32	-	125	160	80	0020544	NO 23330-125x160	0020662	NO 24210-125x160
		20/32	135	-	100	80	0020545	NO 23330-140x100	0020663	NO 24210-135x100
		20/32	-	160	100	80	0020548	NO 23330-160x100	0020665	NO 24210-160x100
		20/32	135	-	160	80	0020546	NO 23330-140x160	0020664	NO 24210-135x160
		20/32	-	160	160	80	0020549	NO 23330-160x160	0020666	NO 24210-160x160
		20/32	175	-	100	80	0020550	NO 23330-180x100	0020667	NO 24210-175x100
		20/32	-	200	100	80	0020552	NO 23330-200x100	0020669	NO 24210-200x100
		20/32	175	-	160	80	0020551	NO 23330-180x160	0020668	NO 24210-175x160
		20/32	-	200	160	80	0020553	NO 23330-200x160	0020670	NO 24210-200x160

Cable trolleys length 1 without rubber buffer. Cable trolley length 2 with rubber buffer.

Collector trolleys for flat cables



A



B + C



D

Fig.	Design	Load-carrying capacity P kg	Length 1 L1 mm	Length 2 L2 mm	Support width b mm	Radius d mm	30		40		
							23200	Order No.	24100	Order No.	
A	Ball bearing roller in galvanized steel. Plastic load-carrying part.	20	125	-	80	50	0020597	NO 23956	-	-	
		20	125	-	80	80	0020602	NO 23976	-	-	
	Polyamide plain bearing roller, yellow. Plastic load-carrying part.		10	125	-	80	50	0020598	NO 23958	-	-
	10	125	-	80	80	0020603	NO 23978	-	-		
B	Ball bearing roller in galvanized steel. Load-carrying part in galvanized steel sheet. Plastic support and half-nut.	20	125	-	80	50	0020518	NO 23267	0020685	NO 24250	
		20	125	-	80	80	0020525	NO 23277	0020686	NO 24251	
C	Ball bearing roller in galvanized steel. Load-carrying part in galvanized steel sheet. Plastic support and half-nut, holes for strain relief.	20/32	100	-	80	50	0020519	NO 23268-100	0020687	NO 24252-100	
		20/32	-	125	80	50	0020520	NO 23268-125	0020688	NO 24252-125	
		20/32	100	-	80	80	0020526	NO 23278-100	0020689	NO 24253-100	
		20/32	-	125	80	80	0020527	NO 23278-125	0020690	NO 24253-125	
D	Ball bearing roller in galvanized steel. Load-carrying part in galvanized steel. Support and small parts in galvanized steel. Rubber clamping piece; holes for strain relief.	32	-	200	100	80	-	-	0020673	NO 24220-200x100	
		32	-	200	160	80	-	-	0020674	NO 24220-200x160	

Cable trolleys length 1 without rubber buffer. Cable trolley length 2 with rubber buffer.

End clamps for flat cables



A/B/C



D

Fig.	Design	Load-carrying capacity P kg	Length 1 L1 mm	Length 2 L2 mm	Support width b mm	Radius d mm	30		40	
							23200	Order No.	24100	Order No.
A/B/C	Load-carrying part in galvanized steel sheet.	20	75	-	80	50	0020521	NO 23269	0020521	NO 23269
		20	75	-	80	80	0020528	NO 23279	0020528	NO 23279
D	Load-carrying part in galvanized steel.	32	106	-	100	80	0020675	NO 24230-100x62	0020675	NO 24230-100x62
		2	106	-	160	80	0020676	NO 24230-160x62	0020676	NO 24230-160x62

Cable trolleys for round cables



A



B



Hole for strain relief

C



D

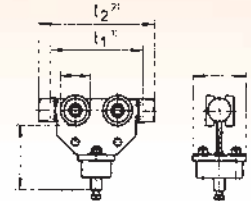
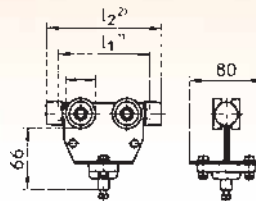
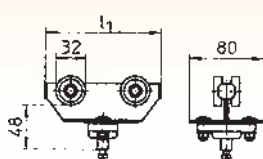
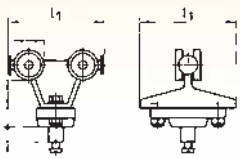

Fig.	Design	Appl. cable holder	Load-carrying capacity P	Length		Width b	30		40	
				L1	L2		23200	24100		
			kg	mm	mm	mm	Ident. No.	Order No.	Ident. No.	Order No.
	Ball bearing roller in galvanized steel. Plastic load-carrying part.	NO 20131	20	80	-	80	0020605	NO 23991	-	-
A	Plastic plain bearing roller, yellow. Plastic load-carrying part.	ditto	10	80	-	80	0020607	NO 23993	-	-
B	Ball bearing roller in galvanized steel. Load-carrying part in galvanized steel sheet. Plastic ball joint, yellow.	ditto	20/32	80	-	80	0020529	NO 23291	0020702	NO 24313-80
		ditto	20/32	125	-	80	-	-	0020701	NO 24313
C	Ball bearing roller in galvanized steel. Load-carrying part in galvanized steel sheet. Plastic ball joint, yellow. Holes for strain relief.	ditto	20/32	100	-	80	-	-	0020691	NO 24306-100
		ditto	20/32	-	125	80	0020530	NO 23291-125	0020692	NO 24306-125
D	Ball bearing roller in galvanized steel. Load-carrying part in galvanized steel. Plastic ball joint, yellow. Holes for strain relief.	ditto	32	100	-	55	-	-	0020695	NO 24310-100
		ditto	32	-	125	55	-	-	0020696	NO 24310-125
		ditto	32	-	160	55	-	-	0020697	NO 24310-160
		ditto	32	-	200	55	-	-	0020698	NO 24310-200

Length 1 without rubber buffer. Length 2 with rubber buffer.

Leaving technical changes!



Cable holder for screwing from below; see page H 25.

Collector trolleys for round cables



A

B + C

D

Fig.	Design	Appl. cable holder	Load-carrying capacity P	Length		Width	30		40	
				L1	L2		23200	24100		
			kg	mm	mm	mm	Ident. No.	Order No.	Ident. No.	Order No.
	Ball bearing roller in galvanized steel. Plastic load-carrying part.	NO 20131	20	125	-	80	0020608	NO 23996	-	-
A	Polyamide plain bearing roller, yellow. Plastic load-carrying part.	ditto	10	125	-	80	0020609	NO 23998	-	-
B	Ball bearing roller in galvanized steel. Load-carrying part in galvanized steel sheet. Plastic ball joint.	ditto	20/32	125	-	80	0020534	NO 23297	0020703	NO 24314
C	Ball bearing roller in galvanized steel. Load-carrying part in galvanized steel sheet. Plastic ball joint. Holes for strain relief.	ditto	32	-	100	80	-	-	0020693	NO 24207-100
		ditto	20/32	-	125	80	0020537	NO 23300-125	0020694	NO 24307-125
D	Ball bearing roller in galvanized steel. Load-carrying part in galvanized steel. Galvanized steel ball joint Holes for strain relief.	ditto	32	-	200	80	-	-	0020699	NO 24311

Length 1 without rubber buffer. Length 2 with rubber buffer.

End clamps for round cables



Fig.	Design	Appl. cable holder	Load-carrying capacity P	Length		Width	30		40	
				L1	L2		23200	24100		
			kg	mm	mm	mm	Ident. No.	Order No.	Ident. No.	Order No.
	Plastic load-carrying part, small parts made of galvanized steel.	NO 20131	20/32	-	-	-	0020536	NO 23299	0020700	NO 24312



Cable holder for screwing from below; see page H 25.

Cable trolley, collector trolley and end clamp for round cables



A + B



C + D

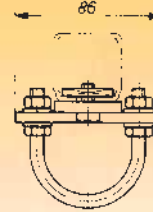
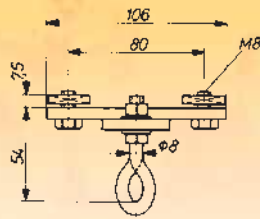

E

Fig.	Design	Appl. cable holder	Load-carrying capacity P	Length		Width b	Ident. No.			
				L1	L2		30	40		
							23200	24100		
		kg	mm	mm	mm	Ident. No.	Order No.	Ident. No.	Order No.	
A	Cable trolleys	NO 20133	20	80	-	74	0020531	NO 23293*	-	-
	Load-carrying part in galvanized steel sheet. Bracket, galvanized.	ditto	32	100	-	80	-	-	0020704	NO 24316-100*
		ditto	20/32	-	125	80	0020532	NO 23293-125	0020705	NO 24316-125
B	As above	ditto	32	100	-	86	-	-	0020709	NO 24320-100
	Load-carrying part in galvanized steel.	ditto	32	-	125	86	-	-	0020710	NO 24320-125
		ditto	32	-	160	86	-	-	0020711	NO 24320-160
		ditto	32	-	200	86	-	-	0020712	NO 24320-200
C	Collector trolleys	ditto	32	175	-	-	-	-	0020706	NO 24317-175*
	Design A.	ditto	32	-	200	-	-	-	0020707	NO 24317-200
D	Collector trolleys	ditto	32	-	200	80	-	-	0020713	NO 24321
	Design B.									
E	End clamp	ditto	32	-	-	-	0020535	NO 23298	0020708	NO 24318
		ditto	32	-	-	-	-	-	0020714	NO 24322



Length 1 without rubber buffer. Length 2 with rubber buffer.
* without rubber buffer

For related cable holders with mounting brackets, see page H 25.

Cable trolley upper parts

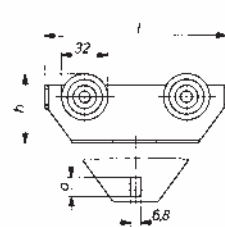
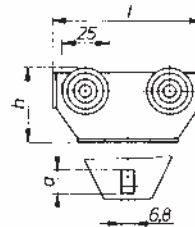
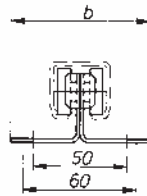
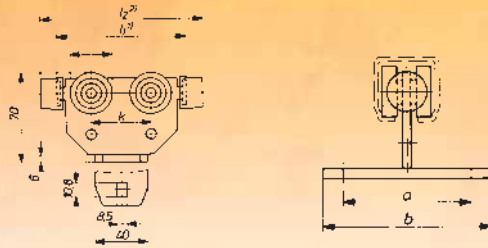

Fig.	Design	Load-carrying capacity P	Length		Width b	Height h	Ident. No.			
			L1	L2			30	40		
							23200	24100		
		kg	mm	mm	mm	mm	Ident. No.	Order No.	Ident. No.	Order No.
Ball bearing roller in galvanized steel.		20	80	-	74	40	0020512	NO 23258	-	-
		32	80	-	74	45	-	-	0020754	NO 24512-80
Load-carrying part in galvanized steel sheet.		20	125	-	80	45	0020513	NO 23259	-	-
		32	125	-	86	50	-	-	0020753	NO 24512

Leaving technical changes!

Special trolley



Load-carrying capacity

30

40

Fig.	Design	P	L1	L2	a	b	h	Ident. No.	Order No.	Ident. No.	Order No.
		kg	mm	mm	mm	mm	mm	23200		24100	
		32	135	160	80	106	70	-	-	0020750	NO 24510-160x100

Ball bearing roller in galvanized steel.
Load-carrying part in galvanized steel sheet.

Length 1 without rubber buffer. Length 2 with rubber buffer.

Cable trolleys

1

2

3

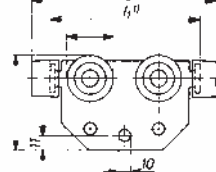
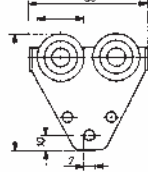
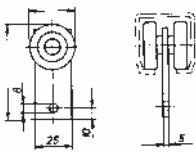

Bearing Accessories Length Height

30

40

Fig.	Design	Bearing	Accessories	L	h	Ident. No.	Order No.	Ident. No.	Order No.
				mm	mm	23200		24100	
1	2-rollers Load-carrying part: 23200 plastic 24100 steel, galv.	Ball bearings	Without	-	56,5/66	0020563	NO 23361	0020718	NO 24330
			S hook	-	56,5/66	0020565	NO 23363	0020720	NO 24332
			Webbing	-	56,5/66	0020567	NO 23365	0020722	NO 24334
			Ring	-	56,5/66	0020569	NO 23367	-	-
1	2-rollers Load-carrying part: Plastic	Plain bearing	Without	-	56,5/66	0020564	NO 23362	0020719	NO 24331
			S hook	-	56,5/66	0020566	NO 23364	0020721	NO 24333
			Webbing	-	56,5/66	0020568	NO 23366	0020723	NO 24335
			Ring	-	56,5/66	0020570	NO 23368	-	-
2	4-rollers Load-carrying part: Steel sheet, galvanized.	Ball bearings	Without	80	72/80	0020554	NO 23351	0020715	NO 24323
			S hook	80	72/80	0020557	NO 23353	0020716	NO 24324
			Webbing	80	72/80	0020558	NO 23355	0020717	NO 24325
			Carabiner	80	72/80	0020572	NO 23373	-	-
3	4-rollers Load-carrying part: Steel, galv.	Ball bearings	Without	100	43	-	-	-	-
			Without	100	64	-	-	0020724	NO 24340-100
			Rubber buffer	125	64	-	-	0020725	NO 24340-125
			S hook	100	43	-	-	-	-
			S hook	100	64	-	-	0020729	NO 24342-100
			S hook/R stop	125	64	-	-	0020730	NO 24342-125

Length 125 with rubber buffer.

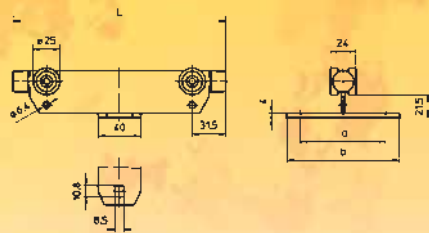

Load-carrying capacity Length 1 Length 2

30

40

23200

24100

Design	P	L1	L2	a	b	h	Ident. No.	Order No.	Ident. No.	Order No.
Ball bearing roller in galvanized steel. Load-carrying part in galvanized steel.	32	140	–	80	106	70	0028920	NO 23308-140x100	–	–
	32	–	160	80	106	70	0028921	NO 23308-160x100	–	–
	32	180	–	80	106	70	0028922	NO 23308-180x100	–	–
	32	–	200	80	106	70	0028923	NO 23308-200x100	–	–
	32	230	–	80	106	70	0028924	NO 23308-230x100	–	–
	32	–	250	80	106	70	0028925	NO 23308-250x100	–	–



Bearing Load-carrying capacity Accessories Length 1 Height

30

40

23200

24100

Design	kg	mm	mm	Ident. No.	Order No.	Ident. No.	Order No.
Ball bearing roller in galvanized steel. Load-carrying part in galvanized steel.	20	80	25	0020556	NO 23352-1ST	–	–

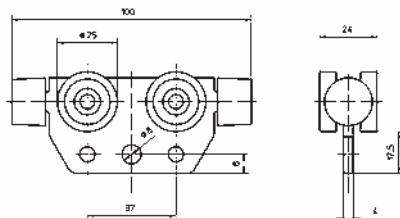

Load-carrying capacity Length 1 Length 2 Height

30

40

23200

24100

Design	P	L1	L2	s	h	Ident. No.	Order No.	Ident. No.	Order No.
Ball bearing roller in galvanized steel. Load-carrying part in galvanized steel.	20	80	–	4	43	0020561	NO 23357-80	–	–
	20	–	100	4	43	0020559	NO 23357-100	–	–
	20	180	–	4	43	0020560	NO 23357-180	–	–
	20	–	200	4	43	0028167	NO 23357-200	–	–

Tool trolley

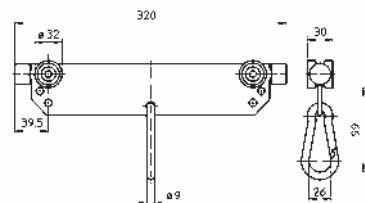

Load-carrying capacity Length 1 Length 2 Height

30

40

23200

24100

Design	P	L1	L2	s	h	Ident. No.	Order No.	Ident. No.	Order No.
Ball bearing roller in galvanized steel. Load-carrying part in galvanized steel.	50	–	320	5	64	–	–	0026768	NO 24348-320

Leaving technical changes!

Cable holders

Materials: CH size 16, 25, 36 = plastic.
LH size 50 = Aluminum.
Small parts galvanized.

Working temperature: -30°C to +80°C.

Application: The cable holders are intended for use with round cables and hoses. One or more different cable holder(s) can be attached under the cable trolley. It must be ensured that the largest holder is attached to the top.



	Cable Ø	Material	Ident. No.	Order No.
	mm			
For screw fastening from below	10 – 16	KU	0020337	NO 20131-16
	17 – 25	KU	0020338	NO 20131-25
	26 – 36	KU	0020339	NO 20131-36
	37 – 50	ALU	0020340	NO 20131-50
	51 – 63	ALU	0020341	NO 20131-63
With mounting bracket	10 – 16	KU	0020343	NO 20133-16
	17 – 25	KU	0020344	NO 20133-25
	26 – 36	KU	0020345	NO 20133-36
	37 – 50	ALU	0020346	NO 20133-50
	51 – 63	ALU	0020347	NO 20133-63

Cable trolleys



Materials: Plastic load-carrying part.
Bearings, see table.

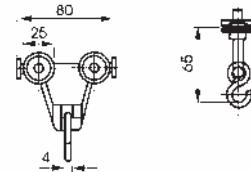

30

40

Design	Ident. No.	Order No.	Ident. No.	Order No.
Plain bearing, polyamide	0020511	NO 23254	0020740	NO 24504
Plain bearing, w/ S hook	0020589	NO 23900	-	-

Brackets

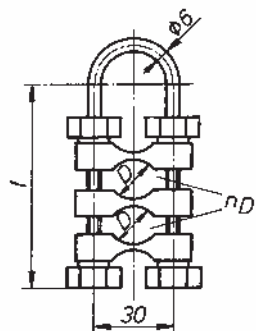

Materials: Bracket, galvanized.
Clamping parts, plastic.

Number of openings	Total of all single Øs		Ident. No.	Order No.
	mm	max.		
1	8 – 18		0020348	NO 20137-1x18
1	8 – 22		0020349	NO 20137-1x22
2	32		0020350	NO 20137-2x32
3	30		0020351	NO 20137-3x30
3	50		0020352	NO 20137-3x50
4	48		0020353	NO 20137-4x48

More bracket types on request.

Special accessories

Note!

Other trolleys, accessories, etc., also in the area of the suspension tracks, starting on page H 38.



Cross beam trolleys for control elements/self-assembly

Materials: Steel, galvanized, cross beam, yellow coated.

Trolley length	Load-carrying capacity	30		40	
		Ident. No.	Order No.	Ident. No.	Order No.
500	40dN	0020991	NO 47200-500	50dN	0020994
630	40dN	0020992	NO 47200-630	50dN	0020995
800	40dN	0020993	NO 47200-800	50dN	0020996

Brackets for suspending spring balancers, etc. can be ordered.

NO 40011-60x8

S hook

Materials: Steel, galvanized.
Weight: 0.010 kg

Ident. No.	0020336
Order No.	NO 20118-45x4

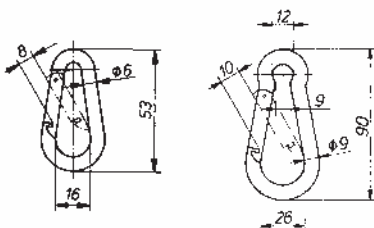
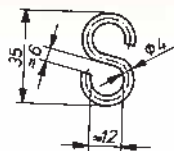

Carabiner snap hook

Materials: Steel, galvanized.
Weight: 0.025 kg

Ident. No.	0020397
Order No.	NO 20216-90x9

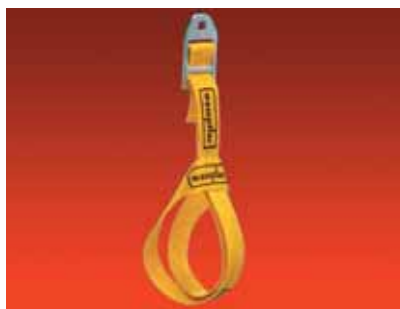

Webbing

Materials: Clasp: Steel, galvanized.
Belt: Diols.

Ident. No.	0020169	0020168
Order No.	NO 20117-80	NO 20117-160



Cable clamp for round cables

Materials: Bracket: Plastic.
Small parts: Steel, galvanized.

Cable Ø d	Ident. No.	Order No.
mm		
10	0020162	NO 20111-10
12.5	0020163	NO 20111-12.5
16	0020164	NO 20111-16
20	0020165	NO 20111-20

Cable clamp for flat cables

Materials: Bracket: Plastic.
Small parts: Steel, galvanized.

Ident. No.	0020167
Order No.	NO 20114

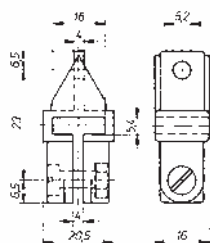

Special accessories



Distance piece

For suspending track holding clamps to C-rails NO 23200 and NO 24100.

Use if, e.g., rows of lights or ventilation pipes or ducts do not allow for direct attachment of the crane track to the ceiling.

Materials: Steel, coated with RAL 7016 anthracite.

Permissible load: For NO 40241 160 daN.
For NO 40242 250 daN.

For track holding clamp to C-rail	h	a	Weight	Ø d	30		Weight	Ø d	40	
					23200	24100			23200	24100
	mm	mm	kg	mm	Ident. No.	Order No.	kg	mm	Ident. No.	Order No.
Distance piece	250	60	0.735	M8	0028926	NO 40241-0250	0.755	M10	0028929	NO 40242-0250
	500	60	1.14	M8	0028927	NO 40241-0500	1.165	M10	0028930	NO 40242-0500
	1000	60	1.185	M8	0028928	NO 40241-1000	1.965	M10	0028931	NO 40242-1000

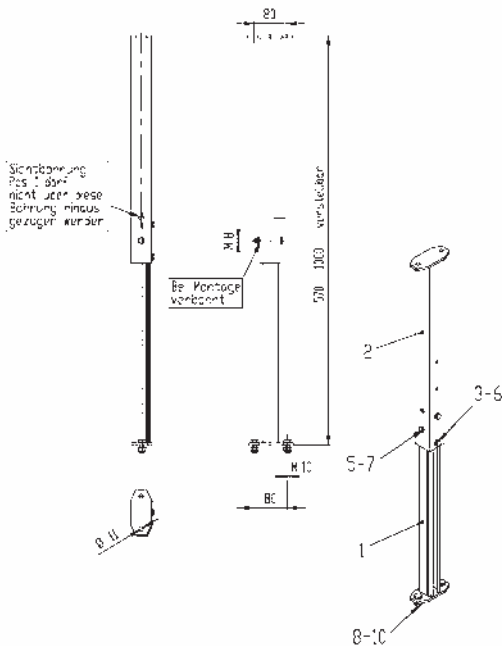

Materials: Steel, coated with RAL 7016 anthracite.

Distance piece, adjustable

For suspending track holding clamps to C-rails NO 24100.

Set the distance piece to the desired suspension height and secure in place using clamping screws 1. Drill the hole for locking screw 2 and install the locking screw. The dimension "h" must not exceed the maximum specified value.

Can be adapted to suit lower heights by shortening of both parts.

For track holding clamp to C-rail	h (max./min.)	Minimum overlap	Permissible load	Weight	40	
					24100	Ident. No.
	mm	mm	daN	kg	Ident. No.	Order No.
Distance piece	1000/570	110	200	2.3	0020828	NO 40243-1

One- and two-rail track

With equipment cart (EBG), tool carrier cart (EBW, ZBW) or spider assembly (ZBD).

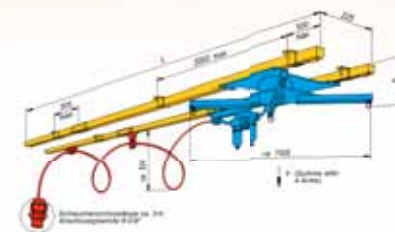
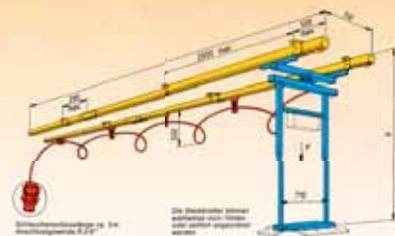
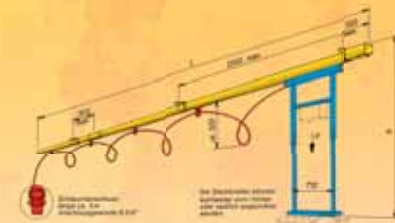
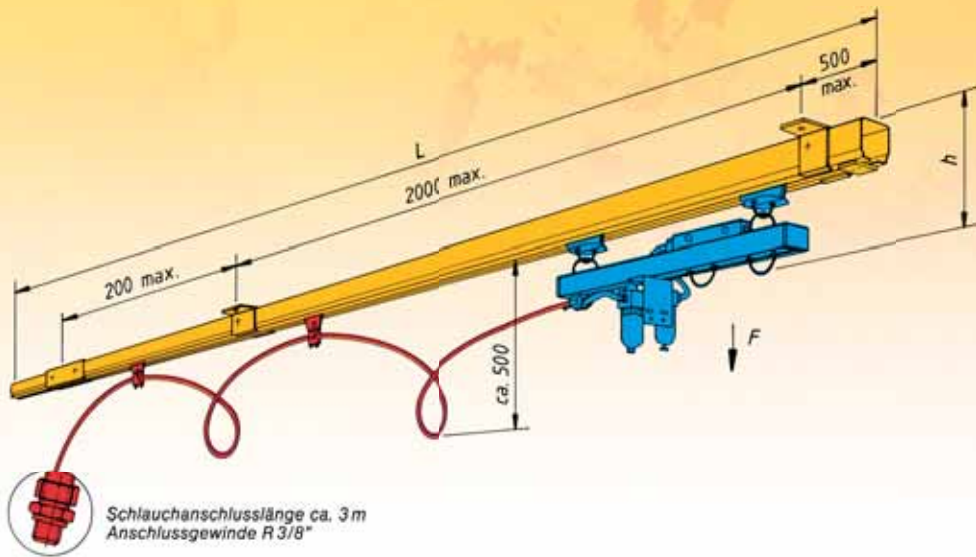

Design		A	B	C
Compressed air connection:	2 x 3/8"	x	-	x
Electrical connection:	4/2x220 V~	x	x	-
Perm. current load:	10/16 A	x	x	-
Maintenance unit:	R 3/8"	x	-	x
Connecting thread:	R 3/8"	x	-	x
Compressed air hose, nominal size:	9.5 mm	x	-	x

Order No.	Track profile		Load-carrying capacity F daN	Rail track length L m	Height h mm	Remark
NO EBG 47311-□□□	30	23200	40	02, 04, 06, 08, 10, 12, 16, 20 (Standard lengths)	185	Reductions R 3/8" a x R 1/4" for compressed air included with the cart.
NO EBG 47411-□□□	40	24100	63		215	
NO ZBW 47431-□□□	40	24100	50	ditto	1650-2800	ditto
NO ZBW 47432-□□□	40	24100	63	ditto	1700-2920	ditto
NO ZBD 47352-□□□	30	23200	50 max. 20 per arm	03, 04, 06, 08, 10, 12, 16, 20 (Standard lengths)	215	ditto The load-carrying capacities apply to the spider assembly. Spider assemblies with electrical connections can also be retrofitted for HF tools.
NO ZBD 47452-□□□	40	24100	50 max. 20 per arm		245	

Leaving technical changes!

Order No.: NO 47... - □□□

Track type
Rail track length L (m)
Design (A, B, C)

One- and two-carrier equipment crane

With equipment cart (EGG), tool carrier cart (EGW, ZGW) or spider assembly (ZGD).

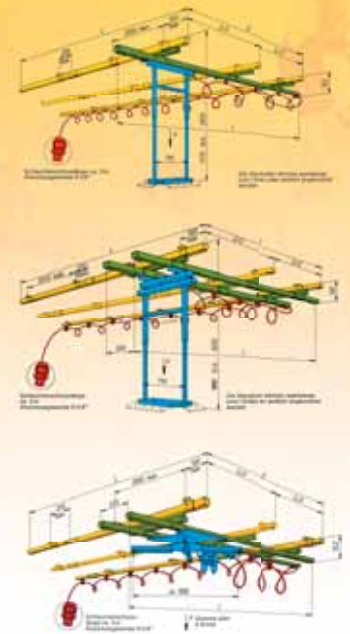
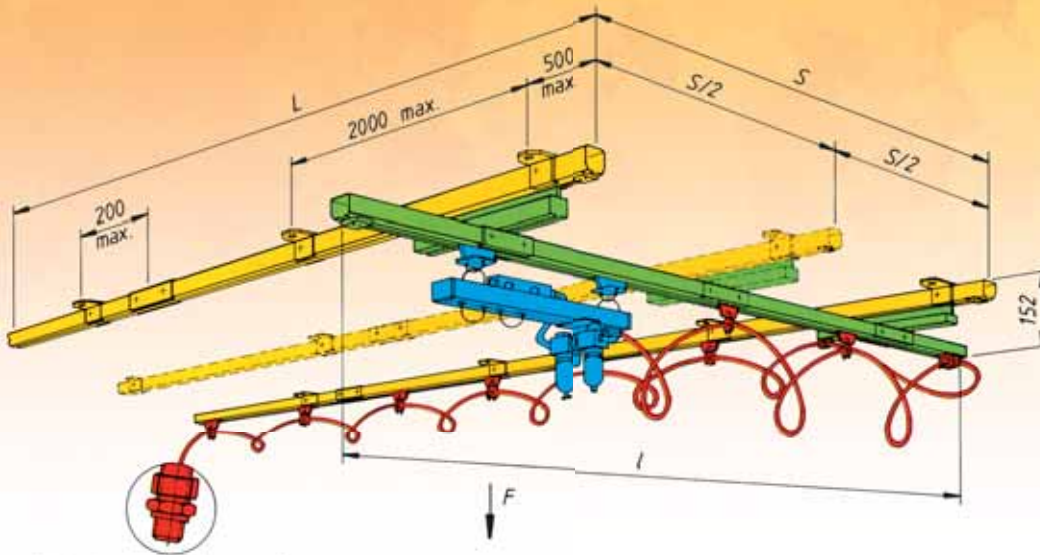

Schlauchanschlusslänge ca. 3m
Anschlussgewinde R 3/8"



Design

Compressed air connection:	2 x 3/8"	x	-	x	x
Electrical connection:	4/2x220 V~	x	x	-	x
Perm. current load:	10/16 A	x	x	-	x
Maintenance unit:	R 3/8"	x	-	x	x
Connecting thread:	R 3/8"	x	-	x	x
Compressed air hose, nominal size:	9.5 mm	x	-	x	x
Fixed storage boxes, size 5:	6 pc.	-	-	-	x



Order No.	Track profile	Load-carrying capacity F	Crane track length L	Equipment crane length L	Remark
		daN	m	mm	
NO EGG 47415-□□□	40	24100	50	04, 06, 08, 10, 12, 16, 20 (Standard lengths)	3, 4, 5, 6, (Standard lengths) Reductions R 3/8" a x R 1/4" i for compressed air included with the cart.
NO EGW 47435-□□□	40	24100	50	ditto	ditto
NO ZGW 47436-□□□	40	24100	63	ditto	ditto
NO ZGD 47456-□□□	40	24100	50 max. 20 per arm	ditto	ditto The load-carrying capacities apply to the spider assembly. Spider assemblies with electrical connections can also be retrofitted for HF tools.

Order No.: NO 47... □□ x □ - □

Carrier type
Crane track length L (m)
Equipment crane length I (m)
Design (A, B, C, D)

Running gears for equipment cranes

Medium-weight design with horizontal guide rollers.



Running gear for special purposes.
Materials:
Bright steel

Running gear for single-support equipment crane.
Materials:
Steel, galvanized.

Running gear for double-support equipment crane.
Materials:
Steel, galvanized.



C-rail	NO 145005		NO 146005		NO 147005		NO 148005		
Technical data	Ident. No.	Order No.	Ident. No.	Order No.	Ident. No.	Order No.	Ident. No.	Order No.	
	L2	0028981	NO 43612-370	0028982	NO 43622-400	0028983	NO 43632-560	0028984	NO 43642-560
	L2	0028985	NO 43614-450	0028986	NO 43624-475	See heavy-duty design.			
	L2	0028989	NO 43616-450	0028990	NO 43626-475				
Dimensions (mm)	L3	200		200					
	d1	32		40		52		62	
	d2	32		42		52		68	
	h1	28		25		16		18	
	h2	75		80		-		-	
	S	5		6		8		8	
	C	125		160		200		250	

Running gears for equipment cranes

Heavy-duty design with horizontal guide rollers.



Running gear for single-support equipment crane.
Materials: Steel, galvanized.

Running gear for double-support equipment crane.
Materials: Steel, galvanized.

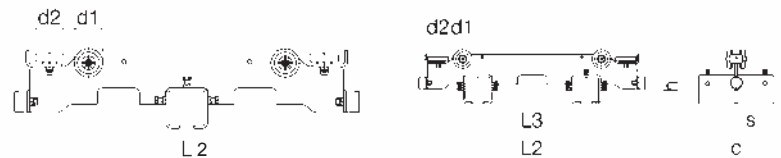

Technical data	Ident. No.	Order No.	Ident. No.	Order No.	
	L2	0028969	NO 43653-500	0028970	NO 43663-500
	L2	0028979	NO 43655-630	0028980	NO 43665-630
Dimensions (mm)	L3	See medium weight design.		360	360
	d1			52	62
	d2			52	68
	h2			86	106
	S			8	8
	C			200	250
Max. wheel pressure (daN) R1/R2		200/200		320/320	

Leaving technical changes!

Wall-mounted swivel arm

With equipment cart (WSG), spider assembly (ZWD).

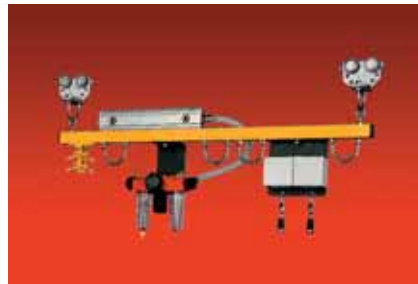
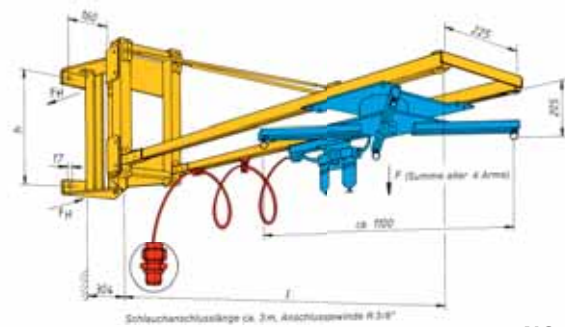
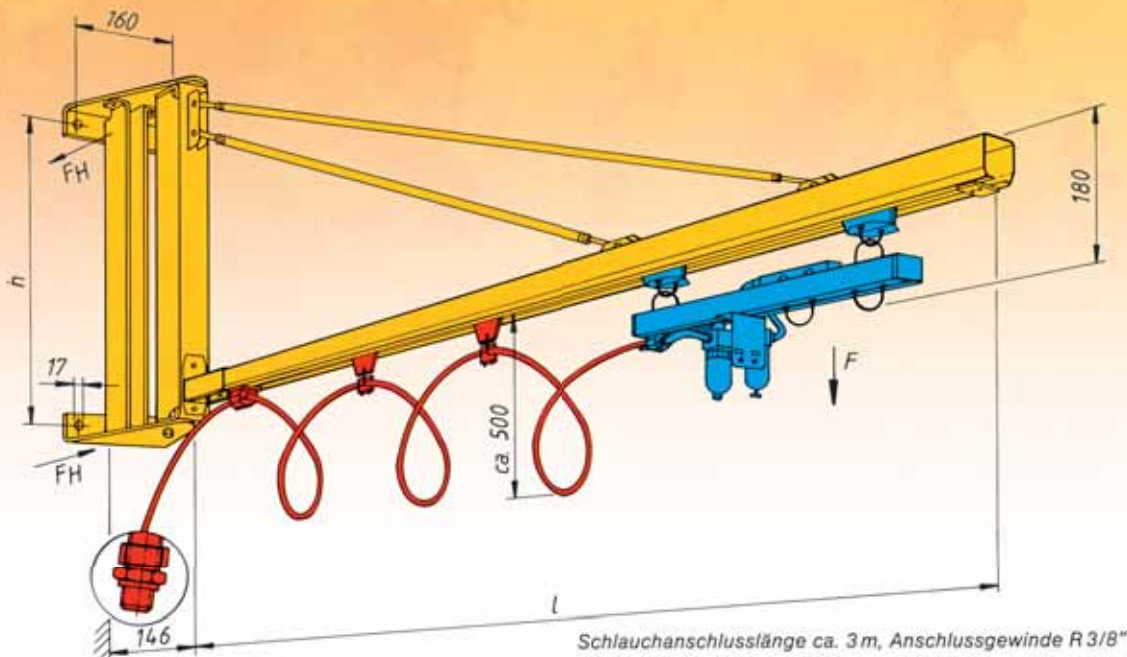

Design

Compressed air connection:	2 x 3/8"
Electrical connection:	2x220 V~
Perm. current load:	10/16 A
Maintenance unit:	R 3/8"
Connecting thread:	R 3/8"
Compressed air hose, nominal size:	9.5 mm
Equipment cart length:	mm

NO 47232

A

x

NO 47222

B

-

NO 47205

C

x

Compressed air connection:	2 x 3/8"	x	-	x
Electrical connection:	2x220 V~	x	x	-
Perm. current load:	10/16 A	x	x	-
Maintenance unit:	R 3/8"	x	-	x
Connecting thread:	R 3/8"	x	-	x
Compressed air hose, nominal size:	9.5 mm	x	-	x
Equipment cart length:	mm	800	630	630

Order No.	Design	Track profile	Load-carrying capacity F daN	Arm length L mm	L	h
					mm	mm
NO 47413 - <input type="checkbox"/> <input type="checkbox"/>	WSG	24100	20	2, 3, 4, 5, 6 (Standard lengths)	2	340
NO 47417 - <input type="checkbox"/> <input type="checkbox"/>	WSG	24100	50	ditto	3	465
					4	590
					5	720
					6	840
NO 47457 - <input type="checkbox"/> <input type="checkbox"/>	ZWD	24100	50	3, 4, 5, 6 (Standard lengths)	3	465
					4	590
					5	720
					6	840

Order number: NO 47... -
Order example: NO 47413 - 3 A

Load-carrying capacity F (20, 50 daN) (design type)
Arm length l (m)
Equipment cart configuration (A,B,C)

Swivel arm, carrying capacity 20 – 50 – daN

Swivel range 180° to 270°.

With wall bracket for wall mounting - without wall bracket for column-mounted configuration.

For self-assembly in individual applications.

Intermediate arm lengths are available on request.



40

Track profile C-rail NO 24100

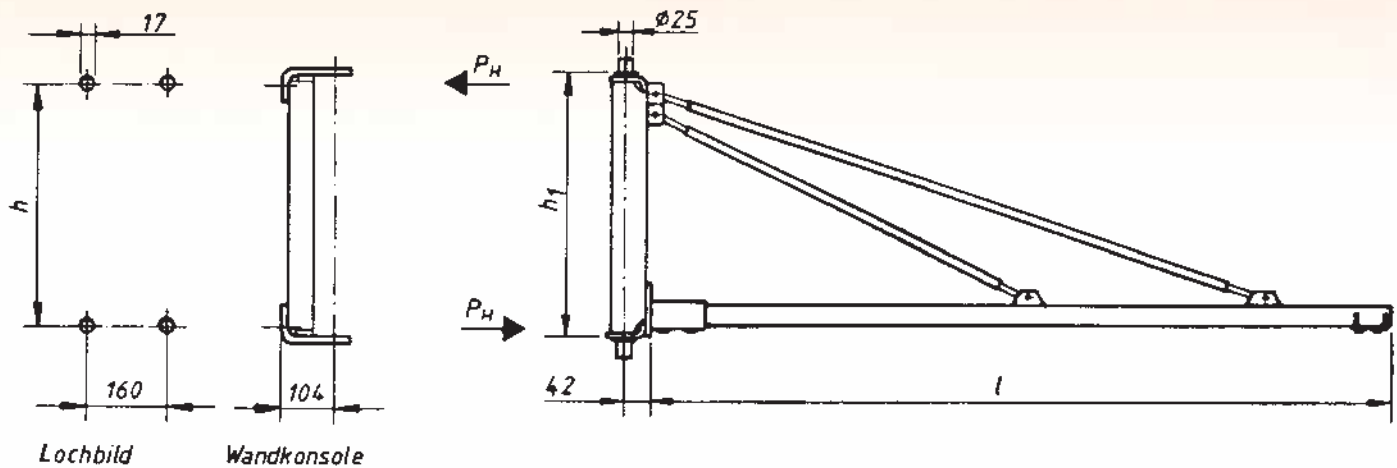
Design: Arm galvanized – bracket and beam coated, RAL 7016 anthracite.



Higher loads can be found starting on page H 57.

	With wall bracket		For column without wall bracket		Load-carrying capacity daN	Arm profile	Dimensions			PH max. daN	Weight with bracket kg	Wall bracket weight alone kg	
	Ident. No.	Order No.	Ident. No.	Order No.			l mm	h mm	hl mm				
Swivel arms	0020878	NO 42211-2	0020904	NO 42213-2	20		2000	340	375	150	16	9.1	
	0020879	NO 42211-3	0020905	NO 42213-3	20		3000	465	500	180	23	11	
	0020880	NO 42211-4	0020906	NO 42213-4	20		4000	590	625	200	28	12.8	
	0020881	NO 42211-5	0020907	NO 42213-5	20		5000	720	755	225	36	14.4	
	0020882	NO 42211-6	0020908	NO 42213-6	20		6000	840	875	235	40	16	
Swivel arms	0020844	NO 42201-2	0020954	NO 42203-2	50		2000	340	375	330	16	9.1	
	0020845	NO 42201-3	0020955	NO 42203-3	50		3000	465	500	380	23	11	
	0020846	NO 42201-4	0020956	NO 42203-4	50			4000	590	625	455	41	12.8
	0020847	NO 42201-5	0020957	NO 42203-5	50			5000	720	755	490	51	14.4
	0020848	NO 42201-6	0020958	NO 42203-6	50			6000	840	875	530	61	16

Every order number also includes an axle support and an end stop.

Swivel arm, carrying capacity 20 – 50 – daN

Swivel range 180° to 270°.

With wall bracket for wall mounting - without wall bracket for column-mounted configuration.

Completely equipped with: 1 tool trolley with Carabiner snap hooks, cable trolley and end clamp, for seating any hose packages up to a diameter of 80 mm (also available up to Ø 160 mm), e.g., gas, water, or air hoses.

40

Track profile C-rail NO 24100

Design: Arm galvanized – bracket and beam coated, RAL 7016 anthracite.

No intermediate arm lengths are available.

0020733	NO24344-125x080	Cable trolleys
0026768	NO24348-320	Tool trolley
0020399	NO20220-80	End clamp with belt strap

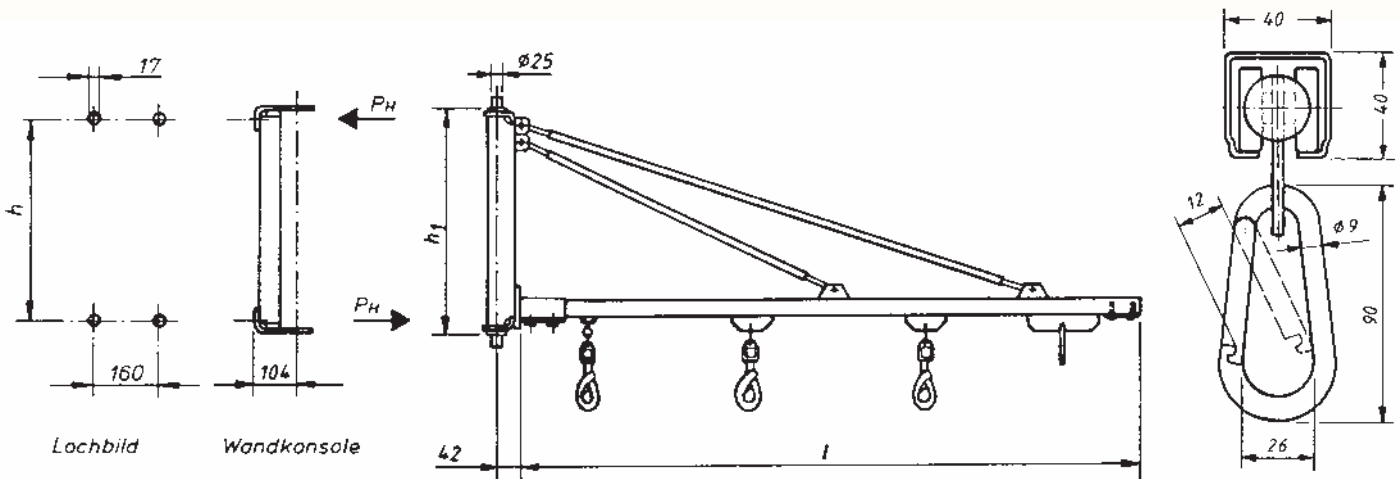

	With wall bracket		For column without wall bracket		Load-carrying capacity daN	Arm profile	Dimensions			PH max. daN	No. of cable trolleys	Weight with bracket kg
	Ident. No.	Order No.	Ident. No.	Order No.			l mm	h mm	hl mm			
Swivel arms	0020883	NO 42212-2	0020909	NO 42214-2	20	□	2000	340	375	155	1	17
	0020884	NO 42212-3	0020910	NO 42214-3	20		3000	465	500	190	2	25
	0020885	NO 42212-4	0020911	NO 42214-4	20		4000	590	625	205	3	30
	0020902	NO 42212-5	0020912	NO 42214-5	20		5000	720	755	235	4	40
	0020903	NO 42212-6	0020913	NO 42214-6	20		6000	840	875	250	5	45
Swivel arms	0020849	NO 42202-2	0020859	NO 42204-2	50	□	2000	340	375	335	1	17
	0020850	NO 42202-3	0020860	NO 42204-3	50		3000	465	500	385	2	25
	0020851	NO 42202-4	0020874	NO 42204-4	50		4000	590	625	465	3	45
	0020852	NO 42202-5	0020875	NO 42204-5	50		5000	720	755	505	4	55
	0020853	NO 42202-6	0020876	NO 42204-6	50		6000	840	875	545	5	65

Every order number also includes an axle support and an end stop.

Columns for swivel arms

Load-carrying capacity

20 – 50 daN

Swiveling range 270°.

Construction: primed.

- RAL 8902 red-brown.

- Alternative: RAL 1602 gray-green or RAL 7032 pebble gray.

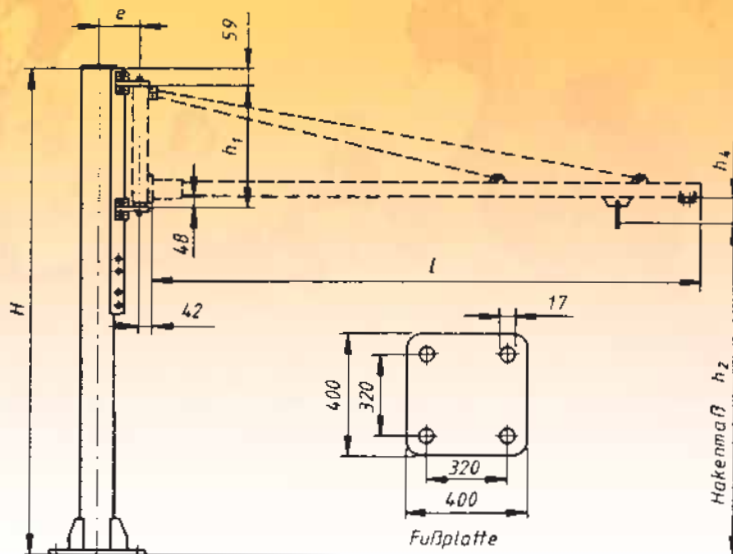

Higher loads can be found starting on page H 57.

Ident. No.	Order No.	Tube-Ø (St 37-2) mm	H mm	Load-carrying capacity of the swivel arm daN	Suitable swivel arm types	Dimensions			Weight kg
						e mm	h4 mm	h5 mm	
0020935	NO 42906-3	133.4 x 4	3000	20	NO 42213-...	162	95	-	58
0020936	NO 42906-4	133.4 x 4	4000	20	NO 42214-...	162	95	-	69
0020937	NO 42907-3	193.7 x 5.6	3000	50	NO 42203-...	195	95	136	109
0020938	NO 42907-4	193.7 x 5.6	4000	50	NO 42204-...	195	95	136	109

Dimensions depend on swivel arm type.

Column height H mm	Projection l mm	Installation dimension at		 mm	Max. tensile force Z per screw for arm loads	
		Hook dimension at 20/50 daN h2 mm	20/50 daN h1 mm		20 daN daN	50 daN daN
3000	2000	2520	375	600	85	210
3000	3000	2395	500	700	145	330
3000	4000	2270	625	800	205	470
3000	5000	2140	755	900	265	625
3000	6000	2020	875	1000	340	780
4000	2000	3520	375	600	85	210
4000	3000	3395	500	700	145	330
4000	4000	3270	625	800	205	470
4000	5000	3140	755	900	265	625
4000	6000	3020	875	1000	340	780

Tie rod set: Anchor screw length 320 mm, M16
(4 tie rods with nuts and lock washers).

Order number: NO 40121-320x16

A foundation template is also available for casting the tie rods.

Order number: Foundation template NO 42909

Column-mounted swivel arm

With equipment cart (SSG), spider assembly (ZSD).

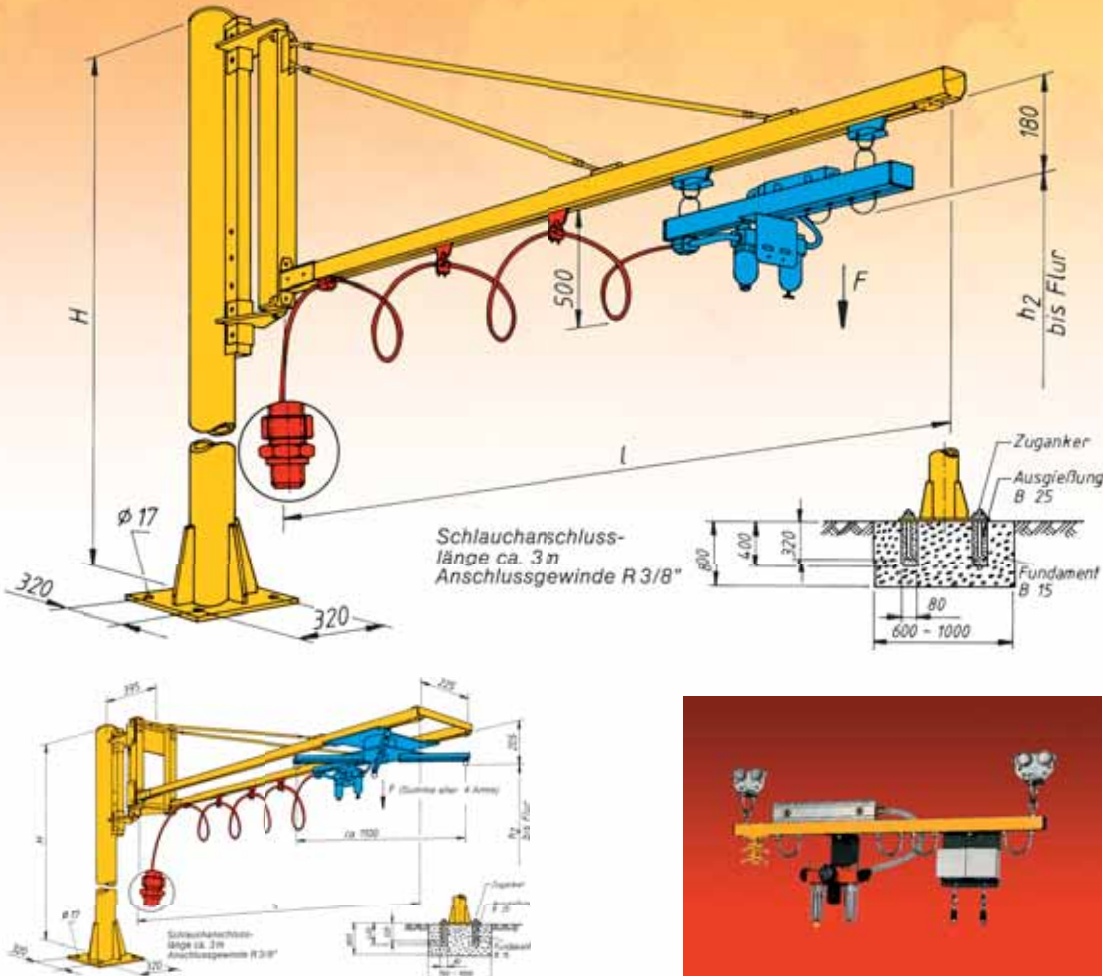

Design

		A	B	C
Compressed air connection:	2 x 3/8"	x	-	x
Electrical connection:	2x220 V~	x	x	-
Perm. current load:	10/16 A	x	x	-
Maintenance unit:	R 3/8"	x	-	x
Connecting thread:	R 3/8"	x	-	x
Compressed air hose, nominal size:	9.5 mm	x	-	x
Equipment cart length:	mm	800	630	630

Order No.	Design	Track profile	Load-carrying capacity F	Arm length L	Column height h	Hook dimension h 2 mm column		
						l	3 m	4 m
			daN	mm	m	m		
NO 47414 - <input type="checkbox"/> <input type="checkbox"/>	SSG	24100	20	2, 3, 4, 5, 6 (Standard lengths)	3, 4 (Standard lengths)	2	2435	3453
						3	2310	3310
						4	2185	3185
						5	2055	3055
NO 47418 - <input type="checkbox"/> <input type="checkbox"/>	SSG	24100	50	ditto	ditto	6	1935	2935
NO 47458 - <input type="checkbox"/> <input type="checkbox"/>	ZSD	24100	50 (20 max. per arm)	3, 4, 5, 6 (Standard lengths)	ditto	3	2280	3280
						4	2155	3155
						5	2025	3025
						6	1905	2905

Order number: NO 47... -
 Order example: NO 47414 - 4 x 3 A

Load-carrying capacity (design type)
 Arm length l (m)
 Column height (m)
 Equipment cart configuration (A,B,C)

Workbench apparatus with equipment cart

and power supply, for table or floor assembly **Abbreviation: WAG**

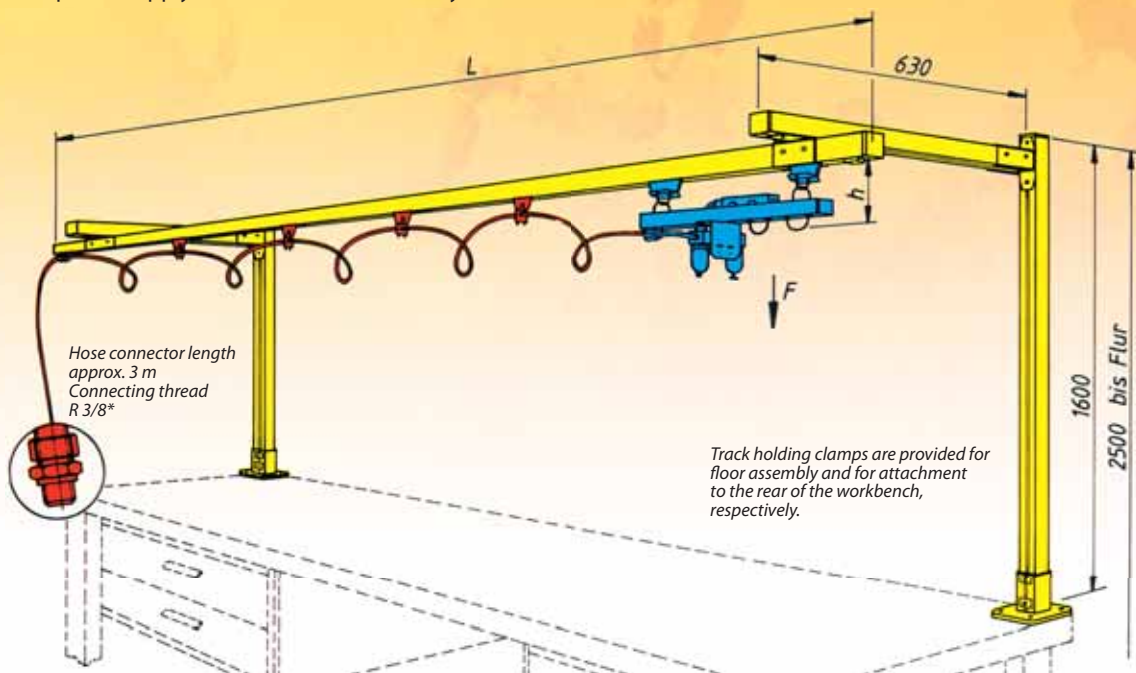

Equipment cart



Equipment cart configuration

Design A

Compressed air connection: 2 x 3/8"
 Electrical connection: 2x220 V~
 Perm. current load: 10/16 A
 Maintenance unit: R 3/8"
 Connecting thread: R 3/8"
 Compressed air hose, nominal size: 9.5 mm
 Equipment cart length: 800 mm

Design B

Electrical connection: 2x220 V~
 Perm. current load: 10/16 A
 Equipment cart length: 630 mm

Design C

Compressed air connection: 2 x 3/8"
 Maintenance unit: R 3/8"
 Connecting thread: R 3/8"
 Compressed air hose, nominal size: 9.5 mm
 Equipment cart length: 630 mm

Rail 30
 Rail 40

NO47232
 NO47282

NO47222
 NO47272

NO47205
 NO47255

Reductions R 3/8"a x R 1/4"i for compressed air included with the cart.

Order No.	Track profile	Load-carrying capacity at support distance F	Rail track length L	Equipment crane length L	Installation height		
					h	Tisch Floor	
Table assembly NO 47319 - □□, □□	30	23200	01,5	2	155	1600	-
Floor assembly NO 47310 - □□, □□						-	2500
Table assembly NO 47419 - □□, □□	40	24100	04,0	3	175	1600	-
Floor assembly NO 47410 - □□, □□						-	2500

Order No.: WAG NO 47... - □□, □□

Table/floor assembly, track profile, load-carrying capacity
 Rail track length L (m)
 Equipment cart configuration (A, B, C)

Order No. example: WSG NO 47419 - 02,5 B

Leaving technical changes!

Swivel arms with tool carrier carts

For wall, table and floor assembly.

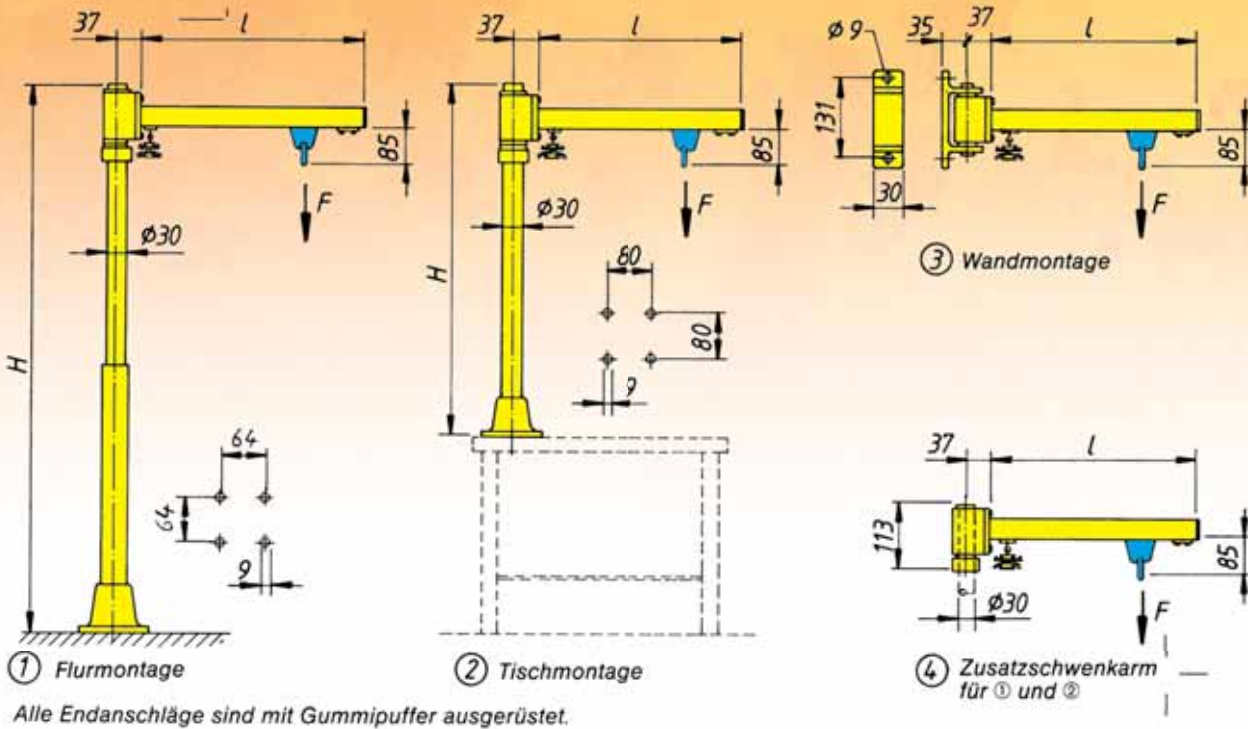

Ident. No.	Order No.	Fig.	Track profile	Load-carrying capacity F daN	Dimensions		Weight kg
					H mm	l mm	
					Floor assembly		
0020980	NO 44613-0630	①	30	16	1600 – 2500	630	11.2
0020981	NO 44613-1000			10	adjustable	1000	11.7
					Table assembly		
0020978	NO 44612-0630	②		16	1600	630	7.2
0020979	NO 44612-1000			10		1000	7.7
					Wall assembly		
0020982	NO 44622-0630	③	23200	20	-	630	3.5
0020983	NO 44622-1000			16		1000	4
					Additional swivel arm		
0020976	NO 44602-0630	④		16	-	630	3
0020977	NO 44602-1000			10		1000	3.5



Additional swivel arm

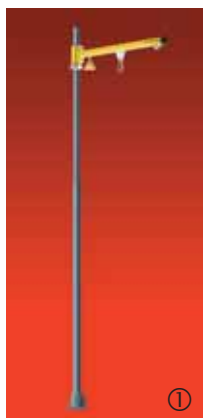

①

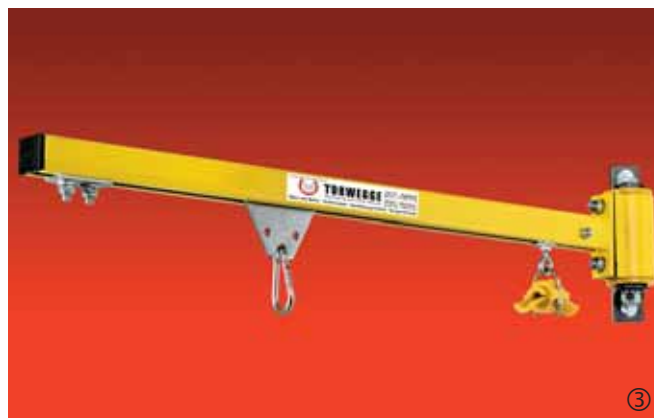

Swivel arm with wall bracket

③

Suspension tracks



Overhead conveyor system with Müsing spider assembly.



Our manual suspension tracks are also suitable for small and medium-sized trade companies. They are particularly distinguished by:

- Targeted material flow.
- Shorter transport and handling time.
- Larger ground clearance.
- Modular system: You can "start small" and expand the system at any time.
- Low investment costs.

- **Circular conveyor "Power & Free".**
- **Overhead twin-rail chain conveyors can also be provided.**

Give us a call!



JAB Anstötz marshaling area.

We put things in motion

Product similar to illustrations!

Suspension track - support spacing

Determining tolerable support spacing (simplified calculation method).

Basis for calculations:

1. Carrier on 2 supports, with distributed loading that is symmetric with respect to the center of the carrier.
2. The permissible deflection from the distributed load and dead weight of the rail = $l_A \cdot 1/500$.
3. $\delta_{ball} = 100 \text{ N/mm}^2$, without consideration of the flange stress.

A wide variety of loading cases occur within an overhead conveyor system. Individual loads are transported. These are held up in buffer sections to form line loads. "Empty suspension gear" is transported between unloading and loading stations. Therefore, quite different support spacing can be selected within a system. This means that the permissible support spacing should be calculated for each individual case based on the static values of the rails. **It is advisable to provide us with the design order to achieve an optimum layout.**

Distributed load diagram

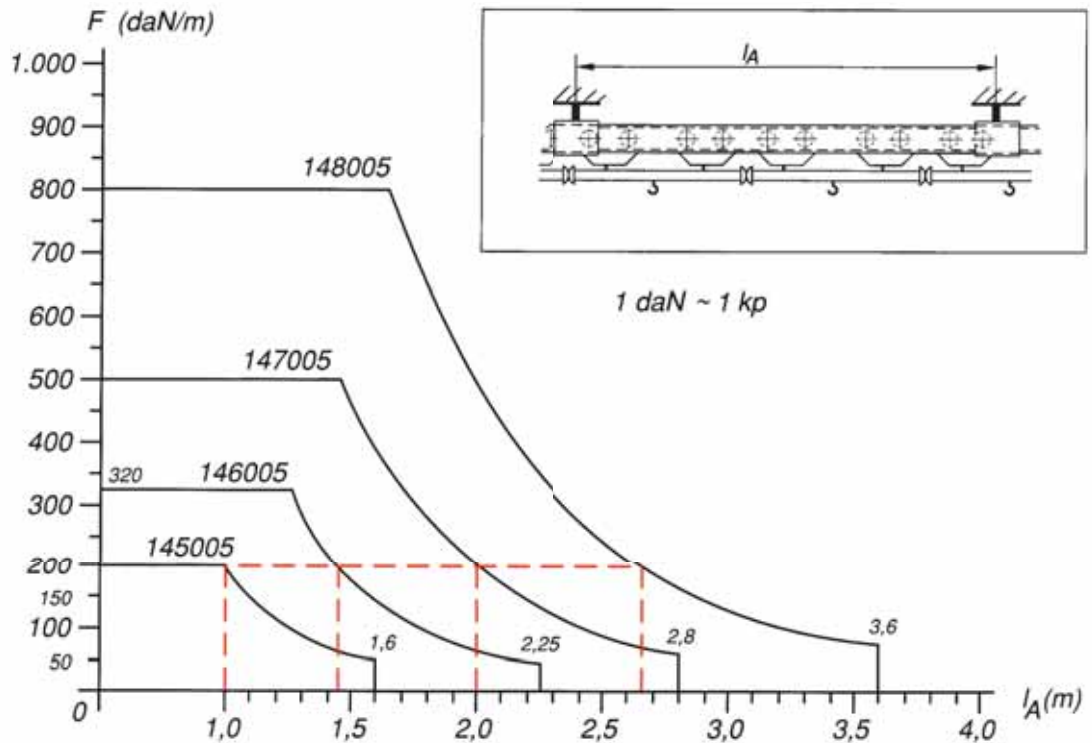

Example:

Weight of the transported goods = 50 daN
 Weight of the transport suspension unit = approx. 10 daN (including suspension gear)
 Total load = 60 daN

Transport units with cross bar $l = 300 \text{ mm}$ are to be used.

$$\text{The distributed load } F = \frac{\text{Total load (daN)}}{l \text{ (m)}} = \frac{60 \text{ (daN)}}{0,3 \text{ (m)}} = 200 \text{ daN/m.}$$

According to the diagram the support spacings are l_A : 1.0 m for C-rail 145005 or 1.45 m for C-rail 146005 or 2.0 m for C-rail 147005 and 2.66 m for C-rail 148005.

Suspension track - design example

Track layout

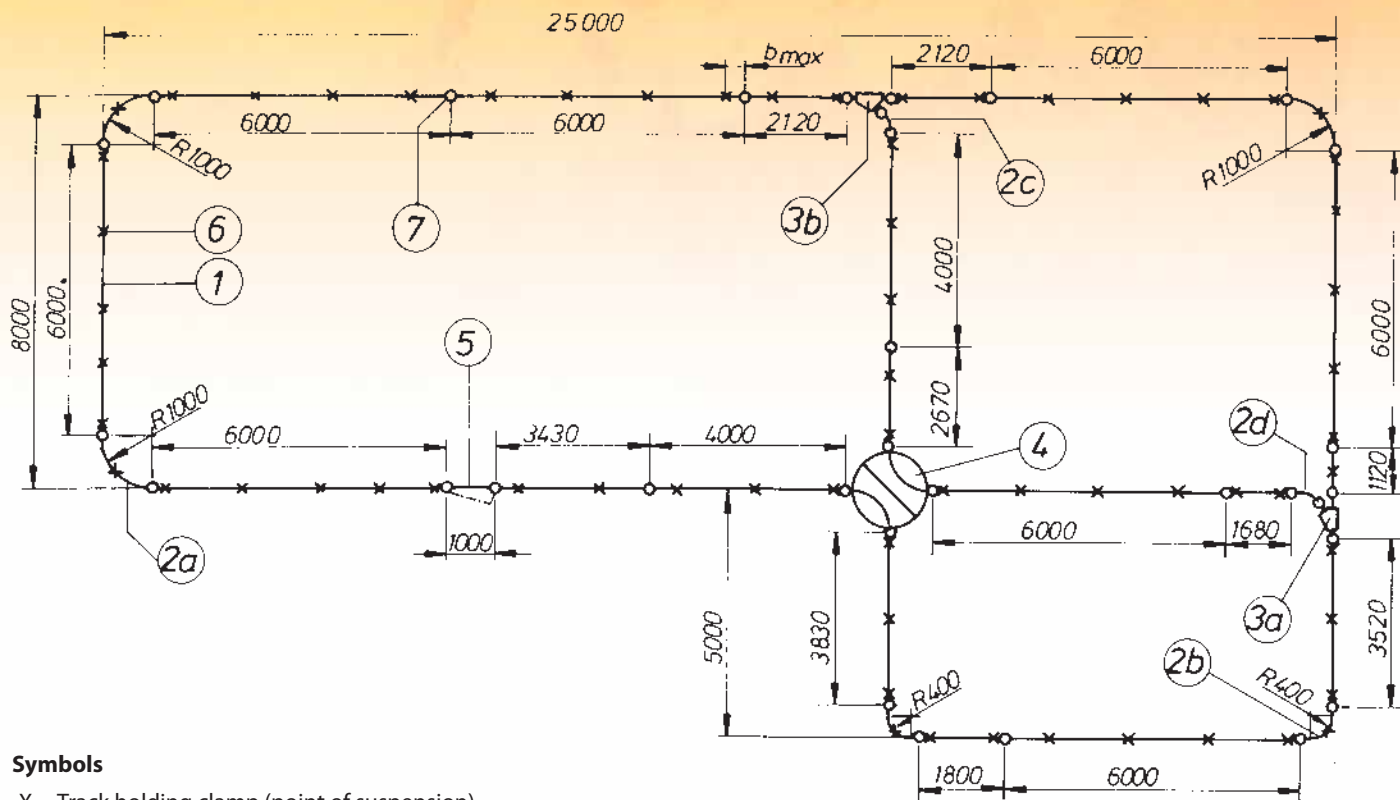

Symbols

- X Track holding clamp (point of suspension).
- Track connector (no point of suspension).

b_{max} = 200 with full utilization of the ultimate load.

Design example:

Given – Distributed load 50 daN/m according to the diagram on page H38 results in: Required support spacing l_A = 1.6 m; selected rail profile 145005.

Parts list

Position	qty/m	Description	Ident. No.	Order No.	Remark
1a	8	C-rail (6 m length)	0020613	NO 145005-6	We recommend ordering 6-m and 4-m sections and cutting the lengths during assembly.
1b	2	C-rail (4 m length)	0020611	NO 145005-4	
1c	24	C-rail (1 x 3.83 m, 1 x 3.43 m, 1 x 3.52 m, 1 x 2.67 m, 2 x 2.12 m, 1 x 1.8 m, 1 x 1.68 m, 1 x 1.12 m)	0019860	NO 145005	
2a	3	90° elbow (R = 1000 mm)	0019912	NO 145405-1000	
2b	2	90° elbow (R = 400 mm)	0019916	NO 145405-0400	
2c	1	45° elbow (R = 400 mm)	0019916	NO 145405-0400	Divide a 90° elbow at the installation site.
2d	1	45° elbow (R = 400 mm)	0019916	NO 145405-0400	
3a	1	Point switches	0019893	NO 145311-L 45°	
3b	1	Fall switch	0019901	NO 145315-R03 45°	With operating unit.
4	1	Turntable	0019909	NO 145362-01	
5	1	Pivoting piece (insert station)			L = 1000mm
6	64	Track holding clamp	0019917	NO 145511	Selection
7	30	Track connector	0019920	NO 145605	see page H 41 – H 44.

C-rails/Elbows/Connectors

C-rail

Materials:
Steel, galvanized



Technical data	Order No.				
	NO 145005	NO 146005	NO 147005	NO 148005	
Dimensions (mm)	a	40	50	63	80
	h	40	50	63	80
	s	2.5	3.2	4	5
Static values	Jx (cm ⁴)	7	17.8	44.2	117.6
	Wx (cm ³)	3.16	6.4	12.9	27.4
	Wgt. (kg/m)	2.55	4.1	6.53	10.52
Load-carrying capacity (daN/m)	200	320	500	800	

90° elbow

Materials: Steel, galvanized

Top view

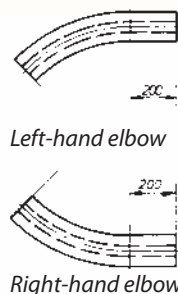

When ordering elbow segments, please include a sketch indicating whether you want a left-hand or a right-hand version. We recommend separating the segments from a 90° elbow on-site.

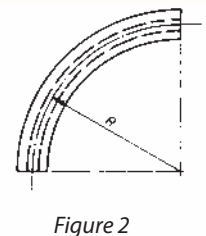
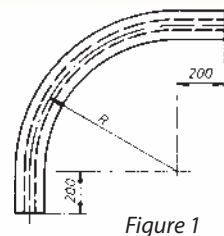
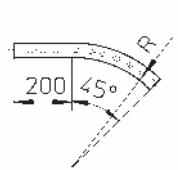

Figure 1

Figure 2

Other radii are available on request.

Elbow 45°



Left-hand design

(straight piece on the left)

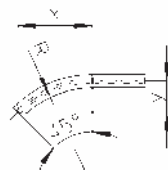

Right-hand design

(straight piece on the right)

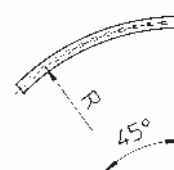

Elbow without straight piece

Fig. 1 (up to R = 1000 mm)

Fig. 2 (R = 1000 mm and higher)

Project dimensions
 $x = R \cdot 0,707$
 $y = R \cdot 0,293$

90° elbow, galvanized

Figure-No.	Radius (mm)	Order No.			
1	400	NO 145405-0400	NO 146405-0400	-	-
	600	NO 145405-0600	NO 146405-0600	NO 147405-0600	-
	800	NO 145405-0800	NO 146405-0800	-	-
	1000	NO 145405-1000	NO 146405-1000	NO 147405-1000	NO 148405-1000
2	1200	NO 145405-1200	NO 146405-1200	NO 147405-1200	NO 148405-1200
	1400	NO 145405-1400	NO 146405-1400	NO 147405-1400	NO 148405-1400
	1600	NO 145405-1600	NO 146405-1600	NO 147405-1600	NO 148405-1600
	2000	NO 145405-2000	NO 146405-2000	NO 147405-2000	NO 148405-2000

Elbow 45° galvanized

1	Right	400	NO 145415-0400R	NO 146415-0400R	NO 147415-0400R	NO 148415-0400R
		600	NO 145415-0600R	NO 146415-0600R	NO 147415-0600R	NO 148415-0600R
		800	NO 145415-0800R	NO 146415-0800R	NO 147415-0800R	NO 148415-0800R
	Left	400	NO 145415-0400L	NO 146415-0400L	NO 147415-0400L	NO 148415-0400L
		600	NO 145415-0600L	NO 146415-0600L	NO 147415-0600L	NO 148415-0600L
		800	NO 145415-0800L	NO 146415-0800L	NO 147415-0800L	NO 148415-0800L
2	1000	NO 145415-1000	NO 146415-1000	NO 147415-1000	NO 148415-1000	
	1200	NO 145415-1200	NO 146415-1200	NO 147415-1200	NO 148415-1200	
	1400	NO 145415-1400	NO 146415-1400	NO 147415-1400	NO 148415-1400	
	1600	NO 145415-1600	NO 146415-1600	NO 147415-1600	NO 148415-1600	
	2000	NO 145415-2000	NO 146415-2000	NO 147415-2000	NO 148415-2000	

Track holding clamp/connector

C-rail	NO 145005	NO 146005	NO 147005	NO 148005
--------	-----------	-----------	-----------	-----------

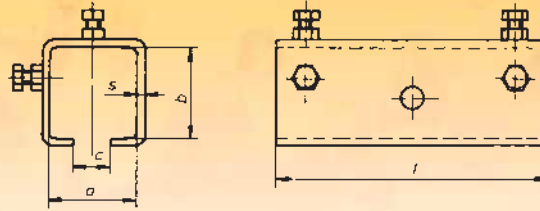

Technical data		Ident. No.	Order No.	Ident. No.	Order No.	Ident. No.	Order No.	Ident. No.	Order No.
Design	Galvanized	0019920	NO 145605	0019976	NO 146605	0020175	NO 147605	0020078	NO 148605
	Bare	0020643	NO 24140	0020776	NO 25140	0020794	NO 25640	0020812	NO 26140
Dimensions (mm)	a	41.3		51.7		65.5		83	
	b	41		51.2		64.2		83	
	c	18.4		24.6		26		34	
	l	125		160		200		250	
	s	4		4		5		6	
Weight (kg)		0.6		1		1.9		3.6	

Track holding clamp for welding

Materials:
Steel, bare.

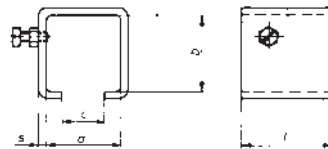

Technical data		Ident. No.	Order No.	Ident. No.	Order No.	Ident. No.	Order No.	Ident. No.	Order No.
		0020632	NO 24120	0020771	NO 25120	0020790	NO 25620	0020808	NO 26120
Dimensions (mm)	a	40.5		51.7		64.7		81.7	
	b	40.5		51.7		64.7		81.7	
	c	17		25		25		31	
	l	50		80		100		120	
	s	4		4		5		6	
Load-carrying capacity (daN)		200		250		320		400	
Weight (kg)		0.22		0.5		0.94		1.75	

Track holding clamp

Materials:
Steel, galvanized

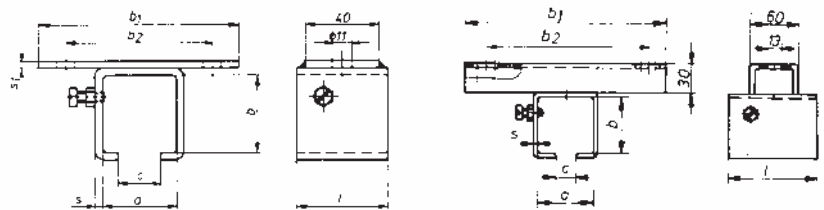

Version for NO 145511 and NO 146511

Version for NO 147511 and NO 148511

Technical data		Ident. No.	Order No.	Ident. No.	Order No.	Ident. No.	Order No.	Ident. No.	Order No.
		0019917	NO 145511	0019974	NO 146511	0020173	NO 147511	0020076	NO 148511
Dimensions (mm)	a	40.5		51.7		64.7		81.7	
	b	40.5		51.7		64.7		81.7	
	b ₁	110		130		175		175	
	b ₂	80		100		130 +/- 20		130 +/- 20	
	c	17		25		25		31	
	l	50		80		100		120	
	s	4		4		5		6	
	s ₁	6		8		-		-	
Load-carrying capacity (daN)		250		400		630		1000	
Weight (kg)		0.36		0.8		0.65		2.4	

Leaving technical changes!

Track holding clamp/connector

C-rail	NO 145005	NO 146005	NO 147005	NO 148005
--------	-----------	-----------	-----------	-----------

Track connector

Materials: Steel.
Design: Galvanized.

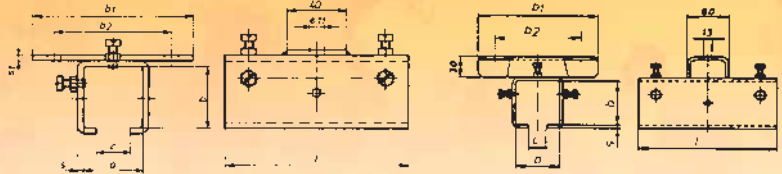

Version for NO 145611 and NO 146611

Version for NO 147611 and NO 148611

Technical data		Ident. No.	Order No.	Ident. No.	Order No.	Ident. No.	Order No.	Ident. No.	Order No.
		0019921	NO 145611	0019977	NO 146611	0020176	NO 147611	0020079	NO 148611
Dimensions (mm)	a	40.5		51.7		64.7		81.7	
	b	40.5		51.7		64.7		81.7	
	b ₁	110		130		175		175	
	b ₂	80		100		130 +/- 20		130 +/- 20	
	c	17		25		25		31	
	l	125		160		200		250	
	s	4		4		5		6	
	s ₁	6		8		-		-	
Load-carrying capacity (daN)		250		400		630		1000	
Weight (kg)		0.66		1.3		2.65		4.15	

Track holding clamp and track connector

Materials: Steel, galvanized

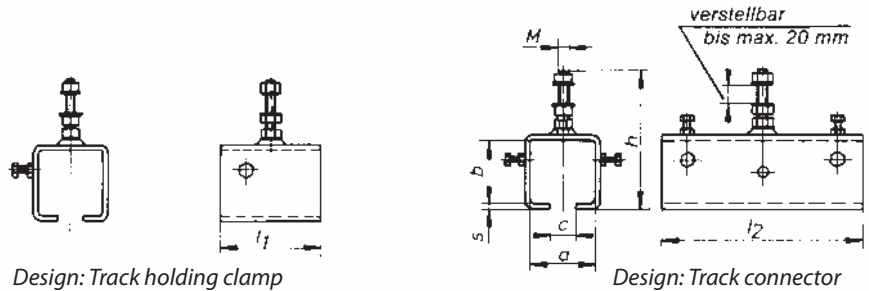

Design: Track holding clamp

Design: Track connector

Technical data		Ident. No.	Order No.	Ident. No.	Order No.	Ident. No.	Order No.	Ident. No.	Order No.
Design	Track holding clamp	0019918	NO 145525	0019975	NO 146525	0020174	NO 147525	0020077	NO 148525
	Track connector	0019922	NO 145625	0019978	NO 146625	0020177	NO 147625	0020080	NO 148625
Dimensions (mm)	a	40.5		51.7		64.7		81.7	
	b	40.5		51.7		64.7		81.7	
	c	17		25		25		31	
	h	110		125		140		170	
	l ₁	50		80		100		120	
	l ₂	125		160		200		250	
	M	M8/M12		M12		M12		M16	
	s	4		4		5		6	
Load-carrying capacity (daN)		200		320		400		500	
Weight (kg)	Track holding clamp	0.32		0.52		0.97		1.8	
	Track connector	0.61		1.02		1.93		3.7	

Track holding clamp and track connector

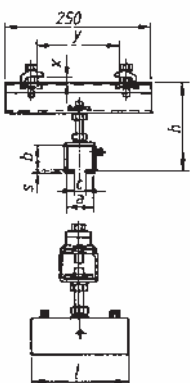

Design		Ident. No.	Order No.	Ident. No.	Order No.	Ident. No.	Order No.	Ident. No.	Order No.
Design	Track holding clamp	0027560	NO 145541	0027561	NO 146541	0027562	NO 147541	0027563	NO 148541
	Track connector	0027564	NO 145641	0027565	NO 146641	0027566	NO 147641	0027567	NO 148641
Dimensions (mm)	a	40.5		51.7		64.7		81.7	
	b	40.5		51.7		64.7		81.7	
	c	17		25		25		31	
	h	127 - 152		138 - 163		-		-	
	l (tr. clamp)	50		80		100		120	
	l (tr. connector)	125		160		200		250	
	s	4		4		5		6	
	x	Clamping height		6 - 11		-		-	
	y	Clamping width		42 - 130		-		-	
Load-carrying capacity (daN)		200		320		-		-	

Track holding clamps/connectors/stops

C-rail

NO 145005

NO 146005

NO 147005

NO 148005

Track holding clamp and track connector

Materials: Steel, galvanized

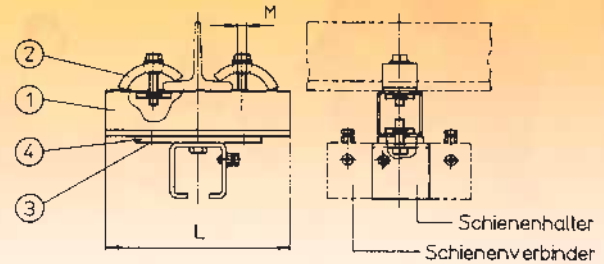
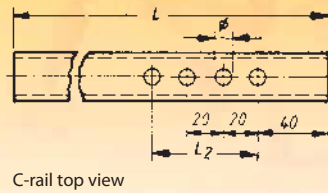

① Clamping arm

Materials: Steel, galvanized.

Dimensions (mm)

L	L2	Ident. No.	Order No.	Ident. No.	Order No.	Ident. No.	Order No.	Ident. No.	Order No.
250	200	0020381	NO 20186-0250	0020406	NO 20278-0250	0020402	NO 20274-0250	0020402	NO 020274-0250
315	260	0020382	NO 20186-0315	0020407	NO 20278-0315	0020403	NO 20274-0315	0020403	NO 020274-0315
400	340	0020383	NO 20186-0400	0020408	NO 20278-0400	0020404	NO 20274-0400	0020404	NO 020274-0400
500	340	0020384	NO 20186-0500	0020409	NO 20278-0500	0020405	NO 20274-0500	0020405	NO 020274-0500
Hole Ø		9		11		11		11	

④ Track holding clamp and track connector

Materials: Steel, galvanized (for dimensions and data, see page H 00.)

Design	Ident. No.	Order No.	Ident. No.	Order No.	Ident. No.	Order No.	Ident. No.	Order No.
Track holding clamp	0019917	NO 145511	0019974	NO 146511	0020173	NO 147511	0020076	NO 148511
Track connector	0019921	NO 145611	0019977	NO 146611	0020176	NO 147611	0020079	NO 148611

② Clamping jaw

Materials: Steel, galvanized.

Design	Ident. No.	Order No.	Ident. No.	Order No.	Ident. No.	Order No.	Ident. No.	Order No.
Bolt M	0020822	NO 40127-08	0020823	NO 40127-10	0020823	NO 40127-10	0020824	NO 40127-12
		M8 x 50		M10 x 50		M10 x 50		M12 x 60

③ Bolt set

With square nut for C-rail. Materials: Steel, galvanized.

Design	Ident. No.	Order No.	Ident. No.	Order No.	Ident. No.	Order No.	Ident. No.	Order No.
Bolt M	0020819	NO 40125-08x15	0020820	NO 40125-10x12	0020820	NO 40125-10x12	0020820	NO 40125-10x12
		M8 x 25		M10 x 25		M10 x 25		M12 x 25
Max. clamp length		14.5		12		12		12

End stop

Assembly instructions: End stops must be secured at right angles to the rails via locking screws.

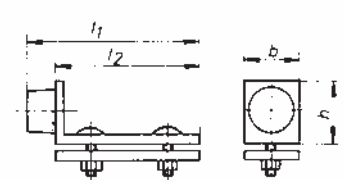
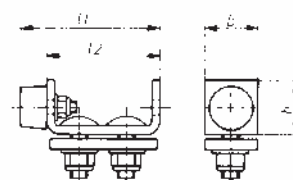
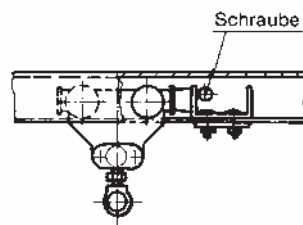

Version for NO 24111 and NO 25115

Version for NO 25617 and NO 26117

Technical data	Ident. No.	Order No.	Ident. No.	Order No.	Ident. No.	Order No.	Ident. No.	Order No.
	0020630	NO 24111	0020770	NO 25115	0020789	NO 25617	0020807	NO 26117
Dimensions (mm)	b	30		30		45		60
	h	30		30		50		60
	l1	69		69		100		120
	l2	53		53		80		100
Weight (kg)		0.19		0.19		0.8		0.95
Locking screw	0028346	NO 40150-08x50	0028347	NO 40150-10x65	0020825	NO 40150-12x75	0028348	NO 40150-12x100
Dimensions		M8 x 50		M10 x 65		M12 x 75		M12 x 100
Weight (kg)		0.19		0.19		0.8		0.95

Switches

C-rail

NO 145005

NO 146005

NO 147005

NO 148005

Switches

TORWEGGE standard turnouts can be used as both **point switches** and **fall switches**.
When used as a fall switch, only one operating unit with a chain is provided.
Design: Surface galvanized.

Point switches

Switched from the chassis; automatically reset to home position via spring; passage only in one direction.

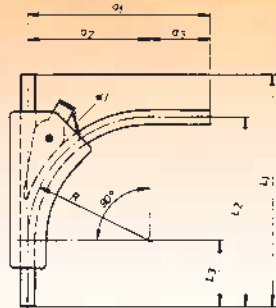

Point switches 90°, Right-hand design.

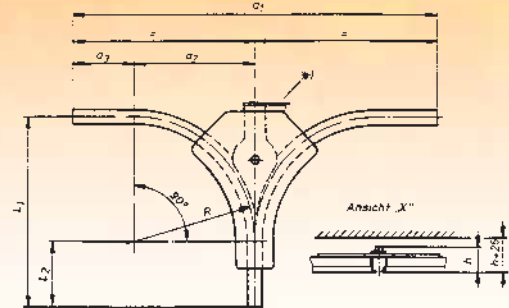

Point switches 90°, Right-/left-hand design.

Fall switches

Can be set manually via the chain or linkage and remains in the adjusted position; Passage possible in all directions

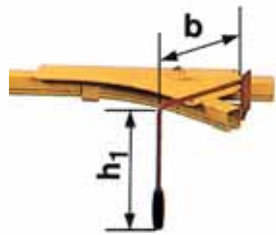

Fall switch with shift linkage 45° + 90°
Design: -02, available on request.

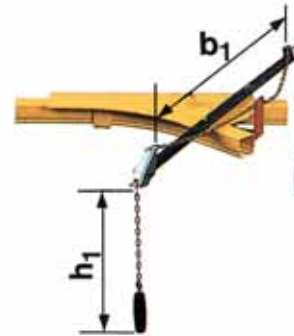

Fall switch 45° + 90° with operating unit (chain hoist).
Design: -03

Design		Ident. No.	Order No.	Ident. No.	Order No.	Ident. No.	Order No.	Ident. No.	Order No.
Point switches 45°	Right	0019894	NO 145311-R45°	0019950	NO 146311-R45°	0020041	NO 147311-R45°	0020204	NO 148311-R45°
	Left	0019893	NO 145311-L45°	0019949	NO 146311-L45°	0020040	NO 147311-L45°	0020203	NO 148311-L45°
	Right-hand/left-hand	0019895	NO 145311-RL45°	0019951	NO 146311-RL45°	0020042	NO 147311-RL45°	0020205	NO 148311-RL45°
Point switches 90°	Right	0019897	NO 145313-R90°	0019953	NO 146313-R90°	0020044	NO 147313-R90°	0020207	NO 148313-R90°
	Left	0019896	NO 145313-L90°	0019952	NO 146313-L90°	0020043	NO 147313-L90°	0020206	NO 148313-L90°
	Right-hand/left-hand	0028699	NO 145313-RL90°	0019954	NO 146313-RL90°	0020045	NO 147313-RL90°	0020208	NO 148313-RL90°
with chain									
Fall switch 45°	Right	0019901	NO 145315-R03 45°	0019958	NO 146315-R03 45°	0020058	NO 147315-R03 45°	0020212	NO 148315-R03 45°
	Left	0019899	NO 145315-L03 45°	0019956	NO 146315-L03 45°	0020047	NO 147315-L03 45°	0020210	NO 148315-L03 45°
	Right-hand/left-hand	0019903	NO 145315-RL03 45°	0019960	NO 146315-RL03 45°	0020060	NO 147315-RL03 45°	0020214	NO 148315-RL03 45°
Fall switch 90°	Right	0019905	NO 145317-R03 90°	0019962	NO 146317-R03 90°	0020062	NO 147317-R03 90°	0020216	NO 148317-R03 90°
	Left	0019904	NO 145317-L03 90°	0019961	NO 146317-L03 90°	0020061	NO 147317-L03 90°	0020215	NO 148317-L03 90°
	Right-hand/left-hand	0019907	NO 145317-RL03 90°	0019963	NO 146317-RL03 90°	0020063	NO 147317-RL03 90°	0020217	NO 148317-RL03 90°

Ordering example: A left-hand fall switch construction is required with chain hoist operation.
Order No.: Fall switch NO 145315-L03.

Dimensions		mm	mm	mm	mm
Project dimensions	a1	1200	1200	1600	1600
	a2	400	400	600	600
	a3	200	200	200	200
	h	70	81	100	116
	L1	615	650	905	955
	L2	215	250	305	355
	R	400	400	600	600

Pneumatic actuation on request.

Product similar to illustrations!

www.torwegge-group.com

Switches

C-rail	NO 145005	NO 146005	NO 147005	NO 148005
--------	-----------	-----------	-----------	-----------

Turntables

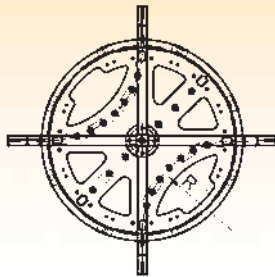
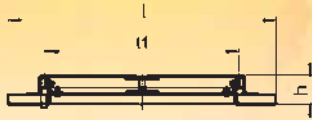

Version for 40 x 40 and 50 x 50.
Materials: Steel, galvanized.

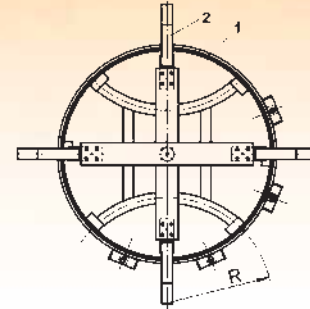
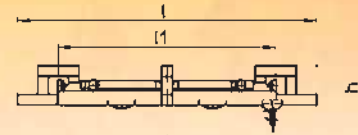

Version for 63 x 63 and 80 x 80.
Materials: Painted steel, standard silver.

The turnouts are connected to the C-rails via four track connectors. The track connectors necessary for this are to be ordered separately.

Design	Ident. No.	Order No.	Ident. No.	Order No.	Ident. No.	Order No.	Ident. No.	Order No.
With eyelet	0019908	NO 145361-01	0019964	NO 146361-01	0020064	NO 147361-01	0020218	NO 148361-01
With eyelet	0019909	NO 145362-01	0019965	NO 146362-01	0020065	NO 147362-01	0020219	NO 148362-01
Dimensions (mm)	a	1150		1200		1700		2550
	D	800		800		1230		2030
	h	123		133		226		243
	R	400		400		600		1000

Other switches and turntables are available, e.g., pneumatic rotating switches.
You can also request our technical consulting services.



Suspension track system on a beach chair production line.
Delivery to painting plant.
Use of rotating and fall switches.

Leaving technical changes!

Accessories/stops

A number of stops and locking devices may be necessary, depending on requirements and track layout. These are mechanically actuated and can also be operated pneumatically if required.

Simple stop ...911



Stops are used if the conveyed product is to be blocked in buffer sections, held in front of discharge sections or positioned at workstations.

Stop with individual release ...921



Only suitable for cross beam trolleys measuring 400 mm and 500 mm in length.

Return stop ...913



Prevents a transport suspension unit from running back.

Locking device 1

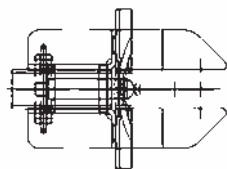

Individual orders of items ① and ② for deviating installation requirements, e.g. if several branch lines are to be connected to an equipment crane.

Stop piece 2

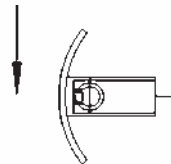

In locked condition

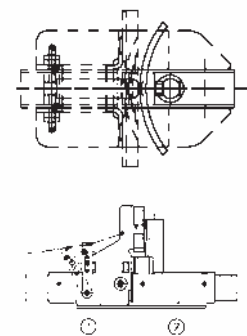

Pos.	For C-rail	Order No.
① Locking device	NO 145005	NO 145963
	NO 146005	NO 146963
	NO 147005	NO 147963
	NO 148005	NO 148963
② Stop piece	NO 145005	NO 145964
	NO 146005	NO 146964
	NO 147005	NO 147964
	NO 148005	NO 148964

Accessories/stops

Design	Ident. No.	Order No.	Ident. No.	Order No.	Ident. No.	Order No.	Ident. No.	Order No.
C-rails		NO 145005		NO 146005		NO 147005		NO 148005
Simple stop	0019924	NO 145911	0019979	NO 146911	0020178	NO 147911	0020081	NO 148911
Stop with individual release	0019925	NO 145921	0019981	NO 146921	0020180	NO 147921	0020083	NO 148921
Return stop	0019926	NO 145913	0019980	NO 146913	0020179	NO 147913	0020082	NO 148913
Locking device ①	0019927	NO 145963	0019982	NO 146963	0020181	NO 147963	0020084	NO 148963
Stop piece ②	0019928	NO 145964	0028700	NO 146964	0020182	NO 147964	0020085	NO 148964

Transport unit

C-rail

NO 145005

NO 146005

NO 147005

NO 148005

Transport unit

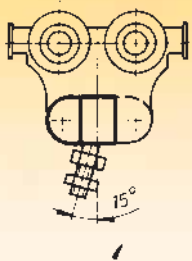

Versions with pivoting and oscillating ball pins are used as standard transport units (see figure).

Working temperature: -30°C to $+60^{\circ}\text{C}$.

High-temperature transport units and rollers are available for use at higher temperatures (versions up to 300°C).

For the suspension of electrical devices, e.g., spot welding guns, the trolleys can be supplied in an **insulated version** for isolation of ground currents.

2-roller transport unit

Materials: Steel, galvanized

The transport units for C-rail 145005 are available with ball pin threads M12 or M16.

Ordering example: M12 requested

Order number: NO 145010-12B

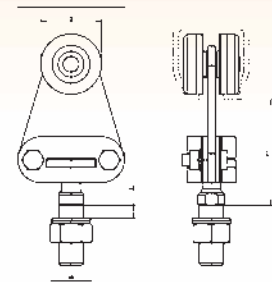

Technical data		Ident. No.	Order No.	Ident. No.	Order No.	Ident. No.	Order No.	Ident. No.	Order No.
Design	Standard design	0019862	NO 145010-B	0019931	NO 146010-B	0020001	NO 147010-B	0020185	NO 148010-B
	Insulated design	-	-	-	-	0020012	NO 147050-B	0020195	NO 148050-B
	Versions up to 300°C	0019883	NO 145110-B	0019947	NO 146110-B	0020038	NO 147110-B	0020201	NO 148110-B
Dimensions (mm)	d		32		40		52		62
	h_1		75		70		85		80
	l		70		70		70		70
	M		M12 or M16		M16		M16		M16
	s_{max}		26		26		26		26
Load-carrying capacity (daN)			50		80		100		125
Weight (kg)			0.5		0.60		0.75		0.85

4-roller transport unit

Materials: Steel, galvanized

The transport units for C-rail 145005 are available with ball pin threads M12 or M16.

Ordering example: M12 requested

Order number: NO 145020-12B

For bends of radius 400 mm and above.

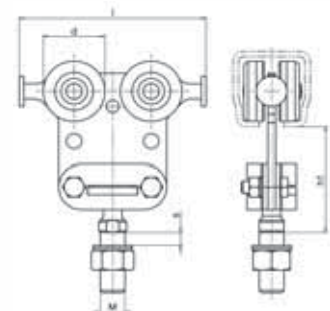

Technical data		Ident. No.	Order No.	Ident. No.	Order No.	Ident. No.	Order No.	Ident. No.	Order No.
Design	Standard design	0019871	NO 145020-B	0019936	NO 146020-B	0020005	NO 147020-B	0020189	NO 148020-B
	Insulated design	-	-	-	-	0020014	NO 147060-B	0020197	NO 148060-B
	Versions up to 300°C	0019885	NO 145120-B	0019948	NO 146120-B	0020039	NO 147120-B	0020202	NO 148120-B
Dimensions (mm)	d		32		40		52		62
	h_1		75		70		85		80
	l		120		120		160		160
	M		M12 or M16		M16		M16		M16
	s_{max}		26		26		26		26
Load-carrying capacity (daN)			100		160		200		250
Weight (kg)			0.75		0.85		1		1.2

Transport unit

C-rail	NO 145005	NO 146005	NO 147005	NO 148005
--------	-----------	-----------	-----------	-----------

Transport unit with ring nut and 2 rollers

Materials: Steel, galvanized

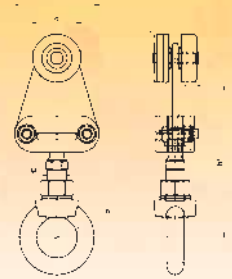

Technical data		Ident. No.	Order No.	Ident. No.	Order No.	Ident. No.	Order No.	Ident. No.	Order No.
Design	Standard design	0019864	NO 145011-12B	0019932	NO 146011-B	0020002	NO 147011-B	0020186	NO 148011-B
	Insulated design	-	-	-	-	0020013	NO 147051-B	0020196	NO 148051-B
Dimensions (mm)	d	32	40	52	62				
	h ₁	130	125	140	135				
	l	70	70	70	70				
	M	M12	M16	M16	M16				
	Øo	30	35	35	35				
Load-carrying capacity (daN)		50	80	100	125				
Weight (kg)		0.6	0.7	0.85	0.95				

Transport unit with ring nut and 4 rollers

Materials: Steel, galvanized
For bends starting at 400 mm.

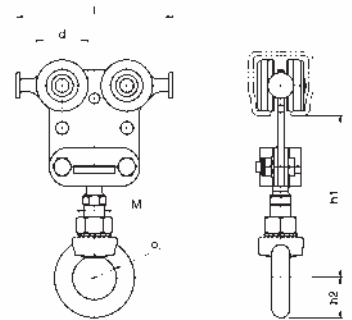

Technical data		Ident. No.	Order No.	Ident. No.	Order No.	Ident. No.	Order No.	Ident. No.	Order No.
Design	Standard design	0019873	NO 145021-12B	0019939	NO 146021-B	0020006	NO 147021-B	0020190	NO 148021-B
	Insulated design	-	-	-	-	0020015	NO 147061-B	0020198	NO 148061-B
Dimensions (mm)	d	32	40	52	62				
	h ₁	130	125	140	135				
	h ₂	32	32	32	32				
	l	120	100	160	160				
	M	M12	M16	M16	M16				
	Øo	30	35	35	35				
Load-carrying capacity (daN)		100	160	200	250				
Weight (kg)		0.85	0.95	1.1	1.3				

Transport unit to be welded with 2 rollers

Materials:
Casters: Steel, galvanized.
Plate: Steel, bare.

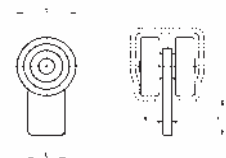

Technical data		Ident. No.	Order No.	Ident. No.	Order No.	Ident. No.	Order No.	Ident. No.	Order No.
Dimensions (mm)	a	25	25	40	40				
	d	32	40	52	62				
	h	29	24	32	26				
	s	5	6	8	8				
Load-carrying capacity (daN)		50	80	100	125				
Weight (kg)		0.15	0.25	0.32	0.42				

Transport unit

C-rail	NO 145005	NO 146005	NO 147005	NO 148005
--------	-----------	-----------	-----------	-----------

Transport unit to be welded with 4 rollers

Materials:
 Casters: Steel, galvanized.
 Plate: Steel, bare.

Not for bends of radius below 800 mm.

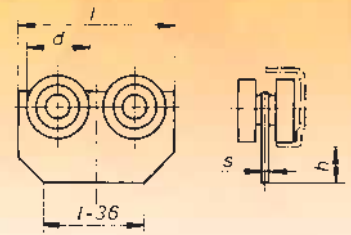

Technical data		Ident. No.	Order No.	Ident. No.	Order No.	Ident. No.	Order No.	Ident. No.	Order No.
		0019880	NO 145092	0019945	NO 146092	0020036	NO 147092	0020199	NO 148092
Dimensions (mm)	d	32		40		52		62	
	h	50		45		51		45	
	l	120		120		160		160	
	s	5		5		8		8	
Load-carrying capacity (daN)		100		160		200		250	
Weight (kg)		0,45		0,55		0,7		0,9	

Transport unit for load hooks with 4 rollers

Materials:
 Casters: Steel, galvanized.
 Load-carrying part: galvanized.

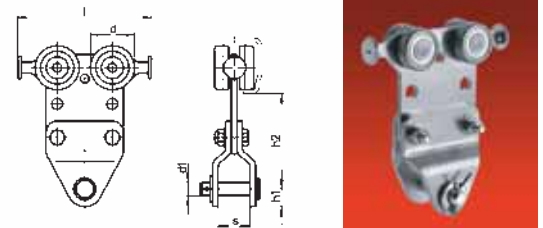

Technical data		Ident. No.	Order No.	Ident. No.	Order No.	Ident. No.	Order No.	Ident. No.	Order No.
		0019875	NO 145024	0019940	NO 146024	0020009	NO 147024	0020192	NO 148024
Dimensions (mm)	s	29		29		40		40	
	h ₁	16		16		22		22	
	h ₂	92		87		107		101	
	d ₁	32		40		52		62	
	d ₂	12		12		20		20	
Load-carrying capacity (daN)		100		160		250		400	
Weight (kg)		0,75		0,85		1		1,2	

Flat cable trolley and end clamp

Materials:
 Casters: Steel, galvanized.
 Load-carrying part: Steel, galvanized.
 Bearing surface: Plastic.
 Buffer: Rubber.
 Small parts: Steel, galvanized.

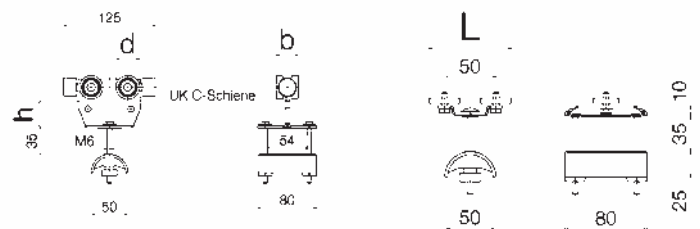

Cable trolleys

End clamp

Technical data		Ident. No.	Order No.	Ident. No.	Order No.	Ident. No.	Order No.	Ident. No.	Order No.
Design	Cable trolleys	0020682	NO 24242-125	0028957	NO 25270-125x80	0028958	NO 25770-125x80	0028959	NO 26270-125x80
	End clamp	0020521	NO 23269	0028960	NO 25290	0028961	NO 25790	0028962	NO 26290
Dimensions (mm)	d	30		37		47		62	
	b	32		25		32		32	
	h	40		42		38		38	
	l	75		80		80		80	
Weight (kg)	Cable trolleys	0,54		0,52		0,54		0,54	
	End clamp	0,19		0,18		0,19		0,19	

Transport unit

C-rail	NO 145005	NO 146005	NO 147005	NO 148005
--------	-----------	-----------	-----------	-----------

Round cable trolley and end clamp



Materials:
Casters: Steel, galvanized.
Load-carrying part: Steel, galvanized.
Bearing surface: Plastic.
Buffer: Rubber.
Small parts: Steel, galvanized.

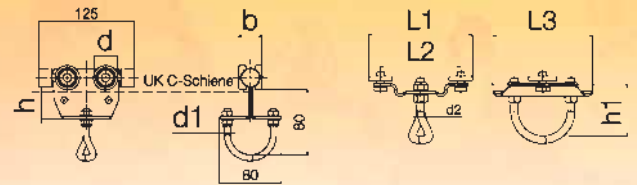

Technical data		Ident. No.	Order No.	Ident. No.	Order No.	Ident. No.	Order No.	Ident. No.	Order No.
Design	Cable trolley	0020705	NO 24316-125	0020780	NO 25396-125	0020799	NO 25896-125	0028953	NO 26396-125
	End clamp	0020708	NO 24318	0028954	NO 25398	0028955	NO 25898	0028956	NO 26398
Dimensions (mm)	d	30		37		47		32	
	b	32		25		32		32	
	d ₁	8		6		8		8	
	d ₂	8		6		8		8	
	h	38		42		38		38	
	h ₁	55		62		60		60	
	l ₁	110		80		110		110	
	l ₂	85		50		85		85	
Weight (kg)	Cable trolley	0,57		0,55		0,57		0,57	
	End clamp	0,32		0,4		0,7		0,7	

Transport unit WITH and WITHOUT snap-in locking device

Materials: Steel, galvanized

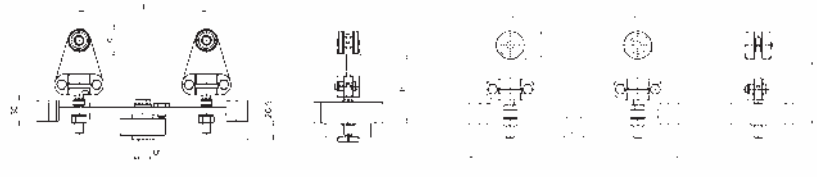

Technical data		Ident. No.	Order No.*	Ident. No.	Order No.*	Ident. No.	Order No.*	Ident. No.	Order No.*
Design	Without snap-in locking device	0019867	NO 145015-B	0019933	NO 146015-B	-		-	
	With snap-in locking device	0019870	NO 145018-..B	0019934	NO 146018-..B	-		-	
Dimensions (mm)	d	32		40		-		-	
	h	95		90		-		-	
	l	300		300		-		-	
	l ₁	180		180		-		-	
M		M12/M14		M12/M14		-		-	
Load-carrying capacity (daN)			100		125		-		-
Weight (kg)			2,7		2,8		-		-

* Please specify thread size M!

Transport unit WITH and WITHOUT snap-in locking device

Materials: Steel, galvanized

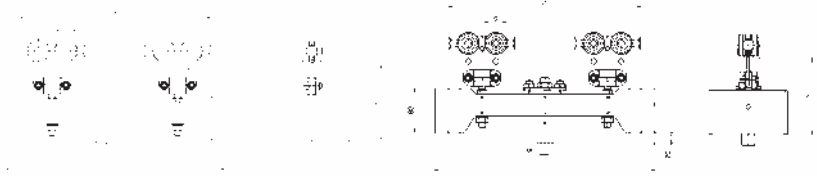

Technical data		Ident. No.	Order No.*	Ident. No.	Order No.*	Ident. No.	Order No.	Ident. No.	Order No.
Design	Without snap-in locking device	0019876	NO 145025-400	0019942	NO 146025-400	0020010	NO 147025-400	0020193	NO 148025-400
	With snap-in locking device	0019878	NO 145028-400	0019943	NO 146028-400	0020011	NO 147028-400	0020194	NO 148028-400
5Dimensions (mm)	d	32		40		52		62	
	h	95		90		155		149	
	l	300		300		400		400	
	l ₁	300		300		388		388	
M		M12/M14		M12/M14		M16		M16	
Load-carrying capacity (daN)			200		250		400		500
Weight (kg)			3,2		3,3		-		-

* Please specify thread size M!

Transport unit

C-rail	NO 145005	NO 146005	NO 147005	NO 148005
--------	-----------	-----------	-----------	-----------

Transport unit with eyelet and 4 rollers



Materials:
Casters: Steel, galvanized.
Load-carrying part: galvanized.

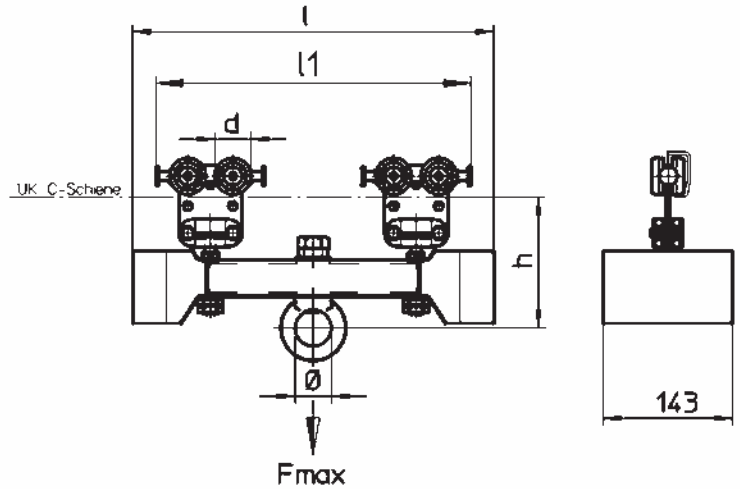

Technical data	Ident. No.	Order No.	Ident. No.	Order No.	Ident. No.	Order No.	Ident. No.	Order No.
l = 400	0028993	NO 145026-400	0028994	NO 146026-400	0028995	NO 147026-400	0028996	NO 148026-400
l = 500	0028997	NO 145026-500	0028998	NO 146026-500	0028999	NO 147026-500	0029000	NO 148026-500
l = 630	0029001	NO 145026-630	0029002	NO 146026-630	0029003	NO 147026-630	0029004	NO 148026-630
Project dimensions (mm)								
l ₁		I-52		I-52		I-52		I-52
Ø d		32		40		52		62
h		150		145		160		154
Ø		40		40		40		40
Max. load on cross bars								
Cross bar lengths (mm)								
l = 400		200		320		400		500
l = 500		200		320		400		500
l = 630		200		320		400		500

Check the max. permissible distributed load of the C-rail.

Fittings for hanging sliding gates (for rails, see page H 41)

Materials:

Steel, galvanized.

NO 145005

NO 146005

NO 147005

NO 148005

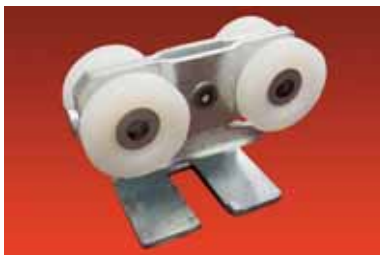
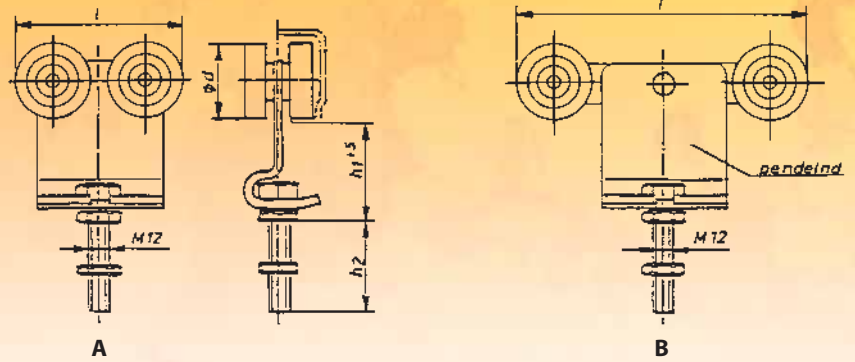

Order No.	For rail	Dimensions				M	Load-carrying capacity daN
		d mm	h ₁ mm	h ₂ mm	l mm		
Type A							
NO 43925	30	25	35	20	78	M12	50
NO 43935	40	32	56	20	82	M12	100
NO 43945	50	40	51	20	90	M12	125
Type B							
NO 43939	40	32	56	20	157	M12	50
NO 43949	50	40	51	20	170	M12	80
NO 43959	63	52	44	20	182	M12	100
Special running gear							
NO 43935-B	40	35	38	102	90	M12	50

Running gear

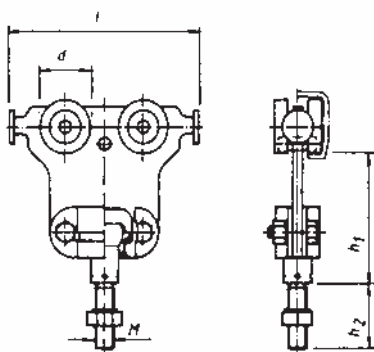

With rotating and swinging pin

NO 145020-12B	40	32	75	40	120	M12	100
NO 146020-B	50	40	70	40	120	M16	160
NO 147020-B	63	52	58	40	160	M16	200
NO 148020-B	80	62	80	40	160	M16	250

Lower guide rail

Order No. 1115/6

Sendz.-galv. 6 m length Length



Guide for screwing

Order No. 1059



Easy-Slide - Fitting set for cantilever gates

Rediscover the cantilever gate! Together we can make a formidable team! You build the gate* according to your requirements, and we will make it move. With or without power drive – simply

Easy-Slide



**Clear passage up to 4.5 m.
Maximum weight of gate body
250 kg.**

- Securely blocks off your driveway.
- Entry is not obstructed in any way when the gate is open.
- Passage is not obstructed by any tripping hazards.
- The smallest space requirement; the large space required for swing gates does not apply.
- Also functions in snow and with dirt in the driveway.
- Ideal for short driveways.
- Functions independently of the driveway surface.
- Can be used for both upward-sloping and downward-sloping driveways.
- Simple assembly, no supporting columns.

Simply choose your Easy-Slide system package. Whether it's with or without a drive, you will receive a complete package that you can erect in just a few minutes according to the modular system principle, without any need for welding.

Lengthy aligning and testing procedures are a thing of the past. Place the base plate of the Easy-Slide system on the prefabricated foundation, and start screwing down the individual components.

The base plate offers unlimited possibilities for designing the gate. The provided 6-m-long slide rail, which can be shortened to any desired length, allows the system to be individually adapted to suit any driveway width from 1000 mm up to 4500 mm

Screwing all of the gate's components together means that welding work and additional galvanizing or painting procedures can be dispensed with.

The gate column, which is also fastened with screws, serves as the carrier for the guide roller and can be retrofitted with flashing lights and other electronic components if required.

** The gate must be rigidly constructed according to the relevant rules for cantilever gates because the fitting doesn't carry the gate, but instead the gate carries the fitting.*

The power drive

The Lift Master 300 power drive provides you with a robust but precise and smoothly operating gate actuator. Of course, we supply the gate actuator with light barrier, gear rack, assembly material, and hand-held transmitter.



The roller units

They form the heart of the Easy-Slide system and are manufactured with the highest degree of precision and equipped with ball bearings in runner and guide rollers.



Our service for you:

We will calculate your cantilever gate.
Give us the dimensions and weight of your gate.
You will promptly be faxed your gate and foundation plan.

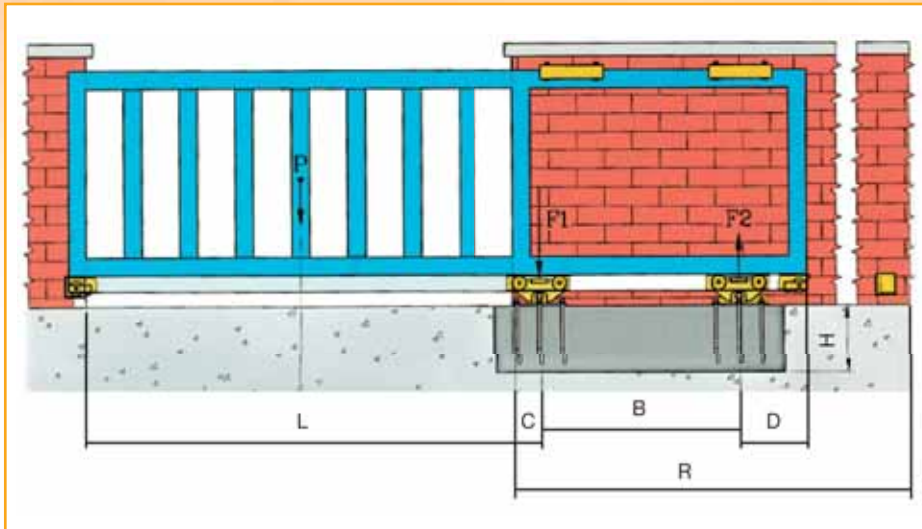

Openings per day

Wind permeability Yes No

Width of opening L (m)

Weight of door in the clearance opening without rail (kg)

Stowage space distance R (m)

Guide roller

For screwing

For embedding in concrete

Rail Bright Galvanized

We will provide you with the following information:

- Distance between roller units (B).
- Dimensions C and D.
- Overall rail length.
- Weight of gate with rail.
- Minimum weight of a foundation.
- Minimum dimensions of a foundation.

Your data

Company _____

Contact person _____

Street _____

Postal code _____

Location _____

Tel. _____

Fax _____

e-mail _____

Weld-on handle



Screw-on handle



Recessed handle



Please fill out and fax or mail to:

TORWEGGE conveying elements:

Fax: +49 521 93417-661
e-mail: info@torwegge.de

TORWEGGE Glauchau

Fax: +49 3763 5091-10
e-mail: glauchau@torwegge.de

Fittings for cantilever sliding gates

Slide rail galvanized and bare. Roller units and accessories galvanized.



Slide rail 6 m

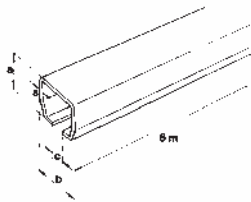

Order No.	For type	a mm	b mm	c mm	s mm	A	Dead weight/ m
9050/6	50	60	65	18	4	galv.	5.39 kg
9060/6	60	75	80	22	5	galv.	8.57 kg
9070/6	70	110	90	25	7	galv.	15.86 kg
9050N/6	50	60	65	18	4	Bright	5.39 kg
9060N/6	60	75	80	22	5	Bright	8.57 kg
9070N/6	70	110	90	25	7	Bright	15.86 kg

Roller units

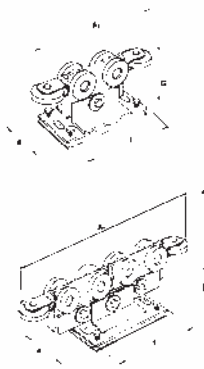

Order No.	For type	A mm	e mm	f mm	G mm	Load-carrying capacity kg
9952S	50	258	106	100	89	600
9962S	60	316	110	210	127	1000
9972S	70	371	165	300	162	1800
9968S	60	484	170	210	146	1200
9978S	70	632	200	300	164	2400

End roller

Order No.	For type
1050G	50
1060G	60
1070G	70



Entrance grip

Order No.	For type
1050E	50
1060E	60
1070E	70



Guide rollers

For screwing on, polyamide rollers, adjustable.

Order No.	1053
-----------	------



Guide roller

Made of polyamide, with M14 threads, diameter 44 mm.

Order No.	594/044
-----------	---------



Product portrait

Lifting gear



Electric chain hoists
Swivel arms
Manual trolleys
Electric trolleys
Clamping buffers



The TGM-Compact
The electric chain hoist is
supplied with chain box,
chain, and TGMCommander
and it is ready for
immediate installation.



Option: Remote control

Remote control option: Hoisting and lowering – wireless and independent of location with the radio-controlled Mini RC as part of our supplementary equipment. The receiver is simply plugged into the chain hoist in the place of the push button pendant.

Electric chain hoists for 230V or 400 V

TGM-ABUCompact for 230 V/50 Hz

Handy, immediately operational electric chain hoist with 230-V two-prong grounded plug, for **weights up to 200 kg**. The special advantages of the TGM-Compact: Due to the low dead weight and the possibility of connecting it via a normal 230-V outlet, this compact chain hoist can be utilized flexibly at workstations within enclosed halls. The speed can be **infinitely** adjusted via the TGMCommander (**up to 12 m per minute**).

Order No.	Load-carrying capacity kg	Chain strand No.	Infinitely adjustable travel m/min.	Hook travel m	FEM grading mm	Dead weight kg
TGMC100/03	100	1	0.7 – 12	3	1Am	10
TGMC100/06	100	1	0.7 – 12	6	1Am	11
TGMC100/10	100	1	0.7 – 12	10	1Am	12
TGMC100/20	100	1	0.7 – 12	20	1Am	14
TGMC200/03	200	2	0.3 – 6	3	1Am	12
TGMC200/06	200	2	0.3 – 6	6	1Am	13
TGMC200/10	200	2	0.3 – 6	10	1Am	15

The corresponding manual running gear THF3 can be found on page H 59.

Electric TGM ABUCompact chain hoists for 400 V/50 Hz

Torwegge electric chain hoists are particularly impressive through their practical and user-friendly advantages: A particularly low overall height, standard creep hoist, and brake pads with extremely long service lives as well as an extensive range of supplementary equipment. And with load-carrying capacities up to 4.0 t.

Scope of supply

Electric chain hoist ready for connection, complete with chain and chain box. Folding and removable suspension bracket. Control via push button pendant with "emergency stop." Hook travel 3 m.

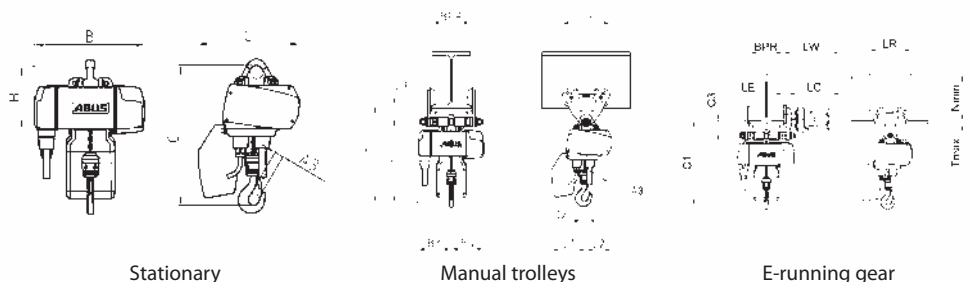

Stationary

Manual trolleys

E-running gear

Order No.	Load-carrying capacity kg	Chain strand No.	Main/ Creep hoist m/min.	FEM grading mm	Installation height			Dead weight kg
					C mm	C2 mm	C1 mm	
TGM2-125.8S	125	1	2/8	4m	344	357	–	22
TGM2-250.8S	250	1	2/8	2m	344	357	–	22
TGM2-500.4S	500	2	1/4	2m	425	394	–	25
TGM4-500.8S	500	1	2/8	2m	390	427	–	35
TGM4-1000.4S	1000	2	1/4	2m	470	527	–	38
TGM6-2000.4S	2000	2	1/4	2m	564	549	–	64
TGM6-2500.4S	2500	2	1/4	1Am	564	549	–	64
TGM8-3200.4S	3200	2	0,7/4	2m	674	816	–	101

*) For running gear orders, we require details of the flange width BPR of the profile.

Other designs are available on request.

- Load-carrying capacities 4000 kg

- Contactor control 48 V

- Electronic stroke limit switch

- Longer hook travel

- Radio-controlled Mini-RC

- Higher/lower hoisting speeds

We put things in motion

Product similar to illustrations!

Manual trolleys THF for single-rail trolley tracks



- Low installation height.
- Sturdy design with roller bearings.
- Practically maintenance-free.
- Machined rollers.
- Can be used for all standardized beams.
- Climbing and fall protection.
- Easy to adjust.
- Color blue.

Order No.	Load-carrying capacity kg	Flange width from - to mm	Total length mm	Height mm	Wheel Ø mm	Wheel tread Ø mm	Weight kg
THF3/42-120	300	42 - 120	165	135	56	75	3.9
THF3/121-180	300	120 - 180	165	135	56	75	4.4
THF6/42-120	600	42 - 120	205	153	65	85	6.1
THF6/121-220	600	121 - 220	205	153	65	85	6.7
THF14/64-125	1400	64 - 125	250	193	80	100	11
THF14/126-200	1400	126 - 200	250	193	80	100	11.7
THF14/201-300	1400	201 - 300	250	193	80	100	12.6
THF22/82-150	2200	82 - 150	320	236	112	140	23.2
THF22/151-200	2200	151 - 200	320	236	112	140	23.9
THF22/201-300	2200	201 - 300	320	236	112	140	25.8
THF36/90-155	3600	90 - 155	320	253	112	140	29.7
THF36/156-200	3600	156 - 200	320	253	112	140	30.4
THF36/201-300	3600	201 - 300	320	253	112	140	32.2
THF50/100-195	5000	100 - 195	400	348	140	180	65.5
THF50/200-305	5000	200 - 305	400	348	140	180	70.5

Max. bend radius on request.

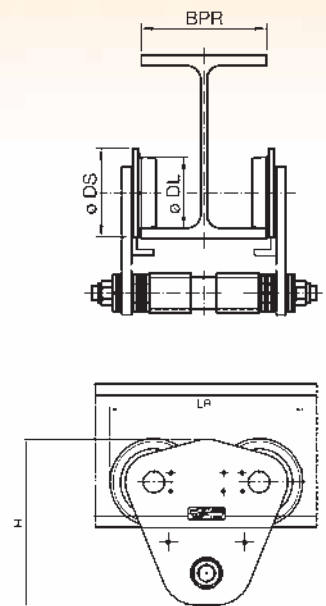

TEF electric trolleys for single-rail trolley tracks



Robust construction fitted with roller bearings - practically maintenance-free - machined rollers - can be used for all standardized beams - climbing and fall protection - easy to adjust - electromechanical, durable disc brake

- Color blue.
- Operating voltage 400V/50Hz.
- Driving speed 5/20 m/min.
- Protection class IP 55.
- Duty cycle 40%.

Order No.	Load-carrying capacity kg	Flange width from - to mm	Total length mm	Height mm	Wheel Ø mm	Wheel tread Ø mm	Weight kg
TEF14/64-125	1400	64 - 125	265	193	80	100	37.1
TEF14/126-200	1400	126 - 200	265	193	80	100	37.8
TEF14/201-300	1400	201 - 300	265	193	80	100	27.1
TEF22/82-150	2200	82 - 150	335	236	112	140	49.4
TEF22/151-200	2200	151 - 200	335	236	112	140	38.6
TEF22/201-300	2200	201 - 300	335	236	112	140	40.5
TEF36/90-155	3600	90 - 155	335	253	112	140	43.9
TEF36/156-200	3600	156 - 200	335	253	112	140	44.2
TEF36/201-300	3600	201 - 300	335	253	112	140	46.5
TEF50/100-195	5000	100 - 195	403	348	140	180	87.9
TEF50/200-305	5000	200 - 305	403	348	140	180	92.9

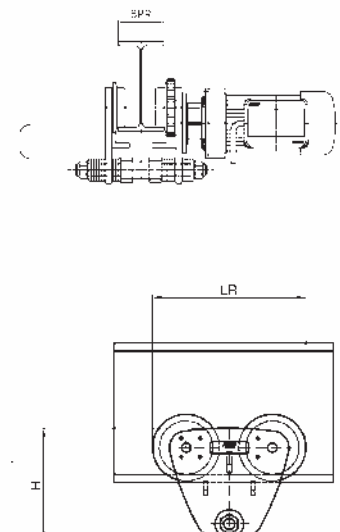

Clamping buffers TKP

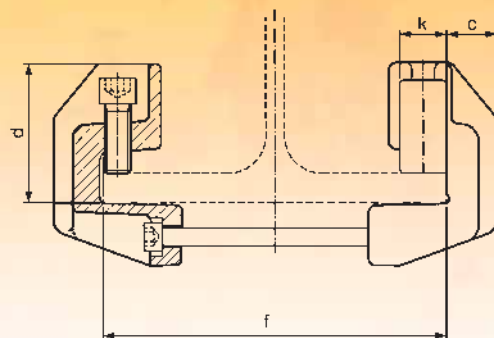

Selection table for trolley buffer form								
Design size	Dimensions in mm							Weight kg
	b	c	d	Rubber				
				a	e	g	k	
Alpha	110	20	63	45	40	15	26	2.6
Beta	170	32	90	80	60	35	30	5.9

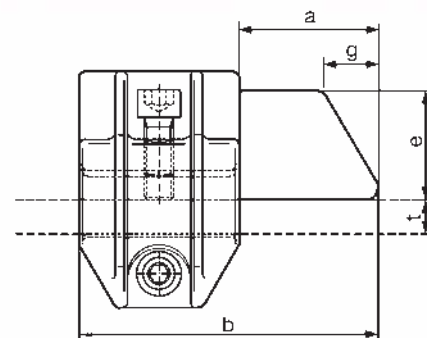

Order No.	Design size	Carrier		Use with ABUS electric chain hoist
		BPR mm	t mm	
TKP-Alpha/64-120	Alpha	64 – 120	≤ 20.5	ABUCompact TGMC to TGM8 Up to 2.0 t load-carrying capacity
TKP-Alpha/121-190		121 – 190	≤ 20.5	
TKP-Alpha/191-243		191 – 243	≤ 20.5	
TKP-Alpha/244-300		244 – 300	≤ 20.5	
TKP-Beta/110-160	Beta	110 – 160	≤ 30.0	ABUCompact TGM8 From 2.5 t to 4.0 t load-carrying capacity
TKP-Beta/161-230		161 – 230	≤ 30.0	
TKP-Beta/231-283		231 – 283	≤ 30.0	
TKP-Beta/284-340		284 – 340	≤ 30.0	

Trolley driver TKSM

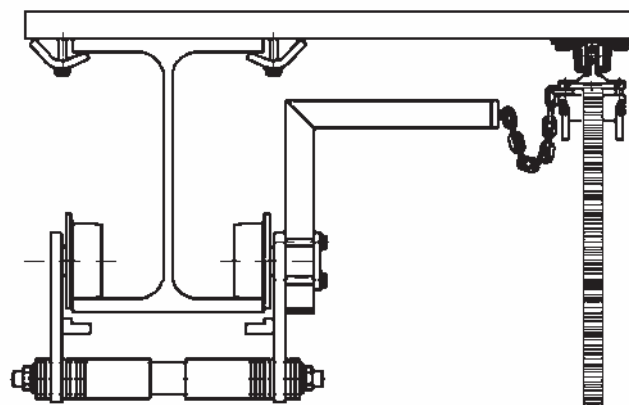

Order No.	Weight kg
TKSM	3.5

Wall-mounted jib crane with electric chain hoist

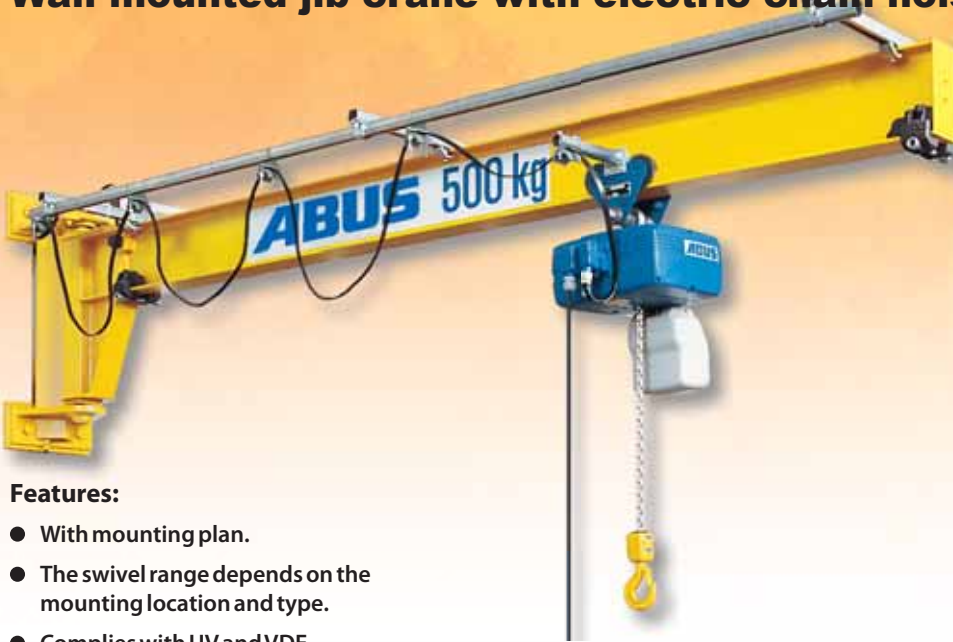

Features:

- With mounting plan.
- The swivel range depends on the mounting location and type.
- Complies with UV and VDE regulations.
- Complies with the German Equipment Safety Act.
- High-quality corrosion protection thanks to mechanical steel shot rust removal according to DIN 55928.
- Synthetic resin coating, RAL 1007 yellow.
- With complete electrical system consisting of lockable power cut-off switch and power supply line to the lifting gear.
- Mounting bolts must be provided by the customer.

Scope of supply

The crane

- Arm complete with wall mount.
- Electric chain hoist with push trolley.
- Mounting plan.
- Manual pivot.

The chain hoist

- High-quality electric chain hoist model TGM.
- Protection class IP 55.
- With tested safety chain.
- With chain case.
- With creep hoist.
- Operating voltage 400 V / 50 Hz.
- Control via safety buttons with mechanical contact locking.

Wall-mounted jib crane VW Medium-weight construction (DIN 15018 H2/B3)

Other features:

- Nominal swivel range 180°.
- Attachment via 2 wall brackets.
- Robust, low profile arm for a large usable hook height, adjustable trolley buffers, removable arm end plate.
- Attachment alternatives (on request)
- Via clamping bracket with weld-on plates.
- Other load-carrying capacities up to 4000 kg, projections, and electrical traction and swivel drives available on request.

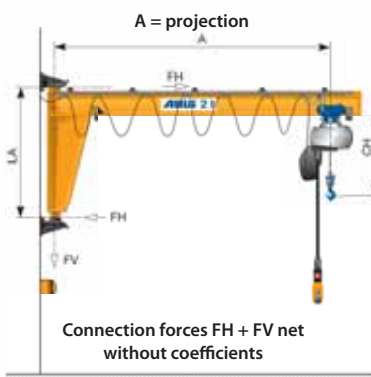

Order No.	Load-carrying capacity kg	Projection mm	Lift m/min.	Chain hoist	LA mm	CH mm	H1 mm	FH kN	FV kN	Weight kg
VW0250/3	250	3000	8/2	TGM2-250.8	630	382	345	16.3	4.33	192
VW0250/4	250	4000	8/2	TGM2-250.8	630	382	345	22.3	4.6	220
VW0250/5	250	5000	8/2	TGM2-250.8	1000	381	385	19.4	5.4	302
VW0250/6	250	6000	8/2	TGM2-250.8	1250	380	505	21.8	7.18	483
VW0250/7	250	7000	8/2	TGM2-250.8	1250	380	505	26.4	7.65	530
VW0500/3	500	3000	4/1	TGM2-500.4	630	485	345	28.4	6.9	205
VW0500/4	500	4000	4/1	TGM2-500.4	1000	484	385	25.2	7.6	278
VW0500/5	500	5000	4/1	TGM2-500.4	1250	483	505	27.5	9.3	448
VW0500/6	500	6000	4/1	TGM2-500.4	1250	483	505	33.9	9.8	496
VW0500/7	500	7000	4/1	TGM2-500.4	1250	481	565	43.6	11.3	657
VW1000/3	1000	3000	4/1	TGM4-1000.4	1250	528	505	27.8	13.4	367
VW1000/4	1000	4000	4/1	TGM4-1000.4	1250	528	505	37.4	13.9	414
VW1000/5	1000	5000	4/1	TGM4-1000.4	1250	526	565	49	15.2	546
VW1000/6	1000	6000	4/1	TGM4-1000.4	1250	526	565	60.1	15.8	608
VW1000/7	1000	7000	4/1	TGM4-1000.4	1600	525	605	57.6	17.3	762
VW2000/3	2000	3000	4/1	TGM6-2000.4	1250	631	565	52.7	24.1	461
VW2000/4	2000	4000	4/1	TGM6-2000.4	1600	630	605	56.1	25.4	588
VW2000/5	2000	5000	4/1	TGM6-2000.4	1600	629	695	72.4	27.8	830
VW2000/6	2000	6000	4/1	TGM6-2000.4	1600	629	695	88.1	28.6	912
VW2000/7	2000	7000	4/1	TGM6-2000.4	2000	627	745	85.4	30.7	1131

Prices including electric chain hoist and wall bracket, without mounting bolts.

Product similar to illustrations!

www.torwegge-group.com

Wall-mounted jib crane LW

Lightweight construction
(DIN 15018 H2/B2).

Other features:

- Nominal swivel range 180° profile arm manufactured from robust steel hollow sections, with wall bracket, smooth-running arm mount.

Attachment alternatives (on request):

- Via clasp bracket with weld-on plates.

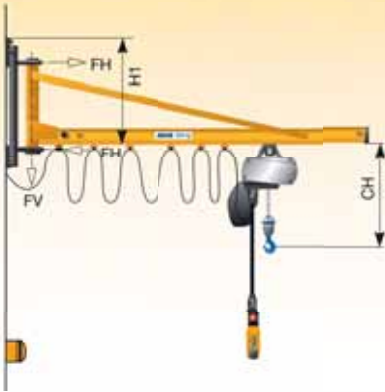

Prices including electric chain hoist and wall bracket, without mounting bolts.

Order No.	Load-carrying capacity kg	Projection mm	Lift m/min.	Chain hoist	LA mm	CH mm	H1 mm	FH kN	FV kN	Weight kg
LW0125/2	125	2000	8/2	TGM2-125.8	492	389	614	6	2.1	65
LW0125/3	125	3000	8/2	TGM2-125.8	492	389	614	9.6	2.2	78
LW0125/4	125	4000	8/2	TGM2-125.8	492	389	614	13.5	2.4	92
LW0125/5	125	5000	8/2	TGM2-125.8	492	389	614	17.6	2.5	104
LW0250/2	250	2000	8/2	TGM2-250.8	492	389	614	10.6	3.3	65
LW0250/3	250	3000	8/2	TGM2-250.8	492	389	614	16.7	3.5	78
LW0250/4	250	4000	8/2	TGM2-250.8	600	389	665	19.9	4	125
LW0250/5	250	5000	8/2	TGM2-250.8	600	389	665	25.9	4.2	146
LW0250/6	250	6000	8/2	TGM2-250.8	600	389	665	32.2	4.4	167
LW0500/2	500	2000	4/1	TGM2-500.4	600	470	665	16.5	6	85
LW0500/3	500	3000	4/1	TGM2-500.4	600	470	665	26	6.2	107
LW0500/4	500	4000	4/1	TGM2-500.4	600	470	665	35.8	6.4	128
LW0500/5	500	5000	4/1	TGM2-500.4	800	456	900	35.5	7.3	195
LW0500/6	500	6000	4/1	TGM2-500.4	800	456	900	43.8	7.6	223
LW1000/3	1000	3000	4/1	TGM4-1000.4	800	516	900	35.9	11.8	159
LW1000/4	1000	4000	4/1	TGM4-1000.4	800	516	900	49.9	12.1	187
LW1000/5	1000	5000	4/1	TGM4-1000.4	880	516	980	59.1	12.7	249

Other projections are available on request.

Wall-mounted jib crane LWX

Lightweight construction
(DIN 15018 H2/B2).

Other features:

- Nominal swivel range 180° Robust, low profile arm for a large usable hook height, with wall bracket, adjustable trolley buffers and removable arm end plate.

Attachment alternatives (on request):

- Via clasp bracket with weld-on plates.

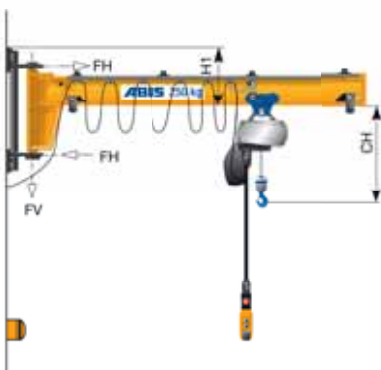

Prices including electric chain hoist and wall bracket, without mounting bolts.

Order No.	Load-carrying capacity kg	Projection mm	Lift m/min.	Chain hoist	LA mm	CH mm	H1 mm	FH kN	FV kN	Weight kg
LWX0125/2	125	2000	8/2	TGM2-125.8	492	383	296	5.6	2.5	125
LWX0125/3	125	3000	8/2	TGM2-125.8	492	383	296	8.9	2.7	145
LWX0125/4	125	4000	8/2	TGM2-125.8	600	383	350	12.1	3.3	206
LWX0125/5	125	5000	8/2	TGM2-125.8	600	383	350	16	3.5	227
LWX0125/6	125	6000	8/2	TGM2-125.8	800	383	452	16.6	4.6	340
LWX0250/2	250	2000	8/2	TGM2-250.8	492	383	296	9.4	3.8	130
LWX0250/3	250	3000	8/2	TGM2-250.8	600	383	350	13.7	4.3	183
LWX0250/4	250	4000	8/2	TGM2-250.8	600	383	350	19.1	4.6	214
LWX0250/5	250	5000	8/2	TGM2-250.8	800	383	452	19.4	5.6	311
LWX0250/6	250	6000	8/2	TGM2-250.8	800	383	452	24.3	5.9	342
LWX0500/2	500	2000	4/1	TGM2-500.4	600	669	350	15.7	6.7	183
LWX0500/3	500	3000	4/1	TGM2-500.4	600	469	350	24.5	6.9	203
LWX0500/4	500	4000	4/1	TGM2-500.4	800	469	452	25.5	7.8	300

Other projections are available on request.

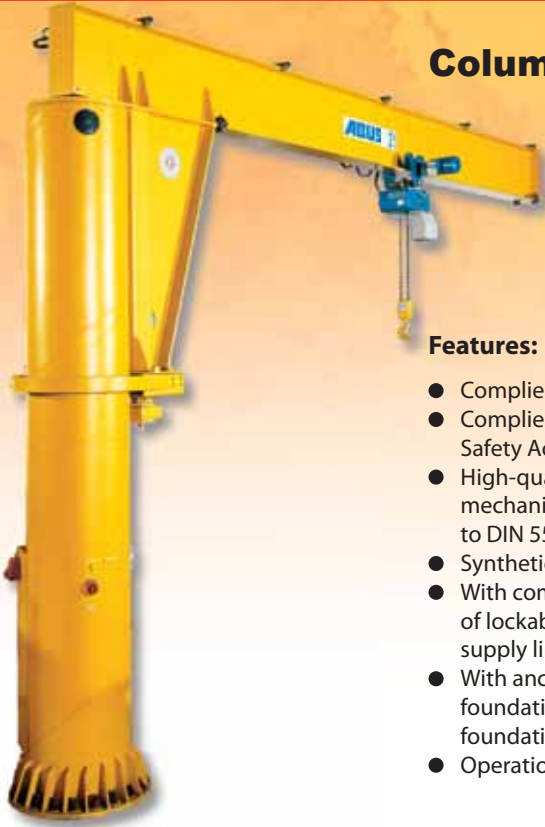

Column-mounted jib crane with electric chain hoist

Features:

- Complies with UV and VDE regulations.
- Complies with the German Equipment Safety Act.
- High-quality corrosion protection thanks to mechanical steel shot rust removal according to DIN 55928.
- Synthetic resin coating, RAL 1007 yellow.
- With complete electrical system consisting of lockable power cut-off switch and power supply line to the lifting gear.
- With anchor rods and template, as well as a foundation and reinforcement plan for the foundation.
- Operation in halls enclosed on all sides.

Scope of delivery:

The crane

- Column and arm complete with anchor rods and steel template.
- Electric chain hoist with push trolley.
- Complete electrical system.
- Foundation and reinforcement plan.
- Manual pivot.

The chain hoist

- High-quality electric chain hoist model TGM.
- Protection class IP 55.
- With tested safety chain.
- With chain case.
- With creep hoist.
- Operating voltage 400 V / 50 Hz.
- Control via safety buttons with mechanical contact locking.

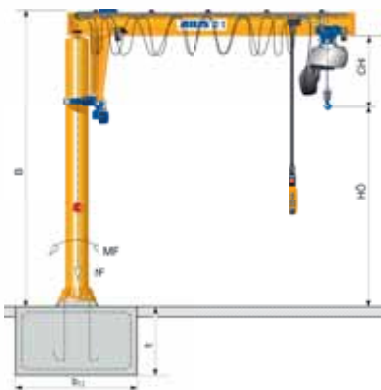

Column-mounted jib crane VW

Medium-weight construction (DIN 15018 H2/B3)

Other features:

- Height of lower edge of arm 3300 mm.
- Nominal swivel range infinite (360°).
- Robust, low profile arm for a large usable hook height.
- Adjustable trolley buffer, removable arm end plate.

Attachment alternatives (on request)

- On existing industrial floor space through the use of an intermediate plate with floor/ceiling anchors.
- Foundation attached via flush-fitting ideal anchors.
- The foundation can be driven over until crane is assembled.

Other load-carrying capacities up to 4000 kg, installation heights, projections, and electrical traction and swivel drives available on request.

Order No.	Load-carrying capacity kg	Projection mm	Lift m/min.	Chain hoist	B mm	CH mm	HÖ mm	b mm	t mm	MF kNm	NF kN	Weight kg
VS0250/3	250	3000	8/2	TGM2-250.8	3560	382	2918	1100	800	10.3	6.2	386
VS0250/4	250	4000	8/2	TGM2-250.8	3600	381	2919	1300	800	14.9	6.8	449
VS0250/5	250	5000	8/2	TGM2-250.8	3660	380	2920	1500	800	20.9	7.7	546
VS0250/6	250	6000	8/2	TGM2-250.8	3660	380	2920	1500	1000	26.7	9.3	706
VS0250/7	250	7000	8/2	TGM2-250.8	3720	378	2922	1600	1000	36.4	10.8	861
VS0500/3	500	3000	4/1	TGM2-500.4	3600	469	2831	1400	800	18.3	9.8	419
VS0500/4	500	4000	4/1	TGM2-500.4	3600	469	2831	1400	1000	25.2	10.4	567
VS0500/5	500	5000	4/1	TGM2-500.4	3720	466	2834	1600	1000	35.8	12.1	743
VS0500/6	500	6000	4/1	TGM2-500.4	3720	466	2834	1700	1000	44.6	13.3	865
VS0500/7	500	7000	4/1	TGM2-500.4	3720	466	2834	1900	1000	54.4	15.1	1044
VS1000/3	1000	3000	4/1	TGM4-1000.4	3660	528	2772	1600	1000	34.6	15.5	591
VS1000/4	1000	4000	4/1	TGM4-1000.4	3720	526	2774	1800	1000	48.1	17.2	763
VS1000/5	1000	5000	4/1	TGM4-1000.4	3720	526	2774	1900	1000	61.7	19	941
VS1000/6	1000	6000	4/1	TGM4-1000.4	3810	524	2776	2100	1000	79.6	20.8	1133
VS1000/7	1000	7000	4/1	TGM4-1000.4	3810	524	2776	2200	1000	95.5	22.9	1335
VS2000/3	2000	3000	4/1	TGM6-2000.4	3660	633	2667	1900	1000	65.7	27.5	805
VS2000/4	2000	4000	4/1	TGM6-2000.4	3720	631	2669	2100	1000	89.5	29.7	1038
VS2000/5	2000	5000	4/1	TGM6-2000.4	3860	627	2673	2300	1000	117.6	32.1	1279
VS2000/6	2000	6000	4/1	TGM6-2000.4	3860	627	2673	2500	1000	145	36.4	1716
VS2000/7	2000	7000	4/1	TGM6-2000.4	3910	626	2674	2700	1000	176	38.5	1926

Prices including electric chain hoist and anchoring material for attaching to foundation.

Column-mounted jib crane LS

Lightweight construction (DIN 15018 H2/B2)

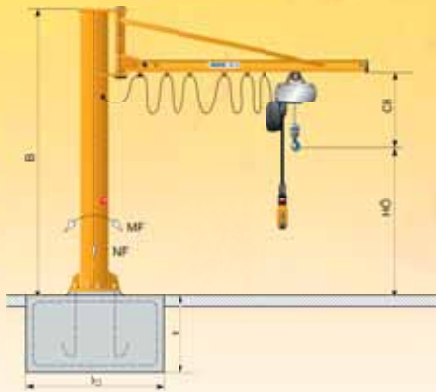

Other features:

- Height of lower edge of arm 2600 mm.
- Nominal swivel range infinite 270°.
- Profile arm and column made of robust steel hollow sections.
- Smooth-running arm mount.

Other installation heights and projections available on request.

Attachment alternatives (on request):

- On existing industrial floors through the use of anchor plate and composite anchors or via an intermediate plate with floor/ceiling anchors.
- Foundation attached via flush-fitting ideal anchors. The foundation can be driven over until crane is assembled.

Order No.	Load-carrying capacity kg	Projection mm	Lift m/min.	Chain hoist	B mm	CH mm	HÖ mm	b mm	t mm	MF kNm	NF kN	Weight kg
LS0125/2	125	2000	8/2	TGM2-125.8	3140	389	2211	800	800	3.4	3.2	213
LS0125/3	125	3000	5/2	TGM2-125.8	3140	389	2211	900	800	5.2	3.3	226
LS0125/4	125	4000	8/2	TGM2-125.8	3140	389	2211	1100	800	7.2	3.5	240
LS0125/5	125	5000	8/2	TGM2-125.8	3140	389	2211	1200	800	9.3	3.6	252
LS0250/2	250	2000	8/2	TGM2-250.8	3140	389	2211	1000	800	6	4.5	213
LS0250/3	250	3000	8/2	TGM2-250.8	3140	389	2211	1100	800	9	4.6	226
LS0250/4	250	4000	8/2	TGM2-250.8	3140	389	2211	1300	800	13	5.4	318
LS0250/5	250	5000	8/2	TGM2-250.8	3200	389	2211	1400	800	16.7	5.7	339
LS0250/6	250	6000	8/2	TGM2-250.8	3200	389	2211	1500	800	20.6	5.9	360
LS0500/2	500	2000	4/1	TGM2-500.4	3200	470	2130	1200	800	11.6	7.5	278
LS0500/3	500	3000	4/1	TGM2-500.4	3200	470	2130	1400	800	17.3	7.7	300
LS0500/4	500	4000	4/1	TGM2-500.4	3200	470	2130	1500	800	23.3	7.9	321
LS0500/5	500	5000	4/1	TGM2-500.4	3390	456	2144	1700	800	30.8	9.7	498
LS0500/6	500	6000	4/1	TGM2-500.4	3390	456	2144	1800	800	37.6	9.9	526
LS1000/3	1000	3000	4/1	TGM4-1000.4	3390	516	2084	1700	800	32.7	14.2	462
LS1000/4	1000	4000	4/1	TGM4-1000.4	3390	516	2084	1800	800	44	14.5	490
LS1000/5	1000	5000	4/1	TGM4-1000.4	3470	516	2084	2000	800	56.7	16.5	703

Prices including electric chain hoist and anchoring material for attaching to foundation.

Column-mounted jib crane LSX

Lightweight construction (DIN 15018 H2/B2).

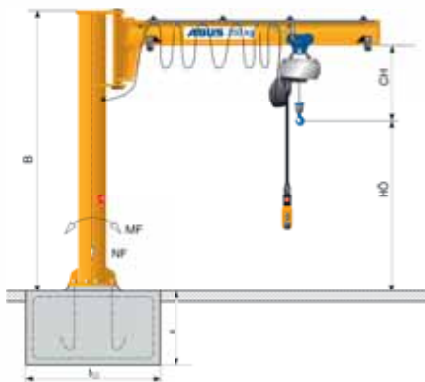

Other features:

- Height of lower edge of arm 2600 mm.
- Nominal swivel range infinite 270°.
- Robust, low profile arm for a large usable hook height, adjustable trolley buffers, removable arm end plate.

Other installation heights and projections available on request.

Attachment alternatives (on request):

- On existing industrial floors through the use of anchor plate and composite anchors or via an intermediate plate with floor/ceiling anchors.
- Foundation attached via flush-fitting ideal anchors. The foundation can be driven over until crane is assembled.

Order No.	Load-carrying capacity kg	Projection mm	Lift m/min.	Chain hoist	B mm	CH mm	HÖ mm	b mm	t mm	MF kNm	NF kN	Weight kg
LSX0125/2	125	2000	8/2	TGM2-125.8	2825	383	2217	800	800	4.2	4	261
LSX0125/3	125	3000	8/2	TGM2-125.8	2825	383	2217	1000	800	6.3	4.1	281
LSX0125/4	125	4000	8/2	TGM2-125.8	2890	383	2217	1100	800	9.3	5	385
LSX0125/5	125	5000	8/2	TGM2-125.8	2890	383	2217	1200	800	12	5.2	406
LSX0125/6	125	6000	8/2	TGM2-125.8	2950	383	2217	1400	800	17	7.3	611
LSX0250/2	250	2000	8/2	TGM2-250.8	2825	383	2217	1000	800	7	5.2	265
LSX0250/3	250	3000	8/2	TGM2-250.8	2825	383	2217	1200	800	10.9	6	362
LSX0250/4	250	4000	8/2	TGM2-250.8	2890	383	2217	1300	800	14.7	6.3	393
LSX0250/5	250	5000	8/2	TGM2-250.8	2950	383	2217	1400	800	20.2	8.3	581
LSX0250/6	250	6000	8/2	TGM2-250.8	2950	383	2217	1500	800	25	8.6	612
LSX0500/2	500	2000	4/1	TGM2-500.4	2890	469	2131	1200	800	13.3	8.4	362
LSX0500/3	500	3000	4/1	TGM2-500.4	2890	469	2131	1400	800	19.5	8.6	382
LSX0500/4	500	4000	4/1	TGM2-500.4	2950	469	2131	1600	800	27.1	10.5	570

Prices including electric chain hoist and anchoring material for attaching to foundation.

Electrical zero gravity balancer KROMATIC®

- Electronically controlled balancer with automatic load recognition.
- Triggering the lifting movement through lightly pressing the load up and down.
- High movement speed up to 30 m/min.
- Load hooks with quick-change coupling available.
- Simple attachment of special grippers possible.
- Only requires one 230-volt connection.
- Loads up to 60 kg.
- Infinitely adjustable drive.
- EMERGENCY STOP circuit.
- External inputs/outputs.
- Control behavior can be adapted to the user.
- Optional external changeover of the travel profile.
- Adjustable work stops.
- Integration in customer control system.
- Direct display of the load (9200).

KROMATIC® is always the first choice if changing loads need to be positioned infinitely variably and precisely. This intelligent assistant supports load handling in an effective manner. It includes many advantages all combined in a single device. This electric balancer effortlessly handles up to 60 kg of workpieces of various weights. Applications such as placing workpieces in machining equipment can be implemented easily, just as complex assemblies can be put together with accurate positioning. During this the **KROMATIC®** adjusts automatically to the weight of the load to be hoisted in a matter of seconds.

Diverse applications:

Hundreds of **KROMATIC®**'s around the world assist users handle loads easily and precisely. We cannot even name a typical application area for the **KROMATIC®**; the possibilities are so diverse.

However, here is a small overview of the areas of application:

- Automotive industry: e.g. cockpit assembly.
- Automotive industry: Assembly of windshields.
- Supplier industry: Preassembly of tanks.
- Production: e.g., equipping tool machines.
- Warehouse, shipping: Goods picking.
- Roof tile manufacturers: Changing the dies.
- Vehicle manufacturers: Handling rims.



KROMATIC®
designed to move

The technology:



Control unit 9100

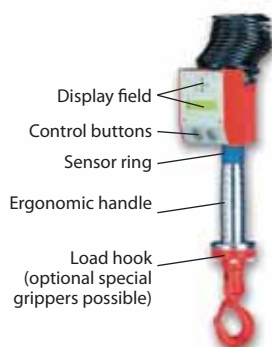

Control unit 9200

- Display field
- Control buttons
- Sensor ring
- Ergonomic handle
- Load hook (optional special grippers possible)

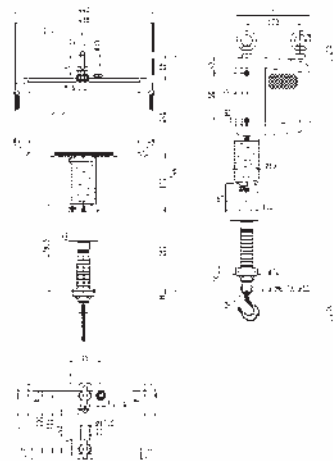

Jumbo vacuum hose lifter

Versatile hoisting and movement with just one medium.



The "Jumbo" vacuum hose lifter is particularly suitable for frequent and rapid lifting and moving of boxes, bags, barrels, wooden panels, and many other applications up to 300 kg in weight. The holding and lifting operation is achieved exclusively via a vacuum. Neither chains, wire ropes, manipulators, or lifting cylinders are necessary to grasp and securely raise the load. Suitable crane installations complete the system solution that is coordinated to the individual application.

Functionality:

- Gripping and lifting are achieved using a vacuum.
- The modular system consisting of variable, combinable basic components allows the equipment to be adapted to individual requirements.

Security:

- The quick-reacting check valve and large suction gripper surface prevent the load from dropping – even in the event of a power failure or a loss of compressed air.

- The design complies with the accident prevention regulations in accordance with BGR/BGV 500.

Ergonomics:

- Non-harmful working procedures through consideration of the latest ergonomic findings.



Jumbo-Flex with two-sided suction gripper

For clamped, glued, strapped, or open cartons, enclosures, etc.



Jumbo-Sprint with sack suction gripper

For paper and plastic bags, raw rubber balls, welded parcels, etc.



Jumbo-Ergo with quadruple suction gripper

For cartons, plates, and flexible parts, etc.



Jumbo-Ergo with two-sided suction gripper FM

For layers, pallets, plates with holes, aluminum profiles, etc.

VacuMaster vacuum lifters

The groundbreaking generation of vacuum lifters!



VacuMaster vacuum lifters are ideal for handling sheet metal, windowpanes, wood and concrete panels, and other materials weighing up to 2000 kg. Gripping is performed by the VacuMaster. The load can be hoisted and moved safely with the help of a crane. Robustness and reliability are the main features of this product series.

Suitable crane installations complete the system solution that is coordinated to the individual application.



VacuMaster Basic/Comfort

Vacuum lifters with a high degree of variability.

- Individual adaptation of the equipment thanks to the compact, modular design.
- Ergonomic control handle.
- Safety is ensured via the electronic warning apparatus and check valve.
- Optionally available with 90° tilting and 180° rotating function.
- VacuMaster Comfort with ergonomically integrated control at the push of a button, with chain hoist included in delivery.

VacuMaster Eco

Self-priming vacuum lifter for all smooth, hermetically sealed workpieces.

- No power supply necessary.
- No installation costs.
- Ideal for changing locations.
- Safety ensured via acoustic warning apparatus with battery test function.
- Ergonomic control handle with integrated bracket for chain hoist control element.

Aluminum crane systems

Extremely ergonomic thanks to perfect smooth running properties!

Your advantages at a glance:

- Broad range of single-carrier, dual-carrier, and single-rail crane systems.
- Optimal ergonomics as a result of perfect, smooth movement.
- Simple installation thanks to innovative accessories.
- Inexpensive solution provided by the modular system.
- Weight-optimized aluminum profile (from 3 kg per running meter).
- Minimum delivery times for crane systems.
- High reliability through the use of ultra-modern materials.
- Loads up to 660 kg can be handled.
- Tested safety.



A suitable crane completes the vacuum lifting system that is coordinated with your application. In addition to the column- and wall-mounted jib crane, the aluminum crane system and the vacuum lifting system make an uncompromising unit.



Large crane profile range

- Different crane profiles (SRA 100, 105, 140, and 180) enable a weight-, load-, and cost-effective layout of the crane system.
- Depending on requirements, lengths up to 8 m can be manufactured.



Unique running gears

- Use of an ultra-modern technical plastic for smooth running and weight savings.
- Loads depending on design – up to 750 kg for each running gear unit.



High-quality chain hoists

- High degree of safety thanks to low voltage in the control element.
- High service life through stroke limit stop.
- Precise, workpiece-friendly positioning provided by 2-stage speed control.



Jib cranes

- Versatile, smooth-running cranes are available as wall- and column-mounted jib crane.
- Maximum load-carrying capacity 650 kg.
- Maximum arm length 6 m.

Aluminum crane systems

Load-carrying capacity up to 1500 kg.

Advantages of the aluminum crane systems:

- Perfect, smooth movement due to intelligent profile geometry.
- Optimal ergonomics due to low dead weight of the profiles.
- No tilting of the crane bridges possible.
- Highest possible flexibility through exterior grooves (compatible with item).
- 5 crane profiles, in combination with reinforcement profile 8 different combinations possible.
- One running gear size for all profiles.
- Compact height and approach dimensions.
- GS quality seal, safety factor of 4 for all load-carrying components.
- **Delivery times for complete crane systems up to 5 workdays.**
- **Delivery times for replacement parts up to 24 hours.**



Leaving technical changes!

Versions of the aluminum crane system



Monorail (ESB)

The simplest option for straight line transport.

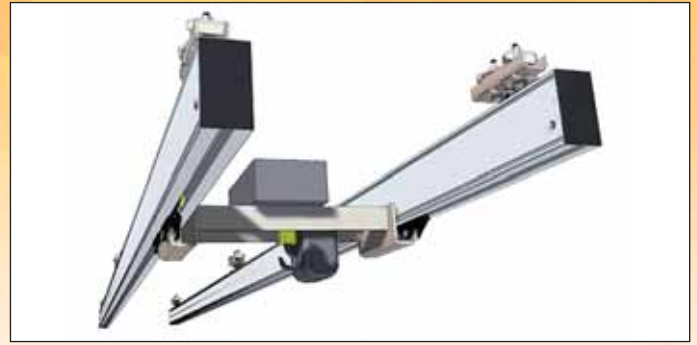

Duorail (ZSB)

Large support spacings, low hall impact, and a high hook position are enabled.



Single-carrier crane (ETK)

The ETK enables an optimum comprehensive option for material transport, with simple operation.



Single-carrier crane, raised (ETKA)

The ETKA is characterized by a very low installation height and optimum utilization of the room height.



Dual-carrier crane (ZTK)

The solution for the comprehensive transport of large loads.



Dual-carrier crane, raised (ZTKA)

The ZTKA combines the advantages of a raised system with that of the dual-carrier crane.



Curved track (EKB)

The curved segments are suitable as practical supplements.

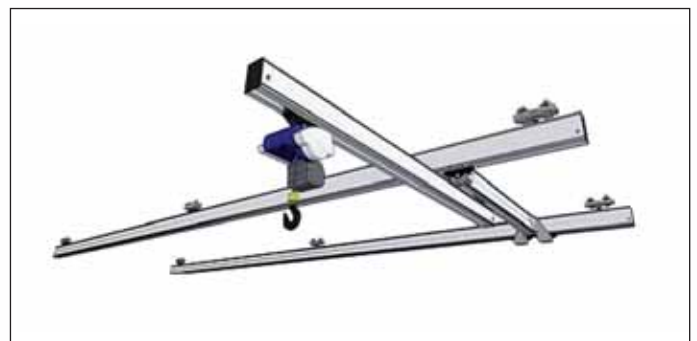

Single-carrier crane, raised telescopic (ETKA)

The ETKAT with the telescopic bridge can access hall areas previously not usable for a crane.

§ 1

Preamble

The terms and conditions specified below are applicable to all contracts which are concluded with our customers. Any deviating terms and conditions of our contracting parties have no binding effect for us. Any other terms shall then only be applicable if we have recognised the terms and conditions of our partners expressly and in writing.

§ 2

Offer and conclusion of contract

1. All offers on our part, whether they are in writing or delivered verbally, are not-binding with regard to their content and are only representative of an invitation to our contracting parties to submit a binding offer.

If one of our contracting parties responds to a not-binding offer on our part, then this response represents a request from our contracting parties to conclude a contract; silence on our part regarding this offer is always indicative that we have rejected this offer. The forwarding of our price lists, catalogues, brochures etc. to prospective customers does not obligate us to supply.

Any kind of information on our part only comes into legal effect if it is submitted in writing and signed by a coworker who is authorised to sign. We expressly assume no liability for any information verbally conveyed by our employees. Such information shall always be deemed to be non-committal.

2. Offers and orders shall be considered exclusively as accepted if they have been confirmed in writing or implemented by us within a timeframe of two weeks.

§ 3

Prices

1. Our prices are ex works, excluding the costs associated with packaging, customs duties, insurance and the statutory VAT (Value Added Tax).

2. Our invoices are payable net within 30 days of the invoice date. If payment is made within 10 days, we will grant a 2% discount. This discount will only be granted if all previous invoices have been paid.

3. Should the purchaser fall into arrears with payment, an interest on arrears of 8% above the respective base interest rate will be charged. Should we be able to provide evidence of a higher arrears damage, or if the customer is able to provide evidence that damage has not occurred in the amount claimed, then the interest rate shall be increased or lowered respectively. We shall have the right to lodge a claim for any damage caused by delay.

4. In the event of delayed payment or evidence of a substantial deterioration in the purchaser's financial situation after the conclusion of the contract, we shall have the right to make our services dependent on receipt of payments in advance or securities.

5. Counterclaims shall only be granted to the purchaser if his counterclaims are found to be undisputed or a valid title is present; he/she shall then only be able to assert a right of retention if it is based on requirements from the underlying contractual relationship.

6. In contracts in which the agreed delivery time is more than four months, we reserve the right to adjust prices in accordance with price increases due to tariff agreements or price increases in materials; this does not apply to goods or services which are delivered or effected in the framework of continuing obligations. The price adjustments will be communicated to the purchaser immediately.

§ 4

Delivery time

1. Delivery dates and times are only binding if these are agreed upon in writing. If specified delivery dates and times are not designated as binding expressly and in writing, then these are subject to change. Our compliance with our delivery obligation is based on the purchaser fulfilling his/her obligations properly and in a timely manner.

2. If delivery dates, which have been agreed upon in writing and are binding, have been exceeded then the purchaser is entitled to rescind from the contract according to §§ 651, 440, 323, 326 para. 5 BGB or a reduction in the purchase price according to § 441 BGB (BGB = Civil Law Code of the Federal Republic of Germany). A requirement for compensation by the purchaser shall be excluded if intent or gross negligence is not present on our part.

3. Cases of force majeure, operational disturbances or labour disputes occurring at our suppliers' premises or unforeseeable material defects which, through no fault of our own, prevent us from supplying the contractual item at the agreed upon date or within the agreed upon period, shall alter the contractually stipulated dates and periods for the duration of these disturbances. If corresponding disturbances result in a delay of more than four months, the purchaser is entitled to rescind from the contract. Other rights of withdrawal shall remain unaffected by this. In such cases we are obligated to inform the purchaser immediately of the type and extent of the disturbances we or our suppliers are experiencing.

§ 5

Warranty

1. Any claims asserted by the purchaser as a result of material defects after delivery of the ordered goods shall lapse after 24 months with a daily operation of 8 hours, after 12 months with a daily operation of 16 hours and after 6 months with a daily operation of 24 hours. If the purchaser accepts the contractual item despite knowledge of a defect, then he/she shall only be entitled to warranty claims if he expressly stipulates this during delivery. The claims of the purchaser shall remain unaffected in the event of fraudulent concealment of defects or the assumption of a warranty for the composition of the goods. Replaced parts become our property.

2. Unsuitable or inappropriate use, incorrect assembly or start-up operation by the purchaser or third parties, natural wear, incorrect or careless handling - particularly concerning excessive loads - are excluded from the scope of the warranty if we are not accountable for the defect.

3. Any alterations to the construction or configuration of parts already ordered, which we or our suppliers implement after the conclusion of a contract, do not result in cause for warranty claims on the part of the purchaser. Any warranty claims of the purchaser based on such measures are excluded, provided that the serviceability of the ordered parts is not substantially reduced in relation to the condition specified under the contract. The purchaser will be informed immediately by us of any alterations, as aforementioned, after we ourselves have obtained knowledge of such an issue.

4. Initially we shall always be entitled to the right to subsequent performance. The purchaser shall only be entitled to assert warranty claims in the event subsequent performance has not been effected within an appropriate period of time.

5. If the purchaser is a trader in the sense of the German Commercial Code (HGB), then any claims because of incomplete or incorrect delivery or objections because of a noticeable defect must be received immediately, however, at the latest 8 days after receipt of the contractual item. The burden of proof for ensuring the timeliness of receipt of the claim is to be borne by the purchaser. In all other respects the legal provisions apply. In the event of unpunctual notification of the objections or complaints concerning defects the entire scope of supply shall be deemed to be approved.

§ 6

Retention of ownership

1. The goods shall remain our sole property until full payment has been received. Should an account be settled by payment order or cheque, payment shall be considered as having been made once the funds have been credited to our account.

2. If the purchaser is a legal entity of public law, a public separate estate or a businessperson, who was acting in execution of his commercial or self-employed profession when the contract was agreed, then the retention of title shall continue to exist for our claims towards the purchaser from the current business relationship until all claims in connection with the delivery of the goods have been settled. On request of the purchaser we are obligated to relinquish the retention of title if the purchaser has incontestably fulfilled all claims concerning the object of purchase and reasonable security is provided for remaining claims from current business connections.

3. The purchaser shall have the right to sell the delivered goods in the normal course of business. This right may be revoked at any time. The resale may only take place in exchange for cash payment or under retention of title. The purchaser is not permitted to conduct transfers by way of security, pawning or other such methods. The purchaser hereby relinquishes all outstanding debts from a resale to us by way of security. On demand he/she has to transfer a list of the outstanding debts to us at any time and to inform the debtor of the transfer. However, he/she is entitled to recover the debts surrendered to us if he/she meets his/her payment obligations in accordance with the agreement.

4. We are under obligation to release the securities we are entitled to upon the purchaser's request if the value of our securities exceeds the claims to be secured by more than 20%.

5. The purchaser cannot acquire sole property of the delivery article by combining it with a new item. Any processing shall be implemented for us free of charge. In the event of a combination with other goods that do not belong to us, we are entitled to a joint ownership of the new item which is proportional to the value of our commodity in relationship to the other finished goods.

§ 7

Liability

1. If, due to the legal stipulations and in accordance with the requirements of these conditions, we have to make up for damage which was caused through inadvertent negligence, then we assume limited liability. Liability only exists for infringement of contractual obligations and is limited to typical damage foreseeable at the conclusion of a contract. This restriction does not apply to harm to life, body and health. If the damage is covered by insurance provided by the purchaser, we are only responsible for associated disadvantages faced by the purchaser, e.g. higher insurance premiums or interest disadvantages up to the claims settlement. We are not responsible for damage caused by a defect of the commodity as a result of inadvertent negligence.

2. Independent of blame on our part, any liability shall remain unaffected in the event of fraudulent concealment of defects, the assumption of a warranty or a procurement risk as well as in accordance with the product liability law.

3. Personal liability for damage caused by inadvertent negligence of auxiliary persons and staff members of our company is excluded.

4. Liability because of a delay in delivery is regulated under § 4.

§ 8

Copyright

We reserve the proprietary right and copyright for all drawings, sketches and samples we compile or hand over in connection with our service. These may not be handed over or made accessible to any third party without our express prior written consent and are to be returned immediately on request. The duplication of such items is only permissible within the framework of copyright laws or after our prior written consent.

§ 9

Governing law and place of fulfilment

1. The place of fulfilment is Bielefeld/Glauchau.

2. If the purchaser is a general merchant, a legal entity of public law or a separate estate under public law, the grievance for all disputes arising from the contractual relationship is to be filed at the court of jurisdiction for our place of business in Bielefeld; the court of jurisdiction for our premises in Glauchau for disputes below EUR 5,000.00 is Hohenstein-Ernstthal and for disputes in excess of EUR 5,000.00 the court of jurisdiction is Chemnitz.

3. The same court of jurisdiction shall apply if the purchaser does not have a domestic court of jurisdiction; it shall also apply if the address or habitual place of residence of the purchaser is unknown at the time the complaint is made or if the purchaser has transferred his/her address or habitual place of residence after conclusion of the contract.

4. The laws of the Federal Republic of Germany shall apply exclusively and are also applicable for business with foreign companies or deliveries abroad.

5. When sending written declarations to the purchaser, particularly confirmation of orders, proof that these have been sent by registered mail to the last-known address is sufficient.

§ 10

Severability clause

Should one or more of the above stated clauses be or become invalid, it/they shall not affect the validity of the remaining regulations. If a clause in these contract conditions becomes ineffective, then it shall be replaced by the stipulation that closest serves the economic purpose of the ineffective regulation. Alterations or additions to these conditions require express



Wheels & Casters
Conveyor Elements
Transport Technology
Materials Handling
Technology

Price list
(stood November 2012)

TORWEGGE

MATERIALS HANDLING TECHNOLOGY

2010 2011 2012 2013

www.torwegge-group.com

Ident. No. Order No. € UoM

H2 + H3

0030435	SGR01	538.18	pc.
0030436	SGR02	596.61	pc.
0030437	SGR03	589.87	pc.
0030438	SGR04	628.06	pc.
0030439	SGR11	1,046.03	pc.
0030440	SGR12	1,048.27	pc.
0030441	SGR14	1,115.69	pc.
0030442	SGR15	113.48	pc.
0030443	SGR17	1,230.29	pc.
0030444	SGR18	1,181.97	pc.
0030445	SGR19	1,276.35	pc.
0030446	SGR20	1,321.29	pc.
0030447	SGR21	1,390.96	pc.
0030448	SGR22	1,543.76	pc.
0030449	SGR23	1,512.30	pc.
0030450	SGR32	1,389.83	pc.
0030451	SGR36	1,480.84	pc.
0030452	SGR37	1,644.88	pc.
0030453	SGR38	1,550.50	pc.
0030454	SGR40	1,885.32	pc.
0030455	SGR53	1,577.47	pc.
0030456	SGR70	858.40	pc.
0030457	SGR71	928.05	pc.
0030458	SGR72	1,008.95	pc.
0030459	SGR73	1,065.13	pc.
0030460	SGR82	1,858.36	pc.
0030461	SGR90	2,010.03	pc.
0030462	SGR91	2,068.46	pc.
0030463	SGR92	2,250.47	pc.

H5

0030396	N084213-34x4x12	108.43	pc.
0030397	N084213-34x5x13	116.56	pc.
0030398	N084213-34x7x15	147.06	pc.
0030399	N084213-54x4x12	125.84	pc.
0030400	N084213-54x5x13	142.86	pc.
0030401	N084213-54x7x15	166.31	pc.
0030402	N084224-4	13.79	pc.
0030403	N084224-5	14.54	pc.
0030404	N084224-7	15.95	pc.
0030405	N084231-11	8.34	pc.
0030406	N084241-11	4.25	pc.
0030407	N084271	5.94	pc.
0030408	N084251-051	61.22	pc.
0030409	N084251-052	64.86	pc.
0030410	N084251-071	73.12	pc.
0030411	N084251-076	84.88	pc.
0030412	N084201-4x11	92.34	pc.
0030413	N084201-4x21	102.91	pc.
0030414	N084201-5x11	120.64	pc.
0030415	N084201-5x21	137.66	pc.
0030416	N084201-7x11x01	215.82	pc.
0030417	N084201-7x21x01	226.28	pc.
0030418	N084291-2	24.77	pc.

Ident. No. Order No. € UoM

H7

0014019	7200/1 1600 MM SEIL	56.18	pc.
0019441	7200/2 1600 MM SEIL	66.29	pc.
0014029	7211/1-2 2000 MM SEIL	84.27	pc.
0034148	7211/2-2 2500 MM SEIL	88.76	pc.
0014038	7221/1-3 3000 MM SEIL	215.72	pc.
0014040	7221/2-3 3000 MM SEIL	229.21	pc.
0014042	7221/3-3 3000 MM SEIL	241.57	pc.
0014044	7221/4-3 3000 MM SEIL	253.92	pc.
0014047	7222/1 3000 MM SEIL	240.44	pc.
0014049	7222/2 3000 MM SEIL	261.79	pc.
0014051	7222/3 3000 MM SEIL	267.41	pc.
0014053	7222/4 3000 MM SEIL	278.64	pc.

H8

0034801	7228/1 1600 MM SEIL	110.11	pc.
0034804	7228/2 1600 MM SEIL	115.17	pc.
0034805	7228/3 1600 MM SEIL	116.85	pc.
0034806	7228/4 1600 MM SEIL	121.35	pc.
0034807	7228/5 1600 MM SEIL	128.09	pc.
0014064	7230/1 2000 MM SEIL	229.21	pc.
0014065	7230/2 2000 MM SEIL	231.45	pc.
0014066	7230/3 2000 MM SEIL	238.19	pc.
0014067	7230/4 2000 MM SEIL	249.99	pc.
0014068	7230/5 2000 MM SEIL	262.91	pc.
0014069	7231/1 2000 MM SEIL	328.07	pc.
0014070	7231/2 2000 MM SEIL	330.33	pc.
0014072	7231/3 2000 MM SEIL	334.82	pc.
0014073	7231/4 2000 MM SEIL	334.82	pc.
0014074	7231/5 2000 MM SEIL	339.31	pc.
0014153	7301/1 2300 MM SEILAUSSZUG	30.22	pc.
0014154	7301/2 2300 MM SEILAUSSZUG	30.22	pc.
0014155	7301/3 2300 MM SEILAUSSZUG	30.22	pc.
0014156	7302/1 2300 MM SEILAUSSZUG	47.18	pc.
0014157	7302/2 2300 MM SEILAUSSZUG	47.18	pc.
0014158	7302/3 2300 MM SEILAUSSZUG	47.18	pc.

H9

0014027	7211/1-1.6 1600 MM SEIL	29.66	pc.
0014030	7211/2-1.6 1600 MM SEIL	32.02	pc.
0014031	7211/3-1.6 1600 MM SEIL	33.82	pc.
0014034	7213/1-2.0 2000 MM SEIL	61.01	pc.
0014035	7213/2-2.0 2000 MM SEIL	69.89	pc.
0014036	7213/3-2.0 2000 MM SEIL	87.53	pc.
0014037	7213/4-2.0 2000 MM SEIL	99.43	pc.
0014039	7221/1-2.5 2500 MM SEIL	90.00	pc.
0014041	7221/2-2.5 2500 MM SEIL	99.43	pc.
0014043	7221/3-2.5 2500 MM SEIL	107.64	pc.
0014045	7221/4-2.5 2500 MM SEIL	120.78	pc.
0014046	7221/5-2.5 2500 MM SEIL	136.73	pc.
0014048	7222/1-2.5 2500 MM SEIL	103.59	pc.
0014050	7222/2-2.5 2500 MM SEIL	117.75	pc.
0014052	7222/3-2.5 2500 MM SEIL	128.42	pc.
0014054	7222/4-2.5 2500 MM SEIL	142.02	pc.

Ident. No. Order No. € UoM

0014094	7250/1-2.0 2000 MM SEIL	355.61	pc.
0014100	7250/2-2.0 2000 MM SEIL	375.04	pc.
0014102	7250/3-2.0 2000 MM SEIL	395.26	pc.
0014104	7250/4-2.0 2000 mm Seil	416.50	pc.
0014106	7250/5-2.0 2000 MM SEIL	455.60	pc.
0014108	7250/6-2.0 2000 MM SEIL	499.30	pc.
0014110	7250/7-2.0 2000 MM SEIL	534.25	pc.
0014113	7250/8-2.0 2000 MM SEIL	574.47	pc.
0014115	7250/9-2.0 2000 MM SEIL	654.91	pc.

H 12

0020473	N023200-4	9.69	m
0020475	N023200-6	9.69	m
0028932	N023400-4	50.20	m
0020573	N023400-6	50.20	m
0020611	N024100-4	16.12	m
0020613	N024100-6	16.12	m
0028933	N024109-4	83.98	m
0028934	N024109-6	83.98	m
0020437	N020662-30	0.57	pc.
0020438	N020662-40	1.02	pc.
0020487	N023210	6.58	pc.
0020627	N024105	12.75	pc.

H 13

0020488	N023215	1.88	pc.
0020490	N023219	4.01	pc.
0020489	N023218	7.19	pc.
0020629	N024110	5.30	pc.
0020630	N024111	9.50	pc.
0020483	N023203-250	140.69	pc.
0020484	N023203-400	125.31	pc.
0020485	N023203-600	130.74	pc.
0020486	N023203-800	135.24	pc.
0020477	N023203-1000	84.87	pc.
0020478	N023203-1200	87.09	pc.
0020479	N023203-1400	102.29	pc.
0020480	N023203-1600	109.84	pc.
0020482	N023203-2000	122.51	pc.
0020622	N024102-400	114.50	pc.
0020623	N024102-600	119.04	pc.
0020624	N024102-800	123.50	pc.
0020615	N024102-1000	103.98	pc.
0020616	N024102-1200	110.11	pc.
0020617	N024102-1400	115.19	pc.
0020618	N024102-1600	121.32	pc.
0020620	N024102-2000	141.12	pc.

Ident. No.	Order No.	€	UoM
H 14			
0020491	N023220	3.34	pc.
0020493	N023222	6.73	pc.
0020494	N023223	5.19	pc.
0020650	N024152	5.48	pc.
0020651	N024154	7.94	pc.
0020652	N024156	6.93	pc.
0020495	N023224	3.69	pc.
0020503	N023232	7.19	pc.
0020632	N024120	4.57	pc.
0020643	N024140	8.93	pc.
0020496	N023225	6.08	pc.
0020497	N023226	7.74	pc.
0020498	N023227	8.42	pc.
0020499	N023228	11.68	pc.
0020500	N023229	15.96	pc.
0020501	N023230	14.28	pc.
0020633	N024121	9.79	pc.
0020634	N024122	13.51	pc.
0020635	N024123	11.79	pc.
0020644	N024141	18.46	pc.
0020645	N024142	22.27	pc.
H 15			
0020506	N023241	8.29	pc.
0020640	N024131	9.35	pc.
0020507	N023242	8.29	pc.
0020641	N024132	9.35	pc.
0020505	N023240	6.80	pc.
0020639	N024130	9.35	pc.
0020502	N023231	9.66	pc.
0020504	N023233	15.94	pc.
0020636	N024125	10.59	pc.
0020647	N024144	17.60	pc.
H 16			
0020365	N020180-8	4.43	pc.
0020363	N020180-10	7.89	pc.
0020364	N020180-12	10.86	pc.
0020369	N020185-250	5.31	pc.
0020370	N020185-315	6.41	pc.
0020371	N020185-400	7.50	pc.
0020372	N020185-500	8.77	pc.
0020373	N020185-630	10.90	pc.
0020374	N020185-800	12.94	pc.
0020367	N020185-1000	15.98	pc.
0020368	N020185-1250	20.26	pc.
0020381	N020186-250	7.31	pc.
0020382	N020186-315	8.99	pc.
0020383	N020186-400	10.71	pc.
0020384	N020186-500	12.79	pc.
0020385	N020186-630	15.83	pc.
0020386	N020186-800	18.65	pc.
0020379	N020186-1000	23.39	pc.
0020380	N020186-1250	29.74	pc.

Ident. No.	Order No.	€	UoM
0020388	N020195-400	15.69	pc.
0020389	N020195-630	17.85	pc.
0020362	N020176-8X16	1.34	pc.
H 17			
0020410	N020280	26.26	pc.
0020412	N020282	28.88	pc.
0020411	N020281	30.82	pc.
0020413	N020283	33.19	pc.
0020414	N020284	35.32	pc.
0020415	N020285	35.98	pc.
0020428	N020286	15.10	pc.
0020391	N020206-500	19.86	pc.
0020392	N020206-630	22.41	pc.
0020393	N020206-800	28.52	pc.
0020390	N020206-1000	31.92	pc.
0020429	N020295	8.23	pc.
H 18			
0020591	N023941	15.57	pc.
0020594	N023951	18.39	pc.
0020600	N023971	19.69	pc.
0020593	N023943	10.56	pc.
0020595	N023953	12.95	pc.
0020601	N023973	14.70	pc.
0020514	N023261	16.57	pc.
0020515	N023263	20.52	pc.
0020522	N023271	22.66	pc.
0020679	N024240-80	23.82	pc.
0020678	N024240-125	27.10	pc.
0020680	N024241	28.75	pc.
0020516	N023265-100	21.61	pc.
0020517	N023265-125	24.45	pc.
0020523	N023275-100	23.10	pc.
0020524	N023275-125	25.99	pc.
0020681	N024242-100	25.66	pc.
0020682	N024242-125	27.92	pc.
0020683	N024243-100	27.11	pc.
0020684	N024243-125	29.44	pc.
0020541	N023330-105X100	44.95	pc.
0020543	N023330-125X100	47.02	pc.
0020542	N023330-105X160	52.60	pc.
0020544	N023330-125X160	54.66	pc.
0020545	N023330-140X100	46.72	pc.
0020548	N023330-160X100	48.79	pc.
0020546	N023330-140X160	54.49	pc.
0020549	N023330-160X160	56.54	pc.
0020550	N023330-180X100	49.71	pc.
0020552	N023330-200X100	51.79	pc.
0020551	N023330-180X160	57.49	pc.
0020553	N023330-200X160	59.55	pc.
0020659	N024210-100X100	47.90	pc.
0020661	N024210-125X100	49.78	pc.
0020660	N024210-100X160	55.19	pc.
0020662	N024210-125X160	57.28	pc.
0020663	N024210-135X100	49.78	pc.
0020665	N024210-160X100	51.68	pc.

Ident. No.	Order No.	€	UoM
0020664	N024210-135X160	52.63	pc.
0020666	N024210-160X160	59.24	pc.
0020667	N024210-175X100	52.96	pc.
0020669	N024210-200X100	54.86	pc.
0020668	N024210-175X160	60.54	pc.
0020670	N024210-200X160	62.42	pc.
H 19			
0020597	N023956	21.93	pc.
0020602	N023976	26.06	pc.
0020598	N023958	16.92	pc.
0020603	N023978	21.08	pc.
0020518	N023267	28.03	pc.
0020525	N023277	30.68	pc.
0020685	N024250	35.22	pc.
0020686	N024251	36.65	pc.
0020519	N023268-100	29.49	pc.
0020520	N023268-125	29.13	pc.
0020526	N023278-100	31.71	pc.
0020527	N023278-125	34.84	pc.
0020687	N024252-100	33.86	pc.
0020688	N024252-125	36.17	pc.
0020689	N024253-100	36.09	pc.
0020690	N024253-125	38.41	pc.
0020673	N024220-200X100	70.21	pc.
0020674	N024220-200X160	81.01	pc.
0020521	N023269	7.92	pc.
0020528	N023279	10.55	pc.
0020675	N024230-100X62	31.24	pc.
0020676	N024230-160X62	39.73	pc.
H 20			
0020605	N023991	19.28	pc.
0020607	N023993	12.65	pc.
0020529	N023291	20.02	pc.
0020702	N024313-80	25.74	pc.
0020701	N024313	30.69	pc.
0020530	N023291-125	24.13	pc.
0020691	N024306-100	28.94	pc.
0020692	N024306-125	31.24	pc.
0020695	N024310-100	42.47	pc.
0020696	N024310-125	44.16	pc.
0020697	N024310-160	47.61	pc.
0020698	N024310-200	54.17	pc.
H 21			
0020608	N023996	26.33	pc.
0020609	N023998	20.34	pc.
0020534	N023297	30.13	pc.
0020703	N024314	38.58	pc.
0020537	N023300-125	35.76	pc.
0020693	N024307-100	37.24	pc.
0020694	N024307-125	39.58	pc.
0020699	N024311	79.88	pc.
0020536	N023299	7.46	pc.
0020700	N024312	10.00	pc.

Ident. No. Order No. € UoM

H 22

0020531	N023293	22.31	pc.
0020532	N023293-125	28.19	pc.
0020704	N024316-100	30.90	pc.
0020705	N024316-125	33.22	pc.
0020709	N024320-100	42.33	pc.
0020710	N024320-125	43.64	pc.
0020711	N024320-160	45.66	pc.
0020712	N024320-200	47.08	pc.
0020706	N024317-175	56.98	pc.
0020707	N024317-200	59.35	pc.
0020713	N024321	71.12	pc.
0020535	N023298	11.18	pc.
0020708	N024318	11.53	pc.
0020714	N024322	23.24	pc.
0020512	N023258	14.22	pc.
0020754	N024512-80	19.00	pc.
0020513	N023259	16.36	pc.
0020753	N024512	25.08	pc.

H 23

0020750	N024510-160x100	39.59	pc.
0020563	N023361	9.88	pc.
0020565	N023363	11.07	pc.
0020567	N023365	19.45	pc.
0020569	N023367	11.21	pc.
0020718	N024330	9.80	pc.
0020720	N024332	11.56	pc.
0020722	N024334	23.56	pc.
0020564	N023362	7.48	pc.
0020566	N023364	8.59	pc.
0020568	N023366	16.95	pc.
0020570	N023368	8.43	pc.
0020719	N024331	7.04	pc.
0020721	N024333	9.01	pc.
0020723	N024335	16.71	pc.
0020554	N023351	19.18	pc.
0020557	N023353	20.66	pc.
0020558	N023355	29.27	pc.
0020572	N023373	25.74	pc.
0020715	N024323	26.60	pc.
0020716	N024324	28.04	pc.
0020717	N024325	36.61	pc.
0020724	N024340-100	25.28	pc.
0020725	N024340-125	29.79	pc.
0020729	N024342-100	29.00	pc.
0020730	N024342-125	36.03	pc.

Ident. No. Order No. € UoM

H 24

0028920	N023308-140x100	31.81	pc.
0028921	N023308-160x100	33.99	pc.
0028922	N023308-180x100	34.58	pc.
0028923	N023308-200x100	36.76	pc.
0028924	N023308-230x100	38.71	pc.
0028925	N023308-250x100	40.91	pc.
0020556	N023352-1ST	17.65	pc.
0020561	N023357-80	20.52	pc.
0020559	N023357-100	22.82	pc.
0020560	N023357-180	35.23	pc.
0028167	N023357-200	36.73	pc.
0026768	N024348-320	46.35	pc.

H 25

0020337	N020131-16	4.85	pc.
0020338	N020131-25	7.02	pc.
0020339	N020131-36	12.17	pc.
0020340	N020131-50	40.18	pc.
0020341	N020131-63	64.38	pc.
0020343	N020133-16	7.95	pc.
0020344	N020133-25	10.27	pc.
0020345	N020133-36	15.61	pc.
0020346	N020133-50	49.95	pc.
0020347	N020133-63	70.87	pc.
0020511	N023254	11.22	pc.
0020589	N023900	4.99	pc.
0020740	N024504	11.55	pc.
0020348	N020137-1x18	9.88	pc.
0020349	N020137-1x22	10.41	pc.
0020350	N020137-2x32	11.59	pc.
0020351	N020137-3x30	12.72	pc.
0020352	N020137-3x50	13.39	pc.
0020353	N020137-4x48	14.99	pc.

H 26

0020991	N047200-500	92.77	pc.
0020992	N047200-630	93.89	pc.
0020993	N047200-800	95.55	pc.
0020994	N047250-500	127.76	pc.
0020995	N047250-630	129.73	pc.
0020996	N047250-800	130.71	pc.
0020336	N020118-45x4	0.61	pc.
0020397	N020216-90x9	7.95	pc.
0020169	N020117-80	7.70	pc.
0020168	N020117-160	10.12	pc.
0020162	N020111-10	1.55	pc.
0020163	N020111-12.5	1.61	pc.
0020164	N020111-16	1.63	pc.
0020165	N020111-20	1.63	pc.
0020167	N020114	2.16	pc.

Ident. No. Order No. € UoM

H 27

0028926	N040241-0250	37.36	pc.
0028927	N040241-0500	40.40	pc.
0028928	N040241-1000	50.69	pc.
0028929	N040242-0250	37.49	pc.
0028930	N040242-0500	40.52	pc.
0028931	N040242-1000	50.60	pc.
0020828	N040243-1	102.33	pc.

H 30

0028981	N043612-370	67.52	pc.
0028985	N043614-450	84.03	pc.
0028989	N043616-450	141.50	pc.
0028982	N043622-400	102.64	pc.
0028986	N043624-475	131.85	pc.
0028990	N043626-475	187.78	pc.
0028983	N043632-560	160.18	pc.
0028984	N043642-560	228.97	pc.
0028969	N043653-500	157.26	pc.
0028979	N043655-630	263.39	pc.
0028980	N043665-630	327.28	pc.
0028970	N043663-500	204.42	pc.

H 32

0020878	N042211-2	466.62	pc.
0020879	N042211-3	569.47	pc.
0020880	N042211-4	633.25	pc.
0020881	N042211-5	751.35	pc.
0020882	N042211-6	796.08	pc.
0020904	N042213-2	386.63	pc.
0020905	N042213-3	480.92	pc.
0020906	N042213-4	538.02	pc.
0020907	N042213-5	650.42	pc.
0020908	N042213-6	687.55	pc.
0020844	N042201-2	466.62	pc.
0020845	N042201-3	569.47	pc.
0020846	N042201-4	821.81	pc.
0020847	N042201-5	935.93	pc.
0020848	N042201-6	1,104.65	pc.
0020854	N042203-2	386.63	pc.
0020855	N042203-3	480.92	pc.
0020856	N042203-4	726.59	pc.
0020857	N042203-5	896.05	pc.
0020858	N042203-6	996.10	pc.

Ident. No.	Order No.	€	UoM
0020630	N024111	9.50	pc.
0020770	N025115	12.98	pc.
0020789	N025617	18.72	pc.
0020807	N026117	27.70	pc.

H 45

0019894	N0145311-R45°	542.46	pc.
0019893	N0145311-L45°	538.76	pc.
0019895	N0145311-RL45°	663.80	pc.
0019897	N0145313-R90°	604.27	pc.
0019896	N0145313-L90°	604.27	pc.
0028699	N0145313-R/L90°	659.14	pc.
0019901	N0145315-R03 45°	614.13	pc.
0019899	N0145315-L03 45°	618.96	pc.
0019903	N0145315-RL03 45°	738.96	pc.
0019905	N0145317-R03 90°	680.30	pc.
0019904	N0145317-L03 90°	680.30	pc.
0019907	N0145317-RL03 90°	862.45	pc.
0019950	N0146311-R45°	631.08	pc.
0019949	N0146311-L45°	631.08	pc.
0019951	N0146311-RL45°	803.73	pc.
0019953	N0146313-R90°	708.71	pc.
0019952	N0146313-L90°	708.71	pc.
0019954	N0146313-RL90°	958.20	pc.
0019958	N0146315-R03 45°	705.29	pc.
0019956	N0146315-L03 45°	705.29	pc.
0019960	N0146315-RL03 45°	896.52	pc.
0019962	N0146317-R03 90°	776.85	pc.
0019961	N0146317-L03 90°	776.85	pc.
0019963	N0146317-RL03 90°	1,052.34	pc.
0020041	N0147311-R45°	940.15	pc.
0020040	N0147311-L45°	940.15	pc.
0020042	N0147311-RL45°	1,185.33	pc.
0020044	N0147313-R90°	1,108.49	pc.
0020043	N0147313-L90°	1,108.49	pc.
0020045	N0147313-RL90°	1,517.65	pc.
0020058	N0147315-R03 45°	1,026.47	pc.
0020047	N0147315-L03 45°	1,026.47	pc.
0020060	N0147315-RL03 45°	1,271.64	pc.
0020062	N0147317-R03 90°	1,194.82	pc.
0020061	N0147317-L03 90°	1,194.82	pc.
0020063	N0147317-RL03 90°	1,606.53	pc.
0020204	N0148311-R45°	1,277.17	pc.
0020203	N0148311-L45°	1,277.17	pc.
0020205	N0148311-RL45°	1,546.99	pc.
0020207	N0148313-R90°	1,434.42	pc.
0020206	N0148313-L90°	1,434.42	pc.
0020208	N0148313-RL90°	2,130.20	pc.
0020212	N0148315-R03 45°	1,231.93	pc.
0020210	N0148315-L03 45°	1,231.93	pc.
0020214	N0148315-RL03 45°	1,635.95	pc.
0020216	N0148317-R03 90°	1,523.76	pc.
0020215	N0148317-L03 90°	1,523.76	pc.
0020217	N0148317-RL03 90°	2,219.56	pc.

Ident. No.	Order No.	€	UoM
0019908	N0145361-01	1,899.62	pc.
0019909	N0145362-01	2,063.88	pc.
0019964	N0146361-01	2,035.96	pc.
0019965	N0146362-01	2,191.58	pc.
0020064	N0147361-01	3,620.19	pc.
0020065	N0147362-01	3,804.76	pc.
0020218	N0148361-01	4,839.08	pc.
0020219	N0148362-01	5,112.79	pc.

H 47

0019924	N0145911	109.50	pc.
0019925	N0145913	182.98	pc.
0019926	N0145921	371.96	pc.
0019927	N0145963	416.34	pc.
0019928	N0145964	346.44	pc.
0019979	N0146911	136.11	pc.
0019981	N0146921	455.94	pc.
0019980	N0146913	203.62	pc.
0019982	N0146963	457.76	pc.
0028700	N0146964	360.54	pc.
0020178	N0147911	174.13	pc.
0020180	N0147921	308.69	pc.
0020179	N0147913	229.93	pc.
0020181	N0147963	444.28	pc.
0020182	N0147964	373.11	pc.
0020081	N0148911	214.92	pc.
0020083	N0148921	415.95	pc.
0020082	N0148913	271.31	pc.
0020084	N0148963	458.28	pc.
0020085	N0148964	388.37	pc.

H 48

0019862	N0145010-12B	31.79	pc.
0019883	N0145110-12B	33.39	pc.
0019931	N0146010-B	41.38	pc.
0019947	N0146110-B	43.43	pc.
0020001	N0147010-B	75.51	pc.
0020012	N0147050-B	80.98	pc.
0020038	N0147110-B	79.31	pc.
0020185	N0148010-B	96.95	pc.
0020195	N0148050-B	103.32	pc.
0020201	N0148110-B	101.84	pc.
0019871	N0145020-12B	48.51	pc.
0019885	N0145120-12B	50.03	pc.
0019936	N0146020-B	60.80	pc.
0019948	N0146120-B	63.82	pc.
0020005	N0147020-B	109.58	pc.
0020014	N0147060-B	122.99	pc.
0020039	N0147120-B	115.14	pc.
0020189	N0148020-B	151.40	pc.
0020197	N0148060-B	165.74	pc.
0020202	N0148120-B	158.98	pc.

Ident. No.	Order No.	€	UoM
0019864	N0145011-12B	36.87	pc.
0019932	N0146011-B	45.86	pc.
0020002	N0147011-B	80.68	pc.
0020013	N0147051-B	88.67	pc.
0020186	N0148011-B	102.91	pc.
0020196	N0148051-B	108.45	pc.

H 49

0019873	N0145021-12B	54.87	pc.
0019939	N0146021-B	66.56	pc.
0020006	N0147021-B	117.90	pc.
0020015	N0147061-B	136.90	pc.
0020190	N0148021-B	161.27	pc.
0020198	N0148061-B	180.06	pc.
0019882	N0145093	13.13	pc.
0019946	N0146093	17.32	pc.
0020037	N0147093	35.55	pc.
0020200	N0148093	47.62	pc.

H 50

0019880	N0145092	25.87	pc.
0019945	N0146092	34.49	pc.
0020036	N0147092	70.39	pc.
0020199	N0148092	93.90	pc.
0019875	N0145024	49.47	pc.
0019940	N0146024	62.05	pc.
0020009	N0147025-1000	328.87	pc.
0020192	N0148024	154.34	pc.
0020682	N024242-125	27.92	pc.
0020521	N023269	7.92	pc.
0028957	N025270-125x80	28.87	pc.
0028960	N025290	10.22	pc.
0028958	N025770-125x80	33.73	pc.
0028961	N025790	35.25	pc.
0028959	N026270-125x80	36.16	pc.
0028962	N026290	36.25	pc.

H 51

0020705	N024316-125	33.22	pc.
0020708	N024318	11.53	pc.
0020780	N025396-125	31.94	pc.
0028954	N025398	16.24	pc.
0020799	N025896-125	39.01	pc.
0028955	N025898	18.22	pc.
0028953	N026396-125	40.01	pc.
0028956	N026398	19.67	pc.
0019867	N0145015-B	103.63	pc.
0019870	N0145018-12B	136.30	pc.
0019933	N0146015-B	126.68	pc.
0019934	N0146018-12B	163.50	pc.
0019876	N0145025-400	140.13	pc.
0019878	N0145028-12B-400	168.61	pc.
0019942	N0146025-400	182.35	pc.

Ident. No. Order No. € UoM

H 63

0010449	VS0250/3	3,392.00	pc.
0010450	VS0250/4	3,533.57	pc.
0010451	VS0250/5	3,785.24	pc.
0010452	VS0250/6	4,469.49	pc.
0010453	VS0250/7	4,757.12	pc.
0010454	VS0500/3	3,840.30	pc.
0010465	VS0500/4	4,289.72	pc.
0010467	VS0500/5	4,618.92	pc.
0010468	VS0500/6	5,196.43	pc.
0029073	VS0500/7	6,285.15	pc.
0010469	VS1000/3	4,516.68	pc.
0010470	VS1000/4	4,959.36	pc.
0010471	VS1000/5	5,260.46	pc.
0010472	VS1000/6	6,432.33	pc.
0010473	VS1000/7	7,758.12	pc.
0010474	VS2000/3	6,470.53	pc.
0010475	VS2000/4	6,891.86	pc.
0010476	VS2000/5	7,969.35	pc.
0010477	VS2000/6	9,004.14	pc.
0010478	VS2000/7	9,214.24	pc.

H 64

0010407	LS0125/2	2,314.52	pc.
0010409	LS0125/3	2,378.56	pc.
0010410	LS0125/4	2,442.60	pc.
0010411	LS0125/5	2,530.23	pc.
0010412	LS0250/2	2,314.52	pc.
0010413	LS0250/3	2,378.56	pc.
0010414	LS0250/4	2,675.18	pc.
0010415	LS0250/5	2,767.31	pc.
0013331	LS0250/6	2,874.05	pc.
0010416	LS0500/2	2,698.77	pc.
0010417	LS0500/3	2,770.67	pc.
0010418	LS0500/4	2,858.32	pc.
0010419	LS0500/5	3,771.76	pc.
0010420	LS0500/6	3,857.15	pc.
0010421	LS1000/3	3,951.53	pc.
0010423	LS1000/4	4,052.65	pc.
0010425	LS1000/5	4,695.32	pc.
0010426	LSX0125/2	2,766.18	pc.
0010428	LSX0125/3	2,840.34	pc.
0010430	LSX0125/4	3,078.53	pc.
0010432	LSX0125/5	3,130.21	pc.
0010434	LSX0125/6	3,436.94	pc.
0029071	LSX0250/2	2,792.03	pc.
0010435	LSX0250/3	3,013.36	pc.
0010437	LSX0250/4	3,078.53	pc.
0010439	LSX0250/5	3,365.04	pc.
0010441	LSX0250/6	3,436.94	pc.
0029072	LSX0500/2	3,178.52	pc.
0010442	LSX0500/3	3,238.07	pc.
0010444	LSX0500/4	3,521.21	pc.

Ident. No. Order No.

€ UoM

Ident. No. Order No.

€ UoM