



Company

Contact person/department

Date (order clarification and contract award)

Quotation or order number

Part number (MM up-to-date?)

- Type of press-in device: C-frame or portal
- Hydraulic or electric cylinder
- Press-in force /possibly press-in force determination
- Clear depth / clear width**
- Clear height**
- Stroke**
- Control variant 1 or 2
- What will be joined or separated?
- Will be positioned?
- Accuracy of force measurement 2 % of calibrated final value
- Precision stroke measurement 0.2 mm / 100 mm stroke
- Speeds - creep speed approx. 10–30 mm/s
- Speeds - rapid speed approx. 75–100 mm/s
- 2-hand panel or automatic mode (START push-button)
- Drilling pattern base plate as per catalogue
- Quick-disconnect coupling for tools
- Mounting aperture as per DIN 810
- Cycle time
- How many tools for the press plunger?
- How many tools for the base plate ?
- Protective covering
- With Macrolon windows or perforated plate
- With a door
- With Sick light grids
- Sketches of the components are available
- How many different joining components are there ?
- Desired delivery date of the customer
- Wherabouts of the press-in device

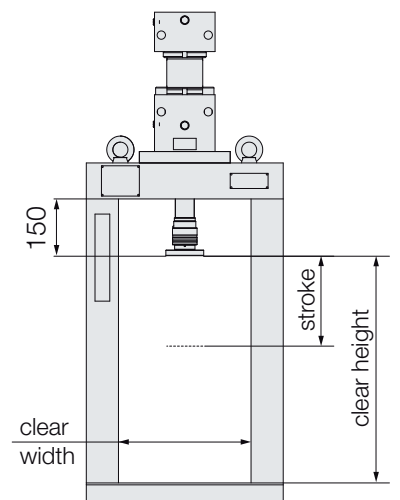
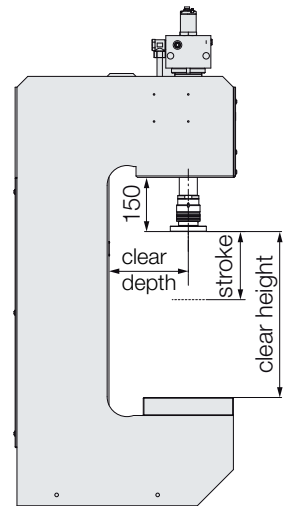

Other special features
