

Assembly recommendation

Use the experience of our experts and fill out the assembly recommendation. You will get an offer without obligation. Please tell us your requirements and choose your assembly situation.

Please fill out all fields marked with *

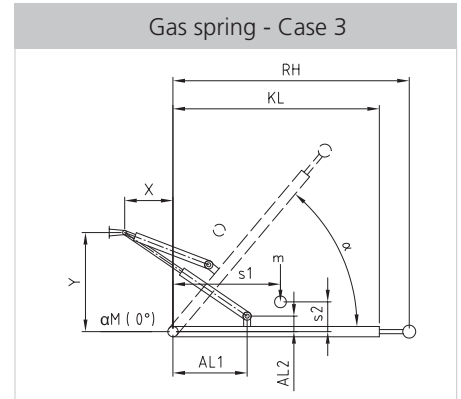
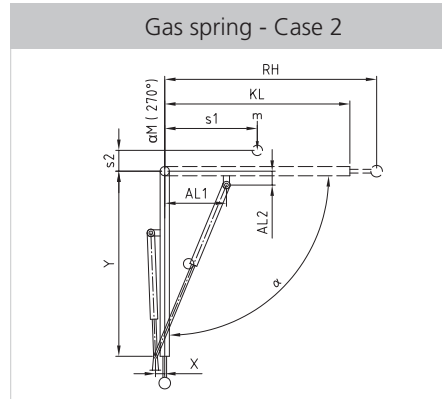
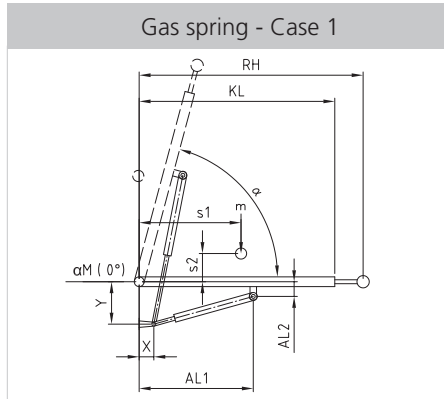

Required details

Moved mass * m kg

Center of mass s1 mm
s2 mm

Desired hand force N

Starting angle * α_M °

Opened angle * α °

Hatch length * KL mm

Radius handforce RH mm

Amount gas springs per hatch * n pcs.

End fittings

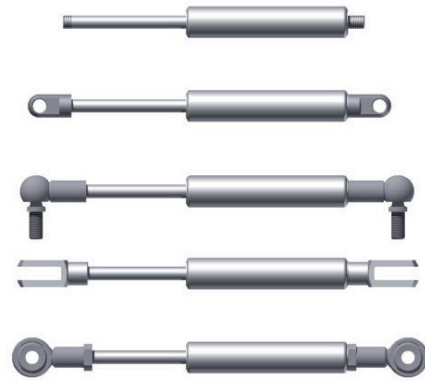

Operation area *

Material * Steel V2A V4A

Gas spring fixing point

If the mounting points of the gas spring are known just give data for the „min“ and „max“ distance.

If the assembly space for the gas spring is limited please show this indicating the data for „min“ and „max“ points.

Distance values

Fixed point

x-coordinate
x min mm x max mm

y-coordinate
y min mm y max mm

Mounting point

AL1 min mm AL1 max mm

AL2 min mm AL2 max mm

Contact details

Name *

Company *

Address *

ZIP / City*

Country

Telephone *

Fax

E-Mail *

Amount of springs

Order number

[Print enquiry](#)

[Send enquiry](#)