

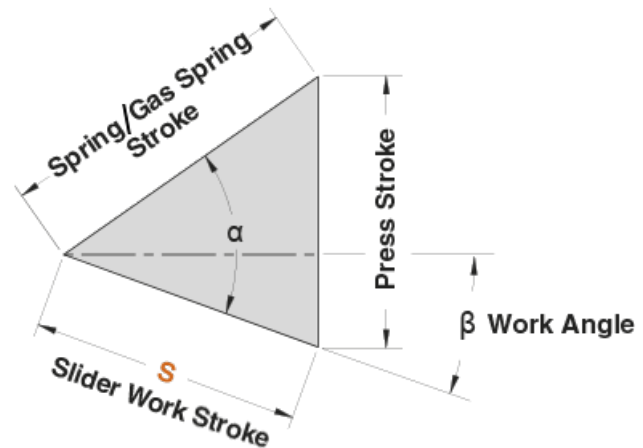

1. CAM DIAGRAM

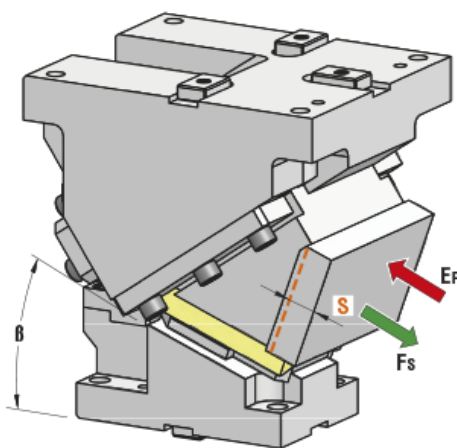

OMCR CODE	Work Angle β	Slider Work Stroke S (mm)	Press Stroke (mm)	Spring / Gas Spring Stroke (mm)	$\alpha - \beta$	α
CHD200.00	0°	28,68	40,96	50	55°	55°
CHD200.05	5°	32,26	41,11	50	50°	55°
CHD200.10	10°	35,90	41,59	50	45°	55°
CHD200.15	15°	39,65	42,40	50	40°	55°
CHD200.20	20°	43,59	43,59	50	35°	55°
CHD200.25	25°	47,78	45,19	50	30°	55°
CHD200.30	30°	52,33	47,29	50	25°	55°
CHD200.35	35°	57,36	50,00	50	20°	55°
CHD200.40	40°	63,05	53,47	50	15°	55°
CHD200.45	45°	69,64	57,92	50	10°	55°
CHD200.50	50°	77,49	63,72	50	5°	55°
CHD200.55	55°	87,17	71,41	50	0°	55°
CHD200.60	60°	99,62	81,92	50	-5°	55°
CHD200.65	65°	116,51	96,91	50	-10°	55°



2. WORK FORCE DISTRIBUTION (kN) FOR 1 MILLION CYCLES

The following diagrams illustrate the maximum possible ranges of camforce applicable in several portions of the work area but always working in the exact direction of slider work stroke. If several forces are applied simultaneously on the work area, their common center has to be specified and compared with the tabular infos. The sum of all forces has to be lower than the corresponding tabular value.

F_s

Max Work Force with shoulder

F_k
k

Max Work Force with fitting keys

Assembly with shoulder

$\beta=0^\circ \div 65^\circ$		WIDTH				
		35	35	40	35	35
HEIGHT	40	98	188	333	188	98
	40	117	223	396	223	117
	40	81	153	272	153	81

Assembly with fitting keys

$\beta=0^\circ \div 65^\circ$		WIDTH				
		35	35	40	35	35
HEIGHT	40	44	85	146	85	44
	40	53	100	153	100	53
	40	36	69	153	69	36