

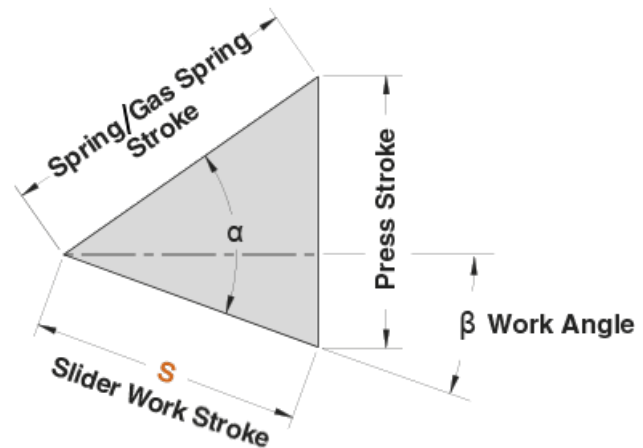

1. CAM DIAGRAM

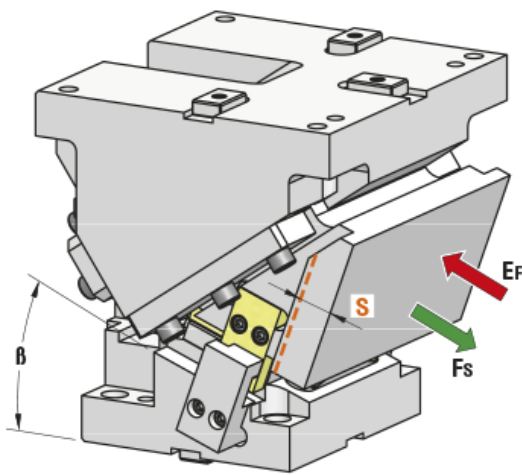

OMCR CODE	Work Angle β	Slider Work Stroke S (mm)	Press Stroke (mm)	Spring / Gas Spring Stroke (mm)	$\alpha - \beta$	α
CHD300.00	0°	28,68	40,96	50	55°	55°
CHD300.05	5°	32,26	41,11	50	50°	55°
CHD300.10	10°	35,90	41,59	50	45°	55°
CHD300.15	15°	39,65	42,40	50	40°	55°
CHD300.20	20°	43,59	43,59	50	35°	55°
CHD300.25	25°	47,78	45,19	50	30°	55°
CHD300.30	30°	52,33	47,29	50	25°	55°
CHD300.35	35°	57,36	50,00	50	20°	55°
CHD300.40	40°	63,05	53,47	50	15°	55°
CHD300.45	45°	69,64	57,92	50	10°	55°
CHD300.50	50°	77,49	63,72	50	5°	55°
CHD300.55	55°	87,17	71,41	50	0°	55°
CHD300.60	60°	99,62	81,92	50	-5°	55°
CHD300.65	65°	116,51	96,91	50	-10°	55°



2. WORK FORCE DISTRIBUTION (kN) FOR 1 MILLION CYCLES

The following diagrams illustrate the maximum possible ranges of camforce applicable in several portions of the work area but always working in the exact direction of slider work stroke. If several forces are applied simultaneously on the work area, their common center has to be specified and compared with the tabular infos. The sum of all forces has to be lower than the corresponding tabular value.



Max Work Force with shoulder



Max Work Force with fitting keys

Assembly with shoulder

		WIDTH					
		60	60	60	60	60	
HEIGHT	$\beta=0^\circ \div 65^\circ$	55	96	255	395	255	255
	50	156	417	645	417	417	
	55	103	275	425	275	275	

Assembly with fitting keys

		WIDTH					
		60	60	60	60	60	
HEIGHT	$\beta=0^\circ \div 65^\circ$	55	43	115	297	115	43
	50	70	188	297	188	70	
	55	46	124	297	124	46	