

1. CAM DIAGRAM

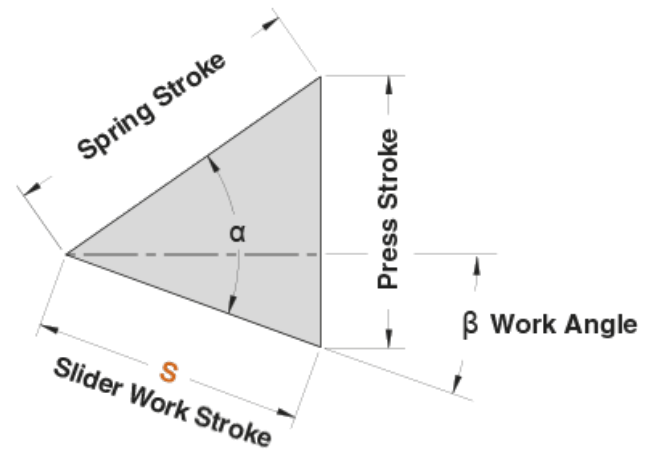

OMCR CODE	Work Angle β	Slider Work Stroke S (mm)	Press Stroke (mm)	Spring Stroke (mm)	$\alpha - \beta$	α
CHK200.00	0°	28,28	28,28	40	45°	45°
CHK200.10	10°	33,27	28,72	40	35°	45°
CHK200.20	20°	30,86	24,08	32	25°	45°
CHK200.30	30°	33,46	24,49	30	15°	45°
CHK200.40	40°	39,01	27,69	30	5°	45°
CHK200.50	50°	46,67	35,75	30	0°	50°
CHK200.60	60°	60,00	51,96	30	0°	60°
CHK200.70	70°	58,48	54,95	20	0°	70°

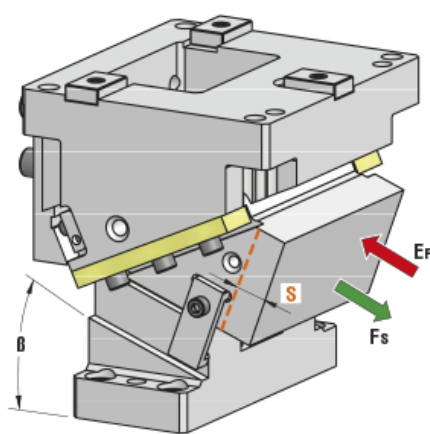

2. WORK FORCE DISTRIBUTION (kN) FOR 1 MILLION CYCLES

The following diagrams illustrate the maximum possible ranges of camforce applicable in several portions of the work area but always working in the exact direction of slider work stroke. If several forces are applied simultaneously on the work area, their common center has to be specified and compared with the tabular infos. The sum of all forces has to be lower than the corresponding tabular value.

F_s

Max Work Force with shoulder

F_k
k

Max Work Force with fitting keys

Assembly with shoulder

		WIDTH				
		40	40	40	40	40
HEIGHT	$\beta=0^\circ \div 70^\circ$	40	40	40	40	40
	40	93	127	165	127	93
	40	130	179	231	179	130
	40	65	89	115	89	65

Assembly with fitting keys

		WIDTH				
		40	40	40	40	40
HEIGHT	$\beta=0^\circ \div 70^\circ$	40	40	40	40	40
	40	42	57	82	57	42
	40	59	81	116	81	59
	40	29	40	58	40	29