

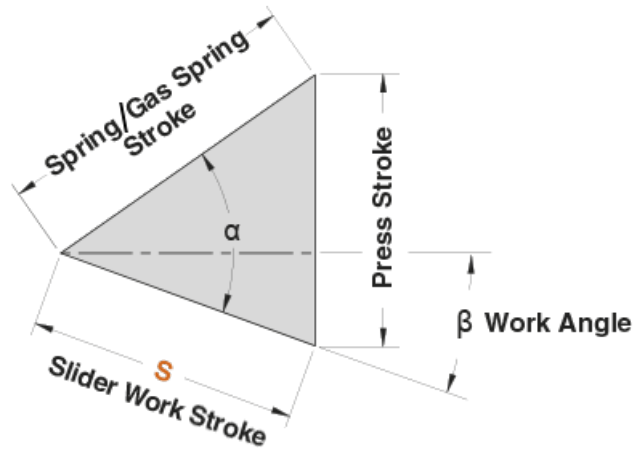

1. CAM DIAGRAM

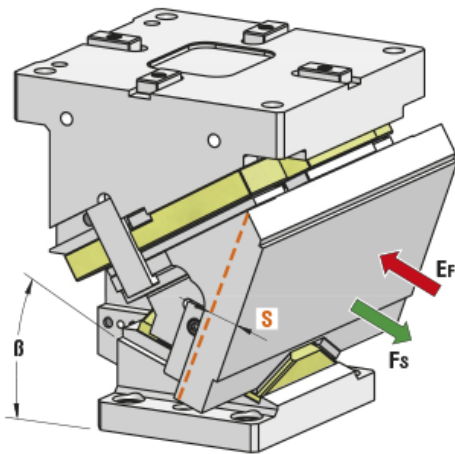

| OMCR CODE | Work Angle β | Slider Work Stroke S (mm) | Press Stroke (mm) | Spring / Gas Spring Stroke (mm) | $\alpha - \beta$ | α |
|-----------|--------------------|---------------------------|-------------------|---------------------------------|------------------|----------|
| CHR400.00 | 0° | 38,57 | 45,96 | 60 | 50° | 50° |
| CHR400.05 | 5° | 42,59 | 46,14 | 60 | 45° | 50° |
| CHR400.10 | 10° | 46,67 | 46,67 | 60 | 40° | 50° |
| CHR400.15 | 15° | 50,88 | 47,58 | 60 | 35° | 50° |
| CHR400.20 | 20° | 55,30 | 48,91 | 60 | 30° | 50° |
| CHR400.25 | 25° | 60,00 | 50,71 | 60 | 25° | 50° |
| CHR400.30 | 30° | 65,10 | 53,07 | 60 | 20° | 50° |
| CHR400.35 | 35° | 70,75 | 56,11 | 60 | 15° | 50° |
| CHR400.40 | 40° | 77,13 | 60,00 | 60 | 10° | 50° |
| CHR400.45 | 45° | 84,53 | 65,00 | 60 | 5° | 50° |
| CHR400.50 | 50° | 79,34 | 60,78 | 51 | 0° | 50° |
| CHR400.55 | 55° | 88,92 | 72,84 | 51 | 0° | 55° |
| CHR400.60 | 60° | 102,00 | 88,33 | 51 | 0° | 60° |



2. WORK FORCE DISTRIBUTION (kN) FOR 1 MILLION CYCLES

The following diagrams illustrate the maximum possible ranges of camforce applicable in several portions of the work area but always working in the exact direction of slider work stroke. If several forces are applied simultaneously on the work area, their common center has to be specified and compared with the tabular infos. The sum of all forces has to be lower than the corresponding tabular value.

F_s

Max Work Force with shoulder

F_k
k

Max Work Force with fitting keys

Assembly with shoulder

| | | WIDTH | | | | | | |
|--------|----|-------|-----|-----|------------|-----|-----|----|
| | | 50 | 60 | 60 | 60 | 60 | 60 | 50 |
| HEIGHT | 55 | 51 | 138 | 192 | 284 | 192 | 138 | 51 |
| | 50 | 94 | 253 | 351 | 521 | 351 | 253 | 94 |
| | 55 | 78 | 208 | 290 | 430 | 290 | 208 | 78 |

Assembly with fitting keys

| | | WIDTH | | | | | | |
|--------|----|-------|-----|-----|------------|-----|-----|----|
| | | 50 | 60 | 60 | 60 | 60 | 60 | 50 |
| HEIGHT | 55 | 23 | 62 | 86 | 142 | 86 | 62 | 23 |
| | 50 | 42 | 114 | 158 | 260 | 158 | 114 | 42 |
| | 55 | 35 | 94 | 130 | 215 | 130 | 94 | 35 |