



INDEX:

1 - Cam Diagrams	page
1.1 - CRX01.030	2
1.2 - CRX01.050	3
2 - Cam Driver Examples	4
3 - Work Force Distribution	6

Video instructions:

- **Roller cam units CRX01**



- **Gas spring removing or substitution**



1.1 - CRX01.030

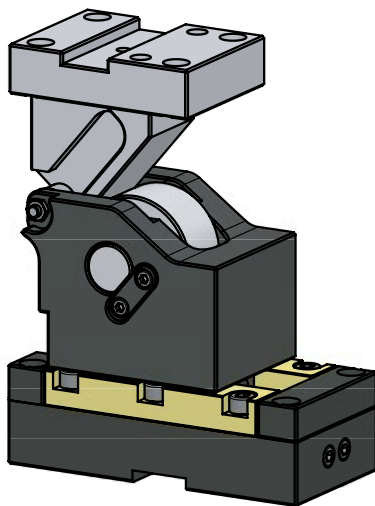
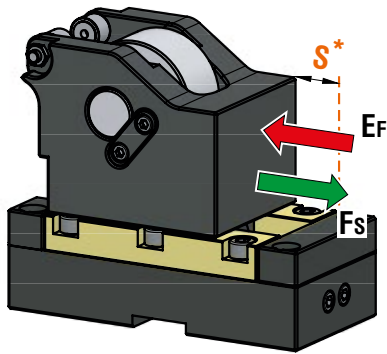

With Driver - **OPTION DRIVER**

OPTION DRIVER	Work angle (β)
H15	-15°
H10	-10°
H05	-5°
000	0
L05	5°
L10	10°
L15	15°
L20	20°
L25	25°
L30	30°
L35	35°
L40	40°
L45	45°
L50	50°

OMCR CODE	Stroke (mm)	Max Work Force (kN)	Extraction Force (kN)
			E_f
	S^*	F_s	Gas Spring
CRX01.030	30	45	2,5

* Do not exceed the maximum stroke

1.2 - CRX01.050

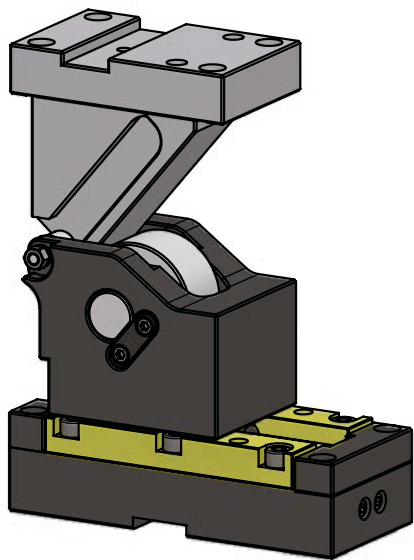
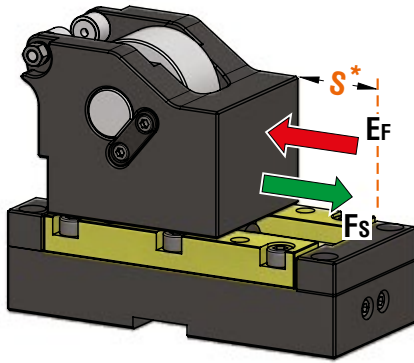

With Driver - **OPTION DRIVER**

OPTION DRIVER	Work angle (β)
H15	-15°
H10	-10°
H05	-5°
000	0
L05	5°
L10	10°
L15	15°
L20	20°
L25	25°
L30	30°
L35	35°
L40	40°
L45	45°
L50	50°

OMCR CODE	Stroke (mm)	Max Work Force (kN)	Extraction Force (kN)
			E_f
	S^*	F_s	Gas Spring
CRX01.050	50	45	3,4

* Do not exceed the maximum stroke

2 - Cam Driver Examples

WORK ANGLE (β) FROM -5° TO -15°

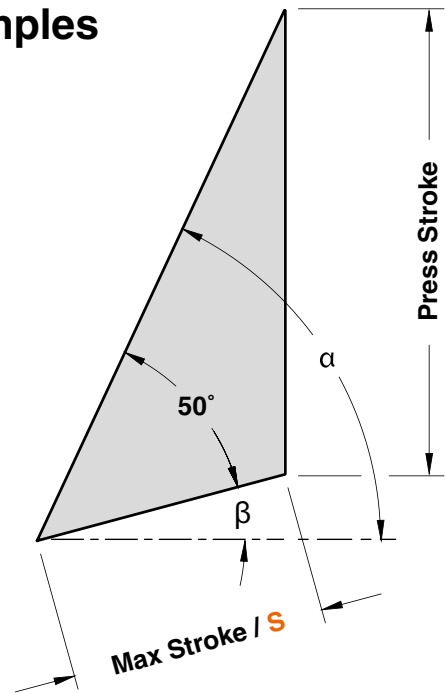
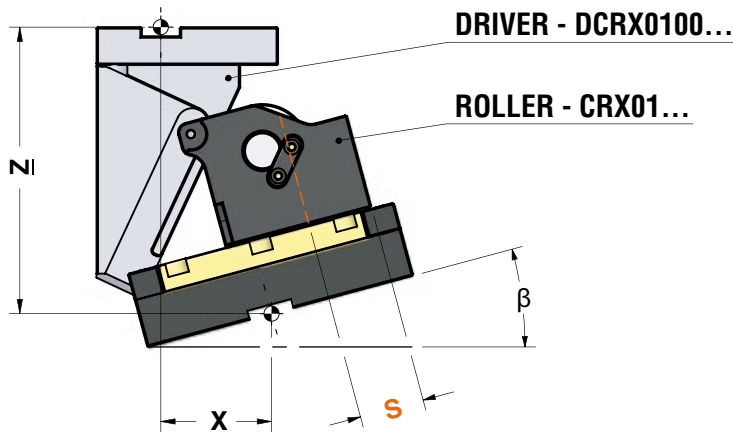

WORK ANGLE (β)= 0°

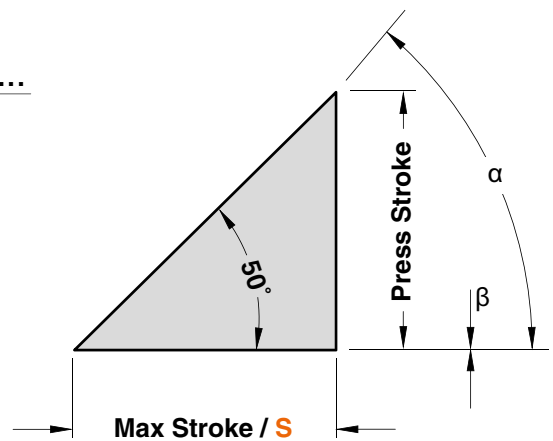
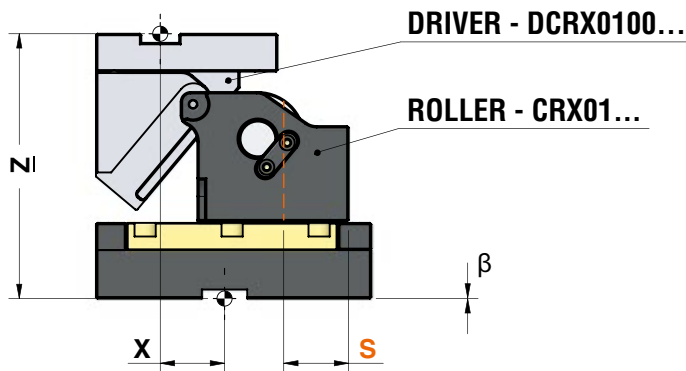

WORK ANGLE (β) FROM 5° TO 50°

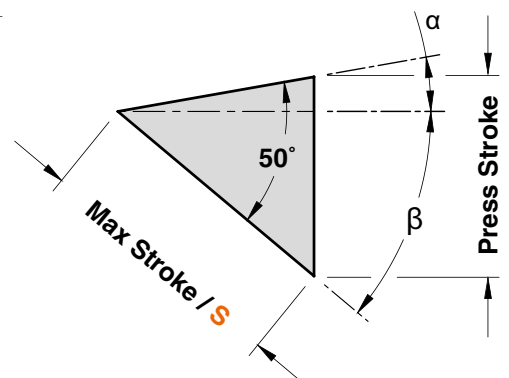
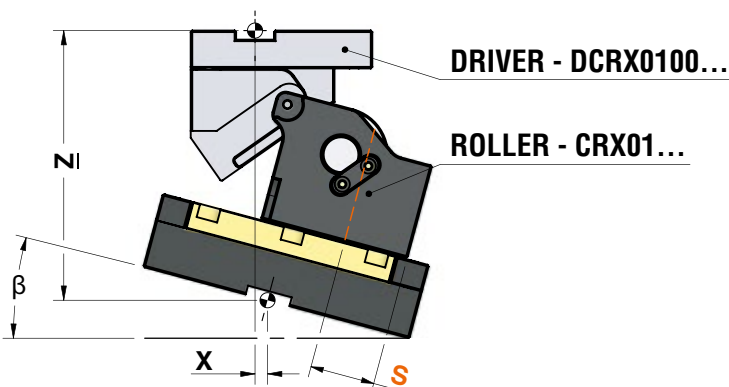



ROLLER CAM CODE	Work Angle β	α	Max Stroke S (mm)	Press Stroke (mm)	CAM DRIVER CODE	X (mm)	Z (mm)
CRX01.030	-15°	65°	30	54,4	DCRX0100.30.H15	73,20	175,60
	-10°	60°	30	46,0	DCRX0100.30.H10	63,49	174,00
	-5°	55°	30	40,1	DCRX0100.30.H05	53,23	169,90
	0°	50°	30	35,8	DCRX0100.30.000	42,50	175,00
	5°	45°	30	32,5	DCRX0100.30.L05	31,37	172,50
	10°	40°	30	30,0	DCRX0100.30.L10	19,93	175,00
	15°	35°	30	28,1	DCRX0100.30.L15	8,27	176,94
	20°	30°	30	26,5	DCRX0100.30.L20	-3,52	178,46
	25°	25°	30	25,4	DCRX0100.30.L25	-15,36	174,64
	30°	20°	30	24,5	DCRX0100.30.L30	-27,15	173,54
	35°	15°	30	23,8	DCRX0100.30.L35	-38,80	171,21
	40°	10°	30	23,3	DCRX0100.30.L40	-50,23	166,66
	45°	5°	30	23,1	DCRX0100.30.L45	-61,35	161,93
	50°	0°	30	23,0	DCRX0100.30.L50	-72,07	157,02
CRX01.050	-15°	65°	50	90,6	DCRX0100.50.H15	73,20	189,37
	-10°	60°	50	76,6	DCRX0100.50.H10	63,49	183,40
	-5°	55°	50	66,8	DCRX0100.50.H05	53,23	188,22
	0°	50°	50	59,6	DCRX0100.50.000	42,50	175,00
	5°	45°	50	54,2	DCRX0100.50.L05	31,37	179,83
	10°	40°	50	50,0	DCRX0100.50.L10	19,93	175,00
	15°	35°	50	46,8	DCRX0100.50.L15	8,27	178,24
	20°	30°	50	44,2	DCRX0100.50.L20	-3,52	175,77
	25°	25°	50	42,3	DCRX0100.50.L25	-15,36	172,74
	30°	20°	50	40,8	DCRX0100.50.L30	-27,15	169,24
	35°	15°	50	39,7	DCRX0100.50.L35	-38,80	170,35
	40°	10°	50	38,9	DCRX0100.50.L40	-50,23	161,11
	45°	5°	50	38,4	DCRX0100.50.L45	-61,35	156,55
	50°	0°	50	38,3	DCRX0100.50.L50	-72,07	151,70



3 - Work Force distribution (kN) for 1 million cycles

The following diagrams illustrate the maximum possible ranges of camforce applicable in several portions of the work area but always working in the exact direction of slider work stroke. If several forces are applied simultaneously on the work area, their common center has to be specified and compared with the tabular infos. The sum of all forces has to be lower than the corresponding tabular value.

F_s Max Work Force

		WIDTH		
		26	26	26
$\beta = -15^\circ \div 50^\circ$				
HEIGHT	21	11	45	11
	21	11	45	11
	21	11	45	11