



INDEX:

	page
1 - Cam Diagrams	
1.1 - CRX20.050	2
1.2 - CRX20.080	3
1.3 - CRX20.100	4
2 - Cam Driver Examples	5
3 - Work Force Distribution	6

Video instructions:

- **New CRX: from Option K to Option P**
- **Gas spring removing or substitution**





1.1 - CRX20.050

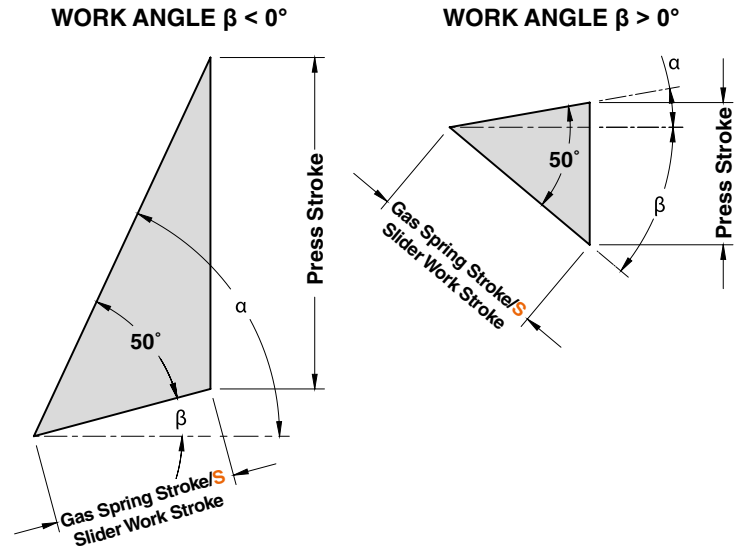
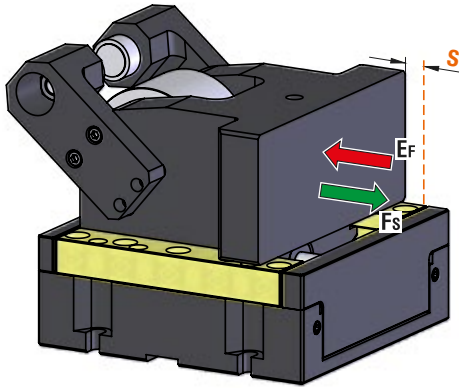

Roller Cam Driver Code	Roller Cam Code	Work Angle β	MAX Slider Work Stroke S^* (mm)	Press Stroke (mm)	MAX Gas Spring Stroke* (mm)	α
DCRX1520.50.H15	CRX20.050	-15°	50	90,63	50	65°
DCRX1520.50.H10		-10°	50	76,60	50	60°
DCRX1520.50.H05		-5°	50	66,78	50	55°
DCRX1520.50.H00		0°	50	59,59	50	50°
DCRX1520.50.L05		5°	50	54,17	50	45°
DCRX1520.50.L10		10°	50	50,00	50	40°
DCRX1520.50.L15		15°	50	46,76	50	35°
DCRX1520.50.L20		20°	50	44,23	50	30°
DCRX1520.50.L25		25°	50	42,26	50	25°
DCRX1520.50.L30		30°	50	40,76	50	20°
DCRX1520.50.L35		35°	50	39,65	50	15°
DCRX1520.50.L40		40°	50	38,89	50	10°
DCRX1520.50.L45		45°	50	38,45	50	5°
DCRX1520.50.L50		50°	50	38,30	50	0°

* It's recommended not to exceed 48 mm stroke for a safer gas spring application.

1.2 - CRX20.080

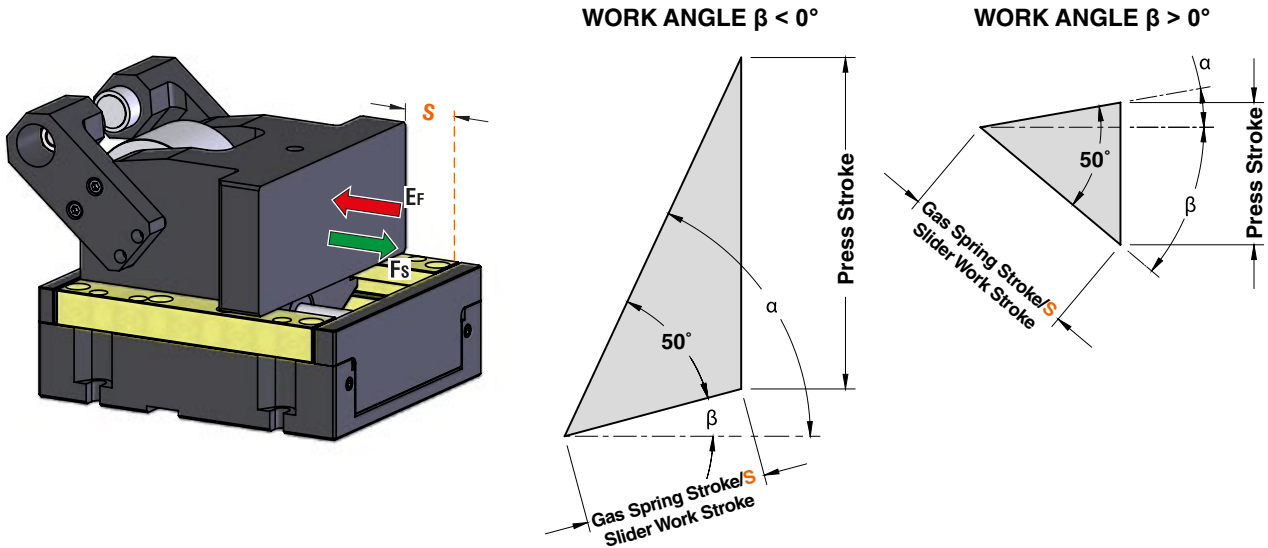

Roller Cam Driver Code	Roller Cam Code	Work Angle β	MAX Slider Work Stroke S^* (mm)	Press Stroke (mm)	MAX Gas Spring Stroke* (mm)	α
DCRX1520.80.H15	CRX20.080	-15°	80	145,01	80	65°
DCRX1520.80.H10		-10°	80	122,57	80	60°
DCRX1520.80.H05		-5°	80	106,84	80	55°
DCRX1520.80.H00		0°	80	95,34	80	50°
DCRX1520.80.L05		5°	80	86,67	80	45°
DCRX1520.80.L10		10°	80	80,00	80	40°
DCRX1520.80.L15		15°	80	74,81	80	35°
DCRX1520.80.L20		20°	80	70,76	80	30°
DCRX1520.80.L25		25°	80	67,62	80	25°
DCRX1520.80.L30		30°	80	65,22	80	20°
DCRX1520.80.L35		35°	80	63,45	80	15°
DCRX1520.80.L40		40°	80	62,23	80	10°
DCRX1520.80.L45		45°	80	61,52	80	5°
DCRX1520.80.L50		50°	80	61,28	80	0°

* It's recommended not to exceed 78 mm stroke for a safer gas spring application.

1.3 - CRX20.100

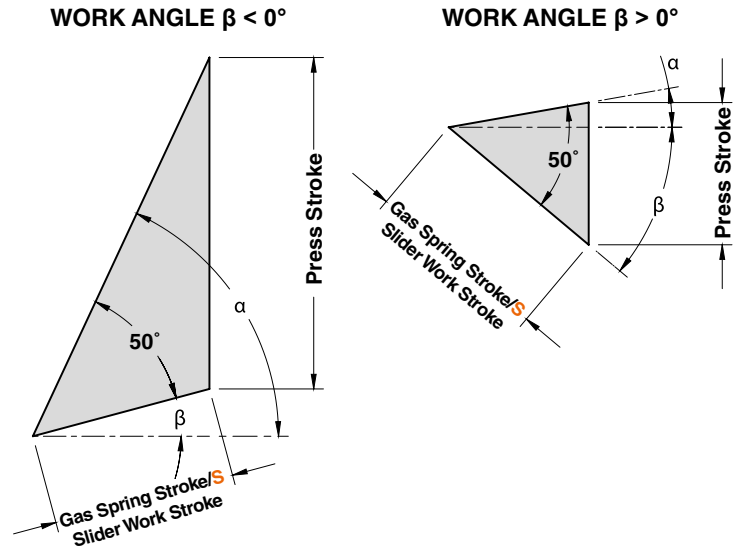
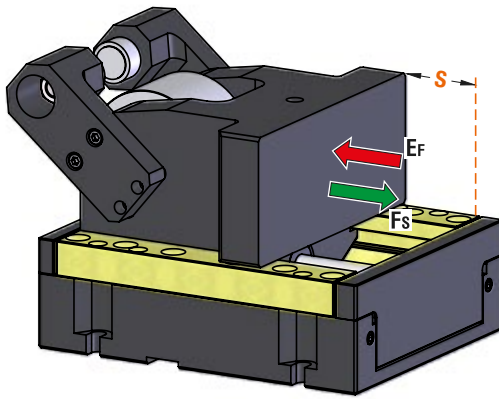

Roller Cam Driver Code	Roller Cam Code	Work Angle β	MAX Slider Work Stroke S^* (mm)	Press Stroke (mm)	MAX Gas Spring Stroke* (mm)	α
DCRX1520.80.H15	CRX20.100	-15°	100	181,26	100	65°
DCRX1520.80.H10		-10°	100	153,21	100	60°
DCRX1520.80.H05		-5°	100	133,56	100	55°
DCRX1520.80.H00		0°	100	119,18	100	50°
DCRX1520.80.L05		5°	100	108,34	100	45°
DCRX1520.80.L10		10°	100	100,00	100	40°
DCRX1520.80.L15		15°	100	93,52	100	35°
DCRX1520.80.L20		20°	100	88,46	100	30°
DCRX1520.80.L25		25°	100	84,52	100	25°
DCRX1520.80.L30		30°	100	81,52	100	20°
DCRX1520.80.L35		35°	100	79,31	100	15°
DCRX1520.80.L40		40°	100	77,79	100	10°
DCRX1520.80.L45		45°	100	76,90	100	5°
DCRX1520.80.L50		50°	100	76,60	100	0°

* It's recommended not to exceed 98 mm stroke for a safer gas spring application.

2 - Cam Driver Examples

EXAMPLE FOR:
CRX20.100.P
DCRX1520.80.H15

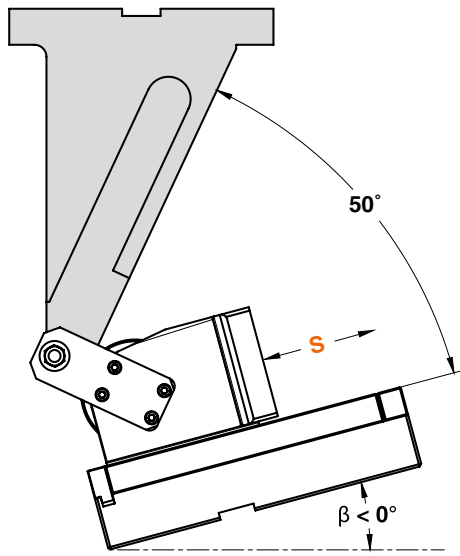

EXAMPLE FOR:
CRX20.100.K
DCRX1520.80.L40

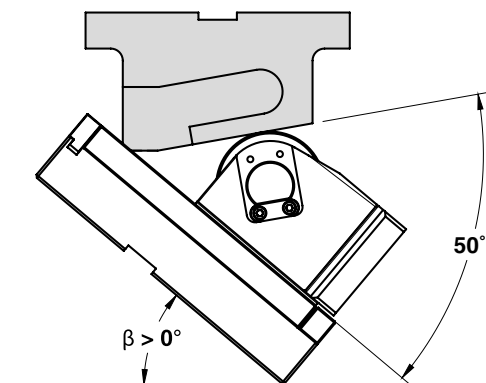
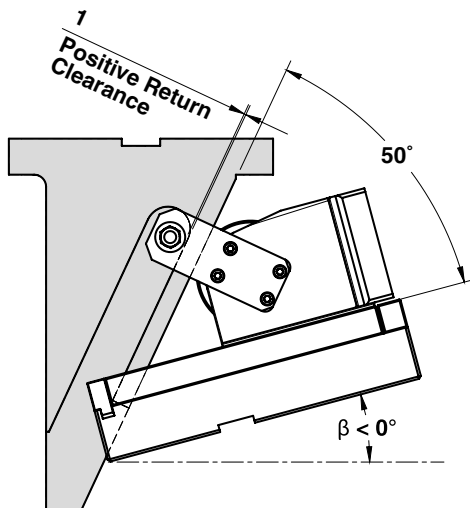
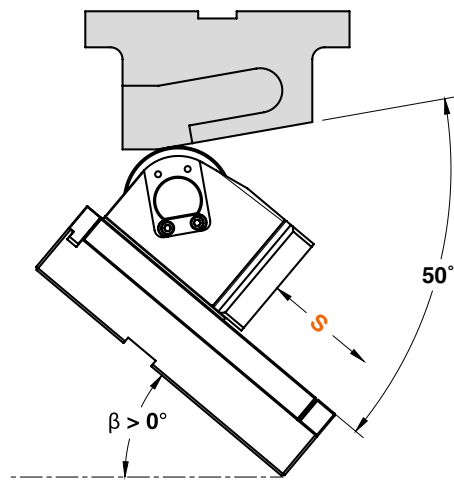



3 - Work Force distribution (kN) for 1 million cycles

The following diagrams illustrate the maximum possible ranges of camforce applicable in several portions of the work area but always working in the exact direction of slider work stroke. If several forces are applied simultaneously on the work area, their common center has to be specified and compared with the tabular infos. The sum of all forces has to be lower than the corresponding tabular value.

F_s Max Work Force

		WIDTH		
		80	80	80
$\beta = -15^\circ \div 50^\circ$				
HEIGHT	36	72	163	72
	38	106	258	106
	36	126	187	126