

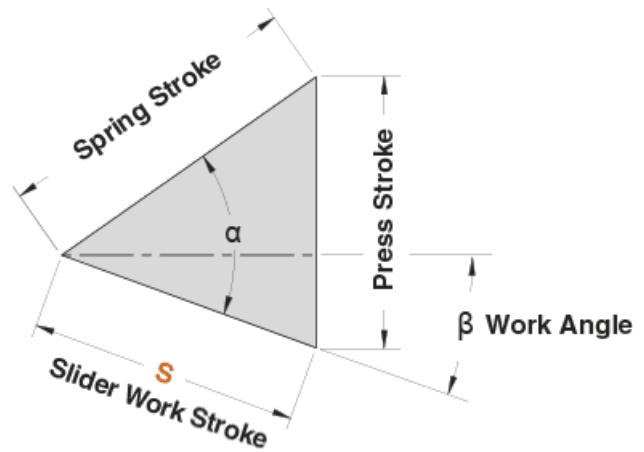

1. CAM DIAGRAM

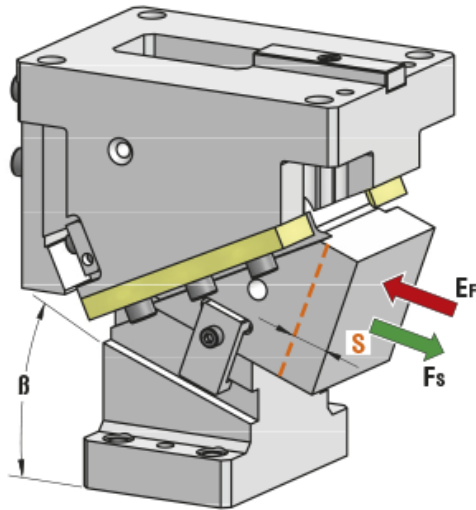

OMCR CODE	Work Angle β	Slider Work Stroke S (mm)	Press Stroke (mm)	Spring Stroke (mm)	$\alpha - \beta$	α
CLK100.00	0°	28,28	28,28	40	45°	45°
CLK100.05	5°	28,39	30,76	40	45°	50°
CLK100.10	10°	33,27	28,72	40	35°	45°
CLK100.15	15°	33,92	31,72	40	35°	50°
CLK100.20	20°	30,86	24,08	32	25°	45°
CLK100.25	25°	32,00	27,05	32	25°	50°
CLK100.30	30°	33,46	24,49	30	15°	45°
CLK100.35	35°	35,38	28,06	30	15°	50°
CLK100.40	40°	39,01	27,69	30	5°	45°
CLK100.45	45°	42,26	32,50	30	5°	50°
CLK100.50	50°	46,67	35,75	30	0°	50°
CLK100.55	55°	52,30	42,84	30	0°	55°
CLK100.60	60°	60,00	51,96	30	0°	60°
CLK100.65	65°	47,32	42,89	20	0°	65°
CLK100.70	70°	58,48	54,95	20	0°	70°



2. WORK FORCE DISTRIBUTION (kN) FOR 1 MILLION CYCLES

The following diagrams illustrate the maximum possible ranges of camforce applicable in several portions of the work area but always working in the exact direction of slider work stroke. If several forces are applied simultaneously on the work area, their common center has to be specified and compared with the tabular infos. The sum of all forces has to be lower than the corresponding tabular value.



Max Work Force with shoulder



Max Work Force with fitting keys

Assembly with shoulder

		WIDTH		
		30	40	30
HEIGHT	40	21	69	21
	40	24	96	24
	40	12	48	12

Assembly with fitting keys

		WIDTH		
		30	40	30
HEIGHT	40	10	34	10
	40	11	48	11
	40	5	24	5