

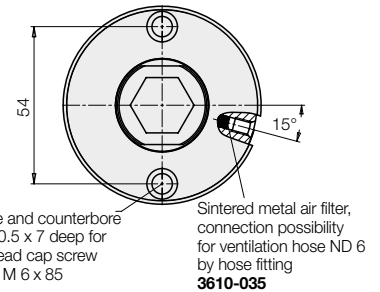

**Work Supports**

**Extending hydraulically – contact by spring force, single acting with spring return, max. operating pressure 500 bar**

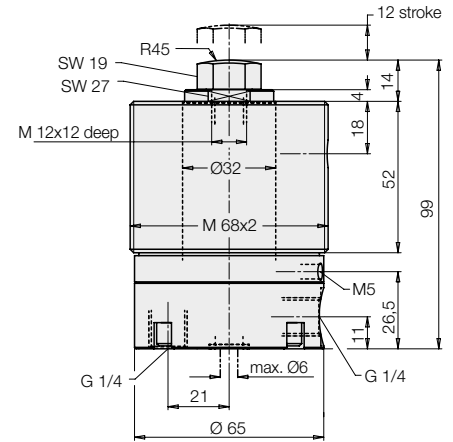
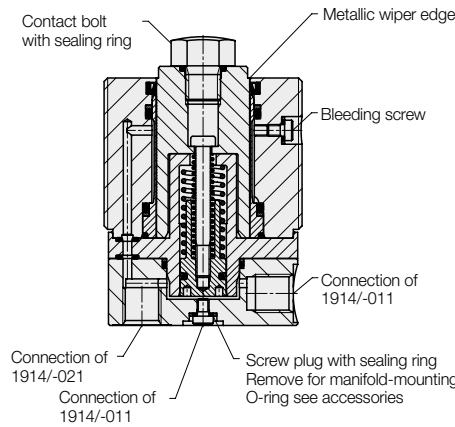

**Application**

Hydraulic work supports are used to provide a self-adjusting rest for the workpiece during the machining operations. They compensate the workpiece surface irregularities, also deflection and vibration under machining loads.

**Description**

The support plunger is retracted in off-position. When pressurised, the support plunger moves against the inserted workpiece by means of spring force. With increasing oil pressure, the support plunger locks hydraulically. After the system has been unclamped, the support plunger returns to the off-position.

The support plunger is provided with female thread to enable the use of threaded pieces for height adjustment.

Oil supply can alternatively be effected from the side or from below.

The internal part of the work support is protected against dust and swarf by a sintered metal air filter.

**Important notes!**

If there is any danger of fluids being sucked into the filter, a vent hose has to be connected.

Spring force should not be used to lift workpieces.

Contact bolts and extensions with large weight can influence the functions of this component.

Work supports are not suitable to compensate side loads.

Work supports must only be operated with a sealed contact bolt.

In dry machining applications, with minimum quantity lubrication or in case of accumulation of very small swarf, there can be a swarf holdup in the area of the metallic wiper edge.

Remedy: Regular cleaning.

Operating conditions, tolerances and other data see data sheet A 0.100.

**Admissible load F as a function of the operating pressure p**

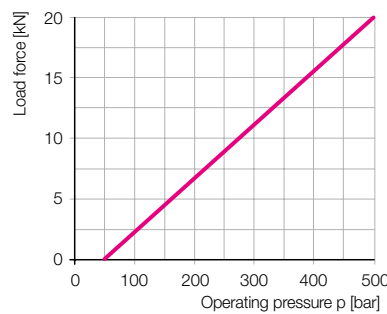

**Installation examples 1914-011**

Oil supply of version 1914-011 can optionally be effected by lateral pipe connection or from below through a drilled channel in the fixture base plate. For this purpose, the screw plug with sealing ring is removed, an O-ring 10x2 is inserted and the lateral connection is closed with the screw plug G1/4.

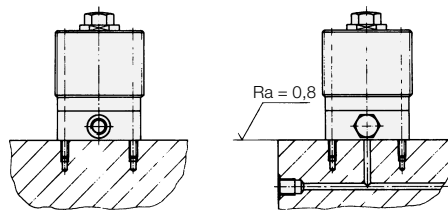

**Installation examples 1914-021**

Oil supply of version 1914-021 is effected by a pipe connection at the bottom. The lateral pipe connection is closed with a sealing plug.

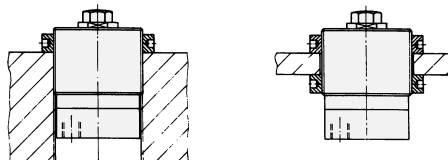

Bolt Ø	[mm]	32
Plunger stroke	[mm]	12
Plunger contact force	[N]	30-60
Oil volume / stroke	[cm <sup>3</sup> ]	2.5
<b>Max. flow rate</b>	[cm <sup>3</sup> /s]	35
Recom. minimum pressure	[bar]	100
Elastic deformation with load and 500bar	[µm/kN]	1.3
Weight	[kg]	2.0

	<b>Part no.</b>
<b>Connection at the side</b>	<b>1914-011</b>
<b>Connection at the bottom</b>	<b>1914-021</b>

<b>Accessories:</b>	
<b>O-ring 10 x 2</b>	<b>3000-347</b>
<b>Screw plug G 1/4</b>	<b>3610-264</b>
<b>Capstan nut M 68 x 2</b>	<b>3522-008</b>
<b>Spare sealing ring (for contact bolt)</b>	<b>3000-536</b>
<b>Contact bolt M 12 x 12</b>	<b>3614-028</b>

**Accessory**  
Capstan nut

