

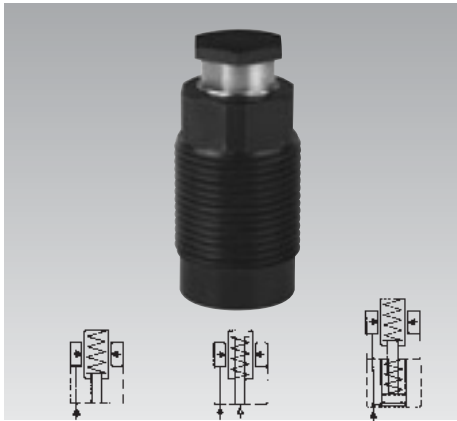

Threaded-Body Work Supports

M 26 x 1.5, with metallic wiper edge, 3 types of function, single acting, max. operating pressure 350 bar



Advantages

- Minimum dimensions
- Minimum distance of the support points 30 mm
- 3 types of function
- Contact force by spring or pneumatically adjustable (1941-900)
- Load force up to 4 kN
- Metallic wiper edge and FKM wiper
- Hardened and sealed contact bolt
- Corrosion-resistant interior parts

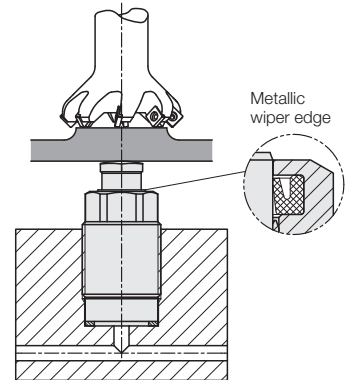

Application

Hydraulic work supports are used to provide a self-adjusting rest for the workpiece during the machining operations. They compensate the workpiece surface irregularities, also vibration and deflection under machining loads.

The threaded-body design allows for space-saving and direct installation into the fixture body. Oil supply is made through drilled channels.

Description

In the body of the threaded-body work support a thin-walled locking bush is integrated, which locks cylindrically around the freely-movable support plunger when pressurising the element with hydraulic oil.

There are three variations of plunger actuation:

1. Spring force
2. Air pressure
3. Oil pressure combined with spring force

The elements are protected against penetration of swarf by a metallic wiper edge and sealed against liquids.

Important notes!

Work supports are not suitable to compensate side loads. The support plunger must not be stressed by tensile load.

The admissible load force is valid for static or dynamic load. Machining forces can generate vibrations, whose amplitude far exceeds an average value, and this can cause yielding of the support plunger. Remedy: increase the safety factor or the number of work supports. In case of accumulation of very small grinding swarf there can be a swarf holdup in the area of the metallic wiper edge. Remedy: regular cleaning in this area.

Work supports must only be operated with a sealed contact bolt. For special versions of contact bolts, we can provide you with a drawing showing the interior contour.

Operating conditions, tolerances and other data see data sheet A 0.100.

Types of function

Spring force

The support plunger is maintained in the retracted position by spring force.

When inserting the workpiece into the fixture, the support plunger is pushed back and contacts the surface to be supported with spring force.

If the workpiece is clamped, the increasing hydraulic pressure locks the support plunger and thus forces in axis direction can be compensated.

After unclamping the support plunger still contacts the workpiece with spring force, until the workpiece will be unloaded from the fixture.

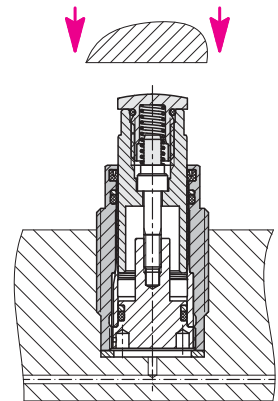

Air pressure

The support plunger is maintained in the retracted position by spring force.

When pneumatically pressurised the support plunger moves against the already clamped workpiece. The contact force can be adjusted by means of a pneumatic pressure reducing valve.

The support plunger will be locked by hydraulic pressure and can compensate forces in axis direction.

For unclamping hydraulic and air pressure will be released and the support plunger retracts by spring force to its off-position.

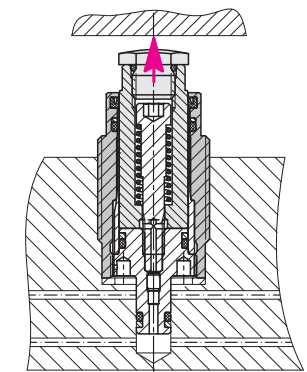

Oil pressure combined with spring force

The support plunger is maintained in the retracted position by spring force.

When hydraulically pressurised the small piston extends and the support plunger contacts the already clamped workpiece with spring force.

The support plunger will be locked by the increasing hydraulic pressure and can compensate forces in axis direction.

For unclamping hydraulic pressure will be released. The small piston retracts by spring force to its off-position and also retracts the support plunger.

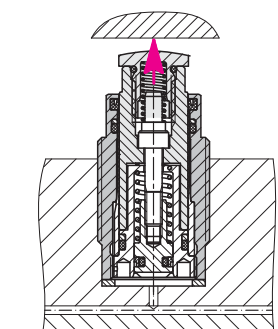

Dimensions

Technical data • Accessories

Spring force

Part no. 1940-900

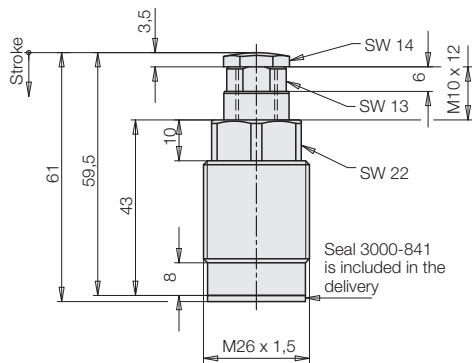

Air pressure

Part no. 1941-900

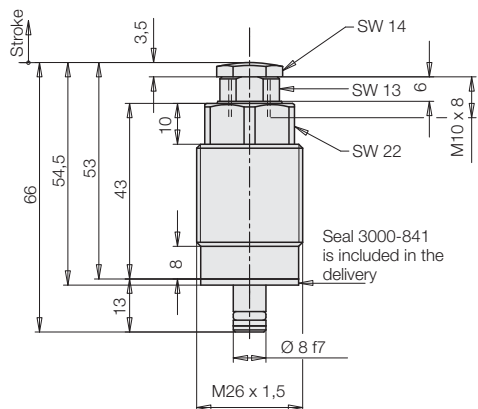

Oil pressure combined with spring force

Part no. 1942-900 Stroke 6.5
1942-925 Stroke 15*

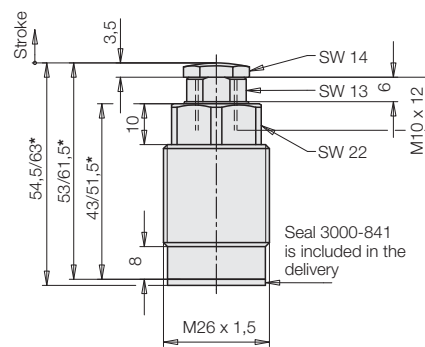

Stroke 6.5 Stroke 15*



Porting details for 1940 and 1942

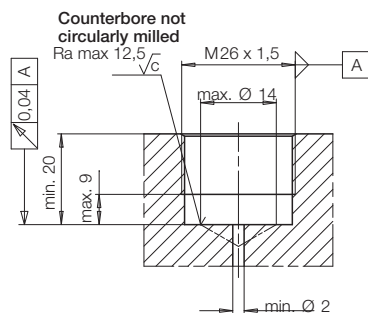

Porting details for 1941

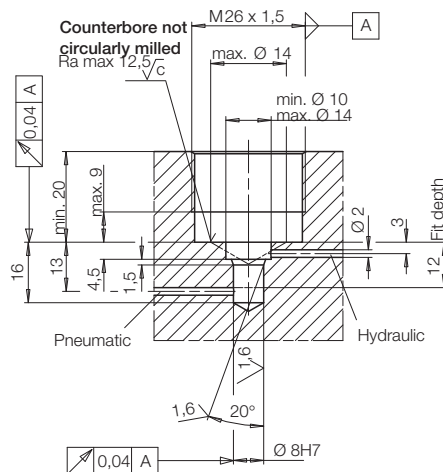

Accessories for 1942-900 and 1942-925

Sharp-edged orifice Ø 0.5

Part no. 3420-395

Technical data

Adm. load force (350 bar)	[kN]	4
Support plunger Ø	[mm]	16
Stroke (1940-900, 1941-900, 1942-900)	[mm]	6.5
(1942-925)	[mm]	15
Springy stroke*	[mm]	6.5
Required oil per stroke (1942-900)	[cm ³]	0.42
(1942-925)	[cm ³]	0.96
Admissible flow rate (1942-9XX)	[cm ³ /s]	25
Max. operating pressure	[bar]	350
Recommended minimum pressure	[bar]	100
Plunger contact force at 1 bar air pressure (1941-900, deduct spring force)	[N]	20
Spring force min./max.	[N]	15/25
Elastic deformation with load and 350 bar	[µm/kN]	3
Max. operating temperature	[°C]	80
Max. seating torque	[Nm]	50
Weight approx.	[kg]	0.2

* In the range of the springy stroke the support plunger contacts the workpiece with spring force.

Admissible load force F as a function of the operating pressure p

