

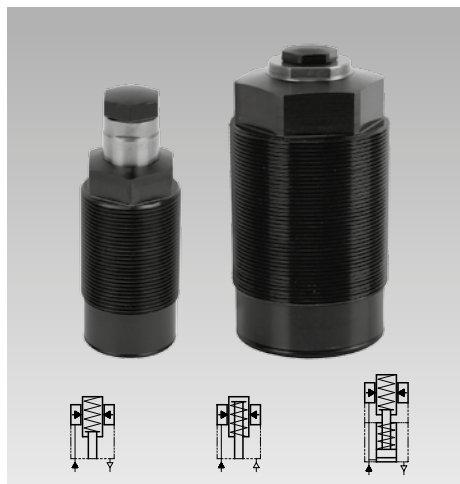

Threaded-Body Work Supports

3 function types, with metallic wiper edge, optional contact control single acting, max. operating pressure 500 bar



Advantages

- Space-saving threaded-body version
- 4 sizes available
- Load force up to 42 kN
- Workpiece contact by spring force or pneumatically adjustable (type 1941)
- Optional pneumatic contact control
- Metallic wiper edge
- Protected FKM wiper
- Inner parts protected against corrosion
- Venting of the spring area
- Connection of positive air pressure protection possible
- Protection cap available as accessory
- Integrated orifice for flow rate limitation (type 1942)
- Mounting position: any

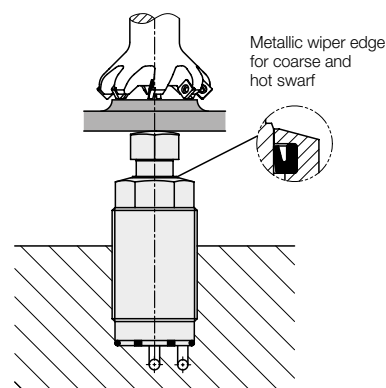

Application

Hydraulic work supports are used to provide a self-adjusting rest for workpieces and avoid their vibration and deflection under machining loads.

The threaded-body design allows for space-saving and direct installation into the fixture body. Hydraulic oil supply and venting are made via drilled channels.

Description

In the body of the threaded-body work supports a thin-walled locking bush is integrated, which locks cylindrically around the freely-movable support plunger when pressurising the element with hydraulic oil.

There are three variations of plunger actuation:

1. Spring force
2. Pneumatically
3. Hydraulically and spring force

The correct contact at the workpiece can be controlled with the optional pneumatic contact control.

The body with metallic wiper edge protects the subjacent FKM wiper against coarse and hot swarf.

Important notes!

Work supports are not suitable to compensate side loads. The support plunger must not be stressed by tensile load.

The admissible load force as per diagram is valid for static and dynamic load.

Machining forces can generate vibrations, whose amplitude exceeds far an average value, and this can cause yielding of the support plunger.

Remedy: Increase the safety factor or the number of work supports.

In dry machining applications, with minimum quantity lubrication or in case of accumulation of very small swarf, there can be a swarf holdup in the area of the metallic wiper edge.

Remedy: Regular cleaning or mount protection cap (see page 2).

Operating conditions, tolerances and other data see data sheet A 0.100.

Installation and connecting possibilities

Drilled channels

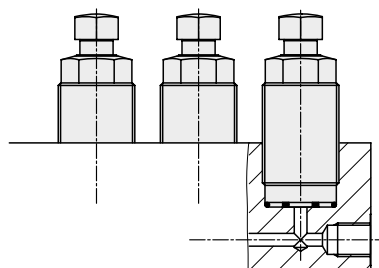

Function

Description on page 2 and page 5.

Venting port

To guarantee safe functioning, a vent port is imperative. It is important that no liquids can penetrate into the venting system.

Positive air pressure connection

By connecting a slight overpressure of max. 0.2 bar, the venting system is effectively protected against the penetration of liquids.

Pneumatic contact control

Description see page 5.

Combination with clamping elements

With this combination, clamping and machining forces will add up:

$$\begin{aligned}
 & \text{clamping force} \\
 & + \text{max. machining force} \\
 & = \text{minimum support force} \times \text{safety factor}
 \end{aligned}$$

Rough calculation from practice:

Required support force $\geq 2 \times$ clamping force

To increase the safety, a support force as high as possible should be achieved

- by using a larger work support
- or
- by using the max. operating pressure of 500 bar by installing a little intensifier (e.g. data sheet D 8.756), in the supply line of the work supports

Example type 1940-XXX

Support plunger in off-position extended

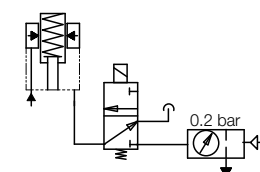
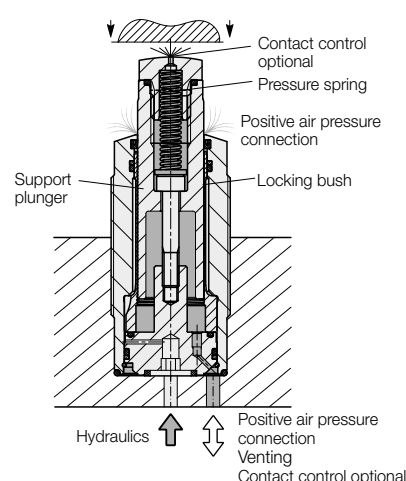

Important note

The positive air pressure must be free of oil and water.

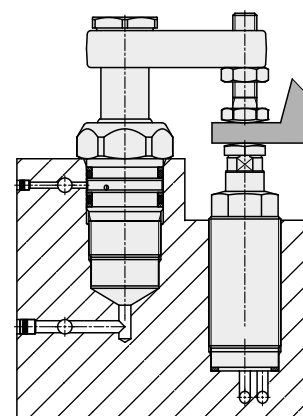

Spring force
Part no. 1940-XXX

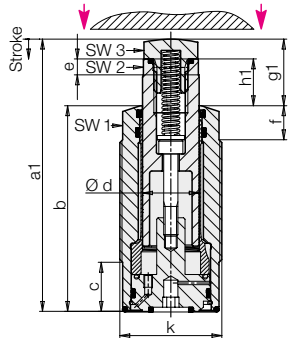

Off-position:
Support plunger extended
Contact by spring force

When inserting the workpiece, the support plunger is pushed back, the spring force has to be overcome (see page 4).

The support plunger will be locked by hydraulic pressure and can compensate forces in axis direction.

After unclamping, the support plunger still contacts the workpiece with spring force, until the workpiece will be unloaded from the fixture.

Pneumatically
Part no. 1941-XXX

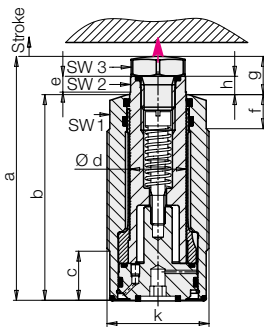

Off-position:
Support plunger retracted
Extend and contact with air pressure

The support plunger contacts the workpiece by air pressure. The contact force is proportional to the air pressure less spring return force (see page 4).

The support plunger will be locked by hydraulic pressure and can compensate forces in axis direction.

For retraction, hydraulic and air pressure will be released and the support plunger retracts by spring force to its off-position.

Hydraulically and spring force
Part no. 1942-XXX

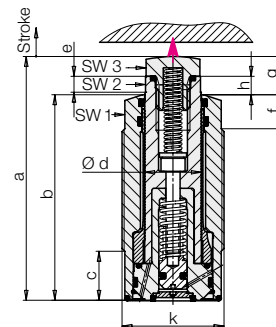

Off-position:
Support plunger retracted
Extend with hydraulics
Contact by spring force

The support plunger is extended by a hydraulically pressurised small piston and contacts the workpiece with spring force.

The support plunger will be locked by increasing hydraulic pressure and can compensate forces in axis direction.

For retraction, the hydraulic pressure will be released. The small piston retracts by spring force to its off-position and also retracts the support plunger.

Porting details

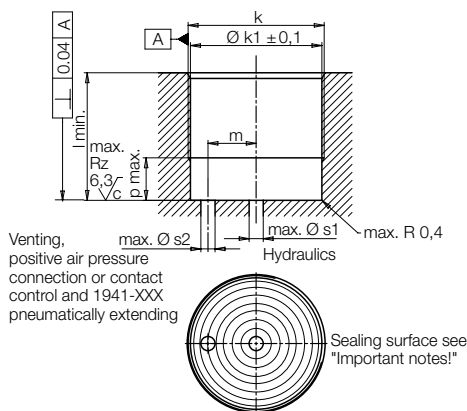

Adm. load force F as a function of the operating pressure p

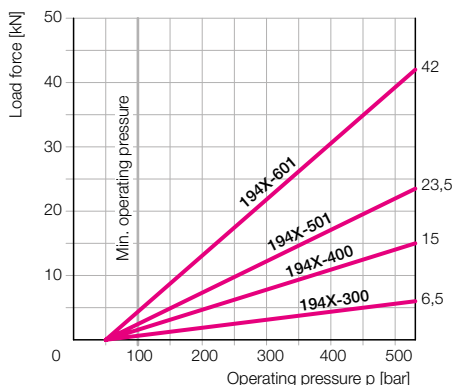

Protection cap (accessories)

The protection cap is fixed by means of the standard contact bolt to the support plunger. It shall be used above all, if a strong coolant jet is directed onto the support plunger or the wiper edge.

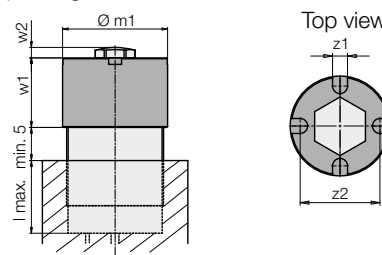

Important notes!

Machining

The code letter c in the surface finish symbol for the sealing surface stands for a concentric groove direction (see drawing), that is given in case of a lowered sealing surface.

In the case of circularly milled surfaces leakages can occur, since the grooves run at right angle to the sealing surface.

Pay attention when mounting:

The location hole must be dry and oil-free to ensure that no liquids penetrate into the spring area of the work supports.

When exchanging work supports:

To get a dry location hole, the hydraulic oil in drilled channels must be removed.

Elastic deformation with load force F and operating pressure 500 bar

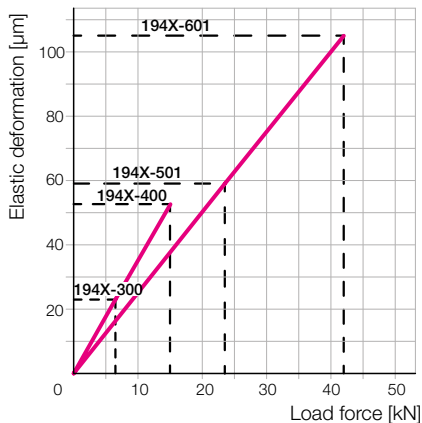

Required dimensions for self-made contact bolts

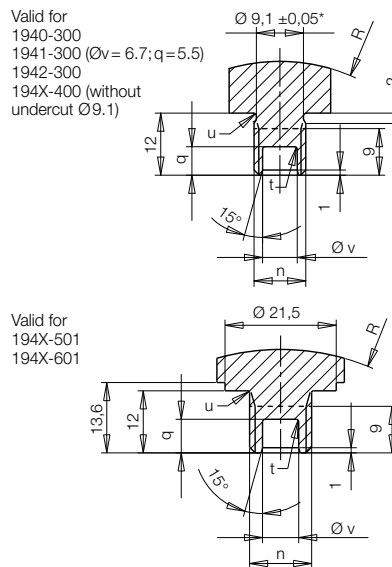

Contact bolt for contact control

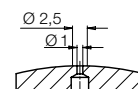

Technical data Accessories • Dimensions

Adm. load force (500 bar)	[kN]	6.5	15	23.5	42
Support plunger Ød	[mm]	16	20	28	32
Stroke	[mm]	8 15	10	10	16
Recommended minimum pressure	[bar]	100	100	100	100
Type					
1940 Spring contact force min./max.	[N]	10/13	–	14/25	22/35
Recommended pressure for positive air pressure connection	[bar]	0.2	–	0.2	0.2
1941 Pneumatic contact force at 1 bar minus spring return force min./max.	[N]	20	–	31.4	61.5
	[N]	24.5/35	–	19/31	22/35
1942 Spring contact force min./max.	[N]	10/13	10/23	14/25	22/35
Spring return force min./max.	[N]	19/39	16/57	30/52	47/69
Max. pressure of positive air pressure connection	[bar]	0.2	0.2	0.2	0.2
Max. return pressure	[bar]	1	1	1	1
Required oil per stroke	[cm ³]	0.5 1	0.8	1.54	3.22
Elastic deformation with load and 500bar operating temperature	[µm/kN]	3.5	3.5	2.5	2.5
Operating temperature	[°C]	0... 70	0... 70	0... 70	0... 70
Tightening torque	[Nm]	60	100	200	400
a	[mm]	75.5 82.5	86	90	115
a1	[mm]	83.5	96	100	131
b	[mm]	59 66	72.5	78	102.5
c	[mm]	8.5	17.5	20.5	20.5
e	[mm]	6	5.6	3	4
f	[mm]	10.5	12	12	18
g	[mm]	16.5	13.5	12	12.5
g1	[mm]	24.5	23.5	22	28.5
h	[mm]	6.5	6.5	4	4.5
h1	[mm]	14.5	16.5	14	20.5
k	[mm]	M30x1.5	M36x1.5	M48x1.5	M60 x 1.5
Øk1	[mm]	28.4	34.4	46.4	58.4
l min.	[mm]	21	35	42	46
l max.	[mm]	37.5	49	53.5	65.5
m	[mm]	10	12	17	22
Øm1	[mm]	35	40	52	65
n	[mm]	M10	M12	M12	M12
p max.	[mm]	8	15	18	18
q	[mm]	19	15	6.5	0
Øs1 max.	[mm]	8	10	14	16
Øs2 max.	[mm]	2	4	5	5
t	[mm]	0.5	0.2	0.5	0
u	[mm]	0.6	0.3	0.3	0.3
Øv	[mm]	6	6.9	7	0
w1	[mm]	28	30	30	43
w2	[mm]	10	7	6.4	6.4
z1	[mm]	5	6	8	8
z2	[mm]	28	32	43	53
R	[mm]	35	45	45	45
SW1	[mm]	24	30	41	50
SW2	[mm]	13	17	22	27
SW3	[mm]	17	19	22	22
Weight, approx.	[kg]	0.32 0.35	0.55	1.0	2.3

Part no.

Contact by spring force	1940-300P	–	1940-400P	1940-501P	1940-601P
Pneumatically extended	1941-300P	–	1941-400P	1941-501P	1941-601P
Hydraulically extended and spring force	1942-300P	1942-305P	1942-400P	1942-501P	1942-601P

P = Option contact control (see also page 5)

Accessories

Protection cap (splash guard)	3546-110	3546-111	3546-112	3546-113
Weight protection cap	[kg]	0.023	0.025	0.032
Contact bolt for contact control	3614-390	3614-389	3614-391	3614-418

Contact forces on the workpiece

Spring force Part no. 1940-XXX

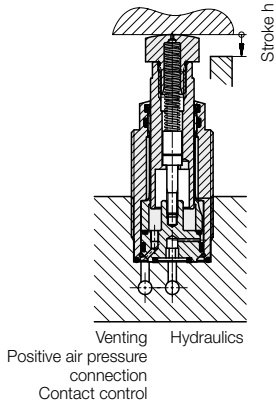

Spring contact force F_{F0} as a function of the stroke of the support plunger h

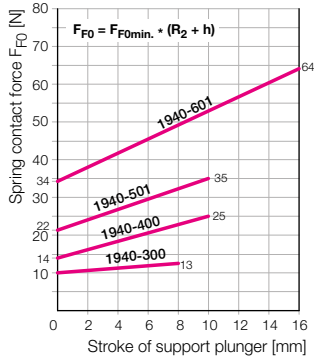

Pneumatic contact forces (F_S, F_P) as a function of the air pressures (p_S, p_A)

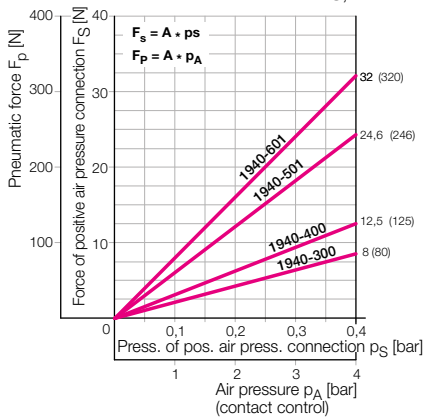

Constant	300	400	501	601
$F_{F0min.}$	10	14	22	34
R_2	0.364	1.103	1.34	1.82
A	20.1	31.4	61.5	80
Weight force*				
Support plunger [N]	0.5	1.3	2.5	3.9
Protection cap [N]	0.23	0.25	0.32	0.62

* For vertical installation: top [-], down [+]. See examples.

Example Work support 1940-300
Protection cap 3546-110
Vertical upward installation
Pres. of pos. air pres. con. 0.2 bar
Stroke of support plunger h = 4 mm

spring force $F_{F0} = F_{F0min.} + (R_2 * h)$
 $F_{F0} = 10 + (0.364 * 4) = 11.45$ N

+force of pos. air pres. con. $F_S = A * p_S = 20.1 * 0.2 = 4.02$ N

- weight force support plunger = 0.50 N

- weight force protection cap = 0.23 N

contact force = 14.74 N

Pneumatically Part no. 1941-XXX

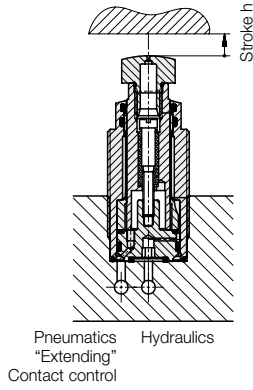

Pneumatic contact force F_P as a function of the air pressure p_A

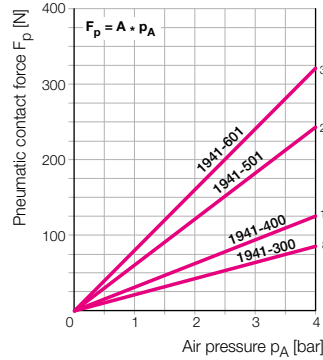

Spring return force F_R as a function of the stroke of the support plunger h

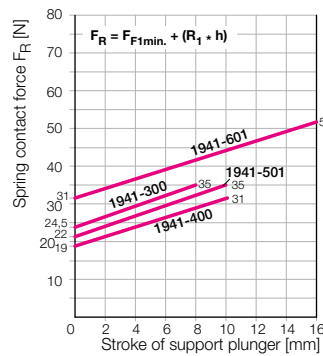

Constant	300	400	501	601
$F_{F1min.}$	24	19	22	31
R_1	1.34	1.26	1.26	1.3
A	20.1	31.4	61.5	80
Weight force*				
Support plunger [N]	0.5	1.3	2.5	3.9
Protection cap [N]	0.23	0.25	0.32	0.62

Example Work support 1941-501
Vertical upward installation
Air pressure 1.5 bar
Stroke of support plunger h = 7 mm

pneumatic force $F_P = A * p_A = 61.5 * 1.5 = 92.25$ N

- spring return force F_R

$F_R = F_{F1min.} + (R_1 * h) = 22 + (1.26 * 7) = 30.82$ N

- weight force support plunger = 2.50 N

contact force = 58.93 N

Spring force Part no. 1942-XXX

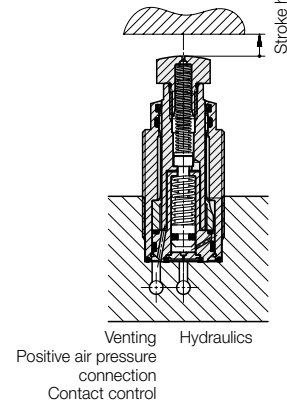

Spring contact force F_{F2} as a function of the stroke of the support plunger h

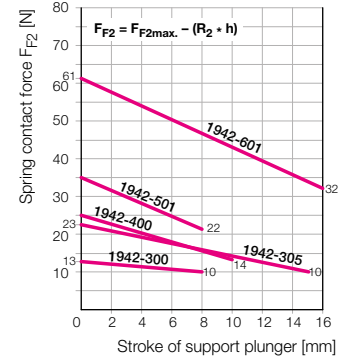

Pneumatic contact forces (F_S, F_P) as a function of the air pressures (p_S, p_A)

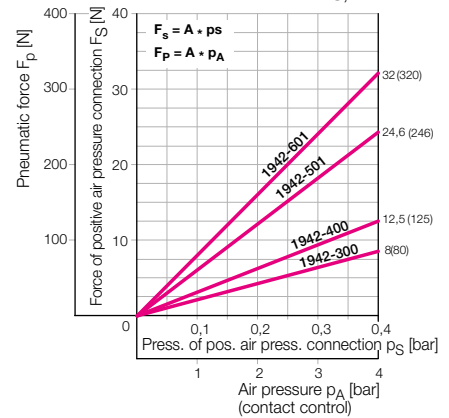

Constant	300	305	400	501	601
$F_{F2max.}$	13	23	25	35	61
R_2	0.364	0.875	1.103	1.34	1.82
A	20.1	20.1	31.4	61.5	80
Weight force*					
Sup. plunger [N]	0.5	0.6	1.3	2.5	3.9
Prot. cap [N]	0.23	0.23	0.25	0.32	0.62

Example Work support 1942-400P
Vertical upward installation
Contact control 2 bar
Stroke of support plunger h = 4 mm

spring force $F_{F2} = F_{F2max.} - (R_2 * h) = 25 - (1.103 * 4) = 20.58$ N

+ pneumatic contact force F_P

$F_P = A * p_A = 31.4 * 2 = 62.80$ N

- weight force support plunger = 1.30 N

contact force = 82.08 N

Pneumatic contact control

Function sequence • Signal conversion

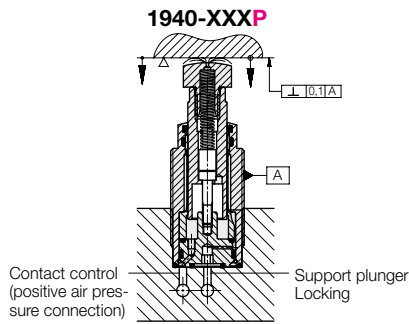

Off-position:

Support plunger extended with spring force. Positive air pressure connection of 0.2 bar switched on, if required.

Function sequence

Workpiece loading and clamping on fixed points.

Switch on contact control

After the message "support plungers are in contact" Hydraulic clamping of support plungers.

Machining of the workpiece

Switch off contact control or reduce pressure of positive air pressure connection to 0,2 bar.

Alternative

Leave the contact control continuously switched on. Advantage:

Acts as a positive air pressure connection.

Disadvantages:

Higher contact force of support plunger

Signals workpiece contact before the workpiece is clamped to fixed points.

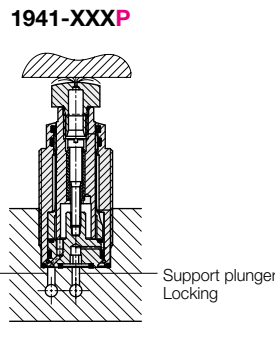

Off-position:

Support plunger retracted with spring force. Positive air pressure connection of 0.2 bar switched on, if required.

Function sequence

Workpiece loading and clamping on fixed points.

Switch on pneumatic pressure to extend and contact control

Support plungers move pneumatically against the workpiece

After the message "support plungers are in contact" Hydraulic clamping of support plungers.

Machining of the workpiece

Switch off contact control or reduce pressure of positive air pressure connection to 0,2 bar.

Important note!

Before unclamping, switch off pneumatic pressure and contact control or reduce pressure of positive air pressure connection to 0.2 bar to allow retraction of the support plunger by spring force.

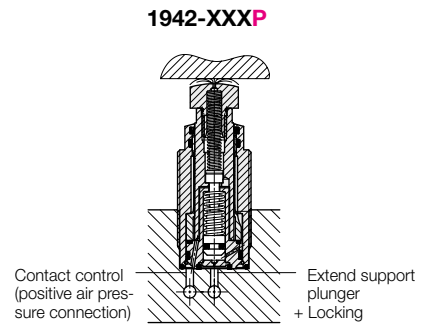

Off-position:

Support plunger retracted with spring force. Positive air pressure connection of 0.2 bar switched on, if required.

Function sequence

Workpiece loading and clamping on fixed points.

Switch on hydraulics for support plunger

Support plungers extend hydraulically, they are in contact with the workpiece by spring force and are hydraulically locked.

Switch on contact control

After the message "support plungers are in contact"

Machining of the workpiece

Switch off contact control or reduce pressure of positive air pressure connection to 0,2 bar.

Important note!

Before unclamping, switch off pneumatic pressure for contact control or reduce pressure of positive air pressure connection to 0.2 bar to allow retraction of the support plunger by spring force.

Limits of application

The pneumatic contact control can only be used if

- the contact surface at the workpiece is square to the axis of the work support.
- the contact surface is machined.
- the air is free of oil and water.

Signal conversion: pneumatic - electric

If the contact bolt is in contact with the workpiece, the little nozzle will be closed.

An electro-pneumatic measuring device can either measure the pressure increase or a drop of the air flow rate.

1. Pressure switch

Advantage

Easy adjustment.

Disadvantage

When contacting the workpiece, the tightness of the nozzle depends on the surface quality of the contact surface and depending on the workpiece more or less large changes in air pressure are possible. With an increasing number of work supports, the pressure differences will decrease and this makes the process-safe setting of a pressure switch more difficult.

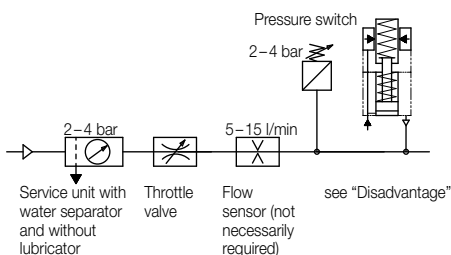

Recommendation

If several work supports have to be controlled, a flow measurement is preferable.

2. Flow meter

The flow meter should have a digital display and at least one adjustable limit switch with a binary output (e.g. type SFAB of FESTO).

Advantages

For the flow measurement, an air pressure of 2 to 4 bar is sufficient so that the support plunger contact force at the workpiece is still relatively low. Simple adjustment of the switching point:

1. Measure the flow rate (Q_{min}) when all support plungers are in contact with the workpiece.
2. Repeat the measurement if 1 support plunger has no contact (Q_{max}).
3. Enter and save switching point = $0.5 \times (Q_{min} + Q_{max})$.

Disadvantages

If the difference ($Q_{max} - Q_{min}$) is too small, increase the flow rate or reduce the number of support points per sensor.

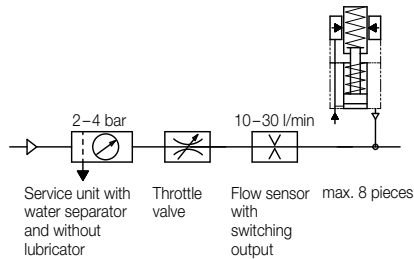

Alternatives

The air gap sensor SOPA from FESTO has an integrated compressed air preparation, as well as two solenoid valves for measuring air and positive air pressure connection.

The device can be expanded to 4 measuring circuits.

Diagram for determination of the switching point

for flow meters with built-in limit switch as a function of the flow rate and the pneumatic pressure.

The curves were determined in the test and apply for the following situation:

"In clamped mode, at least one work support of maximum 8 off is not correctly in contact with the workpiece."

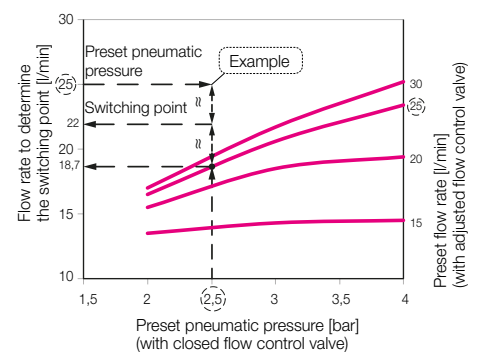

Example Work support 1942-400P
 Preset pneumatic pressure 2.5 bar
 Preset flow rate 25 l/min

As per diagram:

Flow rate, if 1 work support

is not in contact 18.7 thus approx. 19 l/min

Switching point = $0.5 \times (25 + 19) = 22$ l/min

The limit switch at the flow meter is adjusted to 22 l/min.

3. Differential pressure switch

Differential pressure switches (e.g. PEL-System) require only 0.5 to 1.5 bar working pressure.

The exact adjustment of a setting nozzle under practical conditions is required.