



Threaded-Body Work Supports

with metallic wiper edge, shaft length 20 – 100 mm
 single and double acting, max. operating pressure 70 bar



Advantages

- Load force up to 3 kN at 70 bar
- Side load up to 0.3 kN admissible
- Space-saving threaded-body version
- Support in recesses and cavities
- Shaft lengths up to 100 mm available
- High process safety by double-acting function
- Workpiece contact by spring force
- Metallic wiper edge
- Protected FKM wiper
- Inner parts protected against corrosion
- Venting of the spring area
- Connection of positive air pressure protection possible
- Installed orifices for flow rate limitation
- Mounting position: any

Application

Hydraulic work supports are used to provide a self-adjusting rest for workpieces and avoid their vibration and deflection under machining loads.

This series offers high support forces already at 70 bar and can directly be connected to the low-pressure hydraulics of the machine tool. The selectable extension with a shaft diameter of only 16 mm enables the support of surfaces in recesses and cavities that otherwise would be inaccessible.

In case of the double-acting version, the return stroke of the support plunger is effected in a precisely defined time, that is above all advantageous in cycle-dependent installations.

Description

The support plunger is hydraulically extended and retracted by means of a small single or double-acting cylinder. Contact to the workpiece is made by spring force. The pressure spring can be easily exchanged.

The support plunger is additionally guided in the area of the shaft diameter and can therefore absorb side loads up to 300 N.

Important notes

The admissible load force is valid for static or dynamic load. The support plunger must not be stressed by tensile load.

Machining forces can generate vibrations, whose amplitude exceeds far an average value, and this can cause yielding of the support plunger.

Remedy: increase the safety factor or the number of work supports.

Work supports must only be operated with a sealed contact bolt.

In dry machining applications, with minimum quantity lubrication or in case of accumulation of very small swarf, there can be a swarf hold-up in the area of the metallic wiper edge.

Remedy: regular cleaning.

Operating conditions, tolerances and other data see data sheet A 0.100.

Function

The support plunger is retracted in off-position. When pressurised, the piston of the single or double-acting cylinder extends against an internal stop and the support plunger contacts the already clamped workpiece with spring force.

With continuing pressure increase, the conical hydraulic piston moves downwards. The support plunger will be radially locked by the slotted locking bush using a low-friction spherical shell and can then absorb load forces in axis direction.

For unclamping, hydraulic pressure will be released. The conical hydraulic piston is pushed upwards by spring force, whereby the locking of the support plunger disengages.

The single-acting piston retracts the support plunger with spring force to its off-position.

This takes place quicker with the double-acting version.

Venting port

To guarantee safe functioning, a vent port is imperative.

Positive air pressure connection

By connecting a slight overpressure of max. 0.2 bar, the venting system is effectively protected against the penetration of liquids.

Combination with clamping elements

In the above example the machining force is to be added to the clamping force of the compact clamp:

$$\begin{aligned} & \text{clamping force} \\ & + \text{max. machining force} \\ & = \text{minimum support force} \times \text{safety factor} \end{aligned}$$

Rough calculation from practice:

Required support force $\geq 2 \times$ clamping force

To increase the safety, a support force as high as possible should be achieved by

- using a larger work support
- utilising the max. operating pressure
- using a smaller clamping element or reducing the clamping pressure

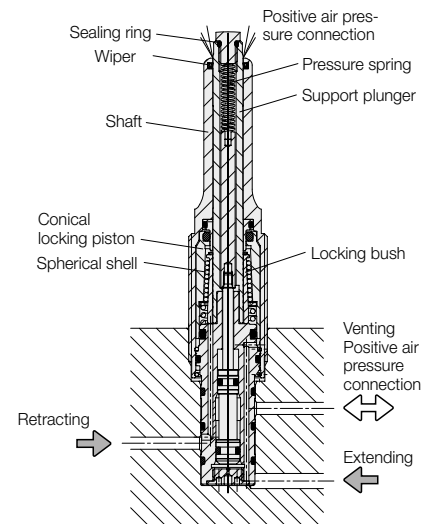
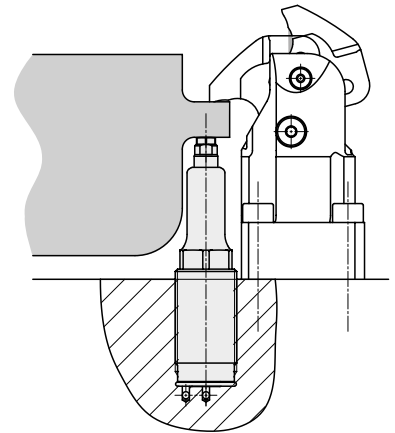

Admissible loads

Max. load force up to 3 kN

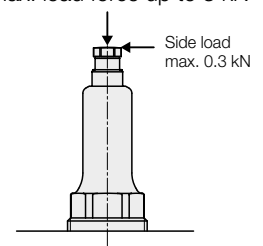

Example

Load of the support plunger by side loads (see diagram on page 3)

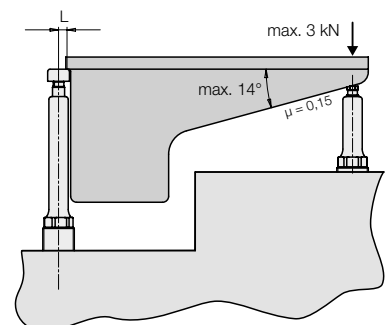

Single acting

Part no. 1947 100 S106 XX0

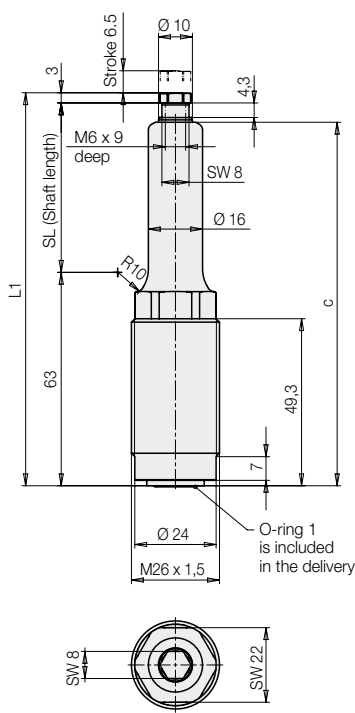

double acting

Part no. 1947 110 S106 XX0

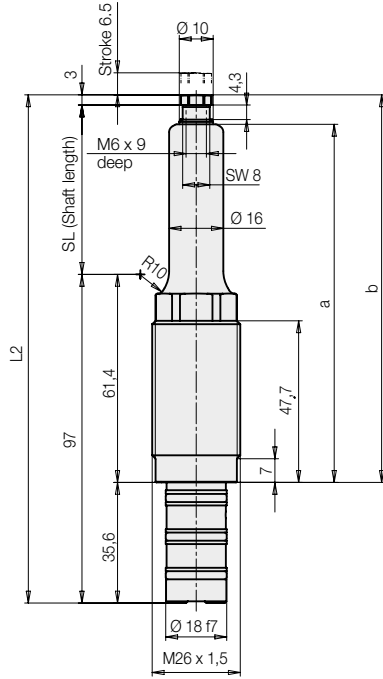

Dimensions for self-made contact bolts

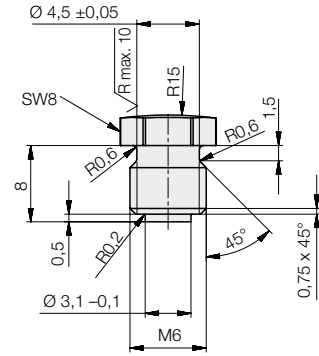

Location holes

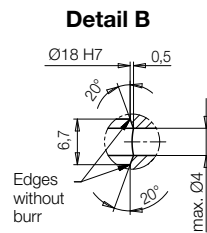
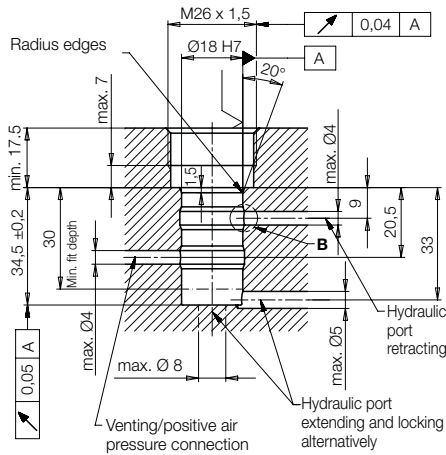
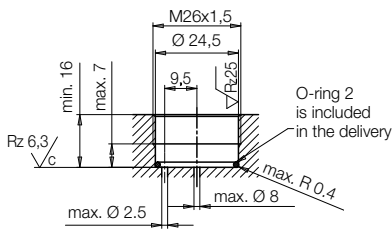

Admissible load F as a function of the operating pressure p

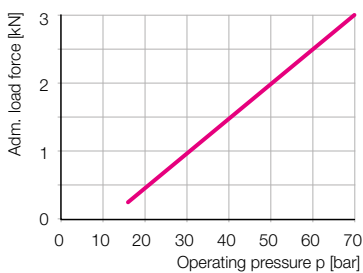
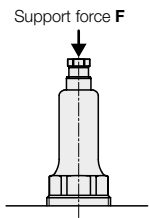

Elastic deformation with load force F and operating pressure 70 bar for shaft lengths 20 – 100 mm

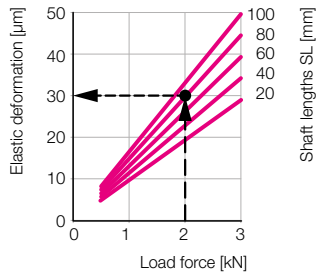
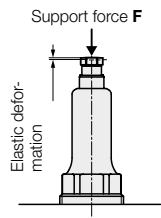

Example

Work support 1947 110S 106 080

Operating pressure p = 70 bar

Load force F = 2 kN

Shaft length SL = 80 mm

As per diagram:

Elastic deformation approx. 30 µm

Technical data

Adm. load force (70bar)			[kN]	3
Load force F at p (bar)			[kN]	$0.053 \times p - 0.68$
Support plunger $\varnothing d$			[mm]	10
Stroke			[mm]	6.5
Oil volume	extending	single acting	[cm ³]	0.6
	extending	double acting	[cm ³]	0.7
	retracting	double acting	[cm ³]	0.07
Recommended minimum pressure			[bar]	25
Max. pressure in return line		single acting	[bar]	1
		double acting	[bar]	2.5
Spring force min./max.			[N]	3.7/9.5
Elastic deformation			[$\mu\text{m}/\text{kN}$]	$\frac{(SL + 31)}{11.7} + 5.33$
Load force F at 70 bar				
Operating temperature			[°C]	0...70
Tightening torque			[Nm]	32
SL (available shaft lengths)			[mm]	20 30 40 50 60 70 80 90 100
L1			[mm]	SL + 66
L2			[mm]	SL + 100
a			[mm]	SL + 55.7
b			[mm]	SL + 64.4
c			[mm]	SL + 57.3

Single acting

Part no. Shaft lengths 20 – 50mm	1947 100S 106 XX0
Weight, approx.	[kg] 0.27 up to 0.32

Double acting

Part no. Shaft lengths 20 – 100mm	1947 110S 106 XX0
Weight, approx.	[kg] 0.32-0.37

Spare parts

O-ring 1 10.82 x 1.78 (single acting)	3001 013
O-ring 2 21.95 x 1.78 (single acting)	3002 170
Seal kit, external seals (double acting)	0132 927

XX0 = Shaft length SL in mm.

Example of ordering: Threaded-body work support
double acting
selected shaft length **60 mm**
Part no. 1947 110S 106 060

Elastic bending f at the admissible side load of 0.3 kN and an operating pressure of 70 bar as a function of the shaft length SL

Max. load force up to 3 kN

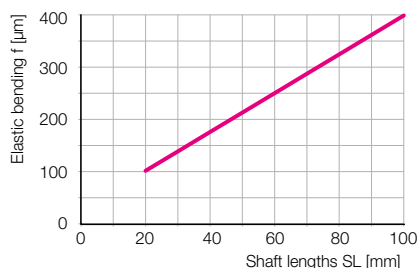
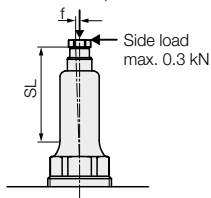

Adm. load force Fadm at an operating pressure of 70 bar as a function of lever length L and the shaft length SL

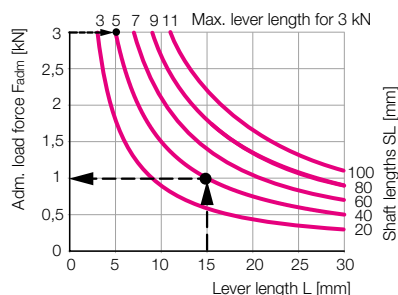
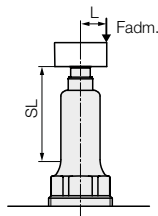

Example

Work support 1947 110S 106 040

Operating pressure $p = 70$ bar
Lever length $L = 15$ mm
Shaft length $SL = 40$ mm

As per diagram:
Adm. load 1 kN

Up to which lever length can the work support absorb the max. side load of 3 kN?

As per diagram: max. lever length 5 mm