



Lifting experience.



## The brands

# Yale®

Yale is the leading brand for standard manual hoisting equipment in Europe. As early as 1877, Yale produced the first spur-gear hand chain hoist incorporating the Weston screw-and-disc type load brake – a design principle which is still used today. In 1936, hoist manufacture started in Velbert with the production of the world renowned PUL-LIFT®.

The product range as well as all new and further developments of Yale in the individual product sectors constantly raise the benchmark for quality, reliability and safety.

The comprehensive range of products includes hoists, balancers, cranes, load hoisting tackles and crane weighers, hydraulic tools, load moving systems, material handling equipment, textile lifting and lashing equipment as well as personal protection equipment.

The prominently yellow products, which are delivered ready for operation, are used world-wide for the most varied industrial and commercial applications.



# PFÄFF

silberblau

Pfaff-silberblau – the name of this company with its long-standing tradition and history of more than 140 years has become the synonym for power, dynamics and safety. Hoists, material handling equipment as well as rope winches and rack and pinion jacks of the Pfaff-silberblau brand are used wherever high loads need to be lifted, turned or moved in an environment with demanding safety requirements.

In logistics, industrial production or outdoor applications, the innovative products and application-specific designs with their unique silver blue finish provide the solution to numerous lifting applications.



## The company

### COLUMBUS McKINNON Industrial Products GmbH

Yale has already been a successful partner within the international corporate network of Columbus McKinnon Corporation (CMCO) for ten years.

Since 2008, Pfaff-silberblau has extended the portfolio of products and services of the company.

Today, the two trademarks of Yale and Pfaff-silberblau are combined under the name of Columbus McKinnon Industrial Products GmbH. As partners, we present a comprehensive range of products whereby each individual product fulfills the wide variety of our customers' requirements with regards to performance, quality and efficiency. Experience, know-how and innovative strength combined with a far-reaching understanding of user requirements is the formula for success on which our portfolio of hoisting and material handling equipment products has been based for a long time. Our tradition of close customer relationships and customer services as well as our constant striving for optimisation provide the basis for all new and further developments of the Yale and Pfaff-silberblau brands.

As a premium supplier of two leading brands, we have set ourselves the target of offering our customers world-wide high-quality hoisting and material handling equipment that is designed for moving, lifting, positioning and securing heavy loads both ergonomically and safely.

Columbus McKinnon Industrial Products GmbH is a subsidiary of Columbus McKinnon Corporation (CMCO), Amherst/USA, one of the world's leading providers of material handling equipment. CMCO has more than 130 years experience in developing and producing cranes, hoists and lifting tackles. Today, the company has more than 2500 employees world-wide.

More information about Columbus McKinnon Industrial Products as well as the brands Yale and Pfaff-silberblau is available on the Internet at [www.cmco.eu](http://www.cmco.eu), [www.yale.de](http://www.yale.de) and [www.pfaff-silberblau.com](http://www.pfaff-silberblau.com)





## Training

We offer many different training seminars in our training centres in Velbert and Kissing. The centres offers not only product training but also seminars providing up-to-date insider information and a consolidated knowledge in the usage of rope, lifting and lashing practices. Modern communication technologies, hands-on experience and well designed training documentation guarantee a quick and lasting training success. As required all training seminars can also be held at other locations. Seminars on special themes on request.

## Training to become a competent person for the inspection of Yale and Pfaff-silberblau hoisting equipment according to UVV BGV D8

According to German laws and standards all hoisting equipment must be subjected to a mandatory inspection at least once a year. The inspection must be performed by a competent person.

In this seminar the participants are trained according to the safety regulations and by hands-on repair to be qualified to perform the safety inspections.

### Target group

Members from all industrial areas who are entrusted with the inspection, service and repair of hoisting equipment.



**Please note our user instructions at the beginning of each chapter.**





## Our service for you:

Qualified personnel as well as specialised dealers provide competent know-how and service. Columbus McKinnon logistics with worldwide distribution allows short lead times and international availability.

### Business hours:

Monday - Thursday 08:00 a.m - 04:00 p.m

Friday 08:00 a.m - 03:00 p.m

### Shipping:

Monday - Thursday 07:00 a.m - 12:00 a.m and

12:30 p.m - 04:00 p.m

Friday 07:00 a.m - 02:00 p.m

## Product documentation

Every unit is supplied with operating instructions, CE declaration of conformity resp. manufactures works test certificate, which confirms the perfect tested status of the product.

Additional documentation, e.g. spare parts manuals or maintenance and repair instructions are available on request or at our homepage [www.cmco.eu](http://www.cmco.eu)



## DIN EN ISO 9001

Columbus McKinnon Industrial Products GmbH manufactures world wide according to uniform, controlled standards of DIN EN ISO 9001.

This is a guarantee for our business partners that given standards in design and development, manufacturing, assembly and service are complied with.



Certified since November 1991



## Special Documentation

Additional inspections with test report 2.2 resp. inspection certificate 3.1.B according to DIN EN 10204, GOST R certificates or specific pre-shipment inspections e.g. by DNV or GL can be carried out at cost on request.

Products



**Hoisting Equipment**

- Ratchet lever hoists
- Hand chain hoists
- Corrosion & Explosion protection
- Trolleys & Trolley clamps
- Electric & Pneumatic chain hoists
- Chains & Accessories
- Manual winches
- Cable puller & Accessories
- Electric & Pneumatic winches
- Rack & Pinion jacks
- Crane systems
- Power supply



**Spring Balancers**

- Spring tensioners
- Spring balancers



**Tigrip® Load Hoisting Tackle**

- Grabs & Clamps
- Permanent load lifting magnets
- Lifting lugs & C-hooks
- Barrel grabs & Crate grabs
- Load hoisting tackle for underground construction
- Clamps & Tine hooks
- Spreader beams
- Crane forks

**Tigrip® Crane Weighers**

- Crane weighers
- Load indicator



**Textile Lifting Slings**

- Round slings
- Round sling assembly
- Webbing slings
- Accessories

**Lashing Systems**

- Lashings
- Special lashings
- Accessories

**Personal Protective Equipment**



**Material Handling Equipment**

- Hand pallet trucks
- Hand pallet trucks with weighing system
- Scissor pallet trucks
- Pallet lift trucks
- Manual drive stackers
- Electric pedestrian stackers
- Elevating platforms, mobile

**Load Moving Systems**





### Hydraulic Jacks & Tools

- Hydraulic cylinders, single-acting
- Hydraulic cylinders, double-acting
- Hydraulic pumps 700 bar & up to 2000 bar
- Foot pump 700 bar
- Electric & Pneumatic motorpumps
- Electric hydraulic power packs
- Hydraulic valves & Accessories
- Hydraulic puller & Jacks
- Hydraulic tools
- Test rig for hoisting equipment
- Workshop presses

### Workshop Equipment

- Jacks
- Workshop presses
- Service jack
- Supporting stand
- Repair sets
- Workshop cranes



Information about products for explosion endangered environments can be found on pages 43-45, Information about corrosion protection can be found on page 42.

## Table of Contents

	Page
Hoisting Equipment	8 - 131
Crane systems & Power supply	132 - 145
<hr/>	
Tigrip®	
Load Hoisting Tackle	146 - 217
Crane Weighers	218 - 221
<hr/>	
Spring Balancers	222 - 229
<hr/>	
Textile Lifting Slings	230 - 249
Lashing Systems	250 - 267
Personal Protective Equipment	268 - 283
<hr/>	
Material Handling Equipment	284 - 331
Load Moving Systems	332 - 337
<hr/>	
Hydraulic Jacks & Tools	338 - 425
<hr/>	
Workshop Equipment	426 - 435
<hr/>	
Index	436 - 437



Hand chain hoists

Electric & Pneumatic chain hoists



Information about products for explosion endangered environments can be found on pages 43-45, Information about corrosion protection can be found on page 42.



Trolleys & Trolley clamps



Manual winches

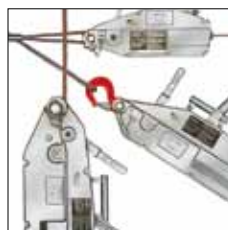

Cable puller & Accessories



Rack & Pinion jacks

**!** Please note our user instructions at the beginning of each chapter.

## Hoisting Equipment

Yale and Pfaff-silberblau hoisting equipment products are reliable and proven equipment renowned world-wide for applications in industry, trade and services.

The comprehensive range includes manual and powered hoisting equipment for a safe lifting and handling of loads ranging from 125 kg to 20000 kg. The products feature a long service life as well as easy and quick maintenance or repair.

Yale and Pfaff-silberblau hoisting equipment products comply with national and international regulations such as the EC Machinery Directive 2006/42/EC and corresponding supplements. In order to meet our high quality standard, the devices are subjected to an overload test in the factory and provided with a test certificate and operating instructions with a declaration of conformity or a manufacturer's declaration.



Electric & Pneumatic winches



Crane systems



Ratchet lever hoists

## Table of Contents

	Page
Ratchet lever hoists	14 - 21
Hand chain hoists	22 - 41
Corrosion & Explosion protection	42 - 45
Trolleys & Trolley clamps	46 - 55
Electric & Pneumatic chain hoists	56 - 77
Chains & Accessories	78 - 79
Manual winches	80 - 91
Cable puller & Accessories	92 - 97
Electric & Pneumatic winches	98 - 121
Rack & Pinion jacks	122 - 131
Crane systems	132 - 143
Power supply	144 - 145



**This user information presents a general review regarding the operation of hoisting equipment and does not substitute the existing operating instructions for the specific hoist product.**

**Lifting operations with hoisting equipment may be carried out by competent users (trained in theory and practice) only.**

**When operated correctly, our hoist products will offer the highest degree of safety in line with long life expectancy and avoid damage to the product and people.**

## Modification of delivery condition

Design and construction of the hoist may not be altered, e.g. by installation of outside supplied parts, bending, welding, grinding, removal of safety relevant components like locking devices, locking pins, safety latches etc.

## Limitations of operation

### Loading

Our hoists have been designed for lifting and transporting of loads. Some models (e.g. ratchet lever hoists) may also be used for pulling and lashing purposes, if admitted in the operating instructions. The indicated capacities refer to loading in straight line and must not be exceeded. Lifting media (e.g. lifting chain or rope) must not be slung over edges and must not be used for the attachment of the load.

### Temperature

Hoists may normally be operated at ambient temperatures between  $-10^{\circ}$  up to  $+50^{\circ}$  C.

These values are approximate and may deviate from the specific givings of the hoist product. The accurate data are given in the current operating instructions. Special models are available on request for higher or lower temperature ranges.

**Attention:** At temperatures below  $0^{\circ}$  C the brake should be checked for freezing. (Check lifting function prior to starting work and refer to "Inspection prior to initial operation").

## Shock loading

The indicated capacities are based on shock-free loading of the hoist. Light bumps as occurred during lifting and lowering as well as transporting of load are admitted. Heavier shock loadings, e.g. falling of the load, are strictly forbidden.

## Chemicals

Hoists and attachments may not be operated without hesitation in the area of chemicals or chemical vapours – consult our specialists for advice. Hoists which have been subject to chemicals or vapours must be taken out of service and inspected by us.

## Transport of people

Transport of people with hoisting equipment is generally forbidden! Transport of people may only be carried out with specially authorized products (e.g. Yaletrac, Mtrac).

## Operation in danger zones

Lifting or transport of loads must be avoided while personnel are in the danger zone.

People are not allowed to pass over or under a suspended load.

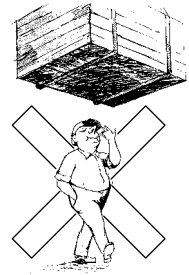

## Electrical hazards

Load carrying hoist components (e.g. load chain) must not be subject to electric current and must never be used as a ground connection during welding. Further electrical hazards, e.g. with powered hoists, are indicated in the specific operating instructions!

Electric connections may only be performed by authorized persons resp. companies.

## Application advices

- Hoists must always be in perfect condition and provided with a legible identity plate.
- Prior to starting work, the hoist including load carrying devices, equipment, supporting structure and suspension must be inspected for obvious deficiencies and failures. In addition, the function of the brake and the correct attachment of hoist and load have to be checked by carrying out a short work cycle of lifting/ pulling or tensioning and releasing.
- Inspect the load chain for sufficient lubrication and visually check for external defects, deformations, superficial cracks, wear or corrosion marks. A defective chain must be replaced prior to operation of the hoist.

- Units equipped with two chain falls should be inspected for twisted or kinked chains prior to being put into operation. The chains of multiple fall hoists may be twisted if the bottom block was turned over.



- Inspect top and bottom hooks for deformations, damage, cracks, wear or corrosion marks. A safety latch must be available and work effectively.
- Hoists with obvious defects and units which have been subject to overload or other dangerous influences have to be taken out of service and may only be operated after test and repair if so required.
- When selecting the proper product, make sure that the hoist is suitable to accept transportation, suspension, type of lashing devices and lashing points safely and without unintended movement (e.g. slipping).

- Load chains must not be used in kinked or knotted condition.

- The load must always be seated in the saddle of the hook. Never attach the load on the tip of the hook. This applies to top and bottom hooks.

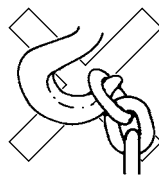

- The operator must ensure that the load is attached in a manner that does not expose himself or other personnel to danger by the hoist, chain(s) or the load.
- During lifting operations the load and suspension hook of the hoist must be perpendicular to the load center to prevent pendle motion of the load.
- The operator may start moving the load only after it has been attached correctly and all personnel are off the danger zone.

- Before lifting make sure that the load can move freely.
- After lifting or tensioning, a load must not be left unattended for a longer period of time.
- Chain stops, slipping clutches etc. are overload protection devices and may not be used as regular load limiters.
- Do not throw the hoist down. Always place it properly on the ground.

## Labelling (Example)

The label contains the following information:

- Rated capacity:** Tragfähigkeit/S.W.L./Capacité 1500kg
- Year of manufacture:** Baujahr/Mfg. Year/Produit en 20\_\_
- Serial or model number:** Ser.Nr./Ser.no. \_\_\_\_\_
- Grade and dimension of load chain:** Lastkette/Load chain/Chaîne 8x24-T(8)
- Lifting height (not mandatory):** Hubhöhe/Lift/Levée \_\_\_\_\_m
- Manufacturer or supplier:** Yale COLUMBUS McKINNON Inc. Products GmbH Am Lindenkamp 31 42699 Völsberg/Germany
- Technical specifications:** SHF: 35daN, STF: 1500daN, EN 12195-3
- CE mark:** CE



## Maintenance and repair

- To ensure safe operation, all hoisting equipment must be subjected to regular inspections according to the maintenance instructions given by the manufacturer.
- Hoists which are due for maintenance (normally once per year, unless adverse working conditions dictate shorter periods) or products with obvious defects may be returned to us for inspection and repair.
- Inspections and tests must be performed by competent persons or specialist workshops that use original spare parts.

## Inspections

- According to German laws and standards all hoisting equipment must be subjected to a mandatory inspection at least once a year. The inspection must be performed by a competent person.
- On building sites hoists have to be inspected every time before operation.
- Hoist and supporting components have to be cleaned prior to inspection. The cleaning procedure must not cause chemical damages (e.g. no acid-embrittlement). Do not expose the hoist and supporting components to unallowed temperatures by e.g. flame cleaning avoid concealment of cracks and excessive material loss (sand blasting).  
We shall be pleased to consult you in this respect. Please submit your hoists for inspection in clean condition. This will reduce inspection costs considerably.

## Criteria for hoist disposal

### Hoists must no longer be operated if e.g.:

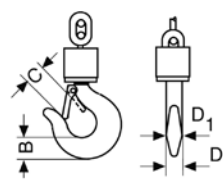
- The identification (identity plate) is missing or illegible.
- Security relevant components like brake, slipping clutch, ratchet pawls etc. do not properly function any longer.
- Housing, control units and suspension of the hoist present obvious deficiencies, i.e.
  - cuts, grooves, cracks
  - excessive corrosion
  - staining due to heat
  - signs of subsequent welding resp. spatters which cannot be easily removed and leave stains.
- Ropes show breakage of wires resp. bruises (criteria for disposal of ropes are given in classification DIN 15020), damages to the rope sleeve and similar failures.
- The load chain presents twisted or distorted links or shows an elongation of 5% of one chain link or a reduction in diameter of more than 10% (average of two measurements (longitudinal and transverse) compared to the nominal diameter).
- The opening (C) of suspension and/or load hooks is stretched by more than 10% compared with the nominal dimension, or if the hook mouth shows a wear of more than 5% of either dimension B or D.
 
- Detrimental impacts by e.g. overloading, shock loading, chemical influences or heat have occurred, the hoist may only be returned to service after careful inspection and repair.



### Ratchet lever hoist with roller chain model C 85

Capacity 750 - 10000 kg

### Ratchet lever hoist with link chain model D 85

Capacity 750 - 10000 kg

Almost unlimited applications in maintenance, mining, construction, steel fabrication, shipbuilding and utility work. Ideal for moving and positioning heavy machines and securing heavy loads, simplifies setting pipes etc. in manholes and trenches.

#### Features

- Enclosed housing with housing cover, handlever and bottom block made from high tensile white malleable cast iron for overall rugged construction.
- The graphite cast iron load sheave for the link chain has precision machined chain pockets for accurate fit and durability of the load chain.
- The roller chain sprocket is made from heat treated chromium-molybdenum steel with precision machined teeth to ensure smooth chain movement.
- Alloyed steel link chain with zinc-plated resp. yellow chromated finish, in accordance with national and international standards and regulations.

#### Options

- All models can be equipped with an overload prevention device in the form of a slip clutch which is factory preset to approx. 25% ± 15% overload.
- Free chaining device to quickly attach the load or to pull the chain through the hoist in both directions.
- Hoist with sling chain.

Since 1936 more than 1 million units have been built in Velbert.



Option:  
Overload protection for  
D95 and C/D85.

This ratchet lever hoist is suitable for cargo tie down applications, since it has an automatic screw-and-disc type load brake preventing an unintentional loosening of the load.



## Technical data model C 85

Model	EAN-No. 4025092*	Capacity kg	Number of chain falls	Chain dimensions d x p Inch	Lift with one full lever turn mm	Handle pull at WLL daN	Weight at standard lift (1.5 m) kg
PUL-LIFT C 85 750	*050173	750	1	5/8" x 3/8"	115	38	8.7
PUL-LIFT C 85 1500	*050180	1500	1	1" x 1/2"	45	31	17.0
PUL-LIFT C 85 3000	*050197	3000	1	1 1/4" x 5/8"	36	40	22.2
PUL-LIFT C 85 6000	*050203	6000	2	1 1/4" x 5/8"	18	44	38.0
PUL-LIFT C 85 10000	*050326	10000	3	1 1/4" x 5/8"	12	44	67.0

## Dimensions model C 85

Model	PUL-LIFT C 85 750	PUL-LIFT C 85 1500	PUL-LIFT C 85 3000	PUL-LIFT C 85 6000	PUL-LIFT C 85 10000
A min., mm	322	389	403	560	785
B, mm	21	27	35	48	61
C, mm	27	30	34	46	54
D, mm	15	20	25	40	40
D1, mm	17	23	25	40	45
E, mm	443	443	570	570	570
F, mm	112	189	197	197	305
G, mm	56	134	142	142	163
H, mm	56	55	55	55	142
J, mm	142	171	179	218	218
K, mm	39	72	76	76	76
L, mm	103	99	103	142	142

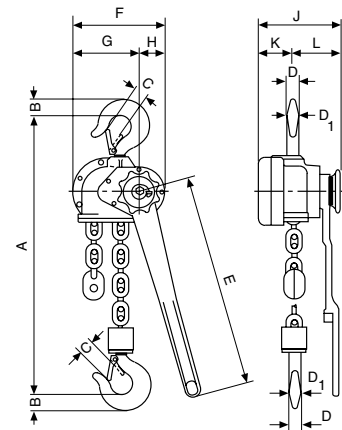

## Technical data model D 85

Model	EAN-No. 4025092*	Capacity kg	Number of chain falls	Chain dimensions d x p mm	Lift with one full lever turn mm	Handle pull at WLL daN	Weight at standard lift (1.5 m) kg
PUL-LIFT D 85 750	*050548	750	1	6 x 18.5	111	38	8.2
PUL-LIFT D 85 1500	*050555	1500	1	9 x 27	45	31	16.3
PUL-LIFT D 85 3000	*050562	3000	1	11 x 31	33	40	19.6
PUL-LIFT D 85 6000	*050579	6000	2	11 x 31	17	42	32.9
PUL-LIFT D 85 10000	*050784	10000	3	11 x 31	11	37	60.0

## Dimensions model D 85

Model	PUL-LIFT D 85 750	PUL-LIFT D 85 1500	PUL-LIFT D 85 3000	PUL-LIFT D 85 6000	PUL-LIFT D 85 10000
A min., mm	322	389	403	532	805
B, mm	21	27	35	48	61
C, mm	27	30	34	46	54
D, mm	15	20	25	40	40
D1, mm	17	23	25	40	45
E, mm	443	443	570	570	570
F, mm	112	189	197	197	305
G, mm	56	134	142	142	163
H, mm	56	55	55	55	142
J, mm	142	171	179	218	218
K, mm	39	72	76	76	76
L, mm	103	99	103	142	142

**!** Yale hoists and trolleys are not designed for passenger elevation applications and must not be used for this purpose.



### Ratchet lever hoist with link chain model D 95

Capacity 1500 - 3000 kg

The D95 in its cast malleable iron design has taken key technical features from the proven D85 but excels due to low tare weight and an extremely small measurement between suspension and load hooks. A versatile unit for moving, positioning and securing loads.

#### Features

- Enclosed housing with housing cover, handlever and bottom block made from high tensile malleable cast iron for overall rugged construction.
- The short handlever is fitted with an ergonomic rubber grip.
- It has an automatically acting load pressure brake which works on the self-locking principal. For example, when used to secure loads an unintentional loosening of the brake is prevented when the load vibrates.
- Standard free chaining device to quickly attach the load or to pull the chain through the hoist in both directions.
- Alloyed steel link chain with zinc-plated resp. yellow chromated finish, in accordance with national and international standards and regulations.

#### Options

- All models can be equipped with an overload prevention device in the form of a slip clutch which is factory preset to approx. 25% ± 15% overload.
- Hoist with sling chain.

- ! This ratchet lever hoist is suitable for cargo tie down applications, since it has an automatic screw-and-disc type load brake preventing an unintentional loosening of the load.



Hoist with sling chain

## Technical data model D95

Model	EAN-No. 4025092*	Capacity kg	Number of chain falls	Chain dimensions d x p mm	Lift with one full lever turn mm	Handle pull at WLL daN	Weight at standard lift (1.5 m) kg
PUL-LIFT D95 1500	*050807	1500	1	6.2x18.5	35	27	9.9
PUL-LIFT D95 3000	*050821	3000	1	9x27.2	38	49	16.5

## Dimensions model D95

Model	PUL-LIFT D95 1500	PUL-LIFT D95 3000
A min., mm	314	376
B, mm	23	30
C, mm	23	25
D, mm	18	22
D1, mm	18	22
E, mm	315	443
F, mm	156	189
G, mm	112	134
H, mm	44	55
J, mm	141	177
K, mm	49.5	72
L, mm	92	105

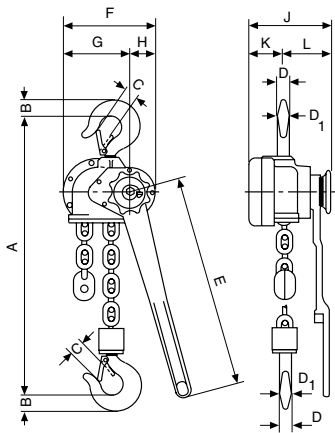

**!** Yale hoists and trolleys are not designed for passenger elevation applications and must not be used for this purpose.



All ratchet lever hoists with a capacity exceeding 750 kg can be used for load attachment according to EN 12195.



## Ratchet lever hoist model AL

Capacity 750 - 3000 kg

Its low tare weight is an advantage. When the hoist has to be frequently carried over longer distances to different assignments. This universal ratchet hoist should not be missing in any service truck.

### Features

- The enclosed housing, hand lever and hand wheel are made from high quality aluminium.
- Low effort on hand lever.
- Due to precise needle bearings the hoist can be operated with little effort.
- Standard free chaining device to quickly attach the load or to pull the chain through the hoist in both directions.
- The chain guide is cast into the body to ensure faultless chain movement.
- Alloyed steel link chain with zinc-plated resp. yellow chromated finish, in accordance with national and international standards and regulations.

### Option

- Stainless steel load chains.

Yale hoists and trolleys are not designed for passenger elevation applications and must not be used for this purpose.

## Technical data model AL

Model	EAN-No. 4025092*	Capacity kg	Number of chain falls	Chain dimensions d x p mm	Lift with one full lever turn mm	Handle pull at WLL daN	Weight at standard lift (1.5 m) kg
AL 750	*051194	750	1	6.3x19.1	30	16	6.4
AL 1000	*051200	1000	1	6.3x19.1	30	22	6.6
AL 1500	*051217	1500	1	7.1x21.2	16	18	10.0
AL 3000	*051224	3000	1	10x30.2	14	28	18.0

## Dimensions model AL

Model	AL 750	AL 1000	AL 1500	AL 3000
A min., mm	315	325	380	455
B, mm	20	23	27	36
C, mm	22	23	26	33
D, mm	14	16	20	24
E, mm	300	300	300	400
F, mm	106	109	138	168
G, mm	47	47	60	75
H, mm	59	62	78	93
J, mm	154	154	177	212
K, mm	49	49	74	94
L, mm	105	105	103	118

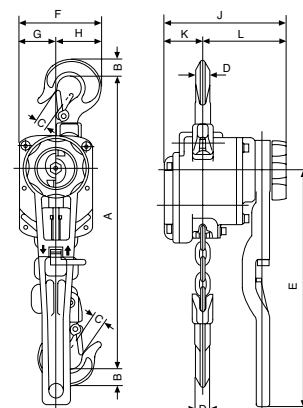

## Ratchet lever hoist model PT

Capacity 800 - 6300 kg

Ratchet lever hoists model PT features improved techniques and ergonomical styling. The advantages of the predecessor range have been maintained and further optimized.

A good, versatile, all round ratchet lever hoist for demanding conditions.

### Features

- The proven stamped steel housing provides extremely low weight without limiting the reliability and sturdiness of the unit.
- The short handlever is fitted with an ergonomic rubber grip.
- Standard free chaining device to quickly attach the load or to pull the chain through the hoist in both directions.
- Alloyed steel link chain with zinc-plated resp. yellow chromated finish, in accordance with national and international standards and regulations.
- Drop forged suspension and load hooks are made from non-aging, high tensile steel and fitted with robust safety latches.

### Options

- All models can be equipped with an overload prevention device in the form of a slip clutch which is factory preset to approx. 25% ± 15% overload.



Option:  
Overload prevention device

**All ratchet lever hoists with a capacity exceeding 750 kg can be used for load attachment according to EN 12195.**

### Technical data model PT

Model	EAN-No. 4025092*	Capacity kg	Number of chain falls	Chain dimensions d x p mm	Lift with one full lever turn mm	Handle pull at WLL daN	Weight at standard lift (1.5 m) kg
PT 800	*076463	800	1	5.6x17.1	24	26	5.5
PT 1600	*076470	1600	1	7.1x21.2	23	30	9.6
PT 3200	*076487	3200	1	9x27.2	16	38	16.0
PT 6300	*076494	6300	2	9x27.2	8	39	31.0

### Dimensions model PT

Model	PT 800	PT 1600	PT 3200	PT 6300
A min., mm	290	330	430	580
B, mm	21	27	36	53
C, mm	24	31	35	46
D, mm	13	20	24	43
E, mm	235	370	370	370
F, mm	120	138	177	259
G, mm	38	41	53	85
H, mm	82	97	124	174
J, mm	142	163	185	185
K, mm	52	65	83	83
L, mm	90	98	102	102

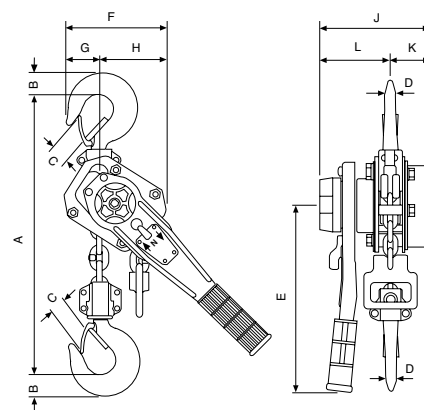





## Ratchet lever hoist model UNOplus

Capacity 750 - 6000 kg

Further technical development turns the ratchet lever hoist into the successor of our proven UNO model. The versatile tool for lifting, pulling and securing of loads is characterised by its compact design and robust stamped steel construction.

### Features

- Due to optimized gearing and improved bearings in the housing cover a minimum effort is required to operate the short hand lever.
- Steel hand wheel as standard.
- Automatic screw-and-disc type load brake with corrosion protected components.
- Standard free chaining device to quickly attach the load or to pull the chain through the hoist in both directions.
- Robust chain guide rollers eliminate fouling and jamming of chain on the load sheave.
- Sturdy bottom block with encapsulated bolt connections
- Alloyed steel link chain with zinc-plated resp. yellow chromated finish, in accordance with national and international standards and regulations.
- Drop forged suspension and load hooks are made from non-aging, high tensile steel and fitted with robust safety latches.

### Option

- Stainless steel load chains.

All ratchet lever hoists with a capacity exceeding 750 kg can be used for load attachment according to EN 12195.



Protection classification

Ex I M2,

Ex II 2 GD c IIB T4 T 120° C X

### Technical data model UNOplus

Model	EAN-No. 4025092*	Capacity kg	Number of chain falls	Chain dimensions d x p mm	Lift with one full lever turn mm	Handle pull at WLL daN	Weight at standard lift (1.5 m) kg
UNOplus 750	*168342	750	1	6x18	20	20	7.2
UNOplus 1500	*168359	1500	1	8x24	22	35	12.5
UNOplus 3000	*168366	3000	1	10x30	17	40	21.5
UNOplus 6000	*168380	6000	2	10x30	9	40	32.0

### Dimensions model UNOplus

Model	UNOplus 750	UNOplus 1500	UNOplus 3000	UNOplus 6000
A min., mm	340	410	510	690
B, mm	22	28	36	45
C, mm	26	32	40	44
D, mm	16	21	27	33
E, mm	250	330	380	380
F, mm	150	170	220	220
G, mm	70	80	100	100
H, mm	80	90	120	120
J, mm	150	180	210	210
K, mm	60	80	90	90
L, mm	90	100	120	120

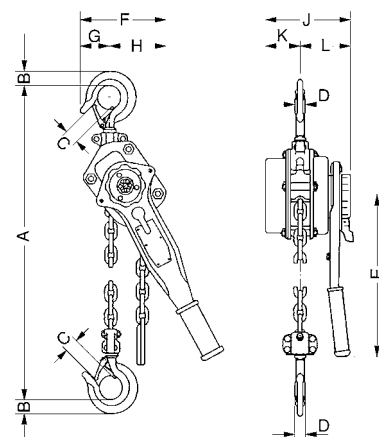

## Ratchet lever hoist model Yalehandy

Capacity 250 - 500 kg

The extreme low tare weight and the very compact design make the hoist easy to use even in confined working conditions. Due to the multitude of application possibilities e.g. in industry, trade and service this ratchet lever hoist is indispensable.

### Features

- The enclosed design protects the internal parts from contamination.
- The short handle lever is fitted with an ergonomic rubber grip.
- All parts of the disc type load brake are manufactured from high quality materials and are corrosion protected.
- Standard free chaining device to quickly attach the load or to pull the chain through the hoist in both directions.
- Alloyed steel link chain with zinc-plated resp. yellow chromated finish, in accordance with national and international standards and regulations.
- Drop forged suspension and load hooks are made from non-aging, high tensile steel and fitted with robust safety latches.



**!** Yale hoists and trolleys are not designed for passenger elevation applications and must not be used for this purpose.

### Technical data model Yalehandy

Model	EAN-No. 4025092*	Capacity  kg	Number of chain falls	Chain dimensions d x p mm	Lift with one full lever turn mm	Handle pull at WLL daN	Weight at standard lift (1.5 m) kg
Yalehandy 250	*075039	250	1	4x12	80	25	2.2
Yalehandy 500	*077675	500	1	4x12	40	25	2.8

### Dimensions model Yalehandy

Model	Yalehandy 250	Yalehandy 500
A min., mm	240	282
B, mm	20	17
C, mm	21	24
D, mm	14	12
E, mm	160	160
F, mm	72	104
G, mm	33	38
H, mm	39	66
J, mm	98	116
K, mm	21	36
L, mm	77	80

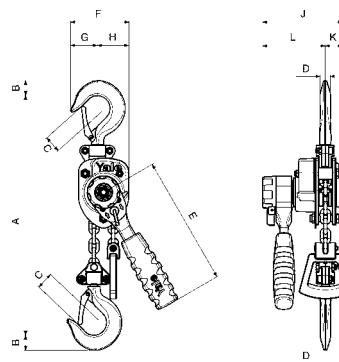

## Hand chain hoist model Yalelift 360

Capacity 500 - 20000 kg

Areas of operation as well as operator conditions have been improved far beyond those of a classical hand chain hoist.

### Features

- The enclosed robust stamped steel housing protects all internal components even in the toughest conditions.
- The extremely low headroom allows maximum use of the lifting height.
- The revolutionary 360° rotating hand chain guide allows the operator to work from virtually any position, in confined spaces or above the load. The Yalelift can even be operated from the side of the load which also makes it possible to use the hoist for horizontal pulling or tensioning. Due to the additional flexibility, the operator is no longer forced to work in the danger zone near the load.
- The brake system is extremely quiet and guarantees operational safety and improved serviceability due to omission of the vulnerable ratchet pawls. All parts are made of high quality materials, additionally zinc-plated or yellow-chromated to increase corrosion prevention.
- Chain guide and gearbox are almost totally enclosed. Even under the toughest conditions the internal gearbox remains protected.
- The hardened load sheave with four precision machined pockets ensures accurate movement of the load chain.
- The surface protected zinc-plated alloy steel load chains fulfil all requirements of current national and international standards and regulations.
- Drop forged load and suspension hooks that yield under overload instead of breaking, are made of high tensile steel. The hooks are fitted with robust safety latches and rotate 360°.

### Options

- Adjustable overload prevention device.
- Stainless steel load and hand chains.
- Chain container
- Corrosion resistant version
- Explosion protection



*Patented!  
Rotating hand  
chain guide*



### Protection classification

- II 2 GD c IIB T4 T 125° C X,
- II 2 GD c IIB T3 T 145° C



Chain guide



High quality encapsulated ball bearings and sliding bushes for smooth and effortless operation.

**!** Easy modification from Yalelift 360 to Yalelift IT is possible.

## Hand chain hoist model Yalelift 360 20t

Capacity 20000 kg

The brake system used in the Yalelift series is also employed in the Yalelift 360 20t, setting standards in terms of operational safety and serviceability. The brake is extremely quiet and wear resistant. In spite of its high capacity, the Yalelift 360 20t features a compact design.

### Features

- All components are made of high quality materials, some components are zinc-plated or yellow-chromated for added corrosion protection. This ensures that also heaviest loads are held reliably.
- The enclosed robust stamped steel body resists in the toughest conditions and allows outside operation.
- The hardened load sheave with five precision machined pockets ensures accurate movement of the load chain.
- The low headroom (hook-to-hook dimension 1010 mm) allows maximum use of the lifting height.
- The Yalelift 360 20t is equipped with six chain falls only which results in higher speed and lower weight.

### Options

- Adjustable overload prevention device.
- Chain container
- Corrosion resistant version
- Explosion protection



The robust stamped steel housing with four stay bolts is resistant to the toughest working conditions.



The precisely machined load sheave ensures accurate movement of the load chain.



**!** Yale hoists and trolleys are not designed for passenger elevation applications and must not be used for this purpose.

## Technical data model Yalelift

Model	EAN-No. 4025092*	Capacity  kg	Number of chain falls	Chain dimensions d x p mm	Hand chain overhaul for 1 m lift m	Pull on hand chain at WLL daN	Weight at standard lift (3 m) kg
YL 500	*075183	500	1	5x15	30	21	9
YL 1000	*075190	1000	1	6x18	49	30	13
YL 2000	*075206	2000	1	8x24	71	32	20
YL 3000	*075213	3000	1	10x30	87	38	29
YL 5000	*075220	5000	2	10x30	174	34	38
YL 10000	*075237	10000	3	10x30	261	44	71
YL 20000	*080910	20000	6	10x30	522	2x44	196

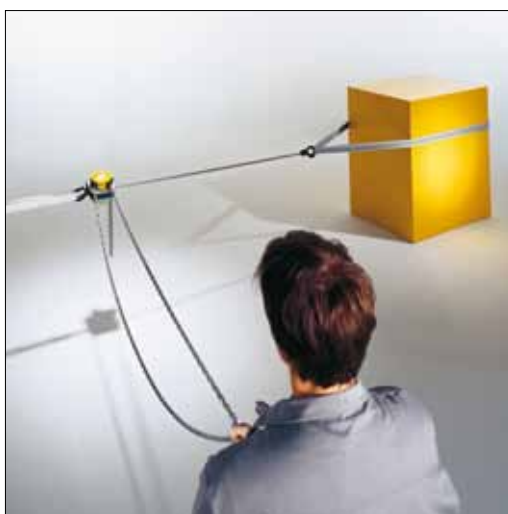



Dimensions model Yalelift

Model	YL 500	YL 1000	YL 2000	YL 3000	YL 5000	YL 10000	YL 20000
A min., mm	300	335	395	520	654	825	1010
B, mm	17	22	30	38	45	68	85
C, mm	24	29	35	40	47	68	64
D, mm	133	156	182	220	220	220	303
E, mm	148	175	203	250	250	383	555
F, mm	148	167	194	219	219	219	250
G, mm	139	164	192	225	242	326	391
H, mm	206	242	283	335	352	436	501
I, mm	24	24	31	34	21	136	-
K, mm	61	70	83	95	95	95	396
L, mm	87	97	111	124	124	124	125
M, mm	110	125	156	178	285	401	471
N, mm	14	19	22	30	37	50	56

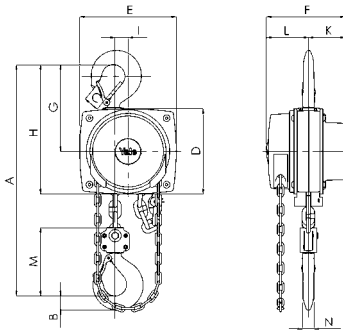

Model Yalelift 360, 500 - 3000 kg, single fall

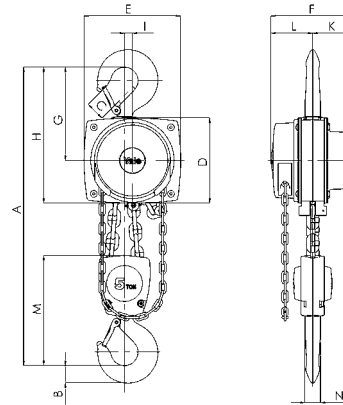

Model Yalelift 360, 5000 kg, double fall

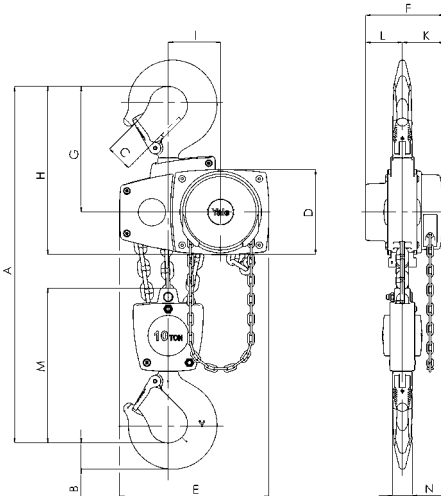

Model Yalelift 360, 10000 kg, three fall

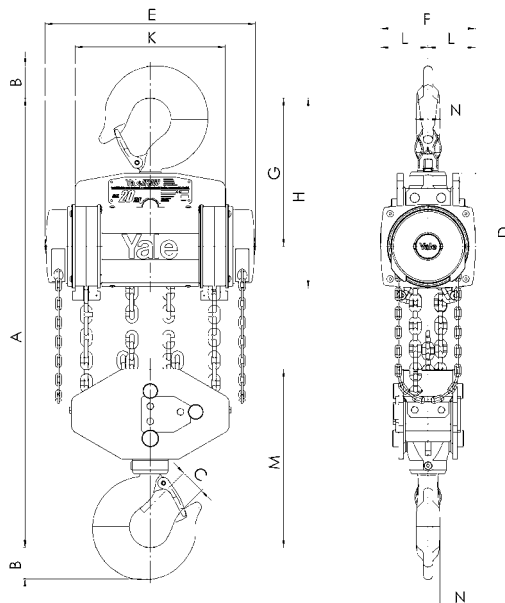

Model Yalelift 360, 20000 kg, six fall



## Hand chain hoist model Towerlift

Capacity 1000 - 2000 kg

The Towerlift is the inverted version of the Yalelift 360 and specifically designed for operation on traversing tower systems.

### Features

- The unit is provided with a special chain guide and a totally enclosed housing.
- The basic version of the Towerlift offers capacities of 1000 kg and 2000 kg.
- Black powder coat finish as standard.
- Alloyed steel link chain with zinc-plated resp. yellow chromated finish, in accordance with national and international standards and regulations.

### Options

- Adjustable overload prevention device.
- Chain container

**! Different colours, capacities and lifting heights are available on request.**

## Technical data model Towerlift

Model	EAN-No. 4025092*	Capacity kg	Number of chain falls	Chain dimensions d x p mm	Hand chain overhaul for 1 m lift m	Pull on hand chain at WLL daN	Weight at standard lift (3 m) kg
Towerlift 1000	*079815	1000	1	6x18	49	30	14
Towerlift 2000	*079822	2000	1	8x24	71	32	21

## Dimensions model Towerlift

Model	Towerlift 1000	Towerlift 2000
A min., mm	335	395
B, mm	22	30
C, mm	29	35
D, mm	156	182
E, mm	205	243
F, mm	167	194
G, mm	164	192
H, mm	242	283
I, mm	24	31
K, mm	70	83
L, mm	97	111
M, mm	125	156
N, mm	19	22

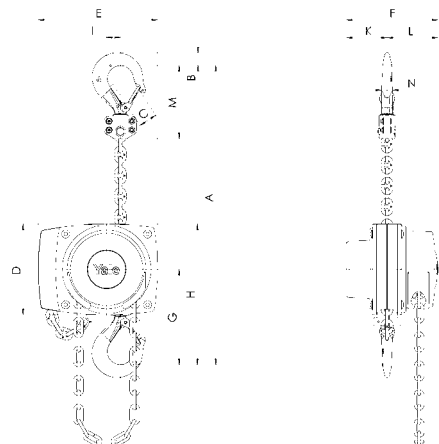

## Hand chain hoist model Towerlift ES

Capacity 1000 kg

The Towerlift ES is a further development of the Towerlift. Like the Towerlift the model ES is provided with a chain reeving system specifically designed for the stage/entertainment industry. This allows operation in standard hoist configuration as well as in inverted mode.

### Features

- The hoist comes with revolving chain container which can be fully used in standard hoist configuration as well as in inverted mode.
- Black powder coat finish.
- The chain container has a maximum capacity for 15 m of chain.

### Option

- Adjustable overload prevention device.



**!** Yale hoists and trolleys are not designed for passenger elevation applications and must not be used for this purpose.

### Technical data model Towerlift ES

Model	EAN-No. 4025092*	Capacity kg	Number of chain falls	Chain dimensions d x p mm	Hand chain overhaul for 1 m lift m	Pull on hand chain at WLL daN	Weight at standard lift (3 m) kg
Towerlift ES	*079495	1000	1	6 x 18	49	30	15

### Dimensions model Towerlift ES

Model	Towerlift ES 1000
A min., mm	335
B, mm	22
C, mm	29
D, mm	213
E, mm	232
F, mm	212
G, mm	164
H, mm	299
I, mm	24
K, mm	88
L, mm	124
M, mm	125
N, mm	19
O, mm	335
P, mm	593
S, mm	455

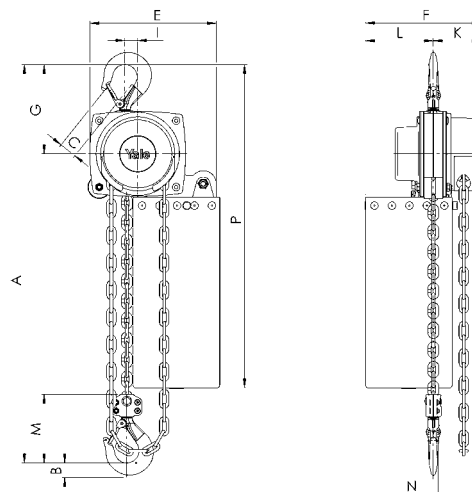

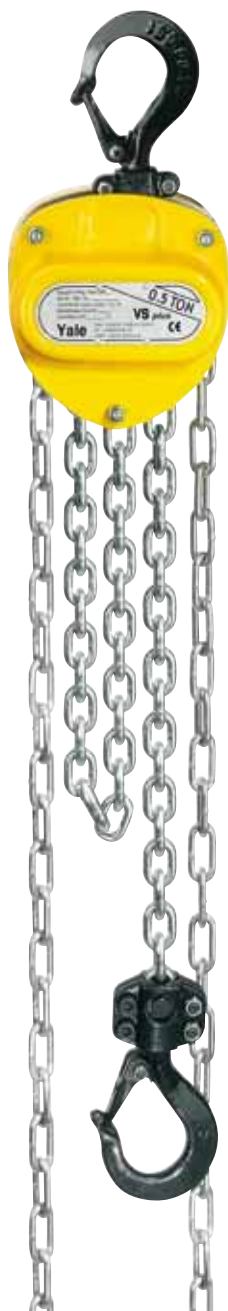

### Hand chain hoist model VSplus

Capacity 500 - 5000 kg

The Yale hand chain hoist VSplus is through further technical development the successor of our proven VS model. We set standards with the extremely robust all-steel construction and high quality bearings for drive pinion, load chain sheave and gearbox. A maximum of corrosion prevention and maintenance friendliness are special features of this model.

#### Features

- 4 strong bolts between the side plates and the reinforced housing covers ensure increased stability.
- Precision machined guide rollers ensure smooth running of the load chain.
- Encapsulated, life-time lubricated bearings ensure a long service life.
- Brake system protected against the ingress of dust, foreign particles and corrosion.
- Reinforced hand wheel cover with stiffening strips in conjunction with steel through going studs further increase hoist stability.
- Zinc-plated load chain as standard for added corrosion protection.

#### Options

- Overload prevention device.
- Chain container
- Stainless steel load and hand chains.



**Yale hoists and trolleys are not designed for passenger elevation applications and must not be used for this purpose.**

## Technical data model VSplus

Model	EAN-No. 4025092*	Capacity in kg/ number of chain falls	Chain dimensions d x p mm	Hand chain overhaul for 1 m lift m	Pull on hand chain at WLL daN	Weight at standard lift (3 m) kg
VSplus 0,5/1	*078832	500/1	6 x 18	28	26	9.0
VSplus 1,0/1	*078726	1000/1	6 x 18	42	36	11.2
VSplus 2,0/1	*079358	2000/1	8 x 24	54	54	18.0
VSplus 2,0/2	*079136	2000/2	6 x 18	84	37	15.3
VSplus 3,0/1	*079372	3000/1	10 x 30	83	52	28.0
VSplus 3,0/2	*079129	3000/2	8 x 24	108	41	24.7
VSplus 5,0/2	*079341	5000/2	10 x 30	165	44	38.7

## Dimensions model VSplus

Model	VSplus 0,5/1	VSplus 1,0/1	VSplus 2,0/1	VSplus 2,0/2	VSplus 3,0/1	VSplus 3,0/2	VSplus 5,0/2
A min., mm	320	370	450	530	530	620	620
A1, mm	455	484	576	491	644	596	644
B, mm	17	15	33	31	38	41	48
C, mm	29	30	33	34	38	37	43
D, mm	11	15	23	24	27	24	33
F, mm	125	147	183	147	215	183	215
F1, mm	213	232	314	232	333	314	333
J, mm	115	125	142	125	163	142	163
J1, mm	146	153	174	153	179	174	179
K, mm	51	57	68	57	79	68	79
L, mm	64	68	74	68	84	74	84
M, mm	195	224	266	231	316	286	334
N, mm	260	260	310	260	310	310	310
O, mm	140	140	200	140	200	200	200
P, mm	110	110	130	110	130	130	130

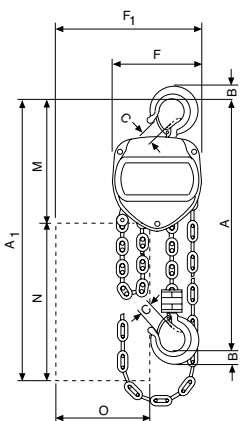

Model VSplus, 500 - 3000 kg, single fall

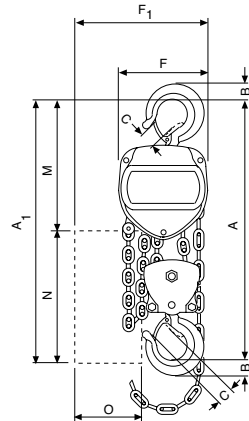
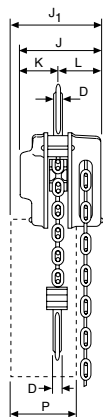

Model VSplus, 2000 - 5000 kg, double fall

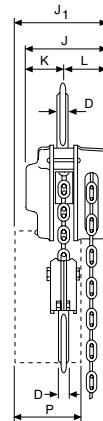

Option: Chain container





### Hand chain hoist model Compact

Capacity 500 - 5000 kg

The Compact is designed and built for quality and safe, efficient operation. The arrangement of the spur gear drive allows a compact unit with very small dimensions. A lightweight hoist with low maintenance – and at economical price.

#### Features

- Low headroom permits optimal usage of available space.
- Two guide rollers and a heat treated load sheave with 4 precision machined chain pockets ensure smooth operation of the chain.
- The construction prevents a blocking and slipping of the hand chain.
- Roller and ball bearings at all rotating parts reduce friction loss and increase smooth operation and efficiency.
- Zinc-plated load chain as standard for added corrosion protection.
- Drop forged suspension and load hooks are made from non-aging, high tensile steel and fitted with robust safety latches.

## Technical data model Compact

Model	EAN-No. 4025092*	Capacity in kg/ number of chain falls	Chain dimensions d x p mm	Pull on hand chain at WLL daN	Weight at standard lift (3 m) kg
Compact 500	*062053	500/1	6 x 18	26	8.7
Compact 1000	*062060	1000/1	6 x 18	36	10.6
Compact 2000	*062077	2000/2	6 x 18	37	15.0
Compact 3000	*062084	3000/2	8 x 24	41	23.4
Compact 5000	*062091	5000/2	10 x 30	44	37.5

## Dimensions model Compact

Model	Compact 500	Compact 1000	Compact 2000	Compact 3000	Compact 5000
A, mm	289	334	413	524	610
B, mm	16	21	27	35	45
C, mm	22	27	30	37	46
D, mm	120	142	142	178	210
E, mm	120	142	142	178	210
F, mm	106	122	122	139	162

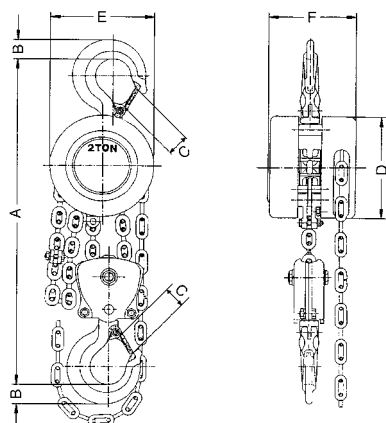

Model Compact, 500 - 5000 kg, double fall

**!** Yale hoists and trolleys are not designed for passenger elevation applications and must not be used for this purpose.



Depicted rubber buffers  
optionally available.

## Hand chain hoist with integrated push or geared type trolley model Yalelift IT

Capacity 500 - 20000 kg

The combination of the Yalelift 360 with a low headroom manual trolley provides even more flexibility in the application of the Yalelift 360.

### Features

- All units of this series up to a capacity of 3000 kg are provided with single chain fall and the min. headroom (Dim. A) has been further reduced. Ideal for applications with low ceilings and limited headroom.
- The proven and almost stepless adjustment system allows quick and easy assembly of the trolley.
- Trolleys up to 5 t are offered for two beam ranges. Range A for a flange width up to 180 mm is standard and covers approx. 80 % of all requirements. Conversion to range B for beam width up to 300 mm can be easily accomplished.
- The trolley wheels are designed for a max. beam profile incline of 14 % (DIN 1025 - part 1), excellent rolling features are guaranteed by prelubricated, encapsulated ball bearings.
- Anti-drop and anti-tilt devices as standard.

### Options

- Adjustable overload prevention device.
- Chain container
- Corrosion resistant version
- Explosion protection
- Beam locking device to secure the unloaded trolley in a fixed position on the beam (park position e.g. on ships). Available up to a capacity of 5000 kg.



#### Protection classification

- Ex II 2 GD c IIB T4 T 125°C X,
- Ex II 2 GD c IIB T3 T 145°C

## Technical data model Yalelift IT

Model	EAN-No. 4025092*	Capacity in kg/ number of chain falls	Size	Beam flange width b	Beam flange thickness t max.	Curve radius min.	Weight at standard lift (3 m) - P	Weight at standard lift (3 m) - G	Weight at standard lift (3 m) with locking device - P	Weight at standard lift (3 m) with locking device - G
				mm	mm	m	kg	kg	kg	kg
YLIT 500	*079006	500/1	A	50 - 180	19	0.9	20	24	26	31
YLIT 500	-	500/1	B	180 - 300	19	0.9	21	25	27	32
YLIT 1000	*079013	1000/1	A	50 - 180	19	0.9	27	32	35	40
YLIT 1000	-	1000/1	B	180 - 300	19	0.9	29	33	37	41
YLIT 2000	*079020	2000/1	A	58 - 180	19	1.15	44	49	52	57
YLIT 2000	-	2000/1	B	180 - 300	19	1.15	46	50	54	58
YLIT 3000	*079037	3000/1	A	74 - 180	27	1.5	77	82	86	91
YLIT 3000	-	3000/1	B	180 - 300	27	1.4	79	84	88	93
YLIT 5000	*079044	5000/2	A	98 - 180	27	2.0	125	130	135	140
YLIT 5000	-	5000/2	B	180 - 300	27	1.8	129	134	139	144
YLIT 10000	*080996	10000/3	B	125 - 310	40	1.8	-	-	-	-
YLIT 20000**	*172325	20000/6	B	180 - 310	40	no radius	-	-	-	-

\*\*Dimensions on request

P in connection with weight = with pushed trolley

G in connection with weight = with geared trolley



Chain guide



High quality encapsulated ball bearings and sliding bushes for smooth and effortless operation.



The robust stamped steel housing with four stay bolts is resistant to the toughest working conditions.



The precisely machined load sheave ensures accurate movement of the load chain.

**!** Yale hoists and trolleys are not designed for passenger elevation applications and must not be used for this purpose.

# Hoisting Equipment Hand chain hoists

## Dimensions model Yalelift IT

Model	YLIT 500	YLIT 1000	YLIT 2000	YLIT 3000	YLIT 5000	YLIT 10000
A min., mm	245	272	323	382	550	784
A1, mm	158	178	205.5	252	260.5	380
A2, mm	-	-	-	-	-	-
B, mm	17	22	30	38	45	68
C, mm	24	29	35	40	47	68
D, mm	14	19	22	30	37	50
F (Geared trolley), mm	92	92	91	107	149.5	113
H1, mm	24.5	24	23.5	32	30.5	55
I (Pushed trolley), mm	71.5	71.5	95.5	131	142.5	169
I (Geared trolley), mm	76.5	76.5	98	132.5	148.5	169
L, mm	270	310	360	445	525	430
L1, mm	130	130	150	180	209	200
L2, mm	159	175	207	256	283	261
L3, mm	-	-	-	-	-	-
L4, mm	-	-	-	-	-	-
M, mm	M 18	M 22	M 27	M 30	M 42	M 48
O, mm	60	60	80	112	125	150
P (Geared trolley), mm	108	110	112	112	117	158
T (Area A), mm	280	290	305	320	364	-
T (Area B), mm	400	410	425	440	484	540

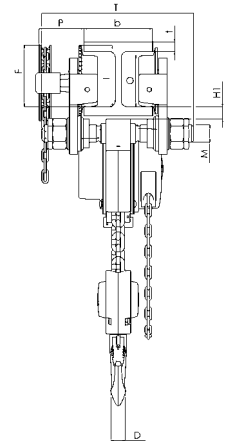
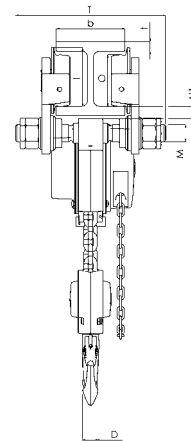
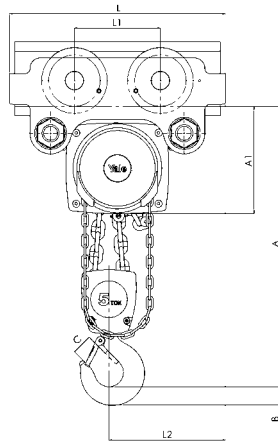
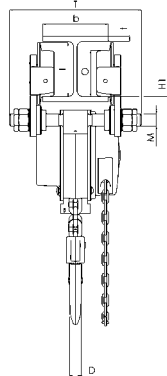
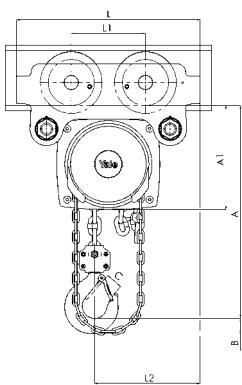

Model Yalelift ITP, 500 - 3000 kg, single fall

Model Yalelift ITP/ITG, 5000 kg, double fall

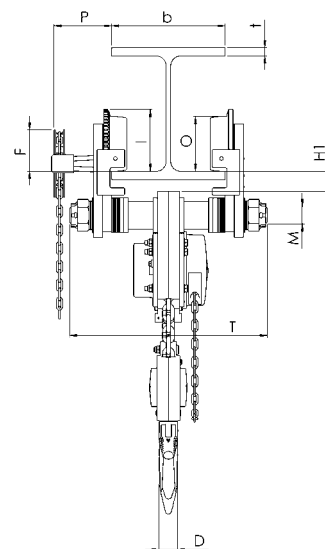
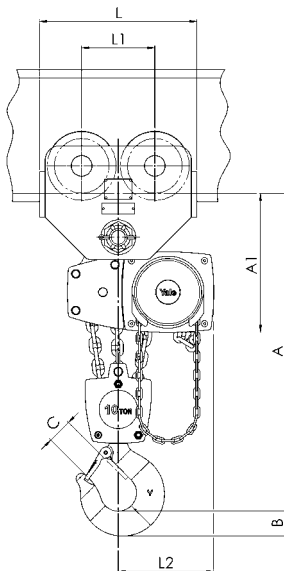
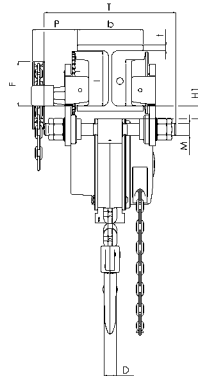
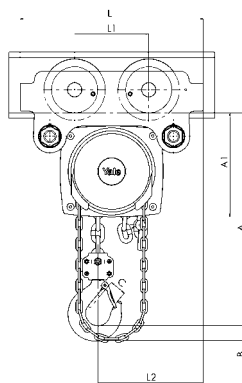

Model Yalelift ITG, 500 - 3000 kg, single fall

Model Yalelift ITG, 10000 kg, three fall



**Hand chain hoist  
with integrated push or geared  
type trolley (low headroom)  
model Yalelift LH**

Capacity 500 - 10000 kg

The hand chain hoist model Yalelift LH with integrated low headroom manual trolley is the consequent further development of the Yalelift IT. Wherever an even smaller headroom is essential, the Yalelift LH is the ideal choice.

**Features**

- The specially developed chain reeving system and chain guide allow the bottom block to be pulled laterally to the hoist even further up and almost against the beam flange.
- The integrated design of the innovative Yalelift LH uses the same manual trolleys as incorporated in the Yalelift IT series.
- All models of the LH series up to 3000 kg capacity are provided with single chain fall.
- The proven and almost stepless adjustment system allows quick and easy assembly of the trolley.
- The trolleys up to 5 t are offered for two beam ranges. Range A for a flange width up to 180 mm is standard and covers approx. 80 % of all requirements. Conversion to range B for beam width up to 300 mm can be easily accomplished.
- The trolley wheels are designed for a max. beam profile incline of 14 % (DIN 1025 - part 1), excellent rolling features are guaranteed by prelubricated, encapsulated ball bearings.
- The low headroom version of the Yalelift IT is adjustable to fit a wide range of beam profiles (e.g. INP, IPE, IPB).
- Anti-drop and anti-tilt devices as standard.
- Excellent rolling features due to machined steel wheels mounted on pre-lubricated, encapsulated ball bearings.

**Options**

- Adjustable overload prevention device.
- Chain container
- Corrosion resistant version
- Explosion protection
- Beam locking device to secure the unloaded trolley in a fixed position on the beam (park position e.g. on ships). Available up to a capacity of 5000 kg.



**Protection classification**

- ⊕ II 2 GD c IIB T4 T 125° C X,
- ⊕ II 2 GD c IIB T3 T 145° C

## Technical data model Yalelift LH

Model	EAN-No. 4025092*	Capacity in kg/ number of chain falls	Size	Beam flange width b	Beam flange thickness t max.	Curve radius min.	Weight at standard lift (3 m) - P	Weight at standard lift (3 m) - G	Weight at standard lift (3 m) with locking device - P	Weight at standard lift (3 m) with locking device - G
				mm	mm	m	kg	kg	kg	kg
YLLH 500	*079501	500/1	A	60 - 180	19	0.9	27	31	33	38
YLLH 500	-	500/1	B	180 - 300	19	0.9	27	32	34	38
YLLH 1000	*079518	1000/1	A	70 - 180	19	0.9	35	40	43	48
YLLH 1000	-	1000/1	B	180 - 300	19	0.9	36	41	44	49
YLLH 2000	*079525	2000/1	A	82 - 180	19	1.15	61	65	69	73
YLLH 2000	-	2000/1	B	180 - 300	19	1.15	62	67	70	75
YLLH 3000	*079532	3000/1	A	100 - 180	19	1.5	107	112	116	121
YLLH 3000	-	3000/1	B	180 - 300	19	1.4	109	114	118	123
YLLH 5000	*079549	5000/2	A	110 - 180	27	2.0	152	157	162	167
YLLH 5000	-	5000/2	B	180 - 300	27	1.8	156	161	166	171
YLLH 10000	-	10000/3	A	125 - 180	40	1.8	on request	230	on request	on request
YLLH 10000	-	10000/3	B	180 - 310	40	1.8	on request	232	on request	on request

P = with pushed trolley  
G = with geared trolley

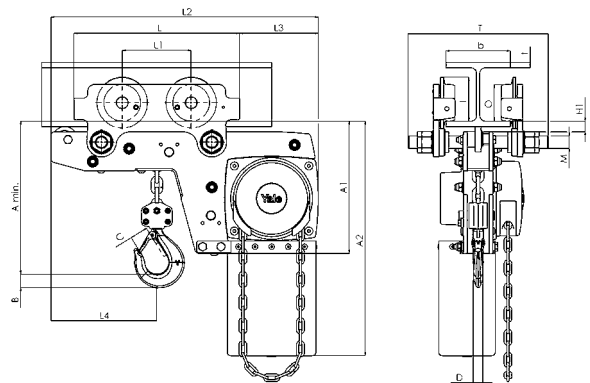

Model Yalelift LHP, 500 - 3000 kg, single fall

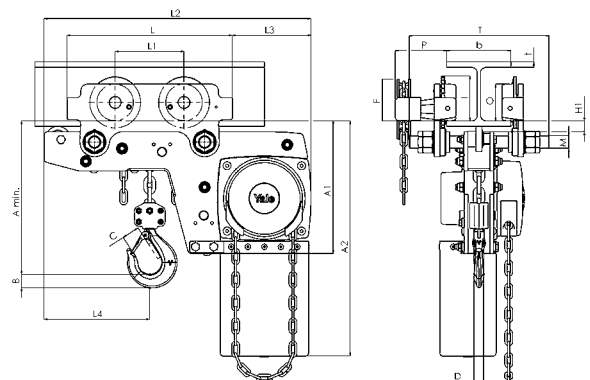

Model Yalelift LHG, 500 - 3000 kg, single fall

**!** Yale hoists and trolleys are not designed for passenger elevation applications and must not be used for this purpose.

## Dimensions model Yalelift LH

Model	YLLH 500	YLLH 1000	YLLH 2000	YLLH 3000	YLLH 5000	YLLH 10000
A min., mm	188	211	264	316	425	565
A1, mm	223	250	289	346	345	365
A2, mm	381	427	511	614	612	665
B, mm	17	22	30	38	45	68
C, mm	24	29	35	40	47	68
D, mm	14	19	22	30	37	50
F (Geared trolley), mm	92	92	91	107	150	150
H1, mm	24	24	24	32	31	45
I (Pushed trolley), mm	72	72	96	131	143	170
I (Geared trolley), mm	77	77	98	133	149	170
L, mm	270	310	360	445	525	485
L1, mm	130	130	150	180	209	225
L2, mm	444	488	582	690	720	805
L3, mm	124	135	172	203	175	215
L4, mm	184	201	230	265	283	348
M, mm	M 18	M 22	M 27	M 30	M 42	M 48
O, mm	60	60	80	112	125	150
P (Geared trolley), mm	108	110	112	112	117	165
T (Area A), mm	280	290	305	320	364	440
T (Area B), mm	400	410	425	440	484	540

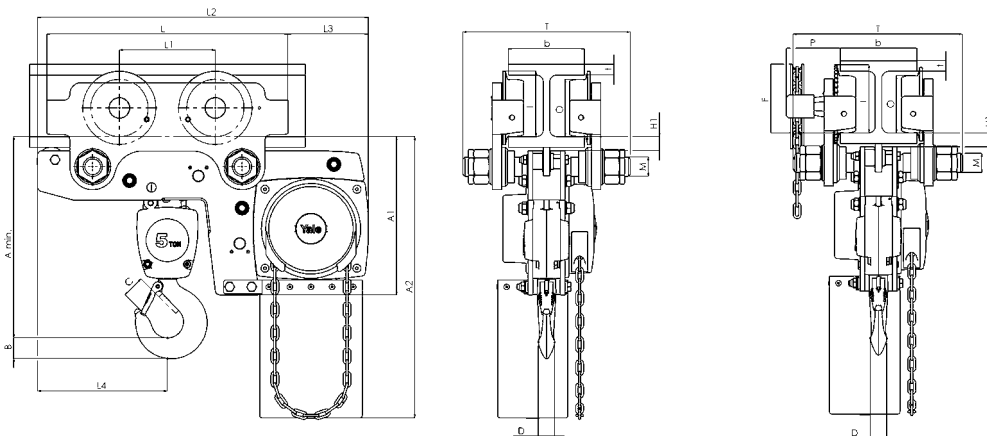

Model Yalelift LHP/LHG, 5000 kg, double fall

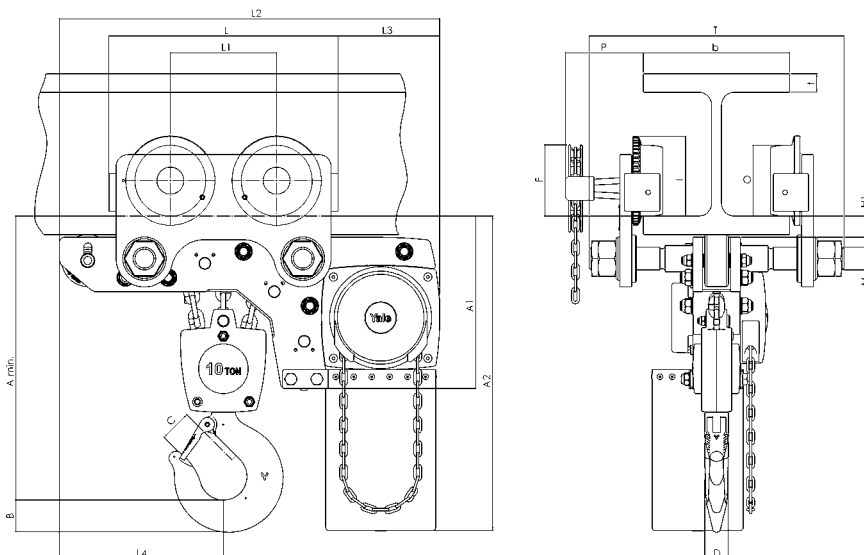

Model Yalelift LHG, 10000 kg, three fall



### Swivel truck low headroom trolley hoist model VLRP and model VLRG

Capacity 250 - 6000 kg

The hand chain hoist series VLR with integrated manual trolley drive features extremely low headroom capabilities and provides optimal usage of the available storage space in confined areas.

Hand wheel and gear case are positioned outside the reach of the bottom flange, thus allowing the bottom block to be raised almost until the underside of the beam. The swivel truck feature of the trolley suspension enables travelling on extremely short radius curves.

#### Features

- All-steel construction with zinc-plated load and hand chains.
- The integrated swivel truck trolley suspension permits application on runways with extremely narrow radii.
- All units are built to order for a predetermined beam dimension. They cannot be adjusted retro-actively to other beam sizes.
- Anti-drop and anti-tilt devices as standard.
- The rotating hand chain guide allows side-pull of the trolley hand chain in travel direction.

#### Options

- Overload prevention device.
- Chain container
- Buffers

**!** Beam profile and dimension as well as curve radius must always be specified when ordering.

*extremely low headroom  
for confined spaces*

## Technical data model VLRP and model VLRG

Model	Capacity	Beam flange width min.	Beam flange width max. straight beam	Beam flange thickness max.	Curve radius min.	Pull on hand chain at WLL	Weight
	kg	mm	mm	mm	m	daN	kg
VLRP 0.25	250	67	117	16	0.5	8	58
VLRP 0,5	500	67	117	16	0.5	16	58
VLRP 1,0	1000	76	117	16	0.5	32	58
VLRP 1,5	1500	86	140	16	0.8	26	113
VLRP 2,0	2000	86	140	16	0.8	35	115
VLRP 3,0	3000	102	178	16	1.0	19	158
VLRP 4,0	4000	102	178	16	1.0	27	160
VLRP 5,0	5000	117	203	22	1.2	33	213
VLRP 6,0	6000	117	203	22	1.2	41	213
VLRG 0,25	250	67	117	16	0.5	8	66
VLRG 0,5	500	67	117	16	0.5	16	66
VLRG 1,0	1000	76	117	16	0.5	32	66
VLRG 1,5	1500	86	140	16	0.8	26	122
VLRG 2,0	2000	86	140	16	0.8	35	123
VLRG 3,0	3000	102	178	16	1.0	19	172
VLRG 4,0	4000	102	178	16	1.0	27	175
VLRG 5,0	5000	117	203	22	1.2	33	227
VLRG 6,0	6000	117	203	22	1.2	41	227

## Dimensions model VLRP

Model	VLRP 0,25	VLRP 0,5	VLRP 1,0	VLRP 1,5	VLRP 2,0	VLRP 3,0	VLRP 4,0	VLRP 5,0	VLRP 6,0
A, mm	157	157	157	171	171	210	234	252	252
B, mm	51	51	51	56	56	68	65	71	71
C, mm	167	167	167	220	220	250	250	257	257
D, mm	167	167	167	220	220	250	250	257	257
E, mm	95	95	95	114	114	162	162	182	182
F, mm	127	127	127	152	152	203	203	229	229
G, mm	22	22	22	16	16	24	24	22	22
H, mm	25	25	25	29	29	34	42	42	42
K, mm	184	184	184	289	289	294	294	294	294
L, mm	165	165	165	194	194	195	195	223	223
M, mm	64	64	64	77	77	101	101	114	114
N, mm	35	35	35	77	77	77	77	77	77
O, mm	75	75	75	48	48	87	87	98	98



## Dimensions model VLRG

Model	VLRG 0,25	VLRG 0,5	VLRG 1,0	VLRG 1,5	VLRG 2,0	VLRG 3,0	VLRG 4,0	VLRG 5,0	VLRG 6,0
A, mm	157	157	157	171	171	210	234	252	252
B, mm	51	51	51	56	56	68	65	71	71
C, mm	167	167	167	220	220	250	250	257	257
D, mm	167	167	167	220	220	250	250	257	257
E, mm	95	95	95	114	114	162	162	182	182
F, mm	127	127	127	152	152	203	203	229	229
G, mm	22	22	22	16	16	24	24	22	22
H, mm	25	25	25	29	29	34	42	42	42
I, mm	119	119	119	182	182	206	206	216	216
J, mm	95	95	95	159	159	155	155	176	176
K, mm	184	184	184	289	289	294	294	294	294
L, mm	165	165	165	194	194	195	195	223	223
M, mm	64	64	64	77	77	101	101	114	114
N, mm	35	35	35	77	77	77	77	77	77
O, mm	75	75	75	48	48	87	87	98	98

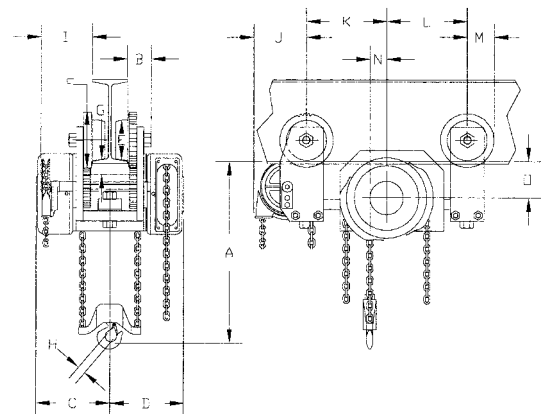





## Compact low headroom trolley hoist with integrated push trolley model VNRP and model VNRG

Capacity 1500 - 24000 kg

On account of a special chain reeving system and corresponding chain guide the trolley hoist series VNR offers minimum headroom and maximum usage of the available room height. These hoists have been specially designed for heavy industrial applications.

### Features

- All-steel construction with zinc-plated load and hand chains.
- All units are built to order for a predetermined beam dimension. They cannot be adjusted retro-actively to other beam sizes.
- Anti-drop and anti-tilt devices as standard.

### Options

- Chain container
- Buffers

### Technical data model VNRP and model VNRG

Model	Capacity kg	Lowest headroom hook dimension A mm	Curve radius min. m	Pull on hand chain at WLL daN	Weight kg
VNRP 1,5	1500	159	2.0	19	95
VNRP 2,0	2000	159	2.0	25	96
VNRP 3,0	3000	188	2.0	20	140
VNRP 4,0	4000	203	2.3	26	141
VNRP 5,0	5000	223	2.6	36	263
VNRP 6,0	6000	223	2.6	43	263
VNRP 8,0	8000	280	2.9	30	298
VNRP 10,0	10000	292	3.0	40	469
VNRP 12,0	12000	292	-	47	469
VNRP 16,0	16000	346	-	31	734
VNRP 20,0	20000	438	-	40	895
VNRP 24,0	24000	438	-	47	895
VNRG 1,5	1500	159	2.0	19	105
VNRG 2,0	2000	159	2.0	25	107
VNRG 3,0	3000	188	2.0	20	153
VNRG 4,0	4000	203	2.3	26	156
VNRG 5,0	5000	223	2.6	36	290
VNRG 6,0	6000	223	2.6	43	290
VNRG 8,0	8000	280	2.9	30	354
VNRG 10,0	10000	292	3.0	40	507
VNRG 12,0	12000	292	-	47	507
VNRG 16,0	16000	346	-	31	771
VNRG 20,0	20000	438	-	40	968
VNRG 24,0	24000	438	-	47	968

## Dimensions model VNRP

Model	VNRP 1,5	VNRP 2,0	VNRP 3,0	VNRP 4,0	VNRP 5,0	VNRP 6,0	VNRP 8,0	VNRP 10,0	VNRP 12,0	VNRP 16,0	VNRP 20,0	VNRP 24,0
A, mm	159	159	188	203	222	222	279	292	346	438	438	438
B, mm	518	518	518	518	667	667	667	667	667	772	772	772
C, mm	259	259	259	259	333	333	333	333	333	386	386	386
D, mm	259	259	259	259	333	333	333	333	333	386	386	386
E, mm	130	130	168	168	187	187	225	216	216	302	308	308
E', mm	130	130	168	168	187	187	225	248	248	302	314	314
F, mm	222	222	270	270	305	305	356	397	397	473	489	489
G, mm	210	210	270	270	305	305	343	365	365	473	483	483
J, mm	29	29	34	34	34	34	52	57	57	76	92	92
L, mm	29	29	34	34	36	36	43	44	44	51	51	51
M, mm	114	114	162	162	183	183	210	248	248	298	298	298
R, mm	332	332	332	332	419	419	419	419	419	477	468	468
S, mm	152	152	203	203	229	229	254	297	297	343	343	343

## Dimensions model VNRG

Model	VNRG 1,5	VNRG 2,0	VNRG 3,0	VNRG 4,0	VNRG 5,0	VNRG 6,0	VNRG 8,0	VNRG 10,0	VNRG 12,0	VNRG 16,0	VNRG 20,0	VNRG 24,0
A, mm	159	159	188	203	222	222	279	292	292	346	438	438
B, mm	518	518	518	518	667	667	667	667	667	772	772	772
C, mm	259	259	259	259	333	333	333	333	333	386	386	386
D, mm	259	259	259	259	333	333	333	333	333	386	386	386
E, mm	130	130	168	168	187	187	225	216	216	302	308	308
E', mm	130	130	168	168	187	187	225	248	248	302	314	314
F, mm	222	222	270	270	305	305	356	397	397	473	489	489
G, mm	210	210	270	270	305	305	343	365	365	473	483	483
J, mm	29	29	34	34	34	34	52	57	57	76	92	92
L, mm	29	29	34	34	36	36	43	44	44	51	51	51
M, mm	114	114	162	162	183	183	210	248	248	298	298	298
R, mm	332	332	332	332	419	419	419	419	419	477	468	468
S, mm	152	152	203	203	229	229	254	297	297	343	343	343

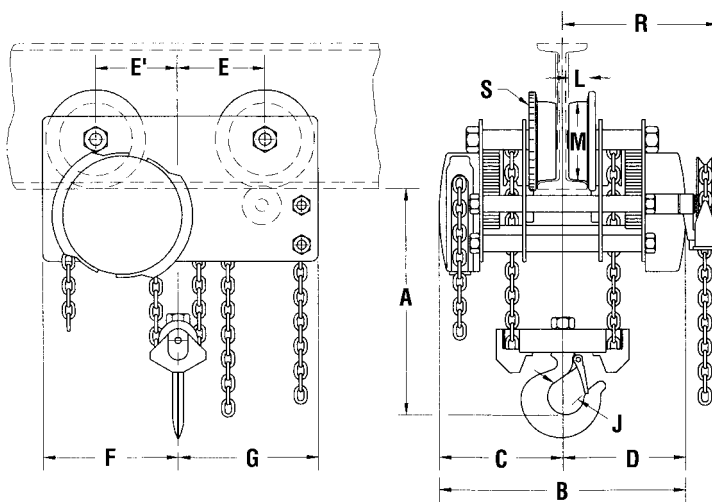

**Beam profile and dimension as well as curve radius must always be specified when ordering.**

**Yale hoists and trolleys are not designed for passenger elevation applications and must not be used for this purpose.**



## Corrosion protection CR

### More life expectancy.

All models of the Yalelift programme can be supplied with corrosion resistant features which include zinc-plated load chain and stainless steel hand chain as standard.

### Corrosion protection

Corrosion starts on the surface of components due to reaction of environmental influences. This affects the mechanical properties of the components, e.g. breaking load and total ultimate elongation.

Many components are supplied in black (unmachined), bright (machined) or painted condition. This offers certain protection but after only a short period of time corrosion can begin.

With the application of a protective coating, the development of corrosion can be reduced and delayed, thus extending the service life of the treated components.

### Applications

Completely corrosion resistant units with either zinc-plated or stainless steel hand and load chains should be used in all conditions with increased requirements towards corrosion protection.

Typical applications are in food processing (e.g. dairy, abattoir, etc.), chemical industries (e.g. paper, dye industries), farming and sewage treatment.

## Locking device

### More grip.

Yale trolleys can be attached with a locking device to secure the unit. (Parking position, e.g. shipping industry).

## Chain container

### More comfort.

The chain containers for the Yalelift programme consist of a robust, powder-coated steel frame with a flexible chain bag made from high tensile Cordura textile fabric. Available in different sizes. Special sizes on request.

## Overload protection

### More control.

The overload protection device of the Yalelift programme reliably prevents excessive load take-up of the hoist during operation. The overload protection device provides additional safety with regard to possible false estimation of the load weight and thus increases the lifetime of the hoist.



All models available in explosion proof version!

## Operation in explosion endangered environments.

### More safety.

In nearly all industrial areas, and not only in the chemical industry, plants are operated in explosion endangered environments. Because of the great damage an explosion could cause to people and material values, special stringent legal and technical requirements are imposed on particularly electrical equipment used in explosion endangered environments (according to 94/9/EC).



You would like to know more?  
Simply ask for our ATEX-brochure.

## Marking key

### Example

CE 123 Ex II 2 G Ex d T3

- CE-marking
- Code number of the notified body
- Identification for protection against explosions (ATEX 100a)
- Equipment group  
II = Non-mining application
- Category  
1 = extremely high safety  
2 = high safety  
3 = normal safety
- Ex atmosphere  
G = Gas  
D = Dust
- Explosion protection
- Protection type  
p = pressurized enclosure  
d = flame-proof enclosure  
e = increased safety  
nA = non-sparking  
i = intrinsic safety  
c = design safety  
b = ignition source monitoring  
k = liquid immersion
- Temperature class  
Limit temperature  
T1 = max. 450° C  
T2 = max. 300° C  
T3 = max. 200° C  
T4 = max. 135° C  
T5 = max. 100° C  
T6 = max. 85° C

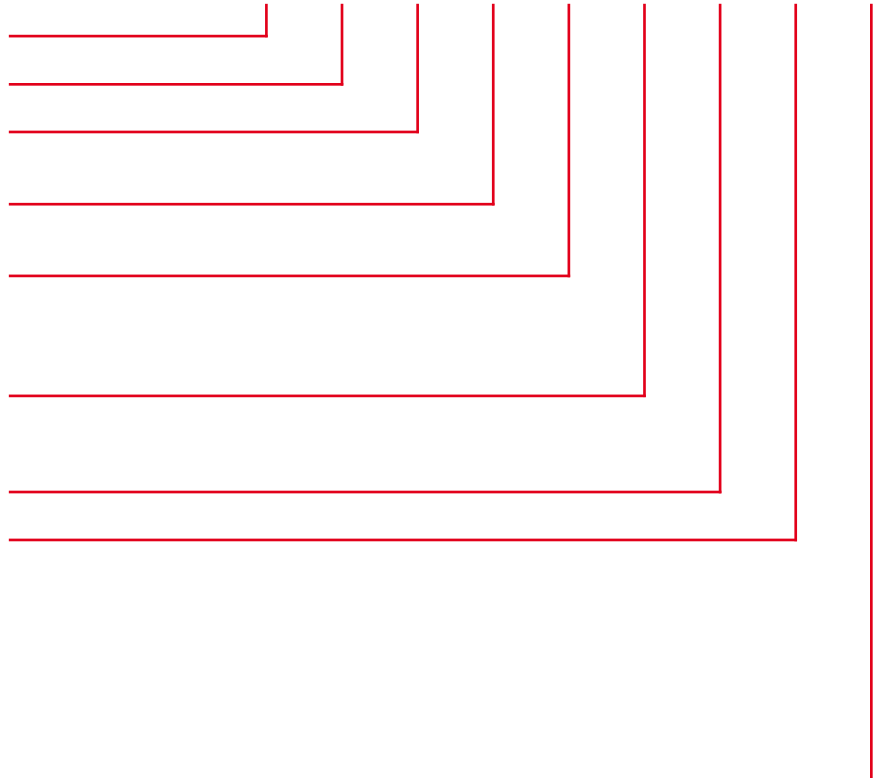

## Applications

Paint factories, paint shops, foundries, on-/offshore, refineries, oil depots, electroplating, automobile factories, on ships and docks, printers, textile and paper industries, food industries, glass and ceramic industries, wood working industries and hardening shops etc.

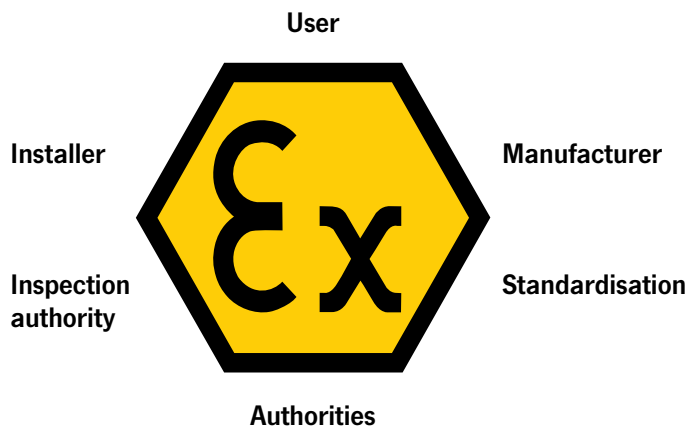

## Electro winch Model BETA-EX



Protection classification  
Ex II 2 GD de IIB T4 T 135°C



## Manual winch Model OMEGA-EX



Protection classification  
Ex II 2 GD ck IIB T3 195°C



Hand chain hoists  
& Trolleys

- Model Yalelift 360 ATEX
- Model Yalelift IT ATEX
- Model Yalelift LH ATEX
- Model HTP/G ATEX



Protection classification  
Ex II 2 GD c IIB T4 T 125° C X,  
Ex II 2 GD c IIB T3 T 145° C



Pneumatic chain hoists  
Model CPA ATEX



Protection classification  
Ex II 2 GD c IIB T4 T 125° C X,  
Ex II 2 GD c IIB T3 T 145° C



Ratchet lever hoists  
Model UNOplus ATEX



Protection classification  
⊕ I M2,  
⊕ II 2 GD c IIB T4 T 120° C X







### Push and geared type model HTP and model HTG

Capacity 500 - 20000 kg

The trolley enables the exact positioning or easy traversing of large loads with either manual or powered hoisting equipment.

#### Features

- It has excellent rolling features due to machined steel wheels mounted on prelubricated, encapsulated ball bearings.
- Adjustable to fit a wide range of beam widths and profiles (e.g. INP, IPE and IPB).
- Adjustments are made by rotating the clevis load bar which also ensures the centred positioning of the hoist in the clevis – no creeping to the left or the right.
- The trolley wheels are designed for a max. beam profile incline of 14% (DIN 1025 - part 1).
- Trolleys are in accordance with the UVV and machinery directives.

#### Options

- Rotating hand chain guide.
- Stainless steel hand chains.
- Buffers
- Corrosion resistant version
- Explosion protection
- Locking device to secure the trolley in position on the beam (park position e.g. on ships).

**!** No protection classification as no ignition source when utilized according to intended use.

**•** Applicable in zone 1, although the protection classification of the utilized hoist has to be considered.

## Technical data model HTP and model HTG

Model	EAN-No. 4025092*	Capacity kg	Size	Beam flange width b mm	Beam flange thickness t max. mm	Curve radius min. m	Hand effort at WLL daN	Weight* kg	Weight* with locking device kg
HTP 500	*054874	500	A	50 - 220	25	0.9	-	8.0	14.5
HTP 1000	*054881	1000	A	50 - 220	25	0.9	-	9.0	17.0
HTP 2000	*054898	2000	A	66 - 220	25	1.15	-	16.0	24.0
HTP 3000	*054904	3000	A	74 - 220	25	1.4	-	32.0	41.2
HTP 5000	*054911	5000	A	90 - 220	25	1.8	-	48.0	58.5
HTP 500	*054928	500	B	160 - 300	40	0.9	-	10.6	17.1
HTP 1000	*054935	1000	B	160 - 300	40	0.9	-	12.0	20.0
HTP 2000	*054942	2000	B	160 - 300	40	1.15	-	19.3	27.3
HTP 3000	*054959	3000	B	160 - 300	40	1.4	-	35.8	45.0
HTP 5000	*054966	5000	B	180 - 300	40	1.8	-	52.2	62.7
HTG 500	*074711	500	A	50 - 220	25	0.9	3	9.7	16.2
HTG 1000	*074728	1000	A	50 - 220	25	0.9	6	11.2	19.2
HTG 2000	*074735	2000	A	66 - 220	25	1.15	7	18.0	26.0
HTG 3000	*074742	3000	A	74 - 220	25	1.4	7	35.4	44.6
HTG 5000	*074759	5000	A	90 - 220	25	1.8	9	51.8	62.3
HTG 500	*074766	500	B	160 - 300	40	0.9	3	12.6	19.1
HTG 1000	*074841	1000	B	160 - 300	40	0.9	6	14.1	22.1
HTG 2000	*074773	2000	B	160 - 300	40	1.15	7	21.3	29.3
HTG 3000	*074780	3000	B	160 - 300	40	1.4	7	39.2	48.4
HTG 5000	*074797	5000	B	180 - 300	40	1.8	9	56.0	66.5
HTG 8000	*074803	8000	B	125 - 310	40	1.8	14	104.0	-
HTG 10000	*074810	10000	B	125 - 310	40	1.8	14	104.0	-
HTG 15000	*074827	15000	B	125 - 310	40	5.0	29	230.0	-
HTG 20000	*074834	20000	B	125 - 310	40	5.0	29	230.0	-

\*Weight HTG: without hand chain



**!** Yale hoists and trolleys are not designed for passenger elevation applications and must not be used for this purpose.

# Hoisting Equipment Trolleys & Trolley clamps

## Dimensions model HTP

Model	HTP 500-A	HTP 1000-A	HTP 2000-A	HTP 3000-A	HTP 5000-A	HTP 500-B	HTP 1000-B	HTP 2000-B	HTP 3000-B	HTP 5000-B
A, mm	77	82.5	98.5	114	132.5	92	97.5	113.5	129	147.5
D, mm	16	17	22	26	33	16	17	22	26	33
D1, mm	25	30	40	48	60	25	30	40	48	60
D2, mm	30	35	47	58	70	30	35	47	58	70
F1, mm	46	46	46	46	45.5	46	46	46	46	45.5
H1, mm	30.5	30.5	30.5	30	30	45.5	45.5	45.5	45	45
I (HTP), mm	71.5	71.5	95.5	131	142.5	71.5	71.5	95.5	131	142.5
L, mm	260	260	310	390	450	260	260	310	390	450
L1, mm	130	130	150	180	209	130	130	150	180	209
O, mm	60	60	80	112	125	60	60	80	112	125
P1, mm	168	168	168	168	168	168	168	168	168	168
P2, mm	146	150	155	160	167.5	146	150	155	160	167.5
L3, mm	346	346	396	476	556	346	346	396	476	556

## Dimensions model HTG

Model	HTG 500-A	HTG 1000-A	HTG 2000-A	HTG 3000-A	HTG 5000-A	HTG 500-B	HTG 1000-B	HTG 2000-B	HTG 3000-B	HTG 5000-B	HTG 8000-B	HTG 10000-B	HTG 15000-B	HTG 20000-B
A, mm	77	82.5	98.5	114	132.5	92	97.5	113.5	129	147.5	276	276	270	270
B, mm	-	-	-	-	-	-	-	-	-	-	52	52	70	70
D, mm	16	17	22	26	33	16	17	22	26	33	30	30	35	35
D1, mm	25	30	40	48	60	25	30	40	48	60	80	80	110	110
D2, mm	30	35	47	58	70	30	35	47	58	70	114	114	155	155
F (HTG), mm	91.5	91.5	90.5	107.5	149.5	91.5	91.5	90.5	107.5	149.5	113	113	113	113
F1, mm	46	46	46	46	45.5	46	46	46	46	45.5	77	77	-	-
H1, mm	30.5	30.5	30.5	30	30	45.5	45.5	45.5	45	45	45	45	45	45
I (HTG), mm	76.5	76.5	98	132.5	148.5	76.5	76.5	98	132.5	148.5	170	170	170	170
L, mm	260	260	310	390	450	260	260	310	390	450	430	430	870	870
L1, mm	130	130	150	180	209	130	130	150	180	209	200	200	200	200
L2, mm	-	-	-	-	-	-	-	-	-	-	-	-	115	115
O, mm	60	60	80	112	125	60	60	80	112	125	150	150	150	150
P (HTG), mm	110	110	110	110	110	110	110	110	110	110	163	163	163	163
P1, mm	168	168	168	168	168	168	168	168	168	168	193	193	-	-
P2, mm	146	150	155	160	167.5	187	187	189.5	191.5	191.5	-	-	-	-
T, mm	-	-	-	-	-	-	-	-	-	-	270	270	270	270
L3, mm	346	346	396	476	556	346	346	396	476	556	536	536	976	976
P3, mm	194	194	194	195	195	194	194	194	195	195	-	-	-	-

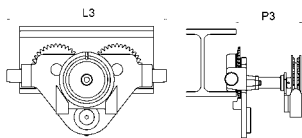

Model HTG 500 - 5000 kg  
with rotating hand chain guide and  
buffers

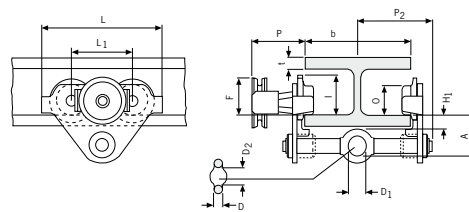

Model HTP/G 500 - 5000 kg

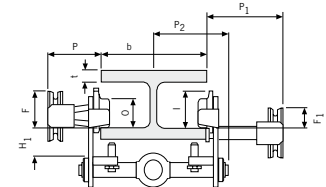

Model HTP/G 500 - 5000 kg,  
with locking device

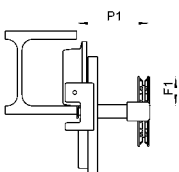

Model HTG 10000 kg,  
locking device

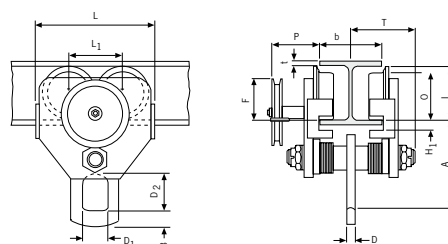

Model HTG 10000 kg

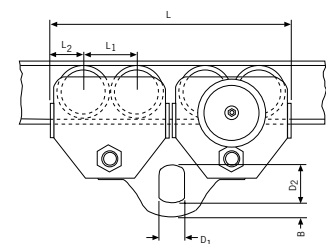

Model HTG 20000 kg

## Trolley clamp model CTP

Capacity 1000 - 3000 kg

Easy fitting to overhead beams for the attachment and transport of loads.

### Features

- Central threaded spindle provides quick adjustment to the required beam width.
- Threaded spindle and clevis are zinc-plated for added corrosion protection.



### Technical data model CTP

Model	EAN-No. 4025092*	Capacity kg	Beam flange width b mm	Curve radius min. m	Weight kg
CTP 1-A	*063012	1000	60 - 150	0.6	2.5
CTP 2-A	*055437	2000	75 - 200	0.9	9.9
CTP 2-B	*055444	2000	200 - 300	0.9	10.3
CTP 3-A	*055451	3000	75 - 200	1.15	17.5
CTP 3-B	*055468	3000	200 - 320	1.15	19.5

### Dimensions model CTP

Model	CTP 1-A	CTP 2-A	CTP 2-B	CTP 3-A	CTP 3-B
A, mm	82 - 109	106 - 155	136 - 191	128 - 171	150 - 212
D, mm	26	42	42	50	50
E, mm	22	20	20	22	22
H1, mm	20	24	24	30.5	30.5
I, mm	53	71.5	71.5	95.5	95.5
L, mm	160	260	260	310	310
L1, mm	75	130	130	150	150
M, mm	M12	M18	M18	M24	M24
O, mm	46	60	60	80	80
P, mm	153	205	255	220	280
T, mm	105	139	189	155	215
t max., mm	15	25	25	25	25

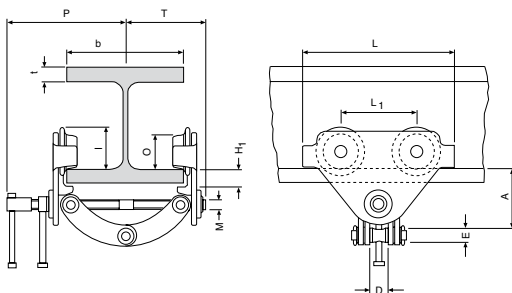

**!** Yale hoists and trolleys are not designed for passenger elevation applications and must not be used for this purpose.



## Swivel truck trolley with low headroom and extremely short curve radius model VLHP and model VLHG

Capacity 250 - 6000 kg

The manual trolley series VLH features extremely low headroom. The swivel truck construction allows negotiation of very short curve radius.

### Features

- All-steel construction with low headroom.
- All units are built to order for a predetermined beam dimension. They cannot be adjusted retro-actively to other beam sizes.
- Anti-drop and anti-tilt devices as standard.

### Options

- Buffers
- Large variety of special versions.

Beam profile and dimension as well as curve radius must always be specified when ordering.

### Technical data model VLHP

Model	Capacity kg	Beam flange width min. mm	Beam flange width max. straight beam mm	Beam flange thickness max. mm	Curve radius min. m	Weight kg
VLHP 0,25	250	67	117	16	0.3	20
VLHP 0,5	500	67	117	16	0.3	20
VLHP 1,0	1000	76	117	16	0.3	27
VLHP 1,5	1500	86	140	16	0.5	38
VLHP 2,0	2000	86	140	16	0.5	38
VLHP 3,0	3000	102	178	16	0.4	71
VLHP 4,0	4000	102	178	16	0.4	71
VLHP 5,0	5000	117	203	22	0.9	125
VLHP 6,0	6000	117	203	22	0.9	125
VLHG 0,25	250	67	117	16	0.3	29
VLHG 0,5	500	67	117	16	0.3	29
VLHG 1,0	1000	76	117	16	0.3	35
VLHG 1,5	1500	86	140	16	0.5	48
VLHG 2,0	2000	86	140	16	0.5	48
VLHG 3,0	3000	102	178	16	0.4	85
VLHG 4,0	4000	102	178	16	0.4	85
VLHG 5,0	5000	117	203	22	0.9	140
VLHG 6,0	6000	117	203	22	0.9	140

## Dimensions model VLHP

Model	VLHP 0,25	VLHP 0,5	VLHP 1,0	VLHP 1,5	VLHP 2,0	VLHP 3,0	VLHP 4,0	VLHP 5,0	VLHP 6,0
B, mm	298	298	330	413	413	476	476	565	565
C, mm	279	279	305	362	362	445	445	527	527
D, mm	8	8	8	6	6	6	6	5	5
F, mm	178	178	178	210	210	241	241	298	298
G, mm	103	103	111	114	114	165	165	194	194
H, mm	124	124	130	140	140	204	204	264	264
K, mm	114	114	121	127	127	152	152	194	194
L, mm	41	41	32	44	44	52	52	68	68
M, mm	22	22	28	29	29	34	34	48	48
N, mm	110	110	111	127	127	152	152	191	191
P, mm	64	64	64	76	76	95	95	140	140
Q, mm	32	32	32	38	38	51	51	76	76
R, mm	73	73	95	114	114	162	162	183	183
S, mm	92	92	127	152	152	203	203	229	229
T, mm	10	10	25	25	25	29	29	64	64

## Dimensions model VLHG

Model	VLHG 0,25	VLHG 0,5	VLHG 1,0	VLHG 1,5	VLHG 2,0	VLHG 3,0	VLHG 4,0	VLHG 5,0	VLHG 6,0
A, mm	391	391	402	451	451	527	527	649	649
B, mm	324	324	343	413	413	476	476	565	565
C, mm	305	305	316	362	362	445	445	527	527
D, mm	6	6	8	6	6	6	6	6	6
E, mm	130	130	135	135	135	168	168	214	214
F, mm	178	178	178	210	210	241	241	298	298
G, mm	103	103	111	114	114	165	165	194	194
H, mm	124	124	130	140	140	204	204	264	264
I, mm	113	113	113	122	122	149	149	173	173
J, mm	232	232	232	222	222	248	248	287	287
K, mm	114	114	121	127	127	152	152	194	194
L, mm	40	40	32	44	44	52	52	68	68
M, mm	22	22	28	28	28	29	29	37	37
N, mm	110	110	111	127	127	152	152	191	191
O, mm	200	200	200	200	200	216	216	254	254
P, mm	64	64	64	76	76	95	95	140	140
Q, mm	32	32	32	38	38	51	51	76	76
R, mm	73	73	95	114	114	162	162	183	183
S, mm	102	102	127	152	152	203	203	229	229
T, mm	10	10	25	25	25	29	29	64	64

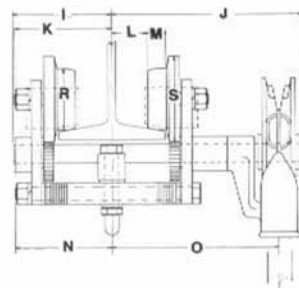
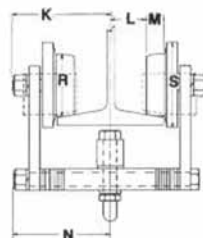
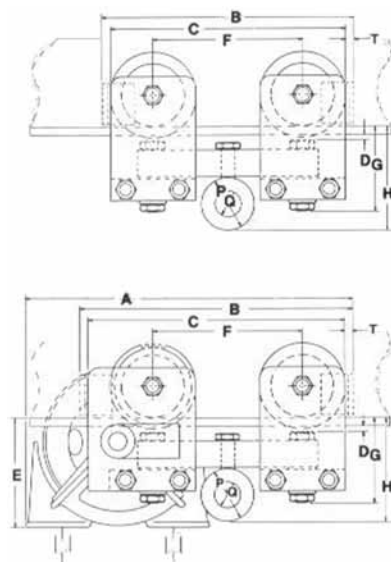

**!** Yale hoists and trolleys are not designed for passenger elevation applications and must not be used for this purpose.





## Electric trolley model VTE-U

### Capacity 1000 - 5000 kg

Specially recommended for loads over 1000 kg, for transporting over long distances and/or when used frequently. Suitable for almost all hoists with suspension hook due to universal shackle connection.

Travel motor with worm gear transmission ensures smooth start and self braking – a separate motor brake is not required.

### Features

- Standard operating voltage:  
Euro-voltage 400 V, 3-phase, 50 Hz.  
Single speed motors can be reconnected to 230 V.
- Motor protected to IP 55 against dust and water jets.  
Push-button pendant control, IP 65.
- Compact, robust frame with low overall height.
- Wheels manufactured from fracture-proof steel. Smooth running due to machined surfaces and ball bearing mounting. Cambered profile suitable for parallel and inclined beam profiles.
- Anti-drop and anti-tilt devices as standard.
- Easy adjusted to fit to a wide range of beam widths and profiles due to threaded spindles.

### Options

- Low voltage control (42 V)
- Rubber buffers
- 230 V, 1-phase, 50 Hz



Wheel with cambered profile



Threaded spindle



Anti-drop device with option to fit buffers.

## Technical data model VTE-U

Model	EAN-No. 4025092*	Capacity kg	Travel speed m/min	Motor kW	Beam flange width mm	Beam flange thickness max. mm	Curve radius min. m	Weight kg
VTE 1-A-18/U*	*073547	1000	18 or 18/4.5	0.18 or 0.18/0.06	58 - 180	19	0.9	19.5
VTE 1-B-18/U*	*073585	1000	18 or 18/4.5	0.18 or 0.18/0.06	180 - 300	19	0.9	25.2
VTE 2-A-18/U*	*073561	2000	18 or 18/4.5	0.18 or 0.18/0.06	58 - 180	19	1.15	26.0
VTE 2-B-18/U*	*073608	2000	18 or 18/4.5	0.18 or 0.18/0.06	180 - 300	19	1.15	30.2
VTE 3-A-11/U	*073424	3000	11 or 11/2.8	0.37 or 0.3/0.09	74 - 180	27	1.5	51.0
VTE 3-B-11/U	*073509	3000	11 or 11/2.8	0.37 or 0.3/0.09	180 - 300	27	1.4	53.0
VTE 5-A-11/U	*073448	5000	11 or 11/2.8	0.37 or 0.3/0.09	98 - 180	27	2.0	77.0
VTE 5-B-11/U	*073523	5000	11 or 11/2.8	0.37 or 0.3/0.09	180 - 300	27	1.8	80.0

\*11 or 11/2.8 m/min. Travel speed on request

## Dimensions model VTE-U

Model	VTE 1-A-18/U	VTE 1-B-18/U	VTE 2-A-18/U	VTE 2-B-18/U	VTE 3-A-11/U	VTE 3-B-11/U	VTE 5-A-11/U	VTE 5-B-11/U
A, mm	113	113	115	115	139	139	161	161
B, mm	b + 50	b + 50	b + 54	b + 54	b + 60	b + 60	b + 70	b + 70
C, mm	49	49	47	47	57	57	60	60
D, mm	16	16	16	16	19	19	22	22
E, mm	187	187	187	187	202	202	202	202
F, mm	94	94	94	94	94	94	94	94
G, mm	43	43	43	43	51	51	58	58
H, mm	129	129	128	128	144	144	178	178
H1, mm	24	24	24	24	32	32	32	32
I, mm	77	77	98	98	133	133	149	149
L1, mm	130	130	150	150	180	180	209	209
M, mm	155	155	180	180	208	208	263	263
N single speed, mm	255	255	255	255	292	292	292	292
N double speed, mm	263	263	263	263	296	296	296	296
O, mm	60	60	80	80	112	112	125	125
P, mm	123	123	123	123	129	129	121	121
Q, mm	145	205	153	213	160	220	182	242

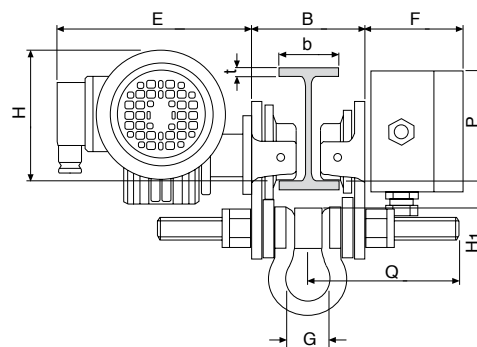
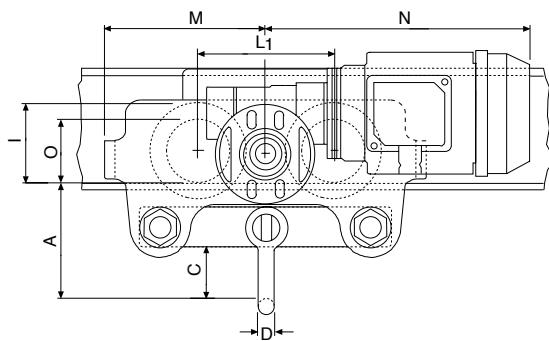

**Yale hoists and trolleys are not designed for passenger elevation applications and must not be used for this purpose.**



## Beam clamp model YRC

### Capacity 1000 - 10000 kg

Compact and rigid beam clamp to be used as a versatile rigging point for hoisting equipment and loads.

Flexible application due to wide adjustment range.

The central threaded spindle allows easy attachment and a safe and secure grip. The spindle can be secured against loosening.

### Features

- Extremely robust due to reinforced side plates and jaws, for a safe attachment point even under demanding conditions.
- Easy handling due to proven threaded spindle mechanism.
- Flattened clamping jaws for use even in confined spaces.

### Technical data model YRC

Model	EAN-No. 4025092*	Capacity kg	Beam flange width mm	Weight kg
YRC 1	*080682	1000	75 - 230	4.8
YRC 2	*080699	2000	75 - 230	6.2
YRC 3	*080705	3000	80 - 320	12.6
YRC 5	*080712	5000	90 - 320	14.3
YRC 10	*080729	10000	90 - 320	24.0

**Yale hoists and trolleys are not designed for passenger elevation applications and must not be used for this purpose.**

### Dimensions model YRC

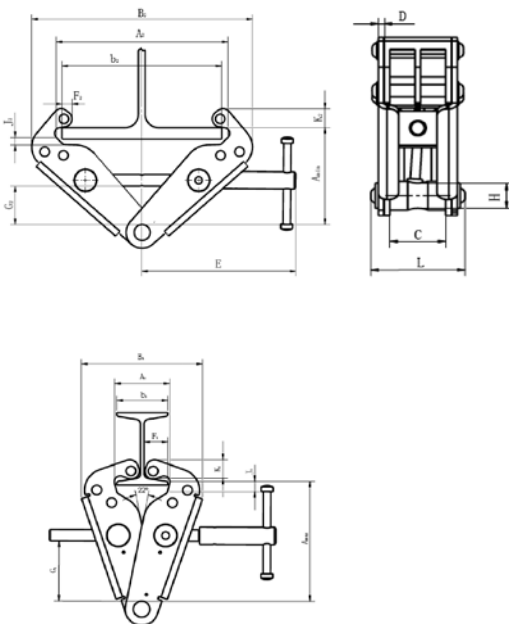

Model	YRC 1	YRC 2	YRC 3	YRC 5	YRC 10
A min., mm	135	135	183	183	202
A max., mm	165	165	224	224	241
A1, mm	74	74	97	97	114
A2, mm	238	238	330	330	340
B1, mm	161	163	212	216	263
b1, mm	68	68	80	80	90
B2, mm	300	304	425	425	475
b2, mm	230	230	320	320	320
C, mm	45	58	69	69	69
D, mm	4	6	8	10	12
E, mm	212	212	303	303	304
F1, mm	32	32	37	37	40
F2, mm	19	19	30	30	31
G1, mm	83	83	118	118	112
G2, mm	53	53	79	79	80
H, mm	20	20	32	32	44
J1, mm	14	14	22	22	27
J2, mm	26	26	37	37	41
K1, mm	26	26	41	41	53
K2, mm	26	26	32	32	40
L, mm	77	97	117	125	133

## Beam clamp model YC

Capacity 1000 - 10000 kg

Provides a quick and versatile rigging point for hoisting equipment, pulley blocks or loads. Flexible application due to wide adjustment range. The central threaded spindle allows easy attachment and a safe and secure grip. The spindle can be secured against loosening.

### Options

- Can be supplied with shackle (other jaw capacities).



### Technical data model YC

Model	EAN-No. 4025092*	Capacity kg	Beam flange width mm	Weight kg
YC 1	*055154	1000	75 - 230	3.8
YC 2	*055161	2000	75 - 230	4.6
YC 3	*055192	3000	80 - 320	9.2
YC 5	*055208	5000	90 - 320	11.0
YC 10	*055215	10000	90 - 320	17.2

**!** Yale hoists and trolleys are not designed for passenger elevation applications and must not be used for this purpose.

### Dimensions model YC

Model	YC 1	YC 2	YC 3	YC 5	YC 10
A min., mm	115	115	180	180	175
A max., mm	150	150	225	225	220
A1, mm	78	78	80	90	90
A2, mm	246	246	320	310	320
B1, mm	186	186	232	242	268
B2, mm	350	350	455	445	480
b1, mm	75	75	80	90	90
b2, mm	230	230	320	310	320
C, mm	50	50	70	70	70
D, mm	4	6	8	10	14
E, mm	215	215	255	255	275
F1, mm	34	35	35	35	35
F2, mm	17	18	21	21	20
G1, mm	82	82	120	116	110
G2, mm	44	44	75	75	66
H, mm	20	20	22	28	38
J1, mm	14	14	30	30	34
J2, mm	21	21	34	34	35
K1, mm	48	50	60	60	60
K2, mm	31	32	40	42	40
L, mm	84	94	122	129	146

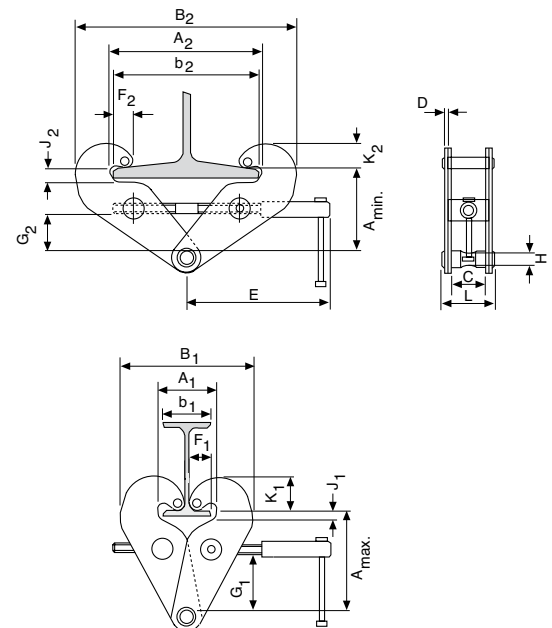

**!** Also useable as a horizontal rigging point.

Also applicable as lifting clamp.

## General information about electric chain hoists

Apart from the usual criterion such as lifting capacity, lifting speed and dimensions also consider following:

### 1. Choosing a motor according to FEM 9.683

In addition to the torque the decisive criterion for rating an electric motor is the heat it generates. Here we differentiate between two operational modes:

#### 1.1 Intermittent duty

In this case the motor is designed for a series of equal cycles consisting of duty periods with constant load and rest periods. The heat generation depends on the relative duty cycle, that is, the relationship between operating period under load, total operating time and the number of starts/hour.

$$ED = \frac{\text{Operating period}}{\text{Operating period} + \text{rest periods}} \%$$

The number of cycles that can be made under full load is calculated as follows:

$$S \approx 0.3 \times \frac{ED \times V}{H}$$

S = Cycles per hour  
 ED = Duty rating in %  
 V = Lifting speed in m/min.  
 H = Average lifting height in m

A cycle consists of a motion of lifting, lowering and the rest periods. One must ensure that the lifting height does not exceed the value permitted by the percentage duty cycle referred to a cycle period of 10 minutes

$$H \leq \frac{ED \times V}{20}$$

and that simultaneously the permissible number of starts is not exceeded. It is generally accepted that a cycle consists of 6 starts.

#### 1.2 Short time duty

Where special duty conditions exist (e.g. long hook path) the operating period must be of such length that the admissible temperature limit of the motor is not exceeded. For such cases intermittent duty must be replaced by short time duty. That is, the motor may be operated for up to 10 starts over a certain period (with Yale products 30 min.). Thereafter the motor must cool down to room temperature.

#### 1.3 Calculation example intermittant duty

Electric hoist	:	CPV 5-8
Lifting speed	:	8 m/min.
Lifting height	:	2.8 m
Duty rating ED	:	50 %
c/h	:	180

Number of cycles per hour.

$$S = 0.3 \times \frac{50 \times 8}{20} = 42.8$$

Max. lifting height

$$H = 2.8 \leq \frac{50 \times 8}{20} = 20 \text{ m}$$

Number of starts

$$N = \frac{25 \text{ cycles}}{\text{hour}} \times \frac{6 \text{ starts}}{\text{cycle}} = 150 \text{ c/h}$$

## 2. Classification of hoisting equipment according to FEM 9.511

To choose an optimal hoist the lifting capacity and also the classification group must be known. The classification group indicates the theoretical operating time of the mechanical components under full load:

Classification group	FEM ISO	1 Bm M3	1 Am M4	2 m M5	3 m M6
Operating time in h	400	800	1600	3200	

If the hoist is operated as classified an actual operating time of around 10 years can be expected. After this period a general overhaul is necessary.

To define the classification group following values must be determined:

### 2.1 Average operating time per day

The average operating time can be estimated or calculated as follows:

$$\text{Operating time/day} = \frac{2 \times \text{average hook path} \times \text{cycles /hour} \times \text{operating time/day}}{60 \times \text{lifting speed}}$$

### 2.2 Load spectrum

The load spectrum indicates to what extent a hoist or part thereof is subject to maximal stress or whether it is subject to smaller loads only. It can be calculated or estimated according to the diagrams on the right:

**1 light**  
Hoists or parts thereof usually subject to very small loads and in exceptional cases only to maximum loads.

**2 medium**  
Hoists or parts thereof usually subject to small loads but rather often to maximum loads.

**3 heavy**  
Hoists or parts thereof usually subject to medium loads but frequently to maximum loads.

**4 very heavy**  
Hoists or parts thereof usually subject to maximum or almost maximum loads.

### 2.3 Classification

The classification group is defined by operating hours and load spectrum:

Load spectrum	Aver. op. hours per working day		
1 light	up to 2	2-4	4-8
2 medium	up to 1	1-2	2-4
3 heavy	up to 0.5	0.5-1	1-2
4 very heavy	up to 0.25	0.25-0,5	0.5-1
Classification group acc. to FEM/ISO	1 Bm/M3	1 Am/M4	2 m/M5





## Motor surface cooled

Protection	1 <sup>st</sup> digit		2 <sup>nd</sup> digit
	Contact protection	Ingress of solid foreign particles	Ingress of liquid
IP 44	contact with tools or similar	against solid foreign bodies over 1 mm Ø	splashing from all directions
IP 50	complete protection against contact	damaging dust deposits	no protection
IP 54	contact with tools or similar	against solid foreign bodies over 1 mm Ø	splashing from all directions
IP 55	complete protection against contact	damaging dust deposits	water jets from all directions
IP 56	complete protection against contact	damaging dust deposits	momentarily flooding
IP 65	complete protection against contact	against ingress of dust	water jets from all directions

## IP protection according to EN 60529

Depending on the operating and environmental conditions the damaging effect of water, foreign particles and dust and the contact with live or moving parts inside a motor is to be prevented by choosing a suitable protection.

The marking used to indicate the degree of protection consists of the letters IP followed by two characteristic numerals.

The marking applies to the unit as it is supplied and the defined or usual location of the unit.

The protection can change if the unit is located or fitted differently.

## Protection against contact and solid foreign particles

### First digit 0 No protection

No protection of persons against contact with live or moving parts inside the enclosure. No protection of equipment against ingress of solid foreign particles.

### First digit 1 Protection against large solid foreign particles

Protection against accidental or inadvertent contact with live or moving parts inside the enclosure by a large surface of the human body, e.g. hand, but not protected against deliberate access to such parts.

### First digit 2 Protection against med. size solid foreign particles

Protection against contact with live or moving parts inside the enclosure by fingers. Protection against ingress of medium size solid foreign particles of diameter greater than 12 mm.

### First digit 3 Protection against small solid foreign particles

Protection against contact with live or moving parts inside the enclosure by tools, wires or such objects of thickness greater than 2.5 mm. Protection against ingress of small solid foreign particles of diameter greater than 2,5 mm.

### First digit 4 Protection against granular structured foreign particles

Protection against contact with live or moving parts inside the enclosure by tools, wires or such objects of thickness greater than 1 mm. Protection against ingress of granular structured solid foreign particles of diameter greater than 1 mm.

### First digit 5 Protection against dust deposits

Complete protection against contact with live or moving parts inside the enclosure. Protection against harmful deposits of dust. The ingress of dust is not totally prevented, but dust cannot enter in an amount sufficient to interfere with the satisfactory operation of the equipment enclosed.

### First digit 6 Complete protection

Complete protection against contact with live or moving parts inside the enclosure. Protected against the ingress of dust.

## Protection against liquids

### Second digit 0 No protection

No particular protection

### Second digit 1 Protection against vertical water drops

Droplets of condensed water falling on the enclosure shall have no harmful effects.

### Second digit 2 Protection against diagonal falling water drops

Protection against dripping liquids. Droplets of falling liquid shall have no harmful effect when the enclosure is tilted at any angle up to 15° from the vertical.

### Second digit 3 Protection against spray water

Protection against dripping liquids. Water falling as rain at an angle equal to or smaller than 60° in respect to the vertical shall have no harmful effect.

### Second digit 4 Protection against splashing

Liquid splashed from any direction shall have no harmful effect.

### Second digit 5 Protection against water jets

Water projected by a nozzle from any direction under stated conditions shall have no harmful effect.

### Second digit 6 Protection against flooding

Protection against conditions on ships decks (deck watertight equipment). Water from heavy seas shall not enter the enclosure under prescribed conditions<sup>2)</sup>.

### Second digit 7 Protection against immersion in water

It shall not be possible for water to enter the enclosure under stated conditions of pressure and time<sup>2)</sup>.

### Second digit 8 Protection against indefinite immersion

Protection against indefinite immersion in water.

Under specific pressure it shall not be possible for water to enter the enclosure<sup>2)</sup>.

<sup>2)</sup>In certain cases water should not ingress. As required this is defined on the follow-on page of the unit in question.

Technical questionnaire for choosing a suitable electric chain hoist

Company: \_\_\_\_\_

Date: \_\_\_\_\_

Contact: \_\_\_\_\_

e-Mail: \_\_\_\_\_

Phone: \_\_\_\_\_

Fax: \_\_\_\_\_

Details about intended use

---



---



---



---



---

Required capacity

---

Lifting height

---

Ambient conditions

- Normal
- Humidity
- Dust
- Dirt
- Particular temperatures \_\_\_\_\_ °C
- Increased rel. humidity \_\_\_\_\_ %
- Other

---



---

How long is the hoist in operation

- \_\_\_\_\_ Load cycles per hour
- \_\_\_\_\_ Hours per day
- \_\_\_\_\_ Days per week
- \_\_\_\_\_ Distance covered per lifting cycle

Unusual operating conditions that could be important for the choice and function of the electric chain hoist:

Type of load

- Permanent
- Changing
- Shocks
- Vibration
- Static

Trolley drive

- Motor
- Manual

Operating voltage

- 400 V
- 230 V
- 3-phase a.c.
- 1-phase a.c.

Power frequency

- 50 Hz
- 60 Hz

Protection

- IP 54
- Other





### Electric chain hoist model CPS with suspension hook

Capacity 125 - 500 kg

The model CPS is the smallest and lightest model within the range of Yale electric chain hoists. Reliability and compact design make it ideal for numerous applications in the construction industry, service companies and many industrial areas for moving small and medium loads.

#### Features

- Classification: 1 Am/M4 (standard), resp. 1 Bm/M3 at 230V, 1-phase, 50 Hz. As required the model CPS (with appropriate changes to lifting capacity resp. duty cycle) can also be re-classified.
- The standard version comes with direct control.
- Two year warranty (excluding wear parts).
- Thermal overload protection as standard.
- Duty cycle 30 % ED, resp. 25 % ED. 230V, 1-phase, 50 Hz.
- Safe hold of the load even in case of electric failure due to electromagnetic, spring pressure brake.
- Standard operating voltage: Euro-voltage 400V, 3-phase, 50 Hz, resp. 125 kg also as 230V, 1-phase, 50 Hz version.
- Motor protected to IP 54, against ingress of dust and splashing.
- Push-button pendant control, IP 65 against ingress of dust and water jets from all directions.
- The overload protection (slip clutch) avoids overloading and extends the lifetime of the hoist.
- Robust aluminium housing, powder coated.
- Extremely low headroom
- The standard case hardened and zinc-plated link chain is matched perfectly to the load chain to guarantee smooth and precise chain motion. All requirements of national and international standards and regulations are fulfilled.
- The 10-pocket load sheave ensures smooth running of the chain and minimizes chain wear.
- Drop forged suspension and load hooks are made from non-aging, high tensile steel and fitted with robust safety latches.

**Festooned cable systems**  
see page 144-145.

#### Options

- Stainless steel load chain (no reduction of working load limit).
- Robust chain container
- Low voltage control 48V
- Manual and electric trolleys.
- Connection to festooned cable systems.

## Technical data model CPS

Model	EAN-No. 4025092*	Capacity in kg/ number of chain falls	Standard lifting height m	Chain dimensions d x p mm	Classification FEM/ISO	Lifting speed m/min	Hoist motor kW	Weight kg	Operating voltage
CPS 1-4	*076654	125/1	3	4 x 12.2	1Bm/M3	4	0.10	11.5	230V/1-phase/50 Hz
CPS 1-10	*076661	125/1	3	4 x 12.2	1Am/M4	10	0.25	11.5	400V/3-phase/50 Hz
CPS 2-6	*076678	250/1	3	4 x 12.2	1Am/M4	6	0.28	11.5	400V/3-phase/50 Hz
CPS 5-3	*076685	500/2	3	4 x 12.2	1Am/M4	3	0.28	12.5	400V/3-phase/50 Hz

## Dimensions model CPS

Model	CPS 1-4	CPS 1-10	CPS 2-6	CPS 5-3
A, mm	276	276	276	303
B, mm	98	98	98	146
C, mm	159	159	159	159
D, mm	75	75	75	60
E, mm	76	76	76	91
F, mm	160	160	160	160
G, mm	227	227	227	227
H, mm	103	103	103	103
I, mm	52	52	52	52
J*, mm	1905	1905	1905	1905
X, mm	25	25	25	25
Y, mm	14	14	14	14
Z, mm	21	21	21	21

\*Dimensions at standard lift (3 m).

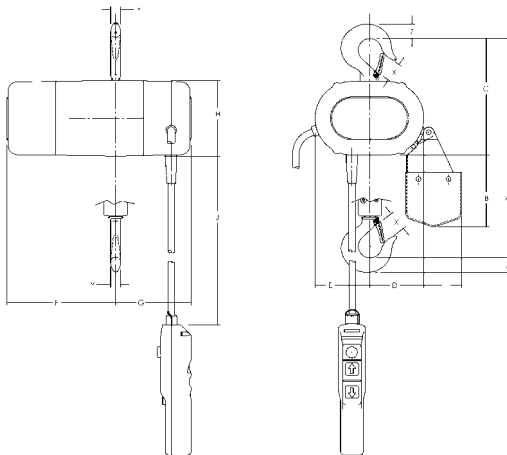

Smallest and lightest electric chain hoist for a great number of applications.

**!** Yale hoists and trolleys are not designed for passenger elevation applications and must not be used for this purpose.



*High speed units available*

## Options

- Stainless steel load chain (no reduction of working load limit).
- Suspension hook
- Flexible chain container.
- Other operating voltages.
- Counter for operating hours and number of starts.
- Radio remote control
- Control for synchronized operation of several hoists.
- Manual and electric trolleys.
- Connection to festooned cable systems.

## Electric chain hoist model CPV with suspension lug or with integrated trolley

Capacity 250 - 2000 kg

The electric chain hoist model CPV combines modern design and technical innovation. A robust construction makes the series a versatile tool for professional applications. The integrated limit switch for the highest and lowest hook position considerably extends the working life span of the slip clutch, motor and gearbox.

### Features

- Classification: 1 Am/M4 (standard), resp. 1 Bm/M3 (for 230V, 1-phase, 50 Hz). As required (with appropriate changes to lifting capacity resp. duty cycle) the model CPV can also be re-classified up to 3 m/M6.
- Main contactor as standard, for increased safety.
- Increased operating safety through 42V control voltage (low voltage control), push-button pendant control, IP 65.
- 2 year warranty (excluding wear parts) and a lifetime lubricated gearbox.
- Duty cycle 50% ED for single speed.
- Electromagnetic spring pressure brake holds the load safely even in the event of power failure.
- Standard operating voltage: Euro-voltage 400V, 3-phase, 50 Hz, alternatively 460V, 3-phase, 60Hz. Single speed motors reconnectable to 230V, 3-phase, 50 Hz.
- Motor protected to IP 55 (acc. to VDE 0530), against ingress of dust and water jets.
- The externally adjustable slip clutch is designed to guarantee a permanent connection between the load and the brake.
- The standard, oil bath lubricated and case hardened gearbox has a helical gearing for particularly smooth running and enhanced lifetime.
- Suspension lug for compact dimensions and easy integration in closed-eye constructions.
- Chain guide made of fibre coated polyamide for increased wear resistance.

**Also available as 230V, 1-phase, 50 Hz (25% ED) version.**  
**Optionally available with electric trolley.**

## Technical data model CPV/CPVF

Model	EAN-No. 4025092*	Capacity in kg/ number of chain falls	Chain dimensions d x p  mm	Classification  FEM/ISO	Lifting speed**** main lift  m/min	Lifting speed fine lift  m/min	Hoist motor  kW	Motor rating  ED %	Weight* suspension lug  kg	Weight* push trolley**  kg	Weight* electric trolley***  kg
CPV 2-8	*173070	250/1	4 x 12.2	1Am/M4	8	-	0.37	50	24	39	47
CPVF 2-8	*173063	250/1	4 x 12.2	1Am/M4	8	2	0.37/0.09	33/17	25	40	48
CPV 2-20	-	250/1	5 x 15.1	1Am/M4	20	-	0.75	50	26	41	49
CPVF 2-20	-	250/1	5 x 15.1	1Am/M4	20	5	0.75/0.18	33/17	27	42	50
CPV 5-4	*174466	500/2	4 x 12.2	1Am/M4	4	-	0.37	50	25	40	48
CPVF 5-4	*174442	500/2	4 x 12.2	1Am/M4	4	1	0.37/0.09	33/17	26	41	49
CPV 5-8	*173766	500/1	5 x 15.1	1Am/M4	8	-	0.75	50	26	41	49
CPVF 5-8	*173803	500/1	5 x 15.1	1Am/M4	8	2	0.75/0.18	33/17	27	42	50
CPV 5-20	-	500/1	7.1 x 20.5	1Am/M4	20	-	1.5	50	58	77	84
CPVF 5-20	-	500/1	7.1 x 20.5	1Am/M4	20	5	1.5/0.37	33/17	59	78	85
CPV 10-4	*174473	1000/2	5 x 15.1	1Am/M4	4	-	0.75	50	28	43	51
CPVF10-4	*174725	1000/2	5 x 15.1	1Am/M4	4	1	0.75/0.18	33/17	29	44	52
CPV 10-8	*173797	1000/1	7.1 x 20.5	1Am/M4	8	-	1.5	50	58	77	84
CPVF10-8	*173780	1000/1	7.1 x 20.5	1Am/M4	8	2	1.5/0.37	33/17	59	78	85
CPV 20-4	*174480	2000/2	7.1 x 20.5	1Am/M4	4	-	1.5	50	63	82	89
CPVF 20-4	*174459	2000/2	7.1 x 20.5	1Am/M4	4	1	1.5/0.37	33/17	64	83	90

\*Weight at standard lift (3 m). Other lifting heights on request.

\*\*For trolleys type A and B: Additional weight for geared trolley (VTG): 2.5 kg.

\*\*\*For electric trolley (VTE) with 2 speeds +2.0 kg.

\*\*\*\*Lifting speed CPV 10-8 at 230V. 1-phase. 50 Hz = 4 m/min. - Lifting speed CPV 20-4 at 230V. 1-phase. 50 Hz = 2 m/min.

### Festooned cable systems see page 144-145.



Increased operating safety through 42 V control voltage



Externally adjustable slip clutch.



Integrated limit switch



Depicted suspension hook and chain container optionally available.

Encapsulated pendant control. Option: radio remote control (in combination with integrated trolley).

## Technical data trolleys

Suitable for model	Capacity  kg	Size	Beam flange width b mm	Beam flange thickness t max. mm	Curve radius min.  m	Electric trolley travel speed m/min at 50 Hz	Electric trolley motor kW at 50 Hz
from CPV 2-8 up to CPVF 10-4	1000	A	58 - 180	19	0.9	18 or 18/4.5	0.18 or 0.18/0.06
from CPV 2-8 up to CPVF 10-4	1000	B	180 - 300	19	0.9	18 or 18/4.5	0.18 or 0.18/0.06
from CPV 10-8 up to CPVF 20-4	2000	A	58 - 180	19	1.15	18 or 18/4.5	0.18 or 0.18/0.06
from CPV 10-8 up to CPVF 20-4	2000	B	180 - 300	19	1.15	18 or 18/4.5	0.18 or 0.18/0.06
CPV/CPVF 5-20	2000	A	58 - 180	19	1.15	18 or 18/4.5	0.18 or 0.18/0.06
CPV/CPVF 5-20	2000	B	180 - 300	19	1.15	18 or 18/4.5	0.18 or 0.18/0.06



## Dimensions model CPV/CPVF

Model	CPV/CPVF 2-8	CPV/CPVF 5-4	CPV/CPVF 5-8 CPV/CPVF 2-20	CPV/CPVF 10-4	CPV/CPVF 10-8 CPV/CPVF 5-20	CPV/CPVF 20-4
A, mm	357	393	357	430	431	528
A1, mm	196	196	196	196	234	234
A2 (Size I), mm	476	476	476	476	564	564
A2 (Size II), mm	526	526	526	526	644	644
A2 (Size III), mm	606	606	606	606	734	734
A2 (Size IV), mm	798	798	798	798	934	934
B, mm	22	22	22	29	29	37
B1, mm	15	15	15	15	20	20
C, mm	29	29	29	35	35	40
C1, mm	38	38	38	38	45	45
C2, mm	105	105	105	105	154	154
D, mm	15	15	15	21	21	26
D1, mm	15	15	15	15	15	15
E, mm	277	277	277	277	326	326
G, mm	120	144	120	144	140	173
G1 (Size I), mm	142	166	142	166	175	208
G1 (Size II), mm	162	186	162	186	175	208
G1 (Size III), mm	162	186	162	186	175	208
G1 (Size IV), mm	162	186	162	186	175	208
H, mm	157	133	157	133	186	154
H2, mm	158	158	158	158	186	186
K (CPV), mm	208	208	208	208	285	285
K (CPVF), mm	208	208	208	208	285	285
M (Size I), mm	162	162	162	162	209	209
M (Size II), mm	197	197	197	197	209	209
M (Size III), mm	197	197	197	197	209	209
M (Size IV), mm	197	197	197	197	209	209
N*, mm	219	219	219	219	274	274

\*for 230V, 1-phase, 50Hz: +35 mm

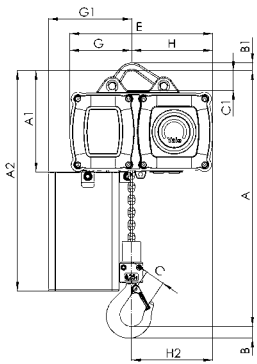

Model CPV/CPVF  
with suspension lug, 250 - 1000 kg, single fall

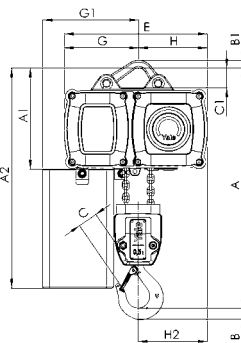
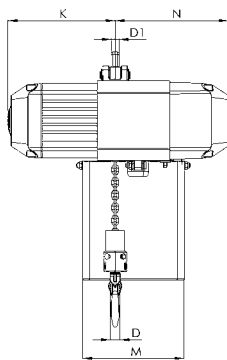

Model CPV/CPVF  
with suspension lug, 500 - 2000 kg, double fall

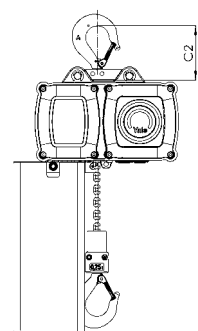
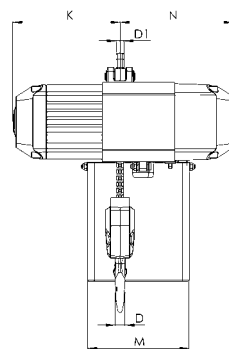

Model CPV/CPVF  
with suspension hook,  
250 - 2000 kg

## Dimensions model CPV/CPVF

Model	CPV/CPVF 2-8	CPV/CPVF 5-4	CPV/CPVF 5-8 CPV/CPVF 2-20	CPV/CPVF 10-4	CPV/CPVF 10-8 CPV/CPVF 5-20	CPV/CPVF 20-4
A3, mm	228	228	228	228	263	263
A4 (Size I), mm	508	508	508	508	593	593
A4 (Size II), mm	558	558	558	558	673	673
A4 (Size III), mm	638	638	638	638	768	768
A4 (Size IV), mm	830	830	830	830	968	968
A5, mm	389	425	389	462	460	558
b, mm	A = 50 - 180/ B = 180 - 300	A = 50 - 180/ B = 180 - 300	A = 50 - 180/ B = 180 - 300	A = 50 - 180/ B = 180 - 300	A = 50 - 180/ B = 180 - 300	A = 50 - 180/ B = 180 - 300
H1, mm	24	24	24	24	23	23
H3, mm	129	129	129	129	129	129
H4 (VTG), mm	95	95	95	95	95	95
H4 (VTE), mm	142	142	142	142	142	142
I (Pushed trolley), mm	72	72	72	72	96	96
I (Geared trolley), mm	77	77	77	77	98	98
L (VTP/VTG), mm	310	310	310	310	360	360
L1, mm	130	130	130	130	150	150
L2 (CPV), mm	255	255	255	255	255	255
L2 (CPVF), mm	263	263	263	263	263	263
L3, mm	155	155	155	155	180	180
L4, mm	161	161	161	161	203	203
O, mm	60	60	60	60	80	80
P, mm	200	200	200	200	200	200
P1, mm	246	246	246	246	246	246
S, mm	b + 50	b + 50	b + 50	b + 50	b + 54	b + 54
T, mm	94	94	94	94	94	94
tmax., mm	19	19	19	19	19	19

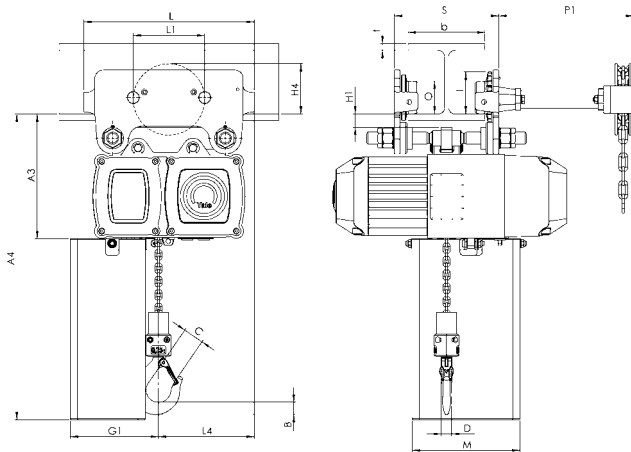

Model CPV/CPVF  
with integrated manual push or geared trolley

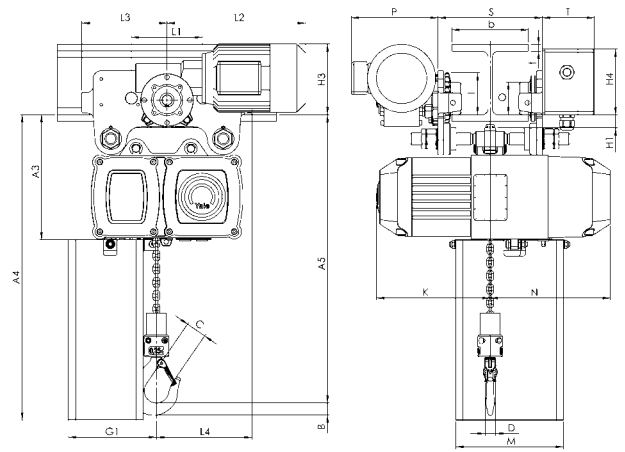

Model CPV/CPVF  
with integrated electric trolley



### Electric chain hoist model CPE with suspension hook or with integrated trolley

Capacity 1600 - 10000 kg

The CPE series is a range of high quality products for professional applications. They are highly efficient and engineered for a long working life. The hoists are composed of three main component parts which makes service easy and inexpensive.

#### Features

- Classification: 1 Am/M4, except models CPE(F) 20-8, CPE(F) 30-5 and CPE(F) 40-4 classification 1 Bm/M3. As required the model CPE (with appropriate changes to lifting capacity resp. duty cycle) can also be re-classified.
  - Direct control or 42V low voltage control.
  - 2 year warranty (excluding wear parts) as well as a lifetime lubricated gear box.
  - Motor fitted with a bimetallic thermal protection (useable in connection with low voltage control).
  - Duty cycle 40% at one operating speed.
  - The heavy duty squirrel cage motor has an adjustable spring pressure brake that holds the load secure even in the event of a power failure.
  - Standard operating voltage:  
Euro-voltage 400 Volt, 3-phase, 50 Hz.
  - Motor protected to IP 54, insulation class F, against ingress of dust and splashing. (acc. to VDE 0530)
  - Encapsulated pendant control protected to IP 65, against ingress of dust and water jets.
  - Up to 3000 kg only one chain fall, leading to a low overall height.
  - The 5-pocket load chain sheave, manufactured from wear resistant case hardening steel, is matched perfectly to the load chain to guarantee smooth and precise chain motion.
  - The standard, oil bath lubricated planetary gearbox is particularly smooth running.
  - Drop forged suspension and load hooks are made from non-aging, high tensile steel and fitted with robust safety latches.
  - The standard case hardened and zinc-plated link chain is matched perfectly to the load chain to guarantee smooth and precise chain motion.
- All requirements of national and international standards and regulations are fulfilled.

#### Options

- Stainless steel load chain.
- Suspension hook rotated 90°.
- Flexible chain container.
- Other operating voltages.
- Limit switches for highest and lowest hook positions (in combination with low voltage control).
- Motor with stainless steel brake.
- Radio remote control
- Control for synchronized operation of several hoists.
- Manual and electric trolleys.
- Integrated low headroom trolley.
- Connection to festooned cable systems.

## Twin hoist model CPE 100-2

### Capacity 10000 kg

The model CPE 100-2 consists of two CPE 50-2 units. They are connected by a framework. Hook suspension, geared or electric trolleys are available. Integrated limit switches for highest and lowest hook positions are standard. 42 V low voltage control as standard.

### Options

- Stainless steel load chain.
- Flexible chain container
- Other operating voltages
- Motor with stainless steel brake.
- Radio remote control
- Festooned cable system



**Festooned cable systems**  
see page 144-145.



5-pocket load chain sheave machined for smooth, precise chain motion.



Universal connection to suspension hook, trolley or steel structures.



Double fall bottom block for capacities between 3200 up to 5000 kg.



Hoist connected directly to trolley with electric drive. Manual pull and geared trolleys also available.



Option: Flexible chain container made from wear resistant textile fabric.

**The units are certified by the employer's liability insurance association (Berufsgenossenschaft) and fulfil the requirements of the machinery directive 2006/42/EG.**

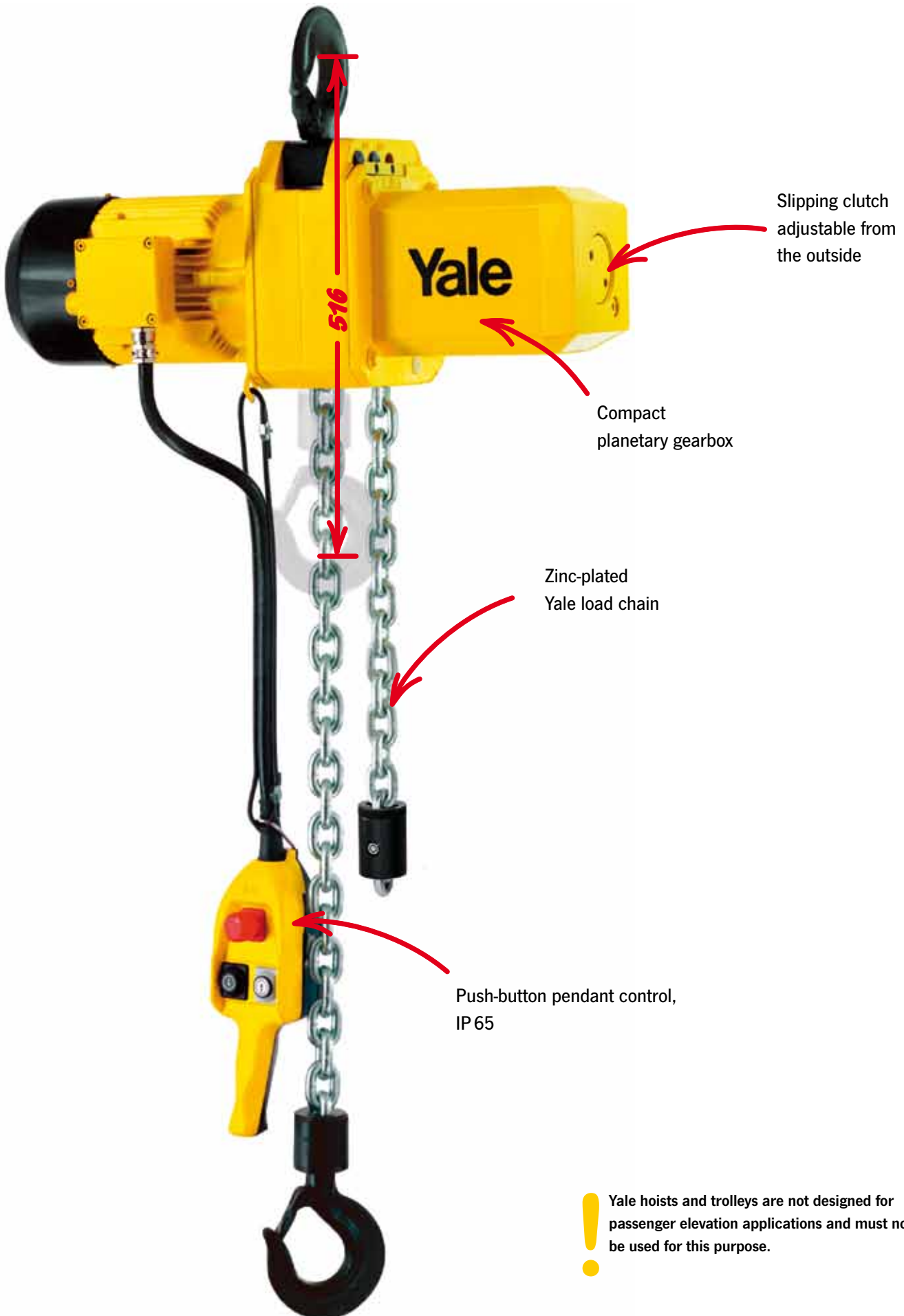

## Technical data model CPE/CPEF

Model	EAN-No. 4025092*	Capacity in kg/ number of chain falls	Chain dimensions d x p mm	Classification	Lifting speed main lift m/min	Lifting speed fine lift m/min	Hoist motor  kW	Motor rating  ED %
				FEM/ISO				
CPE 16-8	*073240	1600/1	11x31	1Am/M4	8	-	2.3	40
CPEF 16-8	*073257	1600/1	11x31	1Am/M4	8	2	2.3/0.58	40/20
CPE 20-8	*073264	2000/1	11x31	1Bm/M3	8	-	2.8	25
CPEF 20-8	*073271	2000/1	11x31	1Bm/M3	8	2	2.8/0.7	25/15
CPE 25-5	*073288	2500/1	11x31	1Am/M4	5	-	2.3	40
CPEF 25-5	*073295	2500/1	11x31	1Am/M4	5	1.25	2.3/0.58	40/20
CPE 30-5	*073301	3000/1	11x31	1Bm/M3	5	-	2.8	25
CPEF 30-5	*073318	3000/1	11x31	1Bm/M3	5	1.25	2.8/0.7	25/15
CPE 32-4	*073325	3200/2	11x31	1Am/M4	4	-	2.3	40
CPEF 32-4	*073332	3200/2	11x31	1Am/M4	4	1	2.3/0.58	40/20
CPE 40-4	*073349	4000/2	11x31	1Bm/M3	4	-	2.8	25
CPEF 40-4	*073356	4000/2	11x31	1Bm/M3	4	1	2.8/0.7	25/15
CPE 50-2	*073363	5000/2	11x31	1Am/M4	2.5	-	2.3	40
CPEF 50-2	*073370	5000/2	11x31	1Am/M4	2.5	0.6	2.3/0.58	40/20
CPE 75-1,6	*079907	7500/3	11x31	1Am/M4	1.6	-	2.8	40
CPEF 75-1,6	*079914	7500/3	11x31	1Am/M4	1.6	0.4	2.8/0.58	40/20
CPE 100-2	*060585	10000/4	11x31	1Am/M4	2.5	-	2x2.3	40
CPEF 100-2	*060592	10000/4	11x31	1Am/M4	2.5	0.6	2x2.3/0.58	40/20

Model	Weight* suspension hook kg	Weight* push trolley kg	Weight* geared trolley kg	Weight* electric trolley** kg
CPE 16-8	88	150	154	164
CPEF 16-8	93	155	159	169
CPE 20-8	88	150	154	164
CPEF 20-8	93	155	159	169
CPE 25-5	88	150	154	164
CPEF 25-5	93	155	159	169
CPE 30-5	88	150	154	164
CPEF 30-5	93	155	159	169
CPE 32-4	107	169	173	182
CPEF 32-4	112	174	178	187
CPE 40-4	107	169	173	182
CPEF 40-4	112	174	178	187
CPE 50-2	107	169	173	182
CPEF 50-2	112	174	178	187
CPE 75-1,6	-	-	-	-
CPEF 75-1,6***	-	-	-	-
CPE 100-2	282	-	385	406
CPEF 100-2***	287	-	390	411

\* Weight at standard lift (3 m). Other lifting heights on request.  
 \*\* Additional weight for 2 speed version 2,0 kg  
 \*\*\* Limit switches for highest and lowest hook positions – 42V low voltage control.

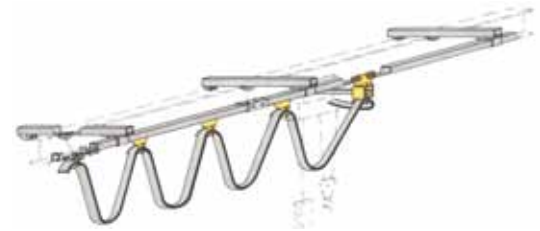

**Festooned cable systems**  
see page 144-145.



## Technical data trolleys

Capacity kg	Size	Beam flange width b mm	Beam flange thickness t max. mm	Curve radius min. m	Electric trolley travel speed m/min at 50 Hz	Electric trolley motor kW at 50 Hz
1600 - 5000	A	98 - 180	27	2.0	11 or 11/2.8	0.37 or 0.3/0.09
1600 - 5000	B	180 - 300	27	1.8	11 or 11/2.8	0.37 or 0.3/0.09
7500 - 10000	B	125 - 310	40	1.8	5 or 5/1.25	0.55 or 0.55/0.12



## Dimensions model CPE/CPEF

Model	CPE/CPEF 16-8	CPE/CPEF 20-8	CPE/CPEF 25-5	CPE/CPEF 30-5	CPE/CPEF 32-4	CPE/CPEF 40-4	CPE/CPEF 50-2	CPE/CPEF 75-1,6	CPE/CPEF 100-2
A, mm	516	516	516	516	681	681	681	950	1068
A1, mm	286	286	286	286	428	428	428	479	651
A2 (13 m), mm	430	430	430	430	430	430	430	-	-
A2 (21 m), mm	530	530	530	530	530	530	530	530	555
B, mm	35	35	35	35	45	45	45	60	60
C, mm	37	37	37	37	46	46	46	52	52
D, mm	24	24	24	24	30	30	30	40/45	40/45
E, mm	24	24	24	24	24	24	24	-	-
F1, mm	160	160	160	160	160	160	160	160	160
F2, mm	178	178	178	178	178	178	178	178	178
G, mm	220	220	220	220	220	220	220	220	-
G1, mm	180	180	180	180	140	140	140	268	315
G2 (13 m), mm	257	257	257	257	218	218	218	-	-
G2 (21 m), mm	277	277	277	277	238	238	238	345	408
H1, mm	110	110	110	110	110	110	110	110	135
H2, mm	135	135	135	135	135	135	135	307	256
K1, mm	100	100	100	100	100	100	100	92	92
K2, mm	51	51	51	51	51	51	51	62	62
M, mm	50	50	50	50	10	10	10	138	-
N, mm	84	84	84	84	124	124	124	136	390
Q1, mm	280	280	280	280	280	280	280	280	280
Q2 (CPE), mm	362	362	362	362	362	362	362	362	362
Q2 (CPEF), mm	417	417	417	417	417	417	417	417	417

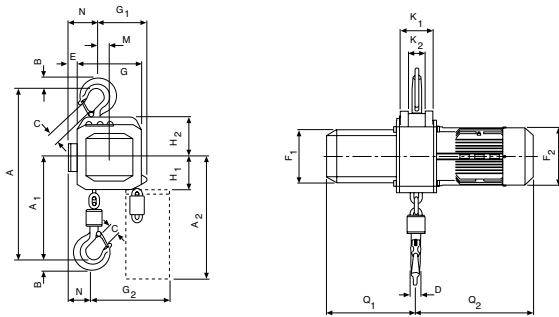

Model CPE/CPEF with suspension hook, 1600 - 3000 kg, single fall

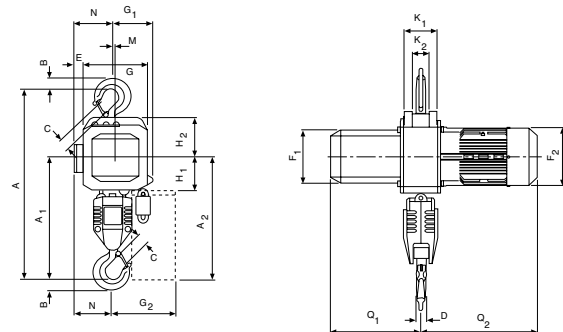

Model CPE/CPEF with suspension hook, 3200 - 5000 kg, double fall

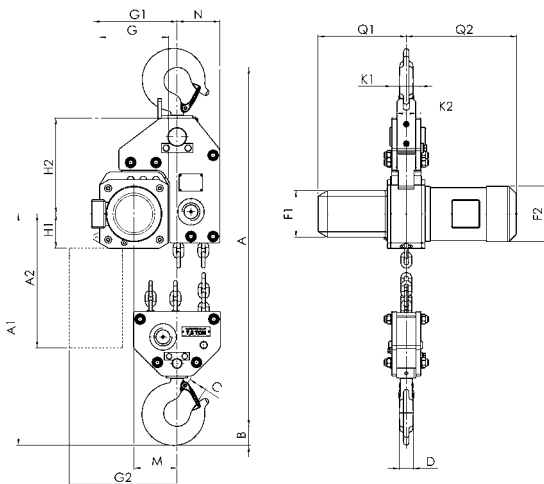

Model CPE/CPEF 75-1,6 with suspension hook, 7500 kg

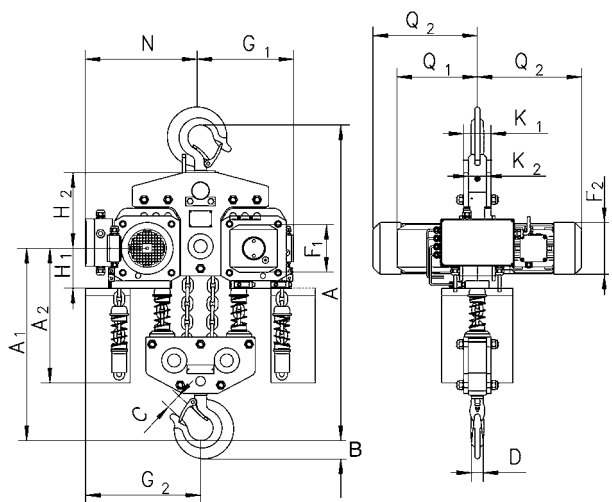

Model CPE/CPEF 100-2 with suspension hook, 10000 kg

## Dimensions model CPE/CPEF

Model	CPE/CPEF 16-8	CPE/CPEF 20-8	CPE/CPEF 25-5	CPE/CPEF 30-5	CPE/CPEF 32-4	CPE/CPEF 40-4	CPE/CPEF 50-2	CPE/CPEF 75-1,6	CPE/CPEF 100-2
A3, mm	121	121	121	121	121	121	121	-	110
A4, mm	465	465	465	465	615	615	615	855	965
A5, mm	298	298	298	298	298	298	298	477	450
A6, mm	178	178	178	178	178	178	178	-	170
b, mm	A = 98 - 180/ B = 180 - 300	A = 98 - 180/ B = 180 - 300	A = 98 - 180/ B = 180 - 300	A = 98 - 180/ B = 180 - 300	A = 98 - 180/ B = 180 - 300	A = 98 - 180/ B = 180 - 300	A = 98 - 180/ B = 180 - 300	125 - 310	125 - 310
F, mm	150	150	150	150	150	150	150	113	113
l, mm	142.5	142.5	142.5	142.5	142.5	142.5	142.5	170	170
L1, mm	209	209	209	209	209	209	209	200	200
L2, mm	262.5	262.5	262.5	262.5	262.5	262.5	262.5	215	215
L3 (VTE), mm	292	292	292	292	292	292	292	-	335
L3 (VTEF), mm	296	296	296	296	296	296	296	-	335
L4, mm	213	213	213	213	253	253	253	215	390
L5, mm	312	312	312	312	272	272	272	215	215
L6 (VTE), mm	342	342	342	342	342	342	342	-	-
L6 (VTEF), mm	346	346	346	346	306	306	306	-	-
O, mm	125	125	125	125	125	125	125	150	150
P (VTE), mm	197	197	197	197	197	197	197	-	273
P (VTEF), mm	205	205	205	205	205	205	205	-	280
P1, mm	229	229	229	229	229	229	229	-	110
S, mm	b + 70	b + 70	b + 70	b + 70	b + 70	b + 70	b + 70	b + 98	b + 98
T, mm	94	94	94	94	94	94	94	-	94
t max., mm	27	27	27	27	27	27	27	40	40

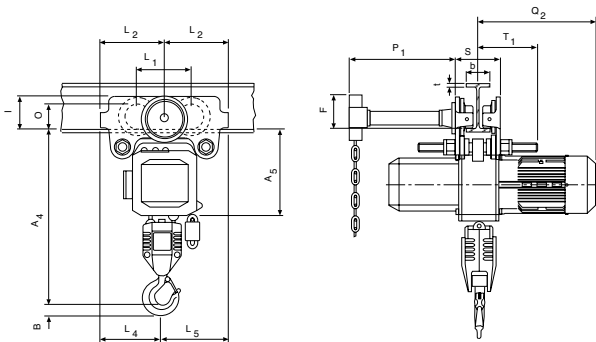

Model CPE/CPEF with integrated manual push or geared trolley

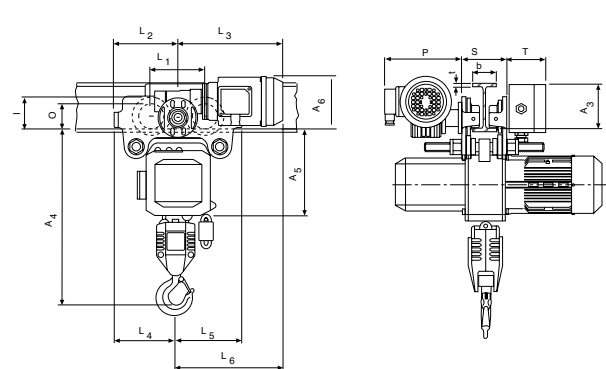

Model CPE/CPEF with integrated electric trolley

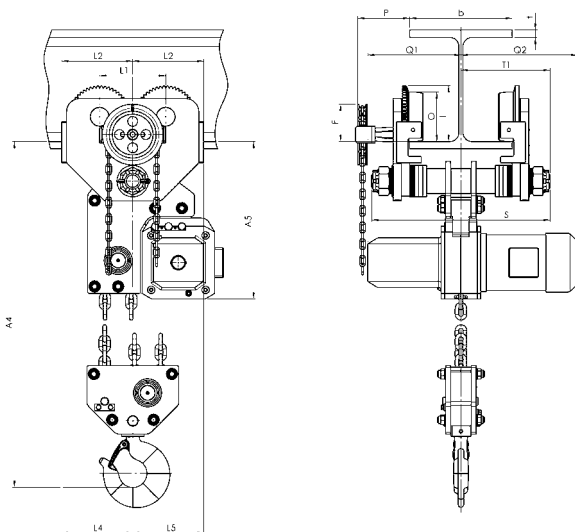

Model CPE/CPEF with integrated geared or electric trolley, 7500 kg

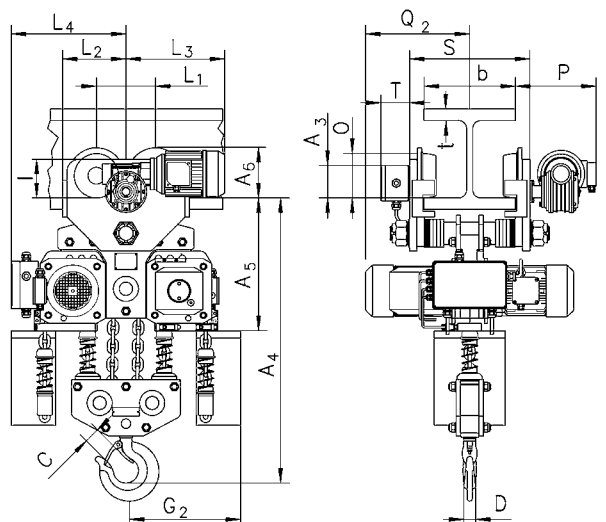

Model CPE/CPEF with integrated electric trolley, 10000 kg



Protection classification

Ex II 3 GD c IIB T4

! Also suitable for operation with nitrogen.

## Pneumatic chain hoist model CPA

Capacity 125 - 980 kg

Pneumatic chain hoists are characterized by high durability in a great number of industrial applications. The robust but light weight housing allows an easy transport.

### Features

- Designed for operating pressures of 5 to 7 bar.
- Rotating piston motor with 100% duty rating and an unlimited number of starts for continuous operation.
- Integrated limit switches for highest and lowest hook position as standard.
- Self-adjusting automatic disc brake, maintenance-free.
- Extremely sensitive control with emergency-stop for a precise positioning of the load
- Air release for brake as standard for models CPA 2-31, CPA 5-17 and CPA 10-9
- Chain container as standard

### Options

- Manual and powered trolleys with shackle to fit top hook suspended pneumatic chain hoists.
- All models available with push or geared trolley
- Models CPA 2-31, CPA 5-17 and CPA 10-9 also available with pneumatic trolleys
- Models CPA 2-31, CPA 5-17 and CPA 10-9 also available for operation in hazardous areas, category 2 (Zone 1/21)
- Models CPA 2-31, CPA 5-17 and CPA 10-9 also available with chain control
- Maintenance unit for main air supply pipe (pressure regulator, manometer, lubricator and support)

### Applications

Automobile and aircraft industries, shipyards, on ships and docks. Foundries, on-/offshore, paint factories and paint shops, refineries, oil depots, galvanizing. Printing, textile and food industries, pulp, paper and cement mills. Glass and ceramic industries, wood working industries, chemical industries, heat treatment and power plants etc.

! To ensure faultless operation the compressed air supply must be filtered and oiled.

## Technical data model CPA

Model	EAN-No. 4025092*	Capacity in kg/ number of chain falls	Lifting speed with rated load* m/min.	Lifting speed without load* m/min.	Lowering speed with rated load* m/min.	Air consumption with rated load* m <sup>3</sup> /min.	Hoist motor  kW	Weight at 3 m lift  kg
CPA 1-13	*911795	125/1	13.1	17.1	11.3	0.9	0.4	15.4
CPA 2-10	*911788	250/1	9.8	17.1	13.7	0.9	0.4	15.4
CPA 2-31	*911801	250/1	31.0	52.0	36.0	1.98	1.33	21.8
CPA 5-5	*911818	500/2	4.6	7.9	6.7	0.9	0.4	17.2
CPA 5-17	*911825	500/1	16.8	32.3	29.6	1.27	1.33	21.8
CPA 10-9	*911832	980/2	8.5	16.2	14.9	1.27	1.33	27.7

\*Values for 6.3 bar (flow pressure) and 2 m control drop. Speeds will be reduced in case of longer control length. Hose length max. 12 m. Model CPA 1-13, CPA 2-10 and CPA 5-5 hose length max. 12 m, Model CPA 2-31, CPA 5-17 and CPA 10-9 hose length max. 20 m.

## Dimensions model CPA

Model	CPA 1-13	CPA 2-10	CPA 2-31	CPA 5-5	CPA 5-17	CPA 10-9
A, mm	292	292	457	324	457	457
A1, mm	410	410	483	410	483	508
B, mm	21	21	25	14	25	27
C, mm	20	20	24	24	24	28
D, mm	16	16	26	14	26	28
F1, mm	90	90	130	90	130	130
F2, mm	120	120	180	120	180	180
K, mm	103	103	146	103	146	165
L, mm	57	57	102	57	102	83
M, mm	120	120	114	120	114	135
N, mm	50	50	54	50	54	25
Q1, mm	142	142	162	142	162	162
Q2, mm	183	183	181	183	181	181

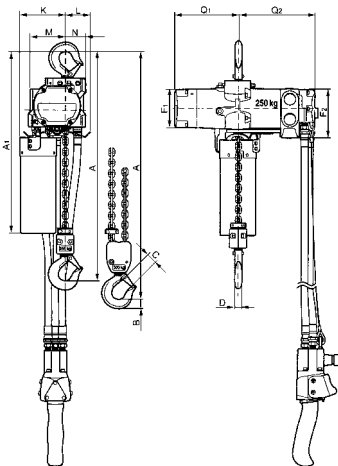

Model CPA 1-13 / 2-10 / 5-5

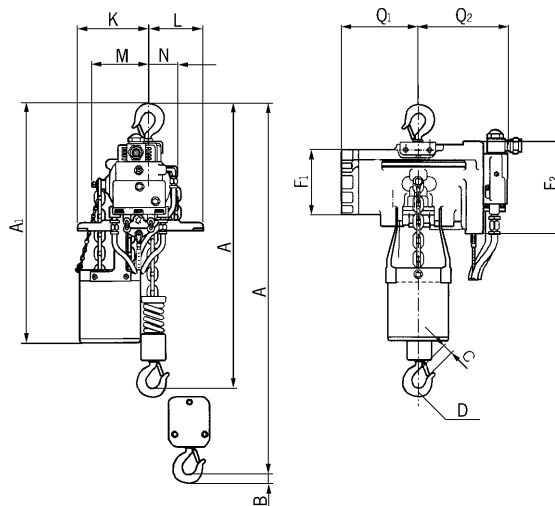

Model CPA 2-31 / 5-17 / 10-9



### Pneumatic chain hoist model CPA with suspension hook or with integrated trolley

Capacity 2000 - 10000 kg

The conception is in accordance with the design of the model CPE.

With 100% duty rating and an unlimited number of starts the model CPA is suitable for heavy duty applications. It is insusceptible to contamination, humidity and aggressive mediums from the outside. The hoists are composed of three main components which makes service easy and inexpensive.

#### Features

- Designed for operating pressures of 4 to 6 bar.
  - Robust rotating piston motor has an adjustable spring pressure brake that holds the load secure even in the event of an air failure.
  - The standard, oil bath lubricated planetary gearbox is particularly smooth running and enables a low overall height.
  - High starting torque due to switching valves in the motor body.
  - Low noise emission due to large dimension silencer.
  - Sensitive control by means of 2 resp. 4 button pendant control with emergency-stop.
  - Up to 3000 kg only one chain fall, leading to a low overall height.
  - The 5-pocket load chain sheave, manufactured from wear resistant case hardening steel, is matched perfectly to the load chain to guarantee smooth and precise chain motion.
  - Drop forged suspension and load hooks are made from non-aging, high tensile steel and fitted with robust safety latches.
  - The standard case hardened and zinc-plated link chain is matched perfectly to the load chain to guarantee smooth and precise chain motion.
- All requirements of national and international standards and regulations are fulfilled.

#### Options

- Manual and pneumatic trolleys.
- Rope control
- Stainless steel load chain.

**To ensure faultless operation  
the compressed air supply must be  
filtered and oiled.**

## Technical data model CPA

Model	EAN-No. 4025092*	Capacity in kg/ number of chain falls	Lifting speed with rated load* m/min	Lifting speed without load* m/min	Lowering speed with rated load* m/min	Hoist motor kW	Weight** suspension hook kg	Weight** push trolley kg	Weight** geared trolley kg	Weight** pneumatic trolley kg
CPA 20-8	*073868	2000/1	7.4	9.9	11.0	2.6	121	184	188	199
CPA 30-6	*073875	3000/1	6.0	9.9	13.0	3.2	121	184	188	199
CPA 40-4	*073882	4000/2	3.7	5.0	5.5	2.6	140	202	206	218
CPA 50-3	*073899	5000/2	3.4	5.0	6.0	3.0	140	202	206	218
CPA 60-3	*073905	6000/2	3.0	5.0	6.5	3.2	140	202	206	218
CPA 75-2	*056915	7500/3	2.0	3.3	4.3	3.2	-	-	-	-
CPA 100-2	*075701	10000/4	3.4	5.0	6.0	2x3.0	-	-	-	-

\*Values for 6 bar (flow pressure), air consumption with rated load 4.7 m<sup>3</sup>/min. CPA 100-2: 9.4 m<sup>3</sup>/min.

\*\*Weight at standard lift (3 m). Other lifting heights on request.



Application with pneumatic trolley

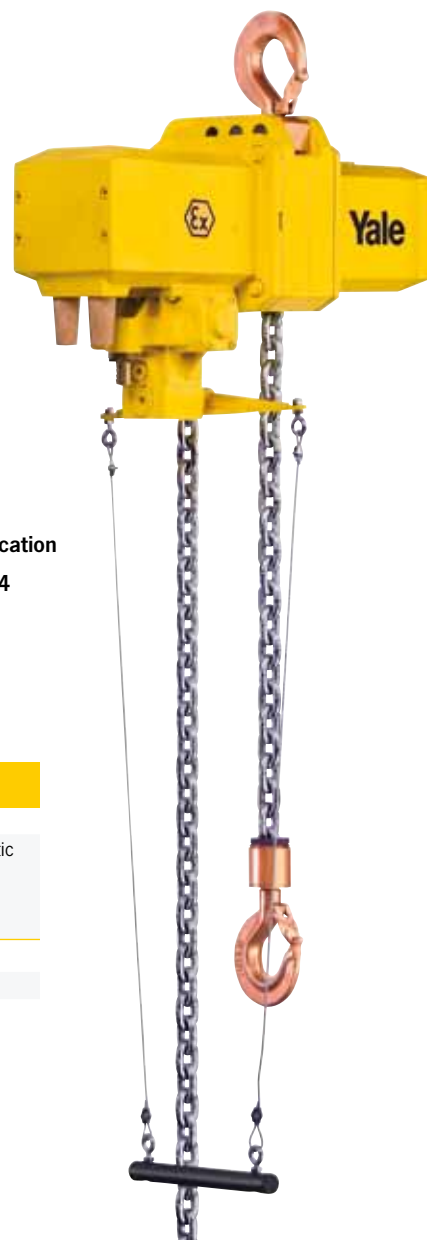

Protection classification

II 2 GD c IIB T4

## Technical data trolleys

Capacity kg	Size	Beam flange width b mm	Beam flange thickness t max. mm	Curve radius min. m	Pneumatic trolley travel speed m/min	Pneumatic trolley motor kW
2000 - 6000	A	98 - 180	27	2.0	18	0.55
2000 - 6000	B	180 - 300	27	1.8	18	0.55
7500 - 10000	B	125 - 310	40	1.8	-	-

Other capacities on request.



## Dimensions model CPA

Model	CPA 20-8	CPA 30-6	CPA 40-4	CPA 50-3	CPA 60-3	CPA 75-2	CPA 100-2
A, mm	516	516	681	681	681	950	1068
A1, mm	286	286	428	428	428	479	651
B, mm	35	35	45	45	47	60	60
C, mm	37	37	46	46	42	52	52
D, mm	24	24	30	30	30	40/45	40/45
F1, mm	160	160	160	160	160	160	160
F2, mm	165	165	165	165	165	165	165
G, mm	220	220	220	220	220	220	581
G1, mm	180	180	140	140	140	268	311
G2 (13 m), mm	258	258	218	218	218	-	-
G2 (21 m), mm	278	278	238	238	238	345	408
H1, mm	110	110	110	110	110	110	110
H2, mm	135	135	135	135	135	307	256
H3, mm	115	115	115	115	115	115	115
K1, mm	100	100	100	100	100	92	92
K2, mm	51	51	51	51	51	62	62
M, mm	50	50	9.6	9.6	9.6	139	181
N, mm	60	60	100	100	100	136	291
Q1, mm	272	272	272	272	272	272	272
Q2, mm	325	325	325	325	325	325	325

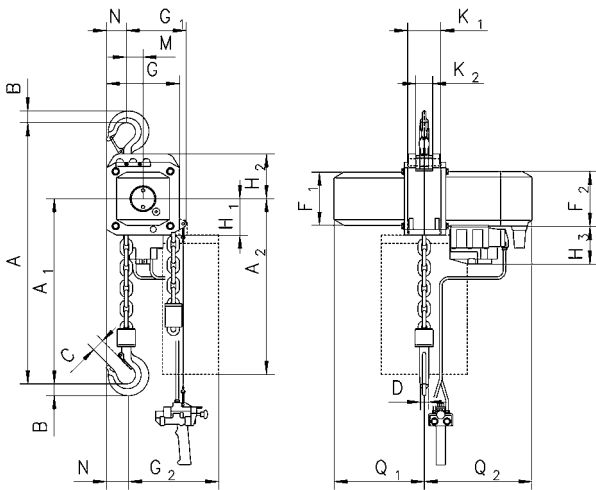

Model CPA with suspension hook, 2000 - 3000 kg, single fall

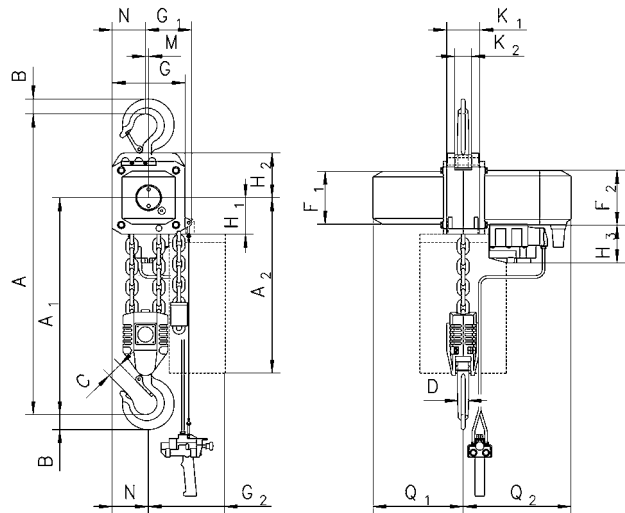

Model CPA with suspension hook, 4000 - 6000 kg, double fall

## Dimensions model CPA

Model	CPA 20-8	CPA 30-6	CPA 40-4	CPA 50-3	CPA 60-3	CPA 75-2	CPA 100-2
A2 (13 m), mm	430	430	430	430	430	-	-
A2 (21 m), mm	530	530	530	530	530	530	530
A4, mm	465	465	615	615	615	855	965
A5, mm	298	298	298	298	298	477	425
A6, mm	190	190	190	190	190	182	182
b, mm	A = 98 - 180/ B = 180 - 300	A = 98 - 180/ B = 180 - 300	A = 98 - 180/ B = 180 - 300	A = 98 - 180/ B = 180 - 300	A = 98 - 180/ B = 180 - 300	125 - 310	125 - 310
F, mm	150	150	150	150	150	113	113
I, mm	142.5	142.5	142.5	142.5	142.5	130	130
L1, mm	209	209	209	209	209	200	200
L2, mm	262.5	262.5	262.5	262.5	262.5	215	215
L3, mm	265	265	265	265	265	265	265
L4, mm	213	213	253	253	253	291	291
L5, mm	312	312	272	272	272	-	-
L6, mm	315	315	275	275	275	-	-
O, mm	125	125	125	125	125	150	150
P, mm	208	208	208	208	208	208	208
P1, mm	284	284	284	284	284	284	284
S, mm	b + 70	b + 70	b + 70	b + 70	b + 70	b + 98	b + 98
t, mm	27	27	27	27	27	40	40
T1 size A	182	182	182	182	182	-	-
T1 size B	242	242	242	242	242	270	270

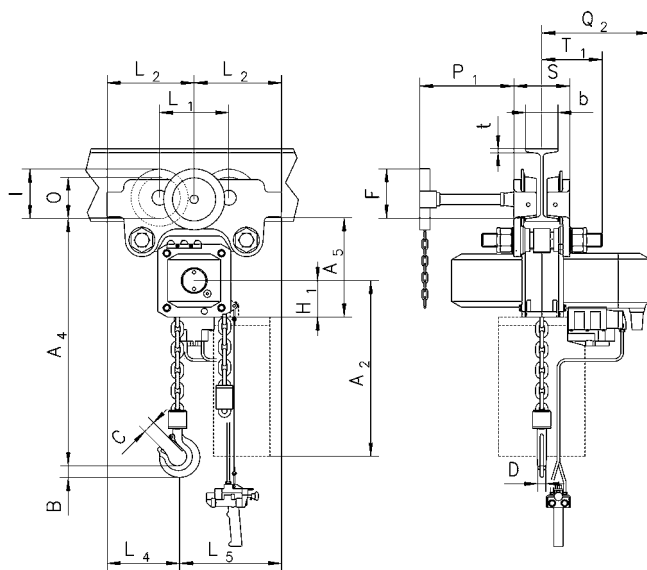

Model CPA with integrated manual push or geared trolley

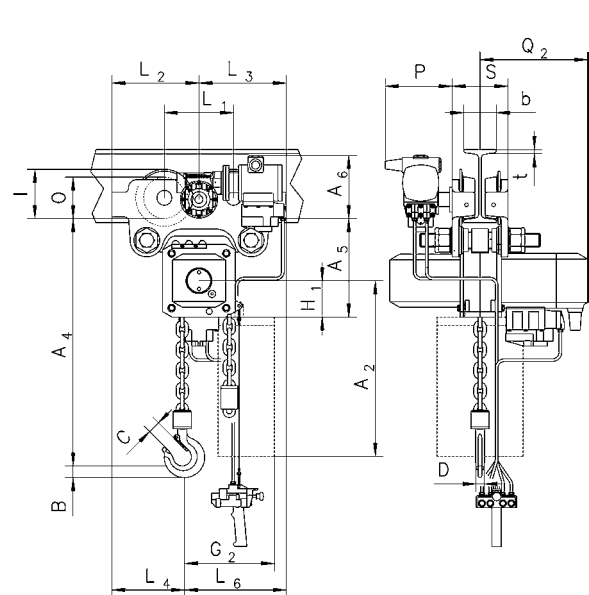

Model CPA with integrated pneumatic trolley

## Yale link chains, zinc-plated

for	EAN-No. 4025092*	Capacity in kg/ number of chain falls	Chain dimensions d x p mm	Chain stop	
Model D85	*050920	750/1	6 x 18.5	•	
	*050937	1500/1	9 x 27	•	
	*050951	3000/1	11 x 31	•	
	*050951	6000/2	11 x 31	•	
	*050951	10000/3	11 x 31	•	
Model D95	*051002	1500/1	6.2 x 18.5	•	
	*051422	3000/1	9 x 27.2	•	
Model AL	*051323	750/1	6.3 x 19.1	•	
	*051323	1000/1	6.3 x 19.1	•	
	*051347	1500/1	7.1 x 21.2	•	
	*051378	3000/1	10 x 30.2	•	
Model PT	*051415	800/1	5.6 x 17.1	–	
	*051347	1600/1	7.1 x 21.2	•	
	*051422	3200/1	9 x 27.2	•	
	*051422	6300/2	9 x 27.2	•	
Model UNOplus	*053846	750/1	6 x 18	•	
	*053860	1500/1	8 x 24	•	
	*053884	3000/1	10 x 30	•	
	*053884	6000/2	10 x 30	•	
Model Yalehandy	*051316	250/1	4 x 12	–	
	*051316	500/1	4 x 12	–	
Model Yalelift 360	*075244	500/1	5 x 15	–	
	*053846	1000/1	6 x 18	•	
	*053860	2000/1	8 x 24	•	
	*053884	3000/1	10 x 30	•	
	*053884	5000/2	10 x 30	•	
	*077002	10000/3	10 x 30	•	
	*077002	20000/6	10 x 30	•	
	Model VSplus	*053846	500/1	6 x 18	•
		*053846	1000/1	6 x 18	•
		*053846	2000/2	6 x 18	•
*053860		2000/1	8 x 24	•	
*053860		3000/2	8 x 24	•	
*053884		3000/1	10 x 30	•	
*053884		5000/2	10 x 30	•	
Model CPS	*076074	125 - 250/1	4 x 12.2	–	
	*076074	500/2	4 x 12.2	–	
Model CPV	*076074	250/1	4 x 12.2	–	
	*076074	500/2	4 x 12.2	–	
	*081030	500/1	5 x 15.1	–	
	*081030	1000/2	5 x 15.1	–	
	*081047	1000/1	7.1 x 20.5	•	
Model CPE/CPA	*081047	2000/2	7.1 x 20.5	•	
	*079389	125 - 250/1	4 x 12	–	
	*079396	500 - 990/1	7 x 21	•	
	*056489	1600 - 3000/1	11 x 31	•	
	*056489	3200 - 5000/2	11 x 31	•	
	*056489	7500/3	11 x 31	•	
	*056489	10000/4	11 x 31	•	

## Yale roller chains

for	EAN-No. 4025092*	Capacity in kg/ number of chain falls	Chain dimensions d x p Inch	Chain stop
Model C85	*050449	750/1	5/8" x 3/8"	on request
	*050456	1500/1	1" x 1/2"	on request
	*050463	3000/1	1 1/4" x 5/8"	on request
	*050463	6000/2	1 1/4" x 5/8"	on request
	*050463	10000/3	1 1/4" x 5/8"	on request

## Yale chain stop for link chains model YKST

Yale chain stops have been developed for Yale hoists with round-section steel chains as an additional protection against falling.

The two available sizes cover two different ranges of chain sizes.

The load capacity indicated on the chain stop is the maximum working load limit (rated load) that must not be exceeded by the respective hoist used.

The chain stop can be moved along the load chain of the hoist by actuating the safety device and pressing the slider at the same time. When the slider is released, it automatically locks in the load chain and the safety lock blocks the system.

In order to ensure safe functioning of the chain stop, the distance between the chain stop and the hoist must not exceed 15 - 20 mm. After the use of the hoist, the chain stop must be repositioned, as required.



Model	Suitable for chain mm	Capacity WLL kg	Dimensions L x W x D mm	Weight kg
YKST 16	5.6 - 8	1600	75 x 56 x 15	0.35
YKST 32	9 - 11	3200	105 x 82 x 24	1.15

**The use for different chain dimensions is not permitted.**



### Yale link chains, stainless steel

for	EAN-No. 4025092*	Capacity in kg/ number of chain falls	Capacity max. per chain hoist kg	Chain dimensions d x p mm	Chain stop
Model D85	*050944	1500/1	1500	9x27	•
Model D95	on request	1500/1	–	6.2x18.5	•
Model AL	*051330	750/1	750	6.3x19.1	•
	*051330	1000/1	1000	6.3x19.1	•
	*051354	1500/1	1250	7.1x21.2	•
	*051385	3000/1	2000	10x30.2	•
Model PT	*051354	1600/1	1250	7.1x21.2	•
Model UNOplus	*053853	750/1	750	6x18	•
	*053877	1500/1	1250	8x24	•
	*053891	3000/1	2000	10x30	•
	*053891	6000/2	4000	10x30	•
Model Yalelift 360	*058506	500/1	500	5x15	–
	*053853	1000/1	900	6x18	•
	*053877	2000/1	1250	8x24	•
	*053891	3000/1	2000	10x30	•
	*053891	5000/2	4000	10x30	•
Model VSplus	*053853	500/1	500	6x18	•
	*053853	1000/1	900	6x18	•
	*053853	2000/2	1800	6x18	•
	*053877	2000/1	1250	8x24	•
	*053877	3000/2	2500	8x24	•
	*053891	3000/1	2000	10x30	•
	*053891	5000/2	4000	10x30	•
Model CPV	*077330	250/1	250	4x12.2	–
	*077330	500/2	500	4x12.2	–
	*166546	500/1	500	5x15.1	–
	*166546	1000/2	1000	5x15.1	–
	*166553	1000/1	1000	7.1x20.5	•
	*166553	2000/2	2000	7.1x20.5	•
Model CPA	*221498	125/1	125	4x12	–
	*080415	500/1	500	7x21	•
Model CPE/CPA	*056410	1600/2000/1	1600/2000	11x31	•
	*056410	2500/3000/1	2000	11x31	•
	*056410	3200/4000/2	3200/4000	11x31	•
	*056410	5000/2	4000	11x31	•
	*056410	7500/3	6000	11x31	•
	*056410	10000/4	8000	11x31	•

### Yale hand chains, zinc-plated

for model	EAN-No. 4025092*	Chain dimensions d x p in mm
HTG, VSplus, CPV, CPE, CPA, Yalelift 360	*053907	5x26
Connection link for hand chain	*014946	5x26

### Yale hand chains, stainless steel

for model	EAN-No. 4025092*	Chain dimensions d x p in mm
HTG, VSplus, CPV, CPE, CPA, Yalelift 360	*053914	5x26
Connection link for hand chain	*955690	5x26



Model LB, zinc-plated version  
Capacity 1.200 kg

Model LB, zinc-plated version  
Capacity 350 kg

## Console-mounted winch model LB

Capacity 150 - 1200 kg

Originally developed as offroad winch the console-mounted winch model LB is used today for a variety of lifting and pulling applications.

### Features

- Light weight robust stamped steel housing.
- Spur gear drive for optimal efficiency and comfortable handling.
- Automatic load pressure brake for save holding of the load in any position. An unintentional brake release is prevented.
- All parts are zinc-plated for increased corrosion protection, drum with additional special coating.
- Easy and quick mounting to consoles, even under lifting conditions.

### Options

- Stainless steel version (mat. 1.4301) for increased corrosion protection.
- Free wheeling device for a quick manual unrolling of the unloaded rope.
- Variable crank with adjustable crank handle.
- Foldable crank with tiltable handle for use in confined spaces.



Model LB-VA, stainless steel version  
Capacity 900 kg



Option: Foldable crank  
with tiltable handle for use  
in confined spaces.

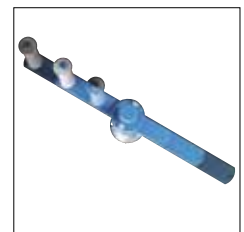

Option: Variable crank  
with adjustable crank  
handle.

## Technical data model LB

Model	Art.-No. Zinc-plated version	Art.-No. Free wheeling device	Art.-No. Stainless steel version	Capacity 1 <sup>st</sup> layer kg	Capacity top layer kg	Rope diameter mm	Useable rope length 1 <sup>st</sup> layer m	Useable rope length max. m	Lift per crank rotation mm	Required crank effort daN	Weight without rope kg
LB 150 VZ	030239016	-	-	150	75	4*	0.8	11	125	17	4.2
LB 350 VZ	030239015	-	-	350	170	4*	1.8	20	125	25	4.8
LB 650 VZ	040239004	-	-	650	290	6*	1	20	55	22	7.3
LB 900 VZ/ARA	040239006	040239007	-	900	400	7*	0.8	14	58	24	10
LB 1200 VZ/ARA	040239008	040239009	-	1200	430	7**	1	26	45	24	12.1
LB 250 VA	-	-	030239017	250	125	4*	1.8	19.5	125	20	4.8
LB 650 VA	-	-	040239012	650	290	6*	1	20	55	22	7.6
LB 900 VA	-	-	030239013	900	320	7*	1	26	45	24	12.1

\*recommended rope: DIN 3060 FE-znk 1770 sZ-spa

\*\*recommended rope: DIN 3060 SE-znk 2160 sZ-spa

## Dimensions model LB

Model	LB 150 VZ	LB 350 VZ	LB 650 VZ	LB 900 VZ LB 900 ARA	LB 1200 VZ LB 1200 ARA	LB 250 VA	LB 650 VA	LB 900 VA
Art.-No. Zinc-plated version	030239016	030239015	040239004	040239006	040239008	-	-	-
Art.-No. Free wheeling device	-	-	-	040239007	040239009	-	-	-
Art.-No. Stainless steel version	-	-	-	-	-	030239017	040239012	030239013
A, mm	-	-	232	232	273	-	232	273
B, mm	155	155	192	192	266	155	192	266
C, mm	175	175	210	210	240	175	210	240
Ø D, mm	36	36	63.5	63.5	63.5	36	63.5	63.5
Ø E, mm	100	100	183	183	255	100	183	255
F, mm	-	-	100	100	78	-	100	78
G, mm	75	75	58	58	75	75	58	75
H, mm	-	-	100	100	138	-	100	138
K, mm	159	189	192	192/226*	192/226*	191.5	190	190
L, mm	-	-	25	25	35	-	25	35
M, mm	45	75	38	38	30	75	38	30
N, mm	-	-	-	-	53	-	-	53
O, mm	200	320	250	320	320	320	250	250
P, mm	260	290	293	293/303*	293/303*	292.5	291	291
Q, mm	81	111	95	95	95	111	95	95
R, mm	50	80	50	50	50	80	50	50
S, mm	48	63	55	55	55	65.5	55	55

\*Free wheeling device

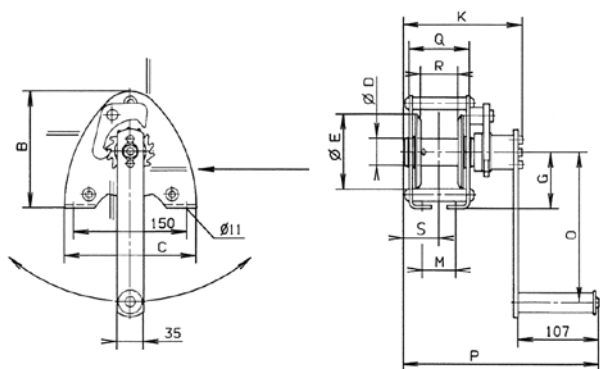

Model LB 150 - 350 kg

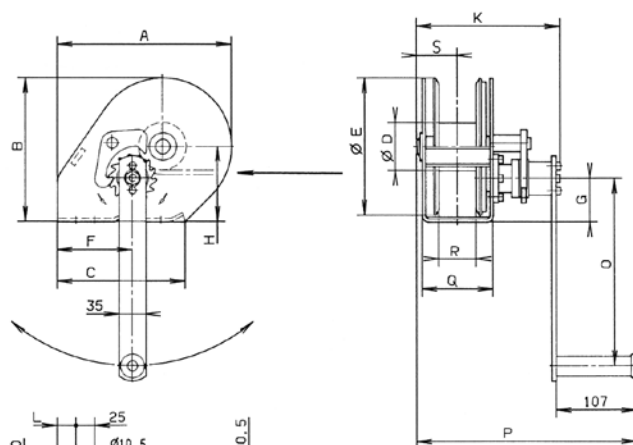

Model LB 650 - 1200 kg





80 - 125 kg

300 - 750 kg

## Wall-mounted winch model SW-W

Capacity 80 - 750 kg

Wall-mounted rope winches of the SW-W model range are intended for fixed stationary mounting inside a building. The steel wire rope is guided to the required suspension point of the load by means of deflection sheaves.

### Features

- Robust aluminium housing for models SW-W 80 and SW-W 125, proven steel plate design for models SW-W 300 - 750.
- Spur gear drive for optimal efficiency and comfortable handling. Direct drive for loads up to 125 kg.
- The low-noise safety spring brake safely holds the load in every position.
- Removable hand crank for models SW-W 80 and SW-W 125, foldable crank for models SW-W 300 - 750.
- Easy and quick mounting onto walls.

### Options

- Safety retaining spring with removable hand crank.

## Technical data model SW-W

Model	Art.-No.	Capacity 1 <sup>st</sup> layer kg	Capacity top layer kg	Drum diameter mm	Rope diameter mm	Useable rope length 1 <sup>st</sup> layer m	Useable rope length top layer m	Lift per crank rotation mm	Required crank effort daN	Weight without rope kg
SW-W 80	040271017	80	45	51	3*	2.4	30	170	12	3
SW-W 125	040271008	125	65	40	4*	2	12	138	13	3
SW-W 300	030271001	300	220	108	5**	2.1	15	68	15	10
SW-W 500	030271136	500	350	108	6**	2.4	15	35	13	11
SW-W 750	030271019	750	550	108	7**	2	10	35	20	11

\*recommended rope: DIN 3055 FE-znk 1770 sZ-spa

\*\*recommended rope: DIN 3060 FE-znk 1770 sZ-spa

## Dimensions model SW-W

Model	SW-W 80	SW-W 125	SW-W 300	SW-W 500	SW-W 750
Art.-No.	040271017	040271008	030271001	030271136	030271019
A, mm	110	110	250	250	250
B, mm	110	110	250	250	250
C, mm	130	130	290	290	290
D, mm	130	130	290	290	290
Ø E, mm	9	9	14.5	14.5	14.5
F, mm	15	15	2	2	2
H, mm	121	121	85	85	85
I, mm	55	55	138	138	138
J, mm	-	-	117	117	117
K, mm	250	250	250	250	250
L, mm	130	130	130	130	130
M, mm	68	68	39	39	39
O, mm	60	60	50	50	50
P, mm	275	275	192	192	192

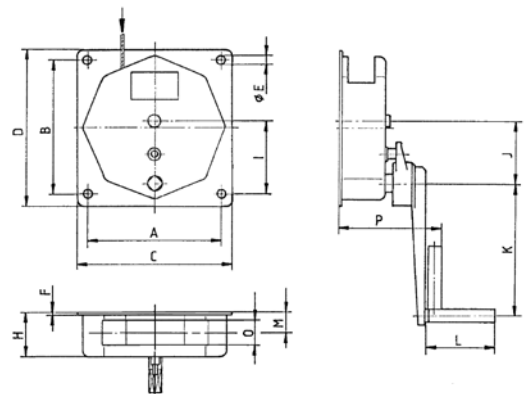

## Wall-mounted winch model SW-W ALPHA

Capacity 300 - 1000 kg

A versatile wall-mounted winch for an easy lifting of loads.

### Features

- Light weight robust stamped steel housing and compact design.
- Spur gear drive for optimal efficiency and comfortable handling.
- Rope lead-offs to all directions.
- All parts are zinc-plated for increased corrosion protection, drum with additional special coating.
- Integrated crank with load pressure brake for safe holding of the load.
- Easy and quick mounting onto walls.

### Options

- Foldable crank with tiltable handle for use in confined spaces.
- Variable crank with adjustable crank handle.



Option: Foldable crank with tiltable handle for use in confined spaces.

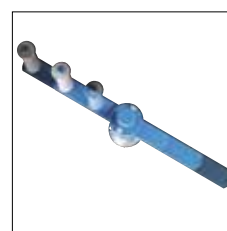

Option: Variable crank with adjustable crank handle.

## Technical data model SW-W ALPHA

Model	Art.-No.	Capacity 1 <sup>st</sup> layer kg	Capacity top layer kg	Drum length mm	Rope diameter* mm	Useable rope length 1 <sup>st</sup> layer m	Useable rope length top layer m	Lift per crank rotation mm	Required crank effort daN	Weight without rope kg
ALPHA 300	030272006	300	130	50	5	1.3	28	57	13	10
ALPHA 500	030272005	500	230	50	6	1	20	55	17	10
ALPHA 750	030272002	750	270	50	7	1	26	45	17	16
ALPHA 1000	030272001	1000	360	50	7	1	26	45	18	16

\*recommended rope: DIN 3060 FE-znk 1770 sZ-spa

## Dimensions model SW-W ALPHA

Model	ALPHA 300	ALPHA 500	ALPHA 750	ALPHA 1000
Art.-No.	030272006	030272005	030272002	030272001
A, mm	234	234	306	306
B, mm	262	262	337	337
C, mm	274	274	357	357
D, mm	203	203	265	265
E, mm	107	107	107	107
F, mm	194	194	194	194
G, mm	183	183	255	255
H Ø, mm	63	63	63.5	63.5
I, mm	200	250	250	320
J, mm	58.6	58.6	92.5	92.5
K, mm	109.5	109.5	107	107

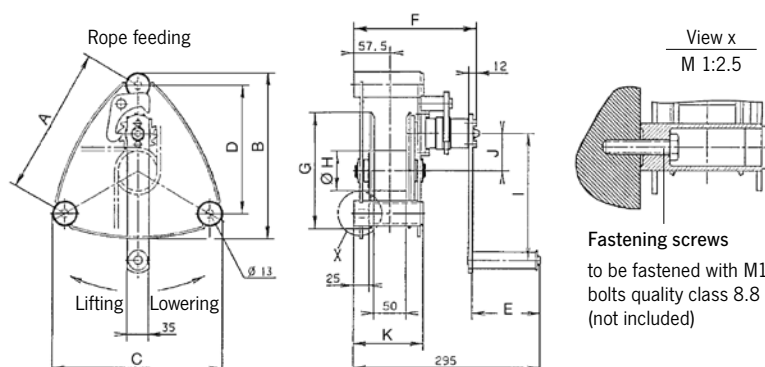



## Wall-mounted winch with worm gear drive model SW-W-SGG

Capacity 250 - 750 kg

The robust manual rope winches with enclosed worm gear are used in the agricultural industry and in the marine sector.

### Features

- Winch housing with enclosed worm gear and additional load pressure brake of solid casting design for a long service life.
- The oil bath lubricated worm gear ensures quiet running characteristics.
- Easy and quick mounting.
- The crank arm is adjustable and makes it possible to work faster with small loads.

### Options

- Special paint finish for improved corrosion protection
- Foldable crank with tiltable handle for use in confined spaces.
- Grease lubrication – for modified mounting position
- Grooved rope drum for improved guidance of the rope.
- Drum with separation web for operation with several ropes.

### Technical data model SW-W-SGG

Model	Art.-No.	Capacity 1 <sup>st</sup> layer kg	Capacity top layer kg	Drum diameter mm	Rope diameter* mm	Useable rope length 1 <sup>st</sup> layer m	Useable rope length top layer m	Lift per crank rotation mm	Required crank effort daN	Weight without rope kg
SGG 250	030242004	250	210	96	5	4.8	17.9	20	9.2	12
SGG 500	030243000	500	425	125	6	8.1	28.8	26	14.5	22
SGG 750	030244007	750	624	150	8	9.2	48	20	16	43

\*recommended rope: DIN 3060 FE-znk 1770 sZ-spa

### Technical data model SW-W-SGG

Model	SGG 250	SGG 500	SGG 750
Art.-No.	030242004	030243000	030244007
A, mm	205	250	330
B, mm	137	190	243
C, mm	120	150	205
D, mm	85	100	125
Ø E, mm	135	182	240
F, mm	219	282	350
G, mm	94	138	182
Ø H, mm	96	125	150
J, mm	310	476	576
K, mm	108	238	238
L, mm	96	112	160
M, mm	79	101	146
N, mm	295	430	440
Ø O, mm	12	14	20
P, mm	237	290	390
Q, mm	13	18	20
R, mm	21	25	32

**Fall arrest blocks for the transportation of persons, see page 277.**

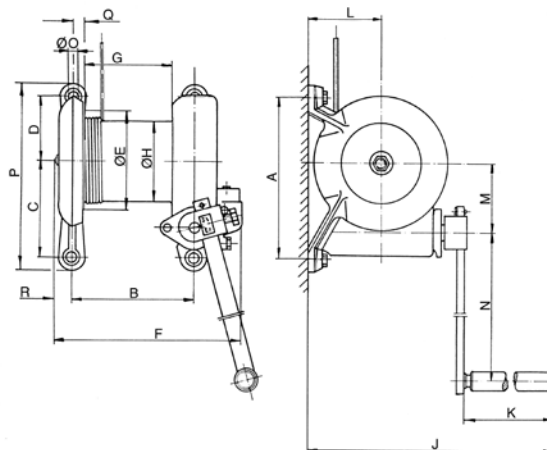

## Wall-mounted winch with worm gear drive model SW-W-SGO

Capacity 250 - 5000 kg

Wall-mounted winch with worm gear drive and load pressure brake for efficient lifting of heavy loads.

### Features

- Housing and rope drums made out of robust steel plate.
- Worm gear drive with additional load pressure brake for safe holding of the load.
- Roller bearings ensure smooth running of the rope and increased lifetime of the winch.
- Second speed for fast lifting of smaller loads, resulting in lowest possible handle effort and rapid winding of the rope (for capacities of 2000 kg and above).
- Large drum capacity with two rope outlets.
- Variable crank with adjustable crank handle for capacities up to 1500 kg.
- Easy and quick mounting.



Model SW-W-SGO  
Capacity 1500 kg

### Options

- Corrosion resistant version
- Drum with separation web for operation with several ropes.
- Grooved rope drum for improved guidance of the rope.

### Technical data model SW-W-SGO

Model	Art.-No.	Capacity	Capacity	Rope diameter*	Useable rope length 1 <sup>st</sup> layer m	Useable rope length top layer m	Lift per crank rotation mm	Required crank effort daN	Weight without rope kg
		1 <sup>st</sup> layer kg	top layer kg						
SGO 250	040251003	250	100	5	2.3	44	29	6	13
SGO 500	040252026	500	238	6	3.7	54	30	11	16
SGO 1000	040253006	1000	500	9	4.5	46	21	10.6	26
SGO 1500	040253000	1500	850	10	4.5	38	18	16	28
SGO 2000	030254002	2000	1100	13	4	37	8/16**	9/18**	60
SGO 3000	030255009	3000	2000	16	5	34.5	7/14**	12/24**	78
SGO 5000	030256013	5000	3300	20	4.5	33.8	8/16**	25.2/50.4**	105

\*recommended rope: DIN 3060 FE-znk 1770 sZ-spa      \*\*1<sup>st</sup>/2<sup>nd</sup> speed

### Dimensions model SW-W-SGO

Model	SGO 250	SGO 500	SGO 1000	SGO 1500	SGO 2000	SGO 3000	SGO 5000
Art.-No.	040251003	040252026	040253006	040253000	030254002	030255009	030256013
A, mm	238	269	302	302	410	436	436
B, mm	145	160	195	250	310	365	425
C, mm	100	115	141	178	196	251	316
D, mm	192	223	254	254	360	386	386
G, mm	106	107	110	111	137	137	137
H, mm	102	131	160	160	176	204	200
J Ø, mm	48	70	102	102	133	165	219
K Ø, mm	14	14	17	17	25	25	25
L Ø, mm	160	190	240	240	312	376	437
M, mm	191	221	266	278	383	443	495
N, mm	15	15	15	15	45	47	60
O, mm	354	384	429	441	-	-	-
P, mm	280	325	350	350	380	380	380
R, mm	171	192	264	306	420	527	604
S, mm	130	130	130	130	220	220	220

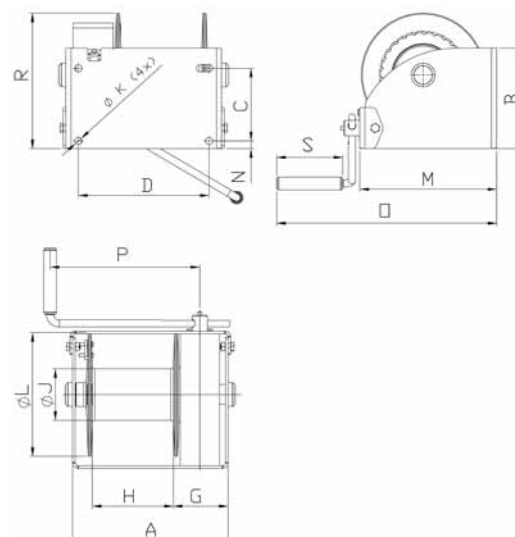



Model SW-K GAMMA  
Capacity 800 kg

**Pfaff winches are not designed for passenger elevation applications and must not be used for this purpose.**



Model SW-K GAMMA  
Capacity 500 kg

## Console-mounted aluminium rope winch model SW-K GAMMA

Capacity 200 - 800 kg

Due to its rugged design, the aluminium rope winch is suitable for operation outdoors.

### Features

- Compact aluminium housing and enclosed sprocket wheel drive. From a capacity of 500 kg with speed increasing ratio for small loads and quicker winding and unwinding of the unloaded rope.
- Spur gear drive for optimal efficiency and comfortable handling.
- Enclosed gear for the protection of parts inside, also for arduous applications.
- Low-friction shaft sliding bearings for improved rope lead-off and a longer service life of the winch.
- Wide rope drum for a large rope capacity with two rope attachment points.
- Easy and quick mounting.
- With integrated safety spring brake system and removable crank. The winches can be operated from either side.

### Options

- Increased corrosion protection owing to additional paint finish.
- Drum separation web for double rope operation

## Technical data model SW-K GAMMA

Model	Art.-No.	Capacity 1 <sup>st</sup> layer	Capacity top layer	Rope diameter*	Useable rope length 1 <sup>st</sup> layer	Useable rope length top layer	Lift per crank rotation	Required crank effort	Ratio	Weight without rope
		kg	kg	mm	m	m	mm	daN		kg
GAMMA 200	040270004	200	110	4	3.6	40	195	19	-	6
GAMMA 500	040270001	500	200	6	4.2	50	60/400**	12	6.57:1	14
GAMMA 800	040270006	800	350	7	5.3	78	36/280**	18	7.57:1	16

\*recommended rope: DIN 3060 FE-znk 1770 sZ-spa

\*\*load/speed increasing ratio

## Dimensions model SW-K GAMMA

Model	GAMMA 200	GAMMA 500	GAMMA 800
Art.-No.	040270004	040270001	040270006
A, mm	120	120	200
B, mm	160	220	326
C, mm	192	330	336
D, mm	152	100	180
E, mm	165	267	327
F, mm	135	125	250
G Ø, mm	9.5	11	14
H Ø, mm	50	60	70
L, mm	320	250	320
M, mm	207	165	207

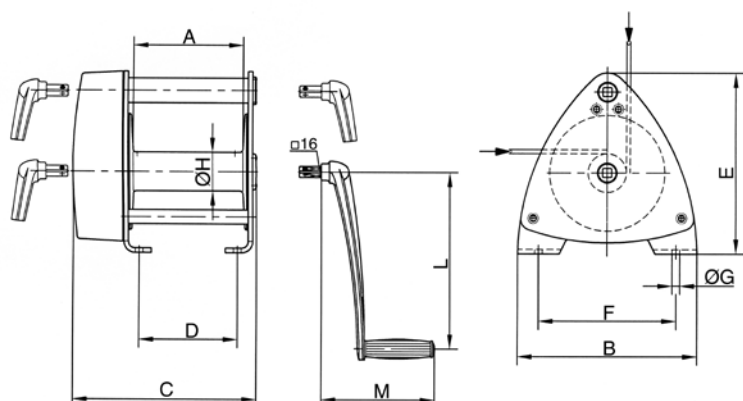

## Compact aluminium rope winch with free-wheeling device model SW-KAL

Capacity 750 - 1120 kg

Console-mounted rope winches are used for superstructures on vehicles and trailers and when lifting and lowering loads.

### Features

- Self-locking worm gear, free-wheeling device for ease of operation.
- Enclosed gear for the protection of internal parts, also for arduous applications.
- Low-friction shaft bearings for a longer service life of the winch.
- Easy and quick mounting.

### Options

- Increased corrosion protection owing to additional paint finish.
- Mirror-image design.
- Design without free-wheeling device.
- Removable crank.



### Technical data model SW-KAL

Model	Art.-No.	Capacity 1 <sup>st</sup> layer kg	Capacity top layer kg	Drum diameter mm	Rope diameter* mm	Useable rope length 1 <sup>st</sup> layer m	Useable rope length max. m	Lift per crank rotation 1 <sup>st</sup> layer mm	Lift per crank rotation top layer mm	Required crank effort daN	Weight without rope kg
KAL 750	030207004	750	600	100	6	1.3	10	15	17	20	7
KAL 1120	030208000	1120	600	63	7	0.5	10	11	16	22	7

\*recommended rope: DIN 3060 SE-znk 1770 sZ-spa

### Dimensions model SW-KAL

Model	KAL 750	KAL 1120
Art.-No.	030207004	030208000
A, mm	165	165
B, mm	168	168
C, mm	170	170
Ø D, mm	100	63
E, mm	180	180
F, mm	135	135
G, mm	60	60
H, mm	56	50
J, mm	160	160
Ø K, mm	13	13
L, mm	85	85

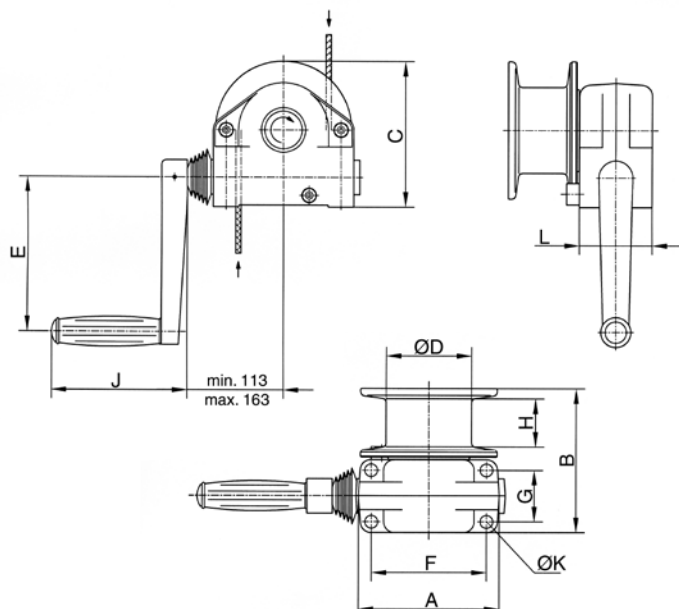



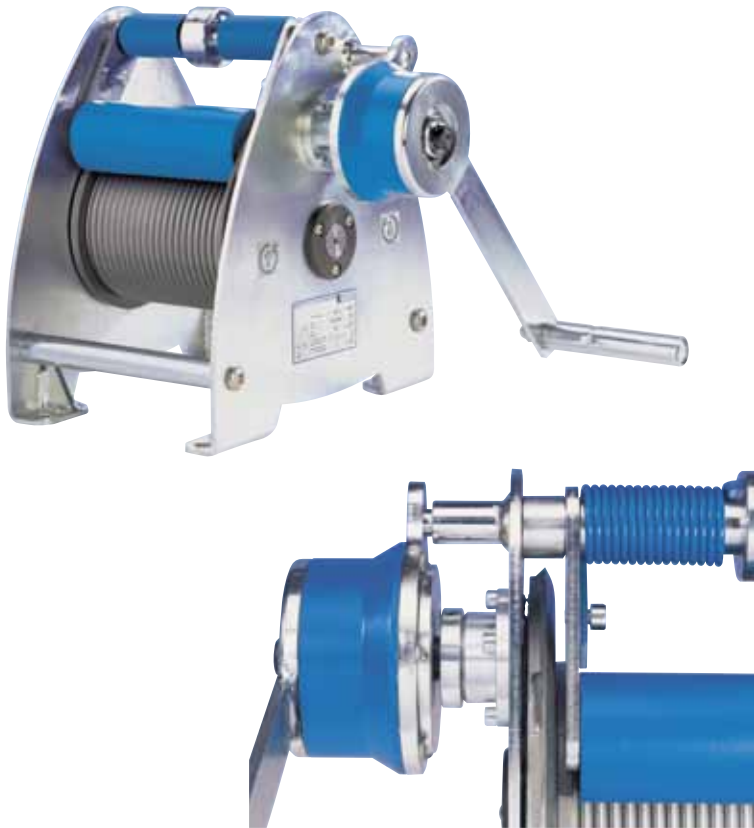

## Console-mounted rope winch model SW-K LAMBDA (BGVC1)

Capacity 300 kg

The compact rope winch for applications on stages, in studios, theatres, etc.

### Features

- State-of-the-art design with galvanized side sections for easy handling.
- Grooved drum for single-layer winding of the steel rope. An 18:1 ratio between drum and rope diameter increases the service life of the rope substantially.
- With spring-loaded rope pressure roller to prevent the unloaded rope from jumping off the drum.
- Gear rated for twice the nominal load.
- Spur gear drive for optimal efficiency and comfortable handling.
- The fitted safety crank with two spring brakes acting independently of each other for safe holding of the load in any position.
- Complies with the latest accident prevention regulations BGV C1 (DIN 56925) as well as the prototype and safety test (GS-test – tested safety) of the German committee for lifting equipment.

### Options

- Drum extension for a larger rope capacity.
- Special grooves (several ropes)

**Pfaff winches are not designed for passenger elevation applications and must not be used for this purpose.**

## Technical data model Lambda (BGVC1)

Art.-No.	Capacity kg	Rope diameter* mm	Useable rope length 1 <sup>st</sup> layer mm	Lift per crank rotation mm	Required crank effort daN	Ratio	Weight without rope kg
030272015	300	6	10	50	18	8.83:1	30
030272017	300	6	15	50	18	8.83:1	36

\*recommended steel rope: 6 DIN 3069 SE-znk 1960 sZ-spa, (breaking load of the rope min. 30,4 kN)

## Dimensions model Lambda (BGVC1)

Art.-No.	030272015	030272017
A, mm	379	469
B, mm	310	310
C, mm	340	340
Ø D, mm	139.4	139.4
E, mm	180	270
F, mm	280	280
G, mm	175	265
Ø H, mm	13	13
J, mm	250	250
K, mm	130	130

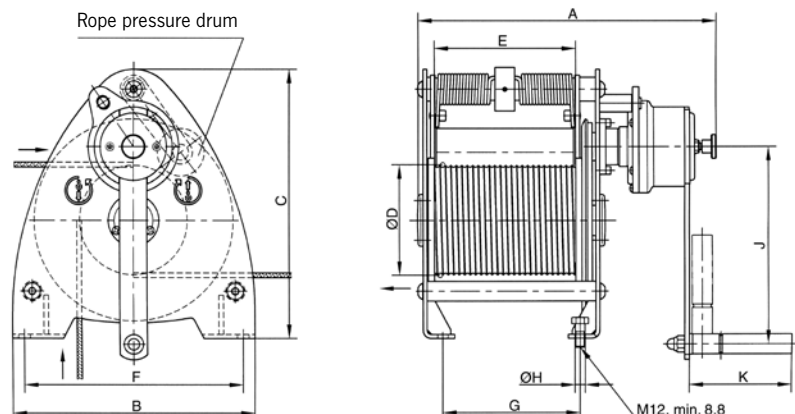

## Sheave block for rope guidance, equipped with ball bearings model DSRB S

### Technical data model DSRB

Model	Art.-No.	Classification FEM/ISO	Pulling force in kg at deflection 90°	Pulling force in kg at deflection 180°	Rope diameter mm
DSRB S 90/4	033447103	2m/M5	700	500	3-4
DSRB S 90/6	033447413	1Dm/M1	700	500	5-6
DSRB S 145/7	033447106	1Am/M4	1100	800	7
DSRB S 185/8	033447107	2m/M5	2300	1630	8
DSRB S 270/12	033447111	2m/M5	2500	1800	9-12
DSRB S 400/16	033447113	3m/M6	5000	3800	13-16
DSRB S 490/20	033447115	3m/M6	8000	6000	20

All sheaves are available as an individual component on request.

### Dimensions model DSRB

Model	DSRB S 90/4	DSRB S 90/6	DSRB S 145/7	DSRB S 185/8	DSRB S 270/12	DSRB S 400/16	DSRB S 490/20
Art.-No.	033447103	033447413	033447106	033447107	033447111	033447113	033447115
B, mm	85	85	125	138	191	302	313
C, mm	90	90	160	195	290	430	580
Ø D, mm	90	90	145	185	270	400	490
Ø D1, mm	20	25	25	30	40	50	65
Ø Dm, mm	80	78	126	160	246	368	450
E, mm	62	62	88	106	138	212	220
H, mm	134	134	224	273	407	612	694
K, mm	65	65	110	135	202	310	340
L, mm	120	120	200	245	360	530	650
Ø M/M1, mm	9/9	9/9	11.5/13	13.5/15	18/20	26/30	34/40
S, mm	4	6	6	8	10	15	16

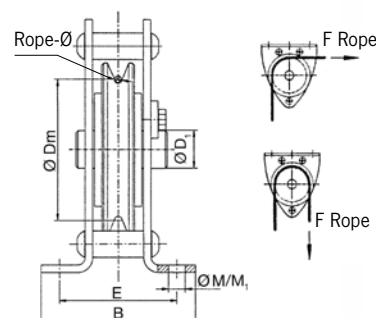
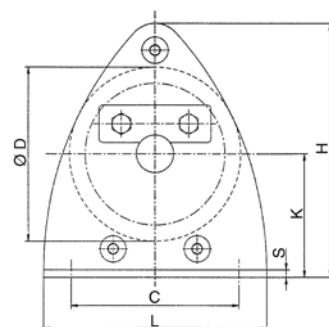

## Standard ropes for Pfaff-silberblau manual winches

According to DIN 3060

### Article-numbers

Rope diameter	Breaking load of rope min. kN	Useable rope length 5 m	Useable rope length 10 m	Useable rope length 15 m	Useable rope length 20 m	Capacity clevis end kg
4 mm - DIN 3060	10.1	033600405	033600410	033600415	033600420	500
5 mm - DIN 3060	15.8	033600505	033600510	033600515	033600520	1000
6 mm - DIN 3060	22.8	033600605	033600610	033600615	033600620	1000
7 mm - DIN 3060	31.0	033600705	033600710	033600715	033600720	1000
7 mm - DIN 3069*	43.9	-	-	033601715	-	1600

\*Rope with increased breaking load for model LB 1200 kg

**Additional accessories available on request.**

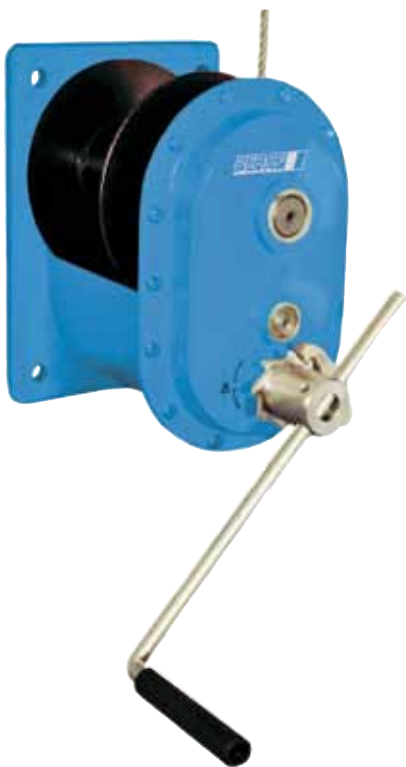

### Manual winch with worm gear drive model MWS

Capacity 125 - 2000 kg

For the operation where no electricity is available or in a dirty environment.

Recommended rope diameter according to  
DIN 3060 FE-znk 1770 sZ-spa.

The rope is not part of the delivery package.

#### Features

- Enclosed gear drive for protection of internal parts, even under tough working conditions.
- Spur gears on roller bearings, rope drum on plain bearings.
- Compact design.
- Easy and quick mounting onto walls, poles etc.
- They have a self-locking, anti-kickback and adjustable crank handle for fast lifting of smaller loads, resulting in lowest possible handle effort and rapid winding of the rope.
- Automatic load pressure brake for safe holding and extremely sensitive lowering of the load. Unintentional brake release is prevented even with swinging loads.
- They are suitable for operation in ambient temperatures of  $-20^{\circ}\text{C}$  up to  $+40^{\circ}\text{C}$ .

#### Option

- Corrosion resistant version

**!** Pfaff winches are not designed for passenger elevation applications and must not be used for this purpose.

## Technical data model MWS

Model	EAN-No. 4025092*	Capacity 1 <sup>st</sup> layer kg	Capacity top layer kg	Crank effort 1 <sup>st</sup> layer daN	Lift per crank rotation 1 <sup>st</sup> layer mm	Lift per crank rotation top layer mm	Ratio	Weight without rope kg	Rope diameter* mm	Breaking load of rope min. kN	Useable rope length 1 <sup>st</sup> layer m	Useable rope length max. m	Number of layers max.
MWS 125	*080064	125	55	11	120	390	1:1	7	3	5.7	2.6	52	16
MWS 300	*080071	300	120	7	21	57	1:7.4	10	5	15.9	1.3	26	9
MWS 500	*080088	500	323	13	30	52	1:7.4	11	6	22.9	1.4	12	5
MWS 1000	*080095	1000	684	15	21	33	1:17	28	9	51	3.4	27	5
MWS 2000	*080101	2000	1712	24	16	19	1:25.7	32	13	106	2.3	7	2

\*recommended rope: DIN 3060 FE-znk 1770 sZ-spa

## Dimensions model MWS

Model	MWS 125	MWS 300	MWS 500	MWS 1000	MWS 2000
A, mm	70	200	200	230	230
B, mm	305	300	300	340	340
C, mm	270	268	268	280	280
D, mm	168	168	168	180	180
G, mm	40	15	15	27	27
H, mm	85	60	60	126	126
Ø J, mm	32	50	70	102	121
K, mm	14	12	12	17	17
Ø L, mm	141	140	140	212	212
M, mm	198	198	198	266	288
N, mm	153	108	108	118	118
O, mm	325	263	263	425	425
P, mm	300	250	250	250	250
S, mm	128	128	128	128	128

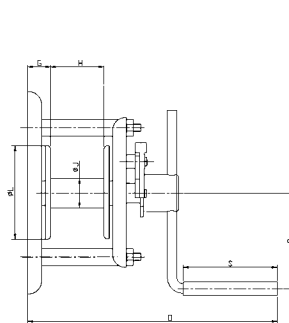

Model MWS, capacity 125 kg

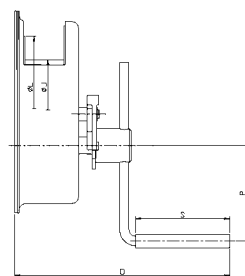
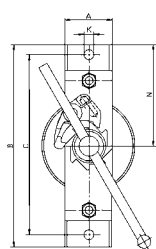

Model MWS, capacity 300 - 500 kg

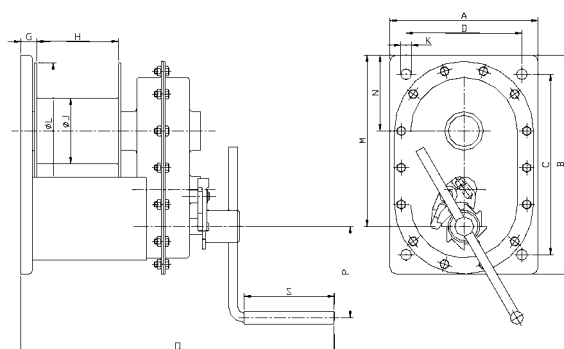
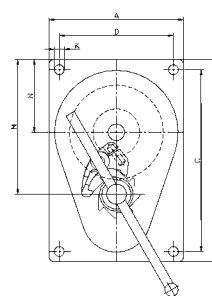

Model MWS, capacity 1000 - 2000 kg

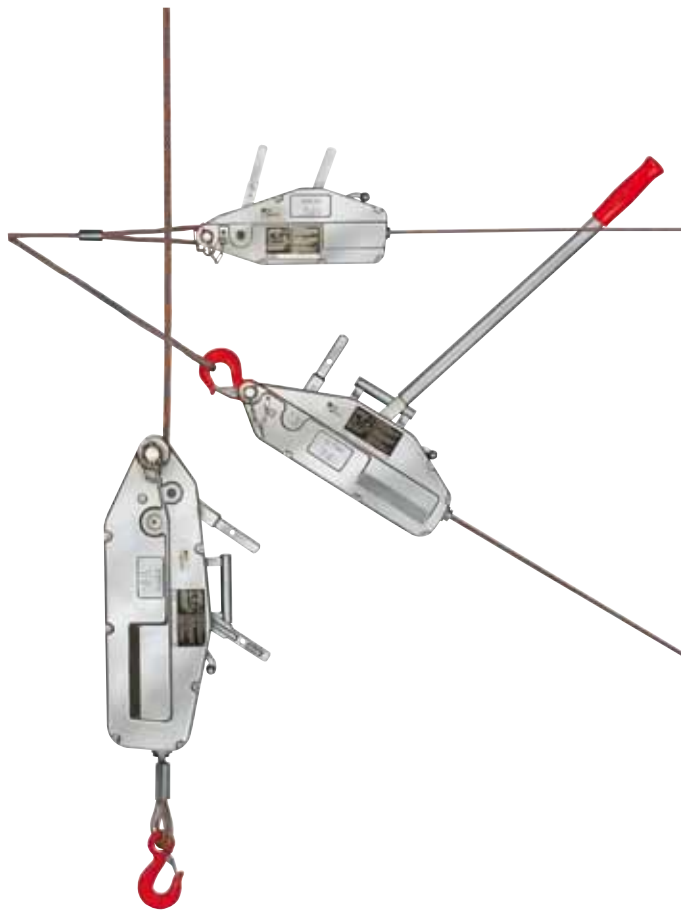

## Cable puller model Yaletrac

Pulling force 800 - 3200 daN

It has a light weight, compact, high tensile aluminium alloy housing with a large flat bottom surface for increased stability in horizontal as well as vertical working position.

### Features

- Forward and reversing levers in tandem provide slim design and assure power transfer along the centre line.
- Overload protection is by a shearing pin in the forward lever. Spare shear pins are conveniently located in the carrying handle or operating lever. A broken pin can be replaced without removing the load.
- A lever disengages the rope clamp system allowing easy, smooth installation of the rope.
- Yaletrac uses a special flexible rope. It has six strands with a steel core and is identified by an orange strand. The rope is tapered at one end for easy threading and fitted with an eye sling hook with safety latch on the other end.
- The parallel arrangement of the clamping system protects the rope by distributing the clamping forces evenly. A long rope advance per each lever stroke increases the working speed.
- The large opening in the top of the unit allows easy cleaning: simply flush the unit with water, apply motor oil for lubrication and the Yaletrac is again ready for use.

### Options

- Eye sling hook with safety latch
- Longer ropes
- Drum reel
- Storage box

**!** Yale hoists and trolleys are not designed for passenger elevation applications and must not be used for this purpose.

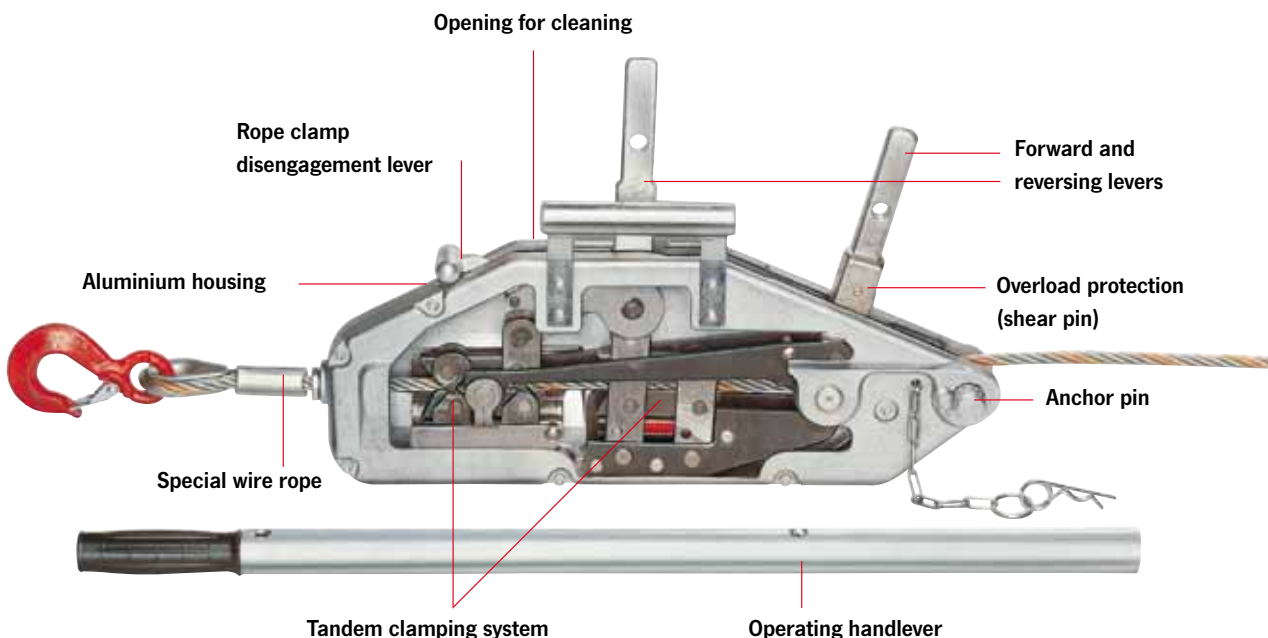

## Technical data model Yaletrac

Model	EAN-No. 4025092*	Capacity WLL kg	Rope advance per double stroke in mm	Lever pull at WLL daN	Lever length mm	Rope diameter mm	Weight without rope kg	Rope weight kg/m
Y 08	*051811	800	60	24	800	8.4	7	0.29
Y 16	*051828	1600	60	30	790/1190	11.5	14	0.53
Y 32	*078870	3200	40	50	790/1190	16	21	1

## Dimensions model Yaletrac

Model	Y 08	Y 16	Y 32
L, mm	430	545	680
H, mm	168	190	230
H1, mm	240	270	330
B, mm	60	72	91
B1, mm	-	97	110

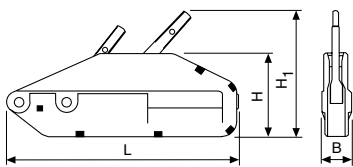

Model Y 08

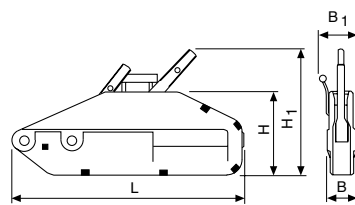

Model Y 16

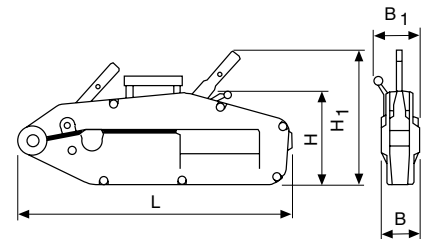

Model Y 32



Option:  
Yaletrac storage box made from steel plate,  
approx. 74x26x45 cm



Option:  
Eye sling hook with safety latch

**Complementary products available like cable grips (see page 97), pulley blocks (see page 96) and textile slings (see pages 236-238).**





## Cable puller model LP

### Capacity 500 kg

A practical aid for pulling, lifting, tensioning and lowering in many applications in- and outdoors.

A compact, handy tool – ideal for service and assembly, for workshops and recreation.

### Features

- The stamped steel housing is lightweight and resistant.
- The complete set comprises of a cable puller with anchor bolt and eye sling hook, telescopic operating lever, 10 metres of wire rope, carrying handle and a webbing sling of 1 metre length which can be used as a rigging point.

### Technical data model LP

Model	EAN-No. 4025092*	Capacity WLL kg	Rope advance per double stroke mm	Lever pull at WLL daN	Lever length mm	Rope diameter mm	Weight without rope and lever kg
LP 500	*051804	500	35	15	600	8.3	4

**!** Yale hoists and trolleys are not designed for passenger elevation applications and must not be used for this purpose.

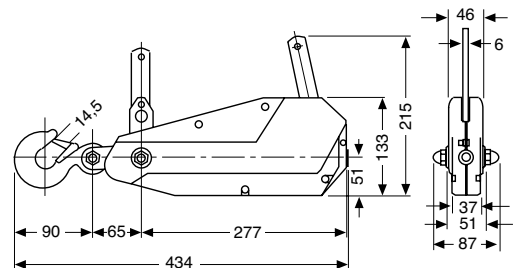

## Cable puller model LM

Pulling force 500 - 1800 daN

The use of aluminium alloy castings provide a light-weight, corrosion resistant unit for pulling and tensioning applications. The double interlocking pawl system ensures safe function, all load bearing shafts are mounted on prelubricated bearings to reduce wear.

### Features

- All springs and shafts are manufactured from stainless steel. The lifting medium is a non-twisting, galvanized, special steel wire rope.
- The hooks are fitted with safety latches and are free to rotate 360°.
- The cable puller LM can be used in single or double legged configuration. In double legged configuration the pulling force is doubled and the lifting height is halved.



**!** Yale hoists and trolleys are not designed for passenger elevation applications and must not be used for this purpose.

### Technical data model LM

Model	EAN-No. 4025092*	1 legged design pulling force daN	1 legged design hook path m	1 legged design headroom mm	2 legged design pulling force daN	2 legged design hook path m	2 legged design headroom mm	Weight kg	Lever length mm	Hook opening mm	Rope diameter mm
115 DV-B	*077293	500	4.6	550	1000	2.3	700	4.5	420	22	4.8
202 WN-VB	*077309	500	6.0	525	1000	3.0	690	5.2	520	22	4.8
434 WN-VB	*077316	500	9.0	550	1000	4.5	710	5.8	530	22	4.8
S 434 WN-VB	*077491	700	6.0	565	1400	3.0	725	6.0	530	22	5.6
S 404 WN-VB	*077323	900	5.2	575	1800	2.6	720	5.9	635	22	6.4

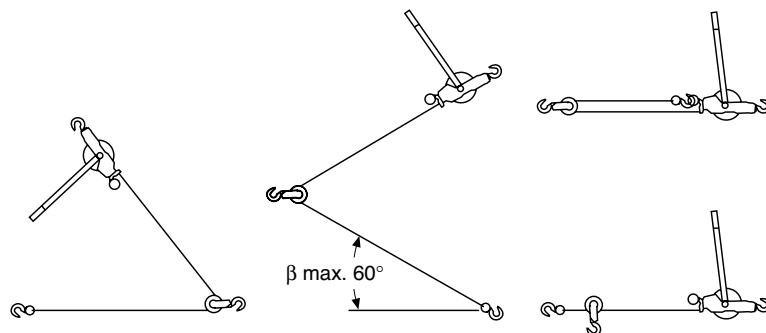

Rigging configurations - Attention! reduced capacity

**!** The units may only be used for pulling and tensioning. Lifting and lowering of loads is not permitted.

## Pulley blocks, hinged, with single steel sheave

Capacity 1000 - 6400 kg

One side of the Yale pulley blocks is hinged and can be opened for easy and quick positioning of the wire rope on the sheave. It can also provide a quick and versatile rigging point or redirect a wire rope.

### Features

- Swinging the hook in the direction of pull securely locks the pulley block.
- The high quality cast steel sheaves have machined grooves and are fitted with Permaglide® bushes.
- When choosing and classifying pulley blocks, take the "Principles for Rope Drives" DIN 15020 into consideration.



**!** Yale hoists and trolleys are not designed for passenger elevation applications and must not be used for this purpose.

### Technical data pulley blocks

Model	EAN-No. 4025092*	Capacity kg	Rope diameter mm	Weight kg
Pulley blocks 1000	*455817	1000	7	3.3
Pulley blocks 2000	*455794	2000	13	8.9
Pulley blocks 3200	*455800	3200	15	15.5
Pulley blocks 6400	*455824	6400	18	26.5

### Dimensions pulley blocks

Model	Pulley blocks 1000	Pulley blocks 2000	Pulley blocks 3200	Pulley blocks 6400
B, mm	118	199	230	270
B1, mm	76	92	108	116
B2, mm	17	24	28	35
C, mm	23	27	31	42
Ø D1, mm	85	150	180	210
Ø D2, mm	105	190	220	260
L, mm	305	425	496	655
L1, mm	200	263	295	375
L2, mm	23	30	40	47
R, mm	4	7	9	10

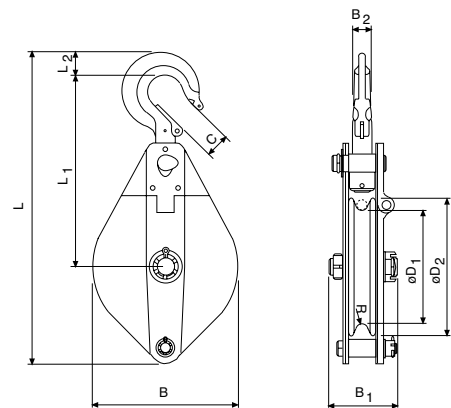

## Cable grip model LMG

### Pulling force 2000 - 5000 daN

The LITTLE MULE<sup>®</sup> cable grip is a device for gripping, pulling and tensioning uncoated wire ropes, cables and metal rods in all forms up to a tensile strength of 1770 N/mm<sup>2</sup> but is dependant on the diameter and surface condition.

The parallel jaws provide a firm, non-slip grip without causing damage to the wire rope. A special spring-loaded guide prevents the grip from dropping off the wire rope and allows instant release without jamming.

The model LMG II-X is supplied with grooved jaws and is suitable for wire ropes with a tensile strength of up to 1960 N/mm<sup>2</sup>, but is dependant on the rope diameter and surface condition.



### Technical data model LMG

Model	EAN-No. 4025092*	Pulling force daN	For rope diameter mm	Eye opening mm	Weight kg
LMG I	*052214	2000	5 - 15	31x44	1.6
LMG II	*052221	3000	8 - 20	31x44	2.9
LMG II-X	*052245	3000	8 - 20	31x44	2.9
LMG III	*052238	5000	18 - 32	66x93	9.5

**!** Yale hoists and trolleys are not designed for passenger elevation applications and must not be used for this purpose.

## Steel rope for manual and electric winches

All Pfaff-silberblau electric winches are supplied without load bearing mechanisms as standard. To ensure safe operation an optimum rope design, optimum length and associated fastening elements (hooks, shackles) are selected.

We recommend to choose wire ropes on the basis of design, type of construction and strength to suit the intended use and frequency of use. The features of the different types of rope design are as follows:

### Breaking load

→ Load bearing capacity, strength of the rope

### Bending fatigue + flexibility

→ Service life

### External wear

→ Stability of the outer strands

### Torsion characteristics

→ Lifting of guided or unguided loads

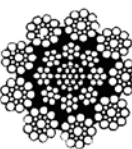
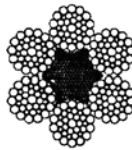
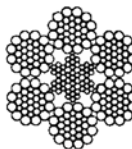
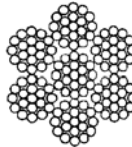
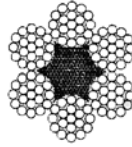

## Handling

Our product range includes winches for lifting, pulling and moving of loads. In combination to our winches the following rope types apply:

### Standard design

**DIN 3060 - 6 x 19 + FE 1770 N/mm<sup>2</sup>**

**Manual winch rope with fiber inlay 3 - 12 mm Ø**

Galvanized or stainless steel in mat. 1.4401

Nominal strength 1570 N/mm<sup>2</sup> (low breaking load)

- not non-twisting
- crosslay type of construction
- low-tension
- lifting rope for infrequent actuation
- rugged and widely resistant

### Warrington-Seale

**6 x 36 WS + SES (FE) 1770 N/mm<sup>2</sup>**

**Manual and electric winch rope in parallel type of construction, 10 - 28 mm Ø**

Galvanized, with fiber or steel inlays as options

- highly flexible
- high breaking load
- average number of reversed bending stresses

### Non-rotating special rope

**SE-znk - 1960 N/mm<sup>2</sup>**

**Standard rope for electric winches**

**Non-rotating spiral strand rope, 3 - 13 mm Ø**

Galvanized

- balanced characteristics
- lifting rope for unguided single rope suspension elements
- lifting rope for large lifting heights with multiple rope suspension elements
- not to be used with a swivel
- high strength
- high bending fatigue characteristics

### Heavy duty winch rope

**Electric winch rope with plastic-coated steel core in double-parallel type of construction, 6 - 30 mm Ø**

Bright and greased, not non-twisting

- special rope for frequent bending stress reversals and long use.
- to be used only with matching rope sheaves and drums.
- optimized break loads due to higher fill factor.

**The use of plastic-coated steel wire ropes with lifting equipment is not permitted.**

**To meet individual requirements we can provide assistance for the selection of length, diameter and type of the rope, as well as a fastening equipment (thimbles, hooks, rope clips, etc.).**

## Rope fasteners/rope connections

The safe functioning of the rope drive depends to a large extent on the rope fastenings on the winch and on the load. Rope connections and ropes themselves have to be checked at regular intervals by competent persons. The following rope connections are permissible for use with lifting equipment:

### Non-releasable rope connections

#### Aluminium press-on connection with thimbles

in combination with safety eye hooks or screw shackles provide a simple and safe means of suspending loads.

#### Splice connections DIN 3089 (uncoated)

in combination with thimbles, hooks, etc.

In the most unfavourable situation, splice connections can lead to a reduction in the breaking load of the rope line of up to 40%.

**Pressed and splice connections may only be produced by specialist firms or rope manufacturers.**

### Releasable rope connections:

#### Rope clips

- The end which is not under load must never be fastened to the load-bearing line.
- The length of the unloaded rope end should be at least 20 times the diameter of the rope and not less than 150 mm.
- Clips may no longer be used once the rope has worn by more than 10%.
- Wire rope clamps may not be used for rope connections for lifting equipment, with the exception of fastening equipment which is manufactured for non-recurring, special purposes!

## Handling of ropes – Unwinding

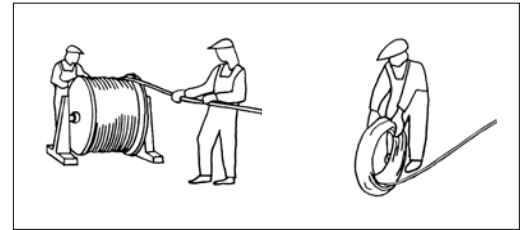

RIGHT

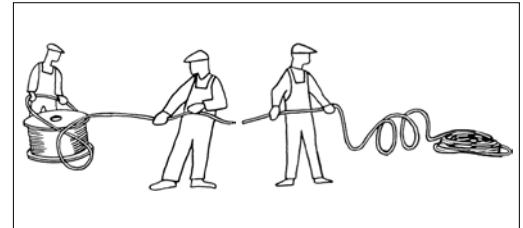

WRONG

## Care of ropes

"Running ropes" in particular will only offer optimum service lives if they are well lubricated. The use of steel ropes without grease will cause them to wear quickly and the load bearing mechanism will have to be replaced early.

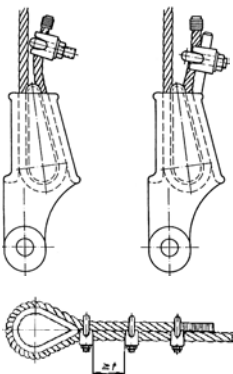
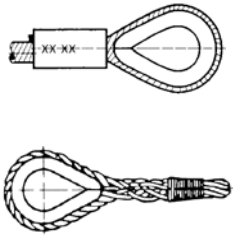

## Notes on the installation of winches:

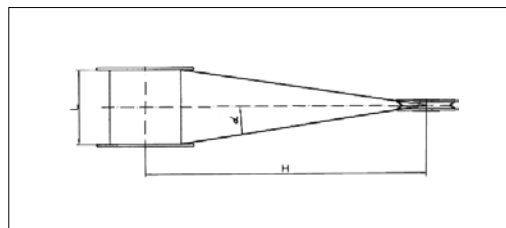

The distance between rope drum and sheave must be selected in a way that the maximum deflection angle for the type of rope used is not exceeded:

**Standard rope – Deflection angle < 3°**  
(Minimum distance = Drum width x 10)

**Special rope – Deflection angle < 1,5°**  
(Minimum distance = Drum width x 20)

- To prevent the wire rope from becoming slack when unloaded it should always have an additional rope weight when used with lifting equipment.
- Guided loads must be monitored with a slack rope cut-out.
- To prevent the rope from becoming damaged, steel wire ropes must never be guided:
  - over edges
  - over deflection radii which are too small or
  - over rope sheaves with grooves which are too small.
- High dynamic forces can lead to sudden breaks or crashes of the load. It is therefore imperative that loads are never brought to a dead stop ("on block") and that loads are never allowed to drop into the rope.





## Electric & pneumatic winches

Pfaff-silberblau and Yale winches are versatile tools made to lift, lower, pull or position loads.

All winches are characterized by high-quality components and drive motors, irrespective of the design as standard or customized version. All products are differentiated by long lifetimes and a reliable operational safety.

Pfaff-silberblau and Yale winches are available as electric or pneumatic winches.

Capacities between 250 kg up to 7.500 kg make them a versatile tool for a great number of applications: general industry, aviation and maritime industries, construction, theatres and studios, distributors, retailing and trade, furniture and department stores as well as passenger elevation (YaleMtrac).

A modular system with multiple options ensures maximum flexibility in the application.

The electric winch model BETA PROLINE is available also for stages and studios, according to BGV C1.

**Selected models can be provided in an explosion protected version.**



**All our winches are designed according to national and international standards.**

## Electric construction winch model EBW 200

Capacity 200 kg

For easy and quick lifting and lowering of loads on construction sites.

### Features

- Extending slewing frame and clips for tube racks up to max. 45 mm, quickly ready for use.
- Operating cable (length: 1 m) and push-button pendant control with emergency stop.
- Standard operating voltage: Euro-voltage 230V, 1-phase, 50 Hz



### Technical data model EBW 200

Model	Art.-No.	Capacity kg	Lifting height m	Lifting speed m/min.	Weight without rope kg
EBW 200	031100030	200	25	19.2	48.5

**!** Pfaff winches are not designed for passenger elevation applications and must not be used for this purpose.

## Electric winch model RPE

Capacity 250 - 1000 kg

Winches series RPE and RPA are designed explicitly for performance, efficiency and safety and offer many advantages and options. RPE's and RPA's extremely compact, practical cube design and universal rope lead-offs allow individual applications in almost any position and make them powerful aids for lifting and pulling loads.

The winches are designed to DIN 15020, classification 1 Bm, safety regulation BGV D8 (winch, lift and pull equipment) and, of course, the EC machinery directives.

Every winch is factory tested with overload.

The units are supplied with a test certificate showing the unit's serial-no. and an operating instructions manual which contains a manufacturer's declaration.

### Features

- Compact dimensions due to internal brake motor.
- Voltage 400V/230V, 3-phase, 50 Hz, protected to IP 54, insulation class F.
- Adjustable slip clutch to protect the winch from overloading standard for model RPE 10-6.
- Spur gear transmission with helical first gear ensures smooth motion. Lubricated by grease and can, therefore, be used in any position.
- Spring pressure disc brake incorporated in the motor holds the load secure even in the event of a power failure.
- Plain rope drum standard.
- The rope is secured to the drum in a recess so that the rope can be wound onto the drum in several layers without damage.
- Direct control or 42V low voltage control (incl. push-button with emergency-stop and 2 m control cable).



Rope attachment



Spring pressure disc brake



Brake motor

**When selecting the length of the rope please bear in mind that a minimum of 2.5 windings have to remain on the drum (approx. 1 m rope).**

## Options

- Different drum designs, e.g. extended to accommodate longer rope, machined grooves for exact reeling, with separation web and 2<sup>nd</sup> rope outlet for working with two ropes.
- Geared limit switches to limit rope motion in both directions (in combination with 42V low voltage control).
- Single-phase A.C. motor 230V, 50 Hz, 42V low voltage control.
- Slack rope switch to automatically stop the winch when rope tension eases e.g. when the load touches down (only in combination with low voltage control).
- Frequency converter for stepless speed control.
- Adjustable slip clutch to protect the winch from overloading for models RPE 2-13, RPE 5-6 and RPE 5-12.
- Special design according to BGV C1 for theater stage applications available.
- Radio remote control
- Other operating voltages
- Stainless brake



**!** Special design for wind energy as well as customised constructions on request.  
**●** Also available as zinc-plated version on request.



Single-phase A.C. motor



Geared limit switches



Gearbox with slip clutch



Different drum designs



## Technical data model RPE

Model	EAN-No. 4025092*	Capacity 1 <sup>st</sup> layer kg	Capacity top layer kg	Lifting speed 1 <sup>st</sup> layer m/min	Lifting speed top layer m/min	Rope diameter mm	Motor kW	ED at 120 c/h %	Useable rope length 1 <sup>st</sup> layer m	Useable rope length top layer m	Weight without rope kg
RPE 2-13	*071796	330	250	10.2	13.2	4	0.55	40	11.2	54.5	31.8
RPE 5-6	*071857	735	510	4.6	6.6	6	0.55	40	7.0	38.8	32.8
RPE 5-12	*071918	770	535	8.7	12.6	6	1.1	40	11.0	55.4	41.0
RPE 9-6	*071956	1320	990	5.1	6.5	8	1.1	40	10.2	37.4	76.0
RPE 10-6*	*072014	1320	1035	5.1	6.5	8	1.1	40	10.2	37.4	76.9

\*With slip clutch

## Plain drum (longer useable rope length)

Model	Capacity top layer kg	Drum size	Useable rope length max. m
RPE 2-13 L	250	2	80
RPE 5-6 L	500	2	58
RPE 9-6/10-6 L	990/1000	2	56
RPE 2-13 XL	250	3	200
RPE 5-6 XL	500	3	140
RPE 5-12 XL	500	3	140
RPE 9-6/10-6 XL	990/1000	3	100

## Grooved drum (recommended for single layer operation)

Model	Capacity top layer kg	Drum size	Useable rope length 1 <sup>st</sup> layer m	Useable rope length max. m
RPE 2-13 R	250	1	8.8	43
RPE 5-6 R	500	1	6.2	33
RPE 9-6/10-6 R	990/1000	1	8.2	30
RPE 2-13 LR	250	2	13.3	64
RPE 5-6 LR	500	2	9.5	49
RPE 5-12 LR	500	2	9.5	49
RPE 9-6/10-6 LR	990/1000	2	12.9	47
RPE 2-13 XLR	250	3	35.3	165
RPE 5-6 XLR	500	3	25.7	128
RPE 5-12 XLR	500	3	25.7	128
RPE 9-6/10-6 XLR	990/1000	3	25.2	89

Dimensions model RPE (400V direct control, standard drum)

Model	RPE 2-13	RPE 5-6	RPE 5-12	RPE 9-6	RPE 10-6
A, mm	405	405	405	525	525
B, mm	375	375	375	485	485
C, mm	18	18	18	25	25
DTR, mm	76	76	76	108	108
Dmax, mm	104	118	118	148	148
DA, mm	150	150	150	180	180
E, mm	338	338	428	450	450
F, mm	210	210	300	270	270
G, mm	260	260	350	345	345
H, mm	290	290	380	380	380
I, mm	11	11	11	13	13
K, mm	250	250	250	340	340
L, mm	125	125	125	170	170
M, mm	6	6	6	10	10
N, mm	33	33	33	47.5	47.5
O, mm	194	194	284	250	250
P, mm	19	19	19	24	24
Q, mm	13	13	13	19	19
R, mm	125	125	125	170	170
S, mm	4	6	6	8	8
$\alpha 1, ^\circ$	130	130	130	145	145
$\alpha 2, ^\circ$	110	110	110	125	125
$\alpha 3, ^\circ$	40	40	40	50	50
$\beta 1, ^\circ$	150	150	150	155	155
$\beta 2, ^\circ$	90	90	90	100	100
$\beta 3, ^\circ$	80	80	80	83	83

\*Dimensions for models with optional features are available on request!

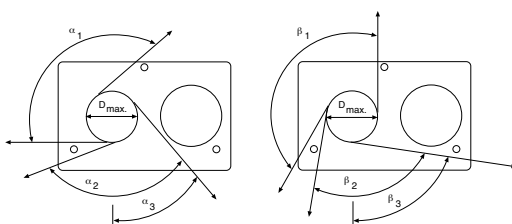
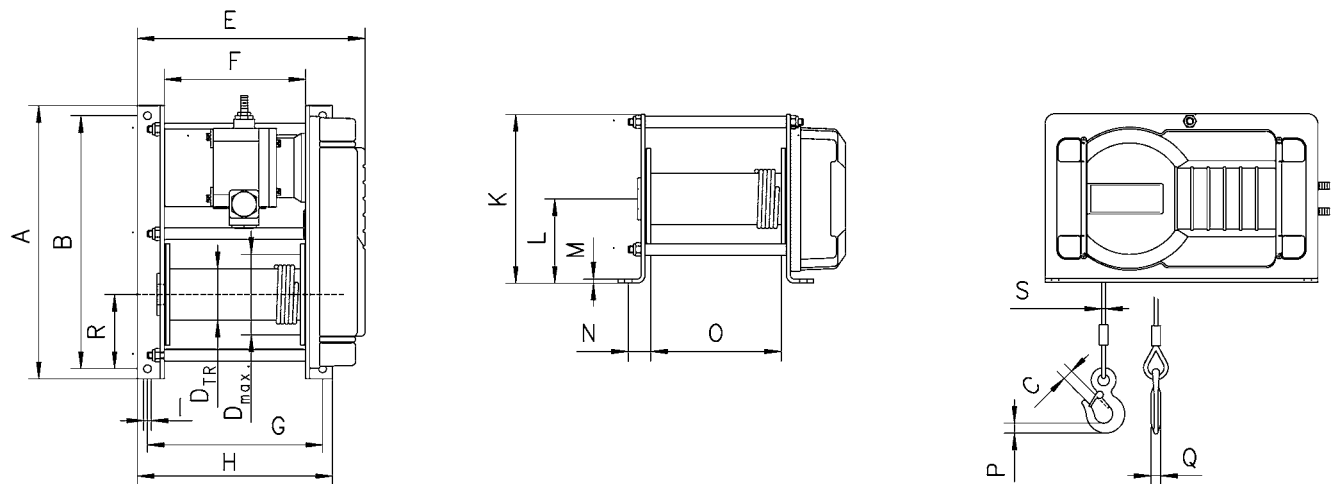

Rope lead-offs for electric winch model RPE

**!** Yale winches are not designed for passenger elevation applications and must not be used for this purpose.





## Pneumatic winch model RPA

Pulling force 250 - 500 daN

The conception is in accordance with the design of the model RPE.

With 100% duty rating and an unlimited number of starts the model RPA is suitable for heavy duty applications. It is insusceptible to contamination, humidity and aggressive mediums from the outside.

### Features

- Robust rotating piston motor with high starting torque, designed for operating pressures 4 to 6 bar.
- Spring pressure disc brake incorporated in the motor holds the load secure even in the event of an air failure.
- Sensitive control by means of direct acting valves in the control switch.

### Options

- Different drum designs, e.g. extended to accommodate longer rope, machined grooves for exact reeling, with separation web and 2nd rope outlet for working with two ropes.
- Control including 2.5 m hose and air coupler.
- Maintenance unit for main air supply pipe (pressure regulator, manometer, lubricator and support).

**To ensure faultless operation the compressed air supply must be filtered and oiled.**



Rope attachment



Different drum designs

**Available in corrosion proof version on request!**

## Technical data model RPA

Model	EAN-No. 4025092*	Capacity 1 <sup>st</sup> layer kg	Capacity* top layer kg	Lifting speed with rated load* m/min	Lifting speed without load* m/min	Lowering speed with rated load* m/min	Rope diameter mm	Motor kW	Useable rope length top layer m	Weight without rope kg
RPA 2-13	*072397	330	250	12.5	20	22	4	0.55	54.5	36.7
RPA 5-6	*072458	735	510	6.2	10	11	6	0.55	38.8	36.7

\*Values in the top layer for 6 bar, air consumption 0,75 m<sup>3</sup>/min

## Dimensions model RPA

Model	RPA 2-13	RPA 5-6
A, mm	405	405
B, mm	375	375
C, mm	18	18
DTR, mm	76	76
Dmax, mm	104	118
DA, mm	150	150
E, mm	336	336
F, mm	210	210
G, mm	260	260
H, mm	290	290
I, mm	11	11
K, mm	250	250
L, mm	125	125
M, mm	6	6
N, mm	33	33
O, mm	194	194
P, mm	19	19
Q, mm	13	13
R, mm	125	125
S, mm	4	6
α 1, °	130	130
α 2, °	90	90
α 3, °	20	20
β 1, °	150	150
β 2, °	70	70
β 3, °	60	60

When selecting the length of the rope please bear in mind that a minimum of 2.5 windings have to remain on the drum (approx. 1 m rope).

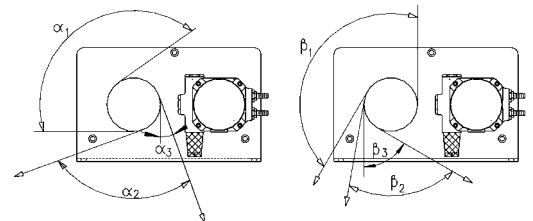

Rope lead-offs for pneumatic rope winch RPA

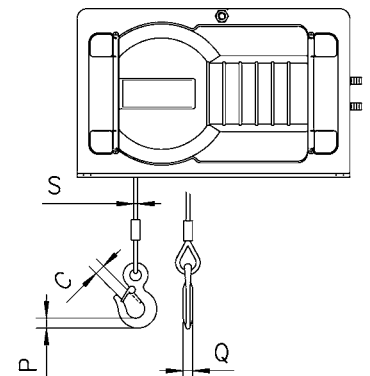
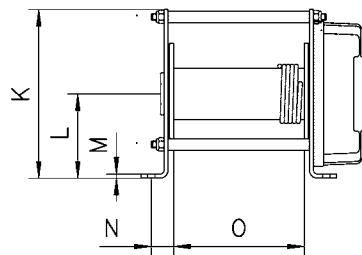
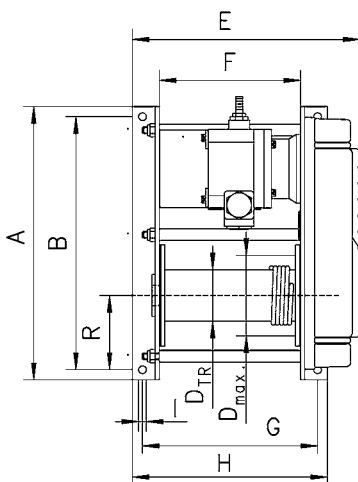



**In compliance with accident prevention regulations BGV C1, also available for application on stages and in studios.**

## Options

- Various drum designs e.g. extended for a larger rope capacity, special rope drums for operation with several ropes.
- Rope pressure rollers to prevent the unloaded rope from jumping off the drum.
- Adjustable gear limit switch for limiting the rope path in both directions.
- Slack rope switch for automatically stopping the winch when the rope tension eases or when the load is set down.
- Frequency inverter for infinitely variable speed control.
- External operation via cable/radio
- Other operating voltages
- Other motor protection
- Absolute or incremental encoder
- Pole-changing motors
- Special preservation

## Electric winch model SW-E BETA PROLINE

Capacity 250 - 7000 kg

Electric winches of the BETA PROLINE range are used for lifting, towing and positioning of loads under demanding conditions. All models are based on a modular system; a high degree of flexibility ensures tailor-made solutions owing to a large number of options.

The application of high-quality components and gear motors ensure safety and a long service life.

### Features

- The electrically released spring pressure disc brake safely holds the load also in the event of a power failure.
- Powerful three-phase AC drives for multi-range voltage 380 - 420 V, 50 Hz or 440 - 460 V, 60 Hz. Motor type of enclosure IP 55, duty factor 40 % ED.
- Electronic overload protection from 1000 kg lifting load as standard.
- The maintenance-free, oil lubricated gearbox has quiet running characteristics due to milled and ground gears with helical teeth.
- All parts with high-quality two component paint (RAL 5015, coat thickness approx. 120 µm), rope drum zinc-plated in addition.
- Standard rope drum of grooved design, with large rope capacity.
- Variable rope lead-in due to two rope attachment points (left and right).
- Increased operating safety due to 42 V contactor control.
- Complies with accident prevention regulations BGV D 8.

**For determining the required rope length, please take into account that at least 2 to 3 windings must remain on the drum!**

## Technical data model SW-E BETA PROLINE

Art.-No.	Size	Capacity	Capacity	Lifting	Lifting	Rope diameter*	Recom- mended rope tensile strength N/mm <sup>2</sup>	Motor	Classifi- cation	Useable	Useable	Weight without rope
		1 <sup>st</sup> layer	top layer	speed 1 <sup>st</sup> layer	speed top layer					rope length 1 <sup>st</sup> layer	rope length top layer	
		kg	kg	m/min	m/min	mm		kW	FEM/ISO	m	m	kg
031148012	1	250	212	9.5	11.2	5	1770	0.42	2m/M5	16.2	77.8	62
031148018	1	250	212	13.8	16.4	5	1770	0.60	2m/M5	16.2	77.8	63
031148024	1	250	212	19.0	23.0	5	1770	0.93	2m/M5	16.2	77.8	64
031148007	1	320	272	6.0	7.1	5	1960	0.32	2m/M5	16.2	77.8	63
031148013	1	320	272	9.6	11.3	5	1960	0.54	2m/M5	16.2	77.8	63
031148019	1	320	272	13.8	16.4	5	1960	0.77	2m/M5	16.2	77.8	64
031148025	1	320	272	21.3	25.8	5	1960	1.19	2m/M5	16.2	77.8	67
031148077	1	500	343	8.5	12.6	6	1960	0.75	1Am/M4	8.4	58.5	64
031148208	2	500	414	10.3	12.5	8	1770	0.91	2m/M5	17.1	85.5	104
031148209	2	630	522	10.3	12.5	8	1770	1.14	2m/M5	17.1	85.5	104
031148219	2	630	522	20.3	24.8	8	1770	2.25	2m/M5	17.1	85.5	111
031148205	2	800	663	4.8	5.7	8	1960	0.67	2m/M5	17.1	85.5	101
031148210	2	800	663	10.3	12.5	8	1960	1.45	2m/M5	17.1	85.5	104
031148220	2	800	663	20.5	25.0	8	1960	2.87	2m/M5	17.1	85.5	114
031148259	2	980	689	7.5	10.7	9	1960	1.28	1Am/M4	11	77.4	104
031148403	3	1250	1066	5.2	6.2	12	1770	1.15	2m/M5	16.3	61.3	165
031148406	3	1250	1066	11.5	13.6	12	1770	2.41	2m/M5	16.3	61.3	174
031148441	3	1600	1100	8.5	12.5	12	1960	2.28	1Am/M4	12.1	87.7	174
031148444	3	1600	1100	11.5	17.0	12	1960	3.50	1Am/M4	12.1	87.7	173
031148504	3.5	2000	1667	7.6	9.6	14	1770	2.66	2m/M5	13.8	53.9	221
031148507	3.5	2000	1667	10.6	12.9	14	1770	3.89	2m/M5	13.8	53.9	234
031148510	3.5	2000	1667	16.3	20.3	14	1770	5.72	2m/M5	13.8	53.9	246
031148505	3.5	2500	2083	7.6	8.9	14	1770	3.35	2m/M5	13.8	53.9	224
031148502	3.5	2500	2083	5.5	6.5	14	1770	2.40	2m/M5	13.8	53.9	221
031148511	3.5	2500	2083	16.3	20.3	14	1770	7.15	2m/M5	13.8	53.9	246
031148530	3.5	3200	2354	4.5	6.1	14	2160	2.52	1Am/M4	11.4	64.5	221
031148536	3.5	3200	2354	8.7	12.0	14	2160	5.10	1Am/M4	11.4	64.5	234
031148620	4	3200	2647	22.1	27.2	18	1770	12.19	2m/M5	15.6	62	503
031148644	4	4000	2664	5.7	8.7	18	1960	4.38	1Am/M4	12.7	98.3	435
031148652	4	4000	2664	11.2	17.2	18	1960	7.85	1Am/M4	12.7	98.3	468
031148802	5	5000	4207	3.9	4.6	20	1960	3.66	2m/M5	20.3	79.2	1047
031148804	5	5000	4207	8.1	9.7	20	1960	7.58	2m/M5	20.3	79.2	1019
031148823	5	6300	4690	3.4	4.3	20	2160	3.72	1Am/M4	16.4	93.4	1047
031148825	5	6300	4690	6.5	8.8	20	2160	7.71	1Am/M4	16.4	93.4	1019
031148840	5	7500	4810	5.3	8.3	20	2160	7.44	1Bm/M3	13.4	104.8	1019
031148842	5	7500	4810	10.4	16.4	20	2160	13.46	1Bm/M3	13.4	104.8	1098

\*recommended rope: DIN 3069 SE-znk 1960, non-rotating



**!** Pfaff winches are not designed for passenger elevation applications and must not be used for this purpose.

## Dimensions model SW-E BETA PROLINE

Art.-No.	031148012	031148018	031148024	03118007	031148013	031148019	031148025	031148077	031148208
A, mm	695	725	725	710	725	725	780	725	907
B, mm	333	343	343	333	343	343	352	343	490
C, mm	325	325	325	325	325	325	325	325	444
D Ø, mm	175	175	175	175	175	175	175	108	242
L2, mm	264	264	264	264	264	264	264	264	338

Art.-No.	031148209	031148219	031148205	031148210	031148220	031148259	031148403	031148406	031148441
A, mm	907	940	852	907	940	907	1014	1065	1065
B, mm	490	490	490	490	490	490	614	614	614
C, mm	444	444	444	444	444	444	547	547	547
D Ø, mm	242	242	242	242	242	175	295	295	218
L2, mm	338	338	338	338	338	338	406	406	406

Art.-No.	031148444	031148504	031148507	031148510	031148505	031148502	031148511	031148530	031148536
A, mm	1037	1091	1147	1258	1091	1091	1258	1091	1147
B, mm	614	684	684	684	684	684	684	684	684
C, mm	547	547	547	547	547	547	547	547	547
D Ø, mm	218	295	295	295	295	295	295	242	242
L2, mm	406	406	406	406	406	406	406	406	406

Art.-No.	031148620	031148644	031148652	031148802	031148804	031148823	031148825	031148840	031148842
A, mm	1408	1265	1374	1549	1549	1549	1549	1549	1617
B, mm	826	826	826	1046	1046	1046	1046	1046	1046
C, mm	687	687	687	844	844	844	844	844	844
D Ø, mm	364	295	295	451	451	364	364	295	295
L2, mm	480	480	480	568	568	568	568	568	568

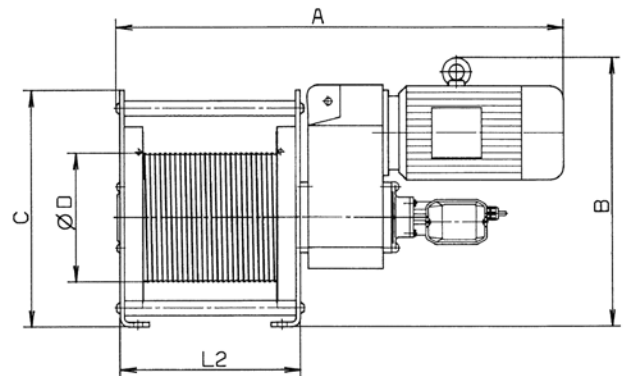

**Pfaff winches are not designed for passenger elevation applications and must not be used for this purpose.**

Sheave block  
for rope guidance,  
equipped with ball bearings  
model DSRB S

Technical data model DSRB S

Model	Art.-No.	Classification FEM/ISO	Pulling force in kg at deflection 90°	Pulling force in kg at deflection 180°	Rope diameter mm
DSRB S 90/4	033447103	2m/M5	700	500	4
DSRB S 145/5	033447104	4m/M6	1100	800	5
DSRB S 145/6	033447105	2m/M5	1100	800	6
DSRB S 185/8	033447107	2m/M5	2300	1630	8
DSRB S 185/9	033447108	1Am/M4	2300	1630	9
DSRB S 270/12	033447111	2m/M5	2500	1800	12
DSRB S 325/14	033447117	2m/M5	4500	3200	14
DSRB S 400/16	033447113	3m/M6	5000	3800	16
DSRB S 400/18	033447114	2m/M5	5000	3800	18
DSRB S 490/20	033447115	3m/M6	8000	6000	20



Dimensions model DSRB S

Model	DSRB S 90/4	DSRB S 145/5	DSRB S 145/6	DSRB S 185/8	DSRB S 185/9	DSRB S 270/12	DSRB S 325/14	DSRB S 400/16	DSRB S 400/18	DSRB S 490/20
Art.-No.	033447103	033447104	033447105	033447107	033447108	033447111	033447117	033447113	033447114	033447115
B, mm	85	125	125	138	138	191	260	302	302	313
C, mm	90	160	160	195	195	290	350	430	430	580
Ø D, mm	90	145	145	185	185	270	325	400	400	490
Ø D1, mm	20	25	25	30	30	40	50	50	50	65
Ø Dm, mm	80	125	125	160	162	246	297	368	364	450
E, mm	62	88	88	106	106	138	180	212	212	220
H, mm	134	224	224	273	273	407	490	612	612	694
K, mm	65	110	110	135	135	202	242	310	310	340
L, mm	120	200	200	245	245	360	440	530	530	650
Ø M/M1, mm	9/9	11,5/13	11,5/13	13,5/15	13,5/15	18/20	22/25	26/30	26/30	34/40
S, mm	4	6	6	8	8	10	12	15	15	16

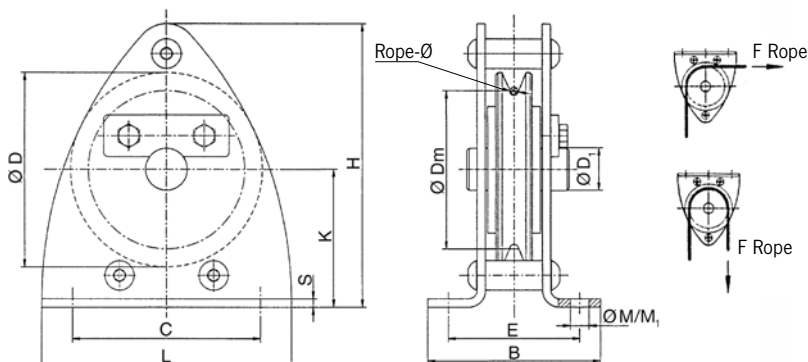





For determining the required rope length, please take into account that at least 2 to 3 windings must remain on the drum!

Pfaff winches are not designed for passenger elevation applications and must not be used for this purpose.

## Electric winch model BETA SILVERLINE

Capacity 125 - 3200 kg

Electric winches of the BETA SILVERLINE range are used for lifting, towing and positioning of loads. The proven technology and specified equipment features make the winch the ideal product for standard applications.

### Features

- The electrically released spring pressure disc brake safely holds the load also in the event of a power failure.
- Powerful three-phase AC drives for multi-range voltage 380 - 420V, 50 Hz or 440 - 460V, 60 Hz. Motor type of enclosure IP 55, duty factor 40% ED.
- Electronic overload protection from 1000 kg lifting load as standard.
- The maintenance-free, oil lubricated gearbox has quiet running characteristics due to milled and ground gears with helical teeth.
- All parts with high-quality two component paint (RAL 5015, coat thickness approx. 120 µm), rope drum zinc-plated in addition.
- Standard rope drum of grooved design, with large rope capacity.
- Variable rope lead-in due to two rope attachment points (left and right).
- The winches feature either direct or contactor control (incl. gear limit switch).
- Complies with accident prevention regulations BGV D8.

## Technical data model BETA SILVERLINE

Art.-No. Direct control	Art.-No. Contactor control	Size	Capacity 1 <sup>st</sup> layer kg	Capacity top layer kg	Lifting speed 1 <sup>st</sup> layer m/min	Lifting speed top layer m/min	Rope diameter* mm	Motor kW	Classification FEM/ISO	Useable rope length 1 <sup>st</sup> layer m	Useable rope length top layer m	Weight without rope kg
031140004	-	Mini	125	85	4.7	7.3	4	0.25	1Bm/M3	7	46.7	22
031140000	-	Mini	250	170	2.5	3.9	4	0.25	1Bm/M3	7	46.7	25
031140001	031140006	Mini	250	170	4.7	7.3	4	0.37	1Bm/M3	7	46.7	25
031140005**	031140015**	Mini	250	170	3.7	5.7	4	0.55	1Bm/M3	7	46.7	25
031148065	031149065	Size 1	500	348	3.5	5.5	6	0.37	1Am/M4	8.4	58.5	65
041148077	031149077	Size 1	500	348	8.5	12.6	6	0.75	1Am/M4	8.4	58.5	65
031148129	-	Size 1	630	400	6.8	11.0	6	0.75	1Bm/M3	6.7	48.9	60
031148254	031149254	Size 2	980	697	3.4	4.9	9	0.75	1Am/M4	11	77.5	114
041148259	031149259	Size 2	980	697	7.5	10.8	9	1.1	1Am/M4	11	77.5	120
-	031149302	Size 2	1250	814	5.9	9.2	9	1.1	1Bm/M3	8.7	64.1	125
-	031149438	Size 3	1600	1115	3.9	5.7	12	1.1	1Am/M4	12.1	87.8	204
-	031149441	Size 3	1600	1115	8.5	12.5	12	2.2	1Am/M4	12.1	87.8	210
-	031149533	Size 3.5	3200	2354	6.0	8.3	14	3	1Am/M4	11.4	64.5	224

\*recommended rope: DIN 3069 FE-znk 1960 sZ-spa

\*\*A.C. motor drive 230V

## Dimensions model BETA SILVERLINE

Art.-No. Direct	031140004	031140000	031140001	031140005*	031148065	041148077	031148129	031148254	041148259	-	-	-	-
Art.-No. Contactor	-	-	031140006	031140015*	031149065	031149077	-	031149254	031149259	031149302	031149438	031149441	031149533
A, mm	185	185	185	185	215	215	215	270	270	270	320	320	320
B, mm	170	170	170	170	300	300	300	400	400	400	510	510	510
Ø C, mm	12	12	12	12	13,5	13,5	13,5	18	18	18	22	22	22
F, mm	379	389	389	389	710	746	731	852	912	907	1014	1073	1101
G, mm	200	200	200	200	200	340	200	200	465	200	200	570	200
H, mm	222	241	241	241	333	319	343	490	487	490	614	599	684
K, mm	422	432	432	-	-	-	-	-	-	-	-	-	-
L, mm	180	180	180	180	200	200	200	250	250	250	300	300	300
Ø M, mm	64	64	64	64	108	108	86	175	175	138	218	218	242

\*A.C. motor drive 230V

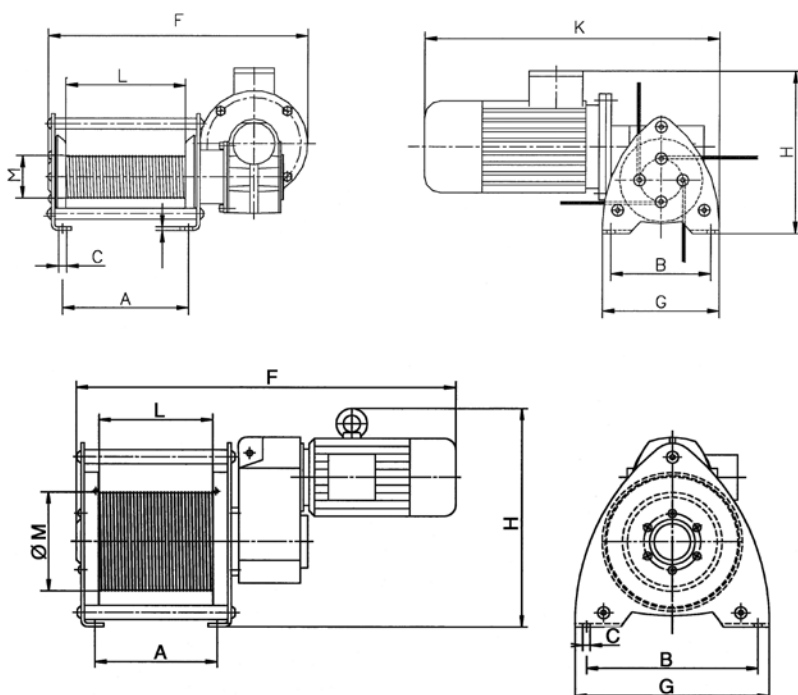

**Pfaff winches are not designed for passenger elevation applications and must not be used for this purpose.**



**Certified for passenger elevation applications in accordance with DIN EN 60204-32 by an independent inspection institute (DGUV).**

## Options

- Other operating voltages
- Radio remote control
- Double control for several winches
- Limit switch for upward and downward travel.
- Counters for operating hours and number of starts.
- Catching devices (overspeed or inclined position tripping, required for passenger elevation applications).
- Adaptor for fitting with shackle
- Ropes for endless winches and catching device.
- Overload protection (included in the scope of supply for passenger elevation winches).
- Storage reel for the unloaded rope.

## Endless winch for the transportation of goods- and personnel model YaleMtrac

With the new YaleMtrac, the rope is driven through the winch without the necessity of having to collect the rope on a reel etc. This enables unlimited lifting heights or traction lengths. Unlike a drum winch, the wire rope always enters the winch at the same place, thus eliminating undesirable hook movement across the drum and ensures rope speed and pulling force remain constant. Endless winches can be used for various applications, wherever loads have to be lifted or pulled, e.g. for the use on waggons, mobile staffolds, or wind power stations.

## Features

- The robust, precisely machined housing of die-cast aluminium ensures a low deadweight and outstanding rigidity. Standardised components feature easy access to all wearing parts.
- Drive sheave and pressure rollers made of specially hardened steel guarantee low wear of the components.
- Limit switch for lifting force as standard (only for winches for passenger elevation).
- The winch can be suspended from a central suspension point by means of a load pin. As an alternative, attachment points in the corners of the housing are available for flexible attachment of the winch with screws or pins.
- Classification: 1 Bm/M3 (1 Cm/M2 for 18 m/min) according to FEM
- All motors protected to IP55 as standard, against ingress of dust and water jets.
- Standard operating voltage: Euro-voltage 400V, 3-phase, 50 Hz alternatively 460V, 3-phase, 60 Hz.
- 24V control voltage (except material transport control, stationary application – 42V)
- Phase monitoring (except material transport control, stationary application) for an easy and safe connection to changing power supply.
- Hoist motor with thermal overload protection as standard for increased lifetime.
- Certified by an independent inspection institute (DGUV).
- Certified for passenger elevation applications in accordance with DIN EN 14492-1 by an independent inspection institute (DGUV).

## Technical data model YaleMtrac Winches for material transport

Model	EAN-No. 4025092* for stationary application**	EAN-No. 4025092* for mobile application***	Capacity  kg	Lifting speed  m/min	Nominal rope diameter  mm	Motor  kW	Weight for stationary application**  kg	Weight for mobile application***  kg
YMT 5-9-M8	*668569	*668644	500	9	8.4	1.1	54	62
YMT 5-18-M8	*668576	*668651	500	18	8.4	2.0	54	62
YMT 6-9-M8	*668583	*668668	600	9	8.4	1.1	55	63
YMT 6-18-M8	*668590	*668675	600	18	8.4	2.0	55	63
YMT 8-9-M8	*668606	*668682	800	9	8.4	1.8	55	63
YMT 8-18-M8	*668613	*668699	800	18	8.4	3.6	56	64
YMTF 8-18-M8	-	-	800	18/9	8.4	2.0/3.6	58	66
YMT 10-9-M9	*668620	*668712	980	9	9.0	1.8	55	63
YMT 10-18-M9	*668637	*668705	980	18	9.0	3.6	56	64
YMTF 10-18-M9	-	-	980	18/9	9.0	2.0/3.6	58	66

\*\*incl. control voltage 400 V, 3-phase, 50 Hz, directly attached to the winch, pendant control with emergency-stop (length of control cable 3 m)

\*\*\*incl. control cabinet with integrated CE-connector, pendant control with emergency-stop (length of control cable 3 m)

### Contactor control for material transport applications (stationary application)

- Control cabinet (260 x 124 x 95 mm)
- Protected to IP 55 (acc. to EN 60 529)
- Temperature range -20° C up to +40° C
- Increased operating safety through 42 V control voltage
- Master control relay/emergency-stop contactor as standard for a high degree of safety
- Easily accessible strip terminal
- Cable entry point by cable sleeves
- Motor connected with control cable



**Hoist motor & brake**  
Special motor with classification 1 Bm/M3 (1 Cm/M2 for 18 m/min) according to FEM/ISO 4301-1. Protected to IP 55.



**Flexible attachment points**  
Central load pin suspension or alternatively screws or pins on four corners.

### Control cabinet for material transport applications (mobile application)

- Control cabinet (300 x 400 x 150 mm)
- Protected to IP 55 (acc. to EN 60 529)
- Temperature range -20° C up to +40° C
- Increased operating safety through 24 V control voltage
- Master control relay/emergency-stop contactor as standard for a high degree of safety
- Phase-sequence relay for monitoring the direction of rotation
- Control transformer according to EN 61558-2, input and output separately fused
- Warning buzzer for signalling an overload
- Easily accessible strip terminal
- Cable entry point by screwed cable glands
- Motor connected with connector plug
- Power supply connection with phase-changing switch.
- Connection for UP emergency limit switch provided.



## Technical data model YaleMtrac Winches for passenger elevation according to EN 1808

Model	EAN-No. 4025092*	Capacity kg	Lifting speed m/min	Nominal rope diameter mm	Motor kW	Weight without rope incl. control cabinet kg
YMT 5-9-P8	*668729	500	9	8.4	1.1	72
YMT 5-18-P8	*668736	500	18	8.4	2.0	72
YMT 6-9-P8	*668743	600	9	8.4	1.1	73
YMT 6-18-P8	*668750	600	18	8.4	2.0	73
YMT 8-9-P9	*668767	800	9	9.0	1.8	73
YMT 8-18-P9	*668774	800	18	9.0	3.6	74
YMTF 8-18-P9	*911313	800	18/9	9.0	2.0/3.6	76
YMT 10-9-P10	*668781	1000	9	10.2	1.8	73
YMT 10-18-P10	*668798	1000	18	10.2	3.6	74
YMTF 10-18-P10	*911320	1000	18/9	10.2	2.0/3.6	76

Incl. control cabinet with integrated CE-connector

Option: Emergency-stop and UP/DOWN buttons on control cabinet for controlling the winch, pendant control with emergency-stop (length of control cable 3 m)

all models	
A, mm	266
B, mm	300
Ø C, mm	16.5
Ø D, mm	10.5
E, mm	40
F, mm	57
G, mm	261
H, mm	34
I, mm	375
J, mm	261
K, mm	220
Ø L, mm	180
M, mm	301
N, mm	375
O, mm	599

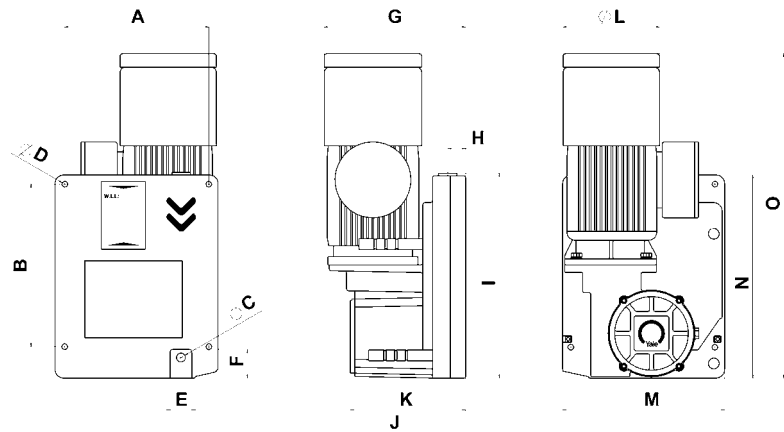

### Options

- Control cabinet for synchronous control of two winches
- Supporting feet and arms for fixing the control cabinet



### Control cabinet for passenger elevation applications

- Control cabinet (300 x 400 x 150 mm)
- Protected to IP 55 (acc. to EN 60 529)
- Temperature range -20° C up to +40° C
- Increased operating safety through 24V control voltage
- Master control relay/emergency-stop contactor as standard for a high degree of safety.
- Phase-sequence relay for monitoring the direction of rotation.
- Control transformer according to EN 61558-2, input and output separately fused.
- Warning buzzer for signalling an overload
- Easily accessible strip terminal
- Cable entry point by screwed cable glands
- Motor connected with connector plug
- Power supply connection with phase-changing switch
- Connection for UP emergency limit switch provided

## Safety for passenger elevation

In accordance with the requirements of DIN EN1808, each winch used for passenger elevation must feature a safety system on an independent safety rope. The product offering provides two different safety catching devices for two common applications.

Both types have been approved for passenger elevation and comply with standard DIN EN1808

“Safety requirements on suspended access equipment”. In addition, the catching devices have been certified by an independent inspection institute (DGUV).



**Safety hand wheel**

In an emergency (power failure), upward movement with released brake is possible by means of the hand wheel included in the supply (standard delivery scope only for winches for passenger elevation application).



**Safety lowering mechanism**

In the event of a power failure, the electro-mechanical brake can be released manually in order to ensure safe and controlled lowering of the load. Safe lowering is guaranteed by the integrated centrifugal force brake.

## Overspeed safety catching device (YOSL)

This overspeed catching device is automatically tripped when the lowering speed exceeds 30 m/min (0.5 m/s). The integrated clamping jaw mechanism of hardened steel stops the lowering movement of the system within a few centimetres.

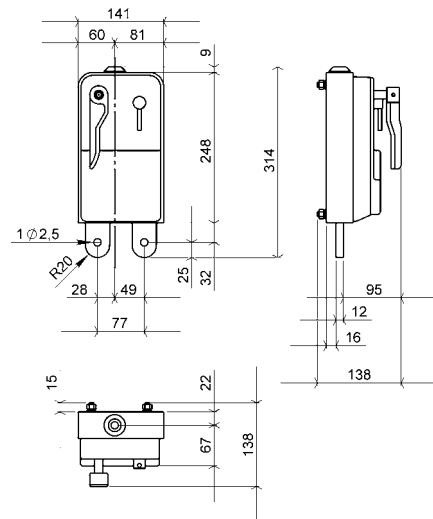

Model	EAN-No. 4025092*	Capacity kg	for rope diameter mm
YOSL6-8	*582803	500	8.4
YOSL6-8	*582803	600	8.4
YOSL8-9	*582742	800	9.0
YOSL10-10	*582766	1000	10.2

## Inclined position safety catching device (YISL)

This inclined position catching device is automatically tripped when the angle of the rope or the platform exceeds 5°.

The integrated clamping jaw mechanism holds the rope and immediately stops the movement of the system.

- Robust sheet-steel enclosure
- Clamping mechanism of hardened steel
- Attachment with two screws (M12) or load pins (12 mm)

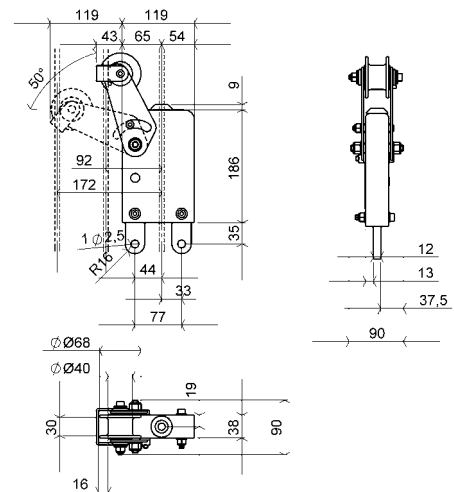

Model	EAN-No. 4025092*	Capacity kg	for rope diameter mm
YISL6-8	*582827	500	8.4
YISL6-8	*582827	600	8.4
YISL8-9	*582759	800	9.0
YISL10-10	*582797	1000	10.2





## Monorail trolley hoist with extremely low headroom model YGK-E

Extremely low headroom and compact design allow maximum hook travel. This robust and maintenance friendly hoist is suitable for many industrial applications. Due to the flexible and easily adjustable trolley, the YGK-E is easy and fast to install. Properties like the quiet and smooth running gearbox and the optimised drive characteristics of the trolley extend the life expectancy.

### Features

- Monorail trolley with extremely low headroom as standard.
- FEM/ISO classification 2m/M5. As required (with appropriate changes to lifting capacity resp. duty cycle) the model YGK-E can also be re-classified to 3m/M6.
- Control cabinet with contactors (42 V control voltage) for both trolley and hoist.
- The motor is located outside the rope drum permitting good cooling and serviceability.
- Hoist motor with thermal overload protection and limit switch, phase and motor monitoring.
- Low maintenance brake protected to IP 65
- Motor protected to IP 55 as standard (acc. to VDE 0530), insulation class F, against ingress of dust and water jets.
- Standard operating voltage: Euro-voltage 400 V, 3-phase, 50 Hz; alternatively 460 V, 3-phase, 60 Hz.
- Proven enclosed low wear rope guide made of glass reinforced polyamide ensures guiding and tensioning of the rope full 360° to avoid slack rope and subsequent damage to the rope.
- The rope can be exchanged and maintained quickly due to three screwed rope clamps and an asymmetrical wedge socket. The open design allows easy maintenance.
- Two-speeds for lifting and traction drive each. Ideal handling characteristics as two wheels are driven, one on each side of the frame. Trolley wheels are mounted on prelubricated, encapsulated ball bearings.
- Robust bottom block made of glass reinforced polyamide.
- Rotating and tiltable load hook trunnion style for easier load adjustment and positioning.



**Geared limit switches**  
The geared limit switch for the upper and lower hook position is conveniently located to allow easy access.



**Adjustment to beam flange**  
Simple adjustment of the trolley to a wide range of beam flange widths by threaded spindle



**Overload prevention device**  
prevents lifting excessive loads

### Options

- Other operating voltages
- Two-speed push-button pendant for trolley and hoist control.
- Two-speed push-button pendant for crane travelling, trolley and hoist control.
- Radio remote control
- Control cabinet with contactors for crane control.
- Other beam flange widths.
- Festooned cable system

## Technical data model YGK-E

Model	Capacity in kg/ number of chain falls	FEM/ISO	Lifting height m	Rope diameter mm	Lifting speed m/min	Hoist motor kW	Hoist motor U/min
YGK-E 1.6-6/12	1600/2	2m/M5	12	6.4	6/1.5	2.2/0.56	3000/750
YGK-E 3.2-5/6	3200/4	2m/M5	6	6.4	5/1.3	3.7/0.93	3000/750
YGK-E 3.2-5/12	3200/4	2m/M5	12	6.4	5/1.3	3.7/0.93	3000/750
YGK-E 5-5/7	5000/4	2m/M5	7.5	9	5/1.3	5.6/1.4	3000/750
YGK-E 5-5/12	5000/4	2m/M5	12	9	5/1.3	5.6/1.4	3000/750
YGK-E 10-5/7	10000/4	2m/M5	7.5	12	5/1.3	11/2.8	3000/750
YGK-E 10-5/12	10000/4	2m/M5	12	12	5/1.3	11/2.8	3000/750
YGK-E 15-4/7	15000/4	2m/M5	7.5	15	4.5/1.0	15/3.7	3000/750
YGK-E 15-4/12	15000/4	2m/M5	12	15	4.5/1.0	15/3.7	3000/750

Model	Capacity in kg/ number of chain falls	Electric trolley travel speed m/min at 50 Hz	Electric trolley motor kW at 50 H	Beam flange width			Weight kg
				A mm	B mm	C mm	
YGK-E 1.6-6/12	1600/2	12/4	0.20/0.06	117 - 216	219 - 356	-	283
YGK-E 3.2-5/6	3200/4	12/4	0.37/0.17	117 - 216	219 - 356	-	317
YGK-E 3.2-5/12	3200/4	12/4	0.37/0.17	117 - 216	219 - 356	-	363
YGK-E 5-5/7	5000/4	14/4.5	0.37/0.17	117 - 203	206 - 356	359 - 508	408
YGK-E 5-5/12	5000/4	14/4.5	0.37/0.17	117 - 203	206 - 356	359 - 508	476
YGK-E 10-5/7	10000/4	12/4	0.56/0.19	152 - 203	206 - 356	359 - 508	794
YGK-E 10-5/12	10000/4	12/4	0.56/0.19	152 - 203	206 - 356	359 - 508	862
YGK-E 15-4/7	15000/4	12/4	0.75/0.25	-	206 - 356	359 - 508	1284
YGK-E 15-4/12	15000/4	12/4	0.75/0.25	-	206 - 356	359 - 508	1415

## Control cabinet (600x400x200 mm)

### Features

- Protected to IP55 (acc. to EN 60 529)
- Temperature range -20° C up to +40° C
- Increased operating safety through 42V control voltage
- Master control relay/emergency-stop contactor as standard for increased safety
- Main switch to turn off the current for the whole system for assembly and maintenance purposes
- Motor protection switch for both trolley and hoist drives each
- Individual fuses for hoist, trolley (and crane)
- Control transformer with integrated power supply for constant current supply to the brake, input and output separately fused
- Easily accessible strip terminal
- Cable entry point by screwed cable glands.
- Additional space for terminal blocks, contactors, fuses and motor protection switch for crane control

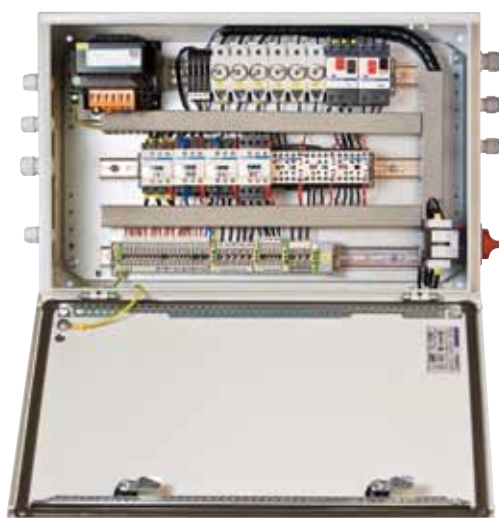

## Dimensions model YGK-E

Model	YGK-E 1.6-6/12	YGK-E 3.2-5/6	YGK-E 3.2-5/12	YGK-E 5-5/7	YGK-E 5-5/12	YGK-E 10-5/7	YGK-E 10-5/12	YGK-E 15-4/7	YGK-E 15-4/12
A min., mm	400	406	406	508	508	616	616	753	753
A max., mm	502	508	508	535	535	673	673	788	788
B, mm	270	270	270	476	476	540	540	514	514
C min., mm	219	219	219	206	206	206	206	359	359
C max., mm	356	356	356	356	356	356	356	508	508
D, mm	95	95	95	102	102	152	152	178	178
E min., mm	160	160	160	140	140	114	114	256	256
E max., mm	296	296	296	289	289	264	264	405	405
F min., mm	464	464	464	611	611	742	742	789	789
F max., mm	464	464	464	760	760	891	891	938	938
G, mm	368	375	375	454	454	575	575	611	611
H, mm	156	156	156	127	127	175	175	229	229
I, mm	165	165	165	270	270	359	359	356	356
K, mm	324	324	324	527	527	645	645	641	641
L, mm	365	375	635	524	778	532	791	597	870
M, mm	178	89	178	140	225	143	229	155	251
N, mm	327	406	406	359	359	460	460	548	548
O, mm	470	470	819	727	1060	765	1108	873	1241
P, mm	149	149	149	120	120	159	159	178	178
Q, mm	251	251	251	-	-	-	-	171	171
R, mm	76	156	156	238	238	302	302	368	368
S, mm	35	35	35	35	35	51	51	45	45
T, mm	23	34	34	43	43	55	55	69	69
U, mm	25	36	36	43	43	56	56	77	77
V, mm	27	37	37	46	46	66	66	76	76

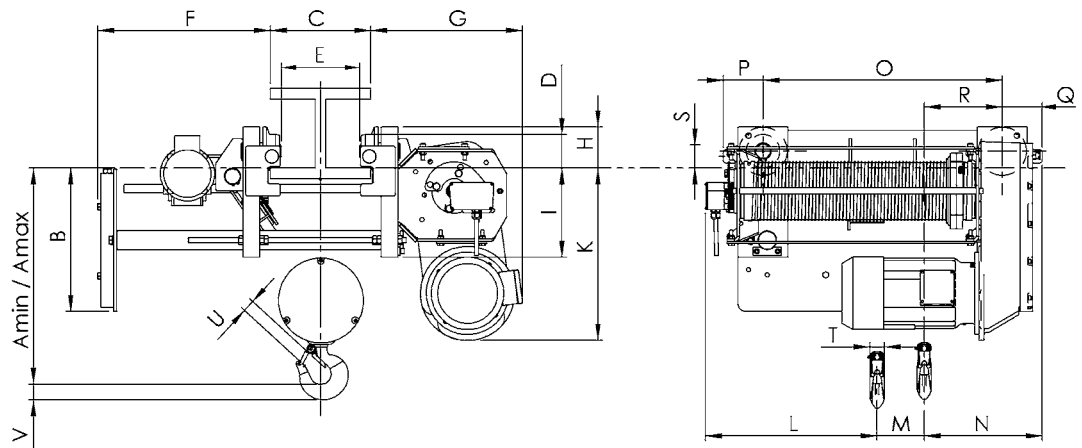

Other beam flange widths on request!



The adjacent picture shows the bottom block for a 2/1 reeving







## Ratchet jack model Yaletaurus

Capacity 10000 kg

Mechanical ratchet jacks with lifting claw are designed for operation in confined areas where space below the load is restricted, thus preventing the use of traditional lifting equipment. The Yaletaurus is the ideal unit for lifting, positioning or transportation of machines resp. heavy objects as well as for repair and assembly jobs in cramped areas and under toughest conditions.

In spite of its capacity of 10000 kg the Yaletaurus has a weight of just 30 kg and the integrated carrying handle makes it a portable, versatile tool.

With a hand force of 45 kg on the detachable hand lever, the Yaletaurus will lift, press, push or lower a load of 10000 kg in any direction. A standard crank wheel will bring the jack quickly to the required position.

### Features

- Automatic screw-and-disc type load brake.  
The axial brake pressure is generated by the load itself and is, therefore, proportional to the size of the load. The load is held secure in any position.
- Single part housing made from spheroidal cast iron with integrated lifting claw.
- The screw-and-disc type load brake originates from the Yale PUL-LIFT® (spare parts are easily available).
- Low lever pull and long life endurance due to optimum gearing and high quality materials.

### Technical data model Yaletaurus

Model	EAN-No. 4025092*	Capacity on the head kg	Capacity on the claw kg	Height mm	Lifting height mm	Hand effort at WLL daN	Weight kg
Taurus	*076043	10000	7000	505	295	45	31.1

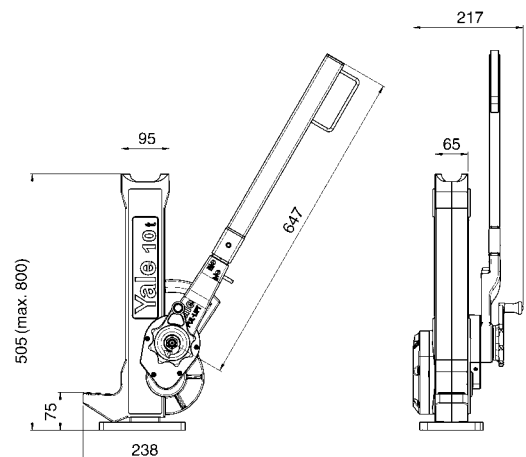

## Steel jacks acc. to DIN 7355 -with adjustable lifting claw model STW-V

Capacity 3000 - 10000 kg

## -with fixed lifting claw model STW-F

Capacity 1500 - 10000 kg

Steel jacks are traditional hoisting equipment for universal application in the forest and agricultural sector, in the industrial sector for assembly activities and many other fields of application.

### Features

- The robust steel design and a toothed rack of solid material increase the service life of the jack.
- Low wear owing to hardened gearing parts and precisely machined teething.
- The precisely machined gears with a high degree of efficiency guarantees low crank forces.
- The load is supported either on the claw or the head of the steel jack.
- Robust base plate for a high level of stability.

### Option

- Different crank versions

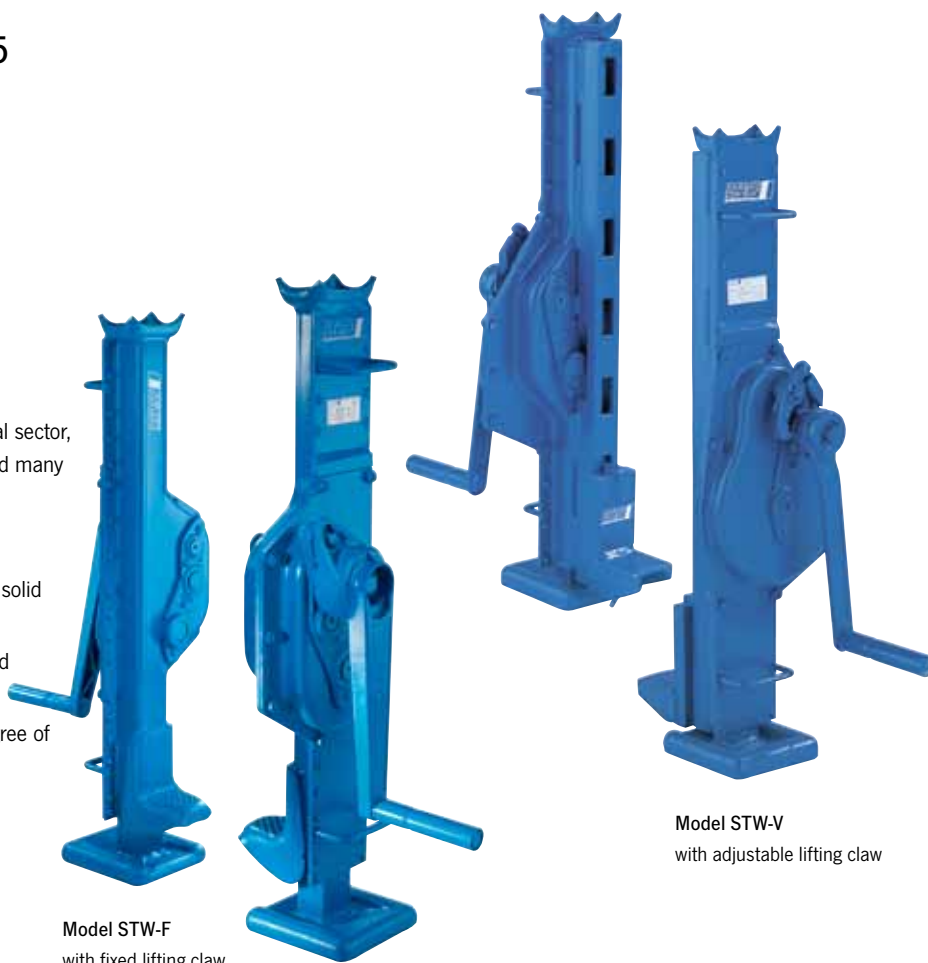

### Technical data model STW-V and model STW-F

Art.-No. Sifeku	Art.-No. Siku	Art.-No. Raku	Capacity/Type kg	Height mm	Lift mm	Weight kg
030008133	030008001	030008028	3000/V	720	350	25
030009156	030009008	030009016	5000/V	720	300	30
-	030010006	030010014	10000/V	792	300	48
030001139	030001007	030001015	1500/F	720	350	12
030002135	030002003	030002011	3000/F	720	350	21
030003131	030003069	030003018	5000/F	720	300	26
-	030004006	030004014	10000/F	792	300	42

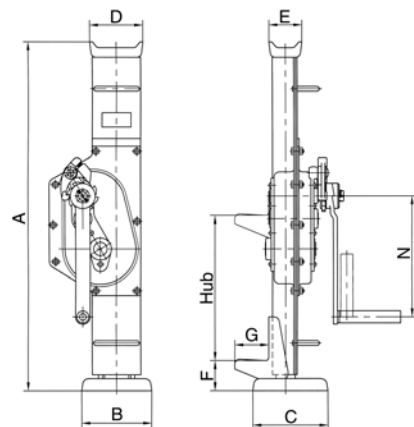

### Dimensions model STW-V and model STW-F

Art.-No. Sifeku	030008133	030009156	-	030001139	030002135	030003131	-
Art.-No. Siku	030008001	030009008	030010006	030001007	030002003	030003069	030004006
Art.-No. Raku	030008028	030009016	030010014	030001015	030002011	030003018	030004014
A, mm	720	720	792	720	720	720	792
B, mm	130	145	145	130	130	145	145
C, mm	140	155	155	140	140	155	155
D, mm	100	110	125	90	90	110	125
E, mm	50	68	80	50	50	68	80
F, mm	65	65	70	60	61	62	85
G, mm	69	62	85	60	65	70	85
H, mm	166	159	191	-	-	-	-
J, mm	263	256	297	-	-	-	-
K, mm	360	353	403	-	-	-	-
L, mm	457	450	509	-	-	-	-
M, mm	554	547	615	-	-	-	-
N, mm	250	250	300	250	250	250	300

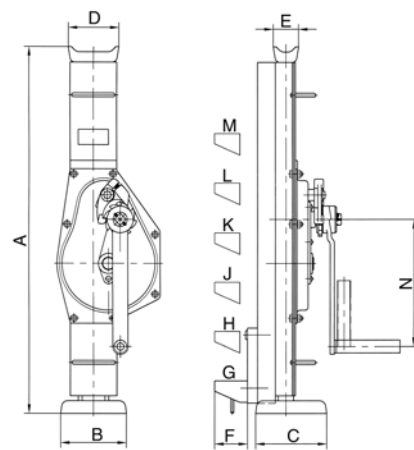





Rail jack acc. to DIN 7355 model RSJ

High stability on uneven ground is ensured by the extra large floor plate (e.g. gravel).



## Steel jack acc. to DIN 7355 model SJ

Capacity 1500 - 10000 kg

Mechanical steel jacks can basically be used to lift almost all kinds of loads in maintenance and repair, ship building, construction as well as agriculture.

### Features

- The precisely machined gear box with optimal gear ratio ensures a minimum of effort and smooth operation.
- The load can be positioned either on the head or the claw.
- By turning the operating lever the jack moves smoothly and conveniently up and down along the rack.
- The self-locking, anti-kickback operating lever reduces the risk of injuries. The handle can be tilted for use in confined spaces.
- The load is held securely in any position. Inside the load brake the axial brake pressure is generated by the load itself, thus, it is proportional to the size of the load.
- No reduction of capacity on the claw.

### Technical data model SJ and model RSJ

Model	EAN-No. 4025092*	Capacity kg	Height h5 mm	Lifting height h1 mm	Hand effort at WLL daN	Weight kg
SJ 15	*080897	1500	725	360	28	17
SJ 30	*079877	3000	735	360	28	20
SJ 50	*079884	5000	730	350	28	27
SJ 100	*080903	10000	800	410	56	43
RSJ 50	*039482	5000	740	360	28	29

### Dimensions model SJ and model RSJ

Model	SJ 15	SJ 30	SJ 50	SJ 100	RSJ 50
a, mm	76	83	108	124	108
b1, mm	164	200	190	252	190
b2, mm	38	38	52	65	52
b5, mm	140	140	170	170	170
g, mm	60	65	71	86	71
h1, mm	360	360	350	410	350
h2, mm	70	70	80	85	80
h5, mm	725	735	730	800	740
l1, mm	225	249	275	300	275
l2, mm	113	128	128	250	128
I	-	-	-	-	180
II	-	-	-	-	250
III	-	-	-	-	70
IV	-	-	-	-	45
V	-	-	-	-	10

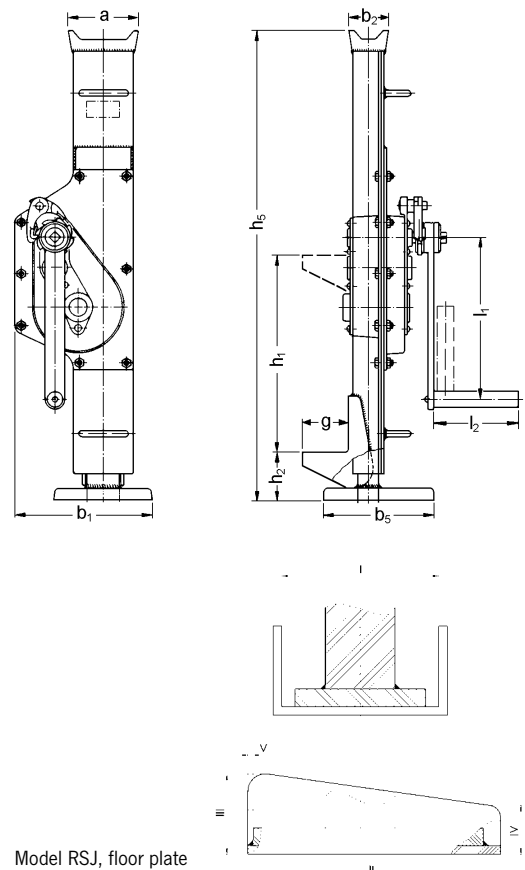

## Safety ratchet crank (Raku)

- For use in confined spaces.
- Lifting by moving the ratchet upwards and downwards.
- Lifting or lowering movement adjustable by turning a lever.
- The load is held safely at every height.
- With folding handle

### Arm length 250 mm

- Square drive 17 mm
- Max. drive torque 60 Nm (braking torque)

### Arm length 300 mm

- Square drive 17 mm
- Max. drive torque 120 Nm (braking torque)



## Safety crank (Siku)

- With one-sided braking effect
- The load is held safely at every height.
- With folding handle

### Arm length 250 mm

- Square drive 17 mm
- Max. drive torque 60 Nm (braking torque)

### Arm length 300 mm

- Square drive 17 mm
- Max. drive torque 120 Nm (braking torque)



## Spring loaded safety crank (Sifeku)

### For particularly safe application

- Without pawl
- Silent
- Recoil proof
- Maintenance-free
- Totally enclosed
- Weather and temperature resistant
- Braking effect at both ends
- The load is held safely at every height, in the pushing and pulling direction.
- Approved by the TÜV as an independent crank
- With folding handle

### Arm length 250 mm

- Square drive 17 mm
- Max. drive torque 60 Nm (braking torque)





Model ZWW  
Capacity 250 kg



Model ZWW  
Capacity 1000 kg



Model ZWW  
Capacity 1500 kg



Model ZWW  
Capacity 10000 kg

## Wall-mounted rack and pinion jacks model ZWW

Capacity 250 - 10000 kg

Wall-mounted rack and pinion jacks are used for lifting, lowering, pulling and pushing of loads.

### Features

- Robust steel design with precisely machined worm and spur gears for smooth and easy manual operation.
- Solid steel rack with additional bore hole for fastening of the load.
- Low wear owing to hardened gearing parts and precisely machined teething.
- Suitable for a lifting load of up to 5000 kg for pushing and pulling loads.
- Rigid wall mounting.

### Options

- Rack extensions
- Special fastening arrangements for shaft and rack
- Improved corrosion protection owing to zinc-plating, nickel-plating
- Spring loaded safety lock with removable crank (up to 5000 kg)

## Technical data model ZWW

Art.-No.	Gear type	Load safety	Capacity kg	Lift per crank rotation mm	Crank effort daN	Rack length mm	Lift mm	Weight kg
030052000	Worm gear	self-locking	250	11	11	740	550	9
030053007	Worm gear	self-locking	500	11	16.5	895	700	10
030054003	Worm gear	self-locking	1000	3.8	22	765	600	11
030055131	Spur gear	Sifeku	1500	14	28	1090	800	11
030056138	Spur gear	Sifeku	3000	8.6	28	975	565	19
030057134	Spur gear	Sifeku	5000	4.5	28	1170	700	28
030058009	Spur gear	Siku	10000	3.2	40	1240	700	55

## Dimensions model ZWW

Art.-No.	030052000	030053007	030054003	030055131	030056138	030057134	030058009
A, mm	35	35	35	35	45	50	60
B, mm	25	25	25	25	30	40	50
C, mm	100	100	105	215	280	330	380
D Ø, mm	16	16	21	21	21	21	30
E, mm	20	20	20	20	25	25	30
F, mm	109.5	109.5	100	135	165	140	160
G, mm	133	133	134	151	212	219	269
H, mm	195	195	160	310	395	400	480
I, mm	188	188	155	168	179	197	200
J, mm	47.5	47.5	29.5	26	31	37	39.5
K, mm	-	-	100	100	120	120	140
L, mm	52	52	130	130	160	160	180
M, mm	165	165	140	260	305	320	410
N Ø, mm	12.5	12.5	12.5	12.5	14.5	17	21
O, mm	70.5	70.5	50	110	120	105	125
P, mm	-	-	40	40	50	50	60
Q, mm	12	12	8	8	10	10	10
R, mm	165	220	165	250	250	250	300
S, mm	130	130	130	130	130	130	250
T, mm	44.5	44.5	46.8	42.4	86.25	109.1	150.4
U, mm	-	-	44	43.3	53.1	69.5	88.3
X, mm	32	32	25	20	25	45	30

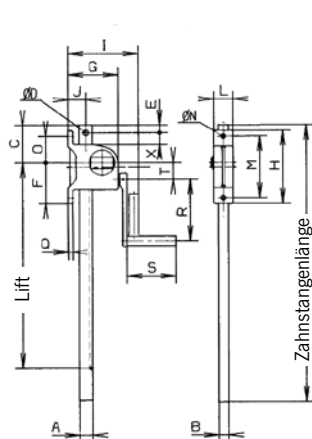

Model ZWW  
Capacity 250 - 500 kg

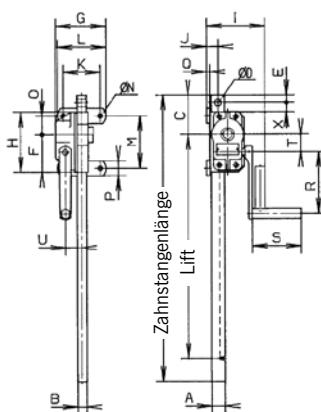

Model ZWW  
Capacity 1000 kg

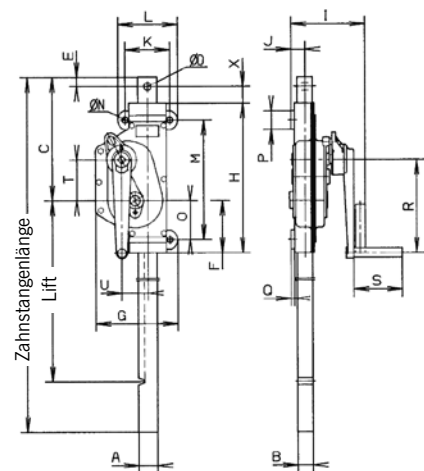

Model ZWW  
Capacity 1500 - 10000 kg



## Lifting jack model HB

Capacity 1000 kg

The stable lifting jack for supporting tube and bar material.

### Features

- The removable supporting roller facilitates sliding of heavy loads.
- The self-locking worm gear ensures safe holding of the load.
- Large base plate for a high level of stability.

### Technical data model HB

Model	Art.-No.	Capacity kg	Height mm	Lifting height mm	Weight kg
HB	030060003	1000	650	350	34

### Technical data supporting roller HB-A

Model	Art.-No.	Capacity kg	Length mm	Width mm	Height mm	Weight kg
HB-A	030060011	1000	270	65	55	5

### Dimensions model HB

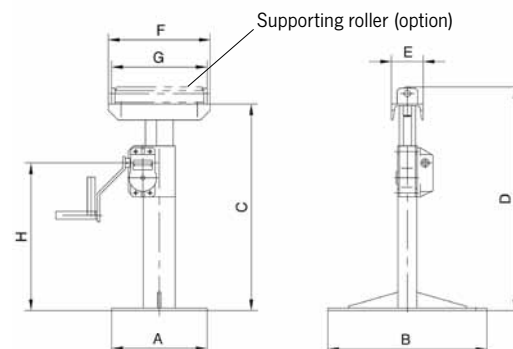

Model	
Art.-No.	030060003
A, mm	300
B, mm	500
C, mm	650
D, mm	705
E, mm	100
F, mm	320
G, mm	300
H, mm	465

## Truck body lifting jack model KHB 8, BGV D8 (VBG 8) model KHB 14, EN 1493 (VBG 14)

Capacity 3000 - 7500 kg

Truck body lifting jacks are used for supporting vehicle bridges, swap bodies and trailers; they are also used in vehicle construction and freight forwarding applications.

### Features

- High-quality, torsionally stiff steel design with large base plate for a high level of stability.
- Lockable rack of solid material and synchronized running monitoring feature (VBG 14) for synchronized lifting movements with several lifting jacks.
- Hardened gearing parts and precisely machined teeth for improved handling and low wear.
- The load can either be supported on the head or on the adjustable claw.

### Options

- Non-slip rubber plates for head and claw.
- Lifting beam with pendulating suspension arrangement (only for BGV D8).
- Design as truck body lifting platform jack according to VBG 14 accident prevention regulations – for working under a lifted load without additional support.



Model KHB 14  
Capacity 6000 kg

Model KHB 8  
Capacity 3000 kg



Option:  
Lifting beam for KHB 8

### Technical data model KHB

Model	Art.-No.	Capacity head kg	Claw kg	Height mm	Lifting height mm	Crank version	Gear	Weight kg
KHB 8	030077011	3000	3000	932	410	Sifeku	spur type	78
KHB 8	030080012	7500	7500	1105	500	Siku	spur type	128
KHB 14	040076015	6000	6000	1105	500	Siku	spur type	130

### Step height of adjustable lifting claw for model KHB

Model	Capacity kg	1. Step mm	2. Step mm	3. Step mm	4. Step mm	5. Step mm	6. Step mm	7. Step mm
KHB 8	3000	115	227	339	451	563	675	787
KHB 8	7500	275	460	645	830	1015	-	-
KHB 14	6000	275	460	645	830	1015	-	-

### Dimensions model KHB

Model	KHB 8	KHB 8	KHB 14
Art.-No.	030077011	030080012	040076015
B, mm	600	600	600
C, mm	400	400	400
D, mm	150	150	150
E, mm	120	120	120
F, mm	250	300	300
O/P, mm	100/120	159/180	150/180

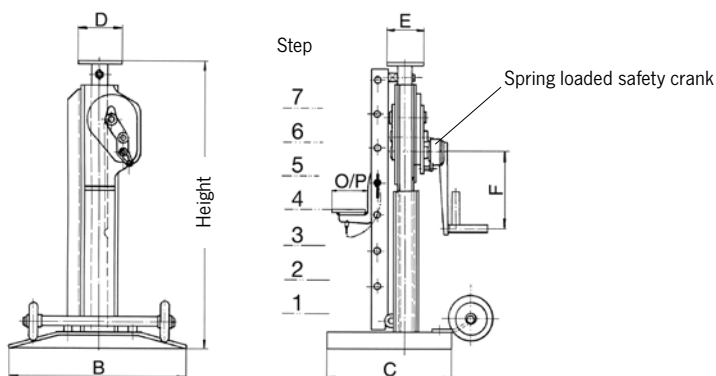





with ratchet

## Construction screw jack model BSW

Capacity 12000 - 30000 kg

The construction screw jack is ideally suited for supporting extremely large loads

### Features

- Self-locking spindle drive for precise levelling of loads.
- High-quality trapezoidal spindle for a long service life of the jack.

### Options

- Welded-on carrying handles for easy transport of the jack.
- Plug-in lever for reaching the required lifting height easily and quickly.
- Special lifting heights.

## Technical data model BSW

Art.-No. without ratchet	Art.-No. with ratchet	Capacity static t	Capacity dynamic t	Lift mm	Spindle diameter mm	Base plate mm	Head plates mm	Weight kg
031901001	031901044	12	10	200	50	220x220	120x120	21/22*
031902008	031902016	20	10	200	65	220x220	140x140	22/24*
031903004	031903012	30	5	177	85	300x300	140x140	46/48*

\*with ratchet

## Dimensions model BSW

Art.-No. without ratchet	031901001	031902008	031903004
Art.-No. with ratchet	031901044	031902016	031903012
A, mm	220	220	300
B, mm	120	140	140
C, mm	420	461	470
D, mm	220	240	240
Ø E, mm	25	33	33

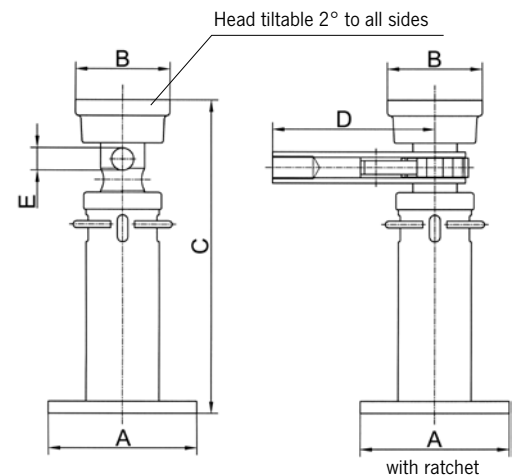

## Worm gear drive model S 20 and model S 24

The worm gear drives are suitable for a large variety of applications in construction for moving or turning loads, as gears for rope drums or chain sprockets or slewing drives.

### Features

- Enclosed housing for the protection of parts inside.
- Enclosed and precisely machined gear for little effort and a long service life.



Model S 20



Model S 24

### Technical data model S 20 & Modell S 24

Model	Art.-No.	Ratio	Drive torque daNm	Required crank effort daN	Shaft length mm	Shaft diameter mm	Hole spacing mm
S 20	032626004	20:1	12	11	196	25	5
S 24	032626020	24:1	36	22	200	36	5

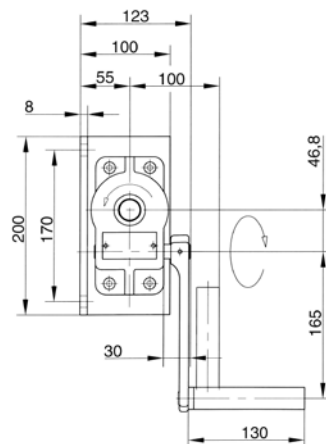
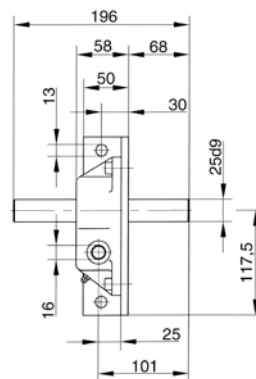
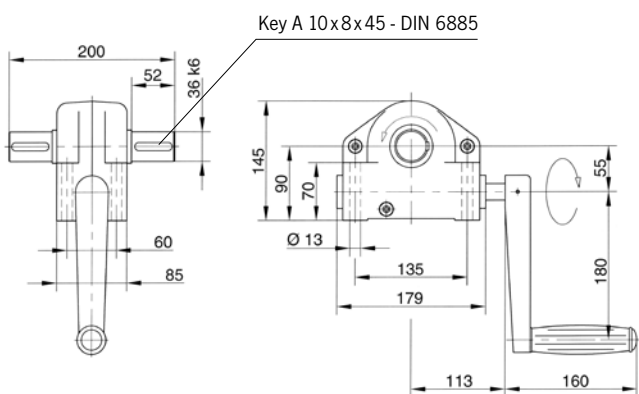

**This user information presents a general review regarding the application of cranes and does not substitute the existing operating instructions for specific products!**

**Lifting and slewing operations may be carried out by competent users (trained in theory and practice) only. When operated correctly, our cranes will offer the highest degree of safety in line with long life expectancy and avoid damage to products and people.**

Yalesystems cranes are manufactured in accordance with the machinery directive 89/392/EEC and the latest DIN 15018 H2 B2 (gantry cranes H2 B3) and correspond to the VDE regulations.

All components are mechanically shot blast, then primed and coated with RAL 1023 (yellow) paint, D.F.T. approx. 60 micron.

## Modification of delivery condition

Design and finish of the cranes may not be modified by e.g. installation of outside supplied parts, bending, welding, grinding, removal of parts, added bores, removal of safety devices like locking mechanisms, locking pins, safety latches etc.

## Limitations of operation

### Temperature

Cranes may normally be operated at ambient temperatures between  $-10^{\circ}\text{C}$  up to  $+50^{\circ}\text{C}$ . These values are approximate and may deviate from the specific givings of the product concerned. The accurate data are given in the current operating instructions.

### Chemicals

Cranes may not be operated without hesitation in the area of chemicals or chemical vapours – consult our specialists for advice. Cranes which have been subject to chemicals or vapours must be taken out of service and inspected by us.

## Transport of people

Transport of people with cranes is generally forbidden!

## Operation in danger zones

Lifting or transport of loads must be avoided while personnel are in the danger zone. People are not allowed to pass over or under a suspended load.

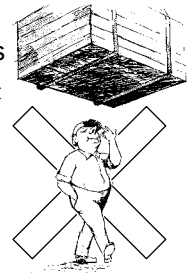

## Electrical hazards

Please consult the specific operating instructions for possible electrical hazards. Electrical connections may only be performed by authorized persons resp. companies!

## Maintenance and repair

To ensure safe operation, all cranes must be subjected to regular inspections according to the maintenance instructions given by the manufacturer (for legal obligations refer to BGVD6).

Depending on the frequency and impact of applications, the crane has to be maintained, at least once per year or in case of obvious damages, by competent persons resp. inspectors.

Repairs and inspections may only be carried out by competent persons resp. inspectors who use original spare parts. Repairs and inspections must be recorded consecutively.

## Inspections

The contractor has to make sure that powered cranes are inspected prior to initial operation and after significant modifications by a competent person. This is also applicable for hand operated cranes with a capacity of more than 1000 kg.

For cranes according to § 3a para. 3 BGV D 6 the inspection before initial operation consists of advance survey, inspection of building and quality acceptance.

The inspection prior to initial operation is not required for cranes, which are delivered ready-to-use and with certificate of a type approval or EC declaration of conformity.

**For information on training please see page 4-5.**

Technical questionnaire for choosing the suitable crane system

Company: \_\_\_\_\_

Date: \_\_\_\_\_

Contact: \_\_\_\_\_

e-Mail: \_\_\_\_\_

Phone: \_\_\_\_\_

Fax: \_\_\_\_\_

- Wall-mounted jib crane
- Floor-mounted jib crane
- For outdoor use

Capacity (max.) \_\_\_\_\_ kg  
 Slewing range \_\_\_\_\_  
 Boom length A \_\_\_\_\_ mm  
 Boom clearance UK \_\_\_\_\_ mm  
 or: ceiling clearance H \_\_\_\_\_ mm  
 or: overall height B \_\_\_\_\_ mm  
 or: highest hook position \_\_\_\_\_ mm

**Accessories**

- Increased paint thickness
- Hot-dip galvanizing
- Boom locks
- Slewing range stoppers
- Electrically driven slewing gear
- Slewing brake

**Power supply**

- Round cable
- Festooned cable
- Suspended control

**Mounting for wall-mounted jib crane**

- Threaded rods/anchor bolts
- Pillar embracing

**Mounting for floor-mounted jib crane**

- Anchors and template
- Standard base plate (welded) incl. anchors/rawplug
- Dowel base plate (bolted) incl. anchors/rawplug

**Hoists**

- Manual hoists
- Electric chain hoist (single speed)
- Electric chain hoist (2 speeds)

- Gantry crane

Capacity (max.) \_\_\_\_\_ kg  
 Gantry width – inside – a \_\_\_\_\_ mm  
 Gantry width – outside – A \_\_\_\_\_ mm  
 Beam clearance UK \_\_\_\_\_ mm  
 or: ceiling clearance H \_\_\_\_\_ mm  
 or: overall height B \_\_\_\_\_ mm  
 or: highest hook position \_\_\_\_\_ mm

**Accessories**

- Increased paint thickness
- Hot-dip galvanizing

**Power supply**

- Round cable
- Festooned cable
- Suspended control

**Trolleys**

- With pushed trolley
- With geared trolley
- With electric trolley (single speed)
- With electric trolley (2 speeds)



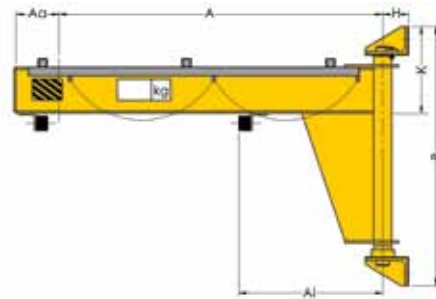
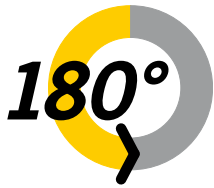

**!** Mounting supports and walls are within the responsibility of the user.

### Scope of delivery

- The electrical system is equipped with a lockable main switch, round cable power supply with cable support pipes for booms up to 4000 mm.
- From 4500 mm upwards, the boom is equipped with a festooned cable power supply. Due to cable sag on low cranes, we recommend the use of festooned cables even on short booms.
- Trolley stoppers at the front and at the back.
- Cranes are supplied with an operating manual and complete manufacturer's documentation.

## Wall-mounted jib crane model PMS

Elevated boom with optimal height, slewing range 180°

Lightweight, twist-free steel girder construction with low headroom. The boom is fitted with a bearing and a wall bracket for anchoring the crane to a concrete wall.

Mounting a jib crane to a wall, in combination with a festooned cable system, may lead to restrictions in the slewing range of the boom. This being the case, slew stoppers (buffers) should be fitted accordingly.

### Mounting

- Wall mounting, using threaded rods that go through the wall and that are bolted to the wall with counter plates and nuts.
- Pillar embracing with anchor bolts and wall bracket. Bracket plate max. 500 mm, anchor bolts (threaded rods) max. 1000 mm.
- Alternative mounting systems on request.

### Options

- Slew stoppers (buffers) can be fitted on building site for a pre-determined fixed slewing range.
- Slewing brake, to control the boom speed during slewing. Recommended for a boom length of more than 5 m or a headroom of more than 4 m. This prevents uncontrolled movement of the boom.
- Increased paint layer (120µm) or hot-dip galvanisation for outdoor use.
- Manual locking device, to hold the boom in a fixed position (wind protection).
- Hoist cover for outdoor use.

## Standard delivery programme model PMS

Model	Capacity kg	Boom length in mm										
		2000	2500	3000	3500	4000	4500	5000	5500	6000	6500	7000
PMS 50	50	•	•	•	•	•	•	•	•	•	•	•
PMS 80	80	•	•	•	•	•	•	•	•	•	•	•
PMS 125	125	•	•	•	•	•	•	•	•	•	•	•
PMS 200	200	•	•	•	•	•	•	•	•	•	•	•
PMS 250	250	•	•	•	•	•	•	•	•	•	•	•
PMS 400	400	•	•	•	•	•	•	•	•	•	•	•
PMS 500	500	•	•	•	•	•	•	•	•	•	•	•
PMS 800	800	•	•	•	•	•	•	•	•	•	•	•
PMS 1000	1000	•	•	•	•	•	•	•	•	•	–	–
PMS 1600	1600	•	•	•	•	•	•	•	–	–	–	–
PMS 2000	2000	•	•	•	•	•	–	–	–	–	–	–
PMS 2500	2500	•	•	•	–	–	–	–	–	–	–	–

Mounting systems wall-mounted jib cranes

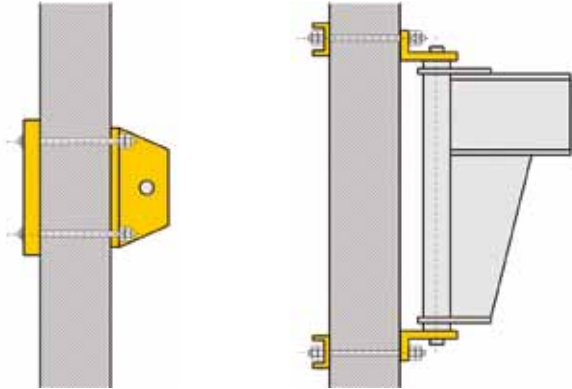

Wall mounting, using threaded rods going through the wall and being fixed to the wall with counter plates and nuts.

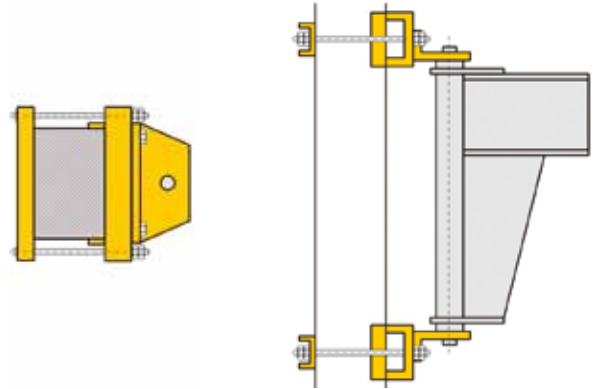

Pillar embracing with anchor bolts and wall bracket (bracket plate max. 500 mm, anchor bolts max. 1000 mm)

Further fastening possibilities such as weld-on brackets, ceiling mounting etc. on request.

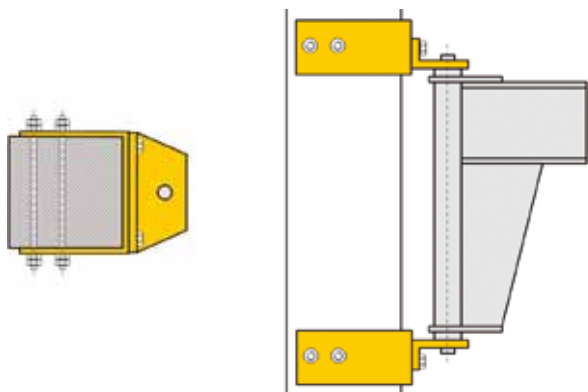
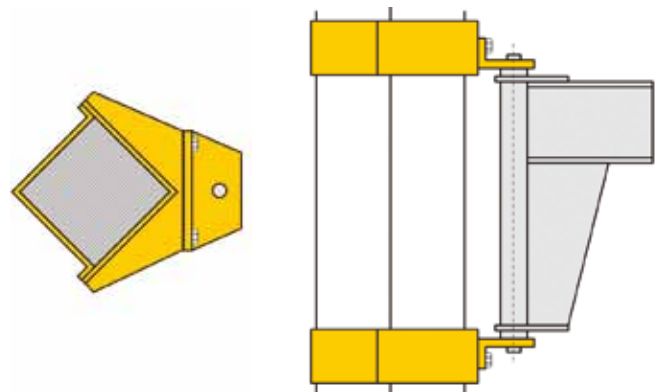
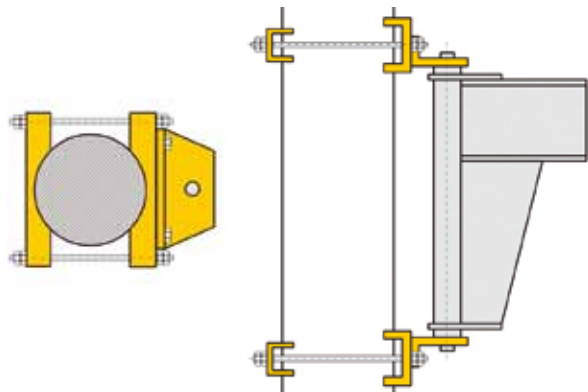

If wall-mounted jib cranes are mounted directly to the wall, and a festooned cable power supply is used, the slewing range may be limited, depending on the size of the hoist.



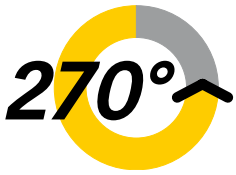

## Floor-mounted jib crane model PFSP

Elevated boom with optimal height, slewing range 270°

Lightweight, twist-free steel girder construction with low headroom. The boom is fitted with a bearing, pillar made from reinforced steel pipe.

Depending on the size of the hoist and in combination with festooned power cables, restrictions in the slewing range of the boom may be possible.

### Mounting

- Base flange with anchor bolts and template.
- Anchoring the base plate (welded) including mortar cartridges, anchor studs (complete with nuts, locknuts and washers).
- Anchoring the dowel base plate (bolted) including mortar cartridges, anchor studs (complete with nuts, locknuts and washers).
- Mobile unit for changeable location.

### Options

- Slew stoppers (buffers) can be fitted on building site for a pre-determined fixed slewing range.
- Slewing brake, to control the boom speed during slewing. Recommended for a boom length of more than 5 m or a headroom of more than 4 m. This prevents uncontrolled movement of the boom.
- Increased paint layer (120 µm) or hot-dip galvanisation for outdoor use.
- Manual locking device, to hold the boom in a fixed position (wind protection).
- Hoist cover for outdoor use.

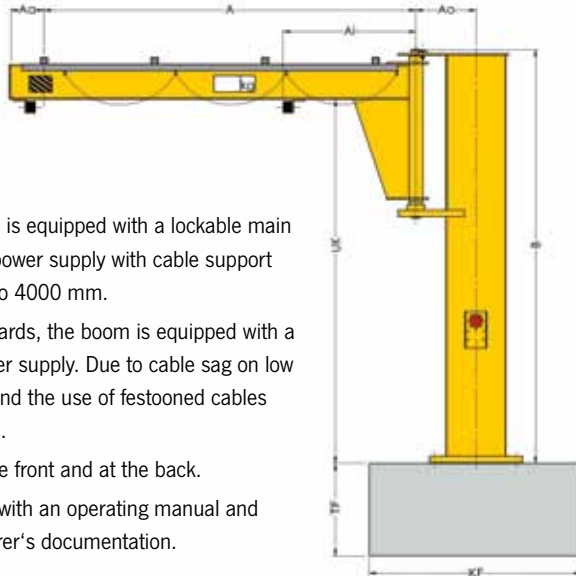

### Scope of delivery

- The electrical system is equipped with a lockable main switch, round-cable power supply with cable support pipes for booms up to 4000 mm.
- From 4500 mm upwards, the boom is equipped with a festooned cable power supply. Due to cable sag on low cranes, we recommend the use of festooned cables even on short booms.
- Trolley stoppers at the front and at the back.
- Cranes are supplied with an operating manual and complete manufacturer's documentation.

**Mounting systems, please see page 139.**

## Standard delivery programme model PFSP

Model	Capacity kg	Boom length in mm										
		2000	2500	3000	3500	4000	4500	5000	5500	6000	6500	7000
PFSP 50	50	•	•	•	•	•	•	•	•	•	•	•
PFSP 80	80	•	•	•	•	•	•	•	•	•	•	•
PFSP 125	125	•	•	•	•	•	•	•	•	•	•	•
PFSP 200	200	•	•	•	•	•	•	•	•	•	•	•
PFSP 250	250	•	•	•	•	•	•	•	•	•	•	•
PFSP 400	400	•	•	•	•	•	•	•	•	•	•	•
PFSP 500	500	•	•	•	•	•	•	•	•	•	•	•
PFSP 800	800	•	•	•	•	•	•	•	•	•	•	•
PFSP 1000	1000	•	•	•	•	•	•	•	•	•	–	–
PFSP 1600	1600	•	•	•	•	•	•	•	–	–	–	–
PFSP 2000	2000	•	•	•	•	•	–	–	–	–	–	–
PFSP 2500	2500	•	•	•	–	–	–	–	–	–	–	–

## Floor-mounted jib crane model PFM

Elevated boom with optimal height, slewing range 360°

Lightweight, twist-free steel girder construction with low headroom. Compact rotating head for ideal construction dimensions; access from above ensures easy assembly. The boom is fitted with a roller bearing, pillar made from reinforced steel pipe.

Depending on the size of the hoist and in combination with festooned power cables, restrictions in the slewing range of the boom may be possible.

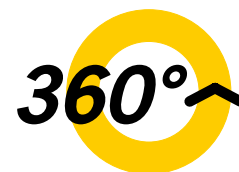

### Mounting

- Base flange with anchor bolts and template.
- Anchoring the base plate (welded) including mortar cartridges, anchor studs (complete with nuts, locknuts and washers).
- Anchoring the dowel base plate (bolted) including mortar cartridges, anchor studs (complete with nuts, locknuts and washers).
- Mobile unit for changeable location.

### Options

- Slew stoppers (buffers) can be fitted on building site for a pre-determined fixed slewing range.
- Slewing brake, to control the boom speed during slewing. Recommended for a boom length of more than 5 m or a headroom of more than 4 m. This prevents uncontrolled movement of the boom.
- Increased paint layer (120µm) or hot-dip galvanisation for outdoor use.
- Manual locking device, to hold the boom in a fixed position (wind protection).
- Hoist cover for outdoor use.

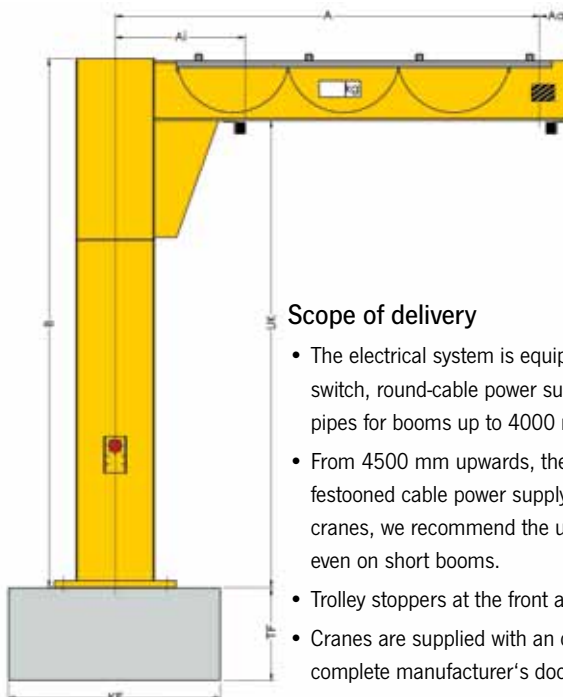

### Scope of delivery

- The electrical system is equipped with a lockable main switch, round-cable power supply with cable support pipes for booms up to 4000 mm.
- From 4500 mm upwards, the boom is equipped with a festooned cable power supply. Due to cable sag on low cranes, we recommend the use of festooned cables even on short booms.
- Trolley stoppers at the front and at the back.
- Cranes are supplied with an operating manual and complete manufacturer's documentation.

**!** Mounting systems, please see page 139.

### Standard delivery programme model PFM

Model	Capacity kg	Boom length in mm										
		2000	2500	3000	3500	4000	4500	5000	5500	6000	6500	7000
PFM 50	50	•	•	•	•	•	•	•	•	•	•	•
PFM 80	80	•	•	•	•	•	•	•	•	•	•	•
PFM 125	125	•	•	•	•	•	•	•	•	•	•	•
PFM 200	200	•	•	•	•	•	•	•	•	•	•	•
PFM 250	250	•	•	•	•	•	•	•	•	•	–	–
PFM 400	400	•	•	•	•	•	•	•	–	–	–	–
PFM 500	500	•	•	•	•	•	•	–	–	–	–	–
PFM 800	800	•	•	•	–	–	–	–	–	–	–	–
PFM 1000	1000	•	•	–	–	–	–	–	–	–	–	–

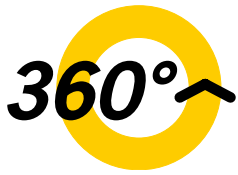

Further capacities and boom lengths on request.



## Floor-mounted jib crane model PFP

Elevated boom with optimal height, slewing range 360°

Heavy, robust twist-free steel girder construction. Structural steel crane-boom. Compact rotating head for ideal construction dimensions; access from above ensures easy assembly. The boom is fitted with a roller bearing, pillar made from reinforced steel pipe.

Depending on the size of the hoist and in combination with festooned power cables, restrictions in the slewing range of the boom may be possible.

### Mounting

- Base flange with anchor bolts and template.
- Anchoring the dowel base plate (bolted) including mortar cartridges, anchor studs (complete with nuts, locknuts and washers).

### Options

- Electrically driven slewing gear.
- Slew stoppers (buffers) can be fitted on building site for a pre-determined fixed slewing range.
- Limit switches to limit the boom slewing range (before hitting a fixed object the motor switches off automatically).
- Increased paint layer (120µm) or hot-dip galvanisation for outdoor use.
- Manual locking device, to hold the boom in a fixed position (wind protection).
- Hoist cover for outdoor use.

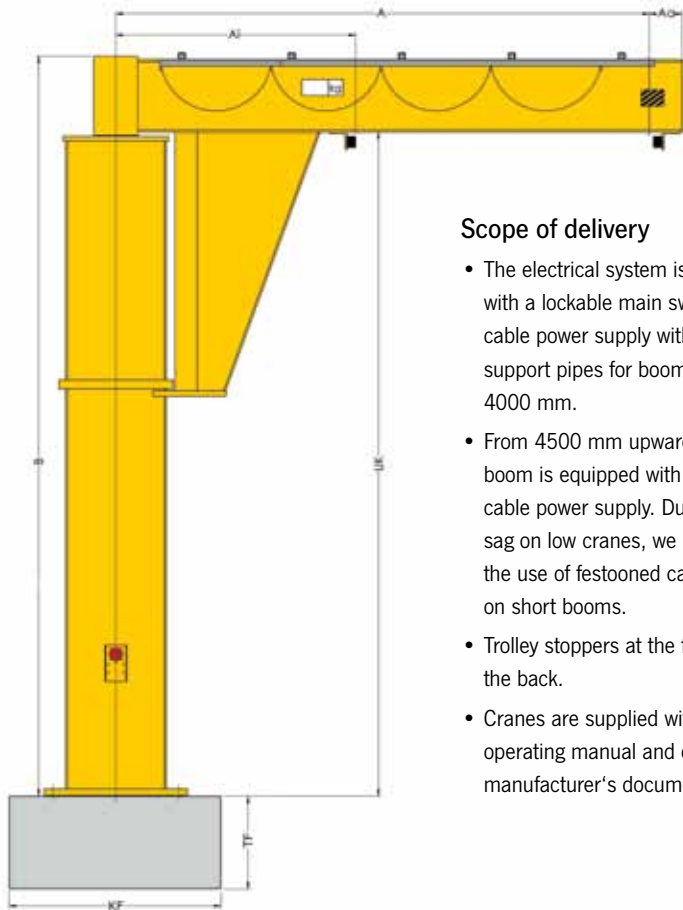

### Scope of delivery

- The electrical system is equipped with a lockable main switch, round-cable power supply with cable support pipes for booms up to 4000 mm.
- From 4500 mm upwards, the boom is equipped with a festooned cable power supply. Due to cable sag on low cranes, we recommend the use of festooned cables even on short booms.
- Trolley stoppers at the front and at the back.
- Cranes are supplied with an operating manual and complete manufacturer's documentation.

Mounting systems, please see page 139.

## Standard delivery programme model PFP

Model	Capacity kg	Boom length in mm										
		2000	2500	3000	3500	4000	4500	5000	5500	6000	6500	7000
PFP 500	500	•	•	•	•	•	•	•	•	•	•	•
PFP 800	800	•	•	•	•	•	•	•	•	•	•	•
PFP 1000	1000	•	•	•	•	•	•	•	•	•	•	•
PFP 1600	1600	•	•	•	•	•	•	•	•	•	•	–
PFP 2000	2000	•	•	•	•	•	•	•	•	•	–	–
PFP 2500	2500	•	•	•	•	•	•	•	–	–	–	–
PFP 3200	3200	•	•	•	•	•	–	–	–	–	–	–

### Safety distances in accordance with the accident prevention regulations for cranes (BGV D6) para. 11/para. 32

The following safety distances are only valid for floor-controlled cranes, without platforms, walkways or similar, on the jib with a load capacity of less than 10 t.

Movement manual	Safety distance		
	So = Top	Ss = Side	Su = Bottom
Lifting	100*	100*	100*

Movement power-driven, floor-controlled	Safety distance		
	So = Top	Ss = Side	Su = Bottom
Lifting	100*	100*	100*
Lifting and travelling	100*	100*	500
Lifting, travelling and slewing	100*	100* (500)	500

Safety distances for cranes with a load capacity up to 10000 kg  
 \*No regulation (100 mm recommended)

Ss... for power-driven slewing motion, the safety distance must be complied with, if the possible crushing point is within the traffic and working area.

In general, the traffic and working area ranges from the upper edge of the ground up to 2.5 m room height.

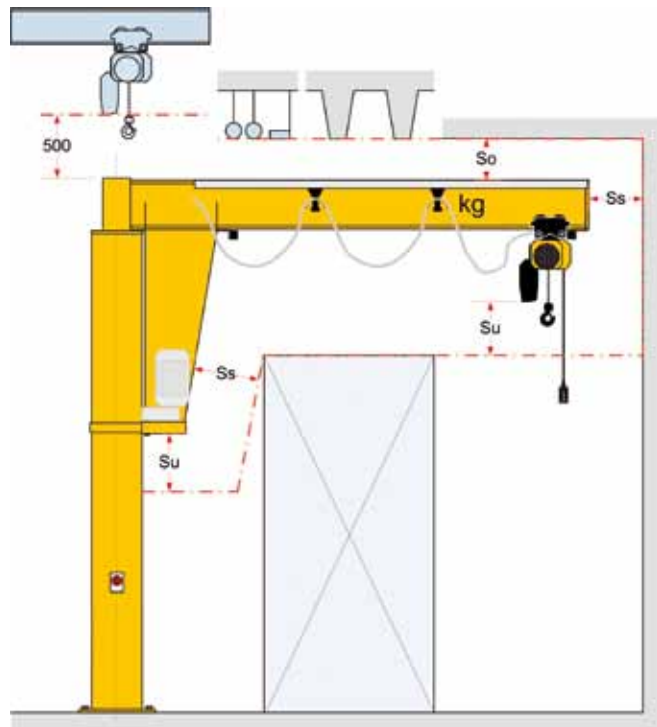

**If wall-mounted jib cranes are mounted directly on the wall and festooned cable power supply is used, the slewing range may be limited depending on the size of the hoist.**

### Mounting systems for floor-mounted jib cranes

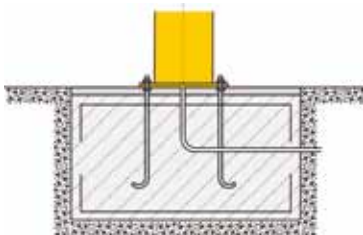

Anchor bolts with template for preparation of the foundation through the customer.

**Further fastening possibilities such as weld-on brackets, ceiling mounting etc. on request.**

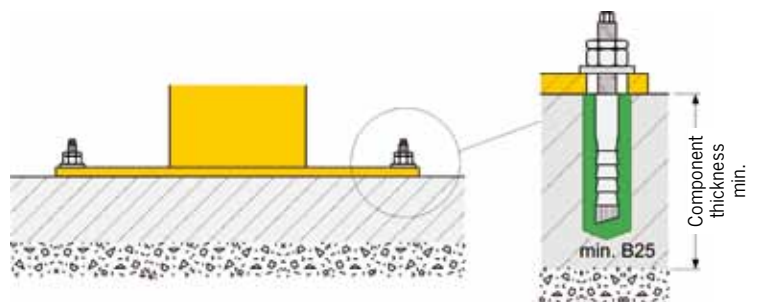

Standard base plate (welded) for anchor-bolt connection on existing concrete floor instead of welded-on base flange (only for operation inside a building) incl. HVZ dynamic anchor bolts.

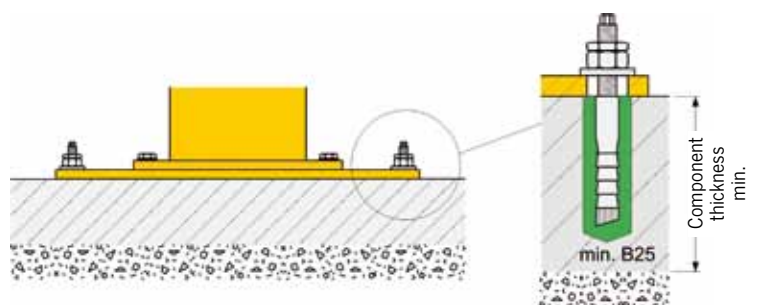

Dowel base plate for anchor-bolt connection on existing concrete floor (only for operation inside a building) incl. HVZ dynamic anchor bolts.

## Operating conditions for standard and intermediate base plates

- The thickness of the concrete floor slab for M 12x95 HVC dynamic anchor bolts must be min. 190 mm.
- The thickness of the concrete floor slab for M 16x105 HVC dynamic anchor bolts must be min. 210 mm.
- The concrete floor slab must be horizontal and even.
- The concrete quality must meet min. B25 or C20/25.
- Mounting with through bolts consisting of base plate, through bolts and counter plates (for ceiling thicknesses up to 350 mm).
- Floor/wall mounting or floor/ceiling mounting on request.

**If floor-mounted jib cranes are mounted directly on the wall and festooned cable power supply is used, the slewing range may be limited depending on the size of the hoist.**

**Due to cable sag, we recommend that on low cranes festooned cables be used, even for a short boom length.**

## Base plate for fastening pillar-mounted slewing jibs and slewing cranes without foundation

Some pillar-mounted slewing jibs and slewing cranes can be mounted by means of a standard base plate or an dowel base plate.

No foundation is required, easy and quick assembly on the customer's existing reinforced concrete slab is possible. **Potential tripping hazard by protruding locknuts, unmarked or unsecured plate edges must be clearly marked.**

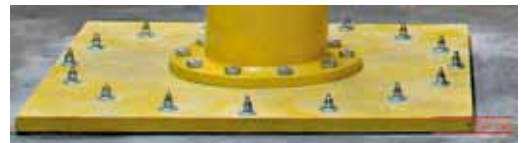

- The installation location of the crane must be selected in such a way that the base plate is mounted outside of traffic routes according to the German regulations for workplaces AStV para. 2. If this is not possible, the plate must be secured or marked in such a way that a hazard is avoided (e.g. by warning hatching along the edge of the plate).
- The base plate with tripping points must not protrude into escape routes or limit their prescribed min. widths.
- The measures for reducing hazards caused by tripping points must be taken by the operating company in cooperation with the safety expert.
- A warning sign as hazard reduction is a minimal measure and may not be sufficient in certain cases (e.g. in spite of warning signs, tripping incidences occur frequently, the warning sign is not recognised sufficiently in advance).

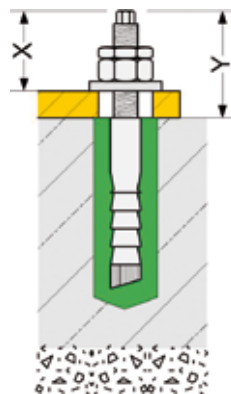

The smallest possible projection of the chemical anchor over the crane base plate "X" with an M12 anchor is approx. 33 mm, with M16 approx. 37 mm. This dimension can only be reached, if the concrete floor slab exceeds the above-mentioned min. thickness. The max. projection of the chemical anchor, measured

from floor level "Y", is approx. 73 mm for M12 anchors and approx. 86 mm for M16 anchors, with the relevant min. floor slab thickness.

**Plate dimensions, quantity, dimension and position of the chemical anchors depend on the crane type, load capacity and boom length of the crane (details and technical data according to the relevant crane data sheet).**



### Moveable gantry crane model TD

Yalesystems gantry crane for use in all areas, from craftsman's workshops, garages and industrial use. They are suitable for low to medium weight capacities and are also for outdoor use.

The cranes are moved by hand and are not dependant on a rail system.

The guidelines for moving Yalesystems gantry cranes and transporting loads should be strictly followed.

#### Options

- Increased paint layer (120µm) or hot-dip galvanisation for outdoor use.
- Hoist cover for outdoor use.

#### Scope of delivery

- 3-part construction with 2 robust rectangular steel-bar supports and 1 load carrier beam.
- Manually moveable, parking brake by threaded spindle.
- Power supply by festooned cables incl. flat cables, C type mounting rail, cable trolley, support arms and towing trolleys.
- Cranes are supplied with an operating manual and complete manufacturer's documentation.



**!** Further capacities and boom lengths on request.

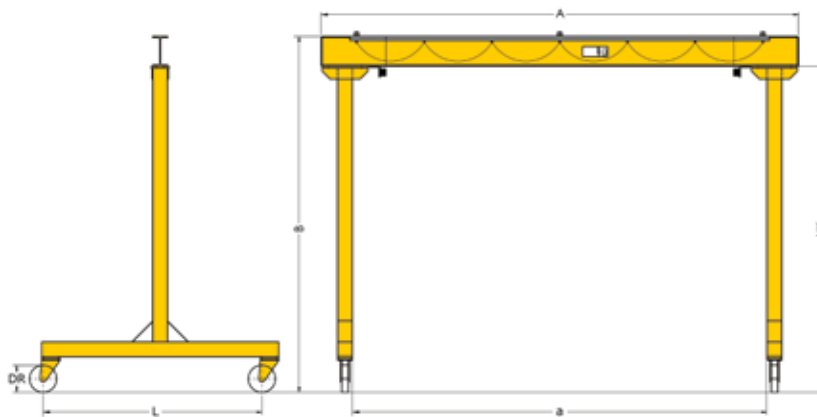

### Standard delivery programme model TDL

Model	Capacity kg	Boom length in mm							
		2500	3000	3500	4000	4500	5000	5500	6000
TDL 500	500	•	•	•	•	•	•	•	•
TDL 1000	1000	•	•	•	•	•	•	•	•
TDL 2000	2000	•	•	•	•	•	•	•	•
TDL 3200	3200	•	•	•	•	•	•	•	•

Boom clearance (UK): Standard 2500 mm, other dimensions on request.

Gantry width - inside (dimension a):

TDL-500/TDL-1000: Boom length A minus 455 mm  
 TDL-2000/TDL-3000: Boom length A minus 500 mm



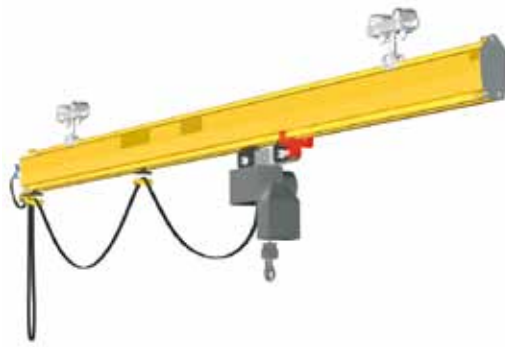

## Monorail model YSK-ES

Capacity 80 - 2000 kg

The monorail is adapted to our range of hoisting equipment and offers versatile solutions for lifting and moving loads. Standard connections and fastening arrangements ensure easy assembly.

The modular design enables modifications required by changing production conditions to be carried out easily and quickly.

### Technical data model YSK-ES

Profile YSK-ES	Overall height adjustable mm	Suspension spacing for monorail $l_w$ m	Capacity in kg						
			80	125	250	500	1000	1600	2000
100 I	220	3.0	2.4						
	250		5.0	4.1	2.5				
II-L II	370	7.0	5.8	3.5					
	400		8.0	5.4	3.2				
III	446		8.0	5.7	4.1	3.4			

## Single-girder crane model YSK-ET

Capacity 80 - 2000 kg

Single-girder cranes of the YSK-ET model range are user-friendly cranes with a large operating radius. Swaying of the load is reduced, since the push-type trolley automatically aligns to the optimal lifting position.

The three-dimensional design and its low deadweight contribute to providing ergonomic solutions to lifting tasks at the workplace.



### Technical data model YSK-ET

Profile YSK-ET		Capacity in kg						
		80	125	250	500	1000	1600	2000
100	Span $l_{KT}$	2.85	2.6					
100	Girder length $l_{HT}$	3.0	3.0					
I	Span $l_{KT}$	4.65	4.6	2.75				
	Girder length $l_{HT}$	6.0	5.0	3.0				
II-L	Span $l_{KT}$		7.0	6.1	3.7			
	Girder length $l_{HT}$		8.0	7.0	4.0			
II	Span $l_{KT}$			7.45	5.9	3.5		
	Girder length $l_{HT}$			8.0	7.0	4.0		
III	Span $l_{KT}$				8.4	6.3	4.3	3.6
	Girder length $l_{HT}$				9.0	7.0	5.0	4.0



## Double-girder crane model YSK-ZT

Capacity 80 - 3200 kg

Double-girder cranes of the YSK-ZT model range are also suitable for heavy loads owing to their wide load capacity range. The position of the hoist between the bridge profile sections ensures maximum utilization of the lifting height.



### Technical data model YSK-ZT

Profile YSK-ZT		Capacity in kg							
		80	125	250	500	1000	1600	2000	3200
100	Span $I_{KT}$	4.4	3.8						
100	Girder length $I_{HT}$	5.0	5.0						
I	Span $I_{KT}$		6.2	5.0	3.1				
I	Girder length $I_{HT}$		9.0	6.0	4.0				
II-L	Span $I_{KT}$			7.6	6.5	4.3			
II-L	Girder length $I_{HT}$			10.0	7.0	5.0			
II	Span $I_{KT}$				8.8	6.1	4.6	3.6	
II	Girder length $I_{HT}$				11.0	7.0	5.0	4.0	
III	Span $I_{KT}$					9.1	7.4	6.3	4.2
III	Girder length $I_{HT}$					14.0	9.0	7.0	5.0

Single-girder and double-girder cranes can either be fitted to the ceiling structure or to free-standing supporting frames.

A further application is the use of an existing rack structure as the supporting structure for single-girder suspension cranes. This application is not only more economical than a free-standing supporting structure but also enables the system to be used without an existing roof profile sections.

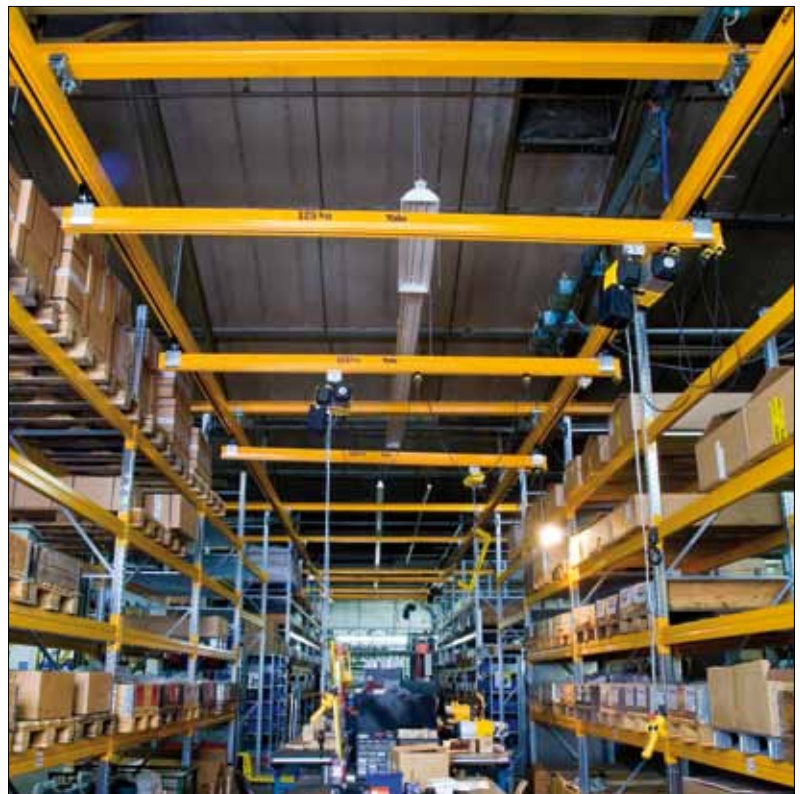

## Festooned cable system

The Yale festooned cable system kit contains all the parts necessary to install a power supply.

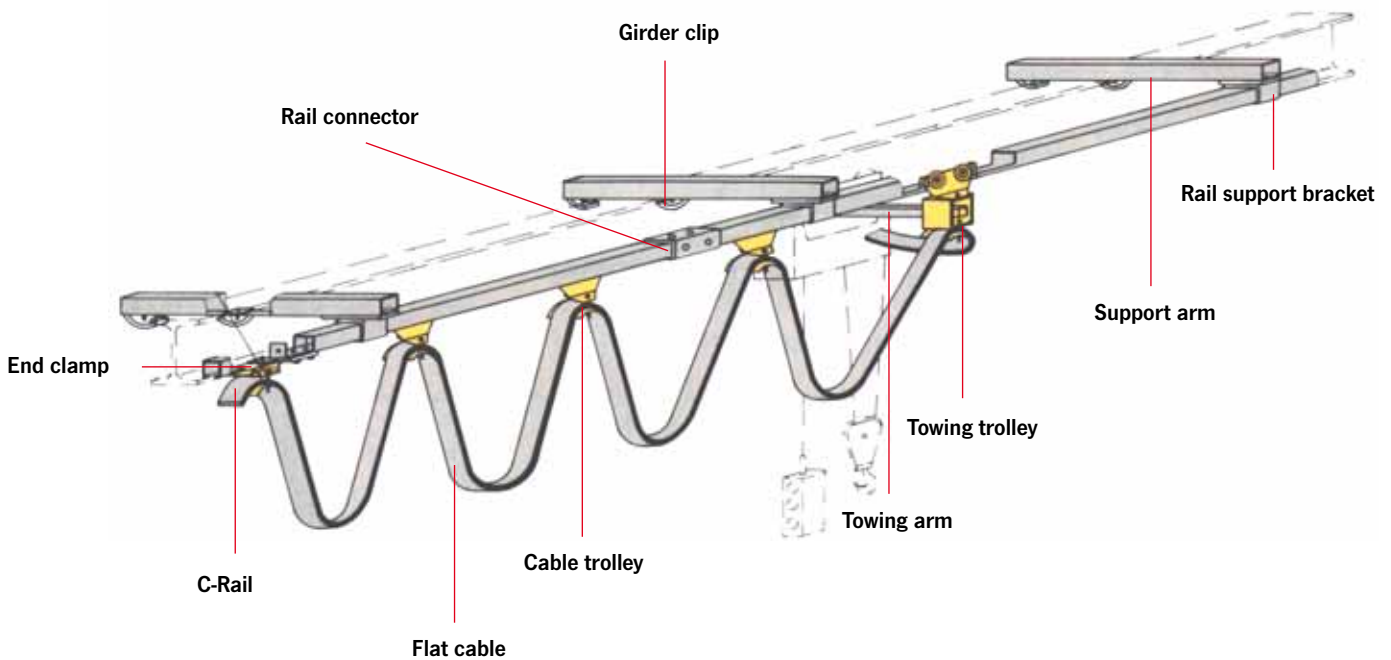

### Features

- The PVC flat cable 4 x 2.5 mm<sup>2</sup> is suitable for all electric hoists with a power consumption of up to 25 A.
- The line sag is 700 mm. The cable and towing trolleys are made from plastic and can withstand loads of up to 10 daN.
- The rollers are fitted with bronze bushes resp. ball bearings.
- The C-rail, rail support brackets and rail connectors are zinc-plated for added protection against corrosion.

### Options

- Mounting kit consisting of support arm and girder clips for connection to the beam.
- Towing arm for towing trolley.

### Scope of delivery

- 1 End clamp
- 1 End stop
- 1 Towing trolley
- 2 End caps
- 2 FI-fittings with locknuts
- 1 Main switch 400V, 50 Hz



Main switch

**!** Quantity of units dependant on track length.

## Scope of delivery festooned cable systems

Model	EAN-No. 4025092*	EAN-No. Mounting kit 4025092*	C-rails track length m	Transport distance max. m	PVC flat cable m	Numbers of cable trolleys	Rail support bracket	Rail connector
Festooned cable 4.0 m C-rail track length	*059305	*059398	4	3.5	9	2	4	0
Festooned cable 6.0 m C-rail track length	*059312	*059404	6	5.4	11	3	5	1
Festooned cable 8.0 m C-rail track length	*059329	*059411	8	7.3	13	5	6	1
Festooned cable 10.0 m C-rail track length	*059336	*059428	10	9.2	15	6	7	2
Festooned cable 12.0 m C-rail track length	*059435	*059435	12	11.0	17	8	8	2
Festooned cable 14.0 m C-rail track length	*059442	*059442	14	12.9	19	9	9	3
Festooned cable 16.0 m C-rail track length	*059459	*059459	16	14.8	21	11	10	3
Festooned cable 18.0 m C-rail track length	*059466	*059466	18	16.7	23	12	11	4
Festooned cable 20.0 m C-rail track length	*059473	*059473	20	18.5	25	14	12	4



Cable trolley



Towing trolley



Rail support bracket



Rail connector



C-Rail

**Special applications e.g. for curves or cable trolley for round cables on request.**

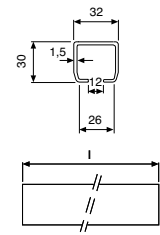
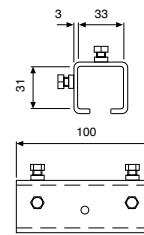
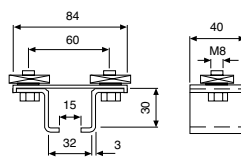
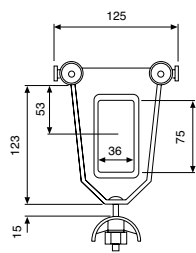
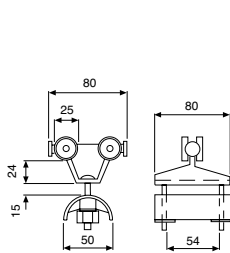

**Optional: Mounting kit consisting of support arm and girder clips for connection to the beam.**

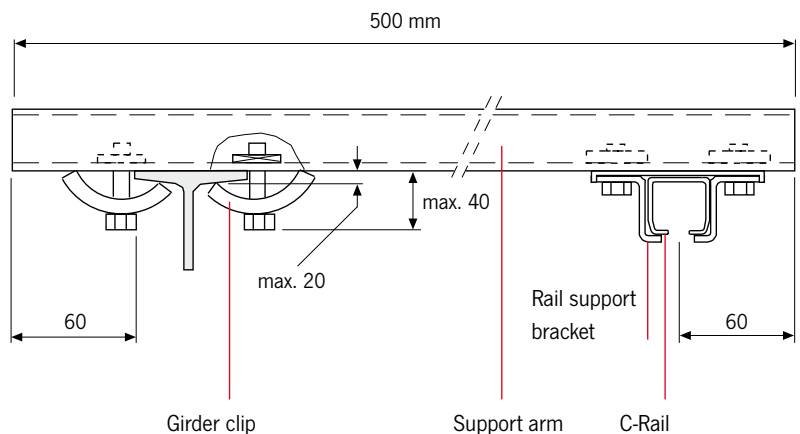





**Tigrip® Crane Weighers**  
Crane weighers and load indicator for reliable measurement

Crane Weighers



**Grabs & Clamps**  
for the transport of sheet metal, steel plates, profiles and steel constructions



Load indicator



Screw clamps



Permanent load lifting magnets



Crate grabs in various designs

**!** Please note our user instructions at the beginning of each chapter.

## Tigrip® Load Hoisting Tackle

Lifting clamps and attachments have a reputation for reliability, quality and safety going back more than 35 years. For transportation and handling of loads with a hoist the Tigrip® programme offers the optimum connection between hook and load for almost any application.

## Tigrip® Crane Weighers

Also renown for many years are our precise crane weighers. Wherever weight has to be measured or forces have to be assessed the reliable and robust units can be used. Areas of application are practically unlimited.

Tigrip® your first choice.

## Table of Contents

	Page
Grabs & Clamps	152 - 161 164 - 189
Permanent load lifting magnets	162 - 163
Container lifting lugs & C-Hooks	190 - 194
Barrel grabs & Crate grabs	195 - 201
Load hoisting tackle for underground construction	202 - 205
Clamps & Tine hooks	206 - 207
Spreader beams	208 - 215
Crane forks	216 - 217
Crane weighers	218 - 221



**Load hoisting tackles for underground construction**



**Spreader beams**  
in various standard and customised designs



**Crane forks**  
for transporting pallets



**This user information presents a general overview regarding the operation of some plate clamps and does not substitute the existing operating instructions for specific load hoisting tackle!**

**Lifting operations with load hoisting tackle may be carried out by competent persons (trained in theory and practice) only.**

**When operated correctly, our Tigrip products will offer the highest degree of safety, avoid damage to products and people and present a long life expectancy.**

## Modification of delivery condition

Design and construction of the load hoisting tackle may not be altered without authorization of the manufacturer, e.g. by bending, welding, grinding, cutting-off parts, adding boreholes, removal of safety devices like locking mechanisms, bolts, shear pins etc. Otherwise the validity of the declaration of conformity will be void and any liability and warranty of the manufacturer ceased.

## Limitations of operation

### Loading

The rated capacity (WLL) indicated on the tackle is the maximum load which must not be exceeded.

### Temperature

Clamps without protective lining may normally (depending on manufacturer) be operated at ambient temperatures of -40° up to +100° C without capacity reduction. Clamps with protective lining may be subject to reduced temperature areas due to application of affixed linings, e.g. model TBP and TSB, which can be operated from -20° up to +40° C.

### Shock loading, swinging of load

The indicated capacities are based on shock-free loading of the tackle. Light bumps as occurred during lifting and lowering as well as transporting of load with the crane are admitted. Heavier shock loadings (e.g. crashing against obstacles during transport) as well as swinging of the load are strictly forbidden!

### Chemicals

Load hoisting tackle may not be operated without hesitation in the area of chemicals or chemical vapours – consult our specialists beforehand. Hoisting tackle which has been subject to chemicals or vapours must be taken out of service and should be returned to us for inspection.

## Transport of people

Transport of people with hoisting equipment and tackle is generally forbidden!

## Operation in danger zones

Lifting or transport of loads must be avoided while personnel are in the danger zone. When using clamps or grabs without a positive fit but with force fit or friction fit the load must not be suspended above people – see AMVO §18(6)!

## Lifting products

Load hoisting tackle have been designed for specific applications and must not be used for other jobs without prior authorization of the manufacturer. This refers e.g. to the thickness of material (jaw capacity of the clamp), surface condition, hardness\* and temperature of material. Relative information is given in the respective operating instructions. These have to be available to the operator to ensure safe handling of the product.

\*Please observe that for special steel plates the surface hardness may deviate substantially from the core hardness, e.g. for cold work steel.

## Inspection before initial operation

- Ensure that the surface of the steel plate, in the area where the clamp is to be attached, is dry and free from grease, paint, dirt and scale and is not coated, so that the teeth resp. the protective lining on the moving jaw can make good contact with the surface of the load.
- Check the fixed jaw and the moving jaw for wear and defects. Both jaws must have clean profiles and teeth must not be heavily worn (observe respective advice given in the operating instruction, guiding value max. 30% wear). Protective linings must not be contaminated, damaged, uneven or heavily worn.
- The entire hoisting tackle has to be checked for damage, corrosion, cracks or deformations.
- It should be easy to open and close the clamp.
- Check the function of the spring. In the CLOSED position this must present a noticeable spring pressure force when the hook ring is pressed down.

## Application advice

- Load hoisting tackle must always be in perfect condition and provided with a legible identity plate.
- Prior to initial operation and every time before work, the tackle is to be visually inspected for obvious deficiencies!
- The suspension eye must have sufficient space in the load hook and move freely. A safety latch to prevent accidental out-hooking of the tackle must be available!
- Do not lift or transport loads while personnel are in the danger zone and do not allow people to pass under a suspended load. Note: a safe form-fit attachment requires sufficient hardness of the load. Ensure that the load or parts thereof cannot slip and fall down!
- The load hoisting tackle must be positioned over the gravity centre of the load, so that a swinging movement is avoided.
- If longer sheets of metal or profiles are to be transported, we recommend using two clamps to prevent load swinging. The clamps can be used in combination with a spreader beam or with double strand chain slings and clamps with hinged hook ring (e.g. model TBS). Observe the maximum angle from the vertical and possible capacity restrictions.
- Clamps without hinged hook ring must not be loaded laterally! (Slanted attachment of the clamp onto the steel plate in pulling direction of the clamp is normally not permitted, as the jaws would grip too close to the edge of the plate. Thus a correct fit of the clamp on the plate is not assured!)

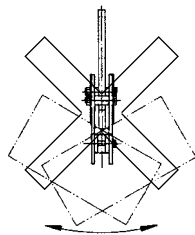

- Always insert the load fully into the mouth of the clamp and make sure that the housing has contact on either side of the plate.
- Clamps designed for the transport of steel plate in vertical position may only accept one single plate at a time. The clamping effect must be assured on either side of the load!
- Special clamps are available for the transport of steel plate in horizontal position which allows handling of several plates at a time.
- A load must not be suspended or left unattended in raised or tensioned condition for a longer period of time.
- When attaching the clamp, the operator must ensure that neither the clamp, slings or load pose a danger to himself or other personnel.
- The operator may not move the load until he is convinced that the load is correctly attached and all personnel are outside the danger zone.
- Please take note of possible capacity restrictions depending on the pivoting range resp. pulling direction of the clamp. (Note: Not all clamp types on the market are designed for a pivoting range of 180° – strictly observe the operating instructions!)
- In case of malfunction stop using the load hoisting tackle immediately.

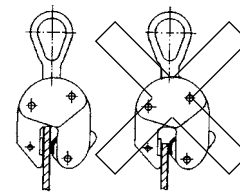

**Due to the limitations of space in this catalogue we could not respond to all applications. Please contact us for further information.**

## Maintenance and repair

- To ensure safe operation, all load hoisting tackle must be subjected to regular inspections according to the maintenance instructions given by the manufacturer.
- Load hoisting tackle which are due for maintenance (normally once per year, unless adverse working conditions dictate shorter periods) or products with obvious defects may be returned to us for inspection and repair.
- Inspections and tests must be performed by competent persons or specialist workshops that use original spare parts.

## Inspections

- Inspections are visual and functional and shall establish that the load hoisting tackle is safe and has not been damaged by incorrect transport or storage. In addition check for damage, wear, corrosion and other deficiencies as well as completeness and function of safety devices. Inspections are instigated by the user.
- All load hoisting tackle has to be cleaned prior to inspection. The cleaning procedure must not cause chemical damages (e.g. no acid – embrittlement), no incorrect temperature stress by e.g. flame cleaning or possible concealment of cracks due to excessive material loss (sand blasting)!
- We shall be pleased to consult you in this respect. Please submit your load hoisting tackle for inspection in clean condition. This will reduce inspection costs considerably.

## Criteria for disposal of load hoisting tackle

**Load hoisting tackle must no longer be operated if e.g.:**

- The identification (identity plate) is missing or illegible.
- Housing, components and suspension of the tackle present obvious deficiencies, e.g. cuts, grooves, cracks, excessive corrosion, staining due to heat, signs of subsequent welding resp. spatters (which cannot be easily removed) and leave stains.
- Ropes show breakages of wires resp. bruises (criteria for disposal of ropes are given in classification DIN 15020), damages to the rope sleeve and similar failures.
- The load chain presents twisted or distorted links or shows an elongation of 5% resp. undergoes the averaged nominal thickness of the link by more than 10%.
- The opening (C) of either suspension or load hook has increased/deformed by more than 10% of the nominal dimension or shows wear in the hook mouth (dimensions B resp. D) of more than 5%.
- If the inspection revealed that the tackle has been overloaded or deteriorated it can only be used again after careful inspection and repair – if necessary.

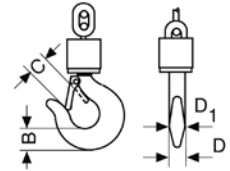

**For information on training please see page 4-5.**

Technical questionnaire for choosing the suitable Tigrip® load hoisting tackle

Company: \_\_\_\_\_ Date: \_\_\_\_\_

Contact: \_\_\_\_\_ e-Mail: \_\_\_\_\_

Phone: \_\_\_\_\_ Fax: \_\_\_\_\_

Clamps and grabs

Information about the load:

What will be transported?

Weight min. \_\_\_\_\_ kg - max. \_\_\_\_\_ kg

Length min. \_\_\_\_\_ mm - max. \_\_\_\_\_ mm

Width min. \_\_\_\_\_ mm - max. \_\_\_\_\_ mm

Height min. \_\_\_\_\_ mm - max. \_\_\_\_\_ mm

External diameter min. \_\_\_\_\_ mm - max. \_\_\_\_\_ mm

Internal diameter min. \_\_\_\_\_ mm - max. \_\_\_\_\_ mm

Material  Steel  Concrete  Wood  Paper  Others

Surface hardness for steel: \_\_\_\_\_ HRC

Surface condition  Oiled  Greasy  Dry  Scales  Others

How should/may the load be grabbed/clamped:

Grabbed from underneath  Jaws  Protective lining  Others

Information about the clamp/grab:

What kind of grab will be needed?

Type of crane hook or dimensions A - B

Model: \_\_\_\_\_ A = \_\_\_\_\_

B = \_\_\_\_\_

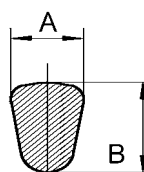

Other restrictions: \_\_\_\_\_

\_\_\_\_\_



**The min. load is 10% of the nominal WLL!**

## Plate clamp with safety lock model TBL

Capacity 500 - 3000 kg

This clamp is primarily used for transporting single steel plates in the vertical position, as well as lifting and turning through 180°. This clamp can also be used for transporting steel constructions and profiles. It is recommended to use a pair of plate clamps in conjunction with a spreader beam for large sized sheets and long materials which have a tendency to sag.

The jaw can be opened and closed with the locking lever (except for the TBL 0.5 t which uses a positive spring-loaded cam). The safety lock overrides the spring-loaded cam, preventing the clamp from opening even when there is no load.

This plate clamp is service-friendly, making it easy to exchange parts, which are available individually or in kits. Clamp repair is available by the factory, or can be done by certified and experienced staff.

The TBL 0.5 is equipped with a safety lock (positive spring-loaded cam), but comes without locking lever.

### Technical data model TBL

Model	EAN-No. 4025092*	Capacity kg	Jaw capacity Z mm	Weight kg
TBL 0,5	*550000	500	0 - 16	1.5
TBL 1,0	*550017	1000	0 - 20	3.0
TBL 2,0	*550024	2000	0 - 32	9.3
TBL 3,0	*550048	3000	0 - 32	9.3

### Dimensions model TBL

Model	TBL 0,5	TBL 1,0	TBL 2,0	TBL 3,0
A, mm	99	126	192	192
B, mm	195	225	312	312
Ø C, mm	29	50	80	80
D, mm	33	49	75	75
E, mm	47	70	96	96
F, mm	50	82	100	100
G, mm	48	55	81	81
H, mm	11	12	20	20
I, mm	16	20	24	24

**The surface hardness of the material must not exceed HRC 30/Brinell 300.**

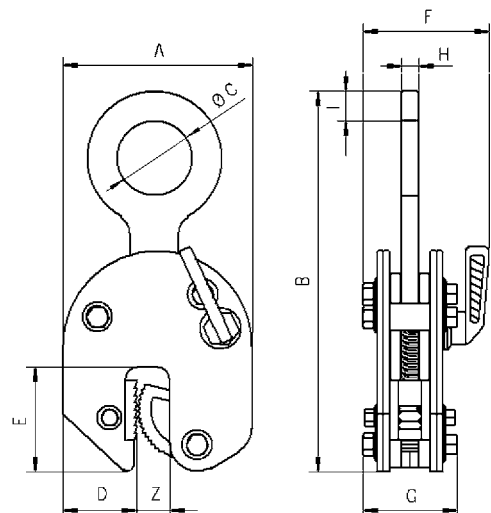

## Plate clamp with safety lock model TBL

Capacity 4000 - 30000 kg

This clamp is primarily used for transporting single steel plates in the vertical position, as well as lifting and turning through 180°. This clamp can also be used for transporting steel constructions and profiles. It is recommended to use a pair of plate clamps in conjunction with a spreader beam for large sized sheets and long materials which have a tendency to sag.

These plate clamps have the same design and applications as the clamp model TBL with a capacity from 500 - 3000 kg.



**!** The surface hardness of the material must not exceed HRC 30/Brinell 300.

### Technical data model TBL

Model	EAN-No. 4025092*	Capacity kg	Jaw capacity Z mm	Weight kg
TBL 4,0 S	*556545	4000	0 - 32	11.2
TBL 4,0 L	*556569	4000	30 - 60	11.9
TBL 6,0 S	*557221	6000	0 - 50	20.6
TBL 6,0 L	*556583	6000	50 - 100	23.2
TBL 8,0 S	*557245	8000	0 - 50	24.2
TBL 8,0 L	*557269	8000	50 - 100	28.8
TBL 10,0 S	*557283	10000	0 - 50	29.5
TBL 10,0 L	*557306	10000	50 - 100	35.1
TBL 12,0 S	*557320	12000	0 - 50	52.1
TBL 12,0 L	*557344	12000	50 - 100	63.0
TBL 15,0 S	*552936	15000	0 - 50	76.0
TBL 15,0 L	*552943	15000	50 - 100	86.0
TBL 20,0 S	*552950	20000	0 - 65	123.0
TBL 20,0 L	*551892	20000	65 - 130	135.0
TBL 30,0 S	*552967	30000	0 - 65	195.0
TBL 30,0 L	*552974	30000	65 - 130	256.0

**!** The min. load is 10% of the nominal WLL!

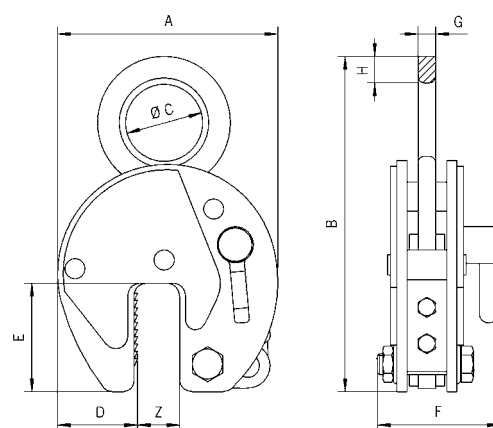

### Dimensions model TBL

Model	TBL 4,0 S	TBL 4,0 L	TBL 6,0 S	TBL 6,0 L	TBL 8,0 S	TBL 8,0 L	TBL 10,0 S	TBL 10,0 L	TBL 12,0 S	TBL 12,0 L	TBL 15,0 S	TBL 15,0 L	TBL 20,0 S	TBL 20,0 L	TBL 30,0 S	TBL 30,0 L
A, mm	197	228	293	362	293	362	293	362	360	460	360	460	462	560	462	560
B, mm	339	339	442	482	450	482	503	503	550	615	550	615	674	724	667	732
Ø C, mm	80	80	89	89	89	89	110	110	130	130	130	130	130	130	60	60
D, mm	68	68	95	114	95	114	95	114	125	175	125	175	165	195	165	195
E, mm	93	100	143	143	143	143	143	143	162	162	162	162	210	210	210	210
F, mm	110	110	129	129	129	129	139	139	154	154	204	204	235	235	295	295
G, mm	20	20	20	20	20	20	25	25	30	30	45	45	45	45	65	65
H, mm	32	32	35	35	42	42	45	45	55	55	55	55	65	65	66	67





## Plate clamp with hinged hook ring and safety lock model TBS

Capacity 1000 - 3000 kg

The TBS plate clamp with hinged hook ring can be used for the safe handling of plates at various angles. It can lift plates from the horizontal and put down in the vertical or alternatively lift it over the edge by gripping it from the side. The hinged hook ring ensures adequate clamping force in every position. Depending on the angle of usage capacity restrictions have to be taken into account, as shown in the diagram below.

The hinged hook ring has the added advantage of providing enough clamping force to hold a plate safely. Even when transporting large-sized plates with the 2-legged lifting system slipping of the load and damage to the clamp is avoided.

In addition to transporting plates, this clamp is suitable for turning steel structures and welded constructions.

**The min. load is 10% of the nominal WLL!**

**The surface hardness of the material must not exceed HRC 30/Brinell 300.**

### Technical data model TBS

Model	EAN-No. 4025092*	Capacity kg	Jaw capacity Z mm	Weight kg
TBS 1,0	*550031	1000	0 - 20	4.6
TBS 2,0	*550086	2000	0 - 32	14.3
TBS 3,0	*550079	3000	0 - 32	14.3

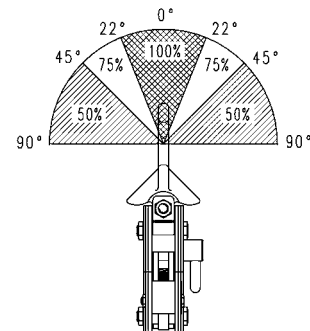

### Dimensions model TBS

Model	TBS 1,0	TBS 2,0	TBS 3,0
A, mm	126	192	192
B, mm	270	382	382
Ø C, mm	50	80	80
D, mm	49	75	75
E, mm	70	96	96
F, mm	95	132	132
G, mm	63	92	92
H, mm	12	20	20
I, mm	23	30	30

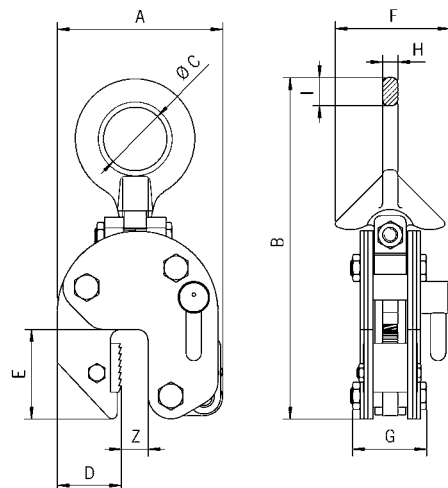
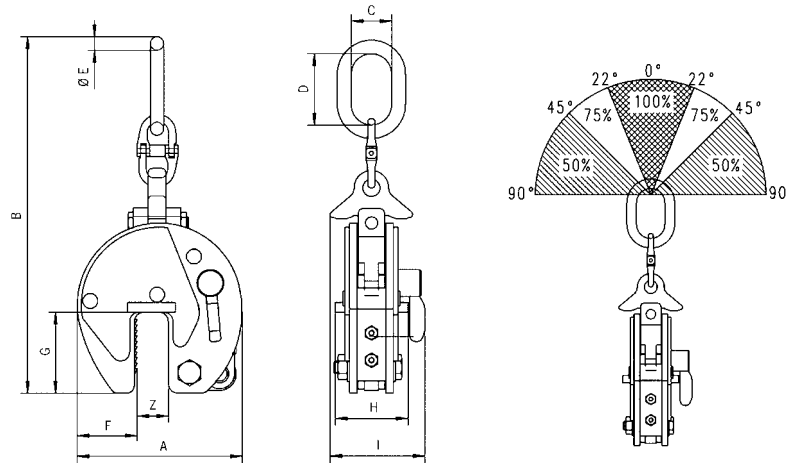

Plate clamp  
with pivoting shackle and  
safety lock  
model TBS

Capacity 4500 - 10000 kg



**The surface hardness of the material must not exceed HRC 30/Brinell 300.**



**The min. load is 10% of the nominal WLL!**

Technical data model TBS

Model	EAN-No. 4025092*	Capacity kg	Jaw capacity Z mm	Weight kg
TBS 4,5	*550352	4500	0 - 50	34.4
TBS 6,0 S	*550383	6000	0 - 50	38.0
TBS 6,0 L	*551250	6000	50 - 100	42.0
TBS 8,0 S	*552578	8000	0 - 50	39.0
TBS 8,0 L	*557528	8000	50 - 100	42.4
TBS 10,0 S	*552516	10000	0 - 50	68.0
TBS 10,0 L	*557542	10000	50 - 100	80.0

Dimensions model TBS

Model	TBS 4,5	TBS 6,0 S	TBS 6,0 L	TBS 8,0 S	TBS 8,0 L	TBS 10,0 S	TBS 10,0 L
A, mm	292	292	367	292	367	360	446
B, mm	675	737	785	737	785	903	921
C, mm	90	95	98	98	98	110	112
D, mm	180	176	180	176	180	195	195
Ø E, mm	27.8	27.8	27.8	27.8	27.8	33	33
F, mm	95	95	115	95	115	125	168
G, mm	143	143	143	143	143	162	162
H, mm	135	137	135	136	136	170	170
I, mm	185	188	188	210	210	223	223



## Plate clamp model Shark

Capacity 1000 - 3000 kg

### Features

- For the toughest operating conditions.
- This clamp is primarily used for transporting single steel plates in the vertical position, as well as lifting and turning through 180°, up to a surface hardness of HRC 40.
- Quality as yet unknown for plate clamps, guarantees highest safety standards and an extremely long service life.
- Fulfils the requirements of all relevant standards and EU-Directives.

### Options

- Special jaws for a surface hardness up to HRC 50. Especially for alloyed / stainless steel and slippery surfaces.

**The surface hardness of the material must not exceed HRC 40.**

**The min. load is 10% of the nominal WLL!**

### Technical data model Shark

Model	EAN-No. 4025092*	Capacity kg	Jaw capacity Z mm	Weight kg
Shark 1,0	*558808	1000	0 - 20	3.3
Shark 2,0	*558815	2000	0 - 32	6.8
Shark 3,0	*198110	3000	0 - 32	7.2

### Dimensions model Shark

Model	Shark 1,0	Shark 2,0	Shark 3,0
A, mm	120	170	170
B, mm	240	345	362
Ø C, mm	36	65	80
D, mm	42	58	58
E, mm	60	80	80
F, mm	72	88	88
G, mm	58	69	69
H, mm	12	15	15
I, mm	12	19	20
J, mm	137	191	191
K, mm	152	214	214
L, mm	210	302	320

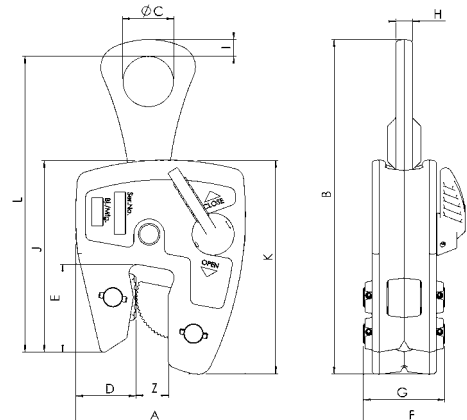

Embossed marking for unambiguous identification

Smooth mechanical operation, tight tolerances, mechanically optimized, precise workmanship

Easy maintenance, simple and fast replacement of wear parts

Reinforcement on the lifting eye prevents it from twisting, during unintentional side / lateral pull

Higher clamping forces. Optimized clamping forces in every position

Heavy duty housing, drop forged, absolutely twist free

Pivoting jaw guarantees that the full surface of the jaw makes contact with the plate surface, ensuring the safe turning of sheet metal and steel plates

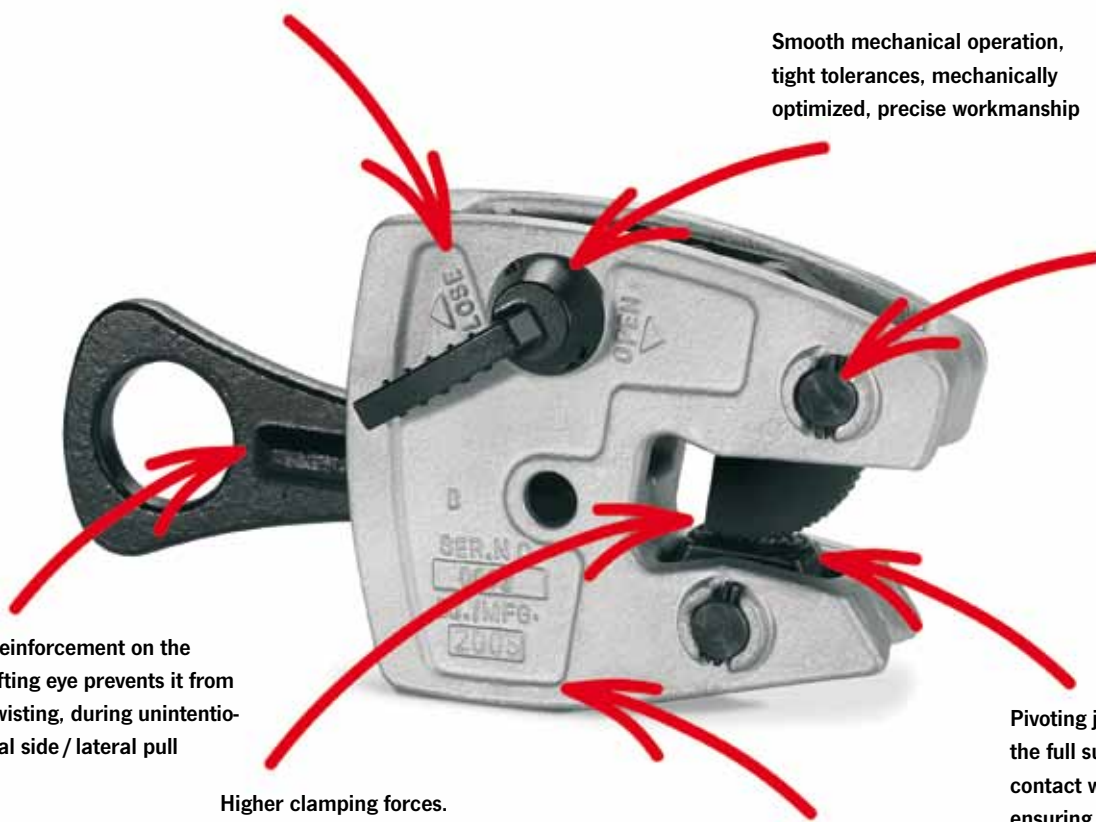

*Patent pending for special jaws!*



Special jaw



## Plate clamp with hinged hook ring model Shark-S

Capacity 1000 - 3000 kg

### Features

- For the toughest operating conditions.
- This clamp is primarily used for transporting single steel plates in the vertical position, as well as lifting and turning through 180°, up to a surface hardness of HRC 40.
- With hinged hook ring to be used as a two-legged lifting system (see diagram of forces).
- Quality as yet unknown for plate clamps, guarantees highest safety standards and an extremely long service life.
- Fulfils the requirements of all relevant standards and EU-Directives.

### Options

- Special jaws for a surface hardness up to HRC 50. Especially for alloyed / stainless steel and slippery surfaces.

**The min. load is 10% of the nominal WLL!**

**The surface hardness of the material must not exceed HRC 40.**

### Technical data model Shark-S

Model	EAN-No. 4025092*	Capacity kg	Jaw capacity Z mm	Weight kg
Shark-S 1,0	*558822	1000	0 - 20	3.6
Shark-S 2,0	*558839	2000	0 - 32	7.8
Shark-S 3,0	*197984	3000	0 - 32	8.3

### Dimensions model Shark-S

Model	Shark-S 1,0	Shark-S 2,0	Shark-S 3,0
A, mm	120	170	170
B, mm	248	349	378
Ø C, mm	38	65	80
D, mm	42	58	58
E, mm	60	80	80
F, mm	72	88	88
G, mm	58	69	69
H, mm	12	19	19
I, mm	13	20	20
J, mm	137	191	191
K, mm	152	214	214
L, mm	223	326	336

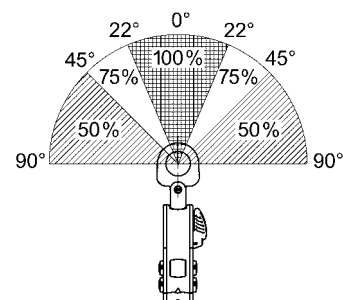
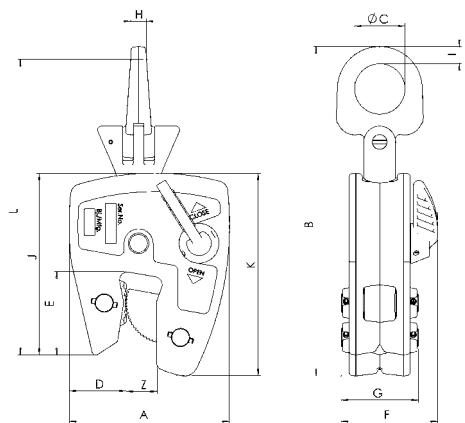

Embossed marking for unambiguous identification

Smooth mechanical operation, tight tolerances, mechanically optimized, precise workmanship

Easy maintenance, simple and fast replacement of wear parts

Hinged hook ring

Higher clamping forces. Optimized clamping forces in every position

Heavy duty housing, drop forged, absolutely twist free

Pivoting jaw guarantees that the full surface of the jaw makes contact with the plate surface, ensuring the safe turning of sheet metal and steel plates

*Patent pending for special jaws!*



Special jaw





## Universal grab model TAG

Capacity 350 - 10000 kg

The universal grab TAG saves time, as it does not require chains, cables etc. when hoisting and loading material. The large jaw capacity allows to tackle a variety of sizes with only one clamp. It can be used for loading machine tools, lifting steel constructions, welding and assembly jobs as well as for concrete and prefabricated pieces.

### Features

- The automatic clamping force is retained by a positive tension spring, even if there is slack in the chain.
- The "Quick-Open" type universal grab opens by lifting and simultaneously pulling the lever out against the tension spring. The jaw is closed by the spring.
- Universal grabs up to 2.0 t capacity are equipped with round chains, clamps with increased capacities are delivered with roller chains.

### Options

- Grabs up to 1.25 t WLL are available with a protective lining on the clamping jaws on request. This results in a decrease of the jaw capacity by 10 mm.



**!** The surface hardness of the material must not exceed HRC 30/Brinell 300.



Special version of universal grab model TAG with modified side plates for use in confined spaces.

Technical data model TAG

Model	EAN-No. 4025092*	Capacity kg	Jaw width mm	Jaw capacity mm	Weight kg
TAG 0,35/100	*550413	350	100	0 - 100	8.7
TAG 0,35/200	*551724	350	200	90 - 200	16.3
TAG 0,75/100	*550253	750	100	0 - 100	8.6
TAG 0,75/200	*552806	750	200	90 - 200	16.6
TAG 1,25/100	*550468	1250	100	0 - 100	14.9
TAG 1,25/200	*551502	1250	200	90 - 200	24.3
TAG 2,0/100	*550642	2000	100	0 - 100	20.8
TAG 2,0/200	*551366	2000	200	90 - 200	29.1
TAG 3,0/90	*550840	3000	90	5 - 90	26.5
TAG 5,0/90	*550345	5000	90	5 - 90	30.5
TAG 5,0/170	*551915	5000	170	80 - 170	43.8
TAG 10,0/100	*552059	10000	100	0 - 100	70.0
TAG 10,0/200	*553001	10000	200	100 - 200	105.0

Dimensions model TAG

Model	TAG 0,35/100	TAG 0,35/200	TAG 0,75/100	TAG 0,75/200	TAG 1,25/100	TAG 1,25/200	TAG 2,0/100	TAG 2,0/200	TAG 3,0/90	TAG 5,0/90	TAG 5,0/170	TAG 10,0/100	TAG 10,0/200
A, mm	264	382	264	382	320	382	328	375	297	297	354	405	440
B, mm	259	434	259	434	289	434	415	515	290	290	423	423	562
C, mm	128	195	128	195	128	195	135	195	136	136	180	160	200
D, mm	100	156	100	156	100	156	115	165	106	106	155	130	175
E, mm	100	200	100	200	100	200	100	200	90	90	170	100	200
F, mm	85	120	85	120	85	120	105	160	91	91	118	160	183
G, mm	550	760	550	760	570	760	571	750	570	570	620	720	840
H, mm	75	75	75	75	75	75	75	75	82	82	82	102	102
I, mm	121	121	121	121	121	121	121	121	111	111	111	144	144
J, mm	20	20	20	20	20	20	20	20	32	32	32	40	40
K, mm	78	90	83	90	83	90	105	105	137	147	147	208	208

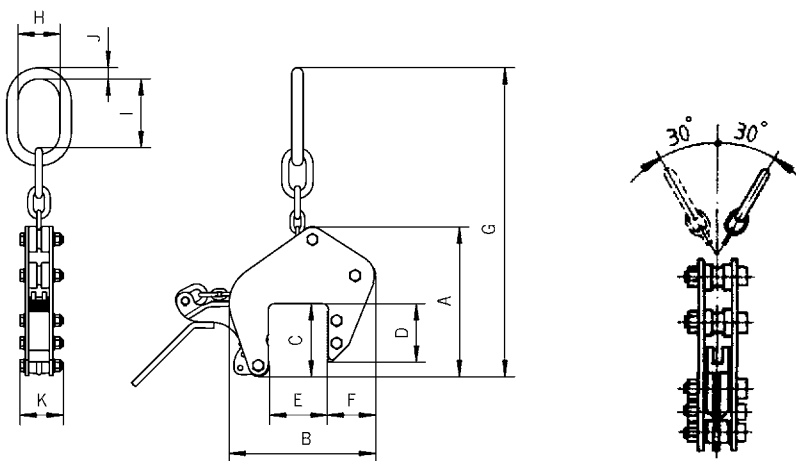

Only for model TAG up to 2.0 t

**The min. load is 10% of the nominal WLL!**

## Permanent load lifting magnets model TPM

### Capacity

100 - 2000 kg (Flat material),  
50 - 1000 kg (Round material)

TPM load lifting magnets are ideal tools for easy, quick and thus economical transport of heavy objects made of ferro-magnetic material. Typical operating areas are workshops and warehouses, loading and unloading of machines as well as construction of jigs and fixtures.

Compact design of the units for a large number of applications.

The load is not affected mechanically which allows lifting of flat as well as round material. The efficient magnet body provides strong lifting capacity at low dead weight. The permanent magnets do not require electric energy and will leave only minor residual magnetism on the material after use.

The magnets are activated / deactivated easily by turning a locking lever. In activated condition the hand lever will be safely locked and thus prevent unintended demagnetising.

The selection of the appropriate magnet model should be made under consideration of the varying conditions of the contact surface, kind of material alloy and plate thickness / bar diameter (see table).

**In order to achieve a maximum capacity, the contact surface should be bright and free from dirt, oil, grease, scale, corrosion, paint etc.**



## Technical data model TPM

Model	EAN-No. 4025092*	Flat material capacity** max. kg	Material thickness min. at max. capacity mm	Flat material length of material max. mm	Round material capacity** max. kg	Round material diameter mm	Round material length of material max. mm	Test load kg	Weight kg
TPM 0,1	*558853	100	14	2000	50	200 - 300	2000	300	6.8
TPM 0,3	*558860	300	20	2500	150	200 - 300	2500	900	15.5
TPM 0,5	*558877	500	24	3000	250	200 - 400	3000	1500	30.6
TPM 0,8	*558884	800	34	3500	400	200 - 400	3500	2400	56.0
TPM 1,0	*558891	1000	40	3500	500	200 - 400	3500	3000	61.0
TPM 2,0	*190367	2000	55	3500	1000	200 - 400	3500	6000	126.0

\*\*measured on mild steel St 37

## Dimensions model TPM

Model	TPM 0,1	TPM 0,3	TPM 0,5	TPM 0,8	TPM 1,0	TPM 2,0
A, mm	122	192	232	302	332	392
B, mm	69	95	120	154	154	196
C, mm	185	225	270	320	320	420
D, mm	160	250	250	450	450	450

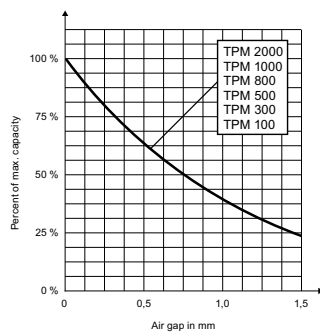

Diagram: WLL/air gap

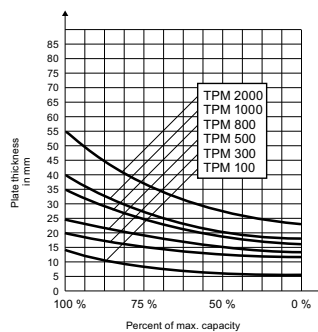
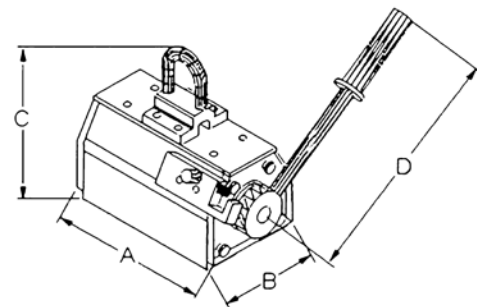
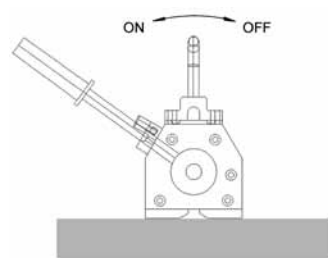

Diagram: WLL/material thickness



Model TPM



Correct use On/Off

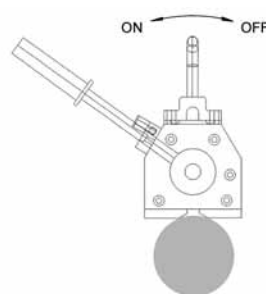

Reduction of capacity	% of capacity
Temperature ≤ 60° C	100 %
Humidity ≤ 80 %	100 %
St 52	95 %
Alloy steel	80 %
High carbon steel	70 %
Cast iron	45 %
Nickel	45 %
Austenitic, stainless steel	0 %
Brass	0 %
Aluminium	0 %





## Non-marring grab model TBP

Capacity 500 - 1500 kg

The TBP non-marring grab is suitable for lifting, turning and transporting of plates with a sensitive surface without leaving behind indentations.

It can be used for aluminium and stainless steel plate or those with an extremely hard surface.

**!** The surface of the plate must be free of oil, grease or any other liquid to ensure safe transport.

### Technical data model TBP

Model	EAN-No. 4025092*	Capacity kg	Jaw capacity Z mm	Weight kg
TBP 0,5	*556378	500	0 - 10	3.0
TBP 1,5	*556392	1500	0 - 20	12.6

### Dimensions model TBP

Model	TBP 0,5	TBP 1,5
A, mm	127	215
B, mm	200	345
D, mm	52	75
E, mm	69	135
F, mm	87	131
G, mm	76	118
H, mm	13	20
I, mm	20	24
Ø C, mm	55	85

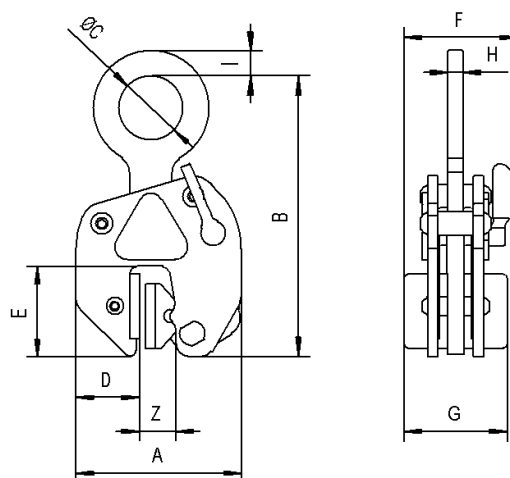

**!** The min. load is 10% of the nominal WLL!

## Non-marring grab with chain model TSB

Capacity 350 - 1250 kg

The TSB grab has parallel-facing jaws that equally distribute the clamping pressure over a relatively large surface area. This makes the grab attractive for plate material with sensitive surfaces. The protective lining "Bremsit" offers an outstanding friction coefficient, thereby enhancing the grip of the jaws. This lining can be easily replaced when worn.

Similar to the universal grab, this grab has a large jaw capacity and the security of a safety lock device with a hold-open/hold-closed feature.



**The surface of the plate must be free of oil, grease or any other liquid to ensure safe transport.**

### Technical data model TSB

Model	EAN-No. 4025092*	Capacity kg	Jaw capacity Z mm	Weight kg
TSB 0,35/65	*550772	350	0 - 65	11.6
TSB 0,75/65	*550826	750	0 - 65	11.8
TSB 1,25/65	*550727	1250	0 - 65	16.7

### Dimensions model TSB

Model	TSB 0,35/65	TSB 0,75/65	TSB 1,25/65
A, mm	270	270	270
B, mm	260	260	260
C, mm	128	128	128
D, mm	100	100	100
E, mm	65	65	65
F, mm	78	78	78

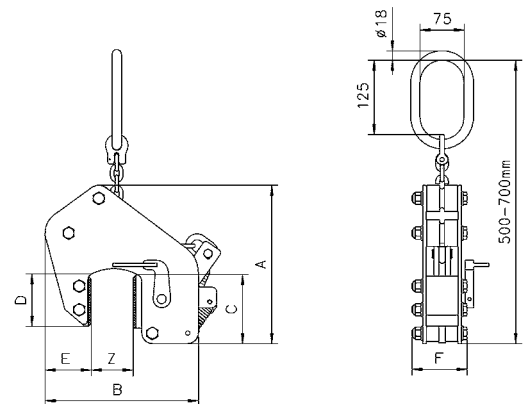

**The min. load is 10% of the nominal WLL!**







## Girder grab for horizontal transport model TTG

Capacity 500 - 7500 kg

The girder grab TTG is designed for the horizontal transport of girders, metal plates, profiles etc. The offset suspension lug ensures that the flange of the girder will be kept practically horizontal during transport.

The positive safety lock keeps the clamp safely locked, even before the lift begins. This allows the operator to place the clamp, lock it closed and move away from the load. The lever ensures easy opening and closing of the clamping jaw and has a "lock open" feature.

**When transporting long girders, it is recommended to use a pair of clamps in conjunction with a spreader beam.**

### Technical data model TTG

Model	EAN-No. 4025092*	Capacity kg	Jaw capacity mm	Weight kg
TTG 0,5	*557931	500	0 - 20	2.9
TTG 1,5	*550239	1500	0 - 30	6.8
TTG 3,0	*550192	3000	0 - 35	11.3
TTG 4,5	*550451	4500	0 - 40	14.8
TTG 7,5	*551205	7500	0 - 45	30.0

### Dimensions model TTG

Model	TTG 0,5	TTG 1,5	TTG 3,0	TTG 4,5	TTG 7,5
Ø A, mm	50	70	80	90	110
B, mm	36	43	55	60	64
C, mm	25	35	42	46	55
D, mm	148	140	180	196	222
E, mm	200	180	214	248	304
F, mm	27	40	40	40	50
G, mm	20	30	32	35	42
H, mm	95	155	190	207	237
I, mm	110	230	284	314	367
J, mm	10	15	20	20	22
K, mm	56	50	60	64	90
L, mm	85	100	114	117	143
M, mm	13	16	20	25	30

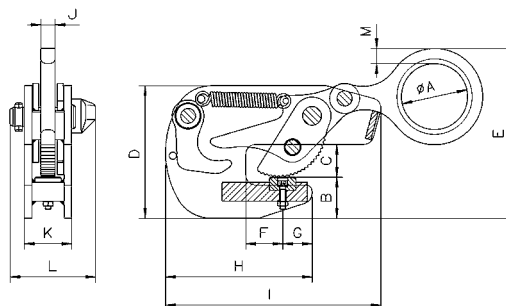

## Girder grab for vertical transport model TTR

Capacity 750 - 3000 kg

The girder grab TTR is designed for vertical transport, especially for lifting and stacking of girders. The unique position of the offset suspension lug keeps the girder virtually in a vertical position during transport.

The positive safety lock keeps the clamp safely locked, even before the lift begins. This allows the operator to place the clamp, lock it closed and move away from the load. The lever ensures easy opening and closing of the clamping jaw and has a "lock open" feature.



**!** When transporting long girders, it is recommended to use a pair of clamps in conjunction with a spreader beam.

### Technical data model TTR

Model	EAN-No. 4025092*	Capacity kg	Jaw capacity mm	Weight kg
TTR 0,75	*550499	750	5 - 16	3.1
TTR 1,50	*550246	1500	5 - 25	6.8
TTR 3,00	*550550	3000	5 - 28	10.9

### Dimensions model TTR

Model	TTR 0,75	TTR 1,50	TTR 3,00
A, mm	24	33	37
B, mm	40	53	56
C, mm	132	176	194
D, mm	62	76	78
E, mm	145	190	208
F, mm	118	152	163
Ø G, mm	50	70	80
H, mm	12	15	20
I, mm	12	17	23
K, mm	53	69	85

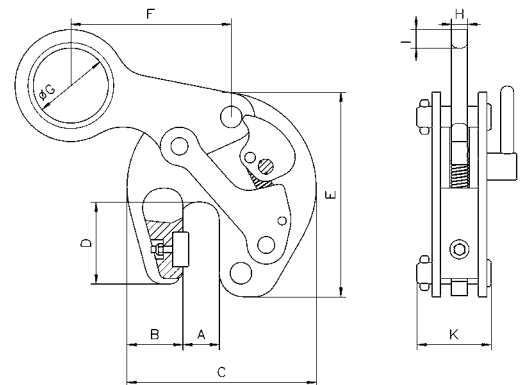



## Girder grab for horizontal transport model TTT

Capacity 750 - 4500 kg

The girder grab TTT is used for the horizontal transport of steel girders. Due to the split fixed jaw, it can be positioned centrally on the end of the beam.

The grab should only be used in pairs.

The safety lock with positive spring tension holds the grab in position on the end of the girder even without load tension.

The lever is used to engage and disengage the jaw and to keep it open.

**The angle from the vertical must not exceed 30°!**

### Technical data model TTT

Model	EAN-No. 4025092*	Capacity kg	Jaw capacity mm	Weight kg
TTT 0,75	*558501	750	0 - 20	3
TTT 1,5	*558518	1500	0 - 35	6
TTT 3,0	*558525	3000	0 - 40	10
TTT 4,5	*558532	4500	0 - 45	16

### Dimensions model TTT

Model	TTT 0,75	TTT 1,5	TTT 3,0	TTT 4,5
A, mm	30	38	50	60
B, mm	70	70	75	90
C, mm	100	155	195	222
D, mm	142	150	195	222
Ø E, mm	50	70	80	90
F, mm	16	19	19	22
G, mm	16	20	25	30
H, mm	225	335	400	450
I, mm	45	45	80	90
J, mm	200	210	214	248
K, mm	106	120	125	147
L, mm	52	66	80	88

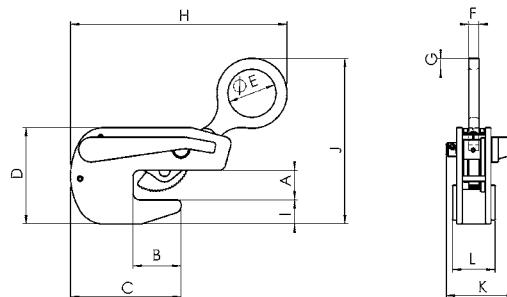

## Horizontal lifting gear model TCH

Capacity 1000 - 10000 kg

The TCH horizontal lifting gear consists of two clamps with a two-legged chain sling. It is especially suited for the transport of single plates with a minimum thickness of approx. 5 mm as well as for plate bundles.

The two-legged version is appropriate for normal sized plates. For extra large or long plates, it is recommended to use two sets of the two-legged lifting gears in conjunction with a spreader beam.

In the standard version, the lifting clamp is suitable for plates up to 1500 mm width. Lifting gears with longer chains for larger plate widths are available on request. The capacity applies to a pair of lifting clamps. Single clamps are also available.



**The angle from the vertical must not exceed 45°!**

### Technical data model TCH

Model	EAN-No. 4025092* for lifting gear two-legged	EAN-No. 4025092* single clamp	Capacity* kg	Jaw capacity mm	Weight** kg
TCH 1,0	*551625	*551212	1000	0 - 50	13.0
TCH 2,0	*551991	*551168	2000	5 - 32	17.7
TCH 4,0	*551755	*550895	4000	5 - 50	31.0
TCH 6,0	*553230	*550888	6000	5 - 75	69.0
TCH 8,0	*553247	*552097	8000	5 - 75	72.0
TCH 10,0/1	*553254	*551465	10000	5 - 100	93.8
TCH 10,0/2	*552042	*552738	10000	50 - 150	108.6

\*Per pair, up to an angle of 45° from the vertical

\*\*Weight for two single clamps with chain

### Dimensions model TCH

Model	TCH 1,0	TCH 2,0	TCH 4,0	TCH 6,0	TCH 8,0	TCH 10,0/1	TCH 10,0/2
A, mm	135	160	180	200	260	300	300
B, mm	75	90	100	110	140	160	160
Ø C, mm	18	22	26	32	36	40	40
D, mm	15	32	44	58	56	70	66
E, mm	82	83	114	172	170	216	218
F, mm	65	61	75	97	100	116	116
G, mm	100	100	99	129	128	149	150
H, mm	32	49	62	90	90	113	113
I, mm	44	72	89	127	130	113	113
Ø J, mm	13	19	26	36	37	50	50

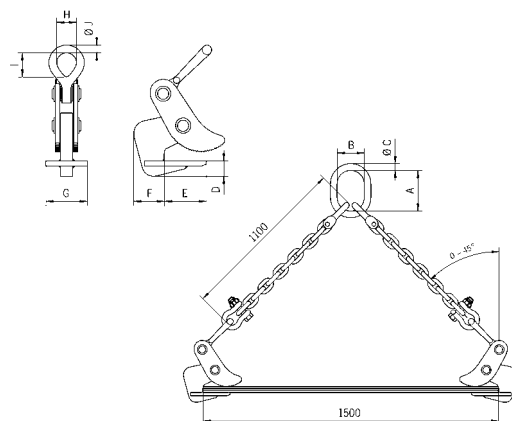



## Horizontal lifting gear model TGF

Capacity 350 - 6650 kg

The TGF horizontal lifting gear consists of two clamps with a two-legged chain sling and is especially suited for the transport of plate bundles.

For the transport of stainless steel plate bundles, plywood bundles, etc. the clamps are optionally available with flat jaws and protective lining. The clamps are easily adjusted to the height of the plate by a special ratcheting lever.

The lifting clamps are available in special versions for bundle thicknesses up to 400 mm.

### Scope of delivery for horizontal lifting gear

2 clamps and two-legged chain sling for plate width 1500 mm.

Capacity ratings are valid for a complete two-legged chain system.  
Also available as single clamp (without shackle).

### Technical data model TGF

Model	EAN-No. 4025092* for lifting gear two-legged	EAN-No. 4025092* single clamp	Capacity* kg	Jaw capacity Z mm	Weight** kg
TGF 0,3/150	*553087	*553216	350	0 - 150	21
TGF 0,6/150	*553094	*553223	650	0 - 150	22
TGF 1,3/150	*552745	*552554	1300	0 - 150	23
TGF 2,3/150	*551731	*551809	2300	0 - 150	33
TGF 3,3/150	*551342	*550833	3300	0 - 150	39
TGF 5,0/150	*553100	*553322	5000	0 - 150	59
TGF 6,6/150	*553117	*551885	6650	0 - 150	65
TGF 0,3/250	*552882	*553339	350	0 - 250	21
TGF 0,6/250	*553124	*552387	650	0 - 250	22
TGF 1,3/250	*552608	*553346	1300	0 - 250	23
TGF 2,3/250	*552363	*552622	2300	0 - 250	33
TGF 3,3/250	*553131	*551540	3300	0 - 250	39
TGF 5,0/250	*552189	*553353	5000	0 - 250	59
TGF 6,6/250	*553148	*551656	6650	0 - 250	87

\*Complete two-legged lifting gear, angle from the vertical max. 45°

\*\*Complete two-legged lifting gear

The angle from the vertical must not exceed 45°!

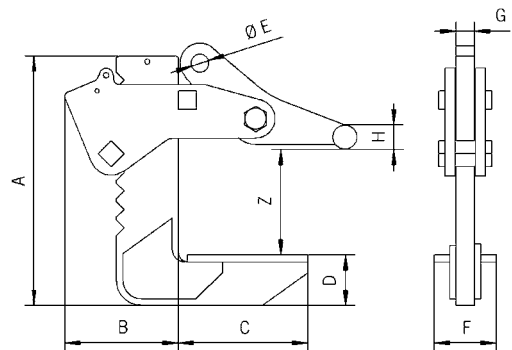

### Dimensions model TGF

Model	TGF 0,3/150	TGF 0,6/150	TGF 1,3/150	TGF 2,3/150	TGF 3,3/150	TGF 5,0/150	TGF 6,6/150	TGF 0,3/250	TGF 0,6/250	TGF 1,3/250	TGF 2,3/250	TGF 3,3/250	TGF 5,0/250	TGF 6,6/250
A, mm	298	298	298	321	321	405	405	448	448	448	417	417	495	495
B, mm	122	122	122	130	130	185	185	122	122	122	130	130	185	185
C, mm	160	160	160	160	160	210	210	140	140	140	160	160	210	210
D, mm	41	41	41	50	50	82	82	41	41	41	60	60	82	82
Ø E, mm	20	20	20	23	23	30	30	20	20	20	23	23	30	30
F, mm	80	80	80	80	80	100	100	80	80	80	80	80	100	100
G, mm	20	20	20	25	25	30	30	20	20	20	25	25	30	30
Ø H, mm	25	25	25	25	25	40	40	25	25	25	25	25	40	40

## Horizontal lifting hook model BVH

Capacity 500 - 7500 kg

The BVH horizontal lifting hooks are used in pairs with chain or wire rope slings to lift plate bundles that are relatively close to the ground.

The high tensile hooks have a serrated lifting surface.



- ! The angle from the vertical must be 30-45°.
- The chain has to be in line with the crank of the lifting hooks.

### Technical data model BVH

Model	EAN-No. 4025092*	Capacity* kg	Weight kg
BVH 0,5	*557023	500	1.2
BVH 1,12	*557047	1120	1.4
BVH 1,5	*557061	1500	2.4
BVH 2,0	*557085	2000	3.9
BVH 2,5	*557108	2500	8.2
BVH 3,2	*557122	3200	8.3
BVH 4,0	*557146	4000	13.6
BVH 5,0	*557160	5000	21.0
BVH 6,0	*557184	6000	39.0
BVH 7,5	*557207	7500	60.0

\*Per unit

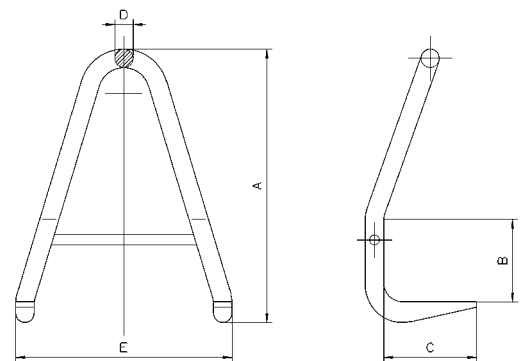

### Dimensions model BVH

Model	BVH 0,5	BVH 1,12	BVH 1,5	BVH 2,0	BVH 2,5	BVH 3,2	BVH 4,0	BVH 5,0	BVH 6,0	BVH 7,5
A, mm	180	210	240	280	340	400	530	660	800	980
B, mm	50	60	70	80	100	120	160	200	250	300
C, mm	80	95	105	115	120	140	180	210	250	300
D, mm	18	20	22	26	32	32	36	40	50	60
E, mm	150	170	200	220	270	320	420	520	640	760





## Lifting clamp with safety lock model THS

Capacity 750 - 4500 kg

The THS lifting clamp is normally used in pairs especially for the horizontal transport of plates. The transport of slightly sagging plates is also possible. Individually, it can be used to load presses shears, and other machines. The safety lock is preventing the clamp from opening, even when there is no load. The jaws can be opened and closed with the safety lock lever. This clamp has a lock-open feature.

### Options

- The models THS 1.5 and THS 3.0 are available with a hinged hook ring on request.

**When used in pairs the angle from the vertical must not exceed 30°!**



### Technical data model THS

Model	EAN-No. 4025092*	Capacity* kg	Jaw capacity mm	Weight kg
THS 0,75	*551267	750	0 - 20	3.2
THS 1,5	*550734	1500	0 - 35	6.1
THS 3,0	*551373	3000	0 - 40	12.7
THS 4,5	*553483	4500	0 - 40	16.5

\*Per unit

### Dimensions model THS

Model	THS 0,75	THS 1,5	THS 3,0	THS 4,5
A, mm	30	38	45	47
B, mm	70	80	95	110
C, mm	130	165	205	235
D, mm	97	120	160	196
Ø E, mm	50	70	80	90
F, mm	12	15	20	20
G, mm	15	17	25	30
H, mm	255	335	400	450
I, mm	15	20	30	59
J, mm	135	165	195	230
K, mm	80	90	100	110
L, mm	40	50	60	64

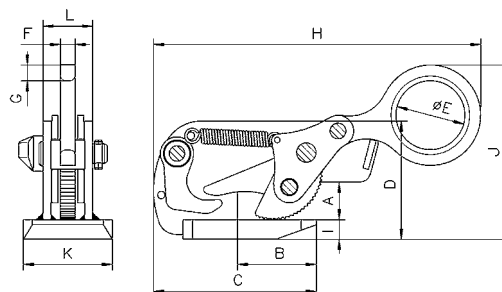

## Lifting clamp model TWH

Capacity 1500 - 5000 kg

The TWH lifting clamp, when used in pairs, is well-suited for horizontal transport of individual and bundled plates. The clamp is not suited for thin plates that have a tendency to sag during transport.

It is normally used in combination with a two-legged chain sling.

The capacity (WLL) applies to a pair of lifting clamps.

### Options

- Protective lining



**The angle from the vertical must not exceed 45°.**

### Technical data model TWH

Model	EAN-No. 4025092*	Capacity* kg	Jaw capacity mm	Weight** kg
TWH 30 with rollers	*550529	1500	5 - 60	5.6
TWH 50 with rollers	*551441	2500	10 - 70	10.3
TWH 70 with rollers	*551380	3500	10 - 80	13.4
TWH 100 with rollers	*551618	5000	10 - 102	27.7
TWH 30 with plate	*555654	1500	5 - 60	5.7
TWH 50 with plate	*555661	2500	10 - 70	10.3
TWH 70 with plate	*555678	3500	10 - 80	13.5
TWH 100 with plate	*555685	5000	10 - 102	27.8

\*Per pair, angle from the vertical max. 45°

\*\*Per unit

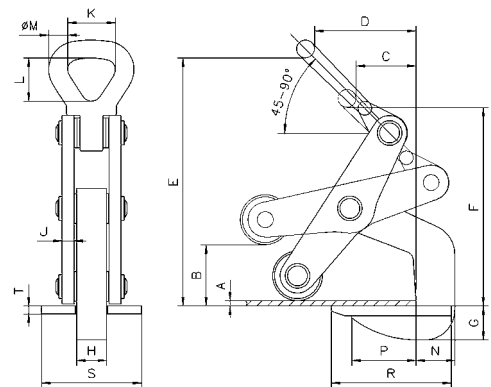

Model TWH with rollers

### Dimensions model TWH

Model	TWH 30 with rollers	TWH 50 with rollers	TWH 70 with rollers	TWH 100 with rollers	TWH 30 with plate	TWH 50 with plate	TWH 70 with plate	TWH 100 with plate
A, mm	5	10	10	10	5	10	10	10
B, mm	60	70	80	102	60	70	80	102
C, mm	60	75	90	110	60	75	90	110
D, mm	105	130	162	170	105	130	162	170
E, mm	250	315	345	425	250	315	345	425
F, mm	200	275	292	345	200	275	292	345
G, mm	31	45	55	57	22	38	48	45
H, mm	30	30	30	45	30	30	30	45
J, mm	12	12	15	20	12	12	15	20
K, mm	50	64	64	89	50	64	64	89
L, mm	73	92	92	130	73	92	92	130
Ø M, mm	18	25	25	35	18	25	25	35
N, mm	36	58	65	80	36	58	65	80
P, mm	65	77	105	120	65	77	105	120
R, mm	120	150	185	210	120	150	185	210
S, mm	100	100	100	120	100	100	100	120
T, mm	10	10	10	12	10	10	10	12

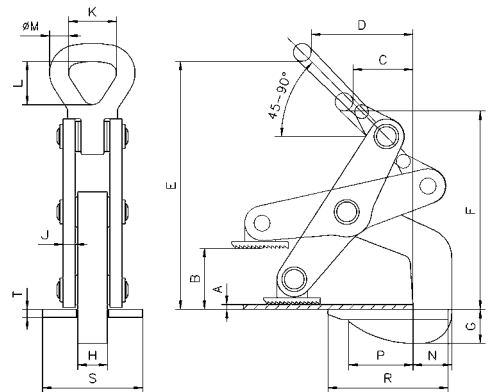

Model TWH with plate



## Lifting clamp model THK

Capacity 750 - 9000 kg

The THK lifting clamp, when used in pairs, is especially well-suited for horizontal transport of thin plates that have a tendency to sag.

It is normally used in combination with a two-legged chain sling.

The capacity applies to a pair of lifting clamps.



**!** The angle from the vertical must not exceed 30°!

### Technical data model THK

Model	EAN-No. 4025092*	Capacity* kg	Jaw capacity mm	Weight** kg
THK 0,75	*550628	750	0 - 25	1.7
THK 1,5	*550284	1500	0 - 35	3.2
THK 3,0	*550390	3000	0 - 35	5.7
THK 4,5	*551120	4500	0 - 45	8.4
THK 6,0	*551038	6000	0 - 60	11.6
THK 9,0	*551960	9000	0 - 60	17.9

\*Per pair, angle up to 30° from the vertical

\*\*Per unit

### Dimensions model THK

Model	THK 0,75	THK 1,5	THK 3,0	THK 4,5	THK 6,0	THK 9,0
A, mm	25	36	38	48	63	65
B, mm	72	80	93	103	124	113
C, mm	118	135	168	183	214	223
D, mm	81	102	119	140	176	188
Ø E, mm	20	25	30	30	35	40
F, mm	161	198	227	238	284	317
G, mm	12	15	20	25	30	35
H, mm	86	102	110	122	110	148
I, mm	12	15	20	20	20	20

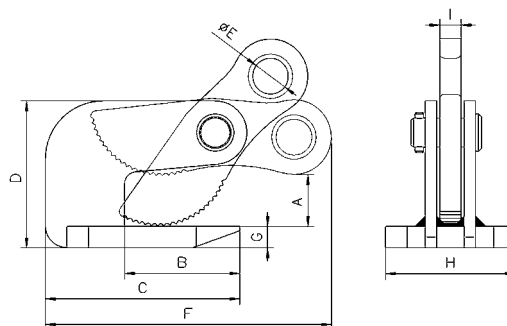

### Board clamp model TPZ

Capacity 400 - 750 kg

The TPZ clamp is made for lifting and vertically transporting wood, particle board and plastic sheets.

The pliers are fastened to the plate with the aid of a hand-held lever. The jaw, which has a protective lining, grabs once lifting begins and holds the board securely.



#### Technical data model TPZ

Model	EAN-No. 4025092*	Capacity kg	Jaw capacity Z mm	Weight kg
TPZ 0,4/55	*555234	400	5 - 55	6.3
TPZ 0,4/100	*558983	400	55 - 100	9.0
TPZ 0,75/60	*558990	750	5 - 60	12.0
TPZ 0,75/120	*559003	750	60 - 120	14.0

#### Dimensions model TPZ

Model	TPZ 0,4/55	TPZ 0,4/100	TPZ 0,75/60	TPZ 0,75/120
A, mm	120	120	155	155
B, mm	290	335	349	406
C, mm	525	525	545	560
D, mm	125	125	145	145
E, mm	117	117	135	135
F, mm	60	60	121	121
G, mm	40	40	75	75
H, mm	6	6	8x24	8x24

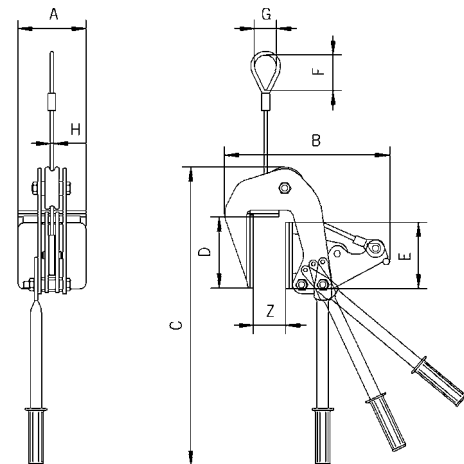

Model TPZ, up to 400 kg equipped with rope, from 750 kg equipped with chain.



## Manual claw, magnetic model THM

Capacity 120 - 170 kg

The THM manual magnetic claw is used for transporting steel sheets horizontally and vertically, lifting plates from racks, pulling steel sheets out of shelving, as well as transporting flat pieces of magnetizable steel.

The clamp, depending on the type, can be used for plate thicknesses from 1 to 5 mm.

Pressing down on the handle activates a cam which releases the magnetic claw from the workpiece.

This manual claw is maintenance-free and keeps the magnetic force for an unlimited period of time.

**In order to achieve a maximum capacity, the contact surface should be bright and free from dirt, oil, grease, scale, corrosion, paint etc.**

### Technical data model THM

Model	EAN-No. 4025092*	Capacity* kg	Pulling capacity* kg	Weight kg
THM 120	*550963	120	70	2
THM 170	*550437	170	100	2

\*Measured at a safety factor 2:1 on bright drawn material St 37 k

### Dimensions model THM

Model	THM 120	THM 170
A, mm	84	116
B, mm	140	140
C, mm	130	130
D, mm	25	25
E, mm	172	172

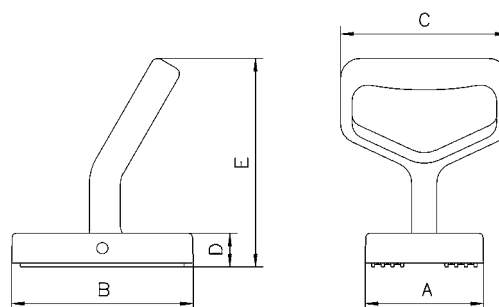

## Hand clamp model THG

### Capacity 250 kg

The THG hand clamp is suited for the individual transport of light and thin plates. Pressing down on the hand grip releases the tension spring, allowing the clamp to open and slide onto the plate.

The plate can be transported by holding onto the ergonomically designed hand grip.

The positive spring pressure prevents the plate from accidental slipping out of the clamp.



**!** The plate surface of the material must not exceed a hardness of HRC 30.

### Technical data model THG

Model	EAN-No. 4025092*	Capacity kg	Jaw capacity mm	Weight kg
THG	*556057	250	0 - 10	1.4

### Dimensions model THG

Model	THG
A, mm	184
B, mm	105
C, mm	12
D, mm	53
Thickness, mm	40

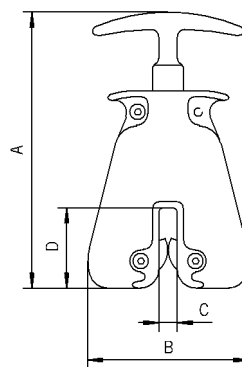

Attaching



Transport





## Screw clamp for vertical and horizontal pulling model TSH

Capacity 750 - 5000 kg

The screw clamp offers many possible applications. It is particularly useful for lifting, turning and pulling steel plates, girders and steel constructions.

The spindle is closed only finger tight.

Once the screw clamp is tightened and lifting begins, the pivoting pad clamping system produces a wedging action against the material, holding it securely.

### Technical data model TSH

Model	EAN-No. 4025092*	Capacity kg	Jaw capacity Z mm	Weight kg
TSH 0,75	*559027	750	0 - 28	3.1
TSH 1,5	*550123	1500	0 - 32	7.4
TSH 2,0	*120302	2000	90 - 140	14.8
TSH 3,0	*550154	3000	0 - 50	11.4
TSH 5,0	*550215	5000	0 - 80	27.6

### Dimensions model TSH

Model	TSH 0,75	TSH 1,5	TSH 2,0	TSH 3,0	TSH 5,0
A, mm	190	255	318	290	470
B, mm	52	65	74	74	130
Ø C, mm	19	26	30	30	50
D, mm	43	75	90	85	135
E, mm	113	130	286	170	225
F, mm	35	44	60	50	72
X, mm	15	40	38	40	50

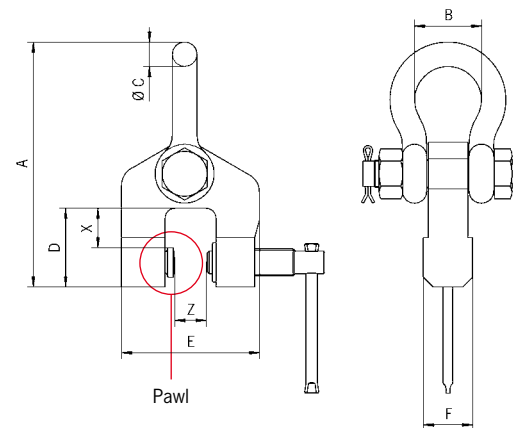

**The plate surface of the material must not exceed a hardness level of HRC 50.**

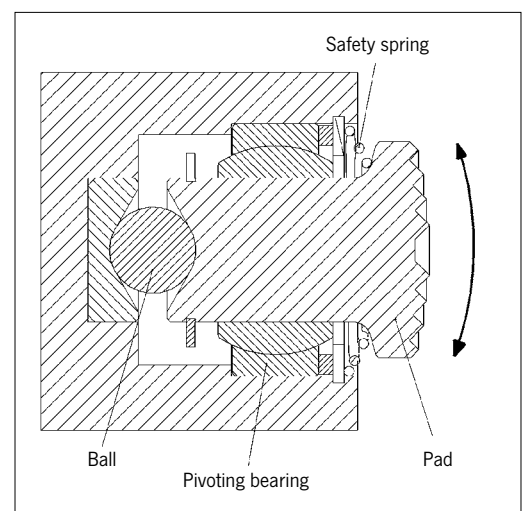

Functional drawing pivoting pad

## Screw clamp for lifting and pulling model TSD

Capacity 1500 - 7500 kg

The TSD screw clamp is a valuable asset when lifting, pulling and fitting sheet material as well as steel constructions.

The spindle is closed only finger tight.

When the screw clamp is tightened and lifting begins, the pivoting pad clamping system produces a wedging action against the material, holding it securely.



### Technical data model TSD

Model	EAN-No. 4025092*	Capacity kg	Jaw capacity Z mm	Weight kg
TSD 1,5	*550598	1500	0 - 35	4.8
TSD 3,0	*550864	3000	0 - 35	8.1
TSD 5,0	*551717	5000	0 - 40	14.5
TSD 7,5	*550987	7500	0 - 40	18.1

### Dimensions model TSD

Model	TSD 1,5	TSD 3,0	TSD 5,0	TSD 7,5
A, mm	191	235	275	295
Ø B, mm	35	46	55	65
C, mm	24	34	40	50
D, mm	16	17	18	22
E, mm	60	67	85	92
F, mm	105	120	150	162
G, mm	50	60	75	80

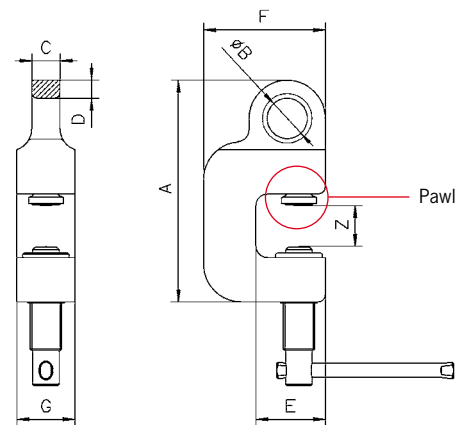

**The plate surface of the material must not exceed a hardness level of HRC 50.**

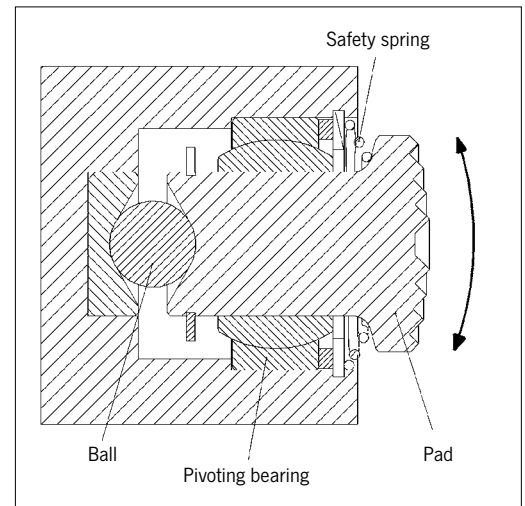

Functional drawing pivoting pad



## Screw clamp for three-dimensional pulling model TSZ

Capacity 500 - 7500 kg

The TSZ screw clamp is designed to pull in three directions. It offers many different possibilities for transporting steel constructions, feeding machining centres, etc.

The spindle is closed only finger tight. When the screw clamp is tightened and lifting begins, the pivoting pad clamping system produces a wedging action against the material, holding it securely.



**The plate surface of the material must not exceed a hardness level of HRC 50.**

### Technical data model TSZ

Model	EAN-No. 4025092*	Capacity kg	Jaw capacity mm	Weight kg
TSZ 0,5	*555739	500	0 - 28	2.3
TSZ 1,5	*555746	1500	0 - 35	5.6
TSZ 3,0	*555753	3000	0 - 35	8.8
TSZ 5,0	*555760	5000	0 - 40	16.2
TSZ 7,5	*555777	7500	0 - 40	20.9

### Dimensions model TSZ

Model	TSZ 0,5	TSZ 1,5	TSZ 3,0	TSZ 5,0	TSZ 7,5
A, mm	28	35	35	40	40
B, mm	43	60	67	85	92
C, mm	45	55	65	75	75
D, mm	125	158	195	230	240
E, mm	72	93	114	133	143
F, mm	83	99	120	150	162
Ø G, mm	26	35	46	55	65
H, mm	16	24	34	40	50
I, mm	12	16	17	18	23
J, mm	35	50	60	75	80

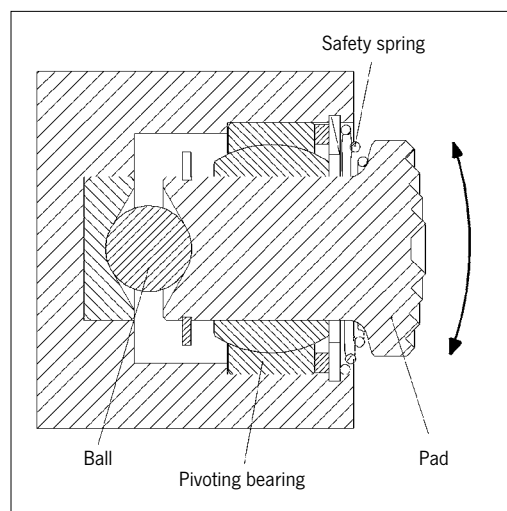
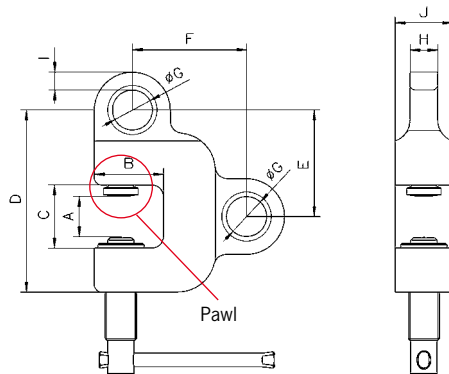

Functional drawing pivoting pad

## Roundstock grab model TRU

Capacity 100 - 4000 kg

The TRU roundstock grab picks up roundstock and pipe material up to 600 mm in diameter quickly and safely.

With its optional protective lining, it can also pick up materials with sensitive surfaces.



**!** When using protective lining, it is important that the surfaces are dry, clean and free of oil and grease.

### Technical data model TRU

Model	EAN-No. 4025092*	EAN-No. 4025092* with protective lining	Capacity kg	Jaw capacity Z mm	Weight kg
TRU 0,1/150	*550918	*551632	100	50 - 150	3.9
TRU 0,5/200	*550475	*551151	500	35 - 200	13.6
TRU 1,0/200	*550949	*552165	1000	35 - 200	13.6
TRU 1,5/300	*550505	*550512	1500	80 - 300	27.0
TRU 3,0/300	*550758	*550536	3000	80 - 300	49.0
TRU 4,0/600	*551526	*550406	4000	200 - 600	204.0

### Dimensions model TRU

Model	TRU 0,1/150	TRU 0,5/200	TRU 1,0/200	TRU 1,5/300	TRU 3,0/300	TRU 4,0/600
A, mm	270	503	509	720	740	1.420
B min., mm	292	417	437	520	582	930
B max., mm	458	723	745	937	960	1.815
C, mm	97	150	178	204	220	318
D, mm	43	56	82	84	125	205
E, mm	8	15	15	20	20	30
F, mm	17	17	30	25	30	35

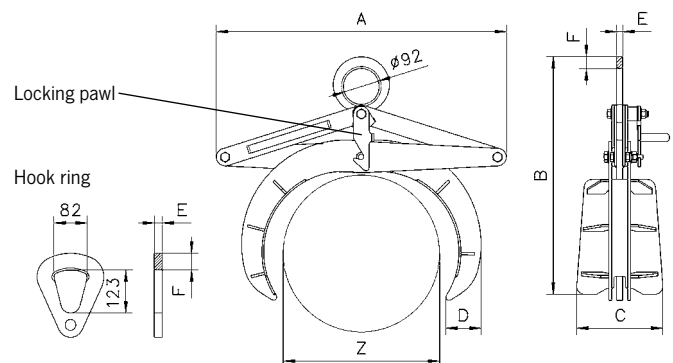

Model TRU, hook ring for grabs for 2000 kg and up capacity. Locking pawl locks open grab in place.

## Pipe grab model TR

Capacity 200 - 3000 kg

The TR pipe grab for rolls and pipes up to 1050 mm in diameter offers a large variety of different applications. Apart from pipe and drums laid on their side, this lightweight pipe grab will also handle rolls of paper, fabric, sheet metal and tubes.

The grab can be ordered with a protective lining made of "Bremsit" or hard rubber for extra protection in lifting loads with sensitive surface.



The picture shows a customized grab. Standard delivery without rollers as shown in technical drawing

**When using protective lining, it is important that the surfaces are dry, clean and free of oil and grease.**

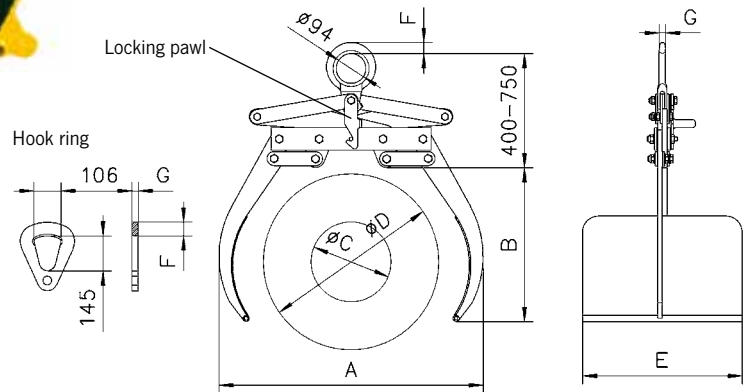

Model TR, hook ring for grabs for 2000 kg and above. Locking pawl keeps the grab in the open position.

### Technical data model TR

Model	EAN-No. 4025092*	EAN-No. 4025092* with protective lining	Capacity kg	Jaw capacity mm	Weight kg
TR 0,2/550	*553506	*552585	200	350 - 550	34
TR 0,2/650	*553513	*554978	200	450 - 650	41
TR 0,3/750	*553520	*554985	300	500 - 750	47
TR 0,5/750	*553537	*551700	500	500 - 750	47
TR 0,5/900	*553544	*552400	500	650 - 900	54
TR 0,75/1050	*552561	*554992	750	700 - 1050	56
TR 1,0/750	*553551	*555005	1000	500 - 750	55
TR 1,0/1050	*553568	*555012	1000	700 - 1050	71
TR 2,0/1050	*553575	*555029	2000	700 - 1050	135
TR 3,0/1050	*553582	*555036	3000	700 - 1050	154

### Dimensions model TR

Model	TR 0,2/550	TR 0,2/650	TR 0,3/750	TR 0,5/750	TR 0,5/900	TR 0,75/105	TR 1,0/750	TR 1,0/1050	TR 2,0/1050	TR 3,0/1050
A, mm	800	900	1100	1100	1150	1300	1000	1350	1350	1350
B, mm	565	615	665	665	765	815	665	815	815	815
Ø D, mm	550	650	750	750	900	1050	750	1050	1050	1050
E, mm	550	550	550	550	550	550	550	550	800	800
F, mm	35	35	35	35	35	35	35	35	45	45
G, mm	20	20	20	20	20	20	20	20	30	30
Ø C, mm	350	450	500	500	650	700	500	700	700	700

### Profile steel grab model TPR

Capacity 500 - 3000 kg

The TPR steel grab is designed for transport of girders, profile steel, etc. It boasts a large jaw capacity, which makes it useful for various flange widths.

The clamping jaws press securely with a positive fit to the girder.



#### Technical data model TPR

Model	EAN-No. 4025092*	Capacity kg	Jaw capacity Z mm	Weight kg
TPR 0,5/200	*551496	500	0 - 200	15.0
TPR 1,5/300	*551045	1500	0 - 300	22.6
TPR 3,0/300	*553490	3000	0 - 300	41.7

#### Dimensions model TPR

Model	TPR 0,5/200	TPR 1,5/300	TPR 3,0/300
A, mm	510	710	720
B min., mm	390	495	525
B max., mm	625	830	920
C, mm	200	200	220
D, mm	15	15	20
E, mm	30	30	43

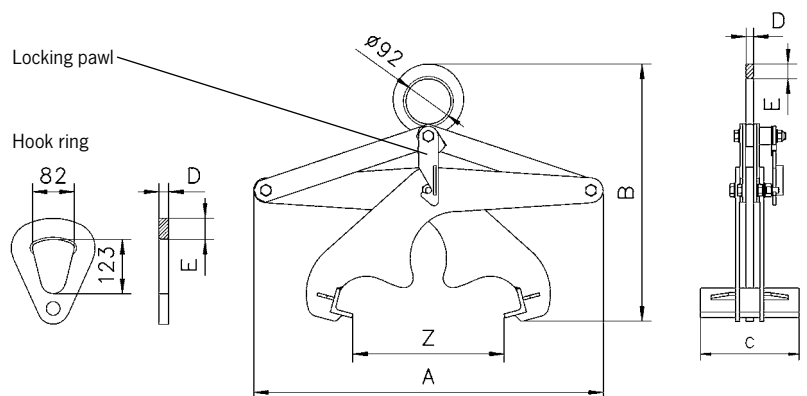

Model TPR, hook ring for grabs for 2000 kg and up capacity.  
Locking pawl locks open grab in place.



## Block grab model TVB

Capacity 250 and 500 kg

The TVB block grab is useful for the transport of stone and concrete blocks and other materials with parallel surfaces. The grab has a protective lining to ensure a safe and non-marring transport.

The clamping jaw and the center of gravity are easily and quickly adjustable by means of the locking pin.



**!** It is important that the surfaces are dry, clean and free of oil and grease.

### Technical data model TVB

Model	EAN-No. 4025092*	Capacity kg	Jaw capacity Z mm	Weight kg
TVB 500	*556989	250/500	0 - 240	13

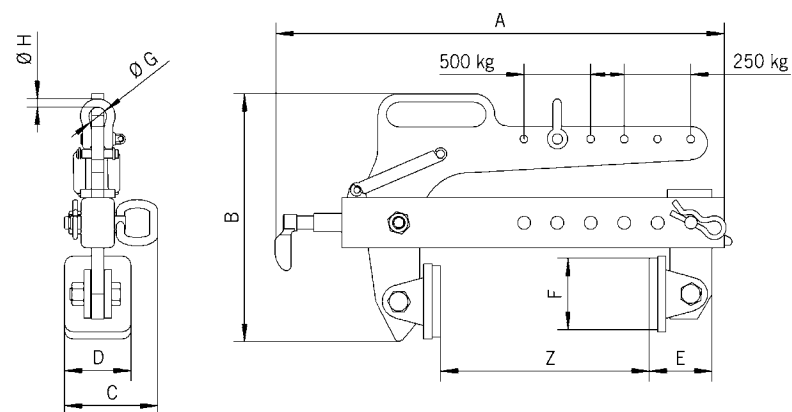

### Dimensions model TVB

Model	TVB 500
A, mm	537
B, mm	296
C, mm	112
D, mm	80
E, mm	75
F, mm	85
Ø G, mm	22
Ø H, mm	10



**Stone/concrete grab  
with small jaw capacity  
model TBG**

Capacity 200 - 2500 kg

The TBG block grabs are suited for the transport of all materials with parallel surfaces that can withstand a clamping pressure twice as high as the load being lifted.

The grabs are delivered with a replaceable hard rubber protective lining as standard.



**When using rubber protective lining it is important that the surfaces are dry, clean and free of oil and grease.**

**Technical data model TBG with small jaw capacity**

Model	EAN-No. 4025092*	Capacity kg	Jaw capacity Z mm	Weight kg
TBG 0,2/150	*552141	200	0 - 150	24
TBG 0,3/150	*553599	300	0 - 150	27
TBG 0,5/150	*552455	500	0 - 150	27
TBG 1,0/250	*552356	1000	50 - 250	50
TBG 1,5/250	*552394	1500	50 - 250	50
TBG 2,5/250	*551571	2500	50 - 250	79

**Dimensions model TBG with small jaw capacity**

Model	TBG 0,2/150	TBG 0,3/150	TBG 0,5/150	TBG 1,0/250	TBG 1,5/250	TBG 2,5/250
A, mm	815	815	815	1050	1050	1050
B min., mm	420	420	420	460	460	460
B max., mm	760	760	760	980	980	980
C, mm	200	200	200	250	250	250
D, mm	160	160	160	160	160	160
E, mm	30	30	30	29	29	29
F, mm	15	15	15	20	20	25

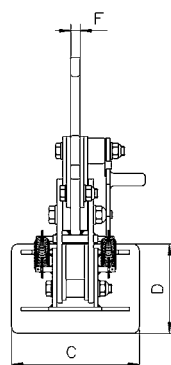
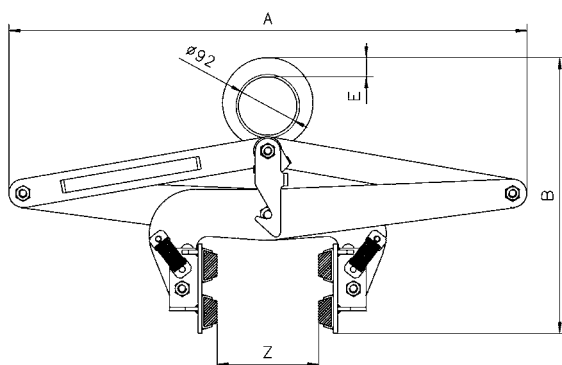



## Stone/concrete grab with large jaw capacity model TBG

Capacity 200 - 5000 kg

The units are delivered with protective linings as standard.



### Technical data model TBG with large jaw capacity

Model	EAN-No. 4025092*	Capacity kg	Jaw capacity Z mm	Weight kg
TBG 0,2/500	*551489	200	200 - 500	49
TBG 0,3/700	*551816	300	400 - 700	52
TBG 0,5/900	*552288	500	600 - 900	55
TBG 1,0/400	*553612	1000	100 - 400	51
TBG 1,0/1100	*552134	1000	800 - 1100	72
TBG 1,5/1300	*553605	1500	1000 - 1300	128
TBG 2,0/500	*553629	2000	200 - 500	126
TBG 3,0/500	*553636	3000	200 - 500	160
TBG 4,0/500	*553643	4000	200 - 500	240
TBG 5,0/500	*553650	5000	200 - 500	270

**When using rubber protective lining it is important that the surfaces are dry, clean and free of oil and grease.**

### Dimensions model TBG with large jaw capacity

Model	TBG 0,2/500	TBG 0,3/700	TBG 0,5/900	TBG 1,0/400	TBG 1,0/1100	TBG 1,5/1300	TBG 2,0/500	TBG 3,0/500	TBG 4,0/500	TBG 5,0/500
A**, mm	1040	1040	1120	1040	1320	1520	1100	1100	1100	1100
B min., mm	390	390	390	390	390	390	530	530	600	600
B max., mm	840	840	840	840	840	840	1120	1120	1190	1190
C, mm	275	275	275	250	275	275	250	250	250	250
D, mm	160	160	160	160	160	160	160	160	160	160
E, mm	300	300	300	300	300	300	350	350	350	350
F, mm	35	35	35	35	35	35	36	42	48	48
G, mm	20	20	20	20	20	20	25	30	35	35

\*\*Scissor dimensions

Model TBG with large jaw capacity, lug suspension for grabs with 2000 kg and above.

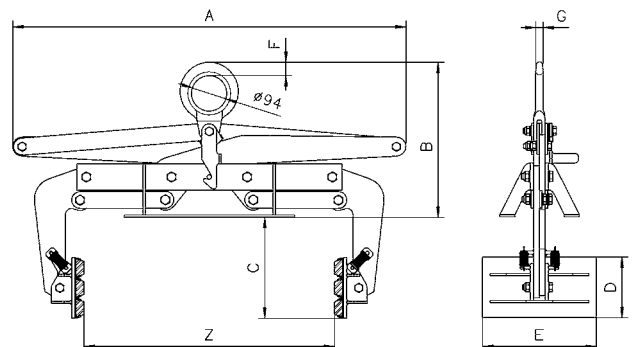
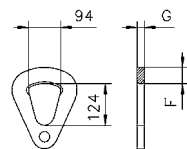

### Bale grab model TBA

Capacity 200 - 1000 kg

The TBA bale grab transports bales of fiber, wool, fabric, paper, pressed straw and various types of shavings up to a width of 1.3 m. Bales are gripped safely yet gently, and where applicable, the clamps are lined with a soft and pliable material.

The locking pawl only engages if the grab is opened without manual intervention.



- ! The standard grab is equipped with protective linings.
- Serrated jaws available on request.

### Technical data model TBA

Model	EAN-No. 4025092*	Capacity kg	Jaw capacity Z mm	Weight kg
TBA 0,2/700	*553667	200	250 - 700	40
TBA 0,3/900	*552080	300	450 - 900	42
TBA 0,5/1100	*552776	500	650 - 1100	45
TBA 0,75/1300	*552035	750	850 - 1300	62
TBA 1,0/1300	*553674	1000	850 - 1300	62

### Dimensions model TBA

Model	TBA 0,2/700	TBA 0,3/900	TBA 0,5/1100	TBA 0,75/1300	TBA 1,0/1300
A, mm	890	1090	1290	1550	1550
B, mm	420	420	420	420	420
C, mm	500	500	500	500	500
D, mm	35	35	35	35	35
E, mm	20	20	20	20	20

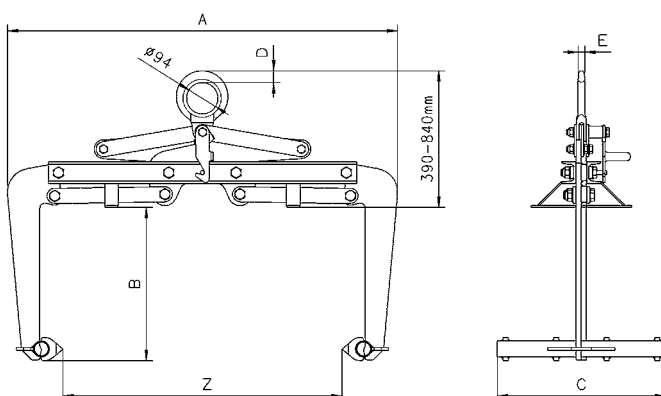

Model TBA 0,2-1 t with serrated jaw



## Rail grab with safety lock model TCR

Capacity 1000 - 2000 kg

The TCR rail grab transports rails, as used by railways, easily and safely. A safe grip is ensured by the lever operated safety lock. For long rails, two grabs must be attached to a spreader beam to avoid sagging.

Since the rails are primarily grabbed with positive fit, it is important that the clamp stays in a vertical position during initial lift.

**A TCR multiple rail system is also available for the simultaneous transport of up to 12 rails.**

**For special sizes please advise rail type and profile.**

### Technical data model TCR

Model	EAN-No. 4025092*	Capacity kg	Weight kg
TCR 1,0	*550802	1000	12.4
TCR 2,0	*551076	2000	13.9

### Dimensions model TCR

Model	TCR 1,0	TCR 2,0
A*, mm	144	144
B, mm	152	163
C, mm	350	350
D, mm	90	90
E, mm	46	46
Ø F, mm	20	20
G, mm	25	25

\*Scissor dimensions

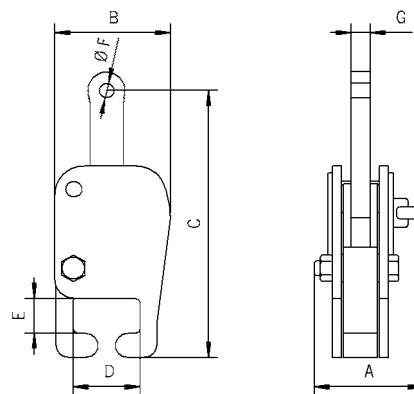

## Inside grab model TDI

Capacity 100 - 5000 kg

Inside grabs are available in three versions for the handling of cylindrical and rectangular hollow bodies. The clamping jaws are available with optional steel jaws, hard manganese serrated jaws or jaws with protective lining, which are designed to grab a variety of shapes and materials. These inside grabs can be equipped with an automatic opening and closing device. Ideal especially for wire coils and hollow bodies.



- ! For inside grabs with jaws with protective lining, the inside surface of the material must be free of oil and grease.
- When ordering, please advise the requested version.

### Technical data model TDI

Model	EAN-No. 4025092*	Capacity kg	Jaw capacity mm	Weight kg
TDI 0,1/420	*551410	100	220 - 420	17
TDI 0,5/600	*552066	500	400 - 600	51
TDI 1,0/600	*553704	1000	400 - 600	53
TDI 2,0/800	*553711	2000	550 - 800	150
TDI 3,0/800	*553728	3000	550 - 800	175
TDI 5,0/800**	*553735	5000	550 - 800	220

\*\*with hard manganese serrated jaws

### Dimensions model TDI

Model	TDI 0,1/420	TDI 0,5/600	TDI 1,0/600	TDI 2,0/800	TDI 3,0/800	TDI 5,0/800
A, mm	790	1200	1200	1400	1450	1450
B, mm	455	610	600	830	920	795
C, mm	550	800	900	1100	1000	1000
D, mm	80	100	100	120	160	160
E, mm	90	160	160	220	220	65
F, mm	-	-	-	124	151	151
G, mm	Ø 60	Ø 92	Ø 92	83	107	107
H, mm	15	15	15	30	30	35
I, mm	22	30	30	42	42	42

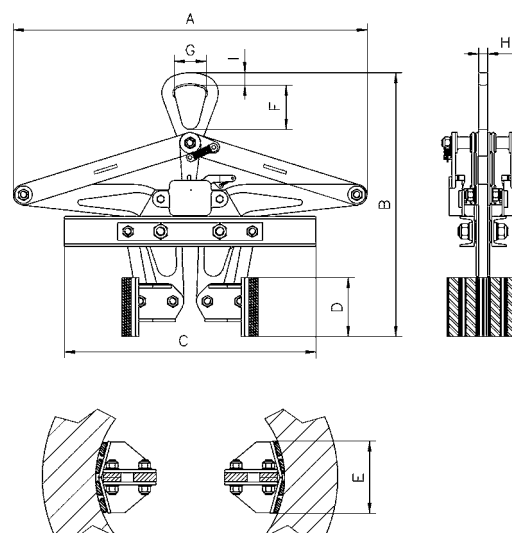





Model TCU



Model TCO

## Container lifting lugs model TCO and model TCU

Capacity 32000 - 56000 kg

These container lifting lugs are offered in a set of 4 pieces with a total weight capacity of 56 t.

The lugs serve as flexible attachment points for the transport of containers. Two types are available which can be fastened to either the "top" of the container or laterally.

Model TCO is vertically mounted in the hole at the top of the container. Turning the TCO 90°, locks it securely in place.

Transport is done with the use of a spreader beam in conjunction with wire rope, chain or textile slings making sure the load is suspended vertically.

Model TCU is mounted laterally on the container (in the upper or the lower part) and has a spring-loaded bolt to prevent an accidental release.

Transport is done with the use of a spreader beam in conjunction with wire rope, chain or textile slings up to the below mentioned angles from the vertical.



Container lifting lugs model TCO



Container lifting lugs model TCU

### Technical data model TCO and model TCU

Model	EAN-No. 4025092*	Capacity** kg	Weight** kg	Angle from the vertical
TCU 32	*556927	32000	19.5	50°
TCU 40	*556927	40000	19.5	36°
TCO 56	*556965	56000	30.1	vertical

\*\*set of 4 pieces

### Dimensions model TCO and model TCU

Model	TCU 32	TCU 40	TCO 56
A, mm	152	152	123
B, mm	181	181	217
Ø C, mm	45	45	45
D, mm	37	37	39
E, mm	73	73	57
F, mm	75	75	101
G, mm	40	40	121

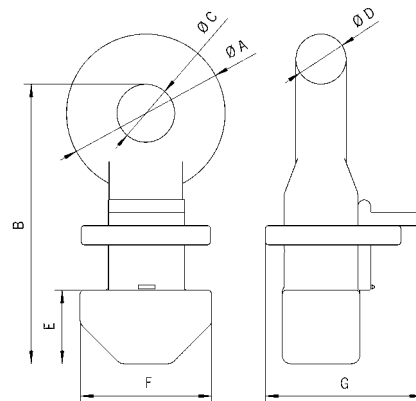

Model TCO

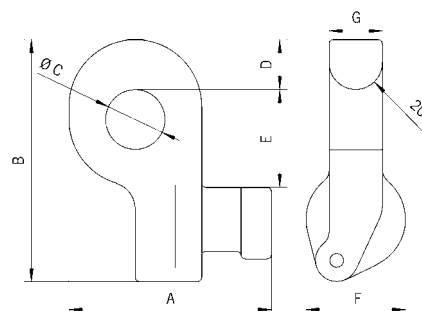

Model TCU

Beam clamp model YC

Capacity 1000 - 10000 kg



Trolley clamp model CTP

Capacity 1000 - 3000 kg



Push and geared type model HTP and model HTG

Capacity 500 - 20000 kg



Swivel truck trolley with low headroom and extremely short curve radius model VLHP and model VLHG

Capacity 250 - 6000 kg



Electric trolley model VTE-U

Capacity 1000 - 5000 kg



! Information about beam clamps and trolleys are presented in the hoisting chapter, pages 46 et. seqq.



## C-Hook model TCK

### Capacity 500 - 10000 kg

Coils, rolls, rings and similar items are transported safely with the Tigrip C-Hooks. Tine length and usable height with the most frequently encountered coil sizes are listed in the table below.

Other working loads, measurements, and models, such as C-Hooks with automatic balancing device, are available on request.

! Illustration shows tines with 4/4 the length of the coil width (special).

### Technical data model TCK

Model	EAN-No. 4025092*	Capacity kg	Weight kg
TCK 0,5/300	*554800	500	21
TCK 0,5/500	*552417	500	30
TCK 0,5/800	*554817	500	46
TCK 1,0/300	*554824	1000	28
TCK 1,0/500	*554831	1000	40
TCK 1,0/800	*552783	1000	95
TCK 2,0/300	*554848	2000	45
TCK 2,0/500	*551830	2000	90
TCK 2,0/800	*552615	2000	140
TCK 2,0/1000	*552479	2000	180
TCK 3,0/300	*554855	3000	68
TCK 3,0/500	*554862	3000	127
TCK 3,0/800	*552431	3000	165
TCK 3,0/1000	*554879	3000	215
TCK 5,0/500	*551298	5000	184
TCK 5,0/800	*554886	5000	238
TCK 5,0/1000	*554893	5000	286
TCK 5,0/1250	*554909	5000	364
TCK 7,5/800	*555043	7500	390
TCK 7,5/1000	*551984	7500	520
TCK 7,5/1250	*551878	7500	650
TCK 7,5/1500	*554916	7500	767
TCK 10,0/1000	*554923	10000	772
TCK 10,0/1250	*551670	10000	810
TCK 10,0/1500	*554930	10000	980

Dimensions model TCK

Model	TCK 0,5/300	TCK 0,5/500	TCK 0,5/800	TCK 1,0/300	TCK 1,0/500	TCK 1,0/800	TCK 2,0/300	TCK 2,0/500	TCK 2,0/800	TCK 2,0/1000
Coil width A, mm	300	500	800	300	500	800	300	500	800	1000
Usable height B, mm	400	400	400	450	450	450	500	500	500	500
C, mm	570	580	580	620	630	630	700	700	720	720
D, mm	60	60	60	60	60	60	75	75	75	75
E, mm	120	120	120	120	120	120	150	150	150	150
F, mm	20	20	25	25	20	30	25	30	30	20
G, mm	25	23	23	23	23	23	38	38	38	35
H, mm	20	20	25	20	25	30	25	30	30	40
I, mm	50	65	70	70	80	90	90	110	125	125

Model	TCK 3,0/300	TCK 3,0/500	TCK 3,0/800	TCK 3,0/1000	TCK 5,0/500	TCK 5,0/800	TCK 5,0/1000	TCK 5,0/1250	TCK 7,5/800	TCK 7,5/1000
Coil width A, mm	300	500	800	1000	500	800	1000	1250	800	1000
Usable height B, mm	500	500	500	500	550	550	550	550	600	600
C, mm	700	700	720	720	800	800	820	820	900	900
D, mm	75	75	75	75	100	100	100	100	110	110
E, mm	150	150	150	150	200	200	200	200	220	220
F, mm	30	20	25	20	25	30	30	30	35	35
G, mm	38	40	40	40	45	45	45	45	50	50
H, mm	30	30	40	40	40	50	50	50	50	60
I, mm	105	125	140	155	145	160	180	200	200	200

Model	TCK 7,5/1250	TCK 7,5/1500	TCK 10,0/1000	TCK 10,0/1250	TCK 10,0/1500
Coil width A, mm	1250	1500	1000	1250	1500
Usable height B, mm	600	600	650	650	650
C, mm	900	920	980	1000	1000
D, mm	110	110	130	130	130
E, mm	220	220	250	250	250
F, mm	35	35	40	45	45
G, mm	45	50	50	55	55
H, mm	60	70	70	70	80
I, mm	220	220	220	240	240

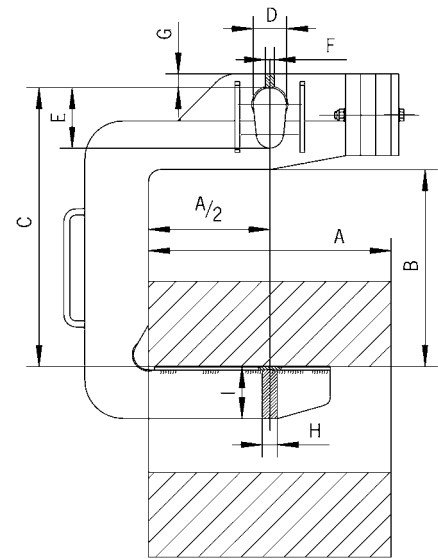

**!** Standard model has tines  $\frac{3}{4}$  the length of the coil width as shown in the drawing.



## Coil hook model TCS

### Capacity 500 - 3000 kg

The TCS coil hook is an universal C-Hook. Due to its tipping feature, it can lift or lower the coil, whether the coil is lying flat or is in an upright position. With this tipping device, the coil is tipped safely through 90°.

The slow and safe movement of the tipping device ensures a continuous flowing movement when lifting or lowering the coil. At the same time, the tipping device serves the purpose of preventing accidental slipping of the load during transport.

Other sizes and models available on request.



### Technical data model TCS

Model	EAN-No. 4025092*	Capacity kg	Weight kg
TCS 0,5/120	*554947	500	6.9
TCS 0,5/200	*552257	500	9.6
TCS 1,0/200	*552264	1000	15.4
TCS 1,0/300	*552875	1000	20.0
TCS 2,0/200	*551977	2000	24.8
TCS 2,0/300	*551908	2000	33.4
TCS 3,0/200	*552011	3000	45.0
TCS 3,0/300	*552714	3000	51.0

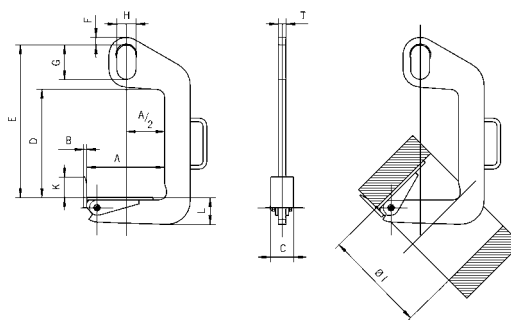

### Dimensions model TCS

Model	TCS 0,5/120	TCS 0,5/200	TCS 1,0/200	TCS 1,0/300	TCS 2,0/200	TCS 2,0/300	TCS 3,0/200	TCS 3,0/300
Coil width A min, mm	50	100	100	200	100	200	100	200
Coil width A max., mm	120	200	200	300	200	300	200	300
B, mm	10	10	10	10	12	12	15	15
C, mm	60	60	80	80	90	90	100	100
D, mm	330	330	460	460	420	420	610	610
E, mm	470	470	600	600	600	600	820	820
F, mm	20	20	20	20	30	30	40	40
G, mm	110	110	110	110	135	135	160	160
H, mm	60	60	60	60	75	75	90	90
K, mm	50	50	60	60	80	80	100	100
L, mm	45	50	65	70	85	95	100	110
T, mm	20	20	25	25	30	30	35	35
Ø I, mm	220	300	300	400	300	400	300	400

## Barrel grab for transport of upright barrels model TFA

### Capacity 300 kg

This unit grabs upright barrels and sets them down in the same position. Although the clamping jaws are fitted with a hard rubber lining to provide a friction hold, it is the positive fit on the rim that provides extra safety. This additional feature is indispensable if the surface of the barrels is stained with oil or grease.

The clamping jaws fitted with a protective lining enable the non-marring and secure grab around the circumference of the barrel. The clamp is suitable for standard type barrels.



### Technical data model TFA

Model	EAN-No. 4025092*	Capacity kg	Jaw capacity Z diameter mm	Weight kg
TFA 0,3/600	*557009	300	400 - 600	57



### Dimensions model TFA

Model	TFA 0,3/600
A, mm	600
B, mm	1040
C, mm	950
Ø D, mm	90
E, mm	34
F, mm	15
G, mm	200
H, mm	400
I, mm	400

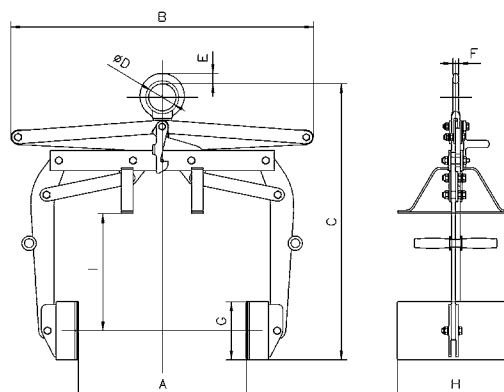

**!** For barrels according to EN ISO 15750-2.





For barrels according to EN ISO 15750-2.

## Barrel grab with tipping device model TFA D

Capacity 300 kg

The grab with tipping device is suited to lift, transport as well as tipping and emptying the barrel.

In order to tip the barrel easily, it must be picked up at the correct center of gravity.



### Technical data model TFA D

Model	EAN-No. 4025092*	Capacity kg	Jaw capacity Z diameter mm	Weight kg
TFA 0,3/600 D	*557917	300	400 - 600	83

### Dimensions model TFA D

Model	TFA 0,3/600 D
A, mm	600
B, mm	1150
C, mm	1525
Ø D, mm	90
E, mm	34
F, mm	15
G, mm	200
H, mm	400

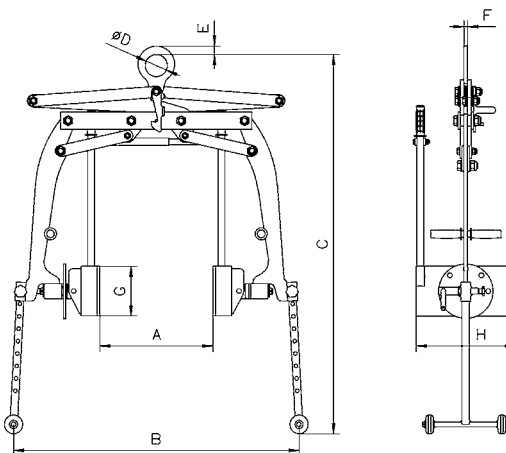

**Barrel grab**  
**model TFA 0,35/700 R**  
**and TFA 0,35/700 TR**

Capacity 350 kg

These barrel grabs are designed for transport of steel barrels. The clamping jaws press securely with a positive fit underneath the rim of the barrel.



Model TFA-R



Model TFA-TR

**TFA 0,35/700 TR is a combination unit for the transport of barrels that can be used with either an overhead crane or forklift.**

**For barrels according to EN ISO 15750-2.**

**Technical data model TFA R/TR**

Model	EAN-No. 4025092*	Capacity kg	Jaw capacity Z diameter mm	Weight kg
TFA 0,35/700 R	*551014	350	420 - 700	5.7
TFA 0,35/700 TR	*551472	350	420 - 700	9.2

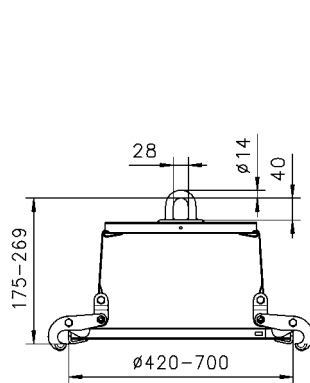

Model TFA-R

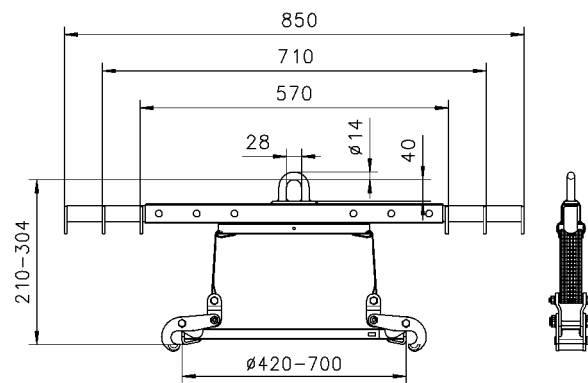

Model TFA-TR

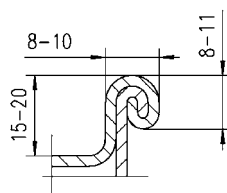

Relevant barrel dimensions



## Barrel rim clamp model TFRK

Capacity 500 kg

The TFRK barrel rim clamp can be used individually, as a pair, or as a multi-legged chain sling.

The clamp grabs under the rim of the barrel. A spring-loaded cam prevents the accidental opening of the clamp.

**!** For barrels according to EN ISO 15750-2.

### Technical data model TFRK

Model	EAN-No.	Capacity	Weight
	4025092*	kg	kg
TFRK	*556415	500	1.5

### Dimensions model TFRK

Model	TFRK 0,5
A, mm	152
B, mm	150
C, mm	127
D, mm	30
E, mm	21
F, mm	41
G, mm	17
Ø H, mm	40

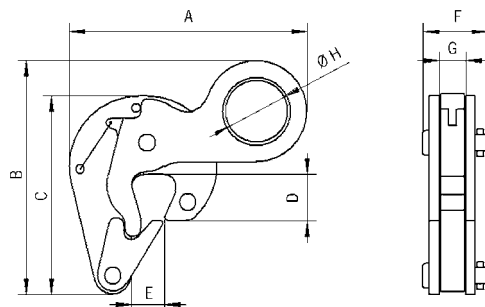

### Barrel clamp model TFK

Capacity 500 kg

Its light weight and small overall design makes it ideal for lifting barrels where access or space is limited.

The center of gravity of the barrel is the lifting point during transport.



**!** For barrels according to EN ISO 15750-2.

#### Technical data model TFK

Model	EAN-No. 4025092*	Capacity kg	Weight kg
TFK 0,5	*556071	500	7.3

#### Dimensions model TFK

Model	TFK 0,5
A, mm	479
B, mm	350
C, mm	410
D, mm	300
Ø E, mm	50

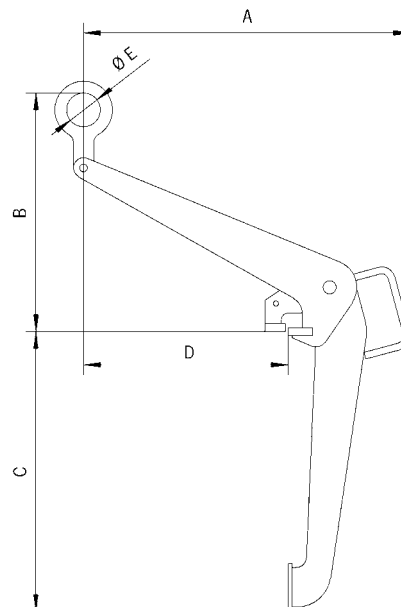



## Crate grab with tipping device model TKA/d

Capacity 150 kg

The crate grab with tipping device is an absolutely safe unit, which not only securely transports stacking boxes, but can empty them in mid-air as well.

A safety lever system prevents the accidental opening of the grab.

The clamping jaws tightly grab under the rim of the crate without damaging the crate. To engage the tipping motion in order to empty the crate, the safety lock must be manually unlocked. The tipping motion is limited to 100°. This prevents the crate from flipping completely over while emptying, thereby reducing the risk of injury.

### Options

- Grabs for other sizes of crates.

**!** Please provide the crate dimensions or a sample crate when ordering.

### Technical data model TKA/d

Model	EAN-No. 4025092*	Capacity kg	Weight kg
TKA 0,15/330d	*551519	150	25.8
TKA 0,15/480d	*552103	150	26.0

### Dimensions model TKA/d

Model	TKA 0,15/330d	TKA 0,15/480d
A, mm	200 - 300	300
B, mm	315 - 330	470 - 480
L, mm	465 - 540	550 - 660

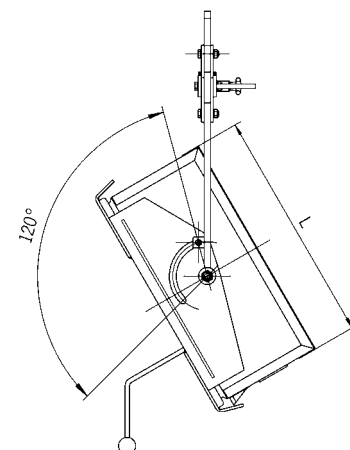
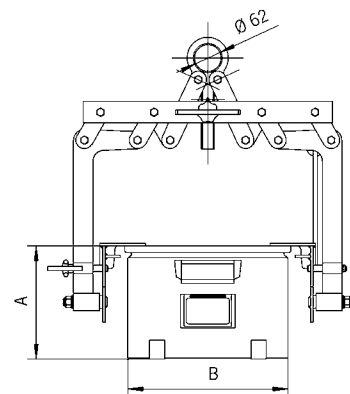

## Crate grab model TKA a/i

Capacity 250 kg

The easy-handling crate grab, which grabs on the side plates or the front sides of the crate, transports crates safely and without damaging them.

The moveable jaws press the edge of the crate gently against the outside grab support rails. Stacking boxes made of steel or plastic will not get deformed. After the box has been set down, the safety device holds the grab open.

When lifting the crate and grabbing the support rails, the safety device must be manually pulled back until it lies over the safety bolt. With further lifting, the jaws grab under the outer top edge of the crate and lift it up safely.

The crate grab is available as an external or internal operating grab.



Model TKA.../...a external operating



Model TKA.../...i internal operating



Model TKA.../...i internal operating

**Please provide the crate dimensions or a sample crate when ordering.**

### Technical data model TKA a/i

Model	EAN-No. 4025092*	Capacity kg	Weight kg	Jaw capacity mm
TKA 0,25/320a	*558082	250	9.3	320
TKA 0,25/480a	*558044	250	9.3	480
TKA 0,25/600a	*558099	250	9.3	600
TKA 0,25/320i	*558051	250	8.5	320
TKA 0,25/480i	*558068	250	8.5	480
TKA 0,25/600i	*558075	250	8.5	600

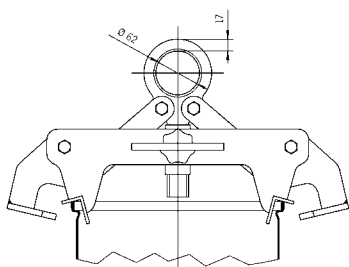

Model TKA.../...a external operating

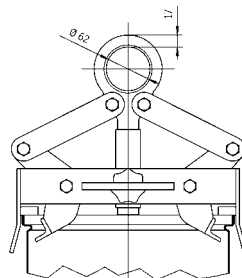
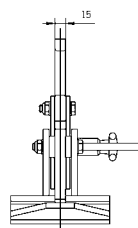

Model TKA.../...i internal operating

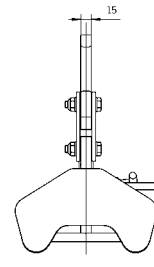





## Concrete pipe lifting gear model BTG

Capacity 1500 - 3000 kg

Lifting gear for the vertical transport of concrete pipe and culverts must be very versatile. Most important, it must be absolutely safe and easy to handle under even the harshest conditions.

The Tigrip concrete pipe lifting gear meets all these requirements. It is a three legged lifting system for the safe and non-marring transport of concrete pipes up to a diameter of Ø 2000 mm and a load of up to 3 t.

The jaw capacity is designed for concrete pipe thicknesses from 40 - 220 mm. Attachment and removal of the clamps can be done easily due to the handles that have been incorporated into each clamp.

### Features

- Solid design
- Safety factor 4:1
- Simple and safe handling
- Large jaw capacity
- For the toughest operating conditions
- Lightweight design
- Service-friendly

For concrete pipes according to DIN 4034.

Lifting gear for concrete pipe up to a diameter of Ø 3000 mm available on request.



### Technical data model BTG

Model	EAN-No. 4025092*	Capacity** kg	Jaw capacity Z mm	Mouth depth E mm	Pressure line F mm	Weight kg
BTG 1,5/120	*550147	1500	40 - 120	165	100	35
BTG 3,0/180 TM-N	*551199	3000	50 - 180	245	175	90
BTG 3,0/220 TM-N	*550819	3000	90 - 220	245	175	94

\*\*Per lifting gear - three legged

### Dimensions model BTG

Model	BTG 1,5/120	BTG 3,0/180 TM-N	BTG 3,0/220 TM-N
A, mm	135	180	180
B, mm	75	100	100
Ø C, mm	18	26	26
D, mm	180	310	310

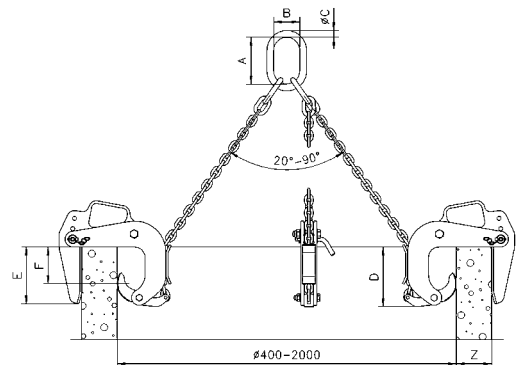

## Trench shield grab model TCP

Capacity 1500 - 5500 kg

The TCP grab is suitable for vertical positioning and transportation of trench shields.

Once the grab is set onto the trench shield, a spring-loaded bolt locks itself into the hole of the shield. Releasing the bolt is done with the 15 m pull cord attached to the grab.



### Technical data model TCP

Model	EAN-No. 4025092*	Capacity kg	Weight kg
TCP 1,5	*555807	1500	12.2
TCP 3,0	*555791	3000	19.5
TCP 5,5	*555784	5500	26.7

### Dimensions model TCP

Model	TCP 1,5	TCP 3,0	TCP 5,5
A, mm	207	226	269
B, mm	488	517	575
C, mm	218	218	218
D, mm	90	100	120
E, mm	18	24	24
Ø F, mm	20	24	30
G, mm	180	180	180
Ø H, mm	50	63	89

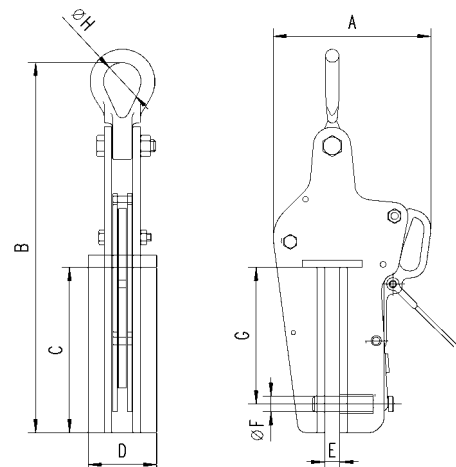



## Trench shield clamp model TPP

Capacity 3000 - 12000 kg

The TPP trench shield clamp is similar to a regular plate clamp in its construction but has a much deeper jaw.

The compact construction combined with a high capacity makes it ideal for pulling trench shields out of the ground.

A safety lock prevents the accidental opening of the clamp.

### Technical data model TPP

Model	EAN-No. 4025092*	Capacity kg	Jaw capacity mm	Weight kg
TPP 3	*556255	3000	0 - 20	16.0
TPP 8	*556217	8000	0 - 30	27.8
TPP 12	*556231	12000	0 - 30	53.0

### Dimensions model TPP

Model	TPP 3	TPP 8	TPP 12
A, mm	224	294	361
B, mm	325	445	486
Ø C, mm	20	30	40
D, mm	88	109	145
E, mm	147	194	190
F, mm	25	42	41
G, mm	123	146	167
H, mm	60	72	90
I, mm	20	25	30
J, mm	18	26	32

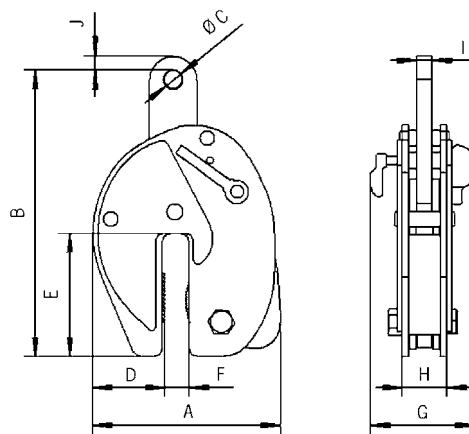

## Pipe hook model TRO

Capacity 2000 - 10000 kg

The pipe hooks are used in pairs for the safe transport of pipes.

### Scope of delivery

The shackles are included with the hooks.



### Technical data model TRO for 60° - 90° chain-top angle

Model	EAN-No. 4025092*	Capacity** kg	Weight** kg
TRO 2/90	*556729	2000	3.1
TRO 4/90	*556743	4000	5.6
TRO 6/90	*556767	6000	10.5
TRO 8/90	*556781	8000	17.8
TRO 10/90	*556804	10000	22.0

\*\*Per pair

### Dimensions model TRO for 60° - 90° chain-top angle

Model	TRO 2/90	TRO 4/90	TRO 6/90	TRO 8/90	TRO 10/90
t, mm	20	30	30	40	40
A, mm	0 - 40	0 - 50	0 - 60	0 - 70	0 - 80
B, mm	35	40	51	55	69
C, mm	40	48	62	67	80
D, mm	62	77	90	105	115
E, mm	62	77	90	105	115
F, mm	116	142	173	190	221
Ø G, mm	16.3	24.3	24.3	30.3	30.3
H, mm	47.6	72.2	72.2	95.3	95.3
Ø I, mm	12.7	19	19	25.4	25.4
J, mm	30.2	44.5	44.5	58.7	58.7

### Technical data model TRO for 90° - 120° chain-top angle

Model	EAN-No. 4025092*	Capacity** kg	Weight** kg
TRO 2/120	*556828	2000	3.5
TRO 4/120	*556842	4000	8.8
TRO 6/120	*556866	6000	14.9
TRO 8/120	*556880	8000	18.6
TRO 10/120	*556903	10000	23.0

\*\*Per pair

### Dimensions model TRO for 90° - 120° chain-top angle

Model	TRO 2/120	TRO 4/120	TRO 6/120	TRO 8/120	TRO 10/120
t, mm	20	30	40	40	50
A, mm	0 - 30	10 - 40	20 - 50	30 - 65	30 - 75
B, mm	34	39	43	54	60
C, mm	40	50	55	65	70
D, mm	82	95	106	119	143
E, mm	75	80	95	100	125
F, mm	106	131	153	185	208
Ø G, mm	16.3	24.3	30.3	30.3	36.3
H, mm	30.2	44.5	58.7	58.7	73
Ø I, mm	12.7	19	25.4	25.4	31.8
J, mm	47.6	72.2	95.3	95.3	117

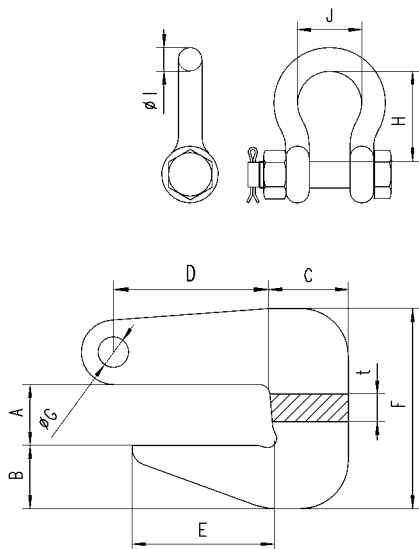



## Clamps for cable drums model TKB

Capacity 5000 kg

Specifically designed for the transport of cable drums, these clamps are used in pairs together with a two-legged chain sling.

By the spreading of the clamp, it locks inside the drum.

The clamps can be held in place by a locking lever.

Easy handling, light-weight design, and the size of the clamp contribute to a safe transport of all types of cable drums.

! Various sizes are available on request.  
Please supply dimensions C and D.

### Technical data model TKB

Model	EAN-No. 4025092*	Capacity** kg	Weight kg
TKB	*556606	5000	11

\*\*Per pair

### Dimensions model TKB

Model	TKB
A, mm	277
B, mm	277
Ø C, mm	82
D, mm	85
Ø E, mm	50

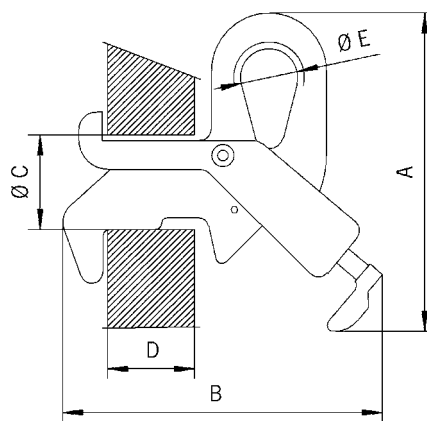

### Tine hook model TZH

Capacity 1500 - 10000 kg

For fastening hoisting equipment and loads to forklift tines.

The TZH are pushed onto the forklift tines and are fastened with two spindles. The pivoting as well as swivelling hook with safety latch ensures safety while lifting.



**Attention must be paid to the working load limit of the single forklift tines.**

#### Technical data model TZH

Model	EAN-No. 4025092*	Capacity kg	Weight kg
TZH 1,5/150	*557566	1500	7.2
TZH 3,0/150	*557580	3000	10.8
TZH 5,0/150	*557603	5000	17.3
TZH 5,0/200	*557627	5000	24.7
TZH 10,0/200	*557641	10000	43.0

#### Dimensions model TZH

Model	TZH 1,5/150	TZH 3,0/150	TZH 5,0/150	TZH 5,0/200	TZH 10,0/200
A, mm	100	100	100	150	150
B, mm	150	150	150	200	200
C min., mm	310	350	350	440	440
C max., mm	360	400	400	490	490
D, mm	260	270	295	320	420
E, mm	74	74	74	94	94
F, mm	120	120	120	180	180
G, mm	25	28	34	34	45

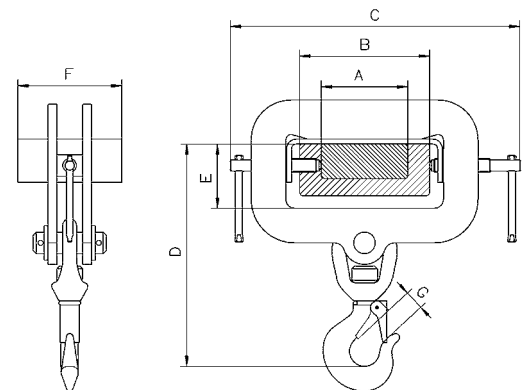

Model TZH, swivel hooks, pivoting and swivelling





## Spreader beam, non-adjustable model TTS-E

Capacity 1000 - 10000 kg

Tigrip spreader beams are the practical and safe choice for either long material to prevent sagging and shifting, or for loads where the weight has to be carefully distributed or suspended from several points. The extensive standard program offers a wide variety of capacities, working widths, adjustable ranges and hooks for common applications.

This heavy-duty and cost-effective standard type is complemented by various customized designs. These may be spreader beams with hooks for plate material, or with C-hooks, crane forks, or grabs for bulky and long materials.

Special designs with laterally fixed hooks are fitted with slings to pick up rolls, pipes and similar objects. Also available are the so-called "star" spreader beams for picking up cylindrical materials or spreader beams with side hooks and 4-point support which share the easy operation, reliability and safety of all Tigrip spreader beams.

! Customised models see page 212-213.

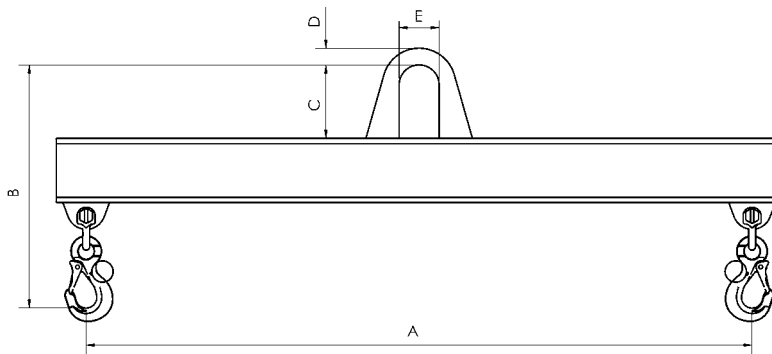

Technical data model TTS-E

Model	EAN-No. 4025092*	Capacity kg	Working width A mm	Hook mouth mm	Weight kg
TTS 1,0/1000 E	*552905	1000	1000	23	23
TTS 2,0/1000 E	*554534	2000	1000	23	25
TTS 3,0/1000 E	*552813	3000	1000	30	28
TTS 5,0/1000 E	*554541	5000	1000	38	41
TTS 7,5/1000 E	*554558	7500	1000	42	50
TTS 10,0/1000 E	*554565	10000	1000	42	61
TTS 1,0/1500 E	*552851	1000	1500	23	31
TTS 2,0/1500 E	*554572	2000	1500	23	33
TTS 3,0/1500 E	*552028	3000	1500	30	41
TTS 5,0/1500 E	*552172	5000	1500	38	64
TTS 7,5/1500 E	*554589	7500	1500	42	74
TTS 10,0/1500 E	*554596	10000	1500	42	90
TTS 1,0/2500 E	*554602	1000	2500	23	46
TTS 2,0/2500 E	*552769	2000	2500	23	69
TTS 3,0/2500 E	*552202	3000	2500	30	88
TTS 5,0/2500 E	*552493	5000	2500	38	106
TTS 7,5/2500 E	*554619	7500	2500	42	148
TTS 10,0/2500 E	*554626	10000	2500	42	181
TTS 1,0/3500 E	*554633	1000	3500	23	77
TTS 2,0/3500 E	*554640	2000	3500	23	118
TTS 3,0/3500 E	*552592	3000	3500	30	138
TTS 5,0/3500 E	*554657	5000	3500	38	167
TTS 7,5/3500 E	*554664	7500	3500	42	235
TTS 10,0/3500 E	*554671	10000	3500	42	272
TTS 1,0/5000 E	*554688	1000	5000	23	163
TTS 2,0/5000 E	*552523	2000	5000	23	189
TTS 3,0/5000 E	*554695	3000	5000	30	223
TTS 5,0/5000 E	*554701	5000	5000	38	295
TTS 7,5/5000 E	*554718	7500	5000	42	372
TTS 10,0/5000 E	*554725	10000	5000	42	478

Dimensions model TTS-E

Model	TTS 1,0/1000 E	TTS 2,0/1000 E	TTS 3,0/1000 E	TTS 5,0/1000 E	TTS 7,5/1000 E	TTS 10,0/1000 E	TTS 1,0/1500 E	TTS 2,0/1500 E	TTS 3,0/1500 E	TTS 5,0/1500 E
B, mm	375	400	470	585	690	770	375	400	490	605
C, mm	110	135	160	180	200	260	110	135	160	180
D, mm	25	30	35	40	60	70	25	30	35	40
E, mm	60	75	90	100	130	130	60	75	90	100

Model	TTS 7,5/1500 E	TTS 10,0/1500 E	TTS 1,0/2500 E	TTS 2,0/2500 E	TTS 3,0/2500 E	TTS 5,0/2500 E	TTS 7,5/2500 E	TTS 10,0/2500 E	TTS 1,0/3500 E	TTS 2,0/3500 E
B, mm	710	790	375	440	530	625	750	830	405	460
C, mm	200	260	110	135	160	180	200	260	110	135
D, mm	60	70	25	30	35	40	60	70	25	30
E, mm	130	130	60	75	90	100	130	130	60	75

Model	TTS 3,0/3500 E	TTS 5,0/3500 E	TTS 7,5/3500 E	TTS 10,0/3500 E	TTS 1,0/5000 E	TTS 2,0/5000 E	TTS 3,0/5000 E	TTS 5,0/5000 E	TTS 7,5/5000 E	TTS 10,0/5000 E
B, mm	550	665	770	850	445	480	570	685	790	890
C, mm	160	180	200	260	110	135	160	180	200	260
D, mm	35	40	60	70	25	30	35	40	60	70
E, mm	90	100	130	130	60	75	90	100	130	130



## Spreader beam, adjustable model TTS

Capacity 1000 - 25000 kg

### Technical data model TTS

Model	EAN-No. 4025092*	Capacity kg	Working width Z mm	Hook mouth mm	Weight kg
TTS 1,0/1500	*552646	1000	700 - 1500	18	40
TTS 2,0/1500	*552295	2000	700 - 1500	18	41
TTS 3,0/1500	*553988	3000	700 - 1500	21	53
TTS 5,0/1500	*551281	5000	700 - 1500	23	79
TTS 7,5/1500	*553995	7500	700 - 1500	32	98
TTS 10,0/1500	*552219	10000	700 - 1500	32	117
TTS 12,5/1500	*554008	12500	700 - 1500	40	116
TTS 15,0/1500	*554015	15000	700 - 1500	40	137
TTS 20,0/1500	*554022	20000	700 - 1500	50	180
TTS 25,0/1500	*554039	25000	700 - 1500	50	226
TTS 1,0/2500	*554046	1000	1500 - 2500	18	58
TTS 2,0/2500	*552158	2000	1500 - 2500	18	84
TTS 3,0/2500	*552448	3000	1500 - 2500	21	105
TTS 5,0/2500	*552424	5000	1500 - 2500	23	127
TTS 7,5/2500	*554053	7500	1500 - 2500	32	178
TTS 10,0/2500	*554060	10000	1500 - 2500	32	215
TTS 12,5/2500	*554077	12500	1500 - 2500	40	198
TTS 15,0/2500	*554084	15000	1500 - 2500	40	237
TTS 20,0/2500	*554091	20000	1500 - 2500	50	287
TTS 25,0/2500	*554107	25000	1500 - 2500	50	342
TTS 1,0/3500	*552684	1000	1700 - 3500	18	95
TTS 2,0/3500	*554114	2000	1700 - 3500	18	137
TTS 3,0/3500	*554121	3000	1700 - 3500	21	162
TTS 5,0/3500	*554138	5000	1700 - 3500	23	228
TTS 7,5/3500	*554145	7500	1700 - 3500	32	278
TTS 10,0/3500	*554152	10000	1700 - 3500	32	317
TTS 12,5/3500	*554169	12500	1700 - 3500	40	295
TTS 15,0/3500	*551403	15000	1700 - 3500	40	340
TTS 20,0/3500	*554176	20000	1700 - 3500	50	451
TTS 25,0/3500	*554183	25000	1700 - 3500	50	512
TTS 1,0/5000	*554367	1000	2000 - 5000	18	190
TTS 2,0/5000	*554374	2000	2000 - 5000	18	219
TTS 3,0/5000	*554381	3000	2000 - 5000	21	260
TTS 5,0/5000	*554398	5000	2000 - 5000	23	372
TTS 7,5/5000	*554404	7500	2000 - 5000	32	423
TTS 10,0/5000	*554411	10000	2000 - 5000	32	531
TTS 12,5/5000	*554428	12500	2000 - 5000	40	449
TTS 15,0/5000	*554435	15000	2000 - 5000	40	568
TTS 20,0/5000	*554442	20000	2000 - 5000	50	691
TTS 1,0/8000	*554459	1000	3000 - 8000	18	342
TTS 2,0/8000	*554466	2000	3000 - 8000	18	458
TTS 3,0/8000	*554473	3000	3000 - 8000	21	547
TTS 5,0/8000	*554480	5000	3000 - 8000	23	788
TTS 7,5/8000	*554497	7500	3000 - 8000	32	883
TTS 10,0/8000	*554503	10000	3000 - 8000	32	1319
TTS 12,5/8000	*554510	12500	3000 - 8000	40	979
TTS 15,0/8000	*554527	15000	3000 - 8000	40	1046

Dimensions model TTS

Model	TTS 1,0/1500	TTS 2,0/1500	TTS 3,0/1500	TTS 5,0/1500	TTS 7,5/1500	TTS 10,0/1500	TTS 12,5/1500	TTS 15,0/1500	TTS 20,0/1500	TTS 25,0/1500
B, mm	410	440	540	625	710	805	835	880	990	1200
C, mm	110	135	160	180	200	260	260	260	260	300
D, mm	25	30	35	40	60	70	75	85	90	100
E, mm	60	75	90	100	130	130	140	140	160	160

Model	TTS 1,0/2500	TTS 2,0/2500	TTS 3,0/2500	TTS 5,0/2500	TTS 7,5/2500	TTS 10,0/2500	TTS 12,5/2500	TTS 15,0/2500	TTS 20,0/2500	TTS 25,0/2500
B, mm	410	475	580	645	755	850	885	925	1030	1225
C, mm	110	135	160	180	200	260	260	260	260	300
D, mm	25	30	35	40	60	70	75	85	90	100
E, mm	60	75	90	100	130	130	140	140	160	160

Model	TTS 1,0/3500	TTS 2,0/3500	TTS 3,0/3500	TTS 5,0/3500	TTS 7,5/3500	TTS 10,0/3500	TTS 12,5/3500	TTS 15,0/3500	TTS 20,0/3500	TTS 25,0/3500
B, mm	410	500	605	685	780	875	905	950	1085	1270
C, mm	110	135	160	180	200	260	260	260	260	300
D, mm	25	30	35	40	60	70	75	85	90	100
E, mm	60	75	90	100	130	130	140	140	160	160

Model	TTS 1,0/5000	TTS 2,0/5000	TTS 3,0/5000	TTS 5,0/5000	TTS 7,5/5000	TTS 10,0/5000	TTS 12,5/5000	TTS 15,0/5000	TTS 20,0/5000
B, mm	465	520	625	710	800	920	950	995	1125
C, mm	110	135	160	180	200	260	260	260	260
D, mm	25	30	35	40	60	70	75	85	90
E, mm	60	75	90	100	130	130	140	140	160

Model	TTS 1,0/8000	TTS 2,0/8000	TTS 3,0/8000	TTS 5,0/8000	TTS 7,5/8000	TTS 10,0/8000	TTS 12,5/8000	TTS 15,0/8000
B, mm	485	560	670	755	865	980	1015	1055
C, mm	110	135	160	180	200	260	260	260
D, mm	25	30	35	40	60	70	75	85
E, mm	60	75	90	100	130	130	140	140

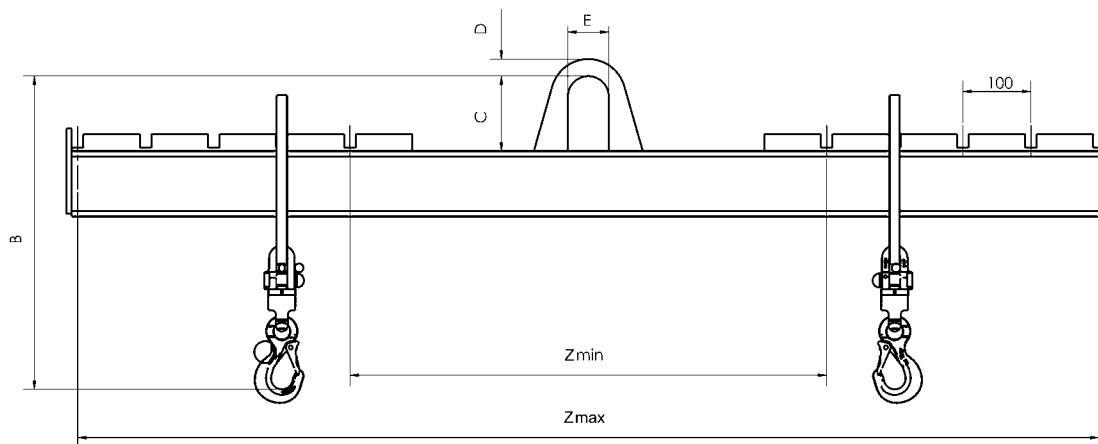

### Customized spreader beams

#### Quick overview of our extensive program

Spreader beams are required in the most different versions and designs.

The illustrations given on these pages reflect a brief overview of the multitude of various spreader beam versions.

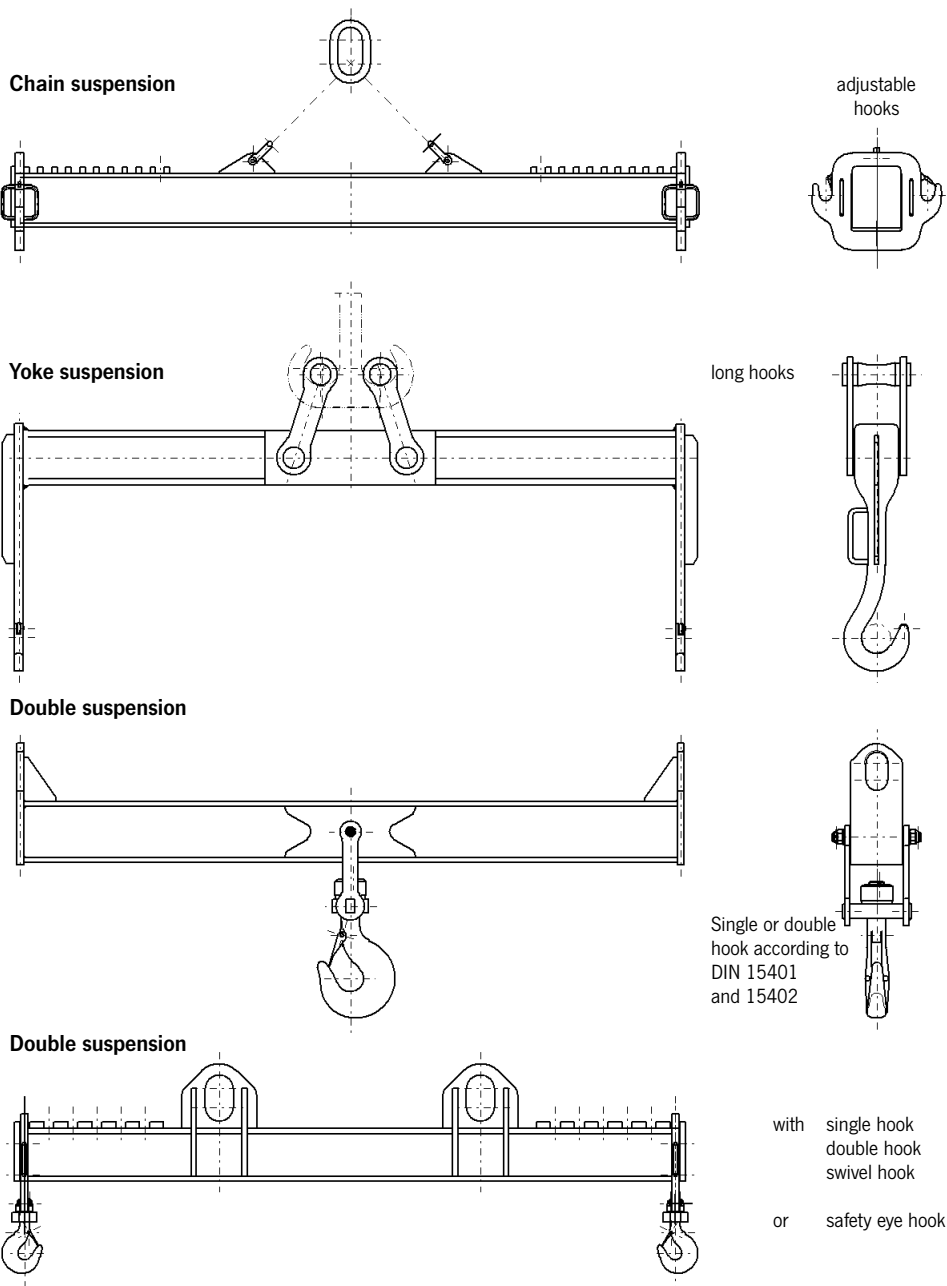

## Standard spreader beams

### Hooks with safety latch

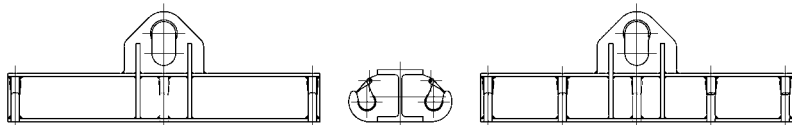

### Hooks with safety latch

adjustable

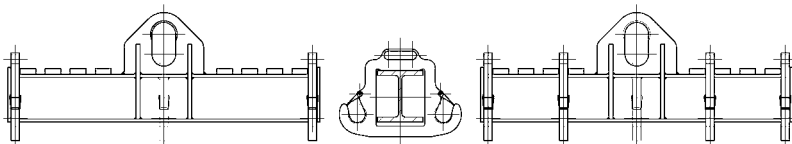

### Safety eye hooks

pivoting

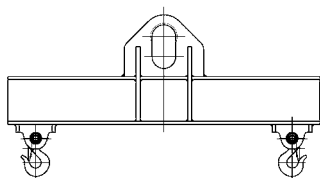

### with swivel hooks

swivelling and pivoting

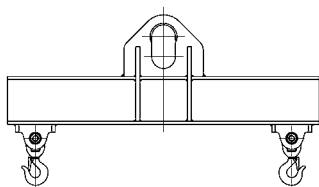

### with long hooks

fixed or adjustable

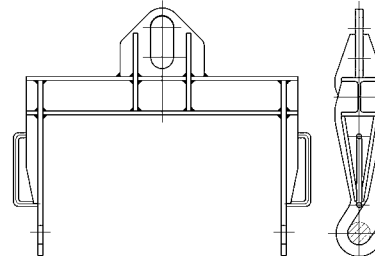

### Safety eye hooks

pivoting and adjustable

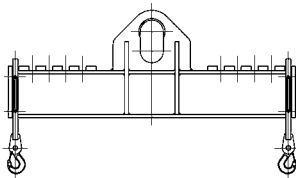

### with swivel hooks

swivelling, pivoting and adjustable

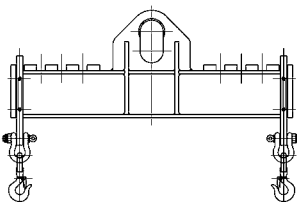

## Spreader beams with side hooks

### Safety eye hooks

pivoting

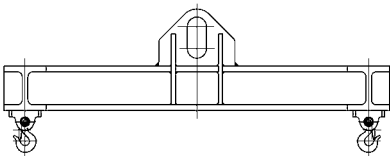

fixed

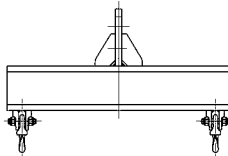

### Swivel hooks

swivelling, pivoting and adjustable

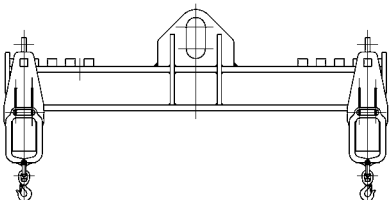

adjustable

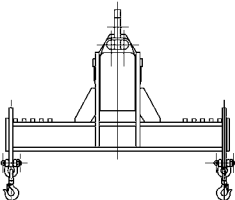





## Spreader beam for box pallets model TTS

Capacity 1000 - 3000 kg

Box pallets with DIN 15155 specifications, are usually moved around with a forklift, but are so sturdy that they can be picked up and transported with a spreader beam grab and an overhead crane hooked up to the top of the box pallet's frame.

Thanks to these spreader beams, the shipping and receiving area is no longer entirely dependent on floor-level material handling equipment such as forklifts.

The version designed for the individual transport of box pallets is equipped with two fixed yokes and two pivoted ones, interconnected with a control bar. The load tackling gear is fixed and unfixable by only one person.

**When using these spreader beams, it is important that the hooks be fastened only to the top frame of the box pallets.**

### Technical data model TTS

Model	EAN-No. 4025092*	Capacity kg	Weight kg
TTS 1,0/1240 - 810	*551595	1000	38
TTS 2,0/1240 - 810	*551236	2000	61
TTS 3,0/1240 - 810	*553742	3000	80

### Dimensions model TTS

Model	TTS 1,0/1240 - 810	TTS 2,0/1240 - 810	TTS 3,0/1240 - 810
A, mm	1175	1175	1175
B, mm	600	600	600
C, mm	410	495	520
D, mm	195	215	215
E, mm	125	180	205
F, mm	100	150	170
G, mm	80	100	130
H, mm	28	30	40
I, mm	15	20	25

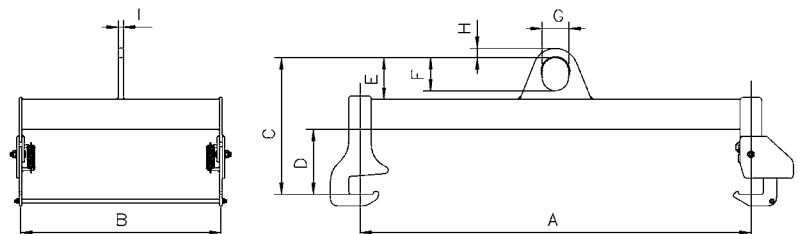

### Spreader beam for Big-Bags model TTB

Capacity 1000 - 2000 kg

This four-point spreader beam in a fixed frame construction with weld-on hooks and safety latch is designed for lifting and transporting of Big-Bags.



#### Technical data model TTB

Model	EAN-No. 4025092*	Capacity kg	Working width Z mm	Weight kg
TTB 1,0/1090 - 1090	*556293	1000	750 - 800	27
TTB 1,0/1320 - 1320	*556316	1000	900 - 970	33
TTB 2,0/1090 - 1090	*556330	2000	750 - 800	42
TTB 2,0/1320 - 1320	*556354	2000	900 - 970	44

#### Dimensions model TTB

Model	TTB 1,0/1090 - 1090	TTB 1,0/1320 - 1320	TTB 2,0/1090 - 1090	TTB 2,0/1320 - 1320
B, mm	210	210	240	240
C, mm	60	60	75	75
D, mm	110	110	135	135

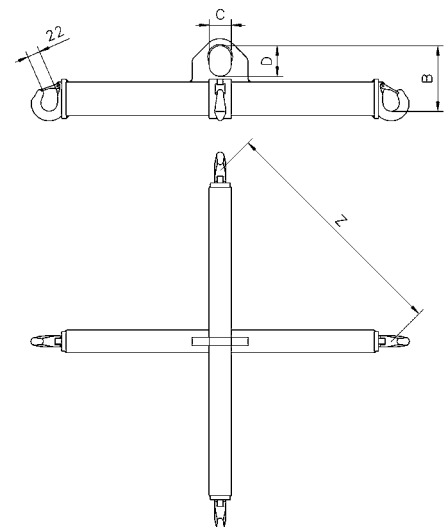



## Crane forks model TKG vhs

### Capacity 200 - 5000 kg

These crane forks are equipped with adjustable tines, height adjustability and an automatic balancing system. Crane forks with automatic balancing\* tend to point their tines upward when being transported. This prevents the load from unintentionally slipping off the tines.

The shackle is movable and runs on a track depending on the load. The automatic balancing engages by a pressurized gas spring once the forks are loaded. The load will always be in the center of gravity of the forks, ensuring a safe transport.

**\*The automatic balancing system requires a minimum load of 20% of the crane forks' working load limit.**

### Features

- All crane forks comply with the latest standards and CE-directives.
- Safety factor 4:1
- Maintenance-free
- Highly visible safety colour
- For the transport of rings or coils, the fork tines are simply pushed together.
- Easily adjustable tines for all pallet sizes.

### Scope of delivery

Chain for load securing

**!** For the transport of loads above persons (e.g. on construction sites) appropriate security measures against falling loads or parts must be taken.

**!** The load must not exceed the fork length.

### Technical data model TKG vhs

Model	EAN-No. 4025092*	Capacity kg	Weight kg
TKG 1,0 vhs	*552233	200 - 1000	128
TKG 1,5 vhs	*551113	300 - 1500	158
TKG 2,0 vhs	*550666	400 - 2000	203
TKG 3,0 vhs	*551090	600 - 3000	260
TKG 5,0 vhs	*554794	1000 - 5000	413

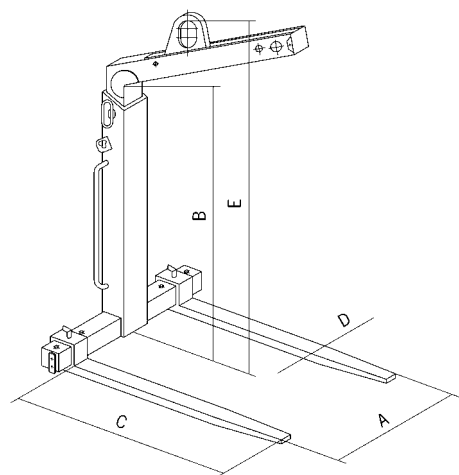

### Dimensions model TKG vhs

Model	TKG 1,0 vhs	TKG 1,5 vhs	TKG 2,0 vhs	TKG 3,0 vhs	TKG 5,0 vhs
Adjustment of tines A, mm	350 - 900	350 - 900	400 - 900	450 - 900	500 - 1000
Usable height B, mm	1100 - 1600	1300 - 2000	1300 - 2000	1300 - 2000	1300 - 2000
Length of tines C, mm	1000	1000	1000	1000	1000
Section of tines D, mm	100x30	100x40	120x40	120x50	150x60
Overall height E, mm	1420 - 1920	1650 - 2350	1655 - 2355	1720 - 2420	1710 - 2410

## Crane forks model TKG vh

Capacity 1000 - 5000 kg

These crane forks are equipped with adjustable tines and height adjustability. The balancing system engages when the shackle is manually hooked into the appropriate notch.

### Features

- All crane forks comply with the latest standards and CE-directives.
- Safety factor 4:1
- Maintenance-free
- Highly visible safety colour
- For the transport of rings or coils, the fork tines are simply pushed together.
- Easily adjustable tines for all pallet sizes.

### Scope of delivery

Chain for load securing



**The load must not exceed the fork length.**

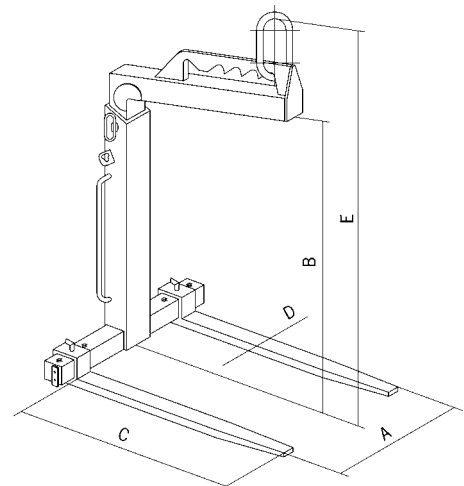

### Technical data model TKG vh

Model	EAN-No. 4025092*	Capacity kg	Weight kg
TKG 1,0 vh	*552370	1000	128
TKG 1,5 vh	*551052	1500	148
TKG 2,0 vh	*554756	2000	193
TKG 3,0 vh	*551564	3000	248
TKG 5,0 vh	*554763	5000	388

### Dimensions model TKG vh

Model	TKG 1,0 vh	TKG 1,5 vh	TKG 2,0 vh	TKG 3,0 vh	TKG 5,0 vh
Adjustment of tines A, mm	350 - 900	350 - 900	400 - 900	450 - 900	500 - 1000
Usable height B, mm	1100 - 1600	1300 - 2000	1300 - 2000	1300 - 2000	1300 - 2000
Length of tines C, mm	1000	1000	1000	1000	1000
Section of tines D, mm	100x30	100x40	120x40	120x50	150x60
Overall height E, mm	1390 - 1890	1600 - 2300	1640 - 2340	1670 - 2370	1700 - 2400



## - with digital display and radio control model TKR

The crane weigher can be operated by radio control. The displayed values can be taken off the remote control device and can be transferred to a PC. The system can be combined with an easy-to-read display. Several measured values can be totalled and saved.

### Features

- TKR crane weigher has the same features like the model TKL plus:
- Remote control and data exchange via radio transmission.
- USB interface
- Accumulation memory

### Options

- External easy-to-read display.

### Scope of delivery

- Crane weigher
- Remote control with display
- 7 x 1.5V AA batteries
- Carrying case
- Test certificate
- PC cable
- User software



## Crane weighers

### Measuring range 0 - 12 t

The crane weighers TKL and TKR are compact measuring devices for the weighing of loads. Use appropriate attachments like grade 8 forgings between the hook of the hoist or crane, the crane weigher and the load.

The crane weighers have a liquid crystal display (LCD), which can tare as well as show either the gross or the net load. It also indicates overload at 110% of the rated capacity and the status of the battery.

### - with digital display model TKL

#### Features

- High accuracy
- Lightweight design
- Easy-to-read display
- Easy to use
- Robust design
- Housing can be rotated 180°
- Retains the peak value to memory.
- The battery capacity provides for around 200 operating hours.
- Automatic setting to zero when load indicator is switched on.
- Use of rechargeable batteries possible (external battery charger\*).
- Display of maximum weight (gross/net).
- Display of measuring units at the load indicator.
- Measuring units kg, t, lbs, to, kN.
- Automatic stand-by for a prolonged battery lifetime.
- Simple change of batteries
- Warning if batteries are low.
- Overload warning

#### Scope of delivery

- Crane weigher
- 4 x 1.5V AA batteries
- Test certificate

\* not part of the delivery package.

## Technical data model TKL and model TKR

Model	TKL 1,0 TKR 1,0	TKL 2,0 TKR 2,0	TKL 3,2 TKR 3,2	TKL 5,0 TKR 5,0	TKL 8,0 TKR 8,0	TKL 12,0 TKR 12,0
EAN-No. model TKL 4025092*	*382878	*382922	*382984	*383059	*383073	*383097
EAN-No. model TKR 4025092*	*382915	*382946	*382779	*383066	*383080	*383103
Measuring range, t	0 - 1.0	0 - 2.0	0 - 3.2	0 - 5.0	0 - 8.0	0 - 12.0
Nominal load, t	1.0	2.0	3.2	5.0	8.0	12.0
Limit load, t	1.1	2.2	3.5	5.5	8.8	13.2
Breaking load, t	≥4.0	≥8.0	≥13.0	≥20.0	≥32.0	≥48.0
Weight without lifting accessories, kg	1.85	1.99	2.5	2.7	3.6	3.9
Weight with lifting accessories, kg	3.0	3.5	6.0	7.5	10.5	20.0
Accuracy of the end value	0.1%	0.1%	0.1%	0.1%	0.1%	0.1%
Resolution step, kg (partition)	0.5	1.0	1.0	1.0	2.0	5.0
Operation time, approx., h*	200					
Temperature range (operation)	-10° C up to +50° C					
Temperature range (storage)	-20° C up to +70° C					
Protection	IP 54					
Display (LCD 20.5 mm high)	4½ digits					
Tare range	100% of rated capacity					
Overload warning	Overload warning at 110% of the rated capacity					

\*with 4x 1.5V AA batteries

## Dimensions model TKL and model TKR

Model	TKL 1,0 TKR 1,0	TKL 2,0 TKR 2,0	TKL 3,2 TKR 3,2	TKL 5,0 TKR 5,0	TKL 8,0 TKR 8,0	TKL 12,0 TKR 12,0
A, mm	389	417	488	571	657	804
B, mm	356	379	441	514	588	709
C, mm	60	60	75	90	100	140
D, mm	110	110	135	160	180	260
E, mm	13	16	18	22	26	35
F, mm	20	25	32	40	49	45
G, mm	70	81	103	126	152	190
H, mm	128	136	140	148	158	176
J, mm	77.4	77.4	84.4	84.4	97.4	97.4

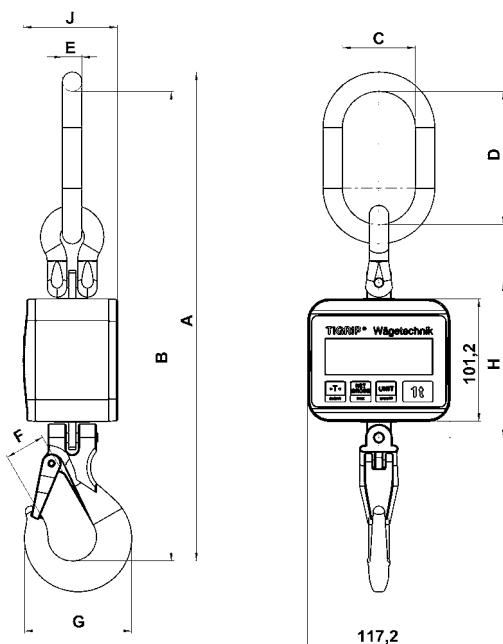





## -with digital display and radio control model TZR

The load indicator can be operated via radio control. The displayed values can be taken off the remote control device and can be transmitted to a PC. The system can be combined with an easy-to-read display. Several measured values can be totalled and saved.

### Features

- TZR load indicator has the same features like the model TZL plus:
- Remote control and data exchange via radio transmission.
- USB interface
- Accumulation memory

### Options

- External easy-to-read display.

### Scope of delivery

- Load indicator
- Remote control with display
- 7 x 1.5V AA batteries
- Test certificate
- Without shackles and hooks
- PC cable
- User software



## Load indicator

### Measuring range 0 - 100 t

The Tigrip® load indicator is a mechanical measuring instrument with electronic display. On account of its flexibility the Tigrip® load indicator has universal applications. Whether used as a conventional crane weigher or to measure forces, it is the economical choice for various applications. It can be used in conjunction with shackles and hooks.

The load indicator is provided with liquid crystal display (LCD), which can tare as well as show either the gross or the net load. It also indicates overload at 110% of the rated capacity and the status of the battery.

### - with digital display model TZL

#### Features

- High accuracy
- Lightweight design
- Easy-to-read display
- Easy to use
- Robust design
- Retains the peak value to memory.
- The battery capacity provides for around 200 operating hours.
- Automatic setting to zero when load indicator is switched on.
- Use of rechargeable batteries possible (external battery charger\*).
- Display of maximum weight (gross/net).
- Display of measuring units at the load indicator.
- Measuring units kg, t, lbs, to, kN.
- Automatic stand-by for a prolonged battery lifetime.
- Simple change of batteries
- Warning if batteries are low.
- Overload warning

#### Scope of delivery

- Load indicator
- 4 x 1.5V AA batteries
- Test certificate
- Without shackles and hooks

\* not part of the delivery package.

Technical data model TZL and model TZR

Model	TZL 1,0 TZR 1,0	TZL 2,5 TZR 2,5	TZL 5,0 TZR 5,0	TZL 10,0 TZR 10,0	TZL 20,0 TZR 20,0	- TZR 35,0	- TZR 50,0	- TZR 100,0
EAN-No. model TZL 4025092*	*262217	*262224	*262231	*256995	*262347	-	-	-
EAN-No. model TZL shackles 4025092*	*453509	*453653	*453660	*453714	*453714	-	-	-
EAN-No. model TZL hooks 4025092*	*270342	*557665	*557689	*551311	*551007	-	-	-
EAN-No. model TZR 4025092*	*262798	*266222	*272964	*257008	*272971	*455176	*455183	*455206
EAN-No. model TZR shackles 4025092*	*453509	*453653	*453660	*453714	*453714	*453738	*453745	*456746
EAN-No. model TZR hooks 4025092*	*270342	*557665	*557689	*551311	*551007	*552226	*555050	*558785
Measuring range, t	0 - 1.0	0 - 2.5	0 - 5.0	0 - 10.0	0 - 20.0	0 - 35.0	0 - 50.0	0 - 100.0
Nominal load, t	1.0	2.5	5.0	10.0	20.0	35.0	50.0	100.0
Limit load, t	1.1	2.75	5.5	11	22	38.5	55	110
Breaking load, t	≥4	≥10	≥20	≥40	≥80	≥140	≥200	≥400
Weight without lifting accessories, kg	1.1	1.7	2.1	3.9	6.8	9.4	14.4	39.3
Accuracy of the end value	0.2%	0.2%	0.2%	0.2%	0.2%	0.2%	0.2%	0.2%
Resolution step, kg (partition)	1	1	1	10	10	10	10	50
Operation time approx., h*	200							
Temperature range (operation)	-10° C up to +50° C							
Temperature range (storage)	-20° C up to +70° C							
Protection	IP 54							
Display (LCD 20.5 mm high)	4 ½ digits							
Tare range	100% of rated capacity							
Overload warning	Overload warning at 110% of the rated capacity							

\*with 4 x 1.5V AA batteries

Dimensions model TZL and model TZR

Model	TZL 1,0 TZR 1,0	TZL 2,5 TZR 2,5	TZL 5,0 TZR 5,0	TZL 10,0 TZR 10,0	TZL 20,0 TZR 20,0	- TZR 35,0	- TZR 50,0	- TZR 100,0
A, mm	190	233	250	325	378	405	450	640
B, mm	118	118	118	118	141	156	180	260
C, mm	14	22	27	48	55	66	76	100
D, mm	151	173	180	213	233	245	264	380
E, mm	12.5	19	21.5	22	32	47	55	80
F, mm	37	-	-	-	-	-	-	-
G, mm	21	25	30.5	47	57	67	77	99
H, mm	38.4	42.2	45.1	64.4	74.2	84.2	94.2	113
J, mm	348	604	610	690	780	1000	1170	-
K, mm	30	34	50	105	92	130	140	300
L, mm	26	38	44	95	95	114	132	238
M, mm	10	16	19	35	35	44	51	89
N, mm	25	25	32	50	70	110	115	-
O, mm	23	23	37	63	80	123	132	-
P, mm	17	17	28	44	57	90	97	-
Q, mm	235	309	315	535	562	665	730	1240
R, mm	16	-	-	-	-	-	-	-

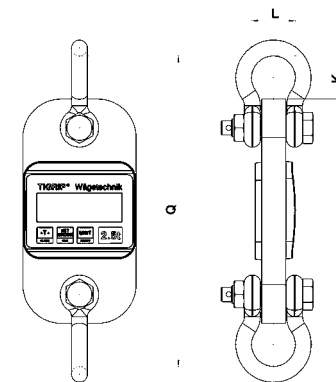

Load indicator model TZL/TZR with shackle

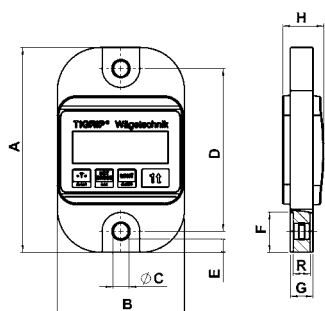

Load indicator model TZL/TZR 1,0 t

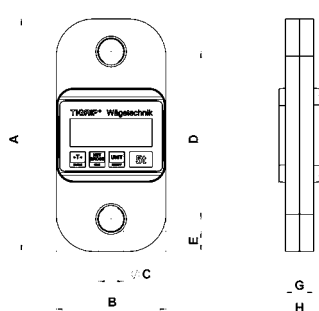

Load indicator model TZL/TZR 2,5 up to 100,0 t

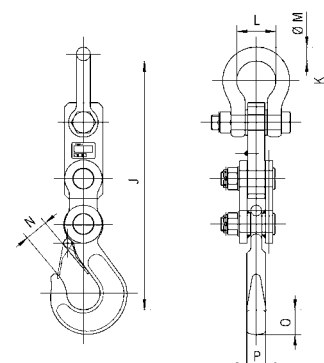

Load indicator model TZL/TZR with hook



### Spring tensioners model YFS

Capacity 0.5 - 10.0 kg

### Spring tensioners with ratchet locking device model YFS-A

Capacity 2.0 - 10.0 kg

Spring tensioners are designed to retract the cable when no force is applied. An amount of downward force must be continually applied to keep the suspended object at its extended position.

The torque output of the rewind spring increases as the cable is extended, retracting the suspended object to the uppermost adjusted position when released.

#### Features

- Stamped steel construction, powder-coated housing.
- Automatic drumlock according to DIN 15112
- Additional hanger for the attachment of secondary safety chains according to DIN 15112.
- Rope guide made of wear-resistant nylon for reduced wear of rope and body.
- Declaration of EC-conformity.
- Adjustable cable stop to fix the spring tensioner in the desired position.
- Series YFS-A with ratchet-locking device. Locks the out-retracting rope for unrestricted tool movement. This device can be switched ON/OFF, so the spring tensioner can be used with or without the ratchet-locking device.

#### Applications

Pneumatic power-tools, assembly tools, paint spraying guns, riveting machines, nut runners, grinding and polishing machines



Adjustment of spring tension Model YFS-01/02 with central turning wheel and spring lever



Adjustment of spring tension Model YFS-03/04/05 with central shaft and spring lever

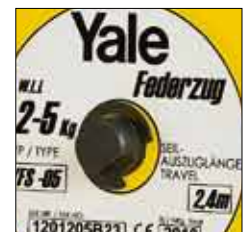

Technical data model YFS and model YFS-A

Model	EAN-No. 4025092*	Capacity min. kg	Capacity max. kg	Working range m	Weight kg
YFS-01	*514491	0.5	1.5	1.6	0.35
YFS-02	*514521	1.5	3.0	1.5	0.35
YFS-03	*514552	2.0	5.0	2.4	3.9
YFS-04	*514569	4.0	6.0	2.4	4.5
YFS-05	*514590	6.0	10.0	2.4	4.5
YFS-03-A	*514606	2.0	5.0	2.4	3.9
YFS-04-A	*514613	4.0	6.0	2.4	4.5
YFS-05-A	*514668	6.0	10.0	2.4	4.5

Dimensions model YFS and model YFS-A

Model	YFS-01	YFS-02	YFS-03	YFS-04	YFS-05	YFS-03-A	YFS-04-A	YFS-05-A
A, mm	231	231	423	423	423	423	423	423
B, mm	224	224	214	214	214	214	214	214
C, mm	97	97	191	191	191	191	191	191
Ø D, mm	12	12	19	19	19	19	19	19
E, mm	48	48	79	79	79	91	91	91
F, mm	25	25	43	43	43	55	55	55
G, mm	-	-	71	71	71	71	71	71
H, mm	39	39	80	80	80	80	80	80

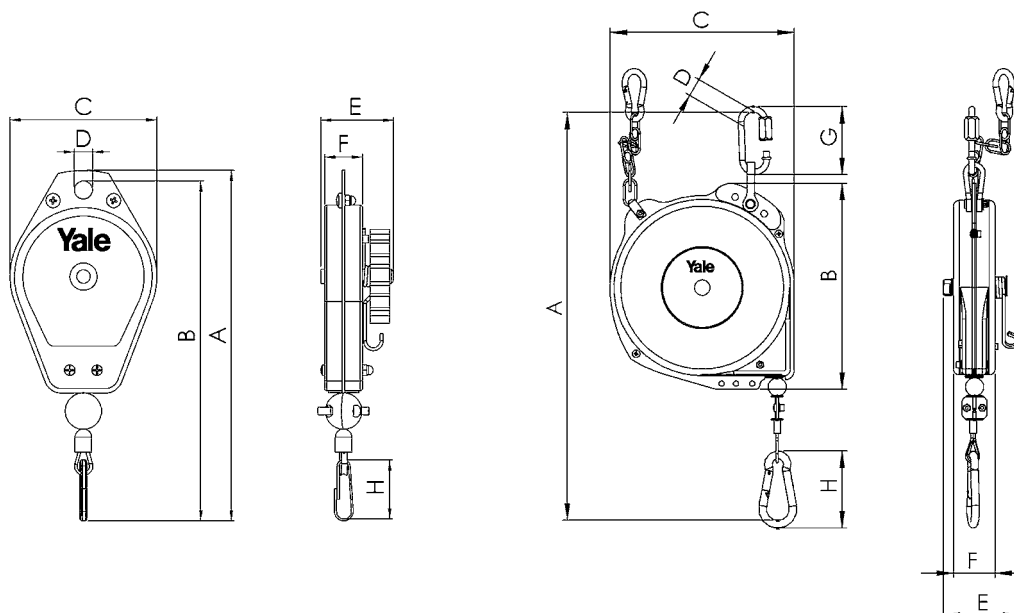



**Capacities up to 300 kg available on request.**



**Load indicator**  
for models  
YBF-09 up to YBF-70  
YBF-22L up to YBF-70L  
YBA-15 up to YBA-70  
YBA-22L up to YBA-70L



**Rope guide**  
for models  
YBF-09 up to YBF-200  
YBF-09L up to YBF-130L  
YBA-15 up to YBA-70



**Spring assembly**  
as separate unit in a closed  
steel housing.  
All models with capacities  
more than 5 kg.

## Spring balancers model YBF

Capacity 0.5 - 200 kg

## Spring balancers with extended rope length model YBF-L

Capacity 1.5 - 130 kg

Spring balancers are used to relieve the operator from the weight of hand-tools. By using a tapered rope drum the weight of the attached load is compensated, loads up to 200 kg can be moved effortlessly in vertical axis.

### Features

- Spring balancers model YBF are designed in accordance with DIN 15112
- The housing is manufactured from high-tensile aluminium pressure die casting for maximum resistance to impact.
- Manual drum lock for an easy exchange of rope or for changing the attached load.
- The special spring-assembly inside the balancer guarantees a consistent counterbalance throughout the complete working range.
- Easy exchange of wire rope. A small slot in the body facilitates the removal and re-installation of the rope without any need to disassemble the unit.
- Spring assemblies as separate units in a closed steel housing for improved handling during assembly and disassembly. Reduced risk of injuries.
- Rope guide made of wear-resistant nylon for reduced wear of rope and body. Lifetime of the spring balancer is increased. The rope guide can be removed and installed on site without disassembling the rope.
- Load indicator allows easy reading of the capacity set.
- Upper and lower suspension eyes are provided for the attachment of secondary safety chains. Providing additional safety and preventing the spring balancer and load from falling accidentally.
- Declaration of EC-conformity.

### Applications

Spot-welding guns, riveting-machines, slaughterhouse equipment, multiple nut-runners etc.

**Spring balancers with safety feature in case of rope breakage model YBA**

Capacity 9 - 70 kg

**Spring balancers with safety feature in case of rope breakage and with extended rope length model YBA-L**

Capacity 9 - 70 kg

YBA series spring balancers have the same technical features as the YBF series, but are equipped with an additional safety feature in case of rope breakage. This mechanism automatically locks the rope in case of accidental dislodging of the suspended weight, breakage of the bottom hook or the rope.

Whipping of the rope and potential injuries to the operator or other personnel in the area is avoided.

This series is used primarily in areas in which higher safety standards are applied or adverse conditions are common (flying sparks etc.) which might cause damages to the rope.

This series is available with standard and extended rope length.



**Suspension eye**  
according DIN 15112 spring balancers must be equipped with additional suspension eyes for the attachment of secondary safety chains.



**Easy exchange of wire rope**  
without any need to disassemble the unit.  
model YBF-09 up to YBF-100  
model YBA-15 up to YBA-70



**Manual drum-lock**  
for an easy exchange of the rope. All models with capacity more than 5 kg.



# Spring Balancers Spring balancers

## Technical data model YBF and model YBF-L

Model	Suspension eyes top (T) and bottom (B)	Adjustment of spring tension V=vertical H=horizontal	Tapered rope drum	Manual drum lock	Automatic drum-locking device	Load indicator	Spring assembly enclosed	Closed body	Rope guide, nylon	Rope exchange without disassembly
YBF-01	T	H	•	–	–	–	–	•	–	–
YBF-02	T	H	•	–	–	–	–	•	–	–
YBF-03	T	H	•	–	–	–	–	•	–	–
YBF-05	T	H	•	–	–	–	–	•	–	–
YBF-09	T	H	•	•	•	•	•	•	•	•
YBF-15	T	H	•	•	•	•	•	•	•	•
YBF-22	T + B	V	•	•	•	•	•	•	•	•
YBF-30	T + B	V	•	•	•	•	•	•	•	•
YBF-40	T + B	V	•	•	•	•	•	•	•	•
YBF-50	T + B	V	•	•	•	•	•	•	•	•
YBF-60	T + B	V	•	•	•	•	•	•	•	•
YBF-70	T + B	V	•	•	•	•	•	•	•	•
YBF-85	T + B	V	•	•	•	–	•	•	•	•
YBF-100	T + B	V	•	•	•	–	•	•	•	•
YBF-120	T	H	•	•	•	–	•	•	•	–
YBF-140	T	H	•	•	•	–	•	•	•	–
YBF-170	T	H	•	•	•	–	•	•	•	–
YBF-200	T	H	•	•	•	–	•	•	•	–
YBF-03L	T	H	•	–	•	–	–	•	–	–
YBF-05L	T	H	•	–	•	–	–	•	–	–
YBF-09L	T	V	•	•	•	–	•	•	•	–
YBF-15L	T	V	•	•	•	–	•	•	•	–
YBF-22L	T	V	•	•	•	•	•	•	•	–
YBF-30L	T	V	•	•	•	•	•	•	•	–
YBF-40L	T + B	V	•	•	•	•	•	•	•	–
YBF-50L	T + B	V	•	•	•	•	•	•	•	–
YBF-60L	T + B	V	•	•	•	•	•	•	•	–
YBF-70L	T + B	V	•	•	•	•	•	•	•	–
YBF-85L	T + B	V	•	•	•	–	•	•	•	–
YBF-100L	T	H	•	•	•	–	•	•	•	–
YBF-120L	T	H	•	•	•	–	•	•	•	–
YBF-130L	T	H	•	•	•	–	•	•	•	–

## Technical data model YBA and model YBA-L

Model	Suspension eyes top (T) and bottom (B)	Adjustment of spring tension V=vertical H=horizontal	Tapered rope drum	Manual drum lock	Automatic drum-locking device	Load indicator	Spring assembly enclosed	Closed body	Rope guide, nylon	Rope exchange without disassembly
YBA-15	T	V	•	•	•	•	•	•	•	•
YBA-22	T + B	V	•	•	•	•	•	•	•	•
YBA-30	T + B	V	•	•	•	•	•	•	•	•
YBA-40	T + B	V	•	•	•	•	•	•	•	•
YBA-50	T + B	V	•	•	•	•	•	•	•	•
YBA-60	T + B	V	•	•	•	•	•	•	•	•
YBA-70	T + B	V	•	•	•	•	•	•	•	•
YBA-15L	T + B	V	•	•	•	–	•	•	•	–
YBA-22L	T + B	V	•	•	•	•	•	•	•	–
YBA-30L	T + B	V	•	•	•	•	•	•	•	–
YBA-40L	T + B	V	•	•	•	•	•	•	•	–
YBA-50L	T + B	V	•	•	•	•	•	•	•	–
YBA-60L	T + B	V	•	•	•	•	•	•	•	–
YBA-70L	T + B	V	•	•	•	•	•	•	•	–

Technical data model YBF and model YBF-L

Model	EAN-No. 4025092*	Capacity min.	Capacity max.	Working range	Weight with rope kg
		kg	kg	m	
YBF-01	*485654	0.5	1.5	1.0	1.0
YBF-02	*485661	1	2	1.0	1.0
YBF-03	*485685	1.5	3	1.3	1.8
YBF-05	*485692	3	5	1.3	1.9
YBF-09	*485777	4.5	9	1.3	4.0
YBF-15	*485784	9	15	1.3	4.0
YBF-22	*485791	15	22	1.5	8.0
YBF-30	*485807	22	30	1.5	8.0
YBF-40	*485814	30	40	1.5	10.5
YBF-50	*485821	40	50	1.5	10.5
YBF-60	*485838	50	60	1.5	11.0
YBF-70	*485845	60	70	1.5	11.5
YBF-85	*485968	70	85	1.5	12.0
YBF-100	*485975	85	100	1.5	12.5
YBF-120	*485999	100	120	1.5	28.0
YBF-140	*485982	120	140	1.5	29.0
YBF-170	*486002	140	170	1.5	35.0
YBF-200	*486019	170	200	1.5	36.0
YBF-03L	*485708	1.5	3	2.5	3.9
YBF-05L	*485753	3	5	2.5	4.0
YBF-09L	*486026	4.5	9	2.3	7.0
YBF-15L	*486033	9	15	2.3	7.5
YBF-22L	*486040	15	22	2.3	8.5
YBF-30L	*486057	22	30	2.3	8.5
YBF-40L	*486064	30	40	2.3	11.0
YBF-50L	*486071	40	50	2.3	11.0
YBF-60L	*486088	50	60	2.3	11.5
YBF-70L	*486095	60	70	2.3	12.0
YBF-85L	*486101	70	85	2.5	26.5
YBF-100L	*486217	85	100	2.5	27.0
YBF-120L	*486231	100	120	2.5	34.0
YBF-130L	*486255	120	130	2.5	35.0



Technical data model YBA and model YBA-L

Model	EAN-No. 4025092*	Capacity min.	Capacity max.	Working range	Weight with rope kg
		kg	kg	m	
YBA-15	*486279	9	15	1.3	5.5
YBA-22	*486286	15	22	1.5	8.5
YBA-30	*486293	22	30	1.5	9.0
YBA-40	*486309	30	40	1.5	11.5
YBA-50	*486316	40	50	1.5	12.0
YBA-60	*486330	50	60	1.5	13.0
YBA-70	*486323	60	70	1.5	13.5
YBA-15L	*486347	9	15	2.3	8.5
YBA-22L	*486354	15	22	2.3	9.0
YBA-30L	*486361	22	30	2.3	9.5
YBA-40L	*486378	30	40	2.3	12.0
YBA-50L	*486385	40	50	2.3	12.5
YBA-60L	*486392	50	60	2.3	13.5
YBA-70L	*486408	60	70	2.3	14.0

## Dimensions spring balancers body type I, body type II & body type III

Model	Body type I		Body type II			Body type III					
	YBF-01 YBF-02	YBF-03 YBF-05	YBF-09 YBF-15	YBF-03L YBF-05L	YBA-15	YBF-22 YBF-30	YBF-40 YBF-50	YBF-60 YBF-70 YBF-85 YBF-100	YBF-09L YBF-15L YBF-22L YBF-30L	YBF-40L YBF-50L	YBF-60L YBF-70L
A min., mm	315	290	340	375	340	445	440	440	445	440	440
A max., mm	1315	1590	1640	2875	1640	1945	1940	1940	2745	2740	2740
B, mm	132	148	174	197	174	218	220	220	218	220	220
C, mm	72	89	109	114	109	130	130	130	130	130	130
D, mm	68	78	95	105	95	111	111	111	111	111	111
E, mm	120	120	152	175	152	194	194	194	194	194	194
F, mm	22	25	15	23	15	35	35	35	35	35	35
G, mm	26	33	38	30	38	47	47	47	47	47	47
H, mm	10	10	12	12	12	15	17	17	15	17	17
I, mm	14	14	24	14	24	30	30	30	30	30	30
J, mm	9	9	14	14	14	18	18	18	18	18	18
K, mm	10	8	15	14	15	18	18	18	18	18	18
L, mm	17	14	18	17	18	24	24	24	24	24	24
M min., mm	45	45	39	65	39	46	46	46	46	46	46
M max., mm	65	75	68	105	68	83	83	83	83	83	83
N, mm	9	9	14	14	14	16	16	16	16	16	16
O, mm	6	6	9	8	9	12	14	14	12	14	14
P, mm	11	12	24	30	24	35	75	86	35	75	86
Q, mm	5	9	25	9	25	30	33	33	30	33	33
R, mm	30	32	72	45	94	80	105	116	80	105	116
S min., mm	20	35	65	55	87	72	97	97	72	97	97
S max., mm	38	50	99	85	121	112	137	137	112	137	137
T, mm	49	69	136	110	148	158	188	199	158	188	199
U, mm	-	-	-	-	-	130	130	130	130	130	130

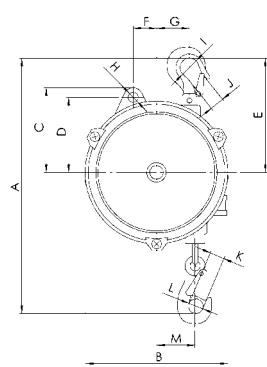

Body type I

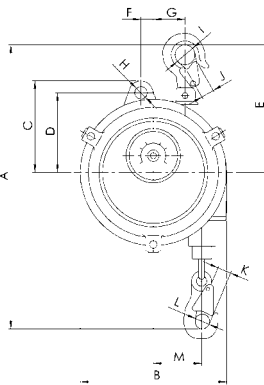
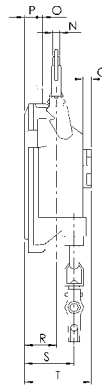

Body type II

Dimensions spring balancers body type IV & body type V

Model	Body type IV				Body type V					
	YBF-120 YBF-140	YBF-170 YBF-200	YBF-85L YBF-100L	YBF-120L YBF-130L	YBA-22 YBA-30	YBA-40 YBA-50	YBA-60 YBA-70	YBA-15L YBA-22L YBA-30L	YBA-40L YBA-50L	YBA-60L YBA-70L
A min., mm	550	550	550	550	445	440	440	445	440	440
A max., mm	2050	2050	3050	3050	1945	1940	1940	2745	2740	2740
B, mm	247	247	247	247	218	220	220	218	220	220
C, mm	156	156	156	156	130	130	130	130	130	130
D, mm	128	128	128	128	111	111	111	111	111	111
E, mm	265	265	265	265	194	194	194	194	194	194
F, mm	40	40	40	40	35	35	35	35	35	35
G, mm	65	65	65	65	47	47	47	47	47	47
H, mm	17	17	17	17	15	17	17	15	17	17
I, mm	26	26	26	26	30	30	30	30	30	30
J, mm	15	15	15	15	18	18	18	18	18	18
K, mm	24	24	24	24	18	18	18	18	18	18
L, mm	27	27	27	27	24	24	24	24	24	24
M min., mm	54	54	54	54	46	46	46	46	46	46
M max., mm	95	95	95	95	83	83	83	83	83	83
N, mm	18	18	18	18	16	16	16	16	16	16
O, mm	16	16	16	16	12	14	14	12	14	14
P, mm	142	185	142	185	55	95	105	55	95	105
Q, mm	37	37	37	37	30	33	33	30	33	33
R, mm	155	193	155	193	115	140	140	115	140	140
S min., mm	175	215	175	215	107	132	132	107	132	132
S max., mm	205	248	205	248	147	172	172	147	172	172
T, mm	268	268	268	310	180	208	218	180	208	218
U, mm	156	156	156	156	130	130	130	130	130	130

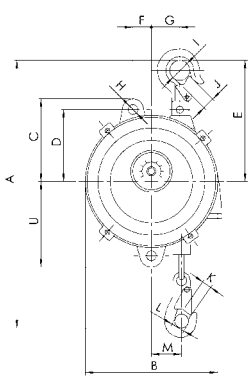

Body type III  
Body type V

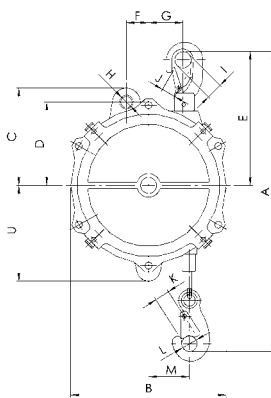
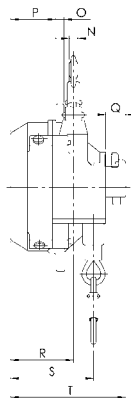

Body type IV

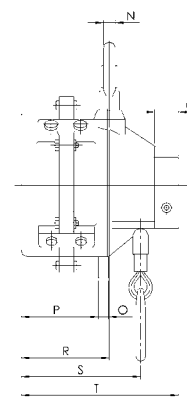

**!** Yale hoists and trolleys are not designed for passenger elevation applications and must not be used for this purpose.



Webbing slings



Round slings



Accessories



Lashing systems



Special lashings

 Please note our user instructions at the beginning of each chapter.

## Textile Lifting Slings

Yale webbing slings and round slings are produced from high-tensile quality polyester (PES) in accordance with DIN EN 1492, parts 1 and 2. The highly flexible and versatile material exerts evenly distributed pressure on pressure-sensitive and tension-sensitive loads; it is not subject to material ageing or brittleness and is heat-resistant up to +100° C.

## Lashing Systems

Yale lashing belts are produced from polyester (PES) according to DIN EN 12195-2. The extremely resilient belt material is resistant to stretching and abrasion; it guarantees a high load bearing capacity and a long service life. All Yale lashing belts are stretched belts, thermally fixed and protected against abrasion.

## Personal Protective Equipment

Yale personal protective equipment are produced in accordance with the valid directives and standards. They ensure a high degree of safety, when they are used appropriately. With its long service life the personal protective equipment helps to avoid damage to property and personal injury.



**Harnesses**

## Table of Contents

	Page
<b>Round slings</b>	236 - 238
<b>Round sling assembly</b>	239 - 241
<b>Webbing slings</b>	242 - 245
<b>Textile lifting slings accessories</b>	246 - 249
<b>Textile lashing</b>	254 - 261
<b>Special textile lashings</b>	262 - 263
<b>Lashing systems accessories</b>	264 - 267
<b>Harnesses</b>	270 - 273
<b>Lanyards</b>	274 - 276
<b>Fall arrest blocks</b>	277
<b>Tripod &amp; Winch &amp; Accessories</b>	278
<b>Fall arrester with rope grab</b>	279
<b>Height safety kits</b>	280 - 283



**This user information presents a general overview regarding the application of textile lifting slings and does not substitute the existing operating instructions for specific products!**

**Lifting operations with textile slings may be carried out by competent users (trained in theory and practice) only.**

**When operated correctly, our textile slings offer the highest degree of safety in line with long life expectancy and avoid damage to products and people.**

## Limitations of use

### Loading

Textile lifting slings must not be overloaded. The capacities for the most important lifting/sliding methods are indicated on the identity label. Always observe the maximum angle from the vertical (angle  $\beta$ )!

### Temperature

Textile lifting slings made from polyester are admitted for applications at temperatures between  $-40^{\circ}$  and  $+100^{\circ}$  C. This temperature area may change in chemical environments. The woven structure of the drenched textiles at temperatures below  $0^{\circ}$  C are susceptible to damage due to the formation of ice.

Ice will reduce the flexibility of the lifting sling! At temperatures below  $0^{\circ}$  C, dry lifting equipment should be used only! In dry condition, polyester features a high electrical resistance and provides an insulating effect between load and crane hook (e.g. during welding jobs – observe temperatures!).

### Shock loading

Textile lifting and lashing equipment should not be subjected to sharp jerks and jolts in order to avoid heavy forces which may be considerably higher than the actual load weight!

### Chemicals

Particular caution is required when using textile lifting equipment in areas where chemicals are present. Polyester has good resistance against mineral acids but will be destroyed by alkaline – consult our experts for advice in your specific application!

Acid may cause material brittleness to steel fittings of textile lifting slings! Harmless acid solutions may concentrate by evaporation to an extent that they provoke damages. Affected textile lifting equipment must be thoroughly rinsed in cold water, dried in open air and inspected by a competent person.

### Transport of people

Transport of people with textile lifting equipment is generally forbidden!

### Operation in danger zones

Lifting or transport of loads must be avoided while personnel are in the danger zone.

People are not allowed to pass over or under a suspended load!

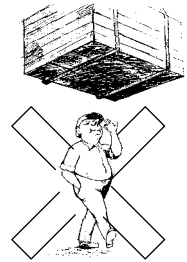

### Application advices

- The operator may start moving the load only after it has been correctly attached and all personnel are clear of the danger zone.
- Loads must not be left unattended in raised or tensioned condition for a longer period of time.
- Flat webbing or round slings must not be used in knotted, tied or twisted condition and may only be used for the attachment of loads.
- Prior to every use, textile lifting and lashing equipment must be examined with regard to obvious defects. Ensure that their identity and dimensions are correct and that they are provided with a legible capacity label. Never use lifting equipment which is defective or not labelled!
- Damage of the capacity label can be avoided by keeping it away from the load, the hook or choke hitch operations!

- The angle of the eye must not exceed  $20^{\circ}$  in order to avoid inadmissible strain on the seams! This will be ensured when the eye length is approx. 4 times the width of the hook.

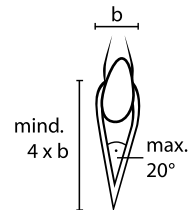

- Hooks or other lifting devices in loaded condition must not be attached in the area of sewn overlaps or at the seam of the round sling sleeve. Make sure that the seams are positioned in the straight part of the lifting device!

**! For information on training please see page 4-5.**

- Hooks should be provided with sufficient radius. The contact area of the web sling must be straight, so that the entire cross section of the sling is loaded equally. If the carrying width of flat webbing sling is below 75 mm, the radius curve of the lifting device must be at least  $\frac{3}{4}$  of the width of the webbing sling.

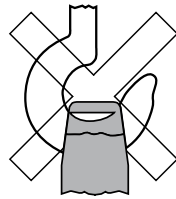

- Take care that round slings do not overlap in the crane hook. They must have sufficient space in the hook mouth as well as at the load, so they can assume their natural, flattened profile and provide even loading over the full width of the round sling.
- Flat webbing slings should be applied in such a way that they can carry the load over the full sling width. Greater angles from the vertical will strain the edges of the slings and possibly lead to breakage!
- Textile lashing equipment must be protected against sharp edges, friction and abrasion at both load and lifting device. A radius edge is classed as sharp, if it is less than the thickness of the flat webbing or round sling (in flat, loaded condition).
- Never push or place the load onto the lifting device! Never pull the load over rough surfaces or edges and do not drag from underneath a load!
- In "choke hitch" the textile sling should be positioned so that it can form a natural angle of  $60^\circ$  and that heat due to friction is avoided. Never re-adjust the choke hitch and prevent heat development by friction (slipping of load). In order to lift loads with plain or slippery surface we recommend double choke hitch.

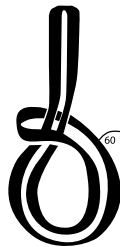

- Round slings and flat webbing slings will stretch under load by approx. 3-5%. This has to be strictly considered as it may cause abrasion resp. damages at sensible surfaces. As prevention we recommend the use of protective sleeves and edge protectors. In case of (intended) load movements during lifting operations and resulting friction, e.g. during assembling or turning of goods, the surface or edges of the load must be secured by protective sleeves or corner protectors, which will safeguard the lashing device and leave sufficient space for movement and alignment without greater friction (see dim. B in the following drawing).

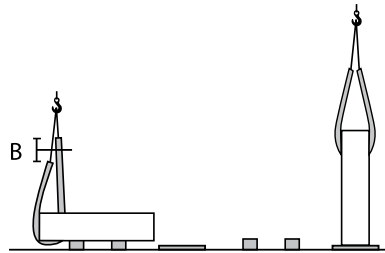

- If more than one sling is used to lift a load, these should be of same type with preferably same length in order to avoid different elongation behaviour and allow carrying ability over the full width (employ smallest angle from the vertical or use spreader beam instead).
- Textile lifting equipment must be stored in a clean, dry and well ventilated area. Avoid exposure to direct sunlight and other sources of UV. Keep them away from other heat sources, chemicals, fumes and corroded surfaces as they will have a negative effect on the life expectancy of the sling. Slings should not be dried near open fires or other hot places.
- Textile slings with obvious damages, overloading or other detrimental influences must be taken out of use and may be returned to service after inspection and possible repair only.

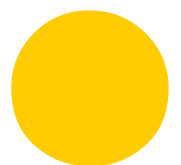

## Maintenance and repair

Inspections and tests must be performed by competent persons or specialist workshops only.

## Inspections

Depending on application, textile lifting equipment must be subjected to regular inspections by competent persons, at least once per year. The inspection must be visual and extended to the following deficiencies:

- Complete and legible identity label.
- Damages by chemical influence, e.g. local soaking, chipping of yarns or heat (hardening).
- Steel links must not show deformations, grooves or reduction to the cross section of more than 10%. Check for cracks; possible welding points must be visible and not covered by the webbing.
- Inspections have to be recorded.
- Defective slings have to be taken out of service immediately and must be stored separately.

## Criteria for disposal

**Textile slings must not be used any longer if e.g.:**

- the marking (identity label) is missing or illegible.
- detrimental impacts have occurred, e.g. overloading, shock loading, chemical influence or heat.

**Flat webbing slings:**

- damages of selvage, defects of the woven structure by abrasion, cuts or yarn breakages have occurred. If 10 % or more of the webbing sling cross section is damaged the sling must be discarded.
- heavy deformation or melting of yarns due to heat (shiny surface and/or hardened webbing) can be recognized.
- load bearing seams are defective.

**Round Slings:**

- the outside (sleeve) is damaged by cuts or abrasion.
- the inside (polyester yarns) of the sling is visible.
- the seams of the sleeve are damaged.

**!** Yale hoists and trolleys are not designed for passenger elevation applications and must not be used for this purpose.

Webbing slings Rated capacities for different slinging methods

Factor		WLL (kg) with one webbing sling					WLL (kg) with two webbing slings			
		straight pull	choke hitch	basket angle $\beta$			straight angle $\beta$		choke hitch angle $\beta$	
				bis 7°	7°-45°	45°-60°	7°-45°	45°-60°	7°-45°	45°-60°
		1.0	0.8	2.0	1.4	1.0	1.4	1.0	1.12	0.8
1000 kg		1000	800	2000	1400	1000	1400	1000	1120	800
2000 kg		2000	1600	4000	2800	2000	2800	2000	2240	1600
3000 kg		3000	2400	6000	4200	3000	4200	3000	3360	2400
4000 kg		4000	3200	8000	5600	4000	5600	4000	4480	3200
5000 kg		5000	4000	10000	7000	5000	7000	5000	5600	4000
6000 kg		6000	4800	12000	8400	6000	8400	6000	6720	4800
8000 kg		8000	6400	16000	11200	8000	11200	8000	8960	6400
10000 kg		10000	8000	20000	14000	10000	14000	10000	11200	8000

Round slings Rated capacities for different slinging methods

Factor		WLL (kg) with one round sling					WLL (kg) with two round slings					
		straight pull	choke hitch	basket angle $\beta$			straight angle $\beta$		choke hitch angle $\beta$			
				bis 7°	7°-45°	45°-60°	7°-45°	45°-60°	7°-45°	45°-60°		
		1.0	0.8	2.0	1.4	1.0	0.7	0.5	1.4	1.0	1.12	0.8
1000 kg		1000	800	2000	1400	1000	700	500	1400	1000	1120	800
2000 kg		2000	1600	4000	2800	2000	1400	1000	2800	2000	2240	1600
3000 kg		3000	2400	6000	4200	3000	2100	1500	4200	3000	3360	2400
4000 kg		4000	3200	8000	5600	4000	2800	2000	5600	4000	4480	3200
5000 kg		5000	4000	10000	7000	5000	3500	2500	7000	5000	5600	4000
6000 kg		6000	4800	12000	8400	6000	4200	3000	8400	6000	6720	4800
8000 kg		8000	6400	16000	11200	8000	5600	4000	11200	8000	8960	6400
10000 kg		10000	8000	20000	14000	10000	7000	5000	14000	10000	11200	8000



## Round sling with duplex sleeve model RSD

Made from polyester (PES), EN 1492-2 with double stitch-less protection sleeve, with capacity label.

### Features

- With double protection sleeve, PU-starched, thermally fixed.
- Colour coding of the protective sleeve.
- Printed-on capacities.
- Woven tonnage stripes, per ton capacity 1 stripe (applies only to round slings up to 10 t).
- Low weight allows easy handling.
- Protection against hand injuries.
- Protection against cargo surface damage.
- Highly flexible and adaptable to given shapes.
- UV-resistant, eliminating material ageing or embrittlement.
- Heat resistant up to +100° C.
- Moisture-resistant fabric, thus preventing frost damage (up to approx. -40° C).

**Increased capacities on request.**



### Technical data model RSD

Model	Colour code EN 1492	Capacity WLL, with one sling, straight pull kg	Capacity WLL, with one sling, basket, angle $\beta$ up to 7° kg	Capacity WLL, with one sling, basket, angle $\beta$ 7°- 45° kg	Capacity WLL, with one sling, basket, angle $\beta$ 45°- 60° kg	Capacity WLL, with one sling, choke hitch kg	Width approx. under load mm	Thickness approx. under load mm	Shortest possible length for special makes mm
RSD-01000	violet	1000	2000	1400	1000	800	52	5	500
RSD-02000	green	2000	4000	2800	2000	1600	57	6	500
RSD-03000	yellow	3000	6000	4200	3000	2400	71	9	500
RSD-04000	grey	4000	8000	5600	4000	3200	76	9	1000

**Special lengths available on request.**

## XL-Round sling model RSX

Made from polyester (PES), EN 1492-2 with extra strong stitchless protection sleeve, with capacity label.

### Features

- Optimized woven structure, PU-starched, thermally fixed.
- Easy identification of the annually required UVV tests through an additional label showing a check list.
- Colour coding of the protective sleeve.
- Printed-on capacities.
- Woven tonnage stripes, per ton capacity 1 stripe (applies only to round slings up to 10 t).
- Low weight allows easy handling.
- Protection against hand injuries.
- Protection against cargo surface damage.
- Highly flexible and adaptable to given shapes.
- UV-resistant, eliminating material ageing or embrittlement.
- Heat resistant up to +100° C.
- Moisture-resistant fabric, thus preventing frost damage (up to approx. -40° C).



**!** Further capacities up to 100 t and special lengths can be delivered on request.

### Technical data model RSX

Model	Colour code EN 1492	Capacity WLL, with one sling, straight pull kg	Capacity WLL, with one sling, basket, angle $\beta$ up to 7° kg	Capacity WLL, with one sling, basket, angle $\beta$ 7°- 45° kg	Capacity WLL, with one sling, basket, angle $\beta$ 45°- 60° kg	Capacity WLL, with one sling, choke hitch kg	Width approx. under load mm	Thickness approx. under load mm	Shortest possible length for special makes mm
RSX-01000	violet	1000	2000	1400	1000	800	52	10	500
RSX-02000	green	2000	4000	2800	2000	1600	57	10	500
RSX-03000	yellow	3000	6000	4200	3000	2400	71	15	500
RSX-04000	grey	4000	8000	5600	4000	3200	76	15	1000
RSX-05000	red	5000	10000	7000	5000	4000	86	20	1000
RSX-06000	brown	6000	12000	8400	6000	4800	96	20	2000
RSX-08000	blue	8000	16000	11200	8000	6400	112	25	2000
RSX-10000	orange	10000	20000	14000	10000	8000	130	30	2000





## Round sling with single sleeve model RSE

Made from polyester (PES), EN 1492-2 with stitchless protection sleeve, with capacity label.

### Features

- With single sleeve, PU-starched, thermally fixed.
- Colour coding of the protective sleeve.
- Printed-on capacities.
- Woven tonnage stripes, per ton capacity 1 stripe (applies only to round slings up to 10 t).
- Low weight allows easy handling.
- Protection against hand injuries.
- Protection against cargo surface damage.
- Highly flexible and adaptable to given shapes.
- UV-resistant, eliminating material ageing or embrittlement.
- Heat resistant up to +100°C.
- Moisture-resistant fabric, thus preventing frost damage (up to approx. -40°C).

**Special lengths available on request.**

### Technical data model RSE

Model	Colour code EN 1492	Capacity WLL, with one sling, straight pull kg	Capacity WLL, with one sling, basket, angle $\beta$ up to 7° kg	Capacity WLL, with one sling, basket, angle $\beta$ 7°- 45° kg	Capacity WLL, with one sling, basket, angle $\beta$ 45°- 60° kg	Capacity WLL, with one sling, choke hitch kg	Width approx. under load mm	Thickness approx. under load mm	Shortest possible length for special makes mm
RSE-01000	violet	1000	2000	1400	1000	800	50	10	500
RSE-02000	green	2000	4000	2800	2000	1600	55	10	500
RSE-03000	yellow	3000	6000	4200	3000	2400	60	15	500
RSE-04000	grey	4000	8000	5600	4000	3200	75	15	1000
RSE-05000	red	5000	10000	7000	5000	4000	85	20	1000
RSE-06000	brown	6000	12000	8400	6000	4800	90	20	2000
RSE-08000	blue	8000	16000	11200	8000	6400	100	25	2000
RSE-10000	orange	10000	20000	14000	10000	8000	120	30	2000

## 20 RSE - Round slings, EN 1492-2

with different working loads and lengths.

With each sport bag you receive:

2 x RSE 01000, WLL 1000 kg, 0.5 m length

4 x RSE 01000, WLL 1000 kg, 1.0 m length

2 x RSE 01000, WLL 1000 kg, 1.5 m length

4 x RSE 01000, WLL 1000 kg, 2.0 m, length

2 x RSE 02000, WLL 2000 kg, 1.0 m length

2 x RSE 02000, WLL 2000 kg, 2.0 m length

2 x RSE 02000, WLL 2000 kg, 3.0 m length

2 x RSE 03000, WLL 3000 kg, 2.0 m length



EAN-No.: 4025092360555

Minimum purchase: 3 bags



*Including sports bag*

## Round sling assembly Rated capacities for different slinging methods

	single legged		double legged				three and four legged	
	straight pull	choke hitch	straight pull angle $\beta$ 0°-45°	choke hitch	straight pull angle $\beta$ 45°-60°	choke hitch	straight pull angle $\beta$ 0°-45°   45°-60°	
Factor	1.0	0.8	1.4	1.1	1.0	0.8	2.1	1.5
1000 kg	1000	800	1400	1100	1000	800	2100	1500
2000 kg	2000	1600	2800	2200	2000	1600	4200	3000
3000 kg	3000	2400	4200	3300	3000	2400	6300	4500
5000 kg	5000	4000	7000	5500	5000	4000	10500	7500
8000 kg	8000	6400	11200	8800	8000	6400	16800	12000

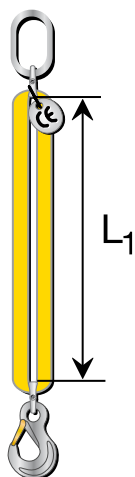

### Round sling assembly single legged model RSG

EN 1492-2 with high tensile forgings EN 1677.

#### Technical data model RSG single legged

Model	Capacity WLL straight pull kg
RSG-01000-1-SIKA	1000
RSG-02000-1-SIKA	2000
RSG-03000-1-SIKA	3000
RSG-05000-1-SIKA	5000
RSG-08000-1-SIKA	8000

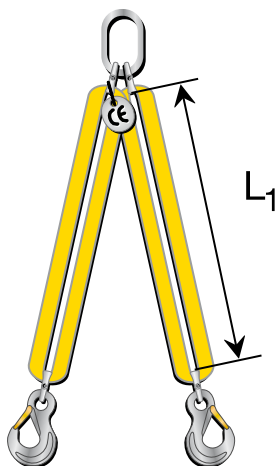

### Round sling assembly double legged model RSG

EN 1492-2 with high tensile forgings EN 1677.

#### Technical data model RSG double legged

Model	Capacity WLL, straight pull angle $\beta$ 0°-45° kg	Capacity WLL, straight pull angle $\beta$ 45°-60° kg
RSG-01000-2-SIKA	1400	1000
RSG-02000-2-SIKA	2800	2000
RSG-03000-2-SIKA	4200	3000
RSG-05000-2-SIKA	7000	5000
RSG-08000-2-SIKA	11200	8000

Round sling assembly  
three legged  
model RSG

EN 1492-2 with high tensile forgings EN 1677.

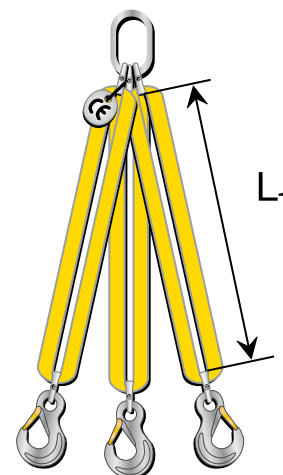

Technical data model RSG three legged

Model	Capacity WLL, straight pull angle $\beta$ 0°-45° kg	Capacity WLL, straight pull angle $\beta$ 45°-60° kg
RSG-01000-3-SIKA	2100	1500
RSG-02000-3-SIKA	4200	3000
RSG-03000-3-SIKA	6300	4500
RSG-05000-3-SIKA	10500	7500
RSG-08000-3-SIKA	16800	12000

Round sling assembly  
four legged  
model RSG

EN 1492-2 with high tensile forgings EN 1677.

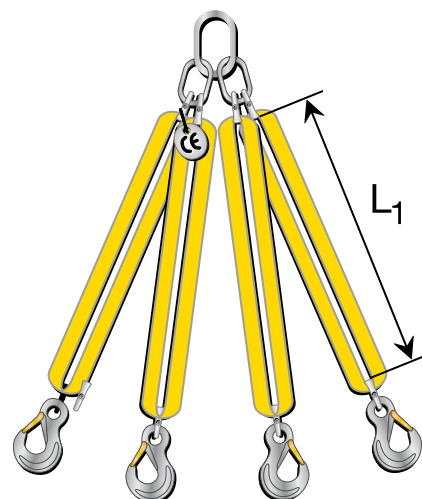

Technical data model RSG four legged

Model	Capacity WLL, straight pull angle $\beta$ 0°-45° kg	Capacity WLL, straight pull angle $\beta$ 45°-60° kg
RSG-01000-4-SIKA	2100	1500
RSG-02000-4-SIKA	4200	3000
RSG-03000-4-SIKA	6300	4500
RSG-05000-4-SIKA	10500	7500
RSG-08000-4-SIKA	16800	12000



## Endless flat webbing sling, single ply model HSE

Made from polyester (PES), EN 1492-1 form A2, with capacity label.

Other capacities up to 20 t and special lengths available on request.



### Features

- Heat resistant up to +100° C.
- Moisture-resistant fabric, thus preventing frost damage (up to approx. -40° C).
- Low elongation (<4%).
- Single ply, PU-starched, thermally fixed.
- Colour coded webbing (only model HSE).
- Woven tonnage stripes (only model HSE).
- Low weight allows easy handling.
- Protection against hand injuries.
- Protection against cargo surface damage.
- Consistent pressure distribution onto pressure- and pull sensitive loads.
- UV-resistant, eliminating material ageing or embrittlement.

### Technical data model HSE

Model	Colour code EN 1492	Capacity WLL, with one sling, straight pull kg	Capacity WLL, with one sling, basket, angle $\beta$ up to 7° kg	Capacity WLL, with one sling, basket, angle $\beta$ 7°- 45° kg	Capacity WLL, with one sling, basket, angle $\beta$ 45°- 60° kg	Capacity WLL, with one sling, choke hitch kg	Webbing width mm	Shortest possible length for special makes mm
HSE-01000	violet	1000	2000	1400	1000	800	30	500
HSE-02000	green	2000	4000	2800	2000	1600	60	500
HSE-03000	yellow	3000	6000	4200	3000	2400	90	500
HSE-04000	grey	4000	8000	5600	4000	3200	120	1000

## Endless flat webbing sling, single ply, one-way model HSE-E

Made from polyester (PES), DIN 60005, with capacity label.



### Technical data model HSE-E one-way-sling

Model	Capacity WLL, with one sling, straight pull kg	Capacity WLL, with one sling, basket, angle $\beta$ up to 7° kg	Capacity WLL, with one sling, basket, angle $\beta$ 7°- 45° kg	Capacity WLL, with one sling, basket, angle $\beta$ 45°- 60° kg	Capacity WLL, with one sling, choke hitch kg	Webbing width mm	Shortest possible length for special makes mm
HSE-E-00500 one-way-sling	500	1000	700	500	400	25	200
HSE-E-00750 one-way-sling	750	1500	1050	750	600	48	200
HSE-E-01000 one-way-sling	1000	2000	1400	1000	800	35	200
HSE-E-01500 one-way-sling	1500	3000	2100	1500	1200	50	250

Flat webbing sling,  
duplex construction,  
reinforced eyes  
model HBD

Made from polyester (PES), EN 1492-1 form B2,  
with capacity label.

Features

- Duplex construction, PU-starched, thermally fixed.
- With reinforced eyes.
- Woven tonnage stripes.
- Low weight allows easy handling.
- Protection against hand injuries.
- Protection against cargo surface damage.
- Consistent pressure distribution onto pressure- and pull sensitive loads.
- UV-resistant, eliminating material ageing or embrittlement.
- Heat resistant up to +100° C.
- Moisture-resistant fabric, thus preventing frost damage (up to approx. -40° C).
- Low elongation (< 4%).



**Rapid production of special lengths is possible because of own manufacture.**

Technical data model HBD

Model	Colour code EN 1492	Capacity WLL, with one sling, straight pull kg	Capacity WLL, with one sling, basket, angle β up to 7° kg	Capacity WLL, with one sling, basket, angle β 7°- 45° kg	Capacity WLL, with one sling, basket, angle β 45°- 60° kg	Capacity WLL, with one sling, choke hitch kg	Webbing width mm	Eye length approx. mm	Eye width approx. mm	Shortest possible length for special makes mm
HBD-01000	violet	1000	2000	1400	1000	800	30	300	15	750
HBD-02000	green	2000	4000	2800	2000	1600	60	350	30	1000
HBD-03000	yellow	3000	6000	4200	3000	2400	90	400	45	1000
HBD-04000	grey	4000	8000	5600	4000	3200	120	500	60	1500
HBD-05000	red	5000	10000	7000	5000	4000	150	550	75	1500
HBD-06000	brown	6000	12000	8400	6000	4800	180	600	90	2000
HBD-08000	blue	8000	16000	11200	8000	6400	240	650	120	2500
HBD-10000	orange	10000	20000	14000	10000	8000	300	900	150	2500

**Other capacities up to 25 t and special lengths available on request.**





## Flat webbing sling, four ply, reinforced eyes model HBQ

Made from polyester (PES), EN 1492-1 form B4, with capacity label.

Colour coding up to 16000 kg not according to EN 1492-1.

### Features

- Four-layered stitched, PU-starched, thermally fixed.
- With reinforced eyes.
- Low weight allows easy handling.
- Protection against hand injuries.
- Protection against cargo surface damage.
- Consistent pressure distribution onto pressure- and pull sensitive loads.
- UV-resistant, eliminating material ageing or embrittlement.
- Heat resistant up to +100° C.
- Moisture-resistant fabric, thus preventing frost damage (up to approx. -40° C).
- Low elongation (< 4%).

**Rapid production of special lengths is possible because of own manufacture.**



**Special lengths available on request.**

### Technical data model HBQ

Model	Capacity WLL, with one sling, straight pull kg	Capacity WLL, with one sling, basket, angle $\beta$ up to 7° kg	Capacity WLL, with one sling, basket, angle $\beta$ 7°- 45° kg	Capacity WLL, with one sling, basket, angle $\beta$ 45°- 60° kg	Capacity WLL, with one sling, choke hitch kg	Webbing width mm	Eye length approx. mm	Eye width approx. mm	Shortest possible length for special makes mm
HBQ-04000	4000	8000	5600	4000	3200	60	350	30	1000
HBQ-06000	6000	12000	8400	6000	4800	90	400	45	1000
HBQ-08000	8000	16000	11200	8000	6400	120	500	60	1500
HBQ-10000	10000	20000	14000	10000	8000	150	550	75	1500
HBQ-12000	12000	24000	16800	12000	9600	180	600	90	2000
HBQ-16000	16000	32000	22400	16000	12800	240	650	120	2500
HBQ-20000	20000	40000	28000	20000	16000	300	900	150	2500
HBQ-25000	25000	50000	35000	25000	20000	300	900	150	2500

Webbing sling,  
duplex construction,  
steel links on both ends  
model HBD-SN and  
model HBD-SD

Made from polyester (PES), EN 1492-1 form Cr2,  
with capacity label.

Features

- Duplex construction, PU-starched, thermally fixed.
- With steel D- and DP-links (reevable).
- Woven tonnage stripes.
- Low weight allows easy handling.
- Protection against hand injuries.
- Protection against cargo surface damage.
- Consistent pressure distribution onto pressure- and pull sensitive loads.
- UV-resistant, eliminating material ageing or embrittlement.
- Heat resistant up to +100° C.
- Moisture-resistant fabric, thus preventing frost damage (up to approx. -40° C).
- Low elongation (< 4%).



**!** Model HBD-SD - links are reevable, webbing sling also applicable for use in choke hitch.

Technical data model HBD-SN and model HBD-SD

Model	Colour code EN 1492	Capacity WLL, with one sling, straight pull kg	Capacity WLL, with one sling, basket, angle $\beta$ up to 7° kg	Capacity WLL, with one sling, basket, angle $\beta$ 7°- 45° kg	Capacity WLL, with one sling, basket, angle $\beta$ 45°- 60° kg	Capacity WLL, with one sling, choke hitch kg	Webbing width mm	Link dimension HBD-SN bxdxt mm 	Link dimension HBD-SD bxdxt mm 
HBD-01000	violet	1000	2000	1400	1000	800	50	50x13x95	50x13x145
HBD-02000	green	2000	4000	2800	2000	1600	60	60x16x90	60x16x165
HBD-03000	yellow	3000	6000	4200	3000	2400	90	90x18x110	90x18x190
HBD-04000	grey	4000	8000	5600	4000	3200	120	120x22x130	120x22x240
HBD-05000	red	5000	10000	7000	5000	4000	150	150x26x170	150x26x300
HBD-06000	brown	6000	12000	8400	6000	4800	180	180x30x200	180x30x320
HBD-08000	blue	8000	16000	11200	8000	6400	240	240x32x230	240x32x360
HBD-10000	orange	10000	20000	14000	10000	8000	300	300x40x290	300x40x435

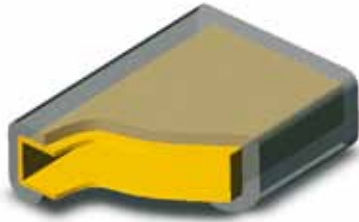

PU-protection sleeve single-sided,  
model PU-SC-1

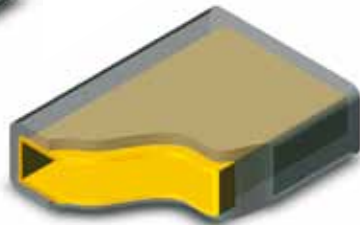

PU-protection sleeve double-sided,  
model PU-SC-2

## PU-protection sleeve, single and double-sided model PU-SC

Made from cut resistant polyurethane

With inner fabric insert to ease sliding of the sleeve on the webbing. Standard length 2 and 4 m.

Double PU sleeves cannot be fitted subsequently on webbing slings with steel links. If required, state sleeve length when placing the webbing sling order.

### Technical data model PU-SC, single-sided

Model	EAN-No. 4025092*	Webbing width mm	Dimensions outside / inside mm	Height mm
PU-SC1-030	*357906	30	50 / 40	22
PU-SC1-050	*352680	50	70 / 60	22
PU-SC1-060	*352697	60	80 / 70	22
PU-SC1-090	*352710	90	110 / 100	22
PU-SC1-120	*357951	120	145 / 135	22
PU-SC1-150	*357876	150	170 / 160	22
PU-SC1-180	*357869	180	200 / 190	22
PU-SC1-240	*357883	240	260 / 250	31
PU-SC1-300	*357890	300	330 / 320	31

### Technical data model PU-SC, double-sided

Model	EAN-No. 4025092*	Webbing width mm	Dimensions outside / inside mm	Height mm
PU-SC2-030	*357944	30	50 / 40	22
PU-SC2-050	*352741	50	70 / 60	22
PU-SC2-060	*352758	60	80 / 70	22
PU-SC2-090	*352772	90	110 / 100	22
PU-SC2-120	*352802	120	145 / 135	22
PU-SC2-150	*352826	150	170 / 160	22
PU-SC2-180	*357913	180	200 / 190	22
PU-SC2-240	*357920	240	260 / 250	31
PU-SC2-300	*357937	300	330 / 320	31

**!** Lengths over 4 m on request.

## PU-edge protector model PU-KSW

Made from cut resistant polyurethane

With slots to allow easy attachment and fixing on the round sling.



### Technical data model PU-KSW

Model	EAN-No. 4025092*	Diameter mm	Length mm	Suitable for round slings up to WLL kg
PU-KSW-30	*357067	30	80	3000
PU-KSW-50	*357074	50	125	5000

## Round sleeve model PU-SG

With fabric insert and PU-coating

Economical solution to protect webbing slings and round slings against wear caused by abrasion.



**!** Not suitable for protection  
against sharp edges.

### Technical data model PU-SG

Model	EAN-No. 4025092*	Width approx. mm	Length mm	Diameter mm	Suitable for round slings up to WLL kg
PU-SG-040	*352840	60	1000	40	2000
PU-SG-063	*352857	95	1000	63	3000
PU-SG-075	*352864	115	1000	75	6000
PU-SG-090	*352871	140	1000	90	8000
PU-SG-110	*352888	170	1000	110	10000
PU-SG-150	*352895	230	1000	150	15000



## Edge protection profile, with and without magnets model PU-KSE

From colour coded polyurethane, extremely abrasive and cut resistant.

### Technical data model PU-KSE

Model	EAN-No. 4025092*	Colour	Webbing width mm	Number of magnets
PU-KSE-065	*912303	green	60	–
PU-KSE-100	*912310	yellow	90	–
PU-KSE-125	*912327	grey	120	–
PU-KSE-150	*912389	red	150	–
PU-KSE-200	*912396	black	180	–
PU-KSE-300	*912402	orange	300	–

### Technical data model PU-KSE-MAG

Model	EAN-No. 4025092*	Colour	Webbing width mm	Number of magnets
PU-KSE-065-MAG	*912419	green	60	2
PU-KSE-100-MAG	*912426	yellow	90	4
PU-KSE-125-MAG	*912433	grey	120	4
PU-KSE-150-MAG	*912440	red	150	4
PU-KSE-200-MAG	*912457	black	180	6
PU-KSE-300-MAG	*912464	orange	300	8

## PU-coating, single and double-sided model PU-FB

Made from transparent polyurethane

Extremely wear and cut resistant. The coating is permanently fixed to the webbing and cannot be lost during usage.

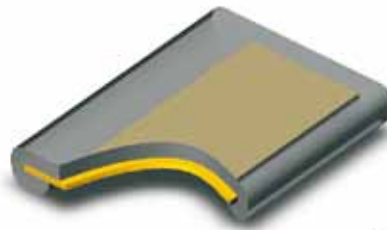

Coating single-sided,  
model PU-FB 1

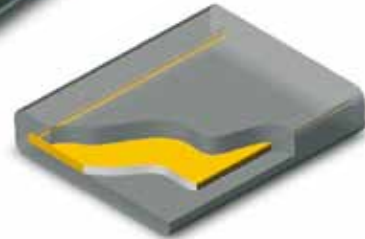

Coating double-sided,  
model PU-FB 2

### Technical data model PU-FB, single-sided

Model	EAN-No. 4025092*	Webbing width mm	Width mm	Length mm
PU-FB1-030	*358620	30	40	1000
PU-FB1-050	*352529	50	60	1000
PU-FB1-060	*352536	60	70	1000
PU-FB1-090	*352543	90	100	1000
PU-FB1-120	*352550	120	130	1000
PU-FB1-150	*352567	150	160	1000
PU-FB1-180	*352574	180	190	1000
PU-FB1-240	*352581	240	250	1000
PU-FB1-300	*352598	300	310	1000

### Technical data model PU-FB, double-sided

Model	EAN-No. 4025092*	Webbing width mm	Width mm	Length mm
PU-FB2-030	*358637	30	40	1000
PU-FB2-050	*352604	50	60	1000
PU-FB2-060	*352611	60	70	1000
PU-FB2-090	*352628	90	100	1000
PU-FB2-120	*352635	120	130	1000
PU-FB2-150	*352642	150	160	1000
PU-FB2-180	*352659	180	190	1000
PU-FB2-240	*352666	240	250	1000
PU-FB2-300	*352673	300	310	1000



## General information about load security

The varying forces, which can result in slipping, rolling, tilting or even lift-off of loads during transport, are regularly underestimated. Possible consequences are e.g. that the vehicle gets out of control, the driving cab is damaged, the vehicle even overturns and the falling load endangers others! The common assumption that very heavy loads do not require lashing security, is a fatal error. Lashing of loads may be performed by competent users (trained in theory and practice) only.

### Some basic rules about load security with ratchet lashings

- Depending on the cargo, consideration shall be given to select an appropriate vehicle with adequate structures and lashing points.
- The load centre of gravity should be as low as possible and ideally positioned according to the load distribution plan of the vehicle.
- The permissible gross weight and loads per axle must not be exceeded.
- The load should be stored as close and low as possible and should not leave free space between load, front wall or side walls. Free spaces between the outer walls and the load should be stuffed where possible.
- Depending on the type of cargo, the driving speed should conform to the road and traffic situation as well as to the driving quality of the vehicle.
- Adverse friction values between cargo and loading area (oily metals, wet areas etc.) will considerably increase the requirement for a correct security of the load. Slip restraining mats will contribute to achieve a more economic and efficient load lashing security.
- Unstable cargo is very susceptible to tilting and in most cases has to be lashed extensively (calculation against slipping and tilting).
- Positive load lashing (e.g. supporting the cargo at front and side walls or with wedges or scantlings fixed on the loading platform) will contribute substantially to the stabilisation of the cargo and to reduction of additional lashing requirement.

## Forces on cargo loads (EN 12195)

### Truck and trailer loading (road transport) – Acceleration coefficients

During road transport the heaviest stresses on the load security equipment will occur during braking, lift-off of the load by vibration and impact as well as centrifugal forces in narrow curves.

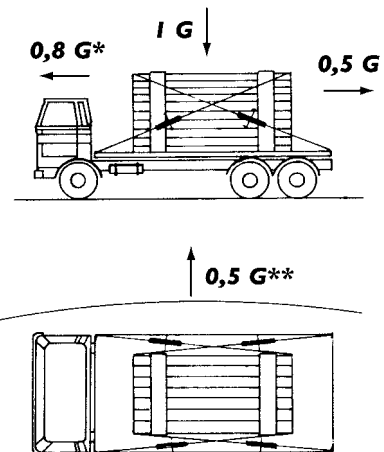

\* The value for the longitudinal acceleration in combined traffic (lorry and/or trailer during rail transport) has to be calculated with 1G.

\*\* 0.7 for tilting of instable cargo loads

## Lashing methods

### Over top lashing

Over top lashing consists of tensioning the lashings to the tension force so as to increase the friction force at the contact surface of the load to avoid any sliding of the load. Influence factors are the dimensions of the load, the acceleration values, the dynamic friction factors as well as the lashing angle. The calculation of lashing forces will give the required tension force of the lashing devices.

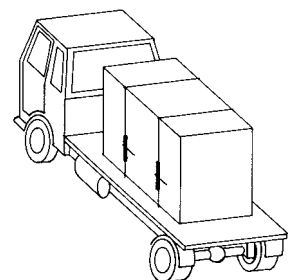

This user information presents a general overview regarding the application of web lashings and does not substitute the existing operating instructions for specific products!

Lashing operations with textile lashing equipment may be carried out by competent users (trained in theory and practice) only. When operated correctly, our textile lashings offer the highest degree of safety in line with long life expectancy and avoid damage to material and people.

## Limitations of use

### Temperature

Textile lashings in accordance with this part of the European standard EN 12195 are suitable for the following temperature areas:

- a) -40° C up to +80° C for polypropylene (PP)
- b) -40° C up to +100° C for polyamide (PA)
- c) -40° C up to +120° C for polyester (PES)

These temperature areas may change in chemical environments. In this case consult the manufacturer or supplier for advice.

A change of the ambient temperature during transport may influence the tension force of the textile lashing. The tension force should be checked after entering warm regions.

### Chemicals

The resistance against chemical influences varies depending on the materials used for the textile lashing. Please observe the advice of the manufacturer, if the textile lashings are subjected to chemicals. Also consider that the effect of the chemical influence will increase with rising temperatures. The resistance of synthetic fibre against chemical influences is summarised as follows:

- a) Polyamides are resistant against alkaline but affected by mineral acids.
- b) Polyester is resistant against mineral acids but affected by alkaline solutions.
- c) Polypropylene is hardly affected by acids and alkaline and is suited for applications that require high resistance against chemicals (except some organic solvents).
- d) Harmless acid or alkaline solutions may be concentrated by evaporation and lead to damages. Affected textile lashings have to be taken out of service immediately, thoroughly rinsed in cold water and dried in the open-air.

### Operation in danger zones

During loading and unloading observe low hanging aerial contact lines.

### Application advices

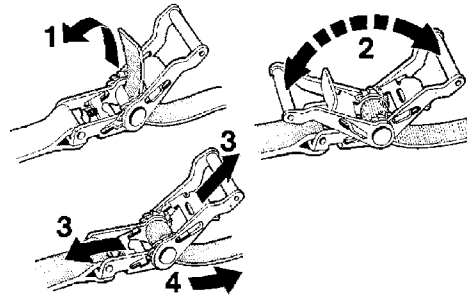

- Selection and use of textile lashings depend on the required tensioning force as well as the mode of application and type of cargo to be lashed. Size, form and weight of the cargo determine the correct choice in addition to the intended usage. For stability reasons, at least two lashing systems should be used for over top lashing and two pairs of lashing straps for diagonal lashing.
- The selected web lashing must be strong enough for the intended job and have the correct length for the type of lashing. Always consider adequate lashing practice: Attachment and removal of lashings should be planned before the start of the journey. In case of longer trips, partial unloadings must be considered. The number of lashings must be calculated as per EN 12195-1:2000. Over top lashing requires systems, which are labelled STF for over top lashing.
- On account of different characteristics and change of length under load, different lashings (e.g. lashing chains and web lashings) may not be used for lashing the same load. When using additional fittings or lashing devices, make sure that these correspond to the existing web lashing.
- During operation, flat hooks must be in contact with the full width of the hook mouth.



- Releasing of the lashing: Prior to releasing, make sure that the load stands safely (even without safety device) and does not endanger the operator by falling. Before departure check whether additional lashings will be required for further transportation after partial unloading has occurred.
- This is also true for lashing elements which permit safe removal.
- Prior to unloading, the lashings must be released to an extent that the load stands freely.
- Make sure that the web lashing will not be damaged by the edges of the cargo. A visual inspection should be standard procedure before and after each usage.
- Only use textile lashings with legible identity labels.
- Textile lashings must not be overloaded:  
The max. hand force of 500 N (50 daN on the label; 1 daN = approx. 1 kg) may be applied with one hand only. Do not use cheater bars or levers unless they are part of the lashing element.
- Knotted textile lashings must not be used.
- Damages to the identity labels should be avoided by keeping them away from the edges of the cargo.
- Textile lashings should be protected against friction and abrasion and damages by sharp edges by application of protective sleeves and/or edge protectors.

## Labelling

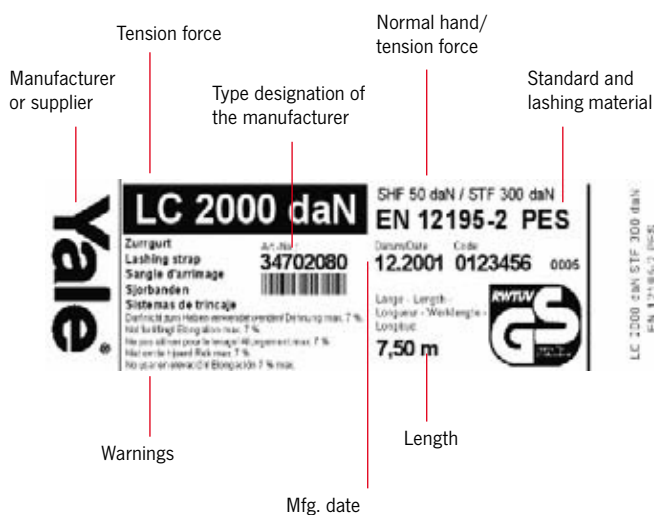

## Maintenance and repair

Textile lashings may only be repaired if provided with legible identity labels. In case of accidental contact with chemicals, the web lashing has to be withdrawn from service and the manufacturer or supplier consulted for advice.

## Criteria for disposal of textile lashings

Textile lashings must be withdrawn from service and returned for repair to the manufacturer in case of obvious defects. The following points are signs of possible damages:

### Textile lashings:

- Cracks, cuts, notches and breaks in the load bearing strands and seams as well as deformations by heat;

### Tensioning devices and fittings:

- Deformations, cracks, obvious signs of wear and corrosion.

## The quantity of textile lashings has to be calculated according to EN 12195-1:2000.

Only use lashing systems for over top lashing which show STF on the label. For easy identification of the required quantity of textile lashings or existing lashings needed for the cargo to be lashed refer to the following table, which has been calculated with friction coefficients of  $\mu = 0.2$ ,  $\mu=0.4$  and  $\mu = 0.6$  at various angles of elevation  $\alpha$ .

- The calculation refers to situations with min. two, however max. ten textile lashings.
- Whenever possible, always use a slip resistant mat with a certified friction coefficient of 0.6!
- Always operate with the highest possible angle of elevation and lash as steep as possible!!!
- The friction coefficients are applicable for clean and dry surfaces, well covered from frost, ice and snow. In case of moisture refer to the direct lashing method or double the amount of textile lashings!

Friction factors according to EN 12195-1:2000 table 5:

Combination of materials in the contact surface	Friction factor $\mu$	when using a slip resistant mat
Cut timber against fabric base laminate/plywood	0.5	0.6
Cut timber against grooved aluminium	0.4	0.6
Cut timber against steel sheets	0.4	0.6
Cut timber against shrink films	0.3	0.6
Shrink films against fabric base laminate/plywood	0.4	0.6
Shrink films against grooved aluminium	0.4	0.6
Shrink films against steel sheets	0.4	0.6
Shrink films against shrink films	0.4	0.6
Cardboard box against cardboard box	0.5	0.6
Cardboard box against wooden pallet	0.5	0.6
Big bags against wooden pallet	0.4	0.6
Flat steel bars against cut timber	0.5	0.6
Unpainted corrugated sheets against cut timber	0.5	0.6
Painted corrugated sheets against cut timber	0.4	0.6
Unpainted corrugated sheets against unpainted corrugated sheets	0.3	0.6
Painted corrugated sheets against painted corrugated sheets	0.2	0.6

Number of required textile lashings for different cargo weights

- at different friction factors
- at different angles

Tension force of ratchet 300 daN at standard hand force of 50 daN according to EN 12195

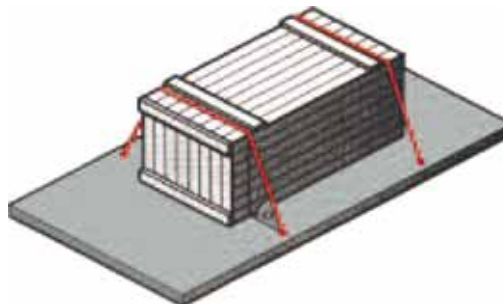

Applicable to textile lashings model ZGR-50-2500 with LC 2500 daN and model ZGR-50-2000 with LC 2000 daN

Cargo weight	Friction factor $\mu$ 0.20 Top angle			Friction factor $\mu$ 0.40 Top angle			Friction factor $\mu$ 0.60 Top angle		
	30°	60°	90°	30°	60°	90°	30°	60°	90°
1000 kg		10	9	7	4	3	3	2	2
2000 kg					8	7	6	3	3
3000 kg						10	9	5	4
4000 kg								7	6
5000 kg								8	7
6000 kg								10	9
7000 kg									10
8000 kg									
9000 kg									
10000 kg									

Cells without indication require more than 10 web lashings. In these cases a reasonable cargo securing can only be obtained by direct lashing method. Obstruction forces by cargo boards and form-fit locking devices have not been considered.



## Cambuckle lashing model ZGK-25-125

Made from polyester (PES), EN 12195-2  
25 mm – lashing capacity LC 125 daN.

### Features

- Standard tension force STF 30 daN at standard hand force SHF 50 daN.
- Standard lengths 4 m and 6 m.

**!** Other lengths on request.

### Technical data model ZGK-25-125

Model	EAN-No. 4025092*	Version	Permissible ratchet force LC daN	Webbing width mm	Webbing length mm
ZGK-25-125-1	*352505	1 piece	125	25	4000
ZGK-25-125-1	*352512	1 piece	125	25	6000



### Ratchet lashing model ZGR-25-250

Made from polyester (PES), EN 12195-2  
25 mm – lashing capacity LC 250 daN.

#### Features

- Standard tension force STF 50 daN at standard hand force SHF 50 daN.
- Standard lengths 4 m and 6 m.



**!** Other lengths on request.

#### Technical data model ZGR-25-250

Model	EAN-No. 4025092*	Version	Permissible ratchet force LC daN	Webbing width mm	Webbing length mm
ZGR-25-250-1	*352017	1 piece	250	25	4000
ZGR-25-250-1	*352024	1 piece	250	25	6000
ZGR-25-250-2-SPH	*352383	2 part - with claw hook	250	25	4000
ZGR-25-250-2-SPH	*352390	2 part - with claw hook	250	25	6000

### Ratchet lashing model ZGR-25-500

Made from polyester (PES), EN 12195-2  
25 mm – lashing capacity LC 500 daN.

#### Features

- Standard tension force STF 100 daN at standard hand force SHF 50 daN.
- Standard lengths 4 m and 6 m.

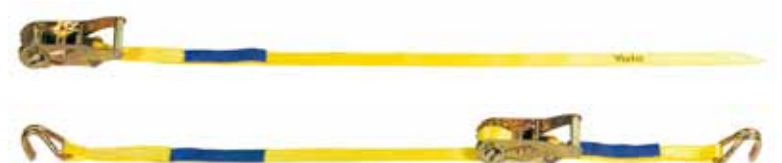

**!** Other lengths on request.

#### Technical data model ZGR-25-500

Model	EAN-No. 4025092*	Version	Permissible ratchet force LC daN	Webbing width mm	Webbing length mm
ZGR-25-500-1	*352031	1 piece	500	25	4000
ZGR-25-500-1	*352048	1 piece	500	25	6000
ZGR-25-500-2-SPH	*352406	2 part - with claw hook	500	25	4000
ZGR-25-500-2-SPH	*352413	2 part - with claw hook	500	25	6000





## Ratchet lashing model ZGR-35-1000

Made from polyester (PES), EN 12195-2  
35 mm – lashing capacity LC 1000 daN.

### Features

- Standard tension force STF 150 daN at standard hand force SHF 50 daN.
- Standard lengths 6 m and 8 m.



GKH - with twisted snap hook



SPH - with claw hook



KLH - with chassis hook



Other end fittings (hooks) and individual prints on webbing are available on request.

### Technical data model ZGR-35-1000

Model	EAN-No. 4025092*	Version	Permissible ratchet force LC daN	Webbing width mm	Webbing length mm
ZGR-35-1000-1	*352055	1 piece	1000	35	6000
ZGR-35-1000-1	*352062	1 piece	1000	35	8000
ZGR-35-1000-2-GKH	*352147	2 part - with snap hook	1000	35	6000
ZGR-35-1000-2-GKH	*352154	2 part - with snap hook	1000	35	8000
ZGR-35-1000-2-KLH	*352208	2 part - with chassis hook	1000	35	6000
ZGR-35-1000-2-KLH	*352215	2 part - with chassis hook	1000	35	8000
ZGR-35-1000-2-SPH	*352420	2 part - with claw hook	1000	35	6000
ZGR-35-1000-2-SPH	*352437	2 part - with claw hook	1000	35	8000

Other lengths on request.



## Ratchet lashing model ZGR-50-2000

Made from polyester (PES), EN 12195-2  
50 mm – lashing capacity LC 2000 daN.

### Features

- Standard tension force STF 300 daN at standard hand force SHF 50 daN.
- Standard lengths 8 m and 10 m.



GKH - with twisted snap hook



SPH - with claw hook



KLH - with chassis hook

Other end fittings (hooks) and individual prints on webbing are available on request.

### Technical data model ZGR-50-2000

Model	EAN-No. 4025092*	Version	Permissible ratchet force LC daN	Webbing width mm	Webbing length mm
ZGR-50-2000-1	*352086	1 piece	2000	50	8000
ZGR-50-2000-1	*352079	1 piece	2000	50	10000
ZGR-50-2000-2-GKH	*352178	2 part - with snap hook	2000	50	8000
ZGR-50-2000-2-GKH	*352161	2 part - with snap hook	2000	50	10000
ZGR-50-2000-2-KLH	*352239	2 part - with chassis hook	2000	50	8000
ZGR-50-2000-2-KLH	*352222	2 part - with chassis hook	2000	50	10000
ZGR-50-2000-FE-KLH	*356640	Fixed end with ratchet	2000	50	400
ZGR-50-2000-2-SPH	*352451	2 part - with claw hook	2000	50	8000
ZGR-50-2000-2-SPH	*352444	2 part - with claw hook	2000	50	10000
ZGR-50-2000-FE-SPH	*356657	Fixed end with ratchet	2000	50	400

Other lengths on request.



## Ratchet lashing model ZGR-50-2500

Made from polyester (PES), EN 12195-2  
50 mm – lashing capacity LC 2500 daN.

### Features

- Standard tension force STF 300 daN at standard hand force SHF 50 daN.
- Standard lengths 8 m and 10 m



GKH - with twisted snap hook



SPH - with claw hook



KLH - with chassis hook

**Other end fittings (hooks) and individual prints on webbing are available on request.**

### Technical data model ZGR-50-2500

Model	EAN-No. 4025092*	Version	Permissible ratchet force LC daN	Webbing width mm	Webbing length mm
ZGR-50-2500-1	*352109	1 piece	2500	50	8000
ZGR-50-2500-1	*352093	1 piece	2500	50	10000
ZGR-50-2500-2-GKH	*352192	2 part - with snap hook	2500	50	8000
ZGR-50-2500-2-GKH	*352185	2 part - with snap hook	2500	50	10000
ZGR-50-2500-2-KLH	*352253	2 part - with chassis hook	2500	50	8000
ZGR-50-2500-2-KLH	*352246	2 part - with chassis hook	2500	50	10000
ZGR-50-2500-FE-KLH	*356664	Fixed end with ratchet	2500	50	400
ZGR-50-2500-2-SPH	*352475	2 part - with claw hook	2500	50	8000
ZGR-50-2500-2-SPH	*352468	2 part - with claw hook	2500	50	10000
ZGR-50-2500-FE-SPH	*356671	Fixed end with ratchet	2500	50	400

**Other lengths on request.**

## Ratchet lashing model ZGR-75-5000

Made from polyester (PES), EN 12195-2  
75 mm – lashing capacity LC 5000 daN.

### Features

- Standard tension force STF 500 daN at standard hand force SHF 50 daN.
- Standard lengths 2 m and 4 m.



SPH - with claw hook

**!** Other end fittings (hooks) and individual prints on webbing are available on request.

### Technical data model ZGR-75-5000

Model	EAN-No. 4025092*	Version	Permissible ratchet force LC daN	Webbing width mm	Webbing length mm
ZGR-75-5000-1	*352116	1 piece	5000	75	2000
ZGR-75-5000-1	*352123	1 piece	5000	75	4000
ZGR-75-5000-2-SPH	*352482	2 part - with claw hook	5000	75	2000
ZGR-75-5000-2-SPH	*352499	2 part - with claw hook	5000	75	4000

**!** Other lengths on request.



## Ratchet lashing with long lever ratchet model ZGR-XL-50-2000 or model ZGR-XLZ-50-2000

Made from polyester (PES), EN 12195-2  
50 mm – lashing capacity LC 2000 daN.

### Features

- Standard tension force STF 500 daN at standard hand force SHF 50 daN.
- Long lever ratchet with precise interlocking.
- Long lever push ratchet model ZGR-XL with device for controlled release.
- Long lever pull ratchet model ZGR-XLZ, ergonomic design.
- Standard lengths 8 m and 10 m.

Other end fittings (hooks) and individual prints on webbing are available on request.

Other lengths on request.



Long lever ratchet with precise interlocking. Device for controlled release.

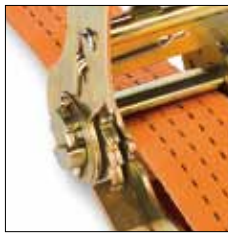

GKH - with twisted snap hook



SPH - with claw hook



KLH - with chassis hook

### Technical data model ZGR-XL-50-2000 with device for controlled release

Model	EAN-No. 4025092*	Version	Permissible ratchet force LC daN	Webbing width mm	Webbing length mm
ZGR-XL-50-2000-1	*360579	1 piece	2000	50	8000
ZGR-XL-50-2000-1	*360562	1 piece	2000	50	10000
ZGR-XL-50-2000-2-GKH	*360593	2 part - with snap hook	2000	50	8000
ZGR-XL-50-2000-2-GKH	*360586	2 part - with snap hook	2000	50	10000
ZGR-XL-50-2000-2-KLH	*360616	2 part - with chassis hook	2000	50	8000
ZGR-XL-50-2000-2-KLH	*360609	2 part - with chassis hook	2000	50	10000
ZGR-XL-50-2000-2-SPH	*360630	2 part - with claw hook	2000	50	8000
ZGR-XL-50-2000-2-SPH	*360623	2 part - with claw hook	2000	50	10000

### Technical data model ZGR-XLZ-50-2000 ergonomic design

Model	EAN-No. 4025092*	Version	Permissible ratchet force LC daN	Webbing width mm	Webbing length mm
ZGR-XLZ-50-2000-1	*646260	1 piece	2000	50	8000
ZGR-XLZ-50-2000-1	*646284	1 piece	2000	50	10000
ZGR-XLZ-50-2000-2-GKH	*646352	2 part - with snap hook	2000	50	8000
ZGR-XLZ-50-2000-2-GKH	*646369	2 part - with snap hook	2000	50	10000
ZGR-XLZ-50-2000-2-KLH	*646390	2 part - with chassis hook	2000	50	8000
ZGR-XLZ-50-2000-2-KLH	*646406	2 part - with chassis hook	2000	50	10000
ZGR-XLZ-50-2000-2-SPH	*475549	2 part - with claw hook	2000	50	8000
ZGR-XLZ-50-2000-2-SPH	*475556	2 part - with claw hook	2000	50	10000

## Ratchet lashing with long lever ratchet model ZGR-XL-50-2500 or model ZGR-XLZ-50-2500

Made from polyester (PES), EN 12195-2  
50 mm – lashing capacity LC 2500 daN.



### Features

- Standard tension force STF 500 daN at standard hand force SHF 50 daN.
- Long lever ratchet with precise interlocking.
- Long lever push ratchet model ZGR-XL with device for controlled release.
- Long lever pull ratchet model ZGR-XLZ, ergonomic design.
- Standard lengths 8 m and 10 m.

**Other end fittings (hooks) and individual prints on webbing are available on request.**  
**Other lengths on request.**



Long lever ratchet with precise interlocking. Device for controlled release.

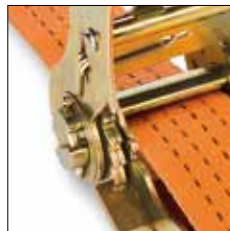

GKH - with twisted snap hook



SPH - with claw hook



KLH - with chassis hook

### Technical data model ZGR-XL-50-2500 with device for controlled release

Model	EAN-No. 4025092*	Version	Permissible ratchet force LC daN	Webbing width mm	Webbing length mm
ZGR-XL-50-2500-1	*360654	1 piece	2500	50	8000
ZGR-XL-50-2500-1	*360647	1 piece	2500	50	10000
ZGR-XL-50-2500-2-GKH	*360678	2 part - with snap hook	2500	50	8000
ZGR-XL-50-2500-2-GKH	*360661	2 part - with snap hook	2500	50	10000
ZGR-XL-50-2500-2-KLH	*360692	2 part - with chassis hook	2500	50	8000
ZGR-XL-50-2500-2-KLH	*360685	2 part - with chassis hook	2500	50	10000
ZGR-XL-50-2500-2-SPH	*360715	2 part - with claw hook	2500	50	8000
ZGR-XL-50-2500-2-SPH	*360708	2 part - with claw hook	2500	50	10000

### Technical data model ZGR-XL-50-2500 ergonomic design

Model	EAN-No. 4025092*	Version	Permissible ratchet force LC daN	Webbing width mm	Webbing length mm
ZGR-XLZ-50-2500-1	*646291	1 piece	2500	50	8000
ZGR-XLZ-50-2500-1	*646321	1 piece	2500	50	10000
ZGR-XLZ-50-2500-2-GKH	*646376	2 part - with snap hook	2500	50	8000
ZGR-XLZ-50-2500-2-GKH	*646383	2 part - with snap hook	2500	50	10000
ZGR-XLZ-50-2500-2-KLH	*646413	2 part - with chassis hook	2500	50	8000
ZGR-XLZ-50-2500-2-KLH	*646420	2 part - with chassis hook	2500	50	10000
ZGR-XLZ-50-2500-2-SPH	*475563	2 part - with claw hook	2500	50	8000
ZGR-XLZ-50-2500-2-SPH	*475570	2 part - with claw hook	2500	50	10000



Other lengths on request.

## Truck lashing model ZGR-SLE

Made from polyester, EN 12195-2

With rail anchor suitable for fixing rails.

### Technical data model ZGR-SLE

Model	EAN-No. 4025092*	Version	Permissible ratchet force LC daN	Webbing width mm	Length fixed end LGF mm	Length loose end LGL mm
ZGR-50-1000-2-SLE	*356527	2 part	1000	50	1000	3000



## Container lashing model ZGR-CZR

Made from polyester, EN 12195-2

Container lashing with ratchet and round sling with reinforced loop and protection hose.

### Technical data model ZGR-CZR

Model	EAN-No. 4025092*	Version	Permissible ratchet force LC daN	Webbing width mm	Round sling 3000 kg, useable length mm	Length fixed end LGF mm	Length loose end LGL mm
ZGR-50-2500-2-CZR	*356534	2 part	2500	50	1150	400	600



## Ratchet base model ZGZB-RU

Manufactured from cut resistant polyurethane.

Can also be used as edge protector.

### Technical data model ZGZB-RU

Model	EAN-No. 4025092*	For webbing width mm
ZGZB-RU-PU-50	*352901	35 - 50
ZGZB-RU-PU-75	*352918	75

## Wheel lashing model ZGR-DSPH

Made from polyester, EN 12195-2

With D-ring and ratchet and claw hook.



### Technical data model ZGR-DSPH

Model	EAN-No. 4025092*	Version	Permissible ratchet force LC daN	Webbing width mm	Webbing length mm
ZGR-35-1000-1-DSPH	*356541	1 piece	1000	35	2300

## Car-Lashing (wheel-lashing) model ZGR-CL

Made from polyester, EN 12195-2

### Scope of delivery

- Ratchet with integrated swivel hook
- Belt with single J-hook
- Single J-hook loosely attached to belt
- Protective tyre sleeve  
(one side coated with special rubber)



### Technical data model ZGR-CL

Model	EAN-No. 4025092*	Version	Permissible ratchet force LC daN	Webbing width mm	Webbing length mm
ZGR-35-1500-1-EWR	*928373	1 piece	1500	35	2500
ZGR-35-1500-2-E-E-E	*928359	2 part	1500	35	2500
ZGR-50-2500-1-EWR	*928380	1 piece	2500	50	2500
ZGR-50-2500-2-E-E-E	*928366	2 part	2500	50	2500



Ratchet with swivel hook



Single J-hook



Protective tyre sleeve





### Edge protector model ZGZB-KS

Edge protector for lashing sensitive loads (cardboard boxes etc.).

#### Technical data model ZGZB-KS

Model	EAN-No. 4025092*	For webbing width mm
ZGZB-KS-PP-50	*352949	50



### Edge protector profile model ZGZB-KSP

Manufactured from polypropylene or recycled cardboard, to protect edges of loads. Length up to 4 m.

#### Technical data model ZGZB-KSP

Model	EAN-No. 4025092*	Dimensions mm
ZGZB-KSP-PP	*356688	190x190x20

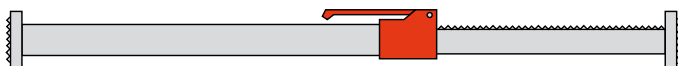

### Load stabilizer bar model ZGZB-KBR

Load stabilizer bars are used to secure loads between bulkheads or between floor and ceiling.

#### Technical data model ZGZB-KBR

Model	EAN-No. 4025092*	Weight kg	Clamping range from - up to mm
ZGZB-KBR-3100	*352994	7.5	2300 - 3100

## Slip restraining mats model ZGZB-ARM

Manufactured from compressed rubber granulate to achieve a defined friction coefficient of  $\mu = 0.6$ .  
Even if an emergency stop or evasive action is being taken – the cargo trucks or train wagons must not move. But only in very few cases the vehicle structure alone will offer sufficient load security.

For this reason, slip restraining devices should belong to the standard equipment of every professional transport. Slip restraining mats will decrease the danger which emanates from plain loading platforms. They will reduce the required total pre-tensioning forces during over top lashing of loads and will contribute – together with the textile lashings – that the loads will form a single unit with the vehicle or wagon.

The slip restraining effect will benefit especially those products, which do not stand a high surface pressure. The dangers resulting from incorrect load lashing practices are often underestimated. Acceleration forces in standard driving situations are close to the dead weight of the load.

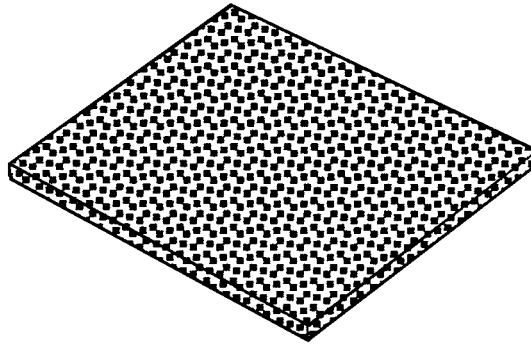

### Technical data model ZGZB-ARM

Model	EAN-No. 4025092*	Dimensions mm
ZGZB-ARM-250-8	*352963	1000 x 250 x 8

The friction force FW of a slip restraining mat impedes load displacement and is physically explained as follows:

$$FW = m \times G$$

G = Weight force

m = Friction value

The difference between inertial force F and friction force FW is called securing force FS.

$$FS = F - FW$$

The securing force FS is the strength which has to be absorbed by the safety devices.

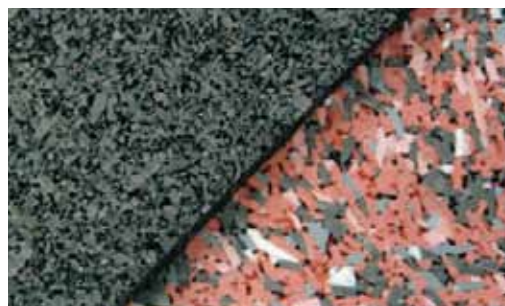



## Load binders model RLSP

Lashing capacity 4000 - 10600 daN

The load binder is a universal tool to restrain and secure loads and freight. Manual operation of the binder lever extends or retracts the threaded spindles. Tension is upheld by the self-locking threads.

The load binder is fitted with shortening hooks for direct attachment to chains or with clevis ends for use with existing fastening devices.

### Technical data model RLSP

Model	EAN-No. 4025092*	Version	Lashing capacity LC daN	Weight kg
RLSP-08-ÖÖ	*457880	Clevis	4000	3.6
RLSP-10-ÖÖ	*457897	Clevis	6300	3.6
RLSP-13-ÖÖ	*457903	Clevis	10600	3.8
RLSP-08-HH	*457859	Shortening hooks	4000	4.5
RLSP-10-HH	*457866	Shortening hooks	6300	5.5
RLSP-13-HH	*457873	Shortening hooks	10600	8.4

### Dimensions model RLSP

Model	RLSP-08-ÖÖ	RLSP-10-ÖÖ	RLSP-13-ÖÖ	RLSP-08-HH	RLSP-10-HH	RLSP-13-HH
Chain size, mm	8	10	13	8	10	13
B1, mm	250	250	250	250	250	250
B2 min., mm	360	360	366	588	630	722
B2 max., mm	510	510	516	738	780	872
Ø E, mm	20	20	25	-	-	-
L, mm	360	360	360	360	360	360

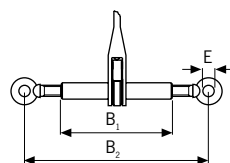

Load binder with protection  
against unscrewing,  
clevis acc. to EN 12195-3 on  
both ends.

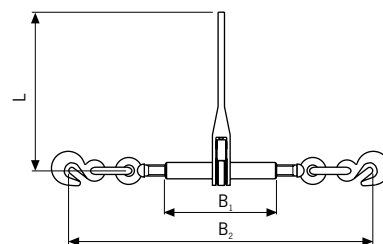

Load binder with protection  
against unscrewing,  
clevis or shortening hook acc. to EN 12195-3 on  
both ends.

## Weld-on hooks model ASH

Capacity 1000 - 8000 kg

Weld-on hooks model ASH are universal attachments for use on trucks, excavators, low loaders and spreader beams, etc. The forged safety latch has high lateral stability and an ergonomic shape. Every weld-on hook has an identification number so that its history can be traced back through forging to the origin of the material.

The hook can be welded without any special preparation, e.g. prewarming.

The hook and safety latch are epoxy resin coated for added corrosion protection, the return spring is made from stainless steel.



### Technical data model ASH

Model	EAN-No. 4025092*	Capacity kg	Weight kg
ASH 1	*453073	1000	0.5
ASH 3	*453011	3000	1.3
ASH 5	*453028	5000	2.4
ASH 8	*453035	8000	3.6

### Dimensions model ASH

Model	ASH 1	ASH 3	ASH 5	ASH 8
Seam density, a	4	6	7	8 - 9
L1 x B1, mm	90 x 25	130 x 35	160 x 45	170 x 50
B2, mm	19	26	30	40
C, mm	24	32	40	51
H1, mm	6	10	12	12
H2, mm	76	117	121	142
L2, mm	22	29	47	52

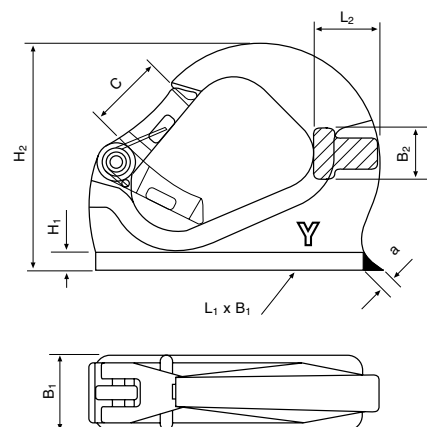

This user information presents a general review regarding the application of personal protective equipment and does not substitute the existing operating instructions for specific products!

Personal protective equipment may be used by a competent operator (trained in theory and practice) only.

When operated correctly, our personal protective equipment will offer the highest degree of safety in line with long life expectancy and avoid damage to products and people.

## Limitations of application

### Utilization period

The utilization period is dependent on the respective conditions of use; observe the information given in the operating instruction. Textile fabric straps and fasteners are subject to a certain ageing process even without operational demands which depend especially on ultraviolet radiation as well as climatic and other environmental influences. On account of this imponderability, specific information cannot be given. Based on experience and under normal operating conditions, the maximum service life of harnesses is 6-8 years, while ropes/straps should be replaced every 4-6 years.

### Temperature

Textile fabric must be protected from temperatures above 60° C. Observe any melting on straps. In such cases, a competent person should be consulted prior to next using the equipment.

## Application advices

### Obligations of employees

Utilisation of personal protective equipment (personal responsibility).

- Prior to each use, the insured users should visually check the equipment for perfect condition and proper function.
- Do not perform any modifications to the equipment.
- Inspection of personal protective equipment for obvious deficiencies, defective parts (open seams, fissures, etc.).

## Maintenance, cleaning and repair

The contractor has to arrange that defective parts of personal protective equipment are replaced only by spares which correspond to the original parts. After the end of the work, the fall arrest equipment should be cleaned from dirt with warm water up to 30° C and a mild washing agent, dry in the shade. Lubricate moving parts of the metal connections if necessary. Personal fall arrest equipment must not be stored under influences, which can negatively affect the safe condition. These are:

- Store in a dry, ventilated and not too warm place.
- Do not dry in the vicinity of radiators.
- Do not expose the harness to aggressive elements, e.g. acids, alkaline, soldering water or oil.
- The equipment should be protected from direct light effect and UV radiation.





### Inspections – 3-level-check

- Prior to and after each use the personal protective equipment should be inspected for obvious deficiencies.
- The equipment has to be checked for obvious failures during utilisation.
- Annual inspection and mandatory documentation of the result.

#### Inspection of the general state of the PPE regarding:

- Completeness
- Correct configuration
- Age
- Existing CE identification marking.
- Identification of manufacturer
- ID number (serial number, charge number etc.)
- Contamination, staining
- Traces of detrimental chemical or thermal influences.
- Signs of manipulation.

The contractor is responsible to have personal protective equipment inspected according to the operating conditions and internal requirements at least once per year by a competent person in order to certify proper state and function. Inspections have to be recorded and must be available during the full period of utilisation.

#### Inspection after use

Personal protective equipment that has been used in a fall must be inspected by a competent person before further use. Repairs must only be carried out by a competent person.





## Single point harness model AFG-10

Conform to EN 361

- Provided with rear 'D' attachment point and chest lock.
- Adjustment in the shoulder and leg area to provide easy and quick fit to the size of the user.

### Technical data model AFG-10

Model	EAN-No.	Weight kg
AFG-10	4025092* *164610	0.8



## Two point harness model AFG-35

Conform to EN 361

- Provided with front and rear 'D' attachment points and chest lock.
- Adjustment in the shoulder and leg area to provide easy and quick fit to the size of the user.

### Technical data model AFG-35

Model	EAN-No.	Weight kg
AFG-35	4025092* *164627	1.2



### Three point harness model AFG-20

Conform to EN 361, EN 358

- Provided with rear 'D' attachment point and chest lock.
- Two lateral 'D' rings for work positioning.
- Padded back for optimal wearing comfort.
- Adjustment in the shoulder and leg area to provide easy and quick fit to the size of the user.



#### Technical data model AFG-20

Model	EAN-No. 4025092*	Weight kg
AFG-20	*164658	1.4

### Four point harness model AFG-56

Conforms to EN 361, EN 358

- Provided with front and rear 'D' attachment points.
- Two lateral 'D' rings for work positioning.
- Padded back for optimal wearing comfort.
- Adjustment in the shoulder and leg area to provide easy and quick fit to the size of the user.



#### Technical data model AFG-56

Model	EAN-No. 4025092*	Weight kg
AFG-56	*164672	1.6



## Four point harness model AFG-56 C

Conform to EN 361, EN 358

- Provided with front and rear 'D' attachment points.
- Two lateral 'D' rings for work positioning.
- Padded back for optimal wearing comfort.
- Quick connect buckles to get the harness quickly on and off.
- Adjustment in the shoulder and leg area to provide easy and quick fit to the size of the user.

### Technical data model AFG-56 C

Model	EAN-No. 4025092*	Weight kg
AFG-56 C	*165297	1.6



## Five point harness model AFG-70

Conform to EN 361, EN 358, EN 813

- Provided with front and rear 'D' attachment points.
- One ventral and two lateral 'D' rings for work positioning.
- Additional equipment loops.
- Padded back and legs for optimal wearing comfort.
- Adjustment in the shoulder and leg area to provide easy and quick fit to the size of the user.

### Technical data model AFG-70

Model	EAN-No. 4025092*	Weight kg
AFG-70	*164733	1.7

### Five point harness model AFG-80

Conform to EN 361, EN 358, EN 813

- Provided with front and rear 'D' attachment points.
- One ventral and two lateral 'D' rings for work positioning.
- Additional equipment loops.
- Padded back and legs for optimal wearing comfort.
- Adjustment in the shoulder and leg area to provide easy and quick fit to the size of the user.
- Seat strap to prevent buckling of leg straps in case of falling.



#### Technical data model AFG-80

Model	EAN-No. 4025092*	Weight kg
AFG-80	*626712	1.7

### Rescue harness model AFG-10 R

Conform to EN 361, EN 1497

- Provided with front and rear 'D' attachment points.
- Additional rescue anchorage point.
- Adjustment in the shoulder and leg area to provide easy and quick fit to the size of the user.



#### Technical data model AFG-10 R

Model	EAN-No. 4025092*	Weight kg
AFG-10R	*164634	1.5



Technical data model VBM-K

Model	EAN-No. 4025092*	Length m
VBM-K	*165310	2.0

Restraint rope lanyard,  
not adjustable  
model VBM-K

Conform to EN 354

- Universal safety lanyard without energy absorber.
- Rope diameter 12 mm
- End connections:  
1 x screw gate snap hook, opening 18 mm,  
1 x standard snap hook, opening 18 mm.



Technical data model VBM-R

Model	EAN-No. 4025092*	Length m
VBM-R	*164948	2.0

Restraint rope lanyard  
not adjustable  
model VBM-R

Conform to EN 354

- Universal safety lanyard without energy absorber.
- Rope diameter 12 mm
- End connections:  
1 x scaffold hook, opening 60 mm,  
1 x standard snap hook, opening 18 mm.



Webbing sling  
model AVM-G

Conform to EN 354

Webbing sling to be used as anchor sling

Technical data model AVM-G

Model	EAN-No. 4025092*	Length m
AVM-G 060	*165242	0.6
AVM-G 150	*240956	1.5

### Shock-absorbing lanyard model BFD-K

Conform to EN 355

- Abrasion-proof webbing with energy absorber.
- Width 30 mm
- End connections:
  - 1 x screw gate snap hook, opening 18 mm,
  - 1 x standard snap hook, opening 18 mm.



#### Technical data model BFD-K

Model	EAN-No. 4025092*	Length m
BFD-K 1,5	*188494	1.5
BFD-K 2,0	*165327	2.0

### Shock-absorbing lanyard model BFD-R

Conform to EN 355

- Abrasion-proof webbing with energy absorber.
- Width 30 mm
- End connections:
  - 1 x standard snap hook, opening 18 mm,
  - 1 x scaffold hook, opening 60 mm.



#### Technical data model BFD-R

Model	EAN-No. 4025092*	Length m
BFD-R 1,5	*188500	1.5
BFD-R 2,0	*165341	2.0

### Twin-tail shock-absorbing lanyard model BFD-T

Conform to EN 355

- Abrasion-proof twin-tail webbing with energy absorber.
- Width 30 mm
- End connections:
  - 1 x standard snap hook, opening 18 mm,
  - 2 x scaffold hook, opening 60 mm.



#### Technical data model BFD-T

Model	EAN-No. 4025092*	Length m
BFD-T	*165334	2.0



### Work positioning device model PHS-K

Conform to EN 358

- Protective sleeve for protection of the rope against abrasion and dirt.
- With rope shortener to adjust the length of the rope.
- Rope diameter 14 mm
- End connections:
  - 1 x screw gate snap hook, opening 18 mm,
  - 1 x standard snap hook, opening 18 mm.

#### Technical data model PHS-K

Model	EAN-No. 4025092*	Length m
PHS-K 2,0	*165358	2.0
PHS-K 4,0	*165365	4.0

### Screw gate snap hook model BS-011

Opening 18 mm

EAN-No. 4025092240925



### Carrying case model AX-322

EAN-No. 4025092165228



### Scaffold hook model EHR-023

Opening 60 mm

EAN-No. 4025092240932



### Kit bag

EAN-No. 4025092165211





## Fall arrest block model HSG-S

Conform to EN 360

- Plastic housing
- Fall indicator
- Galvanized steel rope (diameter 4 mm).
- Rope lengths 6 up to 28 m.
- End connection:  
screw gate snap hook AXK 10SI, opening 23 mm
- Useable up to 120 kg



### Technical data model HSG-S

Model	EAN-No. 4025092*	Length m	Weight kg	Dimensions mm
HSG-S-6	*165006	6.0	5.10	208x85x280
HSG-S-10	*165013	10.0	5.30	208x85x280
HSG-S-15	*165020	15.0	6.10	208x85x280
HSG-S-20	*165037	20.0	11.25	260x120x340
HSG-S-25	*165044	25.0	11.50	260x120x340
HSG-S-28	*165068	28.0	11.65	260x120x340

## Fall arrest block model HSG-G

Conform to EN 360

- Plastic housing
- Fall indicator
- Abrasion-proof 45 mm wide webbing with energy absorber.
- End connections:  
1 x screw gate snap hook, opening 18 mm,  
1 x screw gate snap hook AXK 10S, opening 22 mm.
- Useable up to 120 kg



### Technical data model HSG-G

Model	EAN-No. 4025092*	Length m	Weight kg	Dimensions mm
HSG-G	*165075	2.25	1.2	115x80x150

Depicted rescue winch optionally available.



## Tripod model DRB

Conform to EN 795

- With webbing strap
- Working load limit (WLL) 500 kg
- Breaking force 22 kN
- Closed height: 1.5 m and 1.75 m
- Weight: 13.6 resp. 14.3 kg

### Technical data model DRB

Model	EAN-No. 4025092*	Height m
DRB-8	*165112	1340 - 2140
DRB-9	*165136	1340 - 2300

Hook and pulley included.



## Winch model REW-K

Conform to EN 1496 class B

- With automatic brake c/w mounting bracket.
- Working load limit (WLL) 180 kg
- Breaking force 18 kN
- Galvanized steel rope (diameter 6.3 mm).
- Weight: 13 resp. 14 kg

### Technical data model REW-K

Model	EAN-No. 4025092*	Length m
REW-K 20	*165150	20
REW-K 25	*165167	25

## Anchor beam model TTV-1

Conform to EN 795 class B

- Adjustment range 350 up to 1240 mm
- Dimensions 1415 x 150 x 100 mm



### Technical data model TTV-1

Model	EAN-No. 4025092*	Weight m
TTV-1	*165174	6.9

### Detachable rope grab device model MLA-F

Conform to EN 353-2

- Rope grab with energy absorber.
- Rope diameter Ø 12 mm
- Rope length 5 up to 20 m
- End connection:  
standard snap hook, opening 18 mm.



#### Technical data model MLA-F

Model	EAN-No. 4025092*	Rope length m	Rope diameter mm
MLA-F-5	*928472	5	12
MLA-F-10	*928489	10	12
MLA-F-15	*928496	15	12
MLA-F-20	*928502	20	12

### Detachable rope grab device model MLA-K

Conform to EN 353-2

- Detachable rope grab with energy absorber.
- Use only in conjunction with polyamide kernmantle rope model KMS-K, rope diameter 14 mm.
- End connection:  
standard snap hook, opening 18 mm.



#### Technical data model MLA-K

Model	EAN-No. 4025092*
MLA-K	*165204

### Polyamide kernmantle rope model KMS-K

Conform to EN 353-2

- Suitable with fall arrester with rope grab model MLA-K.
- Rope diameter Ø 14 mm
- End connection:  
screw gate snap hook, opening 18 mm.



#### Technical data model KMS-K

Model	EAN-No. 4025092*	Length m
KMS-K 10	*240833	10
KMS-K 20	*165266	20



### Restraint kit

- Single point harness AFG-10
- Restraint rope lanyard, not adjustable, VBM-K
- Kit bag

#### Technical data restraint kit

Model	EAN-No.
Restraint kit	4025092* *164764

**!** For restraint purposes only!  
Not to be used for fall arrest!



### Basic kit

- Single point harness AFG-10
- Shock-absorbing lanyard BFD-K, length: 2.0 m
- Kit bag

#### Technical data basic kit

Model	EAN-No.
Basic kit	4025092* *164771

### Scaffolders kit

- Single point harness AFG-10
- Shock-absorbing lanyard BFD-R, length: 2.0 m
- Kit bag



#### Technical data scaffolders kit

Model	EAN-No.
Scaffolders kit	4025092* *164788

### Construction kit

- Two point harness AFG-35
- Fall arrest block HSG-G
- Webbing sling AVM-G, length: 0.6 m
- Kit bag



#### Technical data construction kit

Model	EAN-No.
Construction kit	4025092* *164795



### Construction kit 2

- Single point harness AFG-35
- Fall arrest block HSG-S, length: 10.0 m
- Webbing sling AVM-G, length: 0.6 m
- Carrying case

#### Technical data construction kit 2

Model	EAN-No.
Construction kit 2	4025092*
	*164818



### Crane maintenance kit

- Single point harness AFG-35
- Shock-absorbing lanyard BFD-T
- Kit bag

#### Technical data crane maintenance kit

Model	EAN-No.
Crane maintenance kit	4025092*
	*164856



### Roofers kit

- Single point harness AFG-35
- Fall arrester with rope grab MLA-K
- Polyamide kernmantle rope, length: 20.0 m (Rope diameter: 14 mm)
- Webbing sling AVM-G, length: 0.6 m
- Carrying case

#### Technical data roofers kit

Model	EAN-No.
Roofers kit	4025092*
	*164863



### Work positioning kit

- Single point harness AFG-56
- Fall arrest block HSG-G
- Work positioning device PHS-K, length: 2.0 m
- Kit bag

#### Technical data work positioning kit

Model	EAN-No.
Work positioning kit	4025092*
	*164887







Hand pallet trucks



Hand pallet trucks with weighing system



Scissor pallet trucks



Electric pallet trucks

 Please note our user instructions at the beginning of each chapter.

## Material Handling Equipment

Pfaff-silberblau industrial trucks are ideal for transporting and stacking loads on pallets in factories.

The comprehensive range of products offers the correct model for numerous applications; be it for different route lengths or degrees of utilization, gradients and ramps or areas with a corrosion hazard.

From pallet trucks, manual stackers to electric stackers and elevating platforms – you will find the appropriate solution.

## Load Moving Systems

Yale heavy load moving systems for the safe transportation of heavy loads of up to 100 t.

Products range from separately used load moving skates to complete systems.

## Table of Contents

	Page
Hand pallet trucks	290 - 301
Hand pallet trucks with weighing system	302 - 305
Scissor pallet trucks	306 - 307
Electric pallet trucks	308 - 311
Manual drive stackers	312 - 317
Electric pedestrian stackers	318 - 322
Elevating platforms	323 - 331
Load moving systems	332 - 337



Manual drive stackers



Load moving systems

**This user information presents a general review regarding the application of material handling equipment and does not substitute the existing operating instructions for specific industrial trucks and elevating platforms!**

**Operating industrial trucks as well as lifting operations must be carried out by competent persons. When operated correctly, our products will offer the highest degree of safety, avoid damage to products and people and present a long life expectancy.**

## Modification of delivery condition

Design and construction of material handling products must not be altered by e.g. assembly of outside supplied components, bending, welding, grinding, cutting-off parts, adding boreholes, removal of safety devices or fitting of attachments.

## Limitations of operation

### Loading

The rated capacity (WLL) indicated on the product is the maximum load which must not be exceeded.

### Transport of people

Transport of people with industrial trucks is generally forbidden!

### Operation in danger zones

Lifting or transport of loads must be avoided while personnel are in the danger zone.

Do not allow people to stay on or below a raised load.

Do not place hands or feet under the raised fork frame or load on account of the imminent danger of crushing or shearing.

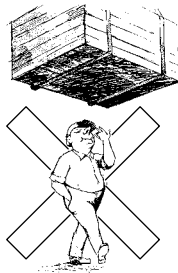

## Inspection before starting work

- Prior to starting work, the unit must be inspected for obvious deficiencies and failures. Operational checks must be performed to ensure lifting, lowering and travel operate correctly.
- Check the parking brake is effective and the key switch operates correctly to protect against unauthorised use.
- Load carriage and forks must not show obvious defects (deflections, cracks or other wearing).
- Wheels and tires must not be defective.
- The hydraulic system must be in perfect order (lifting, lowering, density).
- The functional capability of the collision protective device should be checked.
- Battery charging status, fastening and cable connections of the battery as well as battery plug must be inspected for appropriate status as well as the battery cell lids (dry, clean).

**For information on training please see page 4-5.**

## Application advices

- Our material handling equipment must be operated on in-plant areas only.
- Only use industrial trucks in perfect condition and with legible identity plate.
- Industrial trucks may only be operated by skilled people, who have been instructed (in theory and practice) by the responsible user.
- The travel speed must conform to local conditions.
- Industrial trucks must be operated on flat, level and even ground.
- The operator must make sure that the load unit is in perfect condition and safely attached.
- Pallets may be transported individually only.
- Industrial trucks must not be used as car jacks.
- Industrial trucks must not be used in areas which are not illuminated sufficiently.
- Forks may not be used as levers.
- Loading of just one fork, e.g. for lifting of a machine, is strictly forbidden.
- Industrial trucks may not be operated in direct contact with foodstuffs.
- Never turn the hand lever 90° in order to stop the truck.
- The industrial truck must not be operated in explosive atmospheres (special versions on request).

## Maintenance and repair

- To ensure safe operation, all material handling equipment must be subjected to regular inspections according to the maintenance instructions provided by the manufacturer.
- Material handling equipment, which is due for maintenance normally at least once per year, unless adverse working conditions dictate shorter periods.
- Inspections and repairs must be performed by competent persons or specialist workshops that use original spare parts. Inspections and repairs have to be recorded consecutively.

## Inspections

- Inspections are visual and functional and shall establish that the product has not been damaged by incorrect transport or storage. In addition check for damage, wear, corrosion or other deficiencies as well as completeness and function safety devices. Inspections are instigated by the user.
- Material handling products have to be cleaned prior to inspection. The cleaning procedure must not cause chemical damages (e.g. no acid – embrittlement) no incorrect temperature stress by e.g. flame cleaning or possible concealment of cracks due to excessive material abrasion (sand blasting). We shall be pleased to consult you in this respect!
- **Inspection of fork frame**  
The fork frame has to be checked regularly for obvious defects, deformations and cracks as well as wear and corrosion.
- **Inspection of control handle**  
The control handle must be checked regularly for obvious defects, deformations, cracks. Moreover, check screws for fixed seat.
- **Inspection of oil level**  
Check oil level every six months (Oil viscosity 30 Cst at 40° C). At ambient temperature around 0° C we recommend AVILUB RSL 22.
- **Inspection of lubrication and density**  
Bolts, axles and push rods should be cleaned and lubricated depending on application with e.g. Shell FD or comparable grease.
- The hydraulic unit has to be checked regularly for density.



## Load diagrams for residual carrying capacities

- Capacity restrictions start at a fork height  $h_3 = 2500$  mm (EGV PSH 14-45T: 2900 mm).

**Model EHH PS 12-25/12-29/12-35**

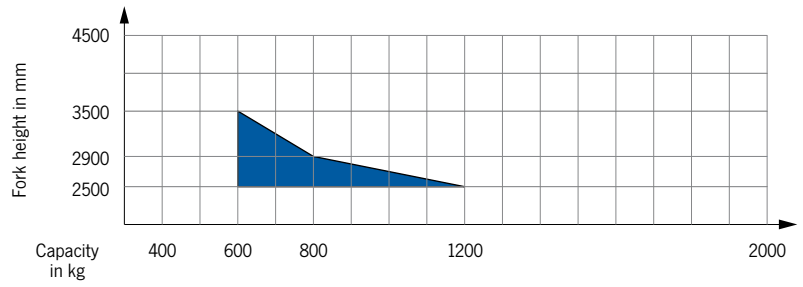

**Model EGV PSL 12-25/12-29/12-35**

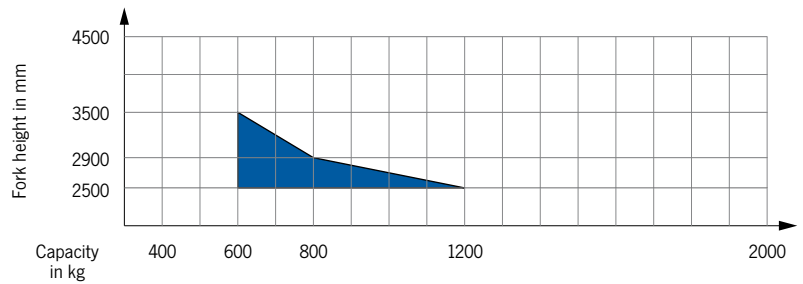

**Model EGV PSH 12-25/12-29/12-35**

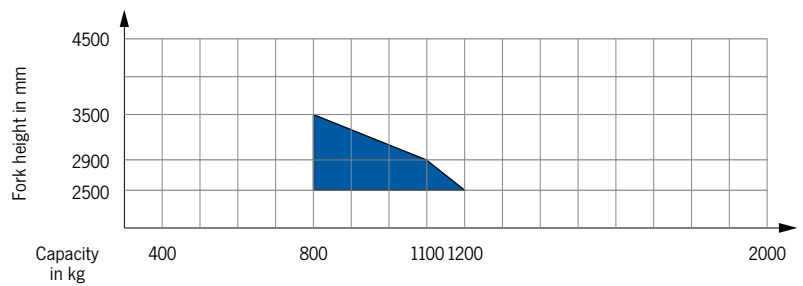

**Model EGV PSH 14-45T/14-50T**

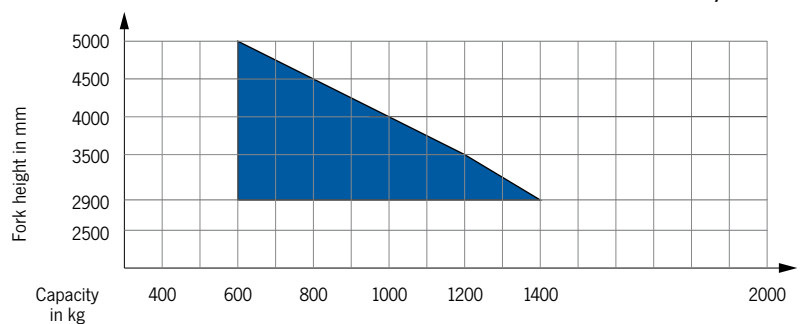

**Model EGV PSH 16-25/16-29/16-35**

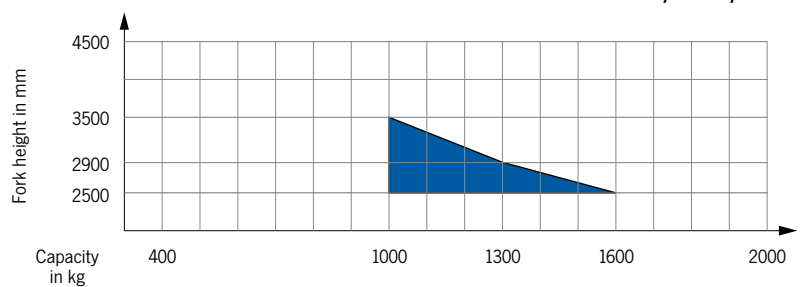

### Technical questionnaire for choosing a suitable material handling product

Company: \_\_\_\_\_

Date: \_\_\_\_\_

Contact: \_\_\_\_\_

e-Mail: \_\_\_\_\_

Phone: \_\_\_\_\_

Fax: \_\_\_\_\_

Capacity \_\_\_\_\_ kg

Fork height max. \_\_\_\_\_ mm

Free lift \_\_\_\_\_ mm

Required residual lifting capacity \_\_\_\_\_ mm

At fork height \_\_\_\_\_ mm

Headroom with mast retracted \_\_\_\_\_ mm

**Lifting**

- manual-hydraulic
- electric-hydraulic

**Drive**

- manual
- electric

**Transport and stacking of:**

- Palletised goods
- Long goods
- Loading lorries

Special requests

\_\_\_\_\_

\_\_\_\_\_

**Lengths of application per shift**

- up to 2 hours
- up to 4 hours
- up to 6 hours
- up to 8 hours

Shifts per day

\_\_\_\_\_

**Drivers platform**

- yes
- no



## Hand pallet truck model HU 26-115 TMt PROLINE MOTION

Capacity 2600 kg

For the professional transportation of palletised goods and box pallets under demanding conditions.

### Features

- Ergonomic safety control handle for one-hand operation of lifting, driving and lowering.
- Ergonomic designed control handle for safe handling.
- Low maintenance high performance hydraulic pump with hard chromium plated piston and pressure relief valve.
- Frame and forks in robust steel construction, adjustable connecting rods, especially hardened axles and the high quality powder coating ensure a long life expectancy.
- Apron with shock absorbing rubber buffer in Pfaff-design.
- Steering angle of 105 degree to each side for easy handling in confined spaces.
- Entry rollers facilitate entry into bottom boarded pallets.



Option: Parking brake



### Technical data model HU 26-115 TMt PROLINE MOTION

Model	HU 26-115 TMt	HU 26-115 TMt
Art.-No.	040009215	040009873
Capacity, kg	2600	2600
Load center c, mm	600	600
Weight, kg	86	86
Tyre type*	VG/PUR	PUR/PUR
Steering rollers, mm	200x50	200x50
Load rollers, mm	84x70	84x70
Number of wheels/load rollers	2/4	2/4
Stroke h3, mm	115	115
Height of control handle h14, mm	1200	1200
Fork height lowered h13, mm	85	85
Overall length L1, mm	1535	1535
Fork height s, mm	45	45
Fork width e, mm	160	160
Fork length l, mm	1150	1150
Outside dimension of forks b1, mm	540	540
Inside dimension of forks b3, mm	220	220
Ground clearance m1, mm	40	40
Aisle width pallet Ast, mm	1815	1815
Turning circle radius Wa, mm	1330	1330

\*PUR... Polyurethane, VG... Solid rubber

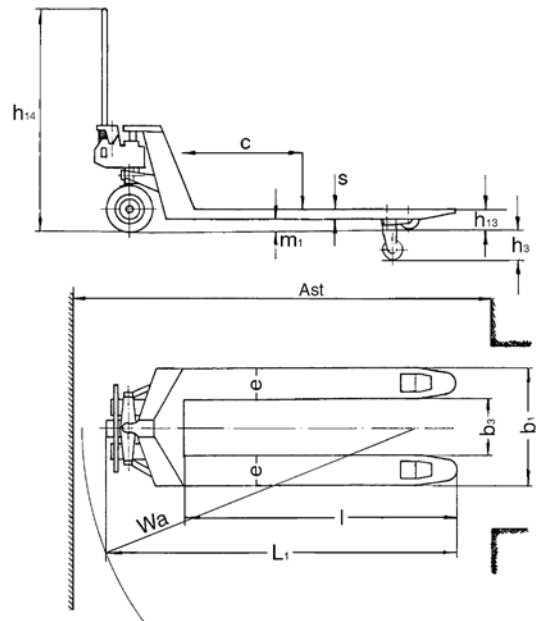

Hand pallet truck model HU 26-115 TMt PROLINE MOTION  
Hand pallet truck model HU 25-115 TS and ES SILVERLINE



**Hand pallet truck  
model HU 25-115 TS  
SILVERLINE**

**model HU 25-115 ES  
SILVERLINE**

Capacity 2500 kg

For the professional transportation of palletised goods and box pallets under demanding conditions.

**Features**

- Ergonomic safety control handle for one-hand operation of lifting, driving and lowering.
- Ergonomic rubber control handle for safe handling.
- Low maintenance hydraulic pump with hard chromium plated piston.
- Frame and forks in robust steel construction, adjustable connecting rods, especially hardened axles and the high quality powder coating ensure a long life expectancy.



Option: Parking brake

**Technical data model HU 25-115 TS SILVERLINE and model HU 25-115 ES SILVERLINE**

Model	HU 25-115 TS	HU 25-115 TS	HU 25-115 TS	HU 25-115 TS	HU 25-115 ES
Art.-No.	034527100	034527101	034527108	034527130	034527106
Capacity, kg	2500	2500	2500	2500	2500
Load center c, mm	600	600	600	600	600
Weight, kg	75	79	79	68	84
Tyre type*	VG/PA	VG/PUR	PUR/PUR	PA/PA	VG/PUR
Steering rollers, mm	200x50	200x50	200x50	200x50	200x50
Load rollers, mm	82x70	82x70	82x70	80x70	82x93
Number of wheels/load rollers	2/4	2/4	2/4	2/4	2/2
Stroke h3, mm	115	115	115	115	115
Height of control handle h14, mm	1200	1200	1200	1200	1200
Fork height lowered h13, mm	85	85	85	85	85
Overall length L1, mm	1535	1535	1535	1535	1535
Fork height s, mm	45	45	45	45	45
Fork width e, mm	160	160	160	160	160
Fork length l, mm	1150	1150	1150	1150	1150
Outside dimension of forks b1, mm	540	540	540	540	540
Inside dimension of forks b3, mm	220	220	220	220	220
Ground clearance m1, mm	40	40	40	40	40
Aisle width pallet Ast, mm	1815	1815	1815	1815	1815
Turning circle radius Wa, mm	1330	1330	1330	1330	1330

\*PA... Polyamide, PUR... Polyurethane, VG... Solid rubber



## Hand pallet truck with a wider loading width model HU 20-115 BTS SILVERLINE and model HU 25-115 BTS SILVERLINE

Capacity 2000 - 2500 kg

For the professional transportation of special pallets, e.g. brickyard pallets or american pallets.

### Features

- Ergonomic safety control handle for one-hand operation of lifting, driving and lowering.
- Ergonomic rubber control handle for safe handling.
- Low maintenance high performance hydraulic pump with hard chromium plated piston and pressure relief valve.
- Frame and forks in robust steel construction, adjustable connecting rods, especially hardened axles and the high quality powder coating ensure a long life expectancy.
- Increased fork width for the transport of particularly broad and special pallets.
- Steering angle of 105 degree to each side for easy handling in confined spaces.



Option: Parking brake

### Technical data model HU 20-115 BTS and model HU 25-115 BTS

Model	HU 20-115 BTS	HU 25-115 BTS
Art.-No.	034527132	034527105
Capacity, kg	2000	2500
Weight, kg	86	88
Tyre type*	VG/PUR	PUR/PUR
Steering rollers, mm	200 x 50	200 x 50
Load rollers, mm	82 x 70	82 x 70
Stroke h3, mm	115	115
Height of control handle h14, mm	1200	1200
Fork height lowered h13, mm	85	85
Fork width e, mm	160	160
Fork length l, mm	1150	1150
Outside dimension of forks b1, mm	850	685

\*PUR... Polyurethane, VG... Solid rubber

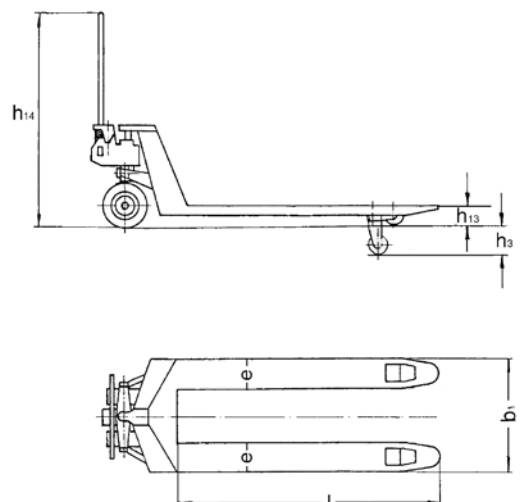

## Hand pallet truck with low height forks model HU 15-115 FTP PROLINE

Capacity 1500 kg

For the professional transportation of particularly low pallets.

### Features

- Ergonomic safety control handle for one-hand operation of lifting, driving and lowering.
- Ergonomic rubber control handle for safe handling.
- Low maintenance high performance hydraulic pump with hard chromium plated piston and pressure relief valve.
- Frame and forks in robust steel construction, adjustable connecting rods, especially hardened axles and the high quality powder coating ensure a long life expectancy.
- Pallet entry height of only 51 mm for easy entry in particularly low pallets.
- Steering angle of 105 degree to each side for easy handling in confined spaces.



### Technical data model HU 15-115 FTP

Model	HU 15-115 FTP
Art.-No.	034527124
Capacity, kg	1500
Weight, kg	84
Tyre type*	PUR/PA
Steering rollers, mm	180x50
Load rollers, mm	50x70
Stroke h3, mm	115
Height of control handle h14, mm	1200
Fork height lowered h13, mm	51
Fork width e, mm	160
Fork length l, mm	1150
Outside dimension of forks b1, mm	540

\*PUR... Polyurethane, PA... Polyamide

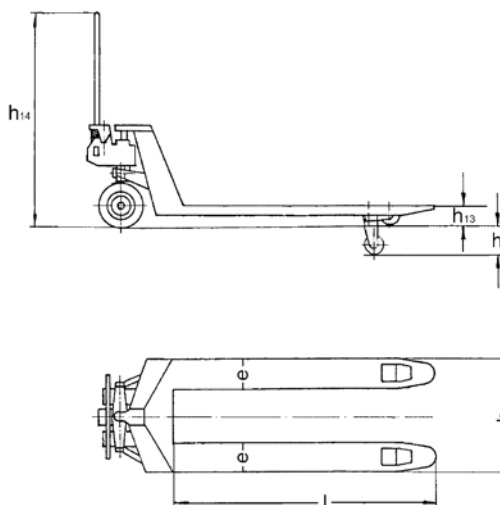

## Hand pallet truck PROLINE with short forks

Capacity 2500 kg

For the professional transportation of short palletised goods and box pallets under demanding conditions.

### Features

- Ergonomic safety control handle for one-hand operation of lifting, driving and lowering.
- Ergonomic rubber control handle for safe handling.
- Low maintenance high performance hydraulic pump with hard chromium plated piston and pressure relief valve.
- Frame and forks in robust steel construction, adjustable connecting rods, especially hardened axles and the high quality powder coating ensure a long life expectancy.
- Fork lengths from 800 up to 1000 mm for transportation of small loads.
- Steering angle of 105 degree to each side for easy handling in confined spaces.



### Technical data hand pallet truck PROLINE with short forks

Model	HU 25-80 EP	HU 25-90 EP	HU 25-100 EP	HU 25-80 TP	HU 25-90 TP	HU 25-100 TP
Art.-No.	034527150	034527151	034527152	034527153	034527154	034527155
Capacity, kg	2500	2500	2500	2500	2500	2500
Weight, kg	67	72	77	71	76	81
Tyre type*	VG/PUR	VG/PUR	VG/PUR	VG/PUR	VG/PUR	VG/PUR
Steering rollers, mm	200x50	200x50	200x50	200x50	200x50	200x50
Load rollers, mm	82x93	82x93	82x93	82x70	82x70	82x70
Stroke h3, mm	115	115	115	115	115	115
Height of control handle h14, mm	1200	1200	1200	1200	1200	1200
Fork height lowered h13, mm	85	85	85	85	85	85
Fork width e, mm	160	160	160	160	160	160
Fork length l, mm	800	900	1000	800	900	1000
Outside dimension of forks b1, mm	540	540	540	540	540	540

\*PUR... Polyurethane, VG... Solid rubber

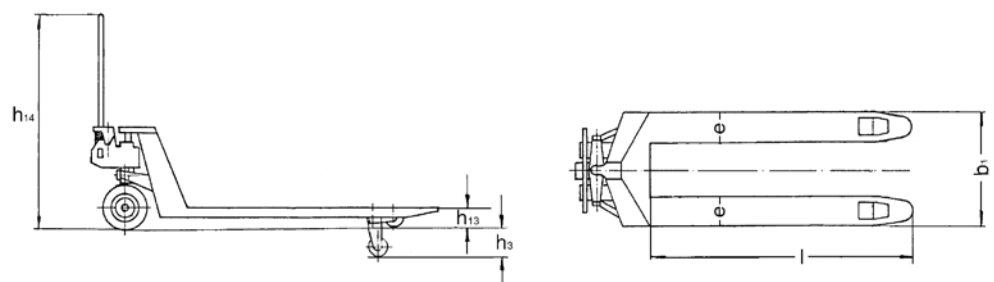

## Hand pallet truck PROLINE for heavy loads

Capacity 3000 - 5000 kg

For the professional transportation of heavy loads.

### Features

- Ergonomic safety control handle for one-hand operation of lifting, driving and lowering.
- Ergonomic rubber control handle for safe handling (only model HU 30-115 TP).
- Low maintenance high performance hydraulic pump with hard chromium plated piston and pressure relief valve.
- Frame and forks in robust steel construction, adjustable connecting rods, especially hardened axles and the high quality powder coating ensure a long life expectancy.



### Technical data hand pallet truck PROLINE for heavy loads

Model	HU 30-115 TP	HU 50-115 TP	HU 50-200 TP
Art.-No.	034527128	034527058	034527056
Capacity, kg	3000	5000	5000
Weight, kg	95	240	300
Tyre type*	PUR/PUR	steel/steel	steel/steel
Steering rollers, mm	200x50	200x50	200x50
Load rollers, mm	82x70	82x80	82x80
Stroke h3, mm	115	110	110
Height of control handle h14, mm	1200	1220	1220
Fork height lowered h13, mm	85	90	105
Fork width e, mm	160	210	210
Fork length l, mm	1150	1150	2000
Outside dimension of forks b1, mm	540	580	700

\*PUR... Polyurethane

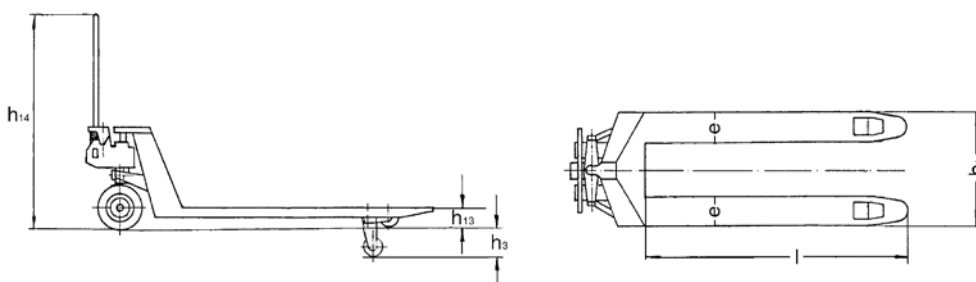

## Hand pallet truck PROLINE with extended forks

Capacity 1500 - 2500 kg

For the professional transportation of long palletised goods and box pallets under demanding conditions.

### Features

- Ergonomic safety control handle for one-hand operation of lifting, driving and lowering.
- Ergonomic rubber control handle for safe handling.
- Low maintenance high performance hydraulic pump with hard chromium plated piston and pressure relief valve.
- Frame and forks in robust steel construction, adjustable connecting rods, especially hardened axles and the high quality powder coating ensure a long life expectancy.
- Fork lengths from 1300 up to 2000 mm for transportation of long and bulky loads.
- Steering angle of 105 degree to each side for easy handling in confined spaces.



Option: Parking brake

### Technical data hand pallet truck PROLINE with extended forks

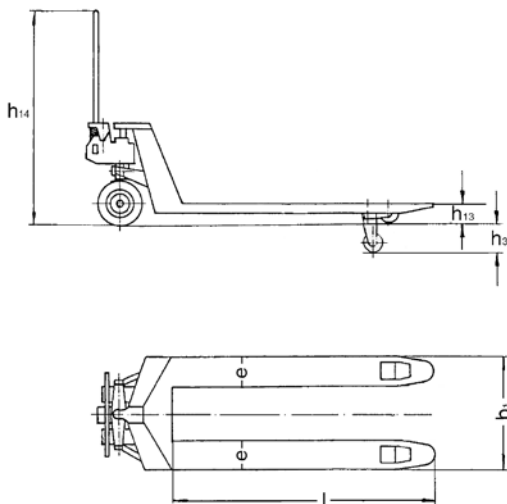

Model	HU 25-130 TP	HU 20-150 TP	HU 15-180 TP	HU 15-200 TP
Art.-No.	034527160	034527161	034527162	034527163
Capacity, kg	2500	2000	1500	1500
Weight, kg	96	106	116	126
Tyre type*	VG/PUR	VG/PUR	VG/PUR	VG/PUR
Steering rollers, mm	200x50	200x50	200x50	200x50
Load rollers, mm	82x70	82x70	82x70	82x70
Stroke h3, mm	115	115	115	115
Height of control handle h14, mm	1200	1200	1200	1200
Fork height lowered h13, mm	85	85	85	85
Fork width e, mm	160	160	160	160
Fork length l, mm	1300	1500	1800	2000
Outside dimension of forks b1, mm	540	540	540	540

\*PUR... Polyurethane, VG... Solid rubber Other versions available on request

## Hand pallet truck PROLINE with extended forks and increased capacity

Capacity 2000 - 3500 kg

For the professional transportation of long palletised goods and box pallets under demanding conditions.

### Features

- Ergonomic safety control handle for one-hand operation of lifting, driving and lowering.
- Ergonomic rubber control handle for safe handling.
- Low maintenance high performance hydraulic pump with hard chromium plated piston and pressure relief valve.
- Frame and forks in robust steel construction, adjustable connecting rods, especially hardened axles and the high quality powder coating ensure a long life expectancy.
- Fork lengths from 1500 up to 3000 mm for transportation of long goods.
- Steering angle of 105 degree to each side for easy handling in confined spaces.



**With extended forks up to 3000 mm and increased capacity up to 3500 kg.**

### Technical data hand pallet truck PROLINE with extended forks and increased capacity

Model	HU 20-180 TP	HU 20-200 TP	HU 20-250 TP	HU 20-300 TP	HU 30-150 TP	HU 30-180 TP	HU 35-200 TP
Art.-No.	034527200	034527201	034527202	034527203	034527204	034527205	034527206
Capacity, kg	2000	2000	2000	2000	3000	3000	3500
Weight, kg	108	129	275	316	121	139	148
Tyre type*	VG/PUR	VG/PUR	PUR/PUR	PUR/PUR	PUR/PUR	PUR/PUR	PUR/PUR
Steering rollers, mm	200x50	200x50	200x50	200x50	200x50	200x50	200x50
Load rollers, mm	82x70	82x70	82x70	82x70	82x70	82x70	82x70
Stroke h3, mm	115	115	115	115	115	115	115
Height of control handle h14, mm	1200	1200	1200	1200	1200	1200	1200
Fork height lowered h13, mm	85	85	85	85	85	85	85
Fork width e, mm	160	160	170	170	160	170	170
Fork length l, mm	1800	2000	2500	3000	1500	1800	2000
Outside dimension of forks b1, mm	540	540	550	550	540	550	550

\*PUR... Polyurethane, VG... Solid rubber

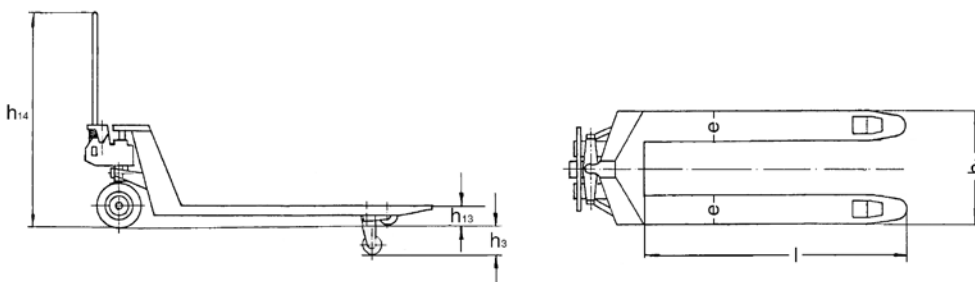



## Hand pallet truck with quick-lift model 20-115 QLTP PROLINE

Capacity 2000 kg

For quick lifting and professional transportation of palletised goods and box pallets under demanding conditions.

Features

- Ergonomic safety control handle for one-hand operation of lifting, driving and lowering.
- Ergonomic rubber control handle for safe handling.
- Low maintenance high performance hydraulic pump with hard chromium plated piston and pressure relief valve.
- Quick-lift function for loads up to 200 kg for quick lifting of the load.
- Frame and forks in robust steel construction, adjustable connecting rods, especially hardened axles and the high quality powder coating ensure a long life expectancy.
- Steering angle of 105 degree to each side for easy handling in confined spaces.

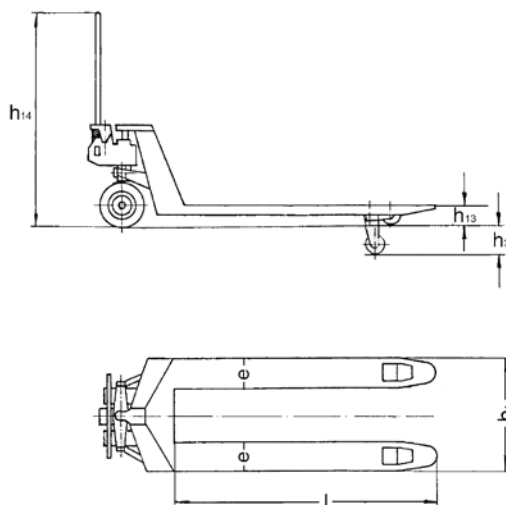

### Technical data model 20-115 QLTP

Model	20-115 QLTP
Art.-No.	034527125
Capacity, kg	2000
Weight, kg	86
Tyre type*	VG/PUR
Steering rollers, mm	200x50
Load rollers, mm	82x70
Stroke h3, mm	115
Height of control handle h14, mm	1200
Fork height lowered h13, mm	85
Fork width e, mm	160
Fork length l, mm	1150
Outside dimension of forks b1, mm	540

\*PUR... Polyurethane, VG... Solid rubber

## Hand pallet truck with parking brake model HU 25 FBTP PROLINE

Capacity 2500 kg

For the professional transportation of palletised goods and box pallets, on ramps, ascending slopes and on lorries.

### Features

- Ergonomic safety control handle for one-hand operation of lifting, driving and lowering.
- Ergonomic rubber control handle for safe handling.
- Driving and park brake comfortably operated from the control handle.
- Low maintenance high performance hydraulic pump with hard chromium plated piston and pressure relief valve.
- Frame and forks in robust steel construction, adjustable connecting rods, especially hardened axles and the high quality powder coating ensure a long life expectancy.
- Steering angle of 105 degree to each side for easy handling in confined spaces.



### Technical data model 25-115 FBTP

Model	HU 25-115 FBTP
Art.-No.	034527135
Capacity, kg	2500
Weight, kg	86
Tyre type*	VG/PUR
Steering rollers, mm	200x50
Load rollers, mm	82x70
Stroke h3, mm	115
Height of control handle h14, mm	1200
Fork height lowered h13, mm	85
Fork width e, mm	160
Fork length l, mm	1150
Outside dimension of forks b1, mm	540

\*PUR... Polyurethane, VG... Solid rubber

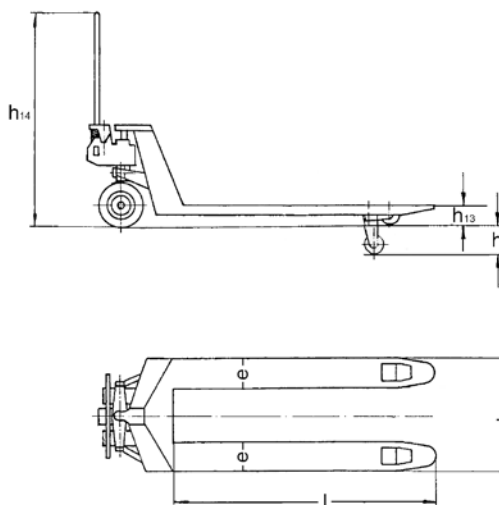



## Hand pallet truck, stainless steel version model HU 20-115 VATP PROLINE

Capacity 2000 kg

For the professional transportation of palletised goods in corrosive areas.

### Features

- Ergonomic safety control handle for one-hand operation of lifting, driving and lowering.
- Low maintenance high performance hydraulic pump with hard chromium plated piston and pressure relief valve.  
Hydraulic unit made of V4A – 316 stainless steel.
- Frame, adjustable connecting rods, bolts and the torsion tube are made of high quality V4A – 316 stainless steel.
- Steering angle of 105 degree to each side for easy handling in confined spaces.

**The operator is responsible for an analysis of the working conditions in order to assess the suitability of the hand pallet truck.**

### Technical data model HU 20-115 VATP

Model	HU 20-115 VATP
Art.-No.	040005740
Capacity, kg	2000
Weight, kg	86
Tyre type*	PA/PA
Steering rollers, mm	200 x 50
Load rollers, mm	82 x 70
Stroke h3, mm	115
Height of control handle h14, mm	1200
Fork height lowered h13, mm	85
Fork width e, mm	160
Fork length l, mm	1150
Outside dimension of forks b1, mm	540

\*PA... Polyamide

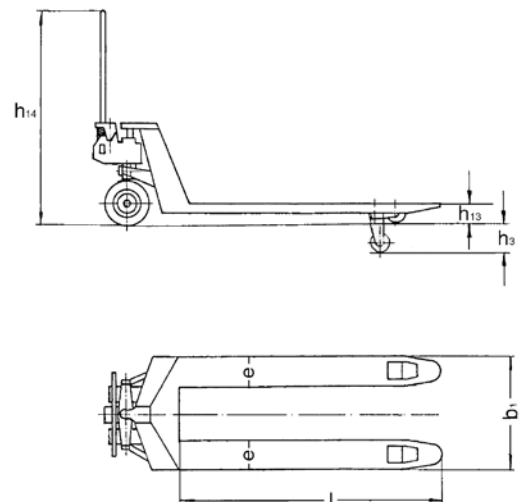

**Hand pallet truck,  
galvanized version  
model HU 25-115 GAL  
PROLINE**

Capacity 2500 kg

For the professional transportation of palletised goods in corrosive areas.

**Features**

- Ergonomic safety control handle for one-hand operation of lifting, driving and lowering.
- Low maintenance high performance hydraulic pump with hard chromium plated piston and pressure relief valve.
- Galvanized frame with a layer of 100 µm, cold galvanized control handle and hydraulic system, stainless steel running gear, ball bearings and axles ensure high chemical resistance.
- Steering angle of 105 degree to each side for easy handling in confined spaces.



**!** The operator is responsible for an analysis of the working conditions in order to assess the suitability of the hand pallet truck.

**Technical data model HU 25-115 GAL**

Model	HU 25-115 GAL
Art.-No.	034527170
Capacity, kg	2500
Weight, kg	86
Tyre type*	PA/PA
Steering rollers, mm	200x50
Load rollers, mm	82x70
Stroke h3, mm	115
Height of control handle h14, mm	1200
Fork height lowered h13, mm	85
Fork width e, mm	160
Fork length l, mm	1150
Outside dimension of forks b1, mm	540

\*PA... Polyamide

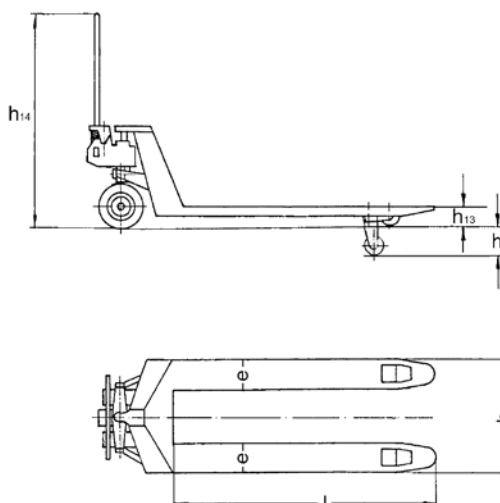



## Hand pallet truck with weighing system model HU W-20 SL SILVERLINE

### Capacity 2000 kg

For transportation and weighing of palletised goods and box pallets. For simple weighing jobs and a rough calculation of total weights, e.g. when loading lorries.

### Features

- The basic truck is the model Silverline HU 25-115.
- Ergonomic safety control handle for one-hand operation of lifting, driving and lowering.
- Ergonomic rubber control handle for safe handling.
- Measuring range from 0 up to 2000 kg in 5 kg steps.
- Easy to read LCD display.
- Accuracy:
  - 0 - 500 kg → +/- 10 kg
  - 500 - 1000 kg → +/- 20 kg
  - 1000 - 2000 kg → +/- 30 kg
- The weighing system is calibrated at the factory.

### Scope of delivery

- 2 x 1.5 V AA batteries (sufficient for approx. 3000 weighing operations)

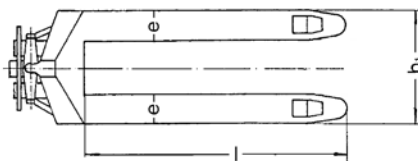
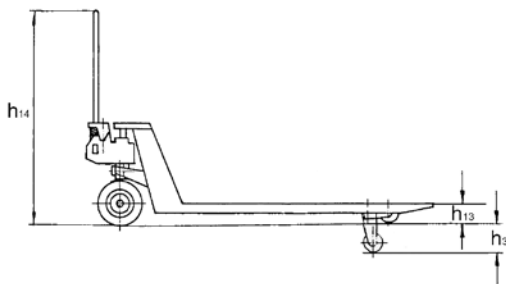

**! Weighing system also available for hand pallet trucks with special lengths on request.**



### Technical data model HU W-20 SL

Model	HU W 20 SL
Art.-No.	040048616
Capacity, kg	2000
Load center c, mm	600
Weight, kg	76
Tyre type*	PUR/PUR
Steering rollers D, mm	200x50
Load rollers D1, mm	82x70
Number of wheels/load rollers	2/4
Stroke h2, mm	115
Lifting height h3, mm	200
Height of control handle h14, mm	1200
Fork height lowered h13, mm	85
Overall length L1, mm	1535
Fork height s, mm	45
Fork width e, mm	160
Fork length l, mm	1150
Outside dimension of forks b1, mm	540
Ground clearance m1, mm	40
Turning circle radius, mm	1330
Ambient temperature	-5° C up to +40° C

\*PUR... Polyurethane

## Hand pallet truck with weighing system model HU W-20 S SILVERLINE

Capacity 2000 kg

For transportation and weighing of palletised goods and box pallets. For simple weighing jobs and a rough calculation of total weights, e.g. when loading lorries.

### Features

- Ergonomic safety control handle for one-hand operation of lifting, driving and lowering.
- Ergonomic rubber control handle for safe handling.
- Measuring range from 0 up to 2000 kg in 1 kg steps.
- Easy to read LCD display.
- Accuracy +/- 0.25% of the end value.
- The readings start at 1.0 kg.
- The weighing system is calibrated at the factory.
- The system is designed for simple weighing jobs, such as batching or filling processes.
- Low maintenance hydraulic pump with hard chromium plated piston and pressure relief valve.
- Frame and forks in robust steel construction, adjustable connecting rods, especially hardened axles and the high quality powder coating ensure a long life expectancy.
- Steering angle of 105 degree to each side for easy handling in confined spaces.



### Scope of delivery

- 4x 1.5 V batteries

### Technical data model HU W-20 S

Model	HU W 20 S
Art.-No.	040016431
Capacity, kg	2000
Load center c, mm	600
Weight, kg	129
Tyre type*	PUR/PUR
Steering rollers D, mm	180x50
Load rollers D1, mm	74x70
Number of wheels/load rollers	2/4
Stroke h2, mm	110
Lifting height h3, mm	195
Height of control handle h14, mm	1210
Fork height lowered h13, mm	85
Overall length L1, mm	1580
Fork height s, mm	50
Fork width e, mm	180
Fork length l, mm	1150
Outside dimension of forks b1, mm	570
Inside dimension of forks b3, mm	210
Ground clearance m1, mm	35
Turning circle radius, mm	1330
Ambient temperature	-10° C up to +40° C

\*PUR... Polyurethane

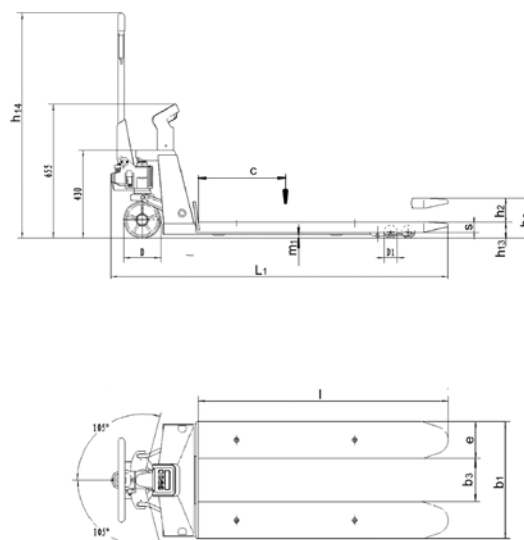

**Hand pallet truck  
with weighing system  
model HU PW 25 T  
PROLINE**

**Capacity 2500 kg**

Fitted with four high quality load cells the hand pallet truck becomes a mobile weighing system. Special calibration on request. The robust construction of the basic truck and high quality electronics make demanding applications possible.

**Features**

- LED display (83plus)\* has 6 characters, the characters are 20 mm in height.
- Weighing operations: Tare (gross/net), count, add, automatic return to zero.
- Accuracy  $\pm 0.1\%$  of the end value.
- Pallet entry height of only 85 mm.
- The battery capacity provides for around 30 operating hours.
- The weighing system is calibrated at the factory.

<b>Multi range scale</b>	
<b>Weight</b>	<b>Measuring steps</b>
0 - 500 kg	0.2 kg
500 - 1000 kg	0.5 kg
1000 - 2500 kg	1.0 kg

**Options**

- Special calibration of the measured value (Multi-range scale).
- With printer
- Change setting of partition

**Scope of delivery**

- Battery and battery charger



\*Made by RHEWA



## Technical data model HU PW 25 T PROLINE

Model	HU PW 25 T	HU PW 25 TR - 83plus with printer
Art.-No.	21220600	21220601
Capacity Q, kg	2500	2500
Load center c, mm	600	600
Load distance x, mm	850	850
Wheelbase y, mm	1205	1205
Weight, kg	145	145
Tyre type**	PUR/PA	PUR/PA
Steering rollers, mm	194x50	194x50
Load rollers, mm	80x63	80x63
Number of wheels/load rollers	2/4	2/4
Stroke h3, mm	115	115
Height of control handle max. h14, mm	1230	1230
Fork height lowered h13, mm	85	85
Overall length l1, mm	1525	1525
Length incl. apron l2, mm	375	375
Overall width b1/b2, mm	535	535
Fork height s, mm	60	60
Fork width e, mm	165	165
Fork length l, mm	1140	1140
Outside dimension of forks b5, mm	535	535
Ground clearance, wheelbase centre m2, mm	20	20
Aisle width pallet Ast, mm	1832	1832
Turning circle radius Wa, mm	1367	1367

\*\*PA ... Polyamide, PUR... Polyurethane

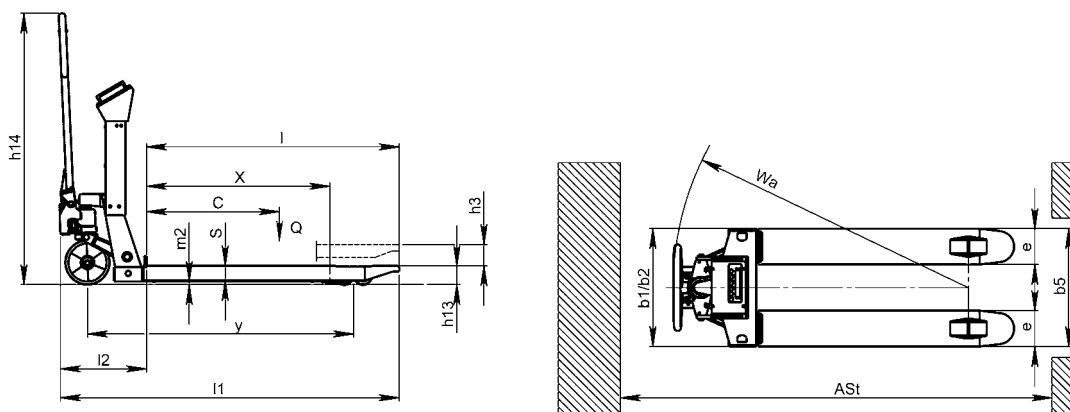

LED-display 83plus



Option: with printer



## Scissor pallet truck with manual-hydraulic lift model HU HS 10 A

Capacity 1000 kg,  
fork height max. 800 mm

A combination of hand pallet truck and elevating platform for the transport and raising of palletised loads to various departments.

### Features

- Safety control handle with the functions:
  - Quick-lift – lifting – lowering –
- Lowering speed can be finely metered for sensitive lowering of the load.
- One-stage hydraulic for increased robustness.
- Quick-lift for loads up to 250 kg.
- Overload protection by pressure relief valve.
- Safety supports guarantee sure standing when the forks are raised.
- Low noise and smooth running with standard tyres: steer rollers and load rollers – polyurethane.

### Technical data model HU HS 10 A

Model	HU HS 10 A
Art.-No.	26600010
Capacity Q, kg	1000
Load center c, mm	600
Weight, kg	140
Tyre type**	PUR/PUR
Steering rollers, mm	200 x 50
Load rollers, mm	78 x 60
Number of wheels/load rollers	2/2
Stroke h3, mm	715
Height of control handle max. h14, mm	1235
Fork height lowered h13, mm	85
Overall length l1, mm	1650
Overall width b1/b2, mm	540
Fork height s, mm	50
Fork width e, mm	160
Fork length l, mm	1150
Outside dimension of forks b5, mm	540
Ground clearance, wheelbase centre m2, mm	35
Aisle width pallet Ast, mm	1900
Turning circle radius Wa, mm	1440

\*\*PUR ... Polyurethane

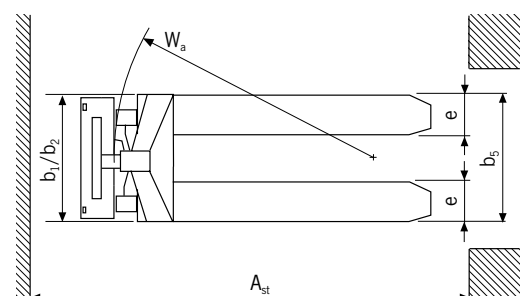
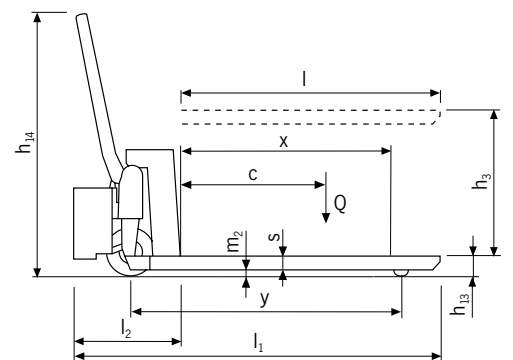

## Scissor pallet truck with electric-hydraulic lift model HU ES 10A

Capacity 1000 kg,  
fork height max. 800 mm

The model HU ES 10 A increases the usefulness of the HU HS 10 A by saving operating time for demanding applications with frequent lifting and lowering operations.

### Features

- Ergonomic control button for the hydraulic unit fitted in the handle.
- In case of a battery failure the manual use of lifting and lowering is still guaranteed.
- Quick electric-hydraulic lifting of the load, pressure relief valve protects against overloading.
- Low noise and smooth running due to polyurethane steering and load rollers as standard.
- Additional tilting protection for the load rollers.

### Scope of delivery

- Battery and battery charger

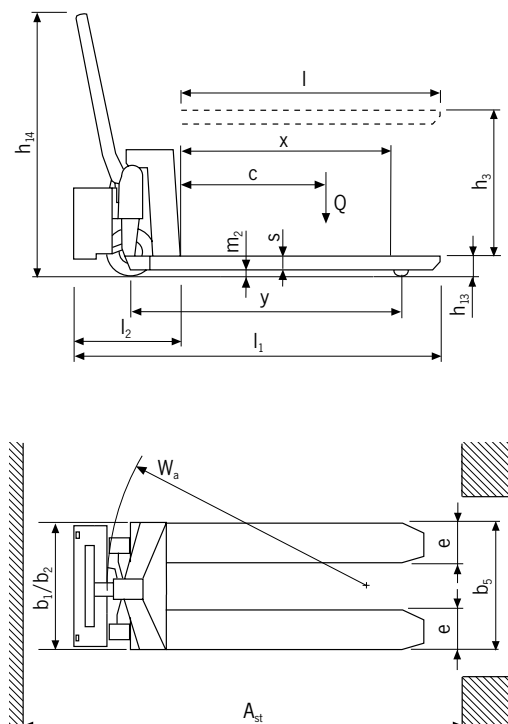

### Technical data model HU ES 10A

Model	HU ES 10A
Art.-No.	26900010
Capacity Q, kg	1000
Load center c, mm	600
Weight, kg	167
Tyre type**	PUR/PUR
Steering rollers, mm	180x50
Load rollers, mm	75x50
Number of wheels/load rollers	2/2
Stroke h3, mm	715
Height of control handle max. h14, mm	1230
Fork height lowered h13, mm	85
Overall length l1, mm	1740
Overall width b1/b2, mm	540
Fork height s, mm	50
Fork width e, mm	160
Fork length l, mm	1170
Outside dimension of forks b5, mm	540
Ground clearance, wheelbase centre m2, mm	35
Aisle width pallet Ast, mm	1990
Turning circle radius Wa, mm	1450
Battery charger, V/A	220/8
Battery voltage, capacity K5, V/Ah	12/65

\*\*PUR... Polyurethane

## Hand pallet truck with electric drive model JOKER CLASSIC PROLINE

Capacity 1500 kg

Ideal for the internal application of transporting palletised goods on even ground, covering short distances.

Compact dimensions and easy handling turn the JOKER CLASSIC into a real alternative to a standard hand pallet truck. An electric control and the powerful motor ensure a finely metered and rapid start.

A high performance hydraulic pump guarantees a smooth lifting of the load.

### Features

- Safety control handle with the functions: lifting, driving and lowering.
- Lowering speed can be finely metered for sensitive lowering of the load.
- Pressure relief valve as protection against overload.
- Maintenance-free motor and batteries.
- Quick charging at every 230V power socket due to integrated battery charger.
- Strong DC middle-motor with electromagnetic brake.
- Battery charge indicator
- Entry rollers facilitate entry into bottom-boarded pallets.

### Scope of delivery

- Maintenance free lead-batteries 2x 12V/40Ah and integrated battery charger.



Technical data model JOKER CLASSIC PROLINE

Model	JOKER CLASSIC
Art.-No.	040031013
Actuation	electric
Capacity, kg	1500
Load center c, mm	600
Weight (with battery), kg	160
Tyre type**	PUR+PUR/PUR
Steering rollers, mm	220x70+80x70
Load rollers, mm	50x30
Number of wheels/load rollers (x=driven)	2+1x/4
Stroke h3, mm	115
Height of control handle max. h14, mm	1310
Fork height lowered h13, mm	85
Overall length l1, mm	1645
Overall width b1, mm	540
Fork height s, mm	48
Fork width e, mm	160
Fork length l, mm	1150
Outside dimension of forks b5, mm	540
Ground clearance m2, mm	37
Aisle width pallet Ast, mm	1895
Turning circle radius Wa, mm	1430
Steering angle, degrees	180
Actuation	manual-hydraulic
Travel speed with/without load, km/h	3/3.3
Lowering speed with/without load, m/s	metered
Gradient with/without load, %	5/8
Service brake	electric
Drive motor rating S2 60 min, kW	0.5
Battery*	starter
Battery voltage, V/Ah	2 x 12/40
Battery weight, kg	20
Type of control	impulse

\*PUR... Polyurethane

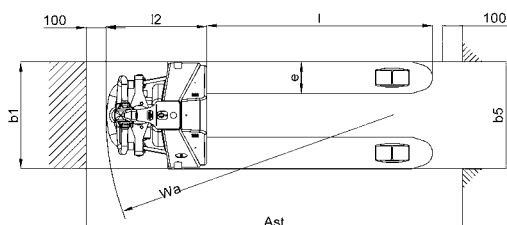
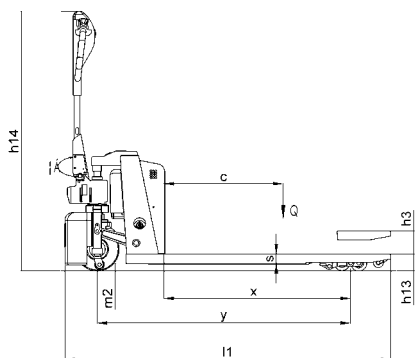



Technical data model EGU PS 14

Model	EGU PS 14 S	EGU PS 14 P
Art.-No.	040046050	040040500
Actuation	electric	electric
Operation	pedestrian	pedestrian
Capacity, kg	1400	1400
Load center c, mm	600	600
Wheelbase Y, mm	1195	1195
Weight (with battery), kg	203	246
Tyre type*	VG/PUR	VG/PUR
Steering rollers l x d, mm	250x76+100x40	250x76+100x40
Load rollers l x d, mm	82x80	82x80
Number of wheels/load rollers (x=driven)	2+1x/2	2+1x/2
Stroke h3, mm	115	115
Fork height max. h15, mm	200	200
Height of control handle max. h14, mm	1241	1241
Fork height lowered h13, mm	85	85
Overall length L1, mm	1650	1650
Length incl. apron L2, mm	500	500
Overall width B, mm	720	720
Fork height s, mm	50	50
Fork width e, mm	150	150
Fork length l, mm	1150	1150
Outside dimension of forks b1, mm	525	525
Clearance fork tip-roller X	215	215
Aisle width pallet Ast, mm	1900	1900
Turning circle radius Wa, mm	1435	1435
Travel speed with/without load, km/h	4.5/4.7	4.5/4.7
Lifting speed with/without load, m/s	0.02/0.03	0.02/0.03
Lowering speed with/without load, m/s	0.04	0.04
Gradient with/without load, %	5/10	5/10
Service brake	electric	electric
Drive motor rating, kW	0.7	0.7
Hoist motor rating, kW	0.4	0.4
Battery	starter	traction
Battery voltage, capacity at 20 h, V/Ah	24/74	24/132
Type of control	impulse	impulse

\*PUR... Polyurethane, VG... Solid rubber

Electric pallet truck model EGU PS 14

Capacity 1400 kg

Electrical drive, electrical lifting

Ideal unit for working on ramps or taking along on a lorry.

Features

- Multifunctional control handle for easy handling. The electric pallet lift truck will automatically be slowed down if the control handle is no longer in the users hand.
- Reliable impulse control for stepless regulation of driving speed.
- Slow moving function at upright handle position for the use in confined spaces.
- Battery size depends on the type of application.
- Anti crush safety device on handle.

Options

- Tandem rollers

Scope of delivery

- Battery and battery charger included



## Electric pallet truck model EGU PS 20

Capacity 2000 kg

Electrical drive, electrical lifting

Ideal unit for working on ramps or taking along on a lorry.

### Features

- Multifunctional control handle for easy handling. The electric pallet lift truck will automatically be slowed down if the control handle is no longer in the users hand.
- Reliable impulse control for stepless regulation of driving speed.
- Slow moving function at upright handle position for the use in confined spaces.
- Battery size depends on the type of application.
- Anti crush safety device on handle.

### Options

- Tandem rollers



**Battery and battery charger are to be ordered separately.**

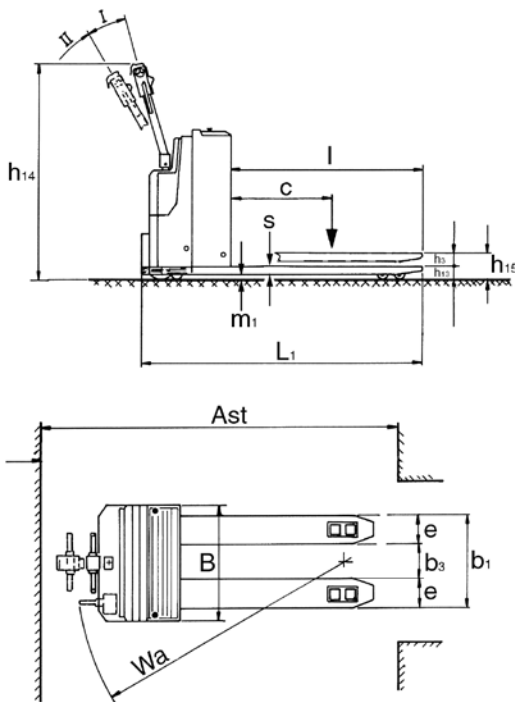

### Technical data model EGU PS 20

Model	EGU PS 20
Art.-No.	040046842
Actuation	electric
Operation	pedestrian
Capacity, kg	2000
Load center c, mm	600
Wheelbase Y, mm	1373
Weight (with battery), kg	520
Tyre type*	PUR/PUR
Steering rollers l x d, mm	230 x 75 + 100 x 40
Load rollers l x d, mm	85 x 90
Number of wheels/load rollers (x=driven)	2+1x/2
Stroke h3, mm	115
Fork height max. h15, mm	200
Height of control handle max. h14, mm	1320
Fork height lowered h13, mm	85
Overall length L1, mm	1715
Length incl. apron L2, mm	567
Overall width B, mm	716
Fork height s, mm	55
Fork width e, mm	170
Fork length l, mm	1150
Outside dimension of forks b1, mm	550
Clearance fork tip-roller X	215
Aisle width pallet Ast, mm	2000
Turning circle radius Wa, mm	1575
Travel speed with/without load, km/h	6.0/6.0
Lifting speed with/without load, m/s	0.04/0.05
Lowering speed with/without load, m/s	0.05/0.04
Gradient with/without load, %	10/20
Service brake	electric
Drive motor rating, kW	1.2
Hoist motor rating, kW	2.2
Battery**	Pzs
Battery voltage, capacity at 20 h, V/Ah	24V/180-230 Ah
Type of control	impulse

\*PUR... Polyurethane

\*\*PzS... traction battery





## Hand stacker model HG

Capacity 300 and 500 kg

Ideal for the occasional, internal application of stacking and transporting of palletised goods.

### Features

- Manual winch for exact positioning of the height.
- Handlebar for easy operation.
- C-profile mast with maintenance free pulley and guide rollers with ball bearings.
- Steering roller with brake for safe parking of the hand stacker.

### Technical data model HG

Model	HG 0315	HG 0515
Art.-No.	034518016	034518017
Capacity, kg	300	500
Load center c, mm	400	600
Wheelbase y, mm	850	1050
Weight, kg	80	90
Tyre type*	PA/PA	PA/PA
Steering rollers, mm	125x40	125x40
Load rollers, mm	75x30	75x30
Number of wheels/load rollers	2/2	2/2
Height, mast retracted h1, mm	1840	1840
Free lift h2, mm	1410	1410
Stroke h3, mm	1410	1410
Height, mast extended h4, mm	1840	1840
Lifting height max. h3+h13, mm	1500	1500
Fork height lowered h13, mm	90	90
Overall length L1, mm	1020	1320
Length incl. apron L2, mm	362	362
Overall width B, mm	710	710
Fork height s, mm	50	50
Fork width e, mm	160	160
Fork length l, mm	600	900
Outside dimension of forks b1, mm	580	580
Ground clearance m1, mm	30	30
Turning circle radius Wa, mm	855	1155
Lift per one crank rotation with/without load, mm	25	25

\*PA... Polyamide

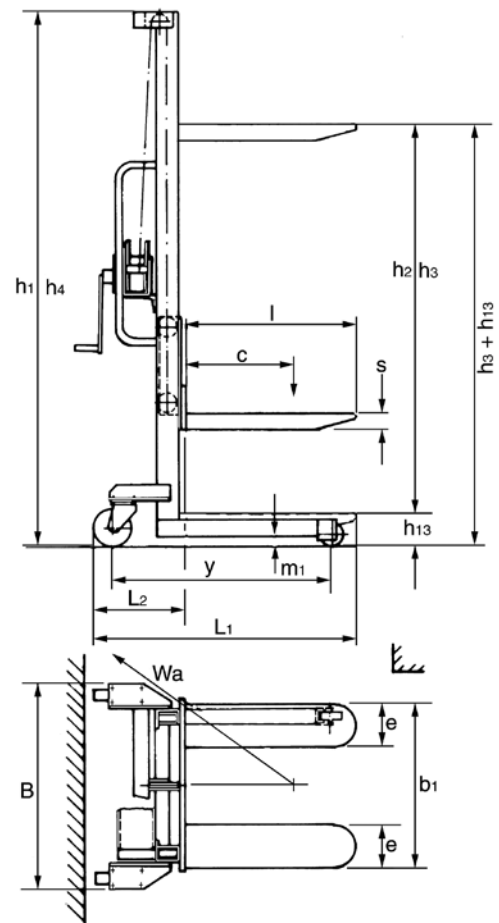

## Manual drive stacker with manual-hydraulic lift model HV 0516

Capacity 500 kg

Ideal for the occasional, internal application of stacking and transporting of palletised goods, loading and unloading of shelves and lorries.

### Features

- Ergonomic safety control handle for one-hand operation of lifting, driving and lowering.
- Handlebars for easy operation.
- Lowering speed can be finely metered for sensitive lowering of the load.
- Single-acting hand pump with increased lift per handle stroke.
- Robust mast construction with hard chromium plated piston.
- Steering roller with brake for safe parking of the hand stacker.

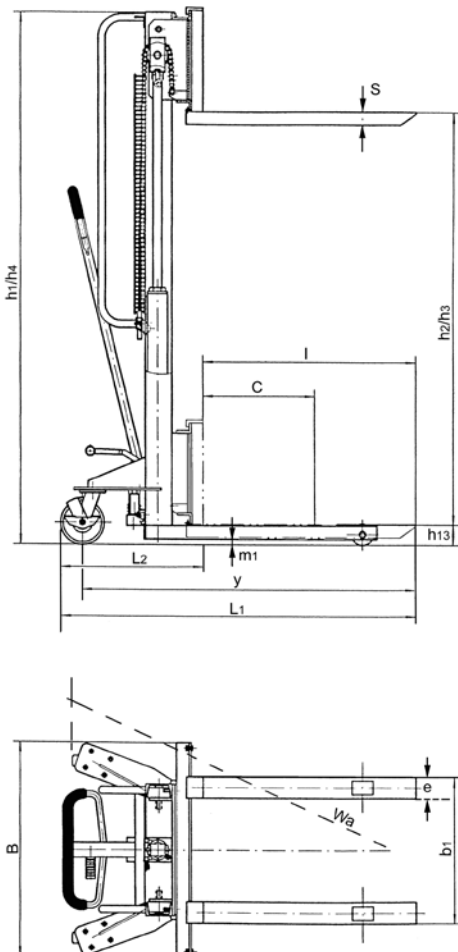

### Technical data model HV 0516

Model	HV 0516
Art.-No.	040005551
Capacity, kg	500
Load center c, mm	600
Wheelbase y, mm	1630
Weight, kg	217
Tyre type*	PUR/PA
Steering rollers, mm	150x40
Load rollers, mm	80x35
Number of wheels/load rollers	2/2
Height, mast retracted h1, mm	2000
Free lift h2, mm	1520
Stroke h3, mm	1520
Height, mast extended h4, mm	2000
Lifting height max. h3 + h13, mm	1600
Fork height lowered h13, mm	80
Overall length L1, mm	1690
Length incl. apron L2, mm	550
Overall width B, mm	800
Fork height s, mm	45
Fork width e, mm	100
Fork length l, mm	1150
Outside dimension of forks adjustable from up to b1, mm	200/770
Ground clearance m1, mm	25
Turning circle radius Wa, mm	1500
Lift per one crank rotation with/without load, mm	32

\*PA... Polyamide



### Manual drive stacker model HV 1008

### Manual drive stacker model HV 1016

Capacity 1000 kg

Ideal for the occasional, internal application of stacking and transporting of palletised goods.

#### Features

- Ergonomic safety control handle for one-hand operation of lifting, driving and lowering.
- Easy handling due to forced steering rollers.
- Lowering speed can be finely metered for sensitive lowering of the load.
- Single-acting hand pump with increased lift per handle stroke.
- Quick-lift for loads up to 100 kg.
- Robust mast construction with hard chromium plated piston.
- Steering roller with brake for safe parking of the hand stacker.



Technical data model HV 1008 and model HV 1016

Model	HV 1008	HV 1016
Art.-No.	034518032	034518030
Capacity, kg	1000	1000
Load center c, mm	600	600
Wheelbase y, mm	1075	1075
Weight, kg	179	205
Tyre type*	PUR/PUR	PUR/PUR
Steering rollers, mm	180x50	180x50
Load rollers, mm	80x55	80x55
Number of wheels/load rollers	2/2	2/2
Height, mast retracted h1, mm	1300	1965
Free lift h2, mm	810	1510
Stroke h3, mm	810	1510
Height, mast extended h4, mm	1300	1965
Lifting height max. h3 + h13, mm	900	1600
Fork height lowered h13, mm	90	90
Overall length L1, mm	1675	1675
Length incl. apron L2, mm	552	552
Overall width B, mm	765	765
Fork height s, mm	60	60
Fork width e, mm	60	60
Fork length l, mm	1122	1122
Outside dimension of forks b1, mm	570	570
Ground clearance m1, mm	25	25
Aisle width pallet Ast, mm	1875	1875
Turning circle radius Wa, mm	1445	1445
Lift per one crank rotation with/without load, mm	17/50	17/50

\*PUR... Polyurethane

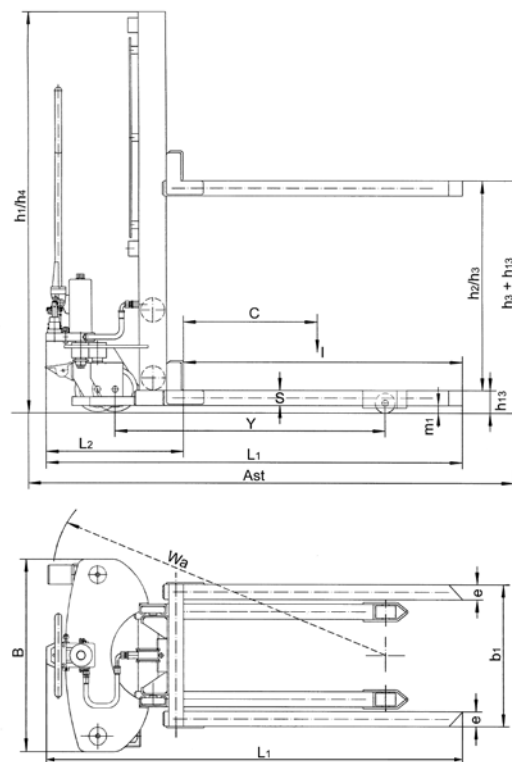

### Manual drive stacker with electric-hydraulic lift, model EHH PS

Capacity 1000 - 1500 kg,  
fork height max. 3500 mm

Suitable for occasional to medium applications of stacking  
and transporting palletised loads, also in confined areas.

#### Features

- Easy to operate via tie-rod guides to both steer wheels.
- Compact electric-hydraulic lifting device and overload protection.
- Finely metered lowering of load through pressure relief valve and adjustable lowering valve.
- Mast welded from precision profiles, fork carriage with maintenance free guide rollers.
- Parking brake.
- Robust frame with two load and two steer rollers.

#### Scope of delivery

- Battery and battery charger included.



## Technical data model EHH PS

Model	EHH PS 1009	EHH PS 1016	EHH PS 1020	EHH PS 1225	EHH PS 1229	EHH PS 1235
Art.-No.	040046051	040044422	040044423	040044424	040044425	040044426
Capacity (up to 2.5 m Hub), kg	1000	1000	1000	1200	1200	1200
Load center c, mm	600	600	600	600	600	600
Wheelbase y, mm	965	965	965	1155	1155	1155
Weight (with battery), kg	296	311	321	433	449	496
Tyre type*	VG/PA	VG/PA	VG/PA	PUR/PA	PUR/PA	PUR/PA
Steering rollers, mm	200x50	200x50	200x50	200x50	200x50	200x50
Load rollers, mm	82x70	82x70	82x70	82x70	82x70	82x70
Number of wheels/load rollers	2/2	2/3	2/4	2/5	2/6	2/7
Height, mast retracted h1, mm	1300	1970	2370	1780	1980	2250
Free lift h2, mm	810	1510	1910	-	-	80
Stroke h3, mm	810	1510	1910	2410	2810	3410
Height, mast extended h4, mm	1300	1970	2370	2985	3385	3915
Lifting height max. h3 + h13, mm	900	1600	2000	2500	2900	3500
Fork height lowered h13, mm	90	90	90	90	90	90
Overall length L1, mm	1750	1750	1750	1850	1850	1850
Length incl. apron L2, mm	600	600	600	700	700	700
Overall width b1/b2, mm	750	750	750	850	850	850
Fork height s, mm	70	70	70	70	70	70
Fork width e, mm	150	150	150	150	150	150
Fork length l, mm	1150	1150	1150	1150	1150	1150
Outside dimension of forks b5, mm	560	560	560	560	560	560
Ground clearance m2, mm	20	20	20	20	20	20
Aisle width pallet Ast, mm	2210	2210	2210	2375	2375	2375
Turning circle radius Wa, mm	1440	1440	1440	1760	1760	1760
Lifting speed with/without load, m/s	0.09/0.12	0.09/0.12	0.09/0.12	0.08/0.12	0.08/0.12	0.08/0.12
Lowering speed with/without load, m/s	0.4/0.1	0.4/0.1	0.4/0.1	0.4/0.1	0.4/0.1	0.4/0.1
Hoist motor rating, kW	1.6	1.6	1.6	2.2	2.2	2.2
Battery according to DIN 43531	starter	starter	starter	starter	starter	starter
Battery charger, V/A	12-15	12-15	12-15	24-13	24-13	24-13
Battery voltage capacity, V/Ah	12/74	12/74	12/74	24/74	24/74	24/74

\*PA... Polyamide, PUR... Polyurethane, VG... Solid rubber

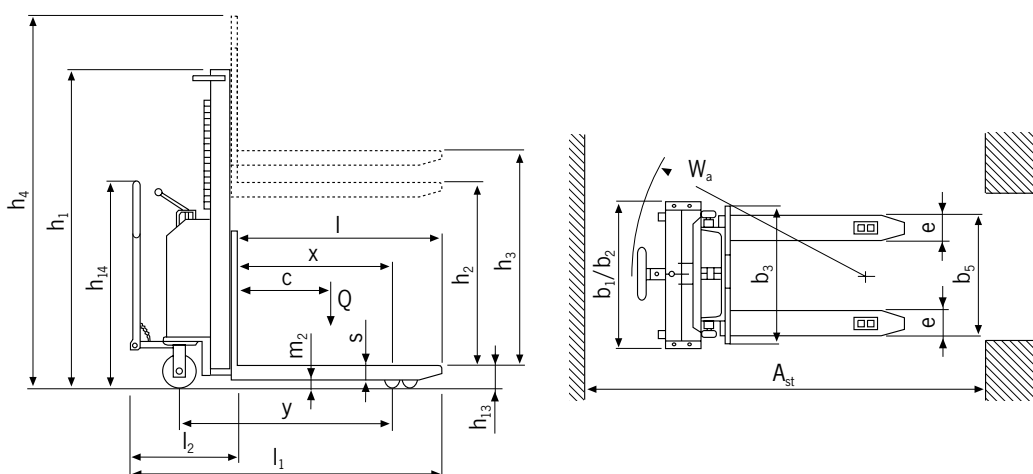

## Electric pedestrian stacker model EGV PSL

Capacity 1000 - 1200 kg,  
fork height max. 3500 mm

Ideal for stacking and transportation of palletised goods within a warehouse environment for short haul and medium work load applications.

### Features

- Multifunctional control handle for easy handling. The electric pallet lift truck will automatically be slowed down if the control handle is no longer in the users hand.
- Reliable impulse control for stepless regulation of drive speed.
- Compact electric-hydraulic lifting device and overload protection.
- Finely metered lowering of load through pressure relief valve and adjustable lowering valve.
- Mast welded from precision profiles, fork carriage with maintenance free guide rollers.
- Solid frame with one drive wheel and two load and two guide rollers.

### Scope of delivery

- Battery and battery charger included.





## Technical data model EGV PSL

Model	EGV PSL 1016	EGV PSL 1020	EGV PSL 1225	EGV PSL 1229	EGV PSL 1235
Art.-No.	40040502	040044420	40040503	40040504	040044421
Actuation	electric	electric	electric	electric	electric
Operation	pedestrian	pedestrian	pedestrian	pedestrian	pedestrian
Capacity (up to 2.5 m lift), kg	1000	1000	1200	1200	1200
Load center c, mm	600	600	600	600	600
Wheelbase y, mm	1190	1190	1190	1190	1190
Weight (with battery), kg	393	413	481	496	531
Tyre type*	PUR+VG/PUR	PUR+VG/PUR	PUR+VG/PUR	PUR+VG/PUR	PUR+VG/PUR
Steering rollers, mm	240x60+150x40	240x60+150x40	250x76+150x40	250x76+150x40	250x76+150x40
Load rollers, mm	82x70	82x70	82x70	82x70	82x70
Number of wheels/load rollers (x=driven)	2+1x/2	2+1x/2	2+1x/2	2+1x/2	2+1x/2
Height, mast retracted h1, mm	1970	2370	1780	1980	2250
Free lift h2, mm	1510	1910	-	-	80
Stroke, mm	1510	1910	2410	2810	3410
Height, mast extended h4, mm	1970	2370	2985	3385	3915
Fork height max. h3, mm	1600	2000	2500	2900	3500
Height of control handle max., mm	1390	1390	1390	1390	1390
Fork height lowered, mm	90	90	90	90	90
Overall length l+L2, mm	1825	1825	1825	1825	1825
Length incl. apron L2, mm	675	675	675	675	675
Overall width b1/b2, mm	850	850	850	850	850
Fork height s, mm	70	70	70	70	70
Fork width e, mm	150	150	150	150	150
Fork length l, mm	1150	1150	1150	1150	1150
Clearance fork tip-roller, x	365	365	365	365	365
Outside dimension of forks b5, mm	560	560	560	560	560
Ground clearance m2, mm	20	20	20	20	20
Aisle width pallet Ast, mm	2075	2075	2075	2075	2075
Turning circle radius Wa, mm	1460	1460	1460	1460	1460
Travel speed with/without load, km/h	4.0/5.0	4.0/5.0	4.0/5.0	4.0/5.0	4.0/5.0
Lifting speed with/without load, m/s	0.09/0.12	0.09/0.12	0.08/0.12	0.08/0.12	0.08/0.12
Lowering speed with/without load, m/s	0.4/0.1	0.4/0.1	0.4/0.1	0.4/0.1	0.4/0.1
Gradient with/without load, %	5/10	5/10	5/10	5/10	5/10
Service brake	electric	electric	electric	electric	electric
Drive motor rating, kW	0.5	0.5	0.7	0.7	0.7
Hoist motor rating, kW	2.2	2.2	2.2	2.2	2.2
Battery	starter	starter	starter	starter	starter
Battery charger, V/A	24/13	24/13	24/20	24/20	24/20
Battery voltage, V/Ah	24/74	24/74	24/92	24/92	24/92
Type of control	impulse	impulse	impulse	impulse	impulse

\*PUR... Polyurethane, VG... Solid rubber

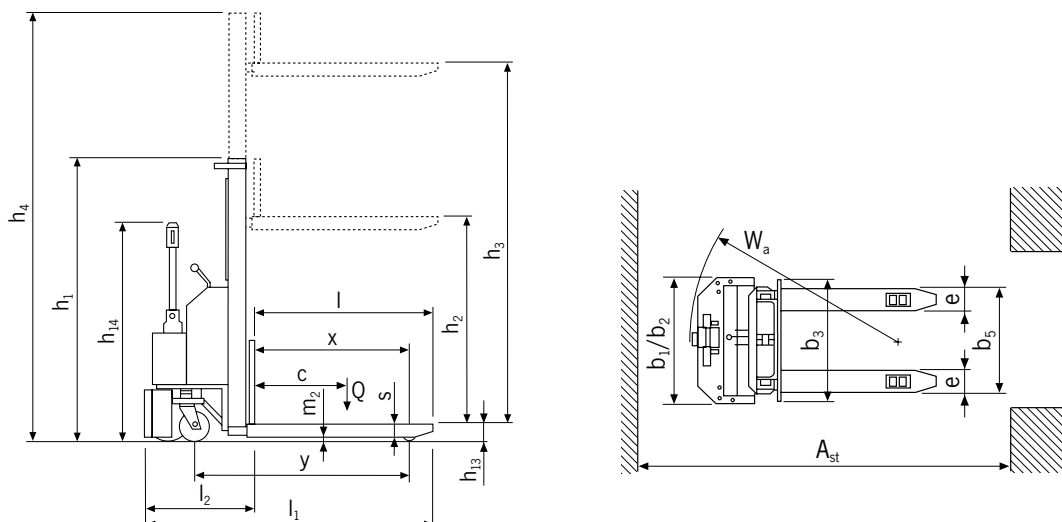

## Electric pedestrian stacker model EGV PSH

Capacity 1200 - 1600 kg,  
fork height max. 5000 mm

Ideal for stacking and transportation of palletised loads within a warehouse environment for long haul and high work load applications.

### Features

- Multifunctional control handle for easy handling. The electric pallet lift truck will automatically be slowed down if the control handle is no longer in the users hand.
- Reliable impulse control for stepless regulation of drive speed.
- Compact electric-hydraulic lifting device and overload protection.
- Finely metered lowering of load through pressure relief valve and adjustable lowering valve.
- Mast welded from precision profiles, fork carriage with maintenance free guide rollers.
- Solid frame with one drive wheel and two load and two guide rollers.
- Battery size depends on the type of application.

### Options

- Drivers platform



## Technical data model EGV PSH

Model	EGV PSH 1216	EGV PSH 1225	EGV PSH 1229	EGV PSH 1235	EGV PSH 1445
Art.-No.	040046052	040046053	040046054	040046055	040046056
Actuation	electric	electric	electric	electric	electric
Operation	pedestrian	pedestrian	pedestrian	pedestrian	pedestrian
Capacity (up to 2.5 m lift), kg	1200	1200	1200	1200	1400
Load center c, mm	600	600	600	600	600
Wheelbase y, mm	1363	1363	1363	1363	1429
Weight (with battery 180 Ah), kg	650	725	780	790	1010
Tyre type*	PUR+VG/PUR	PUR+VG/PUR	PUR+VG/PUR	PUR+VG/PUR	PUR+VG/PUR
Steering rollers, mm	250x76+125x50	250x76+125x50	250x76+125x50	250x76+125x50	250x101+125x50
Load rollers, mm	82x70	82x70	82x70	82x70	82x70
Number of wheels/load rollers (x=driven)	2+1x/2	2+1x/2	2+1x/2	2+1x/2	2+1x/4
Height, mast retracted h1, mm	1965	1765	1965	2265	2099
Free lift h2, mm	1510	-	-	-	-
Stroke, mm	1510	2410	2810	3410	4410
Height, mast extended h4, mm	1965	2970	3370	3970	5039
Fork height max. h3, mm	1600	2500	2900	3500	4500
Height of control handle max., mm	1385	1385	1385	1385	1385
Fork height lowered, mm	90	90	90	90	90
Overall length L1, mm	1964	1964	1964	1964	2001
Length incl. apron L2, mm	809	809	809	809	851
Overall width b1/b2, mm	850	850	850	850	850
Fork height s, mm	70	70	70	70	70
Fork width e, mm	170	170	170	170	170
Fork length l, mm	1150	1150	1150	1150	1150
Outside dimension of forks b5, mm	560	560	560	560	560
Ground clearance, mm	20	20	20	20	20
Aisle width pallet Ast, mm	2228	2228	2228	2228	2252
Turning circle radius Wa, mm	1586	1586	1586	1586	1649
Travel speed with/without load, km/h	5.5/6	5.5/6	5.5/6	5.5/6	5.5/6
Lifting speed with/without load, m/s	0.09/0.15	0.09/0.15	0.09/0.15	0.09/0.15	0.13/0.17
Lowering speed with/without load, m/s	0.4/0.1	0.4/0.1	0.4/0.1	0.4/0.1	0.4/0.1
Gradient max. with/without load, %	5/10	5/10	5/10	5/10	5/10
Service brake	electric	electric	electric	electric	electric
Drive motor rating, kW	1.2	1.2	1.2	1.2	1.2
Hoist motor rating, kW	2.5	2.5	2.5	2.5	3.0
Battery**	PzS	PzS	PzS	PzS	PzS
Battery voltage, V/Ah	24/180-210-315	24/180-210-315	24/180-210-315	24/180-210-315	24/180-210-315
Battery weight, kg	200-285	200-285	200-285	200-285	200-285
Type of control	impulse	impulse	impulse	impulse	impulse

\*PUR... Polyurethane, VG... Solid rubber

\*\*PzS... Traction battery

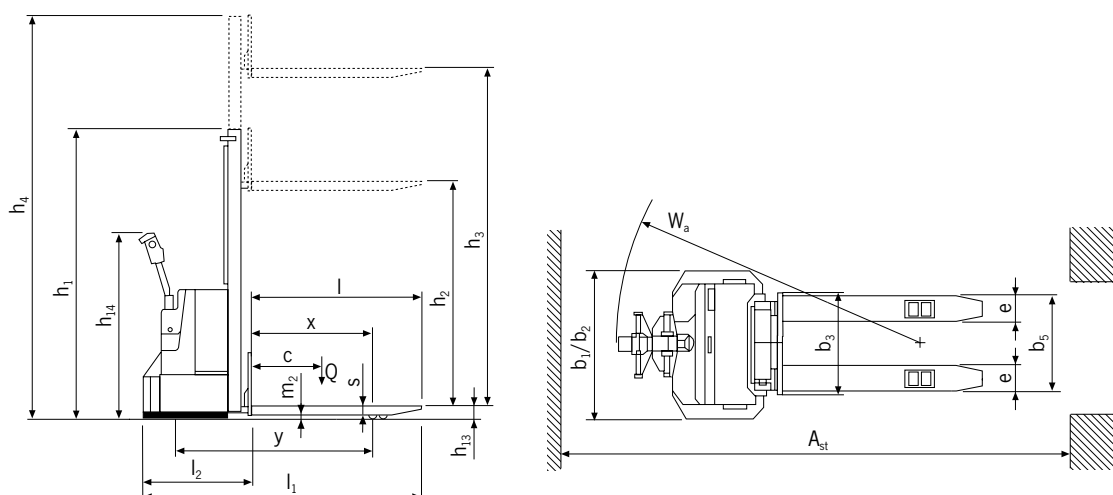

## Technical data model EGV PSH

Model	EGV PSH 1445 FL	EGV PSH 1450	EGV PSH 1616	EGV PSH 1625	EGV PSH 1629	EGV PSH 1635
Art.-No.	040046057	040046058	040046059	040046060	040040501	040046061
Actuation	electric	electric	electric	electric	electric	electric
Operation	pedestrian	pedestrian	pedestrian	pedestrian	pedestrian	pedestrian
Capacity (up to 2.5 m lift), kg	1400	1400	1600	1600	1600	1600
Load center c, mm	600	600	600	600	600	600
Wheelbase y, mm	1429	1429	1429	1429	1429	1429
Weight (with battery 180 Ah), kg	1069	1088	754	849	874	914
Tyre type*	PUR+VG/PUR	PUR+VG/PUR	PUR+VG/PUR	PUR+VG/PUR	PUR+VG/PUR	PUR+VG/PUR
Steering rollers, mm	250x101+125x50	250x101+125x50	250x101+125x50	250x101+125x50	250x101+125x50	250x101+125x50
Load rollers, mm	82x70	82x70	82x70	82x70	82x70	82x70
Number of wheels/load rollers (x=driven)	2+1x/4	2+1x/4	2+1x/4	2+1x/4	2+1x/4	2+1x/4
Height, mast retracted h1, mm	2132	2266	1965	1765	1965	2265
Free lift h2, mm	1510	-	1510	-	-	-
Lift, mm	4410	4910	1510	2410	2810	3410
Height, mast extended h4, mm	5072	5540	1965	2970	3370	3970
Fork height max. h3, mm	4500	5000	1600	2500	2.900	3500
Height of control handle max., mm	1385	1385	1385	1385	1385	1385
Fork height lowered, mm	90	90	90	90	90	90
Overall length L1, mm	2001	2001	1991	1991	1991	1991
Length incl. apron L2, mm	851	851	841	841	841	841
Overall width b1/b2, mm	850	850	850	850	850	850
Fork height s, mm	70	70	70	70	70	70
Fork width e, mm	170	170	170	170	170	170
Fork length l, mm	1150	1150	1150	1150	1150	1150
Outside dimension of forks b5, mm	560	560	560	560	560	560
Ground clearance, mm	20	20	20	20	20	20
Aisle width pallet Ast, mm	2252	2252	2241	2241	2241	2241
Turning circle radius Wa, mm	1649	1649	1649	1649	1649	1649
Travel speed with/without load, km/h	5.5/6	5.5/6	5.5/6	5.5/6	5.5/6	5.5/6
Lifting speed with/without load, m/s	0.12/0.17	0.13/0.17	0.08/0.12	0.08/0.12	0.08/0.12	0.08/0.12
Lowering speed with/without load, m/s	0.4/0.1	0.4/0.1	0.4/0.1	0.4/0.1	0.4/0.1	0.4/0.1
Gradient max. with/without load, %	5/10	5/10	5/10	5/10	5/10	5/10
Service brake	electric	electric	electric	electric	electric	electric
Drive motor rating, kW	1.2	1.2	1.2	1.2	1.2	1.2
Hoist motor rating, kW	3.0	3.0	2.5	2.5	2.5	2.5
Battery**	PzS	PzS	PzS	PzS	PzS	PzS
Battery voltage, V/Ah	24/180-210-315	24/180-210-315	24/180-210-315	24/180-210-315	24/180-210-315	24/180-210-315
Battery weight, kg	200-285	200-285	200-285	200-285	200-285	200-285
Type of control	impulse	impulse	impulse	impulse	impulse	impulse

\*PUR... Polyurethane, VG... Solid rubber

\*\*PzS... Traction battery

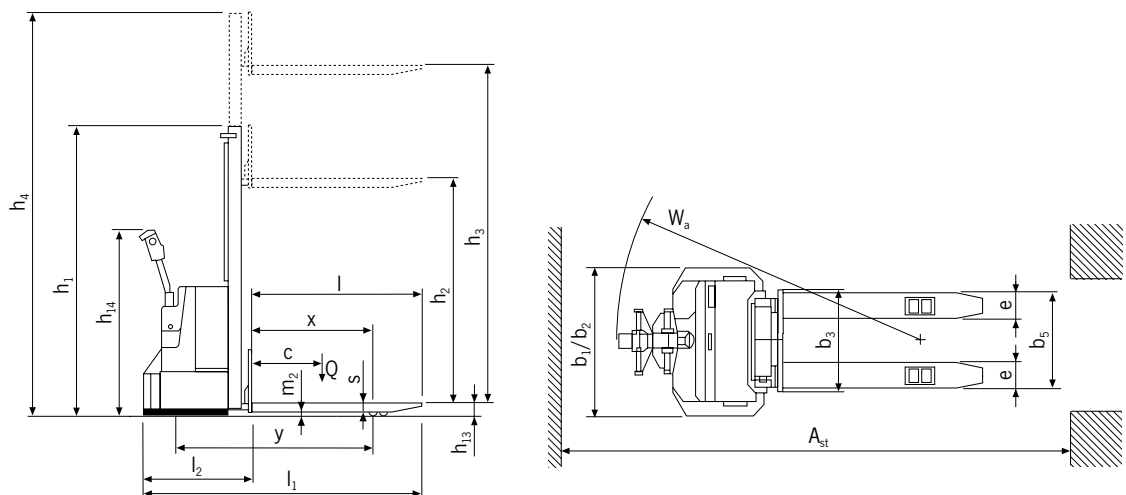

## Platformlift model PRAKTIKUS HP

Capacity 200 - 400 kg,  
platform height max. 1200 mm

For the occasional, internal application of lifting and transporting of goods.

### Features

- Easy lifting by tiltable foot pedal.
- Lowering speed can be finely metered for sensitive lowering of the load.
- Ergonomic handlebar for easy operation.
- Steering roller with parking brake for safe parking of the hand stacker.
- Robust construction with chrome plated chassis, hard chromium plated piston and pressure relief valve.
- Covered chain deflection for increased safety.



### Technical data model PRAKTIKUS HP

Model	HP 0285	HP 0212	HP 0485	HP 0412
Art.-No.	040008776	040008777	040008778	040008779
Capacity, kg	200	200	400	400
Platform height max. $h_3 + h_{13}$ , mm	850	1200	850	1200
Platform height min. $h_{13}$ , mm	200	200	200	200
Free lift $h_2$ , mm	650	1000	650	1000
Stroke $h_3$ , mm	650	1000	650	1000
Lifting height per pump stroke, mm	23	23	23	23
Overall height $h_1$ , mm	960	1310	960	1310
Overall length $L_1$ , mm	1037	1037	1037	1037
Overall width $b_1$ , mm	590	590	590	590
Platform length $P_1$ , mm	650	650	650	650
Platform width $P_2$ , mm	550	550	550	550
Tyre type*	VG/VG	VG/VG	VG/VG	VG/VG
Steering rollers, mm	150x45	150x45	150x45	150x45
Load rollers, mm	150x45	150x45	150x45	150x45
Number of wheels/load rollers	2/2	2/2	2/2	2/2
Ground clearance $m_1$ , mm	50	50	50	50
Wheelbase $y$ , mm	785	785	785	785
Weight, kg	65	70	66	71

\*VG... Solid rubber

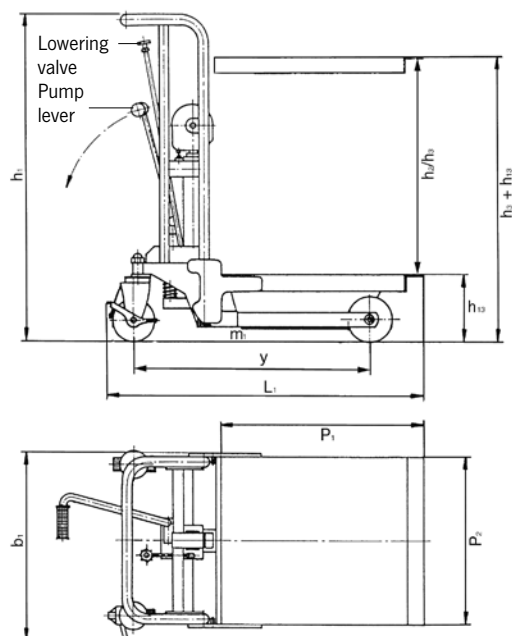



## Scissor elevating platform, mobile with single scissor model HX

Capacity 150 - 750 kg,  
platform height max. 1000 mm

For the independent lifting and supplying of loads within a warehouse environment.

### Features

- Hydraulic lifting of the load with foot pedal.
- Lowering speed can be finely metered for sensitive lowering of the load.
- Ergonomic handlebar for easy operation, tiltable for model HX 150.
- Steering roller with parking brake for safe parking of the hand stacker.
- Robust construction with hard chromium plated piston and pressure relief valve.

### Technical data model HX

Model	HX 150	HX 300	HX 500	HX 750
Art.-No.	034600020	034600021	034600022	034600023
Capacity, kg	150	300	500	750
Platform height max. $h_3 + h_{13}$ , mm	720	880	880	1000
Platform height min. $h_{13}$ , mm	220	285	285	420
Stroke $h_3$ , mm	500	595	595	580
Lifting height per pump stroke, mm	27	31	31	15
Overall height $h_1$ , mm	960	984	984	990
Overall length $L_1$ , mm	908	1093	1093	1330
Overall width $b_1$ , mm	450	500	500	600
Platform length $P_1$ , mm	700	850	850	1000
Platform width $P_2$ , mm	450	500	500	510
Tyre type*	PUR/PUR	PUR/PUR	PUR/PUR	PUR/PUR
Rollers, mm	100x36	128x40	128x40	147x50
Number of wheels/load rollers	2/2	2/2	2/2	2/2
Weight, kg	49	78	82	120

\*PUR... Polyurethane

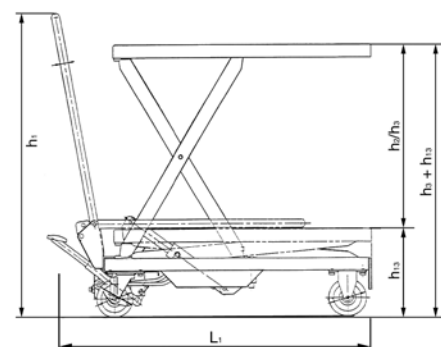
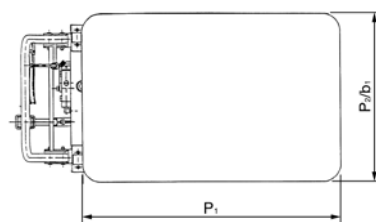

## Scissor elevating platform, mobile with double scissor model HX-D

Capacity 350 - 700 kg,  
platform height max. 1500 mm

For the independant lifting and supplying of light up to medium loads within a warehouse environment.

### Features

- Hydraulic lifting of the load with foot pedal.
- Lowering speed can be finely metered for sensitive lowering of the load.
- Ergonomic handlebar for easy operation.
- Steering roller with parking brake for safe parking of the hand stacker.
- Robust construction with hard chromium plated piston and pressure relief valve.
- According to EN 1570, prEN 1757-4.



### Technical data model HX-D

Model	HX-D 0350	HX-D 700
Art.-No.	034600024	040047506
Capacity, kg	350	700
Platform height max. $h_3 + h_{13}$ , mm	1300	1500
Platform height min. $h_{13}$ , mm	370	445
Stroke $h_3$ , mm	930	1055
Lifting height per pump stroke, mm	21	11
Overall height $h_1$ , mm	965	1015
Overall length $L_1$ , mm	1140	1480
Overall width $b_1$ , mm	500	610
Platform length $P_1$ , mm	910	1220
Platform width $P_2$ , mm	500	610
Tyre type*	PUR/PUR	PUR/PUR
Load rollers, mm	128 x 40	128 x 40
Number of wheels/load rollers	2/2	2/2
Weight, kg	136	195

\*PA... Polyamide, PUR... Polyurethane, VG... Solid rubber

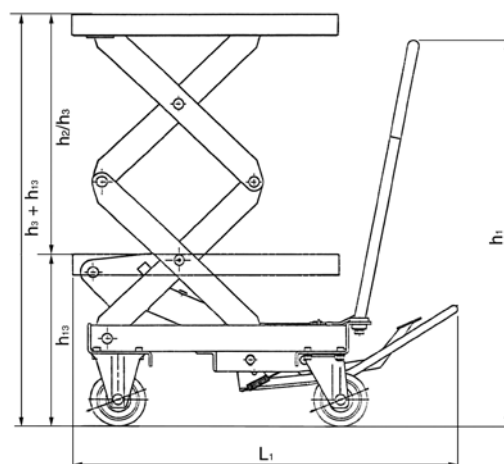
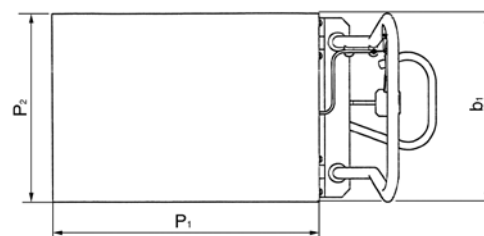





**Scissor elevating platform,  
mobile with single scissor and  
- manual hydraulic  
model HF...SM**

Capacity 150 - 1250 kg,  
platform height max. 1050 mm

**- electric hydraulic system  
model HF...SE**

Capacity 300 - 1250 kg,  
platform height max. 1050 mm

For lifting and supplying goods independent of the  
location.

**Features**

- Manual hydraulic system with pedal or electric hydraulic system with dead man function – a main current connection is not required.
- High safety due to pressure relief and lowering valve.
- Robust single scissor construction, above 300 kg with solid steer scissor.
- Pivoting platform with mechanic adjustment for safe maintenance work.
- Compact design with low OAH.
- Steering and fixed rollers with service-free roller bearings. One steer roller can be locked in position for parking.
- According to EN 1570 and machinery directive 2006/42/EG.



**Scope of delivery**

- Models with electric-hydraulic pump are supplied complete with battery and charger.

## Technical data model HF/SM

Model	HF 015-078 SM	HF 030-084 SM	HF 050-090 SM	HF 080-105 SM	HF 100-105 SM	HF 125-105 SM
Art.-No.	24501078	24503084	24505090	24508105	24510105	24512105
Capacity, kg	150	300	500	800	1000	1250
Platform height max. h <sub>2</sub> , mm	780	840	900	1050	1050	1050
Platform height min. h <sub>1</sub> , mm	255	335	340	360	360	360
Stroke h <sub>3</sub> , mm	525	505	560	690	690	690
Overall length l <sub>1</sub> , mm	990	1050	1320	1650	2350	1650
Overall width b <sub>1</sub> , mm	450	500	610	860	1000	860
Platform length l, mm	760	840	1.030	1350	2000	1350
Platform width b <sub>1</sub> , mm	450	500	610	840	1000	840
Tyre type**	VG	PUR	PUR	PA	PA	PA
Service brake	manual	manual	manual	manual	manual	manual
Number of strokes for max. lift	14	18	29	40	80	80
Weight (with battery and battery charger), kg	41	83	109	222	350	230

\*\*PA... Polyamide, PUR... Polyurethane, VG... Solid rubber

## Technical data model HF/SE

Model	HF 030-084 SE	HF 050-090 SE	HF 080-105 SE	HF 100-105 SE	HF 125-105 SE
Art.-No.	24603084	24605090	24608105	24610105	24612105
Capacity, kg	300	500	800	1000	1250
Platform height max. h <sub>2</sub> , mm	840	900	1050	1050	1050
Platform height min. h <sub>1</sub> , mm	335	340	360	360	360
Stroke h <sub>3</sub> , mm	505	560	690	690	690
Overall length l <sub>1</sub> , mm	1130	1330	1650	2350	1650
Overall width b <sub>1</sub> , mm	500	610	860	1000	860
Platform length l, mm	840	1030	1350	2000	1350
Platform width b <sub>1</sub> , mm	500	610	840	1000	840
Tyre type**	PUR	PUR	PA	PA	PA
Service brake	manual	manual	manual	manual	manual
Number of strokes for max. lift	electric	electric	electric	electric	electric
Weight (with battery and battery charger), kg	120	158	270	397	278

\*\* PA... Polyamide, PUR... Polyurethane

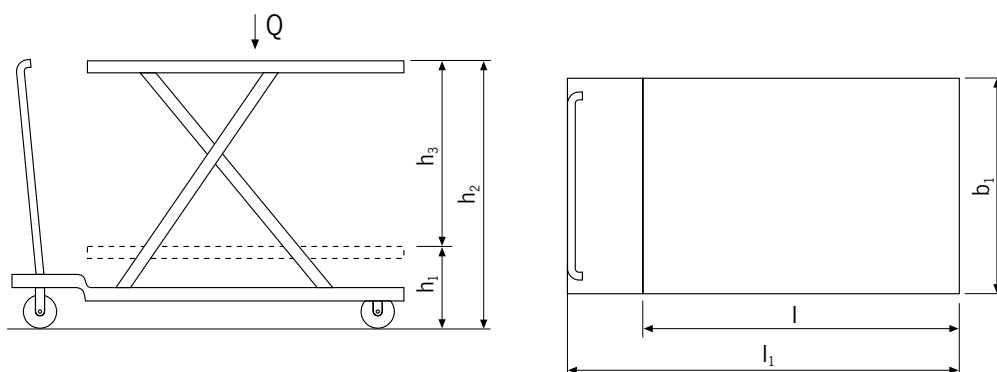



**Scissor elevating platform,  
mobile with double vertical  
scissor and**

**- manual hydraulic**

**model HF...DM**

**- electric hydraulic system**

**model HF...DE**

**Capacity 125 - 800 kg,  
platform height max. 1900 mm**

For lifting and supplying goods independent of the location.

#### **Features**

- Manual hydraulic system with pedal or electric hydraulic system with dead man function – a main current connection is not required.
- High safety due to pressure relief and lowering valve.
- Robust single scissor construction, above 300 kg with solid steer scissor.
- Pivoting platform with mechanic adjustment for safe maintenance work.
- Compact design with low OAH.
- Steering and fixed rollers with service-free roller bearings. One steer roller can be locked in position for parking.
- According to EN 1570 and machinery directive 2006/42/EG.



#### **Scope of delivery**

- Models with electric-hydraulic pump are supplied complete with battery and charger.

## Technical data model HF/DM

Model	HF 012-142 DM	HF 045-155 DM	HF 050-190 DM	HF 080-190 DM
Art.-No.	24701142	24704155	24705190	24708190
Capacity, kg	125	450	500	800
Platform height max. h <sub>2</sub> , mm	1420	1550	1900	1900
Platform height min. h <sub>1</sub> , mm	430	295	490	490
Stroke h <sub>3</sub> , mm	990	1255	1410	1410
Overall length l <sub>1</sub> , mm	1090	1350	1650	1650
Overall width b <sub>1</sub> , mm	500	665	860	860
Platform length l, mm	840	1030	1350	1350
Platform width b <sub>1</sub> , mm	500	610	840	840
Tyre type**	PUR	PUR	PA	PA
Service brake	manual	manual	manual	manual
Number of strokes for max. lift	19	71	80	160
Weight (with battery and battery charger), kg	100	143	306	315

\*\*PA... Polyamide, PUR... Polyurethane

## Technical data model HF/DE

Model	HF 012-142 DE	HF 045-155 DE	HF 050-190 DE	HF 080-190 DE
Art.-No.	24801142	24804155	24805190	24808190
Capacity, kg	125	450	500	800
Platform height max. h <sub>2</sub> , mm	1420	1550	1900	1900
Platform height min. h <sub>1</sub> , mm	430	295	490	490
Stroke h <sub>3</sub> , mm	990	1255	1410	1410
Overall length l <sub>1</sub> , mm	1090	1350	1650	1650
Overall width b <sub>1</sub> , mm	500	665	860	860
Platform length l, mm	840	1030	1350	1350
Platform width b <sub>1</sub> , mm	500	610	840	840
Tyre type**	PUR	PUR	PA	PA
Service brake	manual	manual	manual	manual
Number of strokes for max. lift	electric	electric	electric	electric
Weight (with battery and battery charger), kg	147	190	352	363

\*\*PA... Polyamide, PUR... Polyurethane

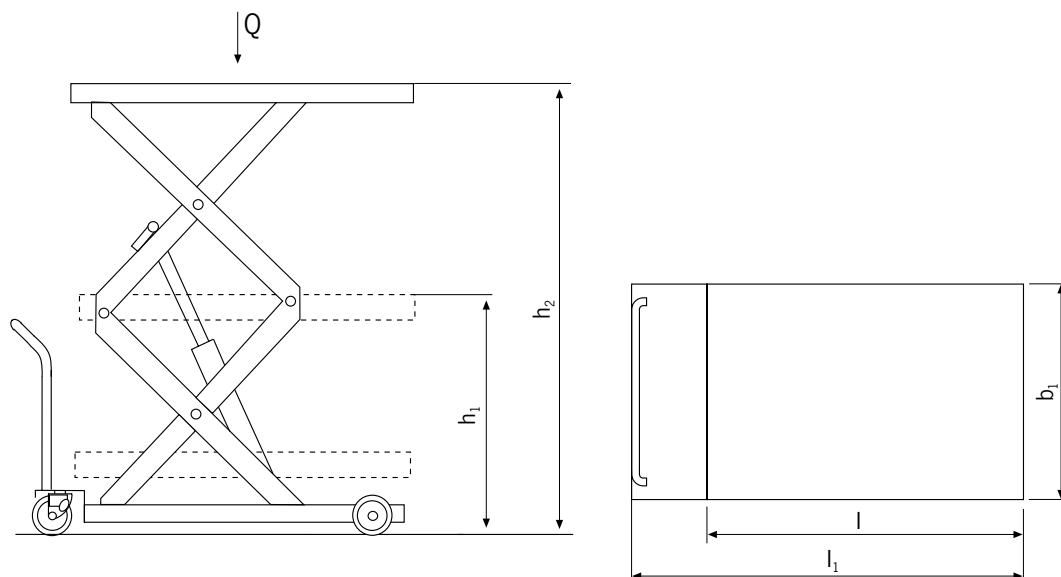



## Mobile elevating work bench model HW

Capacity 1000 kg,  
platform height max. 1320 mm

For lifting and transporting of heavy loads in manufacturing and assembly processes.

### Features

- Hydraulic lifting and lowering of the load with foot pedal.
- Lowering speed can be finely adjusted for sensitive lowering of the load.
- Ergonomic handlebar for easy operation.
- Steering roller with locking device for safe parking of the hand stacker.
- Robust construction with hard chromium plated piston and pressure relief valve.

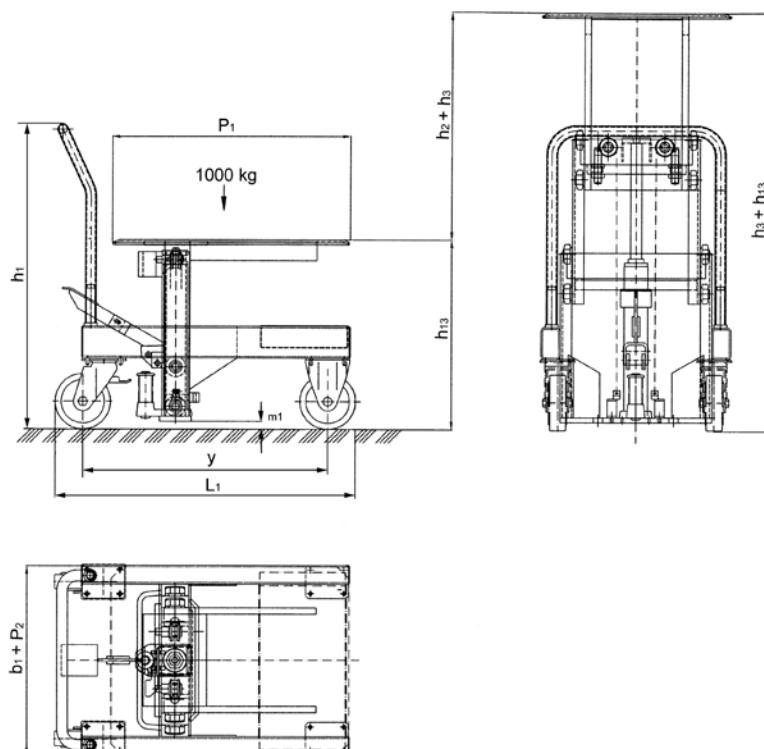

### Technical data model HW 10

Model	HW 10
Art.-No.	040007617
Capacity, kg	1000
Platform height max. $h_3 + h_{13}$ , mm	1320
Platform height min. $h_{13}$ , mm	600
Overall height $h_1$ , mm	950
Free lift $h_2$ , mm	720
Stroke $h_3$ , mm	720
Overall length $L_1$ , mm	947
Platform length $P_1$ , mm	750
Platform width $P_2$ , mm	600
Overall width $b_1$ , mm	600
Tyre type*	PA/PA
Steering rollers, mm	175x50
Load rollers, mm	175x50
Number of wheels/load rollers	2/2
Wheelbase $y$ , mm	772
Weight, kg	160
Ground clearance $m_1$ , mm	25
Lifting height per pump stroke, mm	9

\*PA... Polyamide





## Steerman® Heavy load moving systems model SX and model S

Capacity 10 - 100 t

These universal heavy load moving systems have been designed for the safe and cost saving transport of loads up to 100 tons. Individual configuration of steering and rear skates also allows higher capacities. Transport of heavy loads (e.g. machines, construction parts, steel structures) is normally made with a stable three point loading system.

Transport of extremely bulky or heavy loads with an unfavourable center of balance, may also be executed with a four point loading system. The robust towing bar in connection with the unique turntable on large diameter thrust bearings allows effortless steering of the load. The rear skates are aligned parallel by means of a tie rod and kept in position, thus ensuring time saving and smooth transportation of the load.

The skates are powder coated and all connecting elements corrosion-resistant. Highest safety requirements have been considered.

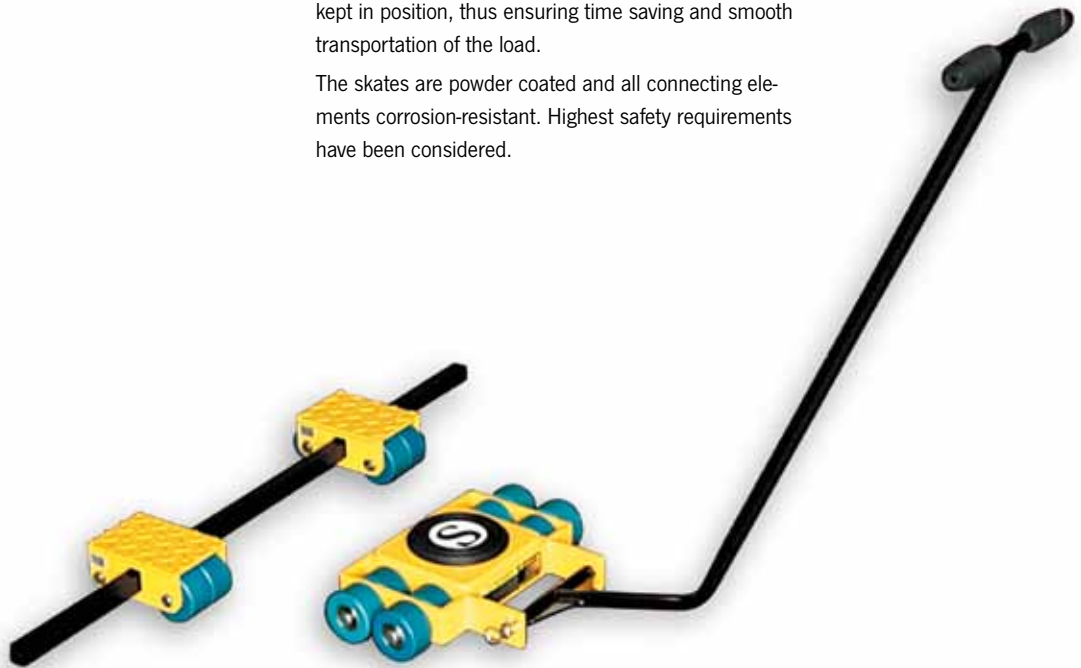

Rollers with ball bearing



Chassis from ductile graphite iron



Ball bearing for turning plate





## Features

- The modular design ensures an extremely simple operation and simultaneously offers a wider range of combinations.
- The construction of the load moving systems is extremely robust and resistant to distortion.
- The skates are smooth-running and provide an incredibly low rolling resistance even with the heaviest loads.
- Twin rollers (instead of one wide roller) ensure low rolling resistance even at a narrow curve radius.
- The universal joint suspension of the roller groups contributes to a positive contact when travelling over uneven floors.
- The roller wheels are manufactured with abrasion-resistant, elastic polyamide. They are protected against breakage and have high chemical resistance.
- Each individual roller is made from high tensile material which ensures extremely quiet running.
- The rollers are suitable for all in-plant floors and will not damage normal floor covering.
- The load moving systems can be easily dismantled and facilitate transport even in small trucks.
- The load moving systems have been developed for professional applications and are practically maintenance-free.
- All rollers are provided with two encapsulated, lifetime lubricated ball bearings.
- The front steering skate is equipped with an amply dimensioned axial ball bearing underneath the turntable.
- From SX-10 the front and rear skates are available individually.



Model S-60

## Technical data model SX and model S

Model	EAN-No. 4025092*	Capacity t	Overall height mm	Number of rollers	Roller diameter mm	Colour of rollers	Weight kg
SX-10	*158503	10	102	16	82	black	54
SX-15	*158527	15	102	32	82	blue	76
SX-20	*158541	20	102	32	82	black	76
SX-25	*158565	25	110	48	82	blue	136
SX-30	*158589	30	110	48	82	black	136
S-40	*161923	40	170	48	115	blue	302
S-60	*161930	60	170	48	115	black	302
S-80	*158640	80	210	48	150	blue	525
S-100	*158664	100	210	48	150	black	525



Model LF-1

## Load moving skates and systems with fixed wheels model LF

### Capacity 1 - 6 t

The components of the load moving skates can be universally combined and are ideal for the transport of medium heavy loads of all kinds.

The components can be used individually or adapted to a load moving system. The units are maintenance-free.

### Features

- Solid forged steel construction.
- Anti-slip rubber lining.
- Abrasion-resistant nylon wheels.
- Models LF-2.5 and above are provided with two enclosed ball bearings per wheel.

### Technical data model LF

Model	EAN-No. 4025092*	Capacity t	Wheels	Number of wheels	Wheels diameter x width mm	Dimensions L x W x H mm	Weight kg
LF-1	*163828	1.0	fixed	4	100x35	400x228x120	7.0
LF-2	*163835	2.0	fixed	8	100x35	400x228x120	8.0
LF-2,5	*163842	2.5	fixed	2	85x90	275x120x100	4.0
LF-3	*163859	3.0	fixed	4	85x85	400x228x100	9.5
LF-6	*163866	6.0	fixed	6	85x85	415x210x100	12.0



Model LF-2

Model LF-2,5

Model LF-3

Model LF-6

## Load moving skates and systems with steerable wheels model LFL

### Capacity 1 t

The components of the load moving skates can be universally combined and are ideal for the transport of medium heavy loads of all kinds.

The components can be used individually or adapted to a load moving system. The units are maintenance-free.

### Features

- Solid forged steel construction.
- Anti-slip rubber lining.
- Abrasion-resistant nylon wheels.
- Model LFL-1-2 uses two steerable and two fixed wheels.
- Model LFL-1-4 uses four steerable wheels.



Model LFL-1-2

### Technical data model LFL

Model	EAN-No. 4025092*	Capacity t	Wheels	Number of rollers	Swivel roller diameter x width mm	Fixed roller diameter x width mm	Dimensions L x W x H mm	Weight kg
LFL-1-2	*163873	1.0	2 x fixed, 2 x steerable	4	75 x 46	100 x 35	430 x 340 x 120	13.0
LFL-1-4	*163880	1.0	4 x steerable	4	75 x 46	-	430 x 340 x 120	14.0



Model LFL-1-4

# Load Moving Systems

## Heavy load moving system model LX

### Capacity 6 t and 12 t

These three point loading systems comprise of a steerable front and a pair of adjustable rear skates.

The heavy load moving systems are supplied ready-to-use.

The steerable front skates (LX-6F and LX-12F) are provided with an appropriate towing bar. The rear skates (LX-12R) are identical in construction and are equipped with two adjustable tie rods.

The wheels are made of hardwearing nylon.

The front and rear skates can accept each 50% of the total capacity.



Model LX-6

### Technical data model LX

Model	EAN-No. 4025092*	Capacity t	Number of wheels front skate	Number of wheels rear skate	Wheels diameter x width mm	Load area front skate mm	Load area rear skate mm	Adjustment range rear skates mm	Height mm	Weight kg
LX-6	*163781	6.0	4	8	85x90	185x150	300x250	500 - 1400	115	45.0
LX-12	*163798	12.0	8	8	85x90	400x220	300x250	500 - 1400	115	80.0



Model LX-12







Hydraulic cylinders,  
single-acting



Hydraulic cylinders,  
double-acting



Hand pumps



Electric motor pumps

! Please note our user instructions  
at the beginning of each chapter.

## Hydraulic jacks & tools

A characteristic of this “force-oriented” hydraulic program is the operating pressure which can be as high as 700 bar. This guarantees a simple and safe generation of highest forces. In spite of this the units remain compact, portable and easy to operate. High-pressure hydraulic systems of this type are used in universal assembly and repair operations whereby their application in day-to-day operations is almost unlimited. The component program allows the individual configuration of simple and also complex system solutions.

**They are used in the following main industrial areas:**

Heavy industry, mining, shipbuilding, offshore, aviation industries, power stations, steel construction, steel making and processing, building construction, bridge and tunnel construction, heavy steel and tank construction, metal processing workshops, and many more.

**Test rigs & Presses**



**Jacks**



**Hydraulic jacks & tools**

## Table of Contents

	Page
Hydraulic cylinders, single-acting	344 - 353
	362 - 365
Hydraulic cylinders, double-acting	354 - 361
Accessories for hydraulic cylinders	366 - 369
Hand pumps 700 bar	370 - 375
Hand pumps up to 2000 bar	376
Foot pump 700 bar	377
Electric & Pneumatic motor pumps	378 - 379
Electric hydraulic power packs	380 - 385
Valves & Accessories	386 - 399
Puller	400 - 405
Jacks	406 - 413
Hydraulic jacks & tools	414 - 415
Test rigs	416 - 417
Presses	418 - 420
Selection & Speed charts	421 - 425



## Why hydraulics?

Hydraulics is the kind of power transmission which allows the greatest density of forces. There is no other kind of power transmission that will transmit comparable high forces with the same construction size.

## Hydraulic tools

Hydraulic tools are a special type of power tools, which can be used for general assembly and repair jobs with preferably high force in lowest spaces.

Simple applications, clearness of the program in line with robustness, short-term deliveries and universal operation possibilities have made Yale hydraulic components indispensable tools also for elaborate functions.

The unlimited power of hydraulic tools is used in applications like lifting, levelling and positioning of heaviest loads, installations of machines, assembly of complex structures as well as in general repair of maintenance jobs.

The components can also be operated in fixtures for clamping, testing, pressing, extracting, crimping, cutting, riveting and many more.

## How to reach high forces in hydraulics?

area	x	pressure	=	force
effective piston area	x	system pressure	=	force
cm <sup>2</sup>	x	bar	=	daN

Example: Hydraulic cylinder YS-10/

14.3 cm <sup>2</sup>	x	700 bar	=	10010 daN
			=	100 kN
			=	10 t

## Linear conversion of pressure force

The above formula shows that pressure forces can be converted linearly.

Example:

A 10 ton cylinder presses at:

700 bar	-	100 kN	=	10 t
350 bar	-	50 kN	=	5 t
100 bar	-	14 kN	=	1.4 t
1 bar	-	0.14 kN	=	0.014 t

**The system pressure determines the force of the hydraulic cylinder. The oil displacement determines the piston travel speed.**

## Basic terms in hydraulics

### Pressure

is the system pressure generated by the pump, which, however, can also be produced by an external power source, which acts on the hydraulic cylinder.

### Force

is always the pressure transferred by the hydraulic cylinder (only with counterpressure).

### Stroke

is the travel distance to be achieved by the force (no-load stroke, loaded stroke, return stroke).

### Piston travel speed

Is the time, in which the piston of the hydraulic cylinder is to pass a certain travel distance (stroke) (no-load stroke + loaded stroke, return stroke).

### Hydraulic cylinders

are available in many different designs, however, with only two basic function principles:

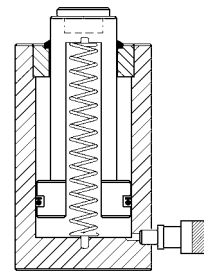

#### single-acting

The piston travel is achieved via hydraulic pressure and returned by spring activation (pressure build-up in one direction only).

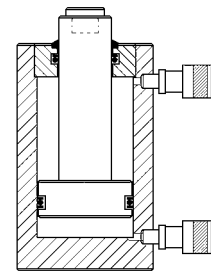

#### double-acting

The piston travel is achieved via hydraulic pressure in both directions. (Push forces and pulling forces are possible).



## Hydraulic hand pumps

The function of a hydraulic hand pump is to convey hydraulic oil (no-load stroke) and to generate pressure, which will be converted by the hydraulic cylinder into force (loaded stroke). Hydraulic hand pumps are independent from energy and can be used in every-day applications. They are easily portable and render an extremely high power generation in connection with a corresponding hydraulic cylinder.

Hand pumps require certain manpower and are often replaced by motor pumps in case of permanent duty and high oil quantities, respectively.

### Hand pumps are distinguished by:

1. oil displacement volume (1<sup>st</sup> stage / 2<sup>nd</sup> stage).
2. the function of the hydraulic cylinder: single-acting / double-acting.

### Motor pumps

transmit an oil flow as soon as the pump unit is driven by the electric motor. Contrary to hand pumps, the oil flow is also available when the hydraulic cylinder is not activated (e.g. during work breaks).



### Hydraulic valves

Valves are used in hydraulics to control the oil flow (generated by either hand or motor pump) in terms of direction, pressure and oil volume.

### Directional valves

are required to control the direction of the oil flow and thus the work motions of the connected hydraulic cylinder (advance – stop – retract).

Depending on the type of pump and cylinder, 2-, 3- or 4-way valves may be employed:

3/3-way valves for single-acting cylinders

4/3-way valves for double-acting cylinders

Controls are available with either manual or electro-magnetic valves (the latter with remote cable control).

### Pressure valves

are employed to limit the system pressure in a hydraulic system or within a part of the oil circuit. Pressure valves or pressure relief valves are also installed as safety devices in order to avoid excessive increase of the system pressure beyond a given value.

### Shut-off and throttle valves

are used to easily shut-off hydraulic lines by hand. On account of their sensible control mode, these valves can also be applied to throttle an oil flow and thus to control the piston advance at both lifting or lowering of the load.

### Safety check valves

are used for those applications where pressure drops must be avoided.

### Pressure switch

can be set to any pressure value in order to switch on/off parts of the hydraulic circuit.

## For your safety

Hydraulic units are extremely robust and durable. Nevertheless you should observe the following instructions for your own safety and to increase the life expectancy of the product:

- Never exceed the max. pressure (capacity) of the hydraulic units.
- Avoid eccentric loading of the piston.
- The load must always be positioned centric and parallel on the piston. Avoid point loading!
- Never pass under a raised load, if this is not supported additionally.
- Hydraulic units must be kept clear of heat (e.g. during welding).
- Protect hydraulic hoses against damage and strong kinks. Hydraulic hoses should lie freely in a wide curve. Avoid tensile load.

### Eccentric loading

In order to obtain a long life expectancy, hydraulic cylinders series YS, YLS, YFS, YCS, YCH, YH, and YPL are manufactured from chromium-molybdenum steel, the cylinder housings and piston rods are hardened and tempered and provided with bronze guides.

Generally, hydraulic cylinders should not be loaded eccentrically, as this can lead to reduced lifetime. In practice, a lateral loading cannot be fully avoided. In this case the maximum system pressure and the stroke of the cylinder should only be used by 50%. Ensure that the load always rests on the total area of the steel saddle and the piston, respectively. Also ensure that the entire bottom area of the hydraulic cylinder always stands on a level, sustainable ground surface. This applies especially to flat cylinders.

### Repairs

Repair and maintenance should be performed by qualified personnel only. Make sure to use original spare parts only.

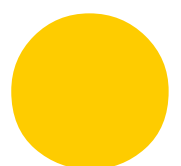



## Hydraulic cylinders with Yale Chro-Mo-Design

Yale hydraulic tools are designed for professional operation. A tool is only as good as its basic material. Therefore, our cylinders are manufactured from high quality chromium-molybdenum steel and are heat-treated.

### Double bronze bearings

Practice has shown that hydraulic cylinders used as a tool in workshops or on construction sites are frequently subjected to eccentric loading. Yale hydraulic cylinders are provided with double bronze bearings on the plunger, which minimizes friction between plunger and body during lateral loading.

### Hard chromium-plated piston

Offers excellent protection against mechanical damage and corrosion. Excellent sliding characteristics in conjunction with the upper bronze bearing in the stop ring.

### Metric mounting threads and standard parts

To facilitate the installation of hydraulic cylinders in jigs and fixtures and auxiliary structures. The metric standard throughout the entire series simplifies service operations and repairs. Cylinders carry the full load even under maximum operating pressure.

### Stop ring carries full pressure

As a safety factor the stop ring on all Yale hydraulic cylinders carries the full load even under maximum operating pressure.

### Delivered ready to use

Yale Hydraulic cylinders are delivered ready to use incl. female coupler half, hardened saddle and mounting threads; larger cylinders come with carrying handle or transportation lugs. This also applies to customised combinations which are always supplied fully assembled.

**Hardened alloy steel saddle**

**Metric mounting threads in cylinder base, plunger and cylinder collar (depending on series)**

**Two bronze bearings minimize friction even in cases of eccentric loading**

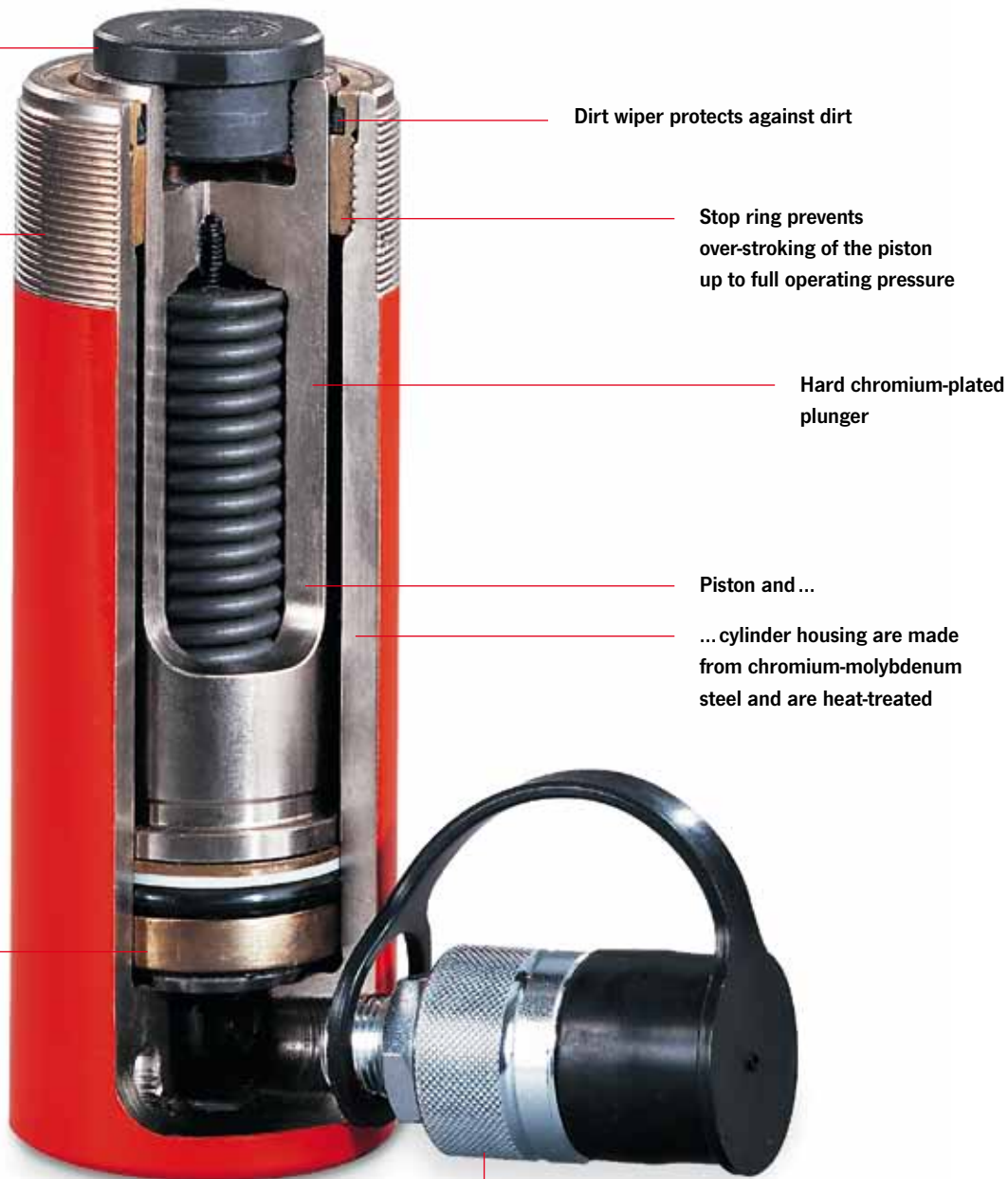

Dirt wiper protects against dirt

Stop ring prevents over-stroking of the piston up to full operating pressure

Hard chromium-plated plunger

Piston and ...  
... cylinder housing are made from chromium-molybdenum steel and are heat-treated

Female coupler half CFY-1 (incl. dust cap)

## Universal cylinder model YS

Single-acting with spring return,  
capacity 5 - 100 t

Robust construction with long guides allows the units to withstand abuse and better tolerate eccentric and side loading, yet is convenient to use with only one quick-release coupler hose connection and a spring return.

Universal cylinders are designed for all jobs where high forces but compact dimensions are required: e.g. straightening steel constructions, removing parts like shafts, axles, lifting, positioning, weighing, supporting, testing as well as for all general assembly and repair applications. Due to the various mounting threads the cylinders can easily be installed in clamping devices, welding fixtures, frame presses etc.

### Features

- Yale Chromo-Design.
- Operating pressure max. 700 bar.
- Single-acting with spring return.
- Robust design with long piston bearings to withstand eccentric loading.
- Cylinder body and piston are made from solid chromium-molybdenum steel and heat-treated.
- Hard-chromium plated piston with replaceable, heat-treated saddle.
- Metric mounting threads on cylinder collar, in the base and piston rod (5 to 30 t).
- Stop ring can bear full capacity (pressure) and is fitted with dirt wiper.
- Interchangeable hardened saddle.
- Dirt wiper protects against dirt.
- Oil port thread 3/8 NPT.
- Incl. female coupler half model CFY-1.
- Model YS-50/100 and YS-50/160 with carrying handle.
- Models YS-50/320 up to YS-100/200 with lifting rings.



**A selection chart "cylinder/hand pumps" can be found on page 421-423!**



## Technical data model YS

Cylinder size	Model	EAN-No. 4025092*	Capacity	Lift	Effective plunger area	Oil volume max.	Closed height	Cylinder outside diameter	Weight
t			kN	mm	cm <sup>2</sup>	cm <sup>3</sup>	mm	mm	kg
5	YS-5/15	*150002	50	15	7.2	11	45	41	0.9
5	YS-5/25	*150019	50	25	7.2	18	97	42	1.0
5	YS-5/75	*150026	50	75	7.2	53	157	42	1.5
5	YS-5/127	*150033	50	127	7.2	90	214	42	2.0
5	YS-5/180	*150040	50	180	7.2	127	267	42	2.4
10	YS-10/25	*150057	100	25	14.3	37	90	57	1.6
10	YS-10/50	*150064	100	50	14.3	73	125	57	2.1
10	YS-10/100	*150071	100	100	14.3	146	178	57	2.8
10	YS-10/150	*150088	100	150	14.3	218	250	57	4.1
10	YS-10/200	*150095	100	200	14.3	291	300	57	4.7
10	YS-10/250	*150101	100	250	14.3	363	352	57	5.5
10	YS-10/300	*150118	100	300	14.3	436	407	57	6.3
15	YS-15/25	*150125	150	25	21.5	53	110	67	2.7
15	YS-15/50	*150132	150	50	21.5	106	140	67	3.3
15	YS-15/100	*150149	150	100	21.5	213	190	67	4.3
15	YS-15/150	*150156	150	150	21.5	319	260	67	5.8
15	YS-15/200	*150163	150	200	21.5	425	310	67	7.0
15	YS-15/250	*150170	150	250	21.5	531	365	67	8.0
15	YS-15/300	*150187	150	300	21.5	637	420	67	9.0
15	YS-15/350	*150194	150	350	21.5	744	472	67	10.0
23	YS-23/25	*150200	230	25	32.9	83	116	85	5.0
23	YS-23/50	*150217	230	50	32.9	166	150	85	6.0
23	YS-23/100	*150224	230	100	32.9	332	202	85	7.5
23	YS-23/160	*150231	230	160	32.9	531	277	85	10.0
23	YS-23/210	*150248	230	210	32.9	697	330	85	12.0
23	YS-23/250	*150255	230	250	32.9	830	376	85	13.5
23	YS-23/300	*150262	230	300	32.9	996	428	85	15.0
23	YS-23/345	*150279	230	345	32.9	1145	477	85	16.5
30	YS-30/125	*150286	300	125	42.9	552	245	102	13.0
30	YS-30/200	*150293	300	200	42.9	884	325	102	17.0
50	YS-50/50	*150309	500	50	71.5	355	170	125	15.0
50	YS-50/100	*150316	500	100	71.5	709	220	125	19.0
50	YS-50/160	*150323	500	160	71.5	1135	285	125	24.0
50	YS-50/320	*150330	500	320	71.5	2269	460	125	37.0
70	YS-70/150	*150347	700	150	100.0	1478	285	146	32.0
70	YS-70/330	*150354	700	330	100.0	3252	490	146	52.0
100	YS-100/100	*150378	1000	100	143.0	1432	275	180	43.0
100	YS-100/200	*150361	1000	200	143.0	2863	375	180	64.0



Accessories for cylinders series YS like lifting claws, piston plates, extension tubes, support plates and threaded flanges are also available on request



Support plates are available as accessories



Threaded flanges are available as accessories

**For accessories for cylinders series YS please see pages 366-368!**

# Hydraulic Jacks & Tools Hydraulic cylinders, single-acting

## Dimensions model YS

Model	YS-5/15	YS-5/25	YS-5/75	YS-5/127	YS-5/180	YS-10/25	YS-10/50	YS-10/100	YS-10/150	YS-10/200
A, mm	45	97	157	214	267	90	125	178	250	300
B, mm	60	122	232	341	447	115	175	278	400	500
C, mm	45	92	152	209	262	88	119	172	244	294
D, mm	41	42	42	42	42	57	57	57	57	57
E, mm	30	30	30	30	30	43	43	43	43	43
F, mm	25	26	26	26	26	38	38	38	38	38
H, mm	19	19	19	19	19	17	19	19	21	21
J, mm	-	25	25	25	25	-	35	35	35	35
K, mm	-	5	5	5	5	3	6	6	6	6
O, mm	-	M20x2	M20x2	M20x2	M20x2	-	M27x2	M27x2	M27x2	M27x2
P, mm	-	13	13	13	13	-	17	17	22	22
S, mm	-	-	-	-	-	-	-	-	-	-
U, mm	28.5	28	28	28	28	35	35	35	35	35
V, mm	2x5.5 Ø	2xM6	2xM6	2xM6	2xM6	2xM8	2xM8	2xM8	2xM8	2xM8
W, mm	-	23	23	23	23	27	27	27	27	27
X, mm	-	M42x1.5	M42x1.5	M42x1.5	M42x1.5	M57x1.5	M57x1.5	M57x1.5	M57x1.5	M57x1.5
Z, °	5	5	5	5	5	5	5	5	-	-

Model	YS-10/250	YS-10/300	YS-15/25	YS-15/50	YS-15/100	YS-15/150	YS-15/200	YS-15/250	YS-15/300	YS-15/350
A, mm	352	407	110	140	190	260	310	365	420	472
B, mm	602	707	135	190	290	410	510	615	720	822
C, mm	346	401	103	133	183	253	303	358	413	465
D, mm	57	57	67	67	67	67	67	67	67	67
E, mm	43	43	52	52	52	52	52	52	52	52
F, mm	38	38	46	46	46	46	46	46	46	46
H, mm	21	21	19	19	19	22	22	22	22	22
J, mm	35	35	40	40	40	40	40	40	40	40
K, mm	6	6	7	7	7	7	7	7	7	7
O, mm	M27x2	M27x2	M33x2	M33x2	M33x2	M33x2	M33x2	M33x2	M33x2	M33x2
P, mm	22	22	19	19	19	25	25	25	25	25
S, mm	-	-	-	-	-	-	-	-	-	-
U, mm	35	35	42	42	42	42	42	42	42	42
V, mm	2xM8	2xM8	2xM10	2xM10	2xM10	2xM10	2xM10	2xM10	2xM10	2xM10
W, mm	27	27	33	33	33	33	33	33	33	33
X, mm	M57x1.5	M57x1.5	M67x1.5	M67x1.5	M67x1.5	M67x1.5	M67x1.5	M67x1.5	M67x1.5	M67x1.5
Z, °	-	-	5	5	5	-	-	-	-	-

Model	YS-23/25	YS-23/50	YS-23/100	YS-23/160	YS-23/210	YS-23/250	YS-23/300	YS-23/345	YS-30/125	YS-30/200
A, mm	116	150	202	277	330	376	428	477	245	325
B, mm	141	200	302	437	540	626	728	822	370	525
C, mm	113	142	194	269	322	368	420	469	235	315
D, mm	85	85	85	85	85	85	85	85	102	102
E, mm	65	65	65	65	65	65	65	65	75	75
F, mm	56	56	56	56	56	56	56	56	65	65
H, mm	20	22	22	22	22	22	22	22	25	25
J, mm	50	50	50	50	50	50	50	50	50	50
K, mm	3	8	8	8	8	8	8	8	10	10
O, mm	M40x2	M40x2	M40x2	M40x2	M40x2	M40x2	M40x2	M40x2	M36x2	M36x2
P, mm	15	22	22	25	25	25	25	25	25	25
S, mm	-	-	-	-	-	-	-	-	-	-
U, mm	55	55	55	55	55	55	55	55	75	75
V, mm	4xM10	4xM10	4xM10	4xM10	4xM10	4xM10	4xM10	4xM10	4xM10	4xM10
W, mm	40	40	40	40	40	40	40	40	45	45
X, mm	M85x2	M85x2	M85x2	M85x2	M85x2	M85x2	M85x2	M85x2	M102x2	M102x2
Z, °	5	-	-	-	-	-	-	-	-	-



## Dimensions model YS

Model	YS-50/50	YS-50/100	YS-50/160	YS-50/320	YS-70/150	YS-70/330	YS-100/100	YS-100/200
A, mm	170	220	285	460	285	490	275	375
B, mm	220	320	445	780	435	820	375	575
C, mm	165	215	280	455	280	485	270	370
D, mm	125	125	125	125	146	146	180	180
E, mm	95	95	95	95	112	112	135	135
F, mm	85	85	85	85	95	95	115	115
H, mm	29	29	29	29	30	30	60	60
J, mm	70	70	70	70	80	80	100	100
K, mm	5	5	5	5	5	5	5	5
O, mm	4xM8	4xM8	4xM8	4xM8	4xM8	4xM8	4xM10	4xM10
P, mm	-	-	-	-	-	-	-	-
S, mm	-	51	51	24	24	24	24	24
U, mm	95	95	95	95	110	110	145	145
V, mm	4xM12	4xM12	4xM12	4xM12	4xM12	4xM12	4xM12	4xM12
W, mm	50	50	50	50	60	60	70	70
X, mm	M125x2	M125x2	M125x2	M125x2	M146x3	M146x3	M180x3	M180x3
Z, °	-	-	-	-	-	-	-	-

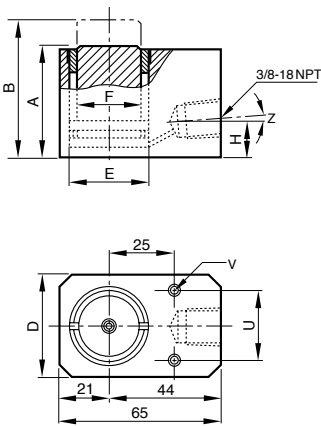

Model YS-5/15

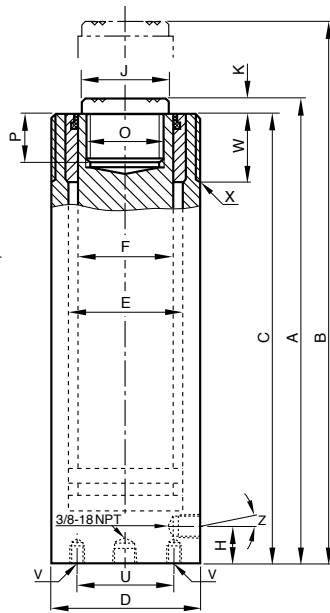

Model YS-5/25 up to YS-30/200

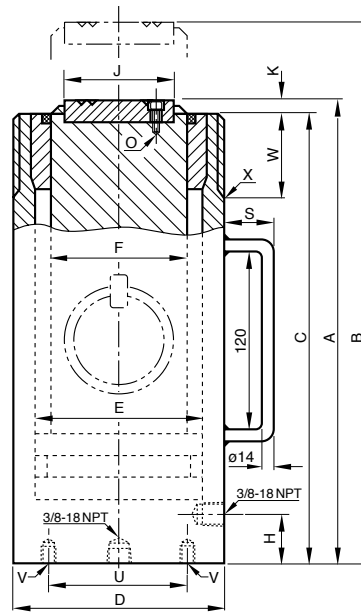

Model YS-50/50 up to YS-100/200

**!** Subject to changes.

## Low-height and flat cylinders model YLS and model YFS

Single-acting with spring return, capacity max. 10 - 100 t

Low-height cylinders are recommended for all lifting, pushing, levelling, pressing applications especially in tight working areas.

These very compact hydraulic cylinders are designed for lifting and positioning jobs as well as all general maintenance applications, where low height, portability and light weight are needed. These versatile cylinders are found in all industrial areas like steel mills, civil engineering, heavy construction industry, power plants, off-shore industries etc. Due to their short strokes flat cylinders should not be subjected to side loading.

### Features

- Yale ChroMo-Design.
- Operating pressure max. 700 bar.
- Single-acting with spring return.
- Low height for tight working areas.
- Cylinder body and piston are made from solid chromium-molybdenum steel and heat-treated.
- Stop ring can bear full capacity (pressure) and is fitted with dirt wiper.
- Oil port thread 3/8 NPT.
- Incl. female coupler half model CFY-1.
- Model YLS-100/55 is equipped with two lifting rings model YFS-100/15 comes with a carrying handle.



YLS

**A selection chart "cylinder/hand pumps" can be found on page 421-423.**



YFS

## Technical data model YLS

Cylinder size	Model	EAN-No. 4025092*	Capacity max.	Lift	Effective plunger area	Oil volume max.	Closed height	Cylinder outside diameter	Weight
t			kN	mm	cm <sup>2</sup>	cm <sup>3</sup>	mm	mm	kg
10	YLS-10/35	*150804	100	35	14.3	51	86	70	2.5
20	YLS-20/45	*150811	200	45	28.6	128	100	85	4.0
30	YLS-30/60	*150828	300	60	42.9	266	120	100	6.5
50	YLS-50/60	*150835	500	60	71.5	426	122	125	10.4
100	YLS-100/55	*150842	1000	55	143.0	788	141	170	24.0

## Technical data model YFS

Cylinder size	Model	EAN-No. 4025092*	Capacity max.	Lift	Effective plunger area	Oil volume max.	Closed height	Cylinder outside diameter	Weight
t			kN	mm	cm <sup>2</sup>	cm <sup>3</sup>	mm	mm	kg
10	YFS-10/11	*150750	100	11	14.3	16	43	56	1.5
20	YFS-20/15	*150767	200	15	28.6	31	60	76	3.0
30	YFS-30/15	*150774	300	15	44.2	66	60	96	4.2
50	YFS-50/15	*150781	500	15	71.5	107	70	145	8.7
100	YFS-100/15	*150798	1000	15	143.0	215	91	170	16.0

## Dimensions model YLS and model YFS

Model	YLS-10/35	YLS-20/45	YLS-30/60	YLS-50/60	YLS-100/55	YFS-10/11	YFS-20/15	YFS-30/15	YFS-50/15	YFS-100/15
A, mm	86	100	120	122	141	43	60	60	70	91
B, mm	121	145	180	182	196	54	75	75	85	106
D, mm	70	85	100	125	170	56	76	96	145	170
D1, mm	-	-	-	-	-	83	95	115	-	-
E, mm	43	60	75	95	135	43	60	75	95	135
F, mm	38	50	57	75	120	38	50	57	75	120
H, mm	16	17	19	19	26	16	19	19	19	22
M, mm	-	-	-	-	148	-	-	-	-	85
Q, mm	-	-	-	-	-	28	38	48	-	-
R, mm	54	54	54	54	54	54	54	54	54	54
S, mm	-	-	-	-	25	-	-	-	-	55
Z, °	10	10	5	5	-	10	5	5	5	-

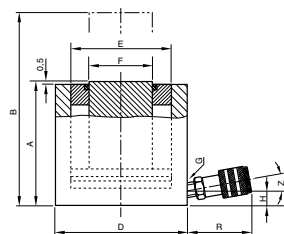

YLS

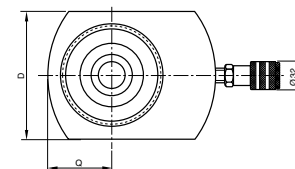
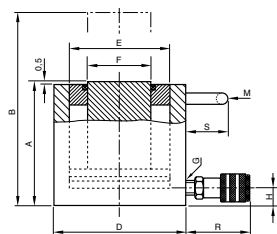

YFS

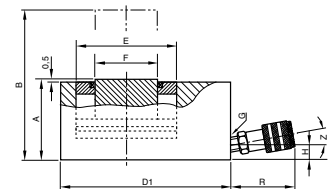



**A selection chart "cylinder/hand pumps" can be found on page 421-423.**

### Pull cylinder model YPL

Single-acting with spring return, capacity max. 10 - 51 t

Pull cylinders are able to produce extremely high pulling forces and can be controlled precisely by the use of hand pumps or power packs. In neutral position pull cylinders are fully extended. As soon as the cylinders are pressurized the forged links are drawn together. A built-in return spring extends the piston again as soon as the pressure is released.

Shipbuilding, heavy-vessel construction, steel construction, civil engineering as well as general repair and maintenance applications.

#### Features

- Yale ChroMo-Design.
- Operating pressure max. 700 bar.
- Single-acting with spring return.
- Can be operated in all positions (except model YPPS).
- Cylinder body and piston are made from solid chromium-molybdenum steel and heat-treated.
- Hard-chromium plated piston with replaceable, heat-treated saddle.
- Stop ring can bear full capacity (pressure) and is fitted with dirt wiper.
- Forged, replaceable links.
- With carrying handle and piston protection cover.
- Oil port thread 3/8 NPT.
- Incl. female coupler half model CFY-1.
- The pull cylinder model YPPS-10/150 is equipped with an integrated hand pump similar to model HPS-2/0.7 A.

**A travel-speed chart is supplied on page 424-425.**

## Technical data model YPL

Cylinder size	Model	EAN-No. 4025092*	Capacity max.	Lift	Effective plunger area	Oil volume max.	Length between links mm	Weight
t			kN	mm	cm <sup>2</sup>	cm <sup>3</sup>		kg
10	YPL-10/150	*152822	100	150	14.2	213	750	9
20	YPL-20/150	*152839	200	150	30.6	459	795	22
30	YPL-30/150	*152846	300	150	42.6	639	875	29
51	YPL-51/150	*157858	510	150	74.6	1120	955	59
10	YPPS-10/150	*161909	100	150	14.2	213	750	19

## Dimensions model YPL

Model	YPL-10/150	YPL-20/150	YPL-30/150	YPL-51/150	YPPS-10/150
A, mm	749	795	875	955	749
B, mm	78	95	120	150	78
C, mm	32	35	56	70	32
D, mm	68	105	121	156	68
E, mm	120	120	150	150	120
G, mm	23	30	32	40	23
H, mm	M24x1.5	M45x2	M50x2	M60x2	M24x1.5

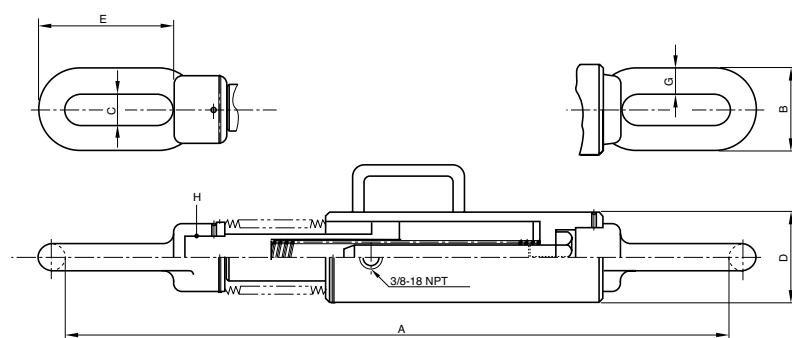



**A selection chart “cylinder/hand pumps” can be found on page 421-423.**

## Hollow cylinders model YCS

Single-acting with spring return, capacity 12 - 93 t

Due to the centre hole design a threaded rod can be placed through the hollow cylinders so that extremely high pulling forces can be achieved.

Hollow cylinders are used as the power component within hydraulic puller sets, for prestressing anker bolts, removing axles, shafts, bushings, extracting tubes, as well as for heavy-duty pulling applications.

### Features

- Yale ChroMo-Design.
- Operating pressure max. 700 bar.
- Single-acting with spring return.
- With large centre hole diameter.
- Cylinder body and piston are made from solid chromium-molybdenum steel and heat-treated.
- Hard-chromium plated piston with replaceable, heat-treated saddle.
- Metric mounting threads at cylinder body and inside of piston.
- Stop ring prevents overtravel of the piston up to full operating pressure.
- Interchangeable hardened saddle.
- With inner and outer dirt wipers.
- Oil port thread 3/8 NPT.
- Incl. female coupler half model CFY-1.
- From model YCS-21/150 with carrying handle.
- From model YCS-57/70 with two lifting rings.



## Function principal of the hollow cylinders

In connection with threaded rods hollow cylinders can produce extremely high forces which are helpful for various repair or assembly applications like removing press-fitted parts, prestressing anchors etc.

In addition, hollow cylinders are used as power source in puller sets and test rigs. By the use of long threaded rods and by readjusting the nut larger distances can be pulled even when using short cylinder strokes.

## Technical data model YCS

Cylinder size	Model	EAN-No. 4025092*	Capacity	Lift	Effective plunger area	Oil volume max.	Closed height	Centre hole diameter	Cylinder outside diameter	Weight
t			kN	mm	cm <sup>2</sup>	cm <sup>3</sup>	mm	mm	mm	kg
12	YCS-12/40	*150873	120	40	17.2	71	142	20	70	3.5
12	YCS-12/75	*150880	120	75	17.2	132	195	20	70	4.5
21	YCS-21/50	*150897	214	50	30.5	153	173	27	100	8.5
21	YCS-21/150	*150903	214	150	30.5	458	335	27	100	15.0
33	YCS-33/60	*150910	335	60	47.9	287	193	33	114	12.0
33	YCS-33/150	*150927	335	150	47.9	716	343	33	114	21.0
57	YCS-57/70	*150934	567	70	81.0	562	242	42	150	25.0
62	YCS-62/150	*150941	618	150	88.3	1330	335	55	163	38.0
93	YCS-93/75	*150958	930	75	133	990	280	80	214	55.0

## Dimensions model YCS

Model	YCS-12/40	YCS-12/75	YCS-21/50	YCS-21/150	YCS-33/60	YCS-33/150	YCS-57/70	YCS-62/150	YCS-93/75
A, mm	135	188	163	325	183	333	230	323	265
B, mm	175	263	213	475	243	483	300	473	340
C, mm	20	20	27	27	33	33	42	55	80
D, mm	70	70	100	100	114	114	150	163	214
E, mm	55	55	73	73	90	90	118	130	170
F, mm	40	40	53	53	65	65	90	100	136
J, mm	38	38	50	50	62	62	85	96	132
K, mm	3	3	3	3	3	3	3	3	5
M, mm	-	-	-	120	-	120	-	-	-
O, mm	M30x1.5	M30x1.5	M40x1.5	M40x1.5	M48x1.5	M48x1.5	M65x2	M78x2	M115x2
P, mm	20	20	25	25	30	30	35	40	45
R, mm	4	4	5	5	5	5	5	5	-
S, mm	-	-	-	51	-	51	24	24	24
T, mm	-	-	-	-	-	-	155	200	170
U, mm	58	58	82	82	92	92	120	135	180
V, mm	2xM8	2xM8	2xM10	2xM10	4xM10	4xM10	4xM12	4xM12	4xM16
W, mm	30	30	35	35	40	40	50	60	-
X, mm	M70x2	M70x2	M100x2	M100x2	M110x2	M110x2	M150x3	M160x3	-
Y, mm	7	7	10	10	10	10	12	12	15

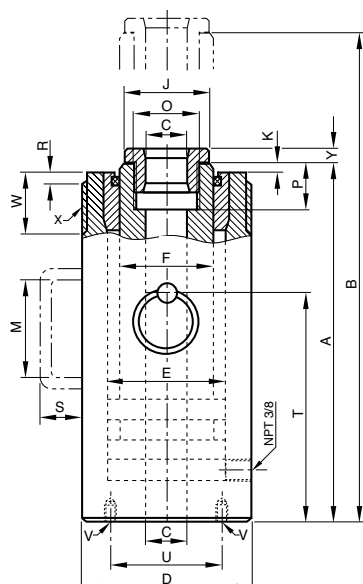





**On request we supply special hollow cylinders with pulling capacities up to 600 tons.**

### Hollow cylinders model YCH

**Double-acting with hydraulic return,  
capacity 33 - 140 t**

Basically, the applications are the same as for the single-acting hollow cylinders shown on the opposite page, but for this model range the return of the piston is done hydraulically by means of the second oil port. These double-acting hollow cylinders are used when the piston needs to be retracted quickly e.g. with high-cycle pulling applications.

#### Features

- Yale ChroMo-Design.
- Operating pressure max. 700 bar.
- Double-acting with hydraulic return.
- With large centre hole diameter.
- Cylinder body and piston are made from solid chromium-molybdenum steel and heat-treated.
- Hard-chromium plated piston with replaceable, heat-treated saddle.
- Metric mounting threads at cylinder body and inside of piston.
- Stop ring prevents overtravel of the piston up to full operating pressure.
- Interchangeable hardened saddle.
- With inner and outer dirt wipers.
- Oil port thread 3/8 NPT.
- Incl. 2 female coupler halves model CFY-1.
- All cylinders with carrying handle, from model YCH-62/250 with 2 lifting rings.

**A selection chart “cylinder/hand pumps”  
can be found on page 421-423.**

## Technical data model YCH

Cylinder size	Model	EAN-No. 4025092*	Capacity push	Capacity pull	Lift	Effective plunger area	Oil volume max.	Closed height	Centre hole diameter	Cylinder outside diameter	Weight
t			kN	kN	mm	cm <sup>2</sup>	cm <sup>3</sup>	mm	mm	mm	kg
33	YCH-33/150	*150965	335	180	150	47.9	716	310	33	114	19
33	YCH-33/250	*150972	335	180	250	47.9	1200	415	33	114	25
62	YCH-62/250	*150989	618	300	250	88.3	2220	452	55	163	55
93	YCH-93/250	*150996	930	450	250	133.0	3320	465	55	193	82
100	YCH-100/40	*151009	1000	500	40	143.0	578	190	55	200	38
140	YCH-140/200	*151016	1400	700	200	200.2	4080	383	80	253	115

For double-acting hollow cylinders the "capacity push" is equivalent to the max. pulling force achieved with tensioning anchor or threaded spindle.

## Dimensions model YCH

Model	YCH-33/150	YCH-33/250	YCH-62/250	YCH-93/250	YCH-100/40	YCH-140/200
A, mm	300	405	440	450	175	365
B, mm	450	655	690	700	215	565
C, mm	33	33	55	55	55	80
D, mm	114	114	163	193	200	253
E, mm	90	90	130	150	155	195
F, mm	67	67	105	120	125	160
J, mm	62	62	96	110	110	145
K, mm	3	3	5	5	5	5
M, mm	120	120	-	-	-	-
O, mm	M48x1.5	M48x1.5	M78x2	M85x2	M85x2	M115x2
P, mm	30	30	40	45	45	50
R, mm	5	5	5	5	-	-
S, mm	51	51	24	30	24	30
T, mm	-	-	290	290	115	240
U, mm	92	92	135	160	165	210
V, mm	4xM10	4xM10	4xM12	4xM16	4xM16	4xM16
W, mm	40	40	50	65	-	-
X, mm	M110x2	M110x2	M160x3	M190x3	-	-
Y, mm	10	10	12	15	15	18

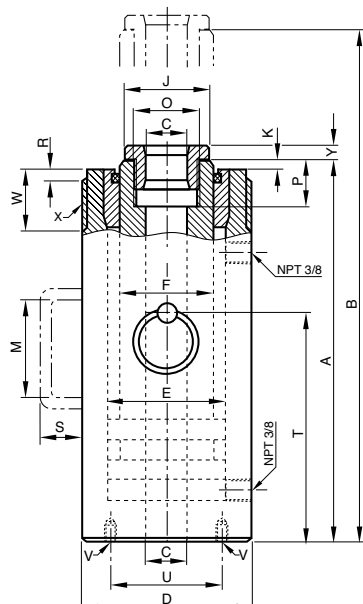



## Universal cylinders model YH

Double-acting with hydraulic return,  
capacity 5 - 200 t

These extremely robust double-acting cylinders are especially designed for universal heavy-duty lifting and positioning applications as well as for industrial production and assembly jobs. The cylinders offer high pushing and pulling forces. The double-acting design assures a high piston retraction speed.

Major areas of application are bridge building and civil engineering, off-shore, ship building, etc. They can also be used as power source in frame presses, stamping fixtures and other industrial uses where high pushing and pulling forces are required.

### Features

- Yale ChroMo-Design.
- Operating pressure max. 700 bar.
- Double-acting with hydraulic return.
- Long bronze piston guidings.
- Piston strokes from 30 up to 500 mm.
- Cylinder body and piston are made from solid chromium-molybdenum steel and heat-treated.
- Double bronze bearing of the hard chromium plated piston.
- Metric mounting threads on cylinder housing, in the bottom of the cylinder body and in the piston rod.
- Stop ring can bear full capacity (pressure) and is fitted with dirt wiper.
- Interchangeable hardened saddle.
- Dirt wiper protects against dirt.
- Oil port thread 3/8 NPT.
- Incl. 2 female coupler halves model CFY-1.
- From model YH-30/200 with carrying handle.
- From model YH-50/350 with 2 lifting rings.

! A selection chart "cylinder/hand pumps"  
can be found on page 421-423.

## Technical data model YH

Cylinder size	Model	EAN-No. 4025092*	Capacity push	Capacity pull	Lift	Effective plunger area push	Effective plunger area pull	Oil volume max.	Closed height	Cylinder outside diameter	Weight
t			kN	kN	mm	cm <sup>2</sup>	cm <sup>2</sup>	cm <sup>3</sup>	mm	mm	kg
5	YH-5/30	*150408	50	22	30	7.2	3.1	21	160	55	2.5
5	YH-5/80	*150415	50	22	80	7.2	3.1	57	210	55	3.3
5	YH-5/150	*150422	50	22	150	7.2	3.1	106	280	55	4.4
10	YH-10/30	*150439	100	45	30	14.3	6.4	44	175	67	4.0
10	YH-10/80	*150446	100	45	80	14.3	6.4	116	225	67	5.0
10	YH-10/150	*150453	100	45	150	14.3	6.4	218	295	67	6.7
10	YH-10/250	*150460	100	45	250	14.3	6.4	363	395	67	9.0
20	YH-20/50	*150477	200	100	50	28.6	14.3	142	195	85	7.0
20	YH-20/150	*150484	200	100	150	28.6	14.3	424	310	85	11.0
20	YH-20/250	*150491	200	100	250	28.6	14.3	707	410	85	14.0
30	YH-30/200	*150507	300	140	200	42.9	20.0	884	355	102	19.0
30	YH-30/350	*150514	300	140	350	42.9	20.0	1547	510	102	27.0
50	YH-50/150	*150521	500	220	150	71.5	31.5	1064	325	125	27.0
50	YH-50/350	*150538	500	220	350	71.5	31.5	2481	525	125	42.0
50	YH-50/500	*150545	500	220	500	71.5	31.5	3544	685	125	52.0
70	YH-70/150	*150552	700	330	150	100.0	47.2	1478	335	146	37.0
70	YH-70/350	*150569	700	330	350	100.0	47.2	3449	540	146	56.0
100	YH-100/50	*150576	1000	450	50	143.0	64.4	716	265	180	49.0
100	YH-100/150	*150583	1000	450	150	143.0	64.4	2148	365	180	64.0
100	YH-100/350	*150590	1000	450	350	143.0	64.4	5010	565	180	94.0
100	YH-100/500	*150606	1000	450	500	143.0	64.4	7157	725	180	118.0
200	YH-200/150	*150613	2000	900	150	286.0	128.7	4253	410	250	137.0
200	YH-200/350	*150620	2000	900	350	286.0	128.7	9924	620	250	198.0
200	YH-200/500	*150637	2000	900	500	286.0	128.7	14177	780	250	244.0

For cylinders series YH accessories please see pages 368-369.

# Hydraulic Jacks & Tools Hydraulic cylinders, double-acting

## Dimensions model YH

Model	YH-5/30	YH-5/80	YH-5/150	YH-10/30	YH-10/80	YH-10/150	YH-10/250	YH-20/50	YH-20/150	YH-20/250	YH-30/200	YH-30/350
A, mm	160	210	280	175	225	295	395	195	310	410	355	510
B, mm	190	290	430	205	305	445	645	245	460	660	555	860
C, mm	138	188	258	150	200	270	370	167	282	382	345	500
D, mm	55	55	55	67	67	67	67	85	85	85	102	102
E, mm	30	30	30	43	43	43	43	60	60	60	75	75
F, mm	22.4	22.4	22.4	32	32	32	32	42	42	42	55	55
H, mm	31	31	31	35	35	35	35	22	37	37	46	46
I, mm	44	44	44	50	50	50	50	59	59	59	64	64
J, mm	-	-	-	-	-	-	-	-	-	-	50	50
K, mm	4	4	4	5	5	5	5	5	5	5	10	10
L, mm	17	17	17	20	20	20	20	-	22	22	28	28
O, mm	M18x1.5	M18x1.5	M18x1.5	M27x2	M27x2	M27x2	M27x2	M36x2	M36x2	M36x2	M36x2	M36x2
P, mm	18	18	18	20	20	20	20	23	23	23	28	28
S, mm	-	-	-	-	-	-	-	-	-	-	51	51
U, mm	-	-	-	-	-	-	-	-	-	-	-	-
V, mm	M27x2	M27x2	M27x2	M36x2	M36x2	M36x2	M36x2	-	M45x2	M45x2	M36x2	M36x2
W, mm	27	27	27	33	33	33	33	40	40	40	45	45
X, mm	M55x1.5	M55x1.5	M55x1.5	M67x1.5	M67x1.5	M67x1.5	M67x1.5	M85x2	M85x2	M85x2	M102x2	M102x2

Model	YH-50/150	YH-50/350	YH-50/500	YH-70/150	YH-70/350	YH-100/50	YH-100/150	YH-100/350	YH-100/500	YH-200/150	YH-200/350	YH-200/500
A, mm	325	525	685	335	540	265	365	565	725	410	620	780
B, mm	475	875	1185	485	890	315	515	915	1225	560	970	1280
C, mm	313	513	673	321	526	250	350	550	710	391	601	761
D, mm	125	125	125	146	146	180	180	180	180	250	250	250
E, mm	95	95	95	112	112	135	135	135	135	190	190	190
F, mm	70	70	70	80	80	100	100	100	100	140	140	140
H, mm	55	55	55	58	58	66	66	66	66	80	80	80
I, mm	70	70	70	79	79	90	90	90	95	105	105	105
J, mm	65	65	65	75	75	90	90	90	90	127	127	127
K, mm	12	12	12	14	14	15	15	15	15	19	19	19
L, mm	31	31	31	35	35	-	-	-	-	-	-	-
O, mm	M45x2	M45x2	M45x2	M50x3	M50x3	M65x3	M65x3	M65x3	M65x3	M90x3	M90x3	M90x3
P, mm	31	31	31	35	35	40	40	40	40	55	55	55
S, mm	51	24	24	24	24	24	24	30	30	30	30	30
U, mm	-	-	-	-	-	110	110	110	110	160	160	160
V, mm	M45x2	M45x2	M45x2	M50x3	M50x3	4xM12	4xM12	4xM12	4xM12	4xM16	4xM16	4xM16
W, mm	50	50	50	60	60	70	70	70	70	80	80	80
X, mm	M125x2	M125x2	M125x2	M146x3	M146x3	M180x3	M180x3	M180x3	M180x3	M250x4	M250x4	M250x4

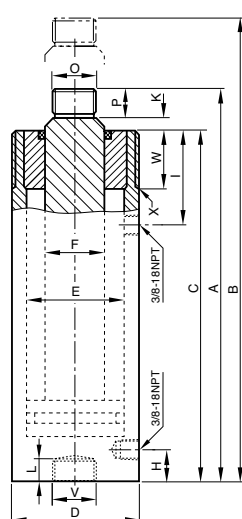

Model YH-5/30 up to YH 20/250

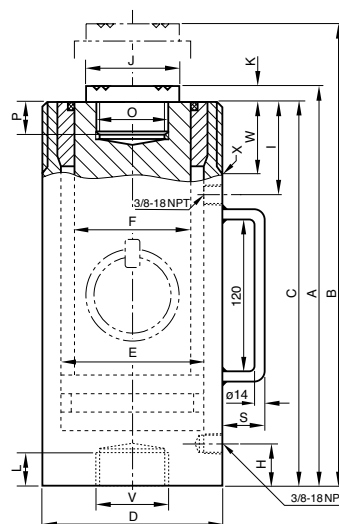

Model YH-30/200 up to YH 70/350

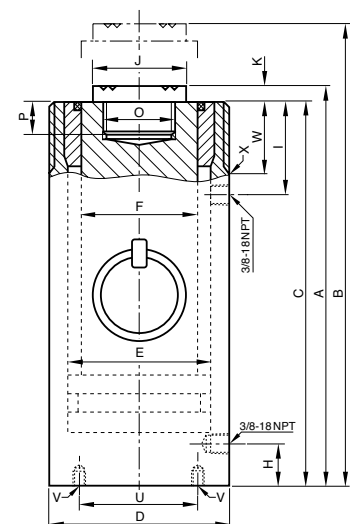

Model YH-100/50 up to YH 200/500





## High-tonnage cylinders model YEHA

Double-acting with hydraulic return,  
capacity max. 140 - 1100 t

Cylinders of series YEHA are normally used for lifting, positioning or handling heavy loads. The double-acting function allows a faster piston return, even with longer hydraulic hoses.

Lifting and moving of large machinery, steel construction, bridges or similar loads, supporting of buildings and foundations.

Further applications are positioning, weighing, through pressing, stress testing or jacking of all kinds of loads.

### Features

- Operating pressure max. 700 bar.
- Double-acting with hydraulic return.
- Generous guiding bands ensure a robust piston guiding.
- Hard chromium-plated piston.
- Stop ring as piston end stop.
- Interchangeable hardened saddle.
- Dirt wiper protects against dirt.
- Oil port thread 3/8 NPT.
- Incl. 2 female coupler halves model CFY-1.
- Mounting threads on request.
- All cylinders have lifting rings.



**A selection chart “cylinder/hand pumps”  
can be found on page 421-423.**

**A travel-speed chart is supplied  
on page 424-425.**



## Technical data model YEHA

Cylinder size	Model	EAN-No. 4025092*	Capacity max.	Lift	Effective plunger area	Oil volume max.	Closed height	Cylinder outside diameter	Weight
t			kN	mm	cm <sup>2</sup>	cm <sup>3</sup>	mm	mm	kg
140	YEHA-140/50	*162937	1400	50	201	1005	201	200	44
140	YEHA-140/100	*162920	1400	100	201	2010	251	200	51
140	YEHA-140/150	*162944	1400	150	201	3015	306	200	59
140	YEHA-140/200	*162951	1400	200	201	4020	356	200	66
140	YEHA-140/300	*162975	1400	300	201	6030	461	200	81
220	YEHA-220/50	*162982	2200	50	314	1570	216	250	75
220	YEHA-220/100	*162999	2200	100	314	3140	266	250	86
220	YEHA-220/150	*163002	2200	150	314	4710	326	250	101
220	YEHA-220/300	*163033	2200	300	314	9425	486	250	139
340	YEHA-340/50	*163125	3430	50	491	2453	231	310	127
340	YEHA-340/100	*163132	3430	100	491	4906	281	310	148
340	YEHA-340/150	*163149	3430	150	491	7360	341	310	175
340	YEHA-340/300	*163170	3430	300	491	14700	501	310	243
430	YEHA-430/50	-	4226	50	616	3079	248	340	164
430	YEHA-430/100	-	4226	100	616	6158	294	340	188
430	YEHA-430/150	-	4226	150	616	9236	353	340	215
430	YEHA-430/250	-	4226	300	616	18474	508	340	293
560	YEHA-560/50	-	5620	50	804	4019	268	390	234
560	YEHA-560/100	*163446	5620	100	804	8038	318	390	286
560	YEHA-560/150	*163439	5620	150	804	12058	373	390	301
560	YEHA-560/300	-	5620	300	804	24130	538	390	406
670	YEHA-670/50	-	6603	50	962	4811	283	430	304
670	YEHA-670/100	-	6603	100	962	9621	333	430	343
670	YEHA-670/150	-	6603	150	962	14432	398	430	400
670	YEHA-670/300	-	6603	300	962	28866	558	430	529
880	YEHA-880/50	-	8790	50	1257	6280	310	490	434
880	YEHA-880/100	-	8790	100	1257	12560	360	490	485
880	YEHA-880/150	-	8790	150	1257	18840	420	490	551
880	YEHA-880/300	-	8790	300	1257	37700	580	490	719
1100	YEHA-1100/50	-	11000	50	1590	7949	330	550	584
1100	YEHA-1100/100	-	11000	100	1590	15896	380	550	648
1100	YEHA-1100/150	-	11000	150	1590	23845	440	550	731
1100	YEHA-1100/300	-	11000	300	1590	47700	600	550	943

For tilt saddles for cylinders please see pages 364-365.

### Hydraulic cylinders with safety lock nut model YEL

Single-acting, gravity return  
capacity max. 30 - 1100 t

Hydraulic cylinders with safety lock nut are recommended when loads have to remain in the lifted position over a period of time. The safety lock nut ensures a positive load hold in any position, and work can be carried out beneath the lifted load. Hydraulic pressure can be released so that cylinders work like mechanical supports. Pumps can be separated from cylinders.

Lifting and moving of large machinery, steel construction, bridges or similar loads, supporting of buildings and foundations.

For all heavy-duty jacking applications where a special safety factor is appropriate like lifting and lowering bridges, supporting buildings and foundations, jacking up heavy machines, steel sections, ship modules or similar loads.

#### Features

- Operating pressure max. 700 bar.
- Single-acting, gravity return.
- Generous guiding bands ensure a robust piston guiding.
- Hard chromium-plated piston with trapezoidal thread.
- Overflow hole ensures a definite piston end stop.
- Interchangeable hardened saddle.
- Oil port thread 3/8 NPT.
- Incl. female coupler half model CFY-1.
- All cylinders have lifting rings.



**A travel-speed chart is supplied on page 424-425.**



**For tilt saddles for cylinders please see pages 364-365.**

## Technical data model YEL

Cylinder size	Model	EAN-No. 4025092*	Capacity max.	Lift	Effective plunger area	Oil volume max.	Closed height	Cylinder outside diameter	Weight
t			kN	mm	cm <sup>2</sup>	cm <sup>3</sup>	mm	mm	kg
30	YEL-30/50	*151894	300	50	44.2	221	169	100	10.5
30	YEL-30/100	*151900	300	100	44.2	442	219	100	13.5
30	YEL-30/150	*151917	300	150	44.2	663	269	100	17.5
30	YEL-30/200	–	300	200	44.2	885	319	100	19.5
30	YEL-30/300	*162074	300	300	44.2	1325	419	100	26.0
50	YEL-50/50	*151924	486	50	70.8	355	185	125	17.5
50	YEL-50/100	*151931	486	100	70.8	710	235	125	22.0
50	YEL-50/150	*151948	486	150	70.8	1063	285	125	30.0
50	YEL-50/200	*187930	486	200	70.8	1420	335	125	32.0
50	YEL-50/300	–	486	300	70.8	2130	435	125	41.0
100	YEL-93/50	*151955	931	50	133	663	200	180	40.0
100	YEL-93/100	*151962	931	100	133	1327	250	180	48.5
100	YEL-93/150	*151979	931	150	133	1989	300	180	58.5
100	YEL-93/200	*163637	931	200	133	2654	350	180	68.5
100	YEL-93/300	–	931	300	133	3980	450	180	83.5
140	YEL-140/50	*151986	1400	50	201	1005	211	215	60.0
140	YEL-140/100	*151993	1400	100	201	2010	259	215	72.5
140	YEL-140/150	*152006	1400	150	201	3015	309	215	88.0
140	YEL-140/200	*040327	1400	200	201	4020	359	215	102.0
140	YEL-140/300	–	1400	300	201	6030	459	215	130.0
220	YEL-220/50	*152013	2200	50	314	1570	245	265	105.0
220	YEL-220/100	*152020	2200	100	314	3140	295	265	148.0
220	YEL-220/150	*152037	2200	150	314	4710	395	265	189.0
220	YEL-220/250	*163545	2200	250	314	7850	445	265	213.0
340	YEL-340/50	*163965	3370	50	491	2453	275	330	183.0
340	YEL-340/100	*055536	3370	100	491	4906	345	330	229.0
340	YEL-340/150	*162418	3370	150	491	7360	395	330	263.0
340	YEL-340/250	–	3370	250	491	12300	495	330	329.0
430	YEL-430/50	*152051	4226	50	615	3078	335	380	296.0
430	YEL-430/100	*152068	4226	100	615	6157	385	380	340.0
430	YEL-430/150	*152075	4226	150	615	9232	435	380	385.0
430	YEL-430/250	–	4226	250	615	15400	535	380	473.0
560	YEL-560/50	–	5520	50	804	4019	375	430	390.0
560	YEL-560/100	–	5520	100	804	8038	425	430	481.0
560	YEL-560/150	*161350	5520	150	804	12058	475	430	537.0
560	YEL-560/250	–	5520	250	804	20100	575	430	650.0
670	YEL-670/50	–	6603	50	961	4809	395	475	545.0
670	YEL-670/100	–	6603	100	961	9621	445	475	614.0
670	YEL-670/150	–	6603	150	961	14425	495	475	683.0
670	YEL-670/250	–	6603	250	961	24100	595	475	821.0
880	YEL-880/50	–	8625	50	1256	6280	455	540	714.0
880	YEL-880/100	–	8625	100	1256	12560	505	540	901.0
880	YEL-880/150	–	8625	150	1256	18840	555	540	1008.0
880	YEL-880/250	–	8625	250	1256	31400	655	540	1170.0
1100	YEL-1100/50	–	10916	50	1590	7949	500	600	969.0
1100	YEL-1100/100	–	10916	100	1590	15896	550	600	1201.0
1100	YEL-1100/150	–	10916	150	1590	23845	600	600	1310.0
1100	YEL-1100/250	–	10916	250	1590	39741	700	600	1530.0

**!** Further piston strokes are quoted on request.



**A travel-speed chart is supplied on page 424-425.**

### High-tonnage cylinders model YEGA

Single-acting, gravity return capacity max. 140 - 1100 t

These inexpensive cylinders of series YEGA are used for all general lifting applications in any area of industry where heavy loads need to be lifted, lowered, levelled, positioned or supported.

Lifting and moving large machinery, steel construction, bridges or similar loads, supporting buildings and foundations.

For all heavy-duty jacking applications where a special safety factor is appropriate like lifting and lowering bridges, supporting buildings and foundations, jacking up heavy machines, steel sections, ship modules or similar loads.

#### Features

- Operating pressure max. 700 bar.
- Plunger in special piston guiding bands.
- Hard chromium-plated piston.
- Overflow hole ensures a definite piston end stop.
- Interchangeable hardened saddle.
- Oil port thread 3/8 NPT.
- Incl. female coupler half model CFY-1.
- All cylinders have lifting rings.

**The use of tilt saddles is recommended.**



### Tilt saddles for cylinders model AYL

Tilt saddles should be used with YEL and YEGA cylinders in cases where cylinders are operated on non-parallel surfaces.

The saddles minimize inner friction caused by eccentric loading of the cylinders. The upper part of the saddle can pivot up to 5° in all directions. Tilt saddles are fixed in the piston by means of an O-ring.

**Available for all cylinder series YEL, YEGA and YEHA up to 1100 t.**  
**Also available for cylinder series YS from 10 - 50 t.**

## Technical data model YEGA

Cylinder size t	Model	EAN-No. 4025092*	Capacity max. kN	Lift mm	Effective plunger area cm <sup>2</sup>	Oil volume max. cm <sup>3</sup>	Closed height mm	Cylinder outside diameter mm	Weight kg
140	YEGA-140/50	*163385	1380	50	201	1005	155	200	38
140	YEGA-140/100	*163194	1380	100	201	2010	205	200	51
140	YEGA-140/150	*163200	1380	150	201	3015	255	200	63
140	YEGA-140/200	*163217	1380	200	201	4020	305	200	75
140	YEGA-140/300	*163231	1380	300	201	6030	405	200	100
220	YEGA-220/50	*163248	2200	50	314	1570	170	250	64
220	YEGA-220/100	*163255	2200	100	314	3140	220	250	85
220	YEGA-220/150	*163262	2200	150	314	4710	270	250	104
220	YEGA-220/250	*163286	2200	250	314	7850	370	250	143
340	YEGA-340/50	*163309	3370	50	491	2453	210	310	123
340	YEGA-340/100	*163319	3370	100	491	4906	260	310	154
340	YEGA-340/150	*163323	3370	150	491	7360	310	310	184
340	YEGA-340/250	*163347	3370	250	491	12300	410	310	243
430	YEGA-430/50	*163484	4226	50	616	3079	215	340	125
430	YEGA-430/100	*163491	4226	100	616	6158	265	340	157
430	YEGA-430/150	*163507	4226	150	616	9236	315	340	190
430	YEGA-430/250	*163927	4226	250	616	15394	415	340	255
560	YEGA-560/50	–	5520	50	804	4019	240	390	223
560	YEGA-560/100	–	5520	100	804	8038	290	390	272
560	YEGA-560/150	–	5520	150	804	12058	340	390	319
560	YEGA-560/250	–	5520	250	804	20100	440	390	413
670	YEGA-670/50	–	6603	50	962	4811	265	430	298
670	YEGA-670/100	–	6603	100	962	9621	315	430	355
670	YEGA-670/150	–	6603	150	962	14432	365	430	412
670	YEGA-670/250	–	6603	250	962	24053	465	430	525
880	YEGA-880/50	–	8625	50	1257	6280	290	490	423
880	YEGA-880/100	–	8625	100	1257	12560	340	490	503
880	YEGA-880/150	–	8625	150	1257	18840	390	490	577
880	YEGA-880/250	–	8625	250	1257	31400	490	490	725
1100	YEGA-1100/50	*163569	10916	50	1590	7949	415	550	766
1100	YEGA-1100/100	*163576	10916	100	1590	15896	465	550	867
1100	YEGA-1100/150	–	10916	150	1590	23845	515	550	960
1100	YEGA-1100/250	*163743	10916	250	1590	39741	615	550	1147

**!** Further piston strokes are quoted on request.

## Technical data model AYL

Model	EAN-No. 4025092*	Suitable for cylinder groups	Weight kg
AYL-30	*156837	YEL-30...	0.4
AYL-50	*156844	YEL-50...	0.8
AYL-100	*156851	YEL-93...	2.0
AYL-150	*156868	YEL-140... and YEGA-140...	3.4
AYL-200	*156875	YEL-220... and YEGA-220...	5.8
AYL-340	–	YEL-340... and YEGA-340...	13.0
AYL-430	–	YEL-340... and YEGA-340...	19.5

## Dimensions model AYL

Model	AYL-30	AYL-50	AYL-100	AYL-150	AYL-200	AYL-340	AYL-430
A, mm	45	61	88	111	131	178	200
B, mm	36	39	47	52	57	67	79
C, mm	28	30	36	40	45	47	57

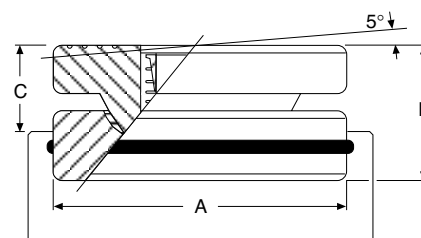



## Lifting claws, piston plates, base adaptors and extension tubes, load-spreading plates model AYS

### Lifting claws

In connection with the corresponding hydraulic cylinder a lifting claw represents a compact, lightweight and versatile lifting unit. The lifting claws are screwed onto the collar thread of cylinder series YS. Claws can be placed under loads with minimum clearance.

When operating lifting claws, the following aspects have to be considered:

The hydraulic cylinders need to be able to support themselves against the load. The max. force of the cylinder is reduced by 50%.

### Piston plates

Piston plates can be screwed into the piston thread of cylinder series YS. They reduce the surface pressure and prevent the pistons from sinking into the ground. Also when using a piston plate in connection with a lifting claw the cylinder must be supported against the load.

### Base adaptors and extension tubes

Extension tubes are mounted onto the bottom of cylinders series YS by means of the base adaptor and two hexagon socket screws (screws are included with the base adaptor). The use of extension tubes adds to the versatility of the standard cylinders.

### Load-spreading plates

These load-spreading plates are recommended when slim cylinders are used for lifting operations. They prevent the cylinders from falling over and sinking into the ground. Robust steel design with carrying handle.



AYS-101  
151  
231



Straightening of a container box by use of a hydraulic cylinder YS-10/100, extension tube AYS-106, base adaptor AYS-103 and electric power pump PY-04/2/5/2 M.



Lifting of a container by use of an hydraulic cylinder YS-23/160, lifting claw AYS-23 and piston plate AYS-232 powered by a two-stage hand pump HPS-2/2 with base frame.

## Technical data model AYS

Model	EAN-No. 4025092*	Description	Suitable for cylinder	Weight kg
AYS-10	*156721	Lifting claw, permissible capacity 5 t	YS-10/...	0.9
AYS-15	*156738	Lifting claw, permissible capacity 8 t	YS-15/...	1.3
AYS-23	*156745	Lifting claw, permissible capacity 12 t	YS-23/...	3.8
AYS-53	*157049	Base adaptor, 5 t	YS-5/...	0.5
AYS-54	*157056	Extension tube 125 mm, 5 t	YS-5/...	0.9
AYS-55	*157063	Extension tube 250 mm, 5 t	YS-5/...	1.5
AYS-56	*157070	Extension tube 500 mm, 5 t	YS-5/...	2.8
AYS-101	*157100	Load-spreading plate 10 t	YS-10/...	10.5
AYS-102	*156752	Piston plate, round	YS-10/...	1.5
AYS-103	*156783	Base adaptor, 10 t	YS-10/...	0.7
AYS-104	*156790	Extension tube 125 mm, 10 t	YS-10/...	1.2
AYS-105	*156806	Extension tube 250 mm, 10 t	YS-10/...	2.2
AYS-106	*156813	Extension tube 500 mm, 10 t	YS-10/...	3.9
AYS-107	*156820	Extension tube 750 mm, 10 t	YS-10/...	5.9
AYS-151	*157131	Load-spreading plate 15 t	YS-15/...	10.5
AYS-152	*156769	Piston plate, round	YS-15/...	1.8
AYS-153	*156929	Base adaptor, 15 t	YS-15/...	0.9
AYS-154	*156936	Extension tube 125 mm, 15 t	YS-15/...	1.6
AYS-155	*156943	Extension tube 250 mm, 15 t	YS-15/...	2.9
AYS-156	*156950	Extension tube 500 mm, 15 t	YS-15/...	4.9
AYS-157	*156967	Extension tube 750 mm, 15 t	YS-15/...	7.9
AYS-231	*157162	Load-spreading plate 23 t	YS-23/...	10.5
AYS-232	*156776	Piston plate, round	YS-23/...	2.2

## Dimensions model AYS

Model	AYS-10	AYS-15	AYS-23	AYS-53	AYS-54	AYS-55	AYS-56	AYS-101	AYS-102	AYS-103	AYS-104	AYS-105
A, mm	90	110	125	53	125	250	500	230	140	58	125	250
B, mm	90	110	125	50	-	-	-	120	12	60	-	-
C, mm	30	30	30	-	-	-	-	58	-	-	-	-
D, mm	29	34	40	-	-	-	-	-	-	-	-	-
E, mm	22	25	35	-	-	-	-	-	-	-	-	-
F, mm	M57x1.5	M67x1.5	M85x2	M42x1.5	M42x1.5	M42x1.5	M42x1.5	-	M27x2	M50x2	M50x2	M50x2

Model	AYS-106	AYS-107	AYS-151	AYS-152	AYS-153	AYS-154	AYS-155	AYS-156	AYS-157	AYS-231	AYS-232
A, mm	500	750	230	140	70	125	250	500	750	230	160
B, mm	-	-	120	12	73	-	-	-	-	120	15
C, mm	-	-	68	-	-	-	-	-	-	86	-
D, mm	-	-	-	-	-	-	-	-	-	-	-
E, mm	-	-	-	-	-	-	-	-	-	-	-
F, mm	M50x2	M50x2	-	M33x2	M60x2	M60x2	M60x2	M60x2	M60x2	-	M40x2

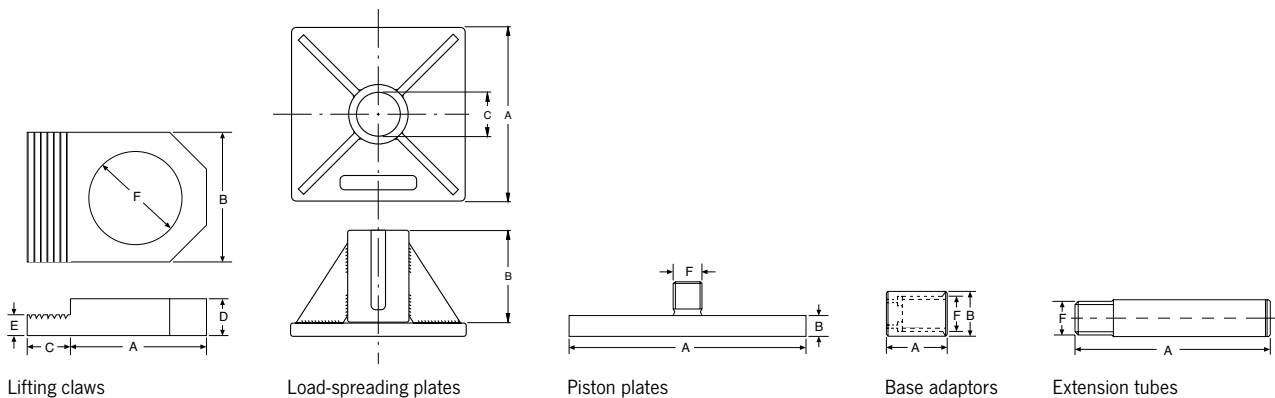





## Threaded flanges model AYP

In case hydraulic cylinders have to be inserted into fixtures, press frames or similar devices, these steel flanges can be very handy. Material: weldable steel.

### Technical data model AYP

Model	EAN-No. 4025092*	Suitable for cylinder	Weight kg
AYP-1010	*157407	YS-10/...	9.7
AYP-1510	*157414	YS-15/... and YH-10/...	12.6
AYP-2310	*157421	YS-23/... and YH-20/...	12.1
AYP-5010	*159531	YS-50/... and YH-50/...	19.6
AYP-10010	*159548	YS-100/... and YH-100/...	46.0
AYP-20010	*159555	YH-200/...	97.0

### Dimensions model AYP

Model	AYP-1010	AYP-1510	AYP-2310	AYP-5010	AYP-10010	AYP-20010
A, mm	M57 x 1.5	M67 x 1.5	M85 x 2	M125 x 2	M180 x 3	M250 x 4
B, mm	220	220	220	250	330	450
C, mm	200	200	200	250	330	450
D, mm	30	40	40	50	70	80
E, mm	120	120	120	225	300	400
F, mm	150	150	150	225	300	400
G, mm	M12	M12	M12	Ø 13.5	Ø 17.5	Ø 17.5
H, mm	M8	M8	M8	M8	M8	M8

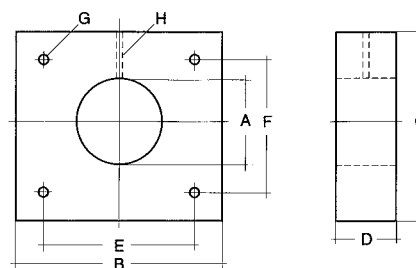

Model AYP

### Clevis eye mountings model AYH

Clevis eye mountings are screwed onto the piston and bottom of the hydraulic cylinder whenever mounting conditions require a pivoting of the cylinder.



#### Technical data model AYH

Model	EAN-No. 4025092*	Suitable for cylinder	Suitable for	Weight kg
AYH-5-1	*157179	YH-5/30, YH-5/80, YH-5/150	Cylinder base	0.3
AYH-5-2	*157186	YH-5/30, YH-5/80, YH-5/150	Piston	0.3
AYH-10-1	*157193	YH-10/30, YH-10/80, YH-10/150, YH-10/250	Cylinder base	0.6
AYH-10-2	*157209	YH-10/30, YH-10/80, YH-10/150, YH-10/250	Piston	0.6
AYH-20-1	*157216	YH-20/150, YH-20/250	Cylinder base	2.1
AYH-20-2	*157223	YH-20/150, YH-20/250	Piston	2.1

#### Dimensions model AYH

Model	AYH-5-1	AYH-5-2	AYH-10-1	AYH-10-2	AYH-20-1	AYH-20-2
A, mm	M27x2	M27x2	M36x2	M27x2	M45x2	M36x2
B, mm	-	-	-	40	-	70
C, mm	35	35	38	38	50	50
D, mm	35	35	42	42	65	65
E, mm	15	15	25	25	35	35
F, mm	16	16	20	20	30	30
G*, mm	M35x1.5	M35x1.5	M40x1.5	-	M70x2	-
H, mm	-	-	-	21	-	24
J, mm	18	18	21	-	23	-

\*G=retainer nut DIN 981

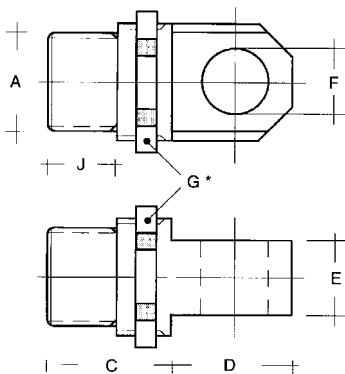

Model AYH-...-1 for cylinder base

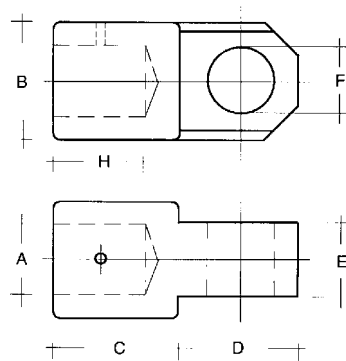

Model AYH-...-2 for piston

## Build-up and description of Yale hand pumps

Hand pumps are the most common power source within the area of "High-Pressure Hydraulic Tools". For this reason our hand pumps have been carefully designed and equipped with many details which make the pumps very versatile and handy in every-day applications.

### Relief valve/hand wheel

The fine-adjustment relief valve in connection with the large hand wheel allows millimeter increments when lifting and lowering even highest loads. The fact that sometimes hundreds of tons are controlled by this hand wheel underlines the importance of this feature.

### Sturdy "all-metal-design"

The robust pump head and the absence of any plastic parts result in a long service life and easy maintenance over many years. Plastic reservoirs filled with oil may present a fire risk in connection with welding or similar work!

### Carrying handle

A handy carrying handle on all our hand pumps facilitates transportation enormously.

### Pressure relief valves

All hand pumps are equipped with two pressure relief valves. They are easily adjustable from outside if pumps must be re-adjusted or a lower operating pressure should not be exceeded.

### Reservoir ventilation

All hand pumps are equipped with a reservoir ventilation plug. This ensures perfect suction of hydraulic oil and allows you to use the total oil capacity of the reservoir.

### Two-stage output

All hand pumps have two-stage design (except HPS-1/0,7). This allows an increased speed and efficient working during unloaded conditions of the hydraulic cylinder. The switch-over from the low pressure to the high pressure stage is done automatically.

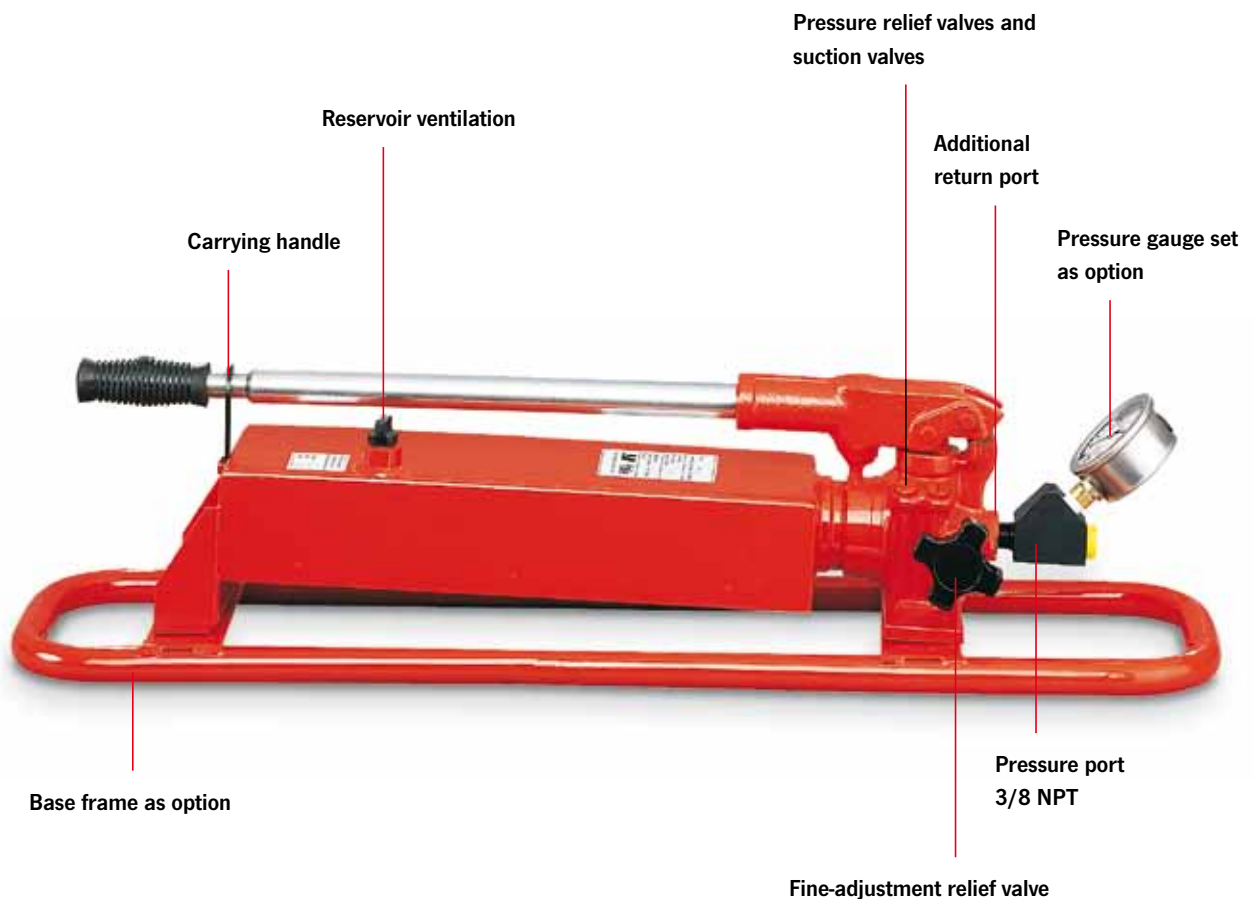

## Delivered ready to use

All hand pumps are supplied ready to use incl. hydraulic oil.

## Easy-maintenance-design

There is no need to disassemble the hand pumps in case of service work. All parts like suction and pressure valves, seals, packings etc. are accessible from the outside.

## All hand pumps have the same design

The same design (build-up) for all hand pumps with the exception of the reservoirs allows the interchangeability of all components. Therefore spare part stocks can be kept to an absolute minimum. Only one spare part kit is necessary to service all hand pumps.

## Excellent suction properties

Hand pumps suck and displace 100 % of their volume per stroke. This results both in a high efficiency as well as a rapid cylinder movement.

## Interchangeability

All hydraulic cylinders, hand pumps and other components are fully interchangeable and can be combined with all other 700 bar hydraulic lines. All components have the standard oil port and same coupler parts.

## Additional return oil port

All hand pumps are equipped with a return port to the reservoir. This detail is very advantageous as many hand pumps are integrated in more complex hydraulic circuits.

## Base frame

On request you can get base frames for the most common hand pumps. These base frames add to the stability and protection of the hand pumps, in particular when used in the field or on a construction site.

## Pressure gauge

Appropriate pressure gauges with the corresponding adaptors are shown.



Hand pump model: HPH...

With integrated pressure gauge GGY-631 and gauge adaptor set GA-704.

## Hand pumps for double-acting cylinders with relief valve and 4/2-way directional valve

Unlike conventional pumps, all hand pumps of the model HPH (with 4/2-way directional valve for double-acting cylinders) include a precision relief valve in addition to the directional control valve. Manual directional control valves switch over abruptly, thus causing undesired pressure surges in the system under load.

The additional relief valve in all HPH-hand pumps allows a precise lowering of the load without any pressure shocks. All components have the standard oil port and same coupler parts.

### Further advantage of this design:

The pressure gauge shows the pressure as pushing and as pulling force. The combination of a 4-way directional valve with a sensitive relief valve allows a controlled pressure relief without pressure shocks.

**!** A selection chart "cylinder/hand pumps" can be found on page 421-423.



### Hand pumps for single-acting cylinders model HPS

Hand pumps are easy to use and operate independently of any external energy source. They are designed for a maximum 700 bar system pressure and will allow each hydraulic cylinder to utilize its maximum capacity.

The two-stage system reduces pumping time.

Stage 1 allows rapid piston travel under no load or light load conditions. The pump automatically switches to stage 2 when the piston is loaded and a higher force is required from top. The hand pump is an all-steel construction designed for rough use and has a high-efficiency pumping action. The handle can be locked for easy carrying.

The large and easy-to-control return valve allows the operator to precisely control the return stroke. Other standard features include a large and easy-to-control hand wheel, air bleeding and oil filling plug, large support feet for stability, tilted tank to increase usable oil volume and ergonomic handle grip.

#### Features

- Operating pressure max. 700 bar.
- Two-stage operation with automatic switch-over (except HPS-1/0,7 A).
- Large reservoir volumes.
- With pressure relief valves, adjustable from the outside.
- Precision-adjustable relief valve (handwheel).
- Robust all-steel construction.
- HPH pumps are equipped with a 4-way control valve plus a precision-adjustable relief valve.
- Oil port thread 3/8 NPT.
- Incl. oil filling.
- Pressure gauges with corresponding adaptors are also available as accessories.

Hydraulic hoses are the connection between hand pump and hydraulic cylinders and need to be selected separately.

See page 397.

## Technical data model HPS

Model	EAN-No. 4025092*	Displacement	Reservoir volume cm <sup>3</sup>	Displacement 1 <sup>st</sup> stage cm <sup>3</sup>	Displacement 2 <sup>nd</sup> stage cm <sup>3</sup>	Weight kg
HPS-1/0,7 A	*159081	single-stage	700	–	2	7.0
HPS-2/0,3 A	*160148	two-stage	300	5	1	3.5
HPS-2/0,7 A	*159098	two-stage	700	11	2	7.0
HPS-2/2 A	*159104	two-stage	2000	11	2	10.0
HPS-2/4 A	*159111	two-stage	4000	11	2	13.0
HPS-2/6,5 A	*159128	two-stage	6500	11	2	21.0
HPS-2/10 A	*159135	two-stage	10000	11	2	27.0

## Dimensions model HPS

Model	HPS-1/0,7 A	HPS-2/0,3 A	HPS-2/0,7 A	HPS-2/2 A	HPS-2/4 A	HPS-2/6,5 A	HPS-2/10 A
A, mm	505	410	505	520	645	645	800
B, mm	85	100	85	70	65	65	65
C, mm	135	105	135	145	160	215	250
D, mm	150	125	150	150	150	180	190
E, mm	43	35	43	43	43	43	43
F, mm	52	35	52	52	52	52	52

Dimensions approx.

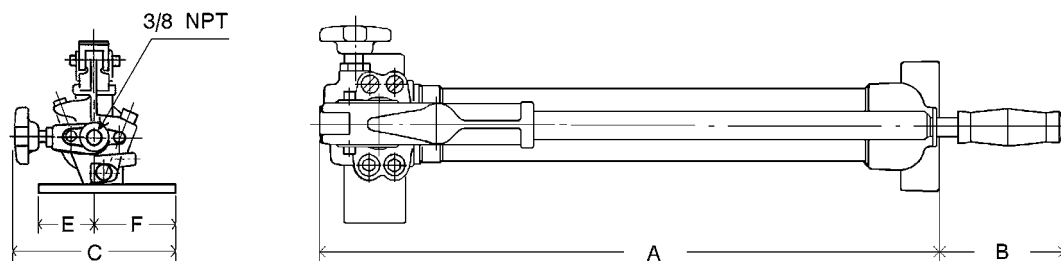



## Hand pumps for double-acting hydraulic cylinders model HPH

With 4-way valve and relief valve (hand wheel)

All hand pumps of type HPH are designed as double-acting cylinders. Basically, they do not differ from series HPS, but are equipped with a 4/3-way directional valve.

The precision-adjustable relief valve remains unaffected and permits a sensitive pressure relief. Pressure gauge and adaptor can be delivered as accessories.

### Technical data model HPH

Model	EAN-No. 4025092*	Displacement	Reservoir volume cm <sup>3</sup>	Displacement 1 <sup>st</sup> stage cm <sup>3</sup>	Displacement 2 <sup>nd</sup> stage cm <sup>3</sup>	Weight kg
HPH-2/0,7 A	*159159	two-stage	700	11	2	8
HPH-2/2 A	*159166	two-stage	2000	11	2	11
HPH-2/4 A	*159173	two-stage	4000	11	2	14
HPH-2/6,5 A	*159180	two-stage	6500	11	2	22
HPH-2/10 A	*159197	two-stage	10000	11	2	28

### Dimensions model HPH

Model	HPH-2/0,7 A	HPH-2/2 A	HPH-2/4 A	HPH-2/6,5 A	HPH-2/10 A
A, mm	590	595	715	715	880
B, mm	95	65	65	65	65
C, mm	160	160	160	200	160
D, mm	165	165	180	180	190
E, mm	55	55	55	55	55
F, mm	80	80	80	80	80
G, mm	85	85	85	85	85

Dimensions approx.

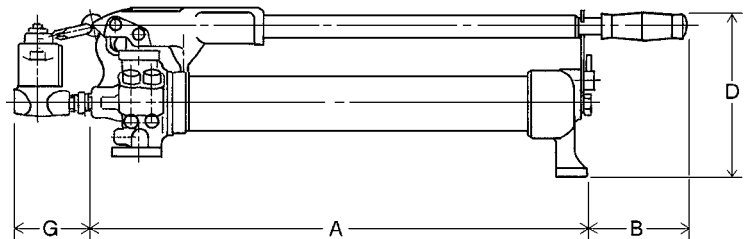
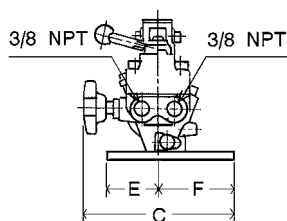



## Base frames for hand pumps model HPB

These base frames add to the stability of your hand pump, in particular when used in the field or on a construction site where hand pumps are frequently operated on uneven and soft ground.

At the same time, the hand pumps are protected from sand, humidity and possible damage.

The assembly of the base frames is very easy; just three holes have to be bored to mount the frame to the hand pump.



### Technical data model HPB

Model	EAN-No. 4025092*	Suitable for hand pump	Weight kg
HPB-2	*156684	HPS-1/0,7 A + HPS-2/0,7 A + HPS-2/2 A + HPH-2/0,7 A + HPH-2/2 A	1.3
HPB-4	*156691	HPS-2/4 A + HPH-2/4 A	1.8
HPB-6	*156707	HPS-2/6,5 A + HPH-2/6,5 A	1.9

### Dimensions model HPB

Model	HPB-2	HPB-4	HPB-6
A, mm	765	885	910
B, mm	190	190	190

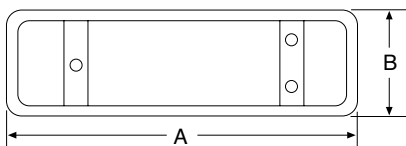



## Hand pump model HPS-1/1500A

This high-pressure pump is particularly designed to pressurize special components like hydraulic nuts, bolt-tensioning cylinders, hydraulic safety couplers or similar systems.

The pump is equipped with a pressure limiting valve which discharges to the atmosphere. The pump can be set to any pressure between 0 and 1500 bar. The pressure gauge is standard and allows permanent pressure control.

Due to a reservoir below, the pump can be operated in any position (hand-held design). During operation this pump must be held with two hands. The shown hydraulic hose is not part of the delivery package.



## Hand pumps model TWAZ

Operating pressure max. 2000 bar

These high-performance hand pumps allow a very rapid pressure build-up due to their two-stage design. Both pressure stages are equipped with a limiting valve which can easily be adjusted from outside.

High-pressure hand pumps are used for special applications like pressurizing hydraulic nuts and safety couplings, hydrostatic testing, bolt tensioners, high-pressure oil injection for bushing removal, pretensioning anchors, for test applications in laboratories and as a power source within test stands and propeller press systems.

### Accessories for hand pumps model TWAZ



Option:  
pressure gauge,  
model: GGY-2500.



Option:  
pressure gauge-adaptor,  
model GA-2000.



Option:  
adaptor, model: FY-201  
(M22 x 1.5 on G 1/4).



Option:  
hydraulic hoses,  
model: HH-2001-20,  
max. pressure: 2000 bar.

### Technical data model HPS-1/1500A and model TWAZ

Model	EAN-No. 4025092*	Pressure max. bar	Reservoir volume cm <sup>3</sup>	Displace- ment 1 <sup>st</sup> stage cm <sup>3</sup>	Displace- ment 2 <sup>nd</sup> stage cm <sup>3</sup>	Oil port	Pressure gauge	Pressure gauge model	Gauge adaptor	Pressure relief valve	Weight kg
HPS-1/1500A	*162876	1500	160	–	0.3	G 1/4	standard	GGY-639	–	yes	2.6
TWAZ-0,7	*159920	2000	700	8	0.6	M22 x 1.5	optional	GGY-2500	GA-2000	yes	7.0
TWAZ-1,3	*159937	2000	1300	13	1.0	M22 x 1.5	optional	GGY-2500	GA-2000	yes	9.0
TWAZ-2,3	*159951	2000	2300	31	1.6	M22 x 1.5	optional	GGY-2500	GA-2000	yes	16.0

## Foot pump model FPS

### Operating pressure 700 bar

Used to operate single-acting hydraulic cylinders, especially for repeated applications, such as checking of welding samples, pressing of connection components (crimping), actuating of clamping devices, as well as for all applications, where it is necessary to keep hands free.

The pump can be used everywhere, as it is independent of an external energy source and is easily portable. An extremely good stability guarantees a comfortable and safe operation up to the highest pressure. It is a “real” foot operated pump, as the return stroke of the connected hydraulic cylinder is released by foot control.

### Features

- Operating pressure max. 700 bar.
- Absolute stability due to large base plate.
- Minimized labour fatigue.
- Operating pressure adjustable. Valves accessible from the outside.
- Return stroke of cylinder also controlled by foot operation.
- Oil port 3/8 NPT.

### Options

- Pressure gauges and suitable adaptors.
- Hydraulic hoses



## Technical data model FPS

Model	EAN-No. 4025092*	Operating pressure bar	Displacement 1 <sup>st</sup> stage cm <sup>3</sup>	Displacement 2 <sup>nd</sup> stage cm <sup>3</sup>	Reservoir volume useable cm <sup>3</sup>	Weight kg
FPS-2/0,5 A	*160155	700	11	2	500	7



PY-04/2/5/2M

PY-04/2/5/4M

### Operation of the power pump

#### PY-04/2/5/2E:

By activating push-button number 1, the motor starts and the cylinder advances. In the neutral position the pressure is held. By activating push-button number 2, the solenoid valve is activated, the pressure decreases and the hydraulic cylinder retracts.

## Electric motor pumps model PY-04

Portable, operating pressure max. 700 bar

These light-weight but powerful two-stage pumps are particularly designed for maintenance and repair jobs. Depending on their type, they can either operate single-acting or double-acting hydraulic cylinders.

The ideal combination of manually operated valve and remote pendant control provides the operator with ample freedom of motion and ensures a safe "holding of the load".

The remote pendant control (1.5 m) is used to start the motor even under full load. The function for both manual valves is as follows: – advance – stop – return – With their light weight and convenient carrying handle, these pumps can be easily transported. Pumps are equipped with thermal overload protection and are supplied with hydraulic oil.

### Operation of the power pump

#### PY-04/2/5/2M:

The 2/2-way manual valve operates together with a pilot operated unloading valve, so that the two valve positions result in the following two control possibilities:

1. Cylinder holds pressure after motor stop.
2. Cylinder automatically retracts after motor stop.

### Technical data model PY-04

Model	EAN-No. 4025092*	Control valve	Operating pressure max. bar	No load stroke l/min up to 30 bar	Under load stroke l/min up to 700 bar	Useable reservoir volume	Connecting valve	Cable remote control m	Speed rpm	Protection standard	Weight, without oil, approx. kg
PY-04/2/5/2 M	*153263	2/2-way manual valve	700	4.0	0.23	5.0	0.37 kW - 230 V-1Ph	1.5	2800	IP 50	24
PY-04/2/5/4 M	*153294	4/3-way manual valve	700	4.0	0.23	5.0	0.37 kW - 230 V-1Ph	1.5	2800	IP 50	26
PY-04/2/5/2 E	*163392	2/2-way solenoid	700	4.0	0.23	5.0	0.37 kW - 230 V-1Ph	1.5	2800	IP 50	28

## Mini hydraulic pumps model PAY

### With compressed air driven motor 700 bar

These mini-pumps are driven by an air-powered motor and can be connected to any supply source of compressed air. These compact low-cost pumps can operate all single-acting or double-acting hydraulic cylinders up to a max. operating pressure of 700 bar.

Due to large reservoirs, large cylinders or multiple cylinders can be operated. The use of an inline air filter-lubricator is recommended.

The hydraulic pressure can be infinitely adjusted on the regulator of the air-lubricator unit. The air-driven motor guarantees 100% explosion protection.

Pumps for double-acting hydraulic cylinders are equipped with an additional 4-way control valve type VHH-4/3.

The connected hydraulic cylinder is controlled – advance – stop – return – by the universal pedal, which can be either hand or foot-operated.



### Control of cylinder motion

- Pedal in neutral position – motor stands still, cylinder stands, pressure is held.
- Pedal depressed – motor starts, cylinder advances, pressure is built-up.
- Pedal pushed forward – motor stands still, pressure is released, cylinder retracts.

### Technical data model PAY

Model	EAN-No. 4025092*	For cylinders	Reservoir volume	Oil pressure max. bar	Oil-displacement l/min	Required air pressure bar	Air consumption l/min	Oil port	Air port	Weight kg
PAY-6	*153270	single-acting	1.5	700	0.85 up to 0.08	7	560	3/8 NPT	1/4 NPT	6.3
PAY-6-5	*160735	single-acting	5.0	700	0.85 up to 0.08	7	560	3/8 NPT	1/4 NPT	12.0
PAY-64	*153614	double-acting	1.5	700	0.85 up to 0.08	7	560	3/8 NPT	1/4 NPT	7.5
PAY-64-5	*160940	double-acting	5.0	700	0.85 up to 0.08	7	560	3/8 NPT	1/4 NPT	13.0

**!** For information on training please see page 4-5.



PY-11/3/20/4M

## Electric hydraulic power packs model PYE and model PY

### Single-stage and two-stage

Power packs are easy to operate as they are fully assembled and easy to control.

The use of power packs is always recommended when jobs have to be done in a time-saving and efficient way, when repeating jobs have to be finished off, quick cylinder cycles have to be achieved or if large oil volumes in connection with high-tonnage cylinders have to be transmitted.

### Two-stage output

The standard power packs are equipped with two-stage pumps, which means that a low pressure stage fills the connected hydraulic cylinder quickly up to a pressure of 80 bar. The high pressure stage is activated automatically from 80 bar up to 700 bar, while the low pressure stage is discharged back to the reservoir. This economic solution avoids heating-up, saves energy and keeps the power packs compact.

### Single-stage output model PYE

The hydraulic packs have single-stage pumps. These packs deliver between 0 and 700 bar with the same volume (high-pressure stage).

### Control/Operation

The motion control of the connected hydraulic cylinder is done by operating the directional valve.

### Do you have a single-acting or a double-acting hydraulic cylinder?

The directional control valve has to correspond to the a.m. functional principle of the hydraulic cylinder to be operated. Depending on these principles the power packs are equipped with a:

- 3/3-way valve to operate single-acting hydraulic cylinders (connection with one hydraulic hose)
- 4/3-way valve to operate double-acting hydraulic cylinders (connection with two hydraulic hoses)

The directional control valves are available either as manual or solenoid operated valves.

### Operation of the directional valves

Depending on the way of operation, there are manual or solenoid operated valves. Manual valves are controlled by shifting the operating lever and represent the economic way of control.

These valves have 3 lever positions:  
– advance – hold – retract –



PY-07/3/10/3E

## Solenoid valves

Solenoid valves have the advantage that they are controlled by a pendant remote control box which makes the operator independent from the power pack, making it easier for him to monitor the job.

The solenoid valves are controlled by two push-buttons – advance – hold – retract – In neutral position – hold – the valves rest in pressureless circuit. Pressure and force of the connected cylinder are held without pressure drop. The complete electrical set-up (with 24V control) belongs to the scope of delivery. Solenoid valves allow a very ergonomic operation and offer a quick and precise switching (millimeterwise) of the connected hydraulic cylinder.

## Pressureless circuit

In neutral position all directional valves rest in pressureless circuit which means that the oil flow coming from the rotating pump is guided back to the reservoir without creating any pressure build-up.

## Special solenoid valve configurations

Some applications require a special valve configuration, e.g. the independent control of several hydraulic cylinders from a single power pack. In such cases the complete valve build-up and electrical control is designed according to customer's requirements.

## Pressure-Guard power packs

By using an electro-hydraulic pressure switch and a special electric control, power packs automatically control their pre-adjusted pressure. In applications where the pressure (load) should be applied over a very long period, the connected power pack is switched on and off automatically and replaces the pre-set pressure in case a pressure drop has occurred.

## Trolleys

For all power packs we offer a cart-frame for flexible movement from job to job. Cart-frames are equipped with 2 fixed and 2 swivel castors.

## Oil cooler

For certain applications, especially when power packs are continuously operated and the oil temperature could exceed 60° C, the use of an oil cooler is recommended.

## Hydraulic oil

All power packs are designed for an operation with standard hydraulic oil (specification ISO VG 32). For certain operating conditions the viscosity class of the hydraulic fluid can be varied. All power packs are supplied including oil.

## Features

- Robust packs, also capable for continuous applications.
- Suitable for all jobs in workshops and on construction sites where hydraulic force is required; supplied ready to use.
- On-off motor switch and 3 m motor connecting cable.
- With carrying handles, oil level gauge, oil filler/resevoir ventilation plug.
- Incl. pressure gauge GGY-631.
- Two-stage displacement, which means a rapid advance without load, as well as an automatic switch into the 2. phase by a congruous load.
- Low noise level due to standard motors with 1450 rpm.
- Further motor voltage and oil resevoirs on request.
- With manual or solenoid operated directional valves.
- Solenoid valves with 3 m remote control box (with 2 push-buttons) and pressure set valve as standard. Adjustable from 0-700 bar.
- 24V - low voltage control includes a sturdy metal electric control box and ready to use set up.





# Hydraulic Jacks & Tools Electric hydraulic power packs

## Two-stage electric hydraulic power packs, 700 bar

Model	Reservoir size				Control valve (directional valve)				Motor power kw	Displacement, two-stage	
	10 l	20 l	30 l	50 l	manual valve		solenoid valve			approx. l/min 0 - 80 bar	approx. l/min 80 - 700 bar
					3/3-way	4/3-way	3/3-way	4/3-way			
PY-07/3/10/3 M	•	–	–	–	•	–	–	–	0.75	6.0	0.6
PY-07/3/10/4 M	•	–	–	–	–	•	–	–	0.75	6.0	0.6
PY-07/3/20/3 M	–	•	–	–	•	–	–	–	0.75	6.0	0.6
PY-07/3/20/4 M	–	•	–	–	–	•	–	–	0.75	6.0	0.6
PY-07/3/20/3 E	–	•	–	–	–	–	•	–	0.75	6.0	0.6
PY-07/3/20/4 E	–	•	–	–	–	–	–	•	0.75	6.0	0.6
PY-11/3/20/3 M	–	•	–	–	•	–	–	–	1.1	8.5	1.0
PY-11/3/20/4 M	–	•	–	–	–	•	–	–	1.1	8.5	1.0
PY-11/3/30/3 M	–	–	•	–	•	–	–	–	1.1	8.5	1.0
PY-11/3/30/4 M	–	–	•	–	–	•	–	–	1.1	8.5	1.0
PY-11/3/20/3 E	–	•	–	–	–	–	•	–	1.1	8.5	1.0
PY-11/3/20/4 E	–	•	–	–	–	–	–	•	1.1	8.5	1.0
PY-11/3/30/3 E	–	–	•	–	–	–	•	–	1.1	8.5	1.0
PY-11/3/30/4 E	–	–	•	–	–	–	–	•	1.1	8.5	1.0
PY-22/3/30/3 M	–	–	•	–	•	–	–	–	2.2	18.0	2.1
PY-22/3/30/4 M	–	–	•	–	–	•	–	–	2.2	18.0	2.1
PY-22/3/50/3 M	–	–	–	•	–	–	–	–	2.2	18.0	2.1
PY-22/3/50/4 M	–	–	–	•	–	•	–	–	2.2	18.0	2.1
PY-22/3/30/3 E	–	–	•	–	–	–	•	–	2.2	18.0	2.1
PY-22/3/30/4 E	–	–	•	–	–	–	–	•	2.2	18.0	2.1
PY-22/3/50/3 E	–	–	–	•	–	–	•	–	2.2	18.0	2.1
PY-22/3/50/4 E	–	–	–	•	–	–	–	•	2.2	18.0	2.1

<b>Code explanation</b>											
Directional valve : 3 = for single-acting, 4 = for double-acting cylinder, M = manual valve, E = solenoid valve											
Reservoir size : in liters (other reservoir sizes on request)											
Motor voltage : 3 = 380-420 V, 3-phase (Euro-voltage), 2 = 230 V, 1-phase, (other voltages on request)											
Hoist motor : 07 = 0.75 kW, 11 = 1.1 kW, 22 = 2.2 kW, 30 = 3 kW, 55 = 5.5 kW, 75 = 7.5 kW, 110 = 11 kW											
Type of motor : PY = electric motor, PAY = air motor, PGY = petrol driven motor (4 cycle)											

## Single-stage electric hydraulic power packs, 700 bar

Model	Reservoir size				Control valve (directional valve)				Motor power kw	Displacement l/min 0 - 700 bar
	10 l	20 l	30 l	50 l	manual valve		solenoid valve			
					3/3-way	4/3-way	3/3-way	4/3-way		
PYE-03/3/10/3 M	•	–	–	–					0.35	0.3
PYE-03/3/10/4 M	•	–	–	–					0.35	0.3
PYE-07/3/10/3 M	•	–	–	–					0.75	0.6
PYE-07/3/10/4 M	•	–	–	–					0.75	0.6
PYE-07/3/20/4 M	–	•	–	–					0.5	0.6
PYE-11/3/20/3 M	–	•	–	–					1.1	1.0
PYE-11/3/20/4 M	–	•	–	–					1.1	1.0
PYE-11/3/30/4 M	–	–	•	–					1.1	1.0
PYE-22/3/20/3 M	–	•	–	–					2.2	2.1
PYE-22/3/20/4 M	–	•	–	–					2.2	2.1
PYE-22/3/30/4 M	–	–	•	–					2.2	2.1
PYE-22/3/50/4 M	–	–	–	•					2.2	2.1

All  
valve and reservoir combinations  
available.

## High-performance electric hydraulic power packs, 700 bar, single-stage

Model	Reservoir size			Control valve (directional valve)				Motor power kw	Displacement l/min 0 - 700 bar
	50 l	100 l	150 l	manual valve		solenoid valve			
				3/3-way	4/3-way	3/3-way	4/3-way		
PYE-40/3/50/4 M	•	–	–					4.0	2.7
PYE-55/3/70/4 M	•	–	–					5.5	4.0
PYE-75/3/100/4 M	–	•	–					7.5	6.0
PYE-110/3/150/4 M	–	–	•					11.0	8.0
PYE-180/3/150/4 M	–	–	•					18.0	12.0

All  
valve and reservoir combinations  
available.

### Hydraulic power pack with protection cage

This power pack is specially designed for general lifting applications in construction areas. Equipped with an optimized valve configuration, including 4-way manual directional valve VHP-4/3-1, safety-check valve VSM-21, pressure relief valve VPR-3 and 2 pressure gauges for permanent load control.



### Hydraulic power pack with 4-way manifold MY-44-GYA

The most economic way for a pressure-independent and individual control of 4 single-acting hydraulic cylinders. The additionally mounted safety-check valve VSM-21 avoids uncontrolled pressure drops, and the built-in throttle valve allows a precise (millimeterwise) lowering even of the highest loads. Four pressure gauges allow a permanent reading of the individual loads. On request, the power packs can be equipped with a handy cart-frame to make the operation flexible. This type of power pack can be supplied in all sizes of the PY and PYE series.



### Hydraulic power pack with 4-times solenoid valve

The quadruple solenoid valve block ensures a pressure-independent and individual control of 4 double-acting hydraulic cylinders. Solenoid valves offer several well-known advantages such as: ergonomic and safe control by pendant remote control, exact load hold, precise and quick switch characteristics and many more.



### Double-hydraulic power pack

In order to realise very high oil flows, two independent pump systems can be combined in one large reservoir. A gear pump ensures an extremely high oil flow up to 250 bar while the high-pressure stage is generated by a high-performance radial piston pump. Each pump is equipped with its own solenoid control valve so that the individual oil flows can be generated or discharged on request.





PMF-15/3/40/4 x 3 M

**All extra loads can be meter-read permanently.**

### Multiple-flow hydraulic power packs model PMF

Multiple-flow hydraulic pumps can advance 4 cylinders with the same speed at the same time by injecting equal amounts of hydraulic oil into each individual cylinder. This principle allows a synchronized lifting of machines or similar loads from a central point. Even under different loading conditions the cylinders advance in synchronisation.

Levelling of a lopsided load is easily possible by an individual control of each single cylinder. The lifting phase is initiated by a push-button remote control box and can be interrupted and continued at any time.

Lowering of the load is done by operating the directional valve in connection with the throttle valve individually for each circuit. The multiple-flow pumps can drive all kinds of hydraulic cylinders, machine jacks or stage lifts.

#### Features

- 4-point synchronized lift due to 4 equal, independent and individual oil flows.
- 4 manually operated directional valves, or 4 solenoid directional valves allow an individual or joint control of all 4 connected cylinders (easy levelling of loads).
- Safe load hold due to check valve in each circuit.
- One-man central operation.
- Motor on-off switch by means of a pendant remote control box in connection with manual valves.
- A complete remote control box to operate the solenoid valves.

#### Options

- All pump packs are also available with 4/3 direction-valves (for controlling the double-acting hydraulic cylinders).
- All power packs can be supplied with a protection frame suitable for on-site operation. Also cart-frames with 2 fixed and 2 swivel castors are available on request.

#### Scope of delivery

For each of the four circuits the ready-to-use supply includes: glycerine-damped pressure gauge, 3-way control valve, safety-check valve, a female coupler-half as connecting port. Furthermore: hydraulic oil, carrying handles, motor on-off switch, motor connecting cable, pendant remote control, electro-box with transformer and motor relays, oil level gauge and oil-filler/ventilation plug. All multiple-flow power packs are also available with 4-way directional valves in order to operate double-acting hydraulic cylinders.

### 4-multiple-flow power packs with solenoid directional valves model PMF

4-multiple-flow power packs with solenoid directional valves to advance 4 hydraulic cylinders independently and in a synchronized way by means of solenoid valves with a pendant remote control box.

The solenoid valves in connection with safety-throttle valves allow a precise control of all connected hydraulic cylinders.



PMF-15/3/40/4 x 4 E

#### Technical data model PMF

Model	EAN-No. 4025092*	Operating pressure bar	Displacement l/min	Manual valve	Solenoid valve	Motor remote control	Reservoir size l	E-motor
PMF-07/3/20/2x3 M	*163521	2x700	2x0.3	•	–	•	20	0.75 kW-400V-3-phase
PMF-07/3/20/2x3 E	–	2x700	2x0.3	–	•	–	20	0.75 kW-400V-3-phase
PMF-15/3/20/2x3 M	–	2x700	2x0.6	•	–	•	20	1.5 kW-400 V-3-phase
PMF-15/3/20/2x3 E	–	2x700	2x0.6	–	•	–	20	1.5 kW-400 V-3-phase
PMF-15/3/40/4x3 M	*157827	4x700	4x0.3	•	–	•	40	1.5 kW-400 V-3-phase
PMF-15/3/40/4x3 E	*160681	4x700	4x0.3	–	•	–	40	1.5 kW-400 V-3-phase
PMF-30/3/40/4x3 M	*160957	4x700	4x0.6	•	–	•	40	3.0 kW-400 V-3-phase
PMF-30/3/40/4x3 E	*160902	4x700	4x0.6	–	•	–	40	3.0 kW-400 V-3-phase
PMF-55/3/100/4x3 M	–	4x700	4x1.0	•	–	•	100	5.5 kW-400 V-3-phase
PMF-55/3/100/4x3 E	–	4x700	4x1.0	–	•	–	100	5.5 kW-400 V-3-phase
PMF-110/3/100/4x3 M	*163972	4x700	4x2.1	•	–	•	100	11.0 kW-400V-3-phase
PMF-110/3/100/4x3 E	*162128	4x700	4x2.1	–	•	–	100	11.0 kW-400V-3-phase

**All multiple-flow power packs are also available with 4-way directional valves in order to operate double-acting hydraulic cylinders model PMF.**



VHP-4/3-1  
with  
VSM-21

VHP-4/3-1

VHP-4/3-2

VHP-3/3-1

VHH-4/3

In addition, all valves are equipped with a second pressure oil port P at the back of the valve base. This port can easily be used to connect a pressure gauge and a pressure relief valve (e.g. VPR-1). The oil port T shall always be connected to the reservoir without any back pressure.

## Directional valves, 700 bar model VHP and model VHH

### Manually operated

These directional valves control the oil flow in combination with hydraulic power packs (YHH-4/3 with hand pumps).

All valves have 3 lever positions to control movement of the connected hydraulic cylinder:

1. left: cylinder advance.
2. middle: cylinder neutral (pressureless circuit).
3. right: cylinder retracts.

In the middle position (hold) the piston of the cylinder stops and the oil flow is guided in a circuit back to the reservoir (P to T). The valves can be flanged directly onto power packs but can also be connected by using hydraulic piping.

### Technical data model VHP and model VHH

Model	EAN-No. 4025092*	Pressure max. l/min	Size	Oil ports	Hydraulic symbol	Applications
VHP-3/3-1	*155175	8 - 16	1	3/8 NPT		3/3-way valve with "open centre" in middle position (pressureless circuit) to control single-acting hydraulic cylinders, standard valve for smaller power packs, size 1.
VHP-3/3-2	*154857	20 - 40	2	3/8 NPT		3/3-way valve with "open centre" in middle position (pressureless circuit) to control single-acting hydraulic cylinders, standard valve for larger power packs, size 2.
VHP-3/3-1 CC	*155182	8 - 16	1	3/8 NPT		3/3-way valve with "closed centre" in middle position to control single-acting hydraulic cylinders, only for specific multiple valve configuration, size 1.
VHP-3/3-2 CC	*154932	20 - 40	2	3/8 NPT		3/3-way valve with "closed centre" in middle position to control single-acting hydraulic cylinders, only for a multitude of valve operations, size 2.
VHP-4/3-1	*155199	8 - 16	1	3/8 NPT		4/3-way valve with "open centre" in middle position (pressureless circuit) to control double-acting hydraulic cylinders, standard valve for smaller power packs, size 1.
VHP-4/3-2	*154864	20 - 40	2	3/8 NPT		4/3-way valve with "open centre" in middle position (pressureless circuit) to control double-acting hydraulic cylinders, standard valve for larger power packs, size 2.
VHP-4/3-1 CC	*154932	8 - 16	1	3/8 NPT		4/3-way valve with "closed centre" in middle position to control double-acting hydraulic cylinders, only for specific multiple valve configuration, size 1.
VHP-4/3-2 CC	*154956	20 - 40	2	3/8 NPT		4/3-way valve with "closed centre" in middle position to control double-acting hydraulic cylinders, only for specific multiple valve configuration, size 2.
VHH-4/3	*154840	2 - 3	small special design	1/4 NPT		4/3-way valve with "open centre" in middle position (pressureless circuit) to control double-acting hydraulic cylinders. Special design to be mounted directly to all HPS hand pumps (with connecting set FY-703). Also suitable for small hydraulic power packs.

## Solenoid directional valves model VEP

### 700 bar incl. pressure set valve

Solenoid operated valves are used to control the connected hydraulic cylinder by means of a pendant remote control or further electrical controls like pressure switches or limit switches.

### Control principle

All solenoid valves have 3 positions:

– **advance** – **stop** – **retract** –

In neutral position (stop) the valves switch to “pressureless circuit” so that the oil flow is guided back to the reservoir while the connected cylinder is safely held under pressure.

Normally, solenoid valves are mounted directly onto power packs but can also be connected by using hydraulic piping.

### Design

Long-life, direct-control ball seal valves with leak-free “load hold function” in neutral position.

The solenoids guarantee a very quick reaction of the valves so that cylinders can be controlled millimeterwise.

The valves are suitable for continuous operation (100% on/off duration).

### Modular design

The modular principle allows special valve configurations e.g. control of multiple cylinder systems or specific control sequences.

### Pressure adjustment

All solenoid valves are equipped with a precision-adjustable pressure set valve which allows the system pressure (force of cylinder) to be limited to any value from 0 to 700 bar.



VEP-3/3-1

VEP-4/3-1

### Pressure gauge

A glycerine-damped pressure gauge GGY-631 is standard with solenoid valves, 0-1000 bar, Ø 63 mm.

### Mounting flange

The valve flanges are designed in a way that valves (with pressure connector) can easily be mounted onto power packs.

### Options

The connector model FY-905 is to be ordered separately.

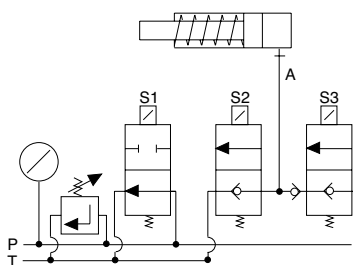

VEP-3/3-1 and VEP-3/3-2 for single-acting cylinders

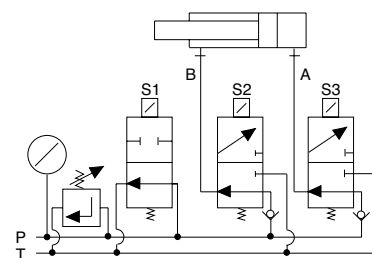

VEP-4/3-1 and VEP-4/3-2 for double-acting cylinders

**!** If oil ports A and B should have 3/8 NPT the adaptor model FY-30 is to be ordered separately.

## Technical data model VEP

Model	EAN-No. 4025092*	Control	For cylinders	Operating pressure max. bar	Size	Oil flow max. l/min	Control voltage	Oil ports P T	Pressure relief valve	Weight kg
VEP-3/3-1	*154994	3/3-way	single-acting	700	1	12	24 V =	3/8 NPT	yes	4.1
VEP-3/3-2	*155007	3/3-way	single-acting	700	2	25	24 V =	3/8 NPT	yes	7.9
VEP-4/3-1	*154987	4/3-way	double-acting	700	1	12	24 V =	3/8 NPT	yes	4.1
VEP-4/3-2	*155014	4/3-way	double-acting	700	2	25	24 V =	3/8 NPT	yes	7.9





### Selection advice

If the valve is to be screwed directly into a hydraulic cylinder, please order model VSM-11.

If the valve is to be combined with the directional valve of a power pack, please order model VSM-21. (see picture on page 224).

## Safety-check valves model VSM

### 700 bar

These safety-check valves are used for those applications where pressure drops must be avoided (e.g. holding of a lifted load). Depending on the location in a hydraulic circuit, these valves can have different functions.

The model VSM-11 can be directly screwed into the oil port of a hydraulic cylinder and works at this location as a "hose break fuse". The design of the VSM-21 is suitable for a combination with VHP directional valves.

At this location the VSM-21 ensures that the pressure is held precisely and that pressure drops caused by operating the directional valve are avoided.

### Operation

After closing the relief valve (hand wheel) the cylinder can be advanced via the by-pass. In direction to the cylinder the valves always have free flow. The built-in check valve ensures that a pressurized cylinder (e.g. a lifted load) is held precisely in stop position.

A smooth lowering speed can be adjusted by opening the throttle valve (hand wheel) in order to relieve the pressure.

A safety pressure valve protects the cylinder from being overloaded by external loading.

### Technical data model VSM

Model	EAN-No. 4025092*	Operating pressure max. bar	Control	Oil-port cylinder side A	Oil-port pump side B	Width mm	Weight kg
VSM-11	*157797	700	Check valve	3/8-18 NPT outer	3/8-18 NPT inner	6	0.9
VSM-21	*158442	700	Check valve	3/8-18 NPT inner	3/8-18 NPT outer	6	1.0

### Dimensions model VSM

Model	VSM-11	VSM-21
Length, mm	75	75
Width, mm	25	25
Height, mm	100	100

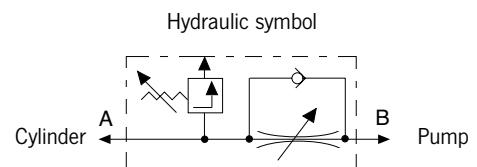



## Throttle-/Shut-off valves model VHM

700 bar

These valves are used to shut-off hydraulic lines especially in multiple cylinder systems. The needle valve VHM-1 also allows to throttle an oil flow especially in connection with lifting applications.



VHM-2



VHM-1

### Technical data model VHM

Model	EAN-No. 4025092*	Operating pressure max. bar	Control	Oil ports both ends	Width mm	Weight kg
VHM-1	*154819	700	Needle	3/8-NPT inner	6	0.4
VHM-2	*154963	700	Ball	3/8-NPT inner	6	0.9

### Dimensions model VHM

Model	VHM-1	VHM-2
Length, mm	75	75
Width, mm	28	45
Height, mm	100	75

Hydraulic symbol

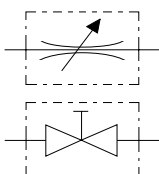

## Pressure switch model VPS

Adjustable between 100 - 800 bar

As soon as the pressure has reached the set value, a micro-switch (altering contact) is activated.

This signal can be used:

- For automatic pressure limiting.
- To report a certain pressure value.
- As an automatic motor on/off switch with pressure guard power packs.



### Technical data model VPS

Model	EAN-No. 4025092*	Control range bar	Electric data	Oil ports	Difference of switch point bar	Repeat accuracy bar	Weight kg
VPS-1	*155090	100 - 800	5 A/250 V	3/8 NPT	25 - 70	10	0.5

### Dimensions model VPS

Model	VPS-1
Height x width, mm	130x85

Hydraulic symbol

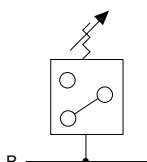

As soon as the pressure has reached the set value, a micro-switch (alternating contact) is activated. Should the pressure drop, the micro-switch starts the pump again in order to rebuild the pressure.



## Pressure relief valves model VPR

0 - 700 bar

Pressure relief valves are used if the system pressure (force of the connected hydraulic cylinder) should not exceed a certain value. These precision valves can be easily adjusted and are characterized by precise repetition. The question of a pressure relief valve only depends on the displacement of the high pressure stage of the power pack.

After achieving the set pressure value, the excessive oil is guided back to the reservoir (pressureless).

### Technical data model VPR

Model	EAN-No. 4025092*	Control range bar	Oil ports P	Oil ports T	Oil flow max. l/min	Weight kg
VPR-1	*155212	0-700	G3/8	G 1/4	10	0.8
VPR-3	*154888	0-700	3/8-NPT	1/4-NPT	5	1.2

### Dimensions model VPR

Model	VPR-1	VPR-3
Length, mm	120	145
Ø, mm	40	40

Hydraulic symbol

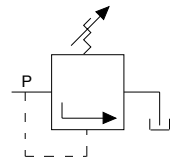

## Manifolds model MY

700 bar

Manifolds are used when several hydraulic cylinders have to be connected to one hydraulic pump. All manifolds are equipped with 3/8 NPT inner oil ports, so that fittings, hydraulic hoses and couplers can easily be attached. To connect a manifold directly to a hand pump a FY-1 double nipple is recommended.

Each manifold is supplied with three steel blind plugs in case not all the oil ports are required.



### Technical data model MY

Model	EAN-No. 4025092*	Oil ports	Weight kg
MY-1	*154789	6x3/8-NPT inner	0.5
MY-2	*154895	4x3/8-NPT inner	0.6
MY-4	*154833	7x3/8-NPT inner	1.4

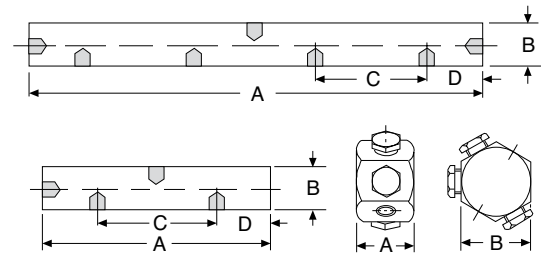

### Dimensions model MY

Model	MY-1	MY-2	MY-4
A, mm	40	150	330
B, mm	50	40	40
C, mm	-	90	90
D, mm	-	30	30



## Manifolds model MY

**With shut-off valve, 700 bar**

Manifolds with shut-off valves are used when different pressures must be maintained in each hydraulic line and therefore allow the lifting of unequal loads. The manifolds are fully assembled and can be screwed directly to a hand pump or power pack. Depending on the way of assembly a short hose HHC-10 and a coupler half CFY-1 can be helpful.

Manifolds models MY ... GYA are equipped with the corresponding number of shut-off valves plus pressure gauge sets (GYA-63) which allow a permanent reading of each individual load.

### Technical data model MY

Model	EAN-No. 4025092*	Version	Weight kg
MY-22	*155045	Manifold with 2 shut-off valves	1.8
MY-44	*155052	Manifold with 4 shut-off valves	3.7
MY-66	*159517	Manifold with 6 shut-off valves	5.5
MY-22-GYA	*159210	Manifold with 2 shut-off valves and 2 pressure gauges	2.8
MY-44-GYA	*159227	Manifold with 4 shut-off valves and 4 pressure gauges	5.7
MY-66-GYA	*159524	Manifold with 6 shut-off valves and 6 pressure gauges	8.5

Assembly examples:



Hand pump  
HPS - 2/2 with MY - 44



Electric hydraulic pump  
PY - 07/3/20/3 M with VSM - 21 and MY - 44

## Transportation box model HPK-10

For hand pumps, hydraulic cylinders and accessories

For easy transportation and protection of your valuable tools. Large enough to take a hand pump with pressure gauge and hydraulic hose plus several hydraulic cylinders.

The sturdy sheet metal box is equipped with a solid handle and two clasps.

**Model HPK-10**

Dimensions (LxWxH): 800x300x170 mm,  
weight: approx. 7.8 kg.



## Hydraulic oil model HFY

For all hand pumps and power packs

The high quality of the Yale hydraulic oil guarantees a long service life for your equipment.

The high grade HLP oil has the following features:

### Features

- Class of viscosity ISO VG 32.
- High lubrication index.
- High pressure resistance
- Favourable temperature/viscosity index.
- Protection against corrosion and cavitation.
- Minimizes the formation of foam and sludge.
- Good derivation of temperature.
- No aging problems
- Good compatibility with all sealing materials.
- Fulfills all requirements of DIN 51524 part 2.



### Technical data model HFY

Model	EAN-No. 4025092*	Content l
HFY-1	*156622	1
HFY-5	*156639	5
HFY-10	*159562	10
HFY-20	*159579	20



## Pressure gauges model GGY

The use of pressure gauges is recommended when the operating pressure (the force of the connected cylinder) should be monitored. Yale pressure gauges are equipped with a stainless steel housing and an acrylic plastic face cover plate.

To absorb pressure shocks gauges are glycerine-filled, thus contributing to a long service life. Also, when fitted to a motor pump, the pointer will stay jitterfree.

For the calculation of applied cylinder forces corresponding converting charts (pressure vs. force) can be supplied for all Yale hydraulic cylinders free of charge.

### Technical data model GGY

Model	EAN-No. 4025092*	Pressure range bar	Scale diameter mm	Glycerine- damped	Oil port DIN 16288	Spanner size	Accuracy class %
GGY-631	*154796	0 - 1000	63	yes	G 1/4	14	1.6
GGY-632	*155120	0 - 1000	63	yes	1/4 NPT	14	1.6
GGY-633	*155274	0 - 160	63	yes	G 1/4	14	1.6
GGY-634	*155281	0 - 250	63	yes	G 1/4	14	1.6
GGY-635	*155298	0 - 400	63	yes	G 1/4	14	1.6
GGY-636	*155304	0 - 600	63	yes	G 1/4	14	1.6
GGY-1001	*154802	0 - 1000	100	yes	G 1/2	22	1.0
GGY-1001 SZ*	*155168	0 - 1000	100	yes	G 1/2	22	1.0
GGY-1004	*155151	0 - 700	100	yes	G 1/2	22	1.0
GGY-1005	*159203	0 - 160	100	yes	G 1/2	22	1.0
GGY-1002	*155137	0 - 250	100	yes	G 1/2	22	1.0
GGY-1003	*155144	0 - 400	100	yes	G 1/2	22	1.0
GGY-2500	*155113	0 - 2500	100	yes	G 1/2	22	1.6

\*GGY-1001 SZ = with maximum pointer



## Pressure gauge model GYA-63

Consisting of pressure gauge GGY-632 (diameter Ø 63 mm, glycerine-damped) and corresponding gauge adaptor. This pressure gauge set is suitable for connection to all HPS hand pumps.

Assembled ready to use, compact design with 45° inclination for easy reading.

### Technical data model GYA-63

Model	EAN-No. 4025092*	Pressure gauge bar	Oil port pump	Oil port hose	Weight kg
GYA-63	*156103	0 - 1000 bar, Ø 63 mm, glycerine-damped	3/8-NPT outer	3/8-NPT inner	0.5

### Pressure gauge adaptor model GA

Gauge connection with sleeve nut and 30° inclination for easy reading.

Suitable for all hand pumps series HPS.



#### Technical data model GA

Model	EAN-No. 4025092*	Oil port gauge	Oil port pump	Oil port hose
GA-700	*155557	G 1/4	3/8-NPT outer	3/8-NPT inner
GA-701	*155588	G 1/2	3/8-NPT outer	3/8-NPT inner

### Pressure gauge adaptor model GA

For double-acting hand pumps model HPH, for mounting between 4/2-directional valve and hand pump.

#### Features

- Advantage: shows both the pushing force and the pulling force of the connected hydraulic cylinder.
- 30° inclination for easy reading.
- Pressureless return line by means of telescopic double nipple.



#### Technical data model GA

Model	EAN-No. 4025092*	Oil port gauge	Oil port	Telescopic nipple
GA-703	*155564	G 1/2	2 x 3/8-NPT outer	2 x 1/4-NPT outer
GA-704	*156172	G-1/4	2 x 3/8-NPT outer	2 x 1/4-NPT outer

### Pressure gauge adaptor model GA-2000

This pressure gauge adaptor is suitable for connection to all TWAZ hand pumps (2000 bar). Suitable for pressure gauge GGY-2500.



#### Technical data model GA-2000

Model	EAN-No. 4025092*	Operating pressure max. bar	Oil port gauge	Oil port pump	Oil port hose
GA-2000	*155915	2000	G 1/2	M22 x 1.5 outer (with seal cone)	M22 x 1.5 inner (for FY - 201)





## Hydraulic couplers models CFY, CMY, CCY

Yale hydraulic couplers are self-sealing which means that the coupler halves only have to be closed hand-tight. Both female and male parts have inner balls which seal the coupler halves in uncoupled condition, so that no hydraulic fluid will leak.

Please note that all Yale hydraulic cylinders are equipped with the standard female coupler half CFY-1 and dust cap CDF-9.

### Technical data models CFY, CMY and CCY

Model	EAN-No. 4025092*	Description	Connection thread	Pressure max. bar
CFY-1	*155489	Coupler half, female (standard)	3/8-NPT, outer	700
CFY-2	*155960	Coupler half, female	3/8-NPT inner	700
CFY-18	*155922	Coupler half, female	M18x1.5 outer	700
CFY-10-S	*156400	Coupler half, female	Pipe Ø 10 mm	700
CMY-1	*155496	Coupler half, male	3/8-NPT, inner	700
CCY-1	*155472	Coupler halves, female + male	3/8-NPT	700
CDF-9*	*155885	Dust cap, rubber	-	-

\*fits to female and male coupler halves (standard with all female coupler halves)

### Dimensions models CFY, CMY and CCY

Model	CFY-1	CFY-2	CFY-18	CFY-10-S	CMY-1	CCY-1
A, mm	-	-	-	-	-	85
B, mm	72	78	72	72	-	-
C, mm	-	-	-	-	38	-
D, mm	35	35	35	35	-	-
E, mm	24	27	24	24	-	-
F, mm	-	-	-	-	32	-

**Hydraulic couplers must always be completely closed, since otherwise the circulation cannot be released.**

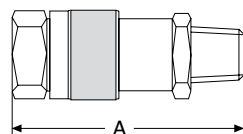

Coupler complete CCY-1

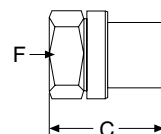

Coupler half, male CMY-1

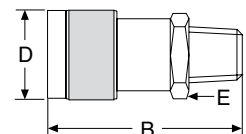

Coupler half, female CFY-1

## Hydraulic hoses model HHC

Durable but highly flexible thermoplast hydraulic hoses guarantee a very long life.

The 4-layer build-up includes 2 layers of high tensile steel fabric and robust fitting with 19 mm hexagon.

The volumetric expansion is very low. Hydraulic hoses model HHC...are equipped with a male coupler half as standard.

Standard length are as per the chart below, further lengths or hoses with larger diameters are quoted on request.



### Technical data model HHC

Model	EAN-No. 4025092*	Length	Width	Operating pressure	Burst pressure	Connection 2 male coupler half CMY-1	Connection 1 thread nipple 3/8-NPT, outer	External diameter approx.	Bend radius min.	Width
		m	mm	bar	bar			mm	mm	mm
HHC-5	*155786	0.5	6.3	700	2800			14	100	6.3
HHC-10	*155687	1	6.3	700	2800			14	100	6.3
HHC-20	*155380	2	6.3	700	2800			14	100	6.3
HHC-30	*155793	3	6.3	700	2800			14	100	6.3
HHC-40	*155397	4	6.3	700	2800			14	100	6.3
HHC-60	*155595	6	6.3	700	2800			14	100	6.3
HHC-80	*155731	8	6.3	700	2800			14	100	6.3
HHC-100	*155809	10	6.3	700	2800			14	100	6.3
HHC-120	*156370	12	6.3	700	2800			14	100	6.3
HHC-150	*156387	15	6.3	700	2800			14	100	6.3

### How to order

#### Hydraulic hose for all standard combinations (- pump - hose - cylinder -):

Order a standard hose with female coupler half model HHC... (e.g. HHC-20).

#### Hydraulic hose for coupling connections on both sides (both ends with CMY-1):

Order a complete coupler CCY-1 in addition to a standard hose model HHC... (recommended for long hydraulic hoses).

#### Hydraulic extension hose

##### (one male coupler half, one female coupler half):

Order a female coupler half CFY-2 (inner thread) in addition to a standard hose model HHC.

#### Hydraulic hose without any coupler parts

##### (both ends with threaded nipples):

Order model HH... (both ends 3/8-NPT outer).











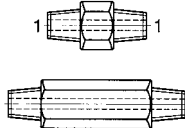

## Fittings, reducers, connectors model FY

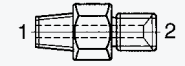
Fittings are useful for versatile combinations of hydraulic cylinders.

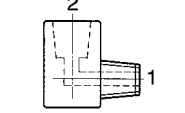

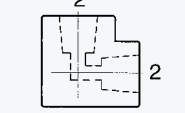

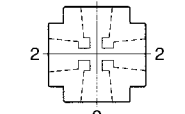

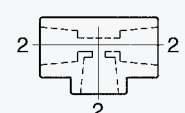



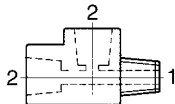

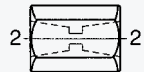

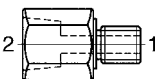
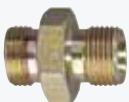
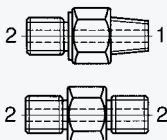

Yale high pressure fittings have been designed to give a variety of connections, extensions and combinations. The fittings are designed for a max. system pressure of 700 bar.

For improved sealing of 3/8 NPT connections use 2 layers of teflon tape and tighten accordingly.

### Technical data model FY

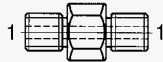
Model	EAN-No. 4025092*		Description	Figures	Connection 1	Connection 2
FY-1 FY-1L	*155403 *156219		Double nipple Double nipple, long		3/8 NPT outer 3/8 NPT outer	- -
FY-13 FY-17 FY-18	*155656 *155816 *155823		Double nipple		1/4 NPT outer 3/8 NPT outer 3/8 NPT outer	R 1/4 outer M14x1.5 (for sleeve nut) R 1/4 outer
FY-2	*155410		Elbow		3/8 NPT outer	3/8 NPT inner
FY-3	*155427		Elbow		-	3/8 NPT inner
FY-6	*155458		Cross		-	3/8 NPT inner
FY-4	*155434		Tee		-	3/8 NPT inner

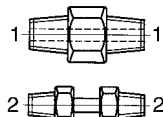
## Technical data model FY

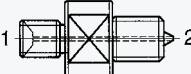
Model	EAN-No. 4025092*		Description	Figures	Connection 1	Connection 2
FY-5	*155441		Tee		3/8 NPT outer	3/8 NPT inner
FY-7 FY-11	*155465 *155649		Connection		-	3/8 NPT inner 1/4 NPT inner
FY-8 FY-9	*155540 *155632		Adaptor		3/8 NPT outer 1/4 NPT outer	R 1/2 inner 3/8 NPT inner
FY-10 FY-12	*155663 *155670		Adaptor		3/8 NPT outer 1/2 NPT outer	1/4 NPT inner 3/8 NPT inner
FY-16 FY-19 FY-20 FY-30 FY-33	*155748 *155830 *155847 *156318 *156592		Adaptor		3/8 NPT outer M18x1.5 outer M14 outer G 3/8 outer 3/8 NPT outer	M18x1.5 inner 3/8 NPT inner 3/8 NPT inner 3/8 NPT inner M14x1.5 inner
FY-26 FY-27	*156196 *156202		Double nipple		3/8 NPT outer G 3/8 outer	G 3/8 outer G 3/8 outer
FY-31 FY-32	*156325 *156332		Connection		3/8 NPT inner 3/8 NPT inner	M18x1.5 inner M20x1.5 inner
FY-35	*156608		Double nipple		M 14 outer	-
FY-703	*155571		Connecting set for 4/3-way valve to HPS hand pumps (telescopic nipple)		3/8 NPT outer	1/4 NPT outer
FY-201	*156011		Hose connector for TWAZ hand pumps 2000 bar		R1/4 outer	M22x1.5 outer (with seal cone)



## Hydraulic puller with integrated hydraulics model BMZ

Pulling force max. 6, 8 and 11 t

Hydraulic pullers are a valuable tool for the maintenance engineer. The pullers allow time and cost savings as they offer high working safety and can be operated in all positions. Hydraulic pullers are used in all kinds of industries, workshops and in many repair and assembly jobs to remove or install interference fit parts, such as: gears, couplings, bearings, wheels, pulleys, axles, shafts, break drums and many other press fit components. Damage to parts is minimized through the use of controlled hydraulic power, whilst machine down-time can be reduced drastically.

### Features

- Drop-forged alloy steel jaws.
- Hard chromium plated piston, spring return.
- No radial moment of torsion.
- No spindle wear.
- Integrated hydraulic cylinder and pump.
- Quick adjustment with trapezoid speed nut.
- 3 and 2-jaw design.
- Pump lever can rotate through 360°.
- Piston with durable, spring loaded centering tip.
- Supplied in a sturdy plastic box.

### Technical data model BMZ

Model	EAN-No. 4025092*	Pulling force max. t	Piston stroke mm	Weight kg
BMZ-6	*154499	6	82	4.9
BMZ-8	*154505	8	82	6.6
BMZ-11	*154512	11	82	8.0

### Dimensions model BMZ

Model	BMZ-6	BMZ-8	BMZ-11
Reach max. A, mm	160	200	230
Diameter Ø max. B, mm	200	250	280
Length C, mm	320	320	345

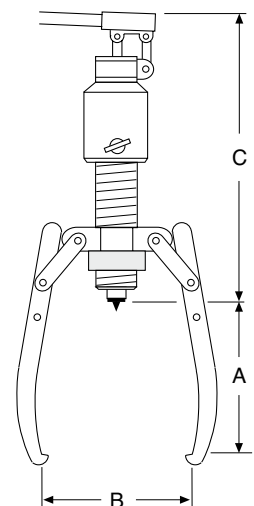





## Puller sets with separate hydraulics 10, 15 and 23 t model BMZ

Pulling force max. 10 - 23 t

The harder the pulling force, the tighter the grip of the jaws. Longer jaws up to 1000 mm are available on request.

### Features

- High quality components from our standard hydraulic program.
- Modular system, hydraulic parts can also be used for many other applications.
- Long-life hydraulic cylinders manufactured from chromium-molybdenum steel.
- Two-stage quick-action hand pumps.
- Incl. high pressure hydraulic hose with quick coupler, L = 2.0 m.
- All complete sets are supplied in metal box model HPK-10 or wooden case.
- All sets are supplied ready to use.

### Scope of delivery:

- Pressure gauge set model GYA-63.



Accessories for model BMZ-2311:  
Model BMZ-2308 extensions of pulling arms increase the reach (A) up to 400 mm.  
Model BMZ-2309 up to 500 mm.



Pressure gauge set model GYA-63 is part of the scope of delivery.

## Model BMZ-1000 and 1510

The harder the pulling force, the tighter the grip of the jaws. Longer jaws up to 1000 mm are available on request.

## Model BMZ-2311

The radially adjustable pulling arms can be locked in any position.



## Technical data model BMZ

Model	EAN-No. 4025092*	Pulling force max. t	Hydraulic cylinder model	Hand pump model	Hydraulic hose model	Lift of the cylinder mm	Weight kg
BMZ-1000	*154529	10	without	without	without	-	9.5
BMZ-1010	*154536	10	with YS-10/150	with HPS-2/0.7 A	HHC-20	150	21.5
BMZ-1500	*154543	15	without	without	without	-	9.5
BMZ-1510	*154550	15	with YS-15/150	with HPS-2/0.7 A	HHC-20	150	23.5
BMZ-2300	*154567	23	without	without	without	-	28.0
BMZ-2311	*154482	23	with YS-23/160	with HPS-2/0.7 A	HHC-20	160	45.0

## Dimensions model BMZ

Model	BMZ-1000	BMZ-1500	BMZ-2300
Reach max. A, mm	300	300	300
Diameter Ø max. B, mm	350	350	700

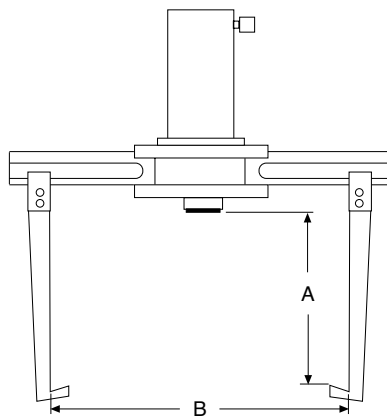
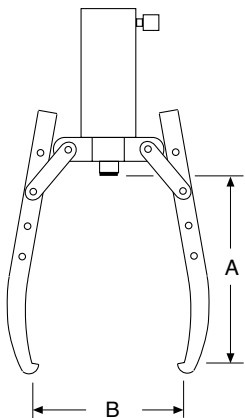

## Hydraulic puller sets model YHP

Pulling force max. 10 - 50 t

These professional puller sets are designed for removing and installing press-fitted or heat-fitted parts. Hydraulic puller sets eliminate time-consuming and costly repairs as they avoid the damage of parts and reduce machine downtimes. All parts are manufactured from high quality drop-forged steel.

### Scope of delivery

The complete sets are supplied ready to use and include all necessary components such as hollow cylinder, hydraulic hand pump, pressure gauge (to control the pulling force) and 2 meter hydraulic hose with quick-connect coupler.



## 3-Grip puller sets

For all pulling jobs where solid parts have to be removed, e.g. gears, belt pulleys, sprockets, flywheels, couplers, shafts, axles etc. The sets can be used as both 3-jaw and 2-jaw puller.

Model	EAN-No. 4025092*	Pulling force max. t
YHP-252 G	*161992	20
YHP-352 G	*162005	30
YHP-552 G	*162012	50

Combinations with "slotted cross heads" have to be operated with limited pull capacities, according to the owners manual.



## Cross-bearing puller sets

For all pulling jobs where multi-segmented parts have to be removed: ball bearings, roller bearings and similar parts. Puller sets are supplied complete with bearing puller attachment and bearing cup puller.

Model	EAN-No. 4025092*	Pulling force max. t
YHP-262 G	*162029	10
YHP-362 G	*162036	20
YHP-562 G	*162043	25

## Multi-purpose puller sets

These multi-purpose puller sets are universal combinations of both a.m. sets and include all necessary parts from 3-grip puller set and crosshead puller set.

Model	EAN-No. 4025092*	Pulling force max. t
YHP-2752 G	*161787	20/10
YHP-3752 G	*161824	30/20
YHP-5752 G	*162050	50/25



## Type of puller set

Model	3-grip puller set			Crosshead puller set			Multi purpose puller set		
	YHP-252 G	YHP-352 G	YHP-552 G	YHP-262 G	YHP-362 G	YHP-562 G	YHP-2752 G	YHP-3752 G	YHP-5752 G
EAN-No. 4025092*	*161992	*162005	*162012	*162029	*162036	*162043	*161787	*161824	*162050
Capacity, t	20	30	50	10	20	25	20/10	30/20	50/25
Hand pump, model HPS-1/07 A (part 1)	•	•	–	•	•	–	•	•	–
Hand pump, model HPS-2/2 A (part 1)	–	–	•	–	–	•	–	–	•
Pressure gauge set, model GYA-63 (part 2)	•	•	•	•	•	•	•	•	•
Hydraulic hose, model HHC-20 (part 3)	•	•	•	•	•	•	•	•	•
Hollow cylinder (part 4), model	YCS-21/50	YCS-33/60	YCS-57/70	YCS-21/50	YCS-33/60	YCS-57/70	YCS-21/50	YCS-33/60	YCS-57/70
Triple crosshead (part 5)	•	•	•	–	–	–	•	•	•
Double crosshead (part 6)	•	•	•	–	–	–	•	•	•
Grip arm, 3 pcs. (part 8)	•	•	•	–	–	–	•	•	•
Spindle (part 9)	•	•	•	•	•	•	•	•	•
Strap, 6 pcs. (part 10)	•	•	•	–	–	–	•	•	•
Strap screws + strap nuts, 6 pcs. (part 11)	•	•	•	–	–	–	•	•	•
Mounting screws, 2 pcs. (part 13a)	•	•	•	–	–	–	•	•	•
Mounting screws, 2 pcs. (part 13b)	–	–	–	•	•	•	•	•	•
Saddle with internal thread (part 14)	•	•	•	•	•	•	•	•	•
Smooth saddle (part 15)	•	•	•	•	•	•	•	•	•
Slotted crosshead (part 16)	–	–	–	•	•	•	•	•	•
Slide plate, 2 pcs. (part 17)	–	–	–	•	•	•	•	•	•
Nut, 2 pcs. (part 18)	–	–	–	•	•	•	•	•	•
Washer, 2 pcs. (part 19)	–	–	–	•	•	•	•	•	•
Pulling leg, short, 2 pcs. (part 20), mm	–	–	–	280	255	455	280	255	455
Pulling leg, long, 2 pcs. (part 21), mm	–	–	–	460	505	773	460	505	773
Leg end, 2 pcs. (part 24)	–	–	–	•	•	•	•	•	•
Leg connector, 2 pcs. (part 25)	–	–	–	•	•	•	•	•	•
Bearing puller attachment (part 26)	–	–	–	•	•	•	•	•	•
Bearing cup pulling attachment (part 27)	–	–	–	•	•	•	•	•	•
Storage case (part 29)	•	•	•	•	•	•	•	•	•
Weight, kg	40	65	120	46	86	156	91	172	295

The symbols stand for: • including complete set, – not included

## Dimensions hydraulic puller set model YHP

Model	20 t	30 t	50 t
3-grip A, mm	300	520	700
C, mm	0 - 817	0 - 977	0 - 1233
3-grip B, mm	500	900	1200
D, mm	25 - 155	30 - 250	75 - 330
2-grip A, mm	300	520	700
E, mm	152	250	330
2-grip B, mm	420	700	1000
F, mm	140	150	150
G, mm	30 - 180	75 - 230	75 - 230

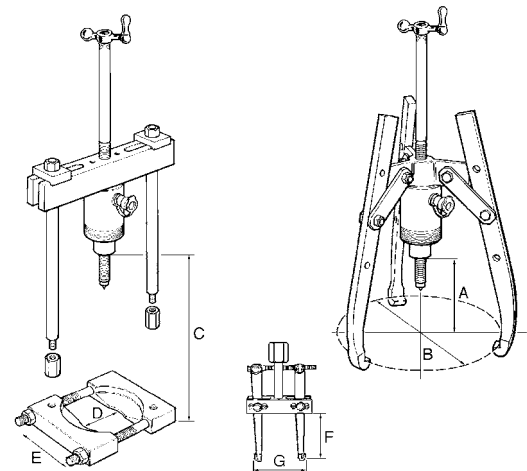



AJH-620

AJS-65

AJS-104

## Aluminium hydraulic jacks model AJH and model AJS

### Capacities from 6.5 - 100 t

Aluminium jacks combine light weight with high lifting capacity. The use of high tensile aluminium alloy allows lifting capacities of up to 100 tons resulting in a very favourable 1.8 tons lifting capacity per 1 kg weight ratio. Operation of Yale hydraulic jacks is very simple. Jacks are supplied ready for use, i.e. including hydraulic oil, operating lever and, where applicable, carrying handle and lifting claw.

### Aluminium jacks with lifting claw

Jacks from 20 tons are available with a lifting claw. In this case the jacks are provided with an elongated base plate. The max. permissible working load of the lifting claws is 40% of the jack capacity.

### Aluminium jacks with safety lock nut

Jacks from 20 tons can be supplied with a safety lock nut. This device allows absolute safe jacking over a long period. In this case the hydraulic jack can be operated like a mechanical support and the hydraulic system can be totally released.

### Application

Hydraulic jacks are universally popular tools for use in workshops or on site for all kinds of lifting and assembly applications, for construction, shipbuilding, power plants, general engineering, metal fabrication and many more. Applications are unlimited. Standard jacks with plain piston and jacks with safety lock nuts cannot be used with a lifting claw. To increase stability, all jacks with long stroke (305 mm) are equipped with an elongated base plate.

### Features

- Strokes from 75 - 305 mm.
- Extremely low weight.
- The 6.5 and 10 tons jacks can be operated in any position (also upside down) and are equipped with spring return piston and stop ring.
- The 20 to 100 tons jacks can be operated vertically or with front face in horizontal position.
- All jacks are provided with an overload protection valve.
- From 20 tons capacity with additional mechanical stroke limiter.
- All jacks with hardened alloy steel saddle and sensitive lowering valve which is activated by the operating lever.



AJH-630  
SR

## Technical data model AJH and model AJS

Model	EAN-No. 4025092*	Capacity t	Capacity of lifting claw max. t	Lift mm	Overall height mm	Base plate mm	Height of lifting claw min. mm	Weight kg
AJS-65	*157995	6.5	–	75	131	159x76	–	3.6
AJS-104	*158015	10	–	115	182	171x76	–	6.3
AJH-620	*158046	20	–	152	265	180x120	–	10.9
AJH-1220	*158107	20	–	305	440	250x120	–	16.7
AJH-630	*158169	30	–	152	265	200x140	–	15.4
AJH-1230	*158220	30	–	305	452	275x140	–	23.4
AJH-660	*158282	60	–	152	293	250x190	–	27.4
AJH-1260	*158343	60	–	305	500	340x190	–	43.7
AJH-6100	*158404	100	–	152	315	305x250	–	49.0

### Jacks with lifting claw

Model	EAN-No. 4025092*	Capacity t	Capacity of lifting claw max. t	Lift mm	Overall height mm	Base plate mm	Height of lifting claw min. mm	Weight kg
AJH-620 C	*158060	20	8	152	280	250x120	67	14.5
AJH-1220 C	*158121	20	8	305	452	250x120	67	22.2
AJH-630 C	*158183	30	12	152	284	275x140	72	20.3
AJH-1230 C	*158244	30	12	305	472	275x140	72	31.0
AJH-660 C	*158305	60	24	152	327	340x190	72	43.1
AJH-1260 C	*158367	60	24	305	533	340x190	72	64.9

### Jacks with safety lock nut

Model	EAN-No. 4025092*	Capacity t	Capacity of lifting claw max. t	Lift mm	Overall height mm	Base plate mm	Height of lifting claw min. mm	Weight kg
AJH-620 SR	*158084	20	–	152	291	180x120	–	10.9
AJH-1220 SR	*158145	20	–	305	464	250x120	–	16.7
AJH-630 SR	*158206	30	–	152	294	200x140	–	15.4
AJH-1230 SR	*158268	30	–	305	480	275x140	–	23.4
AJH-660 SR	*158329	60	–	152	330	250x190	–	27.4
AJH-1260 SR	*158381	60	–	305	536	340x190	–	43.7
AJH-6100 SR	*158428	100	–	152	366	305x250	–	53.0



# Hydraulic Jacks & Tools



## Machine jacks with lifting claw model YAM

### Capacity 2 - 15 t

Machine jacks with lifting claw are used in applications where space below the load is restricted, thus preventing the use of traditional lifting equipment.

Typical applications for machine jacks are lifting, positioning and transportation of machines, heavy steel constructions or similar loads, as well as general repair and assembly applications.

The jacks are also useful for applications like leveling of high-rise warehouses, heavy-duty scaffolds, large frame-works etc.

### Features

- Offers safe lifting of machines with an extremely low clearance.
- Incl. safety pressure valve to prevent overload.
- Large base offers increased stability under load.
- Pump lever can rotate through 270° (excluding YAM-2).
- Same load can be lifted on either the head or the claw of jack.
- Spring return of the lifting claw (only YAM-5 and YAM-10).
- Precision-adjustable lowering valve.
- Jacks are supplied ready to use incl. pump lever, and are filled with oil.



### Technical data model YAM

Model	EAN-No. 4025092*	Capacity on the claw t	Lift mm	Weight kg
YAM-2	*157711	2	113	8
YAM-5	*153997	5	120	19
YAM-10	*154000	10	145	38
YAM-15	*157728	15	140	41

### Dimensions model YAM

Model	YAM-2	YAM-5	YAM-10	YAM-15
A, mm	235	290	325	336
B, mm	180	257	280	292
C, mm	125	182	240	240
D, mm	50	75	100	85
E, mm	50	57	60	60
F, mm	85	117	150	110
G, mm	16	22	28	28

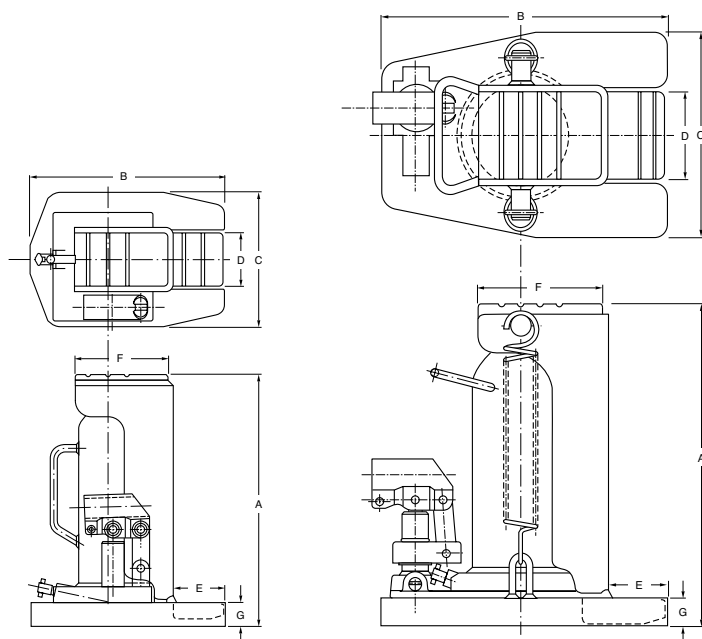



## Hydraulic machine jacks model YAP

Capacity 4.5 - 50 t

Hydraulic machine jacks are designed for the safe lifting and positioning of machines and similar heavy equipment.

### Features

- These jacks are operated with external pumps, e.g. hand or motor pumps but also with synchronous power packs.
- The compact construction allows operation even in extremely confined areas.
- 3 hook-in positions of the lifting claw provide high flexibility (model YAP-5130 4 hook-in positions).
- The load can be lifted with either the lifting claw or with the head of the jack.
- Welded, distortion-proof steel construction.
- High quality, durable hydraulic components.
- The flat lifting claw allows low jacking height.
- Safe stability due to swivel-mounted support feet.
- The connection between jack and pump is made by a hydraulic hose.
- The jacks are delivered ready-to-use inclusive of carrying handles and coupling half.



### Technical data model YAP

Model	EAN-No. 4025092*	Capacity t	Lift mm	Height for applications min. mm	Pressure max. bar	Weight approx. kg
YAP-5130	*160018	4.5	133	15	700	13.5
YAP-10150	*160025	10	155	20	700	23.0
YAP-15150	*160032	15	155	25	700	40.0
YAP-25150	*160049	23	155	30	700	60.0
YAP-50150	*160056	50	155	35	700	165.0

### Dimensions model YAP

Model	YAP-5130	YAP-10150	YAP-15150	YAP-25150	YAP-50150
A min., mm	15	20	25	30	35
A max., mm	232	273	291	300	375
B, mm	228	277	328	387	540
H, mm	252	283	316	330	405
L, mm	161	194	245	278	375

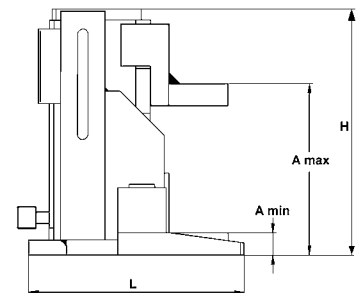
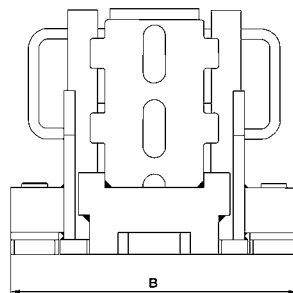

## Hydraulic machine jacks model YAS

### Capacity 3 - 25 t

Hydraulic machine jacks are designed for the safe lifting and positioning of machines and similar heavy equipment.

### Features

- Integrated hydraulic pump.
- Pump lever swivel mounted 270° for operation even in extremely confined areas.
- Same load can be lifted on either the head or the claw of jack.
- Welded, distortion-proof steel construction.
- High quality, durable hydraulic components.
- The flat lifting claw allows low jacking height.
- The additional connect coupler (10 t capacity and larger) for external pump operation, allows connection of hand, motor or synchronous lifting pumps (max. pressure 520 bar).
- Safe stability due to swivel-mounted support feet.
- Sensitive lowering valve for slow lowering of loads without jerks.
- When operating the jack with an external pump the installation of a manometer is mandatory.
- The integrated hydraulic pump is protected by a pressure-limiting valve.
- The jacks are delivered ready-to-use inclusive of carrying handles, hydraulic oil filling and pump lever.



### Technical data model YAS

Model	EAN-No. 4025092*	Capacity t	Lift mm	Height for applications min. mm	Pressure max. bar	Weight approx. kg
YAS-3	*160063	3	140	12	520	15.0
YAS-5	*160070	5	140	15	520	19.0
YAS-10	*160087	10	140	20	520	28.0
YAS-15	*160094	15	140	25	520	50.0
YAS-25	*160100	25	140	30	520	72.0

### Dimensions model YAS

Model	YAS-3	YAS-5	YAS-10	YAS-15	YAS-25
A min., mm	12	15	20	25	30
A max., mm	230	232	300	291	300
B, mm	207	228	277	328	387
H, mm	250	252	252	316	330
L, mm	198	216	271	345	388

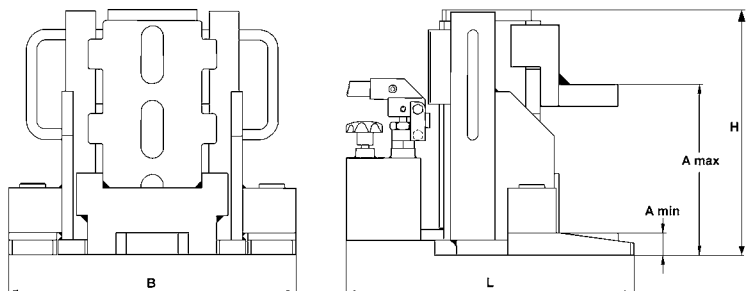

### Hydraulic stage lifts model ST

#### 50 up to 200 t capacity

For compact, low-headroom and universal applications. Stage lifts are hydraulic lifting devices which are designed to lift and lower loads over high distances.

Stage lifts overcome the usual limitations of their lifting height imposed by stroke length. Stage lifts operate with “double-acting” hydraulic cylinders (return stroke by hydraulic pressure) and are equipped with a load spreading plate and a piston support plate.

#### Operation

A stage lift operates inverted and lifts the load via the bottom of the cylinder whilst it climbs on a pile of support bars (wood or aluminium). In principle, the load can be lifted to any height although stage lifts are still compact and versatile for low-headroom lifting applications.

The simple “3-step operation” eliminates the need for additional holding arrangements and the repositioning or replacing of cylinders which are normally required for a higher lifting distance. A stage lift climbs up and down on its own.

#### Control

Depending on the power pack, selected stage lifts can be controlled individually (by hand or motor pump) or together in a synchronized arrangement with multi-flow pumps.

#### Features

- Yale ChroMo-Design.
- Low-cost lifting systems possible, (3-point resp. 4-point).
- Low weight (e.g. 60 kg for a 50 t unit).
- Stage lift body made from high-grade aluminium.
- Hydraulic cylinders are made from robust chromium-molybdenum steel with double bronze bearings ensure a longlife service system.
- Large-diameter tilt saddle.
- Incl. coupler halves and carrying handles on request.



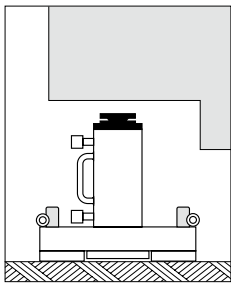

1. Stage: Initial position, stage lift rests on the ground under the load.

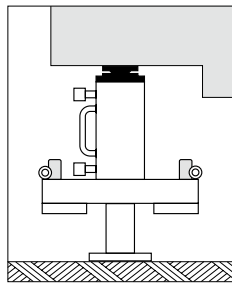

2. Stage: Step 1, load is raised.

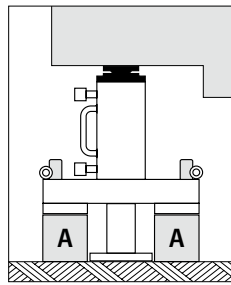

3. Stage: Two support bars type "A" are positioned in place.

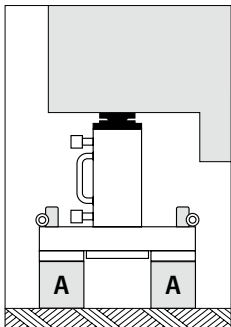

4. Stage: Piston is retracted and load rests on support bars type "A".

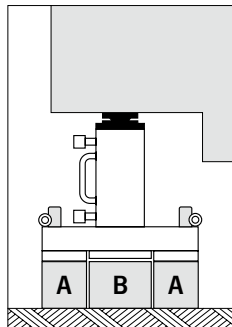

5. Stage: Broader middle bar type "B" is inserted.

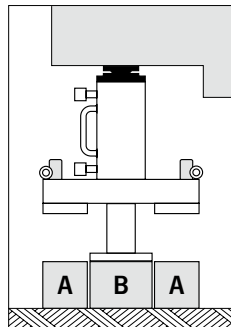

6. Stage: Step 2, load raised on broader middle bar "B".

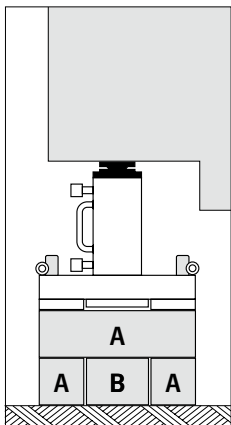

7. Stage: Two bars "A" are inserted and rotated at 90°, piston is retracted and middle bar is inserted.

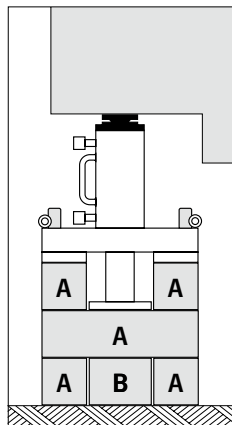

8. Stage: Load is lifted on middle bar (3rd step), two support bars type "A" are positioned at 90° and load rests on support bars "A".

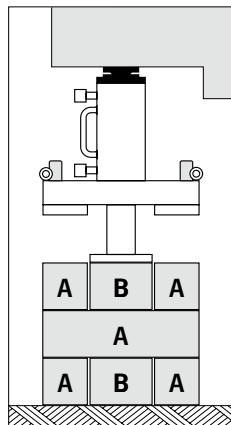

9. Stage: Piston is retracted, middle bar type "B" is inserted and lifts the 4th step on middle bar "B" and so on...

## Technical data model ST

Model	EAN-No. 4025092*	Capacity max.	Stroke	Overall height	Load-spreading plate Ø	Piston plate Ø	Weight approx.
		t	mm	mm	mm	mm	kg
ST-5015	*157810	50	150	396	425 x 425	160	60
ST-10015	-	100	150	455	525 x 525	180	115
ST-20015	-	200	150	510	600 x 600	210	196

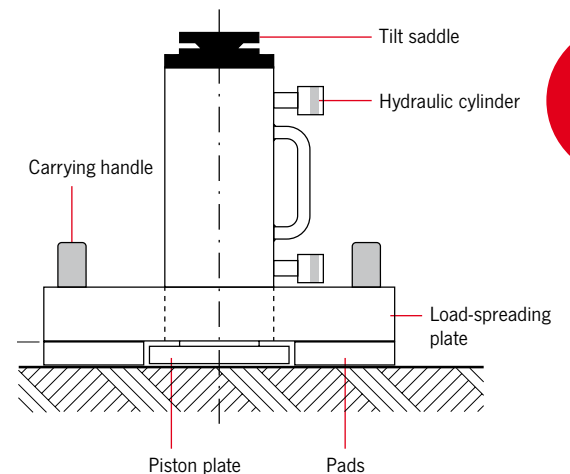



## Hydraulic spreader model YHS

Capacity max. 0.5 - 1.5 t

These universal power tools can be used for all repair, maintenance and assembly work requiring precisely controlled power, e.g. aligning of containers and shells, lifting, positioning or aligning of machinery and structural components, forcing-off of shutterings and moulds. Applications are unlimited.

The spreaders can be operated with all hand pumps.

### Features

- Operating pressure max. 700 bar.
- Single-acting with spring return.
- Works in all positions.
- Spreader arms of high-tensile steel.
- Incl. female coupler half CFY-1 with dust cap.

### Technical data model YHS

Model	EAN-No. 4025092*	Capacity max. kN	Capacity max. t	Operating pressure max. bar	Oil volume max. cm <sup>3</sup>	Spread width min. mm	Spread width max. mm	Weight kg
YHS-05	*157650	5	0.5	700	10	16	100	1.9
YHS-11	*154741	10	1.0	700	10	14	100	2.1
YHS-15	*154673	15	1.5	700	70	35	220	6.9



## Hydraulic chain cutter model YCC-200

This hydraulic chain cutter has been designed for cutting high-tensile, grade 10 chains up to a material diameter of 16 mm.

The open design allows easy positioning of the chain.

The unit can be operated using the standard hand or motor pumps.

Recommended pump:

Electric power pack model PY-04/2/5/2M

### Features

- Protection flap with acrylic glass pane allows safe monitoring of cutting process
- Opening in base plate allows chips and splinters to fall down through the body for removal
- Special chain support device for cutting larger chains

- Cutting performance:
 

max. material dimension Ø:	20 mm
max. material dimension grade 10 Ø:	16 mm
max. cutting force:	23 t
Weight:	37.4 kg
- Solid, stable and rigid body
- Built-in standard hydraulic cylinder, single-acting with spring return
- Both through-hardened cutting blades are identical in construction, can be re-sharpened and are easy to remove

## Hydraulic propeller press system model PPS

Operating pressure max. 2000 bar

The hydraulic propeller press system is used to press-fit large propellers onto the drive shaft of ships.

To this end the special flat cylinders can be linked together to build a chain of any length and press force. The cylinders are provided with appropriate link eyes at both sides.

The max. operating pressure of 2000 bar ensures high pressure forces up to 1600 t or more.

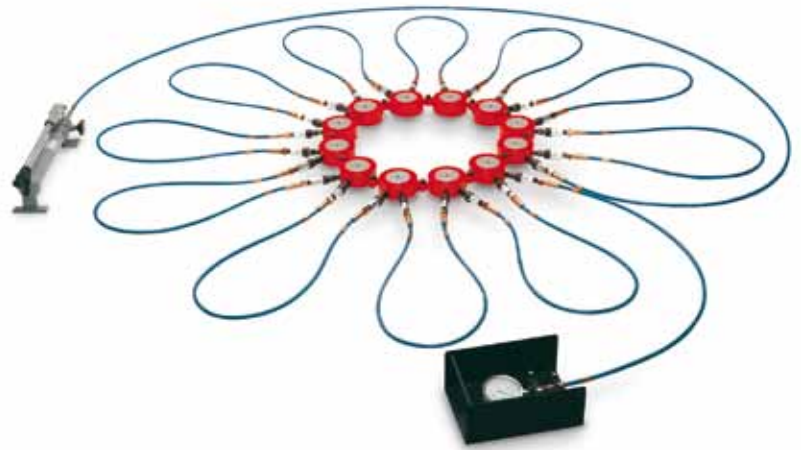

A complete hydraulic propeller press system with 12 cylinders with a total capacity of 1200 tons. The system is complete with appropriate connecting hoses with quick-release couplers, pressure gauge up to 2500 bar and hand pump model TWAZ-2.3. All parts are designed for a maximum operating pressure of 2000 bar.

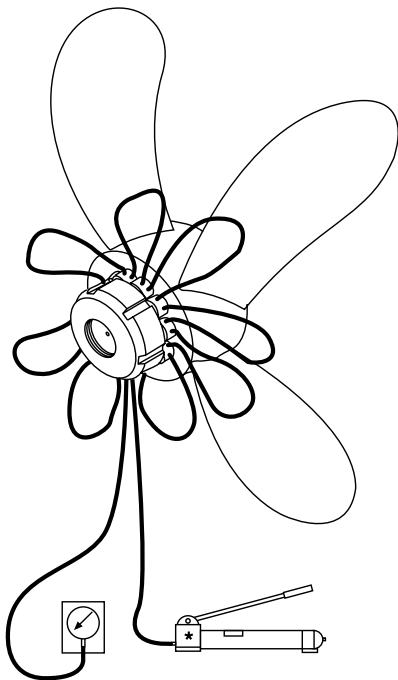

### Special flat hydraulic cylinder

**With link connections at both sides and 2 male quick connect coupler halves**

Capacity max. 100 t.

Stroke 10 mm.

Pressure max. 2000 bar.

Diameter 127 mm.

Closed height 50 mm.



### Link plates and lifting hooks

They are used to connect the cylinders and to handle the complete chain with a crane. 2 pieces of link plates and lifting hooks as well as the corresponding number of high-pressure hoses (with female quick connect couplers at both ends) belong to a complete set.





## Hydraulic test rig for hoisting equipment model RPYS-1215

Capacity max. 12 t

For testing pul-lifts, lever hoists, chain blocks, wire rope pullers as well as other lifting equipment after repair or inspection.

### Testing of hoisting equipment

The lifting unit is placed between upper and lower shackle, the chain is tensioned against the oil cushion of the partly advanced piston of the hydraulic cylinder. The applied force can be read at the pressure gauge.

### Testing of the hoist brake

For a functional test of the hoist brake the hand pump may be used to apply a counter pressure and thus increase the pulling force after a general test.

### Frequent use

For frequent testing, the hand pump may be replaced by a low-cost air hydraulic (model PAY-6) or electric pump (model PY-04/2/5/2 M).

### Pressure gauge

To read pulling forces more easily, the test rig is equipped with two high-quality pressure gauges.

Quick couplers allow an easy replacement of pressure gauges.

Pressure gauge 1 for small test items: model: GGY-1005, display: 0-160 bar, Ø 100 mm, Kl. 1.0 %

Pressure gauge 2 for big test items: model: GGY-1003, display: 0-400 bar, Ø 100 mm, Kl. 1.0 %

### Mounted hollow cylinder model YCS-21/150

#### Single-acting, with spring return

- Chromium-molybdenum steel, heat-treated with bronze bearings.
- Pressure-/pulling force: 120 kN (12 t).
- Operating pressure: 0 - 400 bar.
- Center hole Ø: 27 mm.

### Mounted hydraulic hand pump model HPS-2/0,7A

#### Two-stage, with quick action

- Operating pressure: 0 - 400 bar.
- Reservoir: 0.7 l.
- Fine-adjustment pressure relief valve.



**Features**

- Fully welded, low-strain press-frame.
- Upper and lower hook suspension by means of shackles, incl. two 5 tons pull-rings for smaller test units.
- Lateral pump table.
- Infinite adjustment of the pulling force.
- Chart for easy determination of test force.
- Removable lower suspension e.g. for testing of plate clamps.
- Base pre-drilled for mounting.
- High-quality hydraulic components.
- Hollow cylinder made from chromium-molybdenum steel, heat-treated, inside and outside with dirt wipers.
- Long cylinder stroke of 150 mm, piston hard chromium-plated with bronze bearings.
- High-strength threaded bar M27.
- Two-stage quick action hand pump.
- Fine-adjustment pressure valve.

**Technical data model RPYS**

Model	EAN-No. 4025092*
RPYS-1215	*157469

**Dimensions model RPYS**

Model	RPYS-1215
A, mm	2580 - 2730
B, mm	2160
C, mm	1840
D, mm	500
E, mm	630
F, mm	760
G*, mm	1030 - 1425
H, mm	750
J, mm	150
Weight, kg	225

\*700 mm with 5 t pull-rings

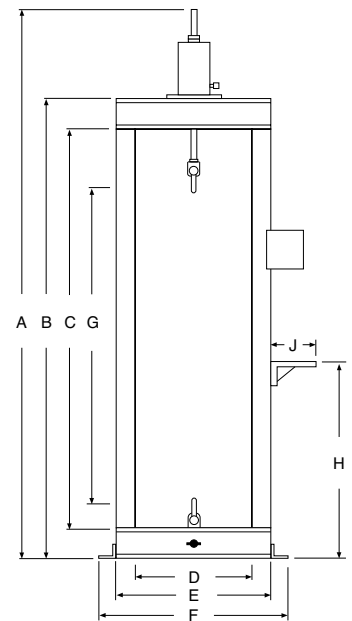

**The test rigs are delivered complete and ready to use.**



**Hydraulic test rig for steel winches model RPYS-1535**

Capacity max. 15 t

For the testing of steel winches or similar lifting devices we offer a specific test rig.

**Features**

- Max. capacity 15 t.
- With hydraulic cylinder model YS-15/350.
- Stroke: 350 mm.

**Scope of delivery**

- Incl. two-stage hand pump model: HPS-2/2 A.
- Fine-adjustment pressure valve 0-700 bar.
- Hydraulic hose 2 m, model: HHC-20.
- Pressure gauge model: GGY-1004, display: 0-700 bar, Ø 100 mm, Kl. 1.0 %.



RPY-10 up to 23

### Universal workshop presses model RPY and model RPES

Capacity 10 - 200 t

For all repair and assembly jobs.

According to European standards, all Yale workshop presses can be used without any additional protection devices as the piston speed is below 10 mm/sec.

For special applications additional safety equipment (e.g. protection grid or two-hand-safety-control) can be offered on request.

#### Applications

- Pressing and removing of bolts, shafts, bearings.
- Straightening of beams, profiles, axles, shafts.
- Forming, bending, crimping.
- General load tests and tests of weld specimens.
- Stamping, cutting, punching.
- Pre-adjustment of tools.

### Equipment of all presses

#### Features

- All workshop presses are ready to use, including hydraulic oil, oil level gauge.
- High pressure-hydraulic hoses.
- Glycerine-damped pressure gauges.
- Fixing holes in base profiles, adjusting device for press table and head, swivelling pump console, conversion chart: Pressure-force etc.

### Description of the hydraulic cylinders

#### Features

- Cylinders made from chromium-molybdenum steel, heat-treated and with metric mounting threads in the piston.
- Double bronze bearing of the hard chromium-plated piston.
- Piston return through spring or hydraulically.
- Mounting thread in the piston.
- Available piston strokes from 150 up to 500 mm.

### Description of the press-frame

#### Features

- Robust, torsion-resistant construction.
- Solid, precision-welded press-frames.
- Open construction, easily accessible from all sides.
- 50 and 100 tons workshop presses with adjustable press table and press head (frames for adjustments are part of the delivery package).
- 200 t press with adjustable table and fix welded press head.
- Four locking bolts ensure a precisely aligned press head and press table and increase the stability of the frame (50 and 100 t).
- 50, 100 and 200 t presses with pivoting pump table with peripheral passage for straightening of exceptionally long parts.
- Modular system: Large variety of combinations of hydraulic cylinders and pumps possible.
- Drive either by hand or electric hydraulic pumps.



RPY-50 up to 100

! The press head of the 200 t model is fix welded to the press-frame.

## Description of the hand pumps

### Features

- All hand pumps with two-stage displacement.
- Glycerine-damped pressure gauge, Ø63 mm, class 1.6 %.
- Hydraulic hose, L = 2.0 m with male coupler half.

## Description of the hydraulic power packs

### Features

- Longlife radial piston pumps, from 50 t with two-stage displacement.
- Pressure pre-set valve on request (standard equipment for the solenoid valves).
- Glycerine-damped pressure gauge, Ø 100 mm, class 1.0 %.
- Control by manual directional valve (with motor start-stop remote control) or solenoid valve with pendant remote control box.



RPES 10 up to 30

## Technical data model RPY and model RPES

Model	EAN-No. 4025092*	Frame design	Capacity t	Cylinder model	Cylinder stroke mm	Piston return	Type of pump	Control valve	Pump model
RPY-1015 M-2	*157346	bench press	10	YS-10/150	150	spring	manual	manual	HPS-2/0,7 A
RPY-1025 EM-PYE 07	*250214	bench press	10	YS-10/250	250	spring	electric	manual	PYE-07/3/10/3M-RPY
RPY-2316 M-2	*157360	bench press	23	YS-23/160	160	spring	manual	manual	HPS-2/0,7 A
RPY-2325 M-2	*157384	bench press	23	YS-23/250	250	spring	manual	manual	HPS-2/2 A
RPY-2325 EM-PYE 07	*163514	bench press	23	YS-23/250	250	spring	electric	manual	PYE-07/3/10/3M-RPY
RPES-1015 M-2	*160766	floor press	10	YS-10/150	150	spring	manual	manual	HPS-2/0,7 A
RPES-1025 EM-1	*162579	floor press	10	YS-10/250	250	spring	electric	manual	PYE-07/3/10/3M-RPY
RPES-2316 M-2	*160780	floor press	23	YS-23/160	160	spring	manual	manual	HPS-2/0,7 A
RPES-2325 M-2	*160797	floor press	23	YS-23/250	250	spring	manual	manual	HPS-2/2 A
RPES-2325 EM-PYE 07	*243728	floor press	23	YS-23/250	250	spring	electric	manual	PYE-07/3/10/3M-RPY
RPY-5015 EM	*158992	floor press	50	YH-50/150	150	hydraulic	electric	manual	PY-04/2/5/4M
RPY-5035 EM	*157575	floor press	50	YH-50/350	350	hydraulic	electric	manual	PY-04/2/5/4M
RPY-5035 EE	*157582	floor press	50	YH-50/350	350	hydraulic	electric	solenoid	PYS-07/3/10/4 E
RPY-5050 EE	*159012	floor press	50	YH-50/500	500	hydraulic	electric	solenoid	PYS-07/3/10/4 E
RPY-10035 EM	*157599	floor press	100	YH-100/350	350	hydraulic	electric	manual	PY-07/3/20/4 M-RPY
RPY-10035 EE	*157605	floor press	100	YH-100/350	350	hydraulic	electric	solenoid	PY-07/3/20/4 E
RPY-10050 EM	*157612	floor press	100	YH-100/500	500	hydraulic	electric	manual	PY-07/3/20/4 M-RPY
RPY-10050 EE	*158978	floor press	100	YH-100/500	500	hydraulic	electric	solenoid	PY-07/3/20/4 E
RPY-20035 EM	*157629	floor press	200	YH-200/350	350	hydraulic	electric	manual	PY-11/3/20/4 M-RPY
RPY-20035 EE	*157636	floor press	200	YH-200/350	350	hydraulic	electric	solenoid	PY-11/3/20/4 E
RPY-20050 EM	*157643	floor press	200	YH-200/500	500	hydraulic	electric	manual	PY-11/3/20/4 M-RPY
RPY-20050 EE	*159142	floor press	200	YH-200/500	500	hydraulic	electric	solenoid	PY-11/3/20/4 E

### Code explanation

- Valve control : M = manual pump, E = solenoid valve with pendant remote control
- Pump : M = manual pump, E = electric pump
- Piston stroke : 15 = 150 mm, 16 = 160 mm, 25 = 250 mm, 35 = 350 mm, 50 = 500 mm
- Capacity max. : 10 = 10 t, 23 = 23 t, 50 = 50 t, 100 = 100 t, 200 = 200 t
- Model

## Dimensions model RPY and model RPES

Model	RPY-10	RPY-23	RPES-10	RPES-23	RPY-50	RPY-100	RPY-200
A min., mm	-	-	50	50	280	270	320
A max., mm	440	440	930	930	1120	830	1000
B, mm	380	380	700	700	820	1000	1000
C, mm	510	510	650	650	1020	1300	1400
D, mm	-	-	500	500	1200	1480	1580
E, mm	180	180	-	-	920	860	1040
F, mm	-	-	150	150	140	140	170
G, mm	-	-	240	240	255	335	450
H, mm	840	840	1695	1695	2000	2000	2430
I, mm	300	300	245	245	315	395	550
K, mm	-	-	-	-	1000	1000	1000
L, mm	-	-	-	-	383	333	400
Weight approx., kg	77	77	94	94	450	950	2380

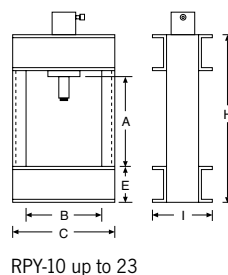
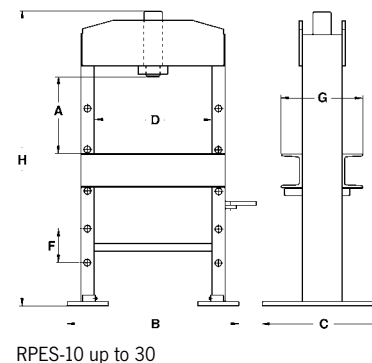
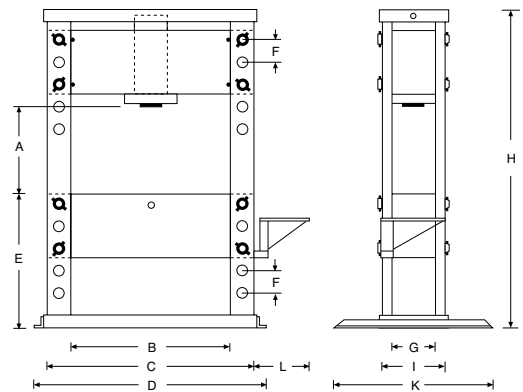

**Workshop presses are delivered ready to use.**

## Selection chart for single-acting systems

### Which hand pump is suitable for which hydraulic cylinder?

The appropriate hand pump model basically depends on the oil volume of the selected hydraulic cylinders.

To assist you in your choice please find proposals for the most common cylinders in our range.

### How to find the right hand pump in the following charts?

The chosen hydraulic cylinder can be found in the first column.

### Several hydraulic cylinders connected to one hand pump:

In those cases where several hydraulic cylinders are connected to one hand pump, the oil volume must be multiplied by the number of connected cylinders. The reservoir of the hand pump must be at least equal to the required total oil volume (plus reserve). If the reserve is very small it may be necessary to top up the reservoir after the air-bleeding procedure, depending on the length of the hydraulic hose. During further operation there is no need to consider the volume of the connected hydraulic hose (regardless of the length) because hoses always remain filled.

### Double-acting systems:

Please note that while advancing a double-acting cylinder, about 1/3 of the cylinder's oil volume flows back to the reservoir (coming from the piston chamber). After the air-bleeding procedure both oil chambers will remain filled.



**!** Please contact us for any questions regarding the configuration of complex systems according to your specific requirement.

## Selection chart for single-acting systems

Model	Oil volume cm <sup>3</sup>	Hand pumps single-stage HPS-1/0,7 A 700 cm <sup>3</sup>	Hand pumps two-stage HPS-2/0,3 A 300 cm <sup>3</sup>	Hand pumps two-stage HPS-2/0,7 A 700 cm <sup>3</sup>	Hand pumps two-stage HPS-2/2 A 2000 cm <sup>3</sup>	Hand pumps two-stage HPS-2/4 A 4000 cm <sup>3</sup>	Hand pumps two-stage HPS-2/6,5 A 6500 cm <sup>3</sup>
YS-5/15	11	+++	+++	-	-	-	-
YS-5/25	18	+++	+++	+++	-	-	-
YS-5/75	53	+++	+++	+++	-	-	-
YS-5/127	90	+++	+++	+++	-	-	-
YS-5/180	127	+++	+++	+++	-	-	-
YS-10/25	37	+++	++	+++	-	-	-
YS-10/50	73	+++	++	+++	-	-	-
YS-10/100	146	+++	++	+++	-	-	-
YS-10/150	218	+++	-	+++	-	-	-
YS-10/200	291	+++	-	+++	-	-	-
YS-10/250	363	+++	-	+++	++	-	-
YS-10/300	463	++	-	+++	+++	-	-
YS-15/25	53	+++	++	+++	-	-	-
YS-15/50	106	+++	++	+++	-	-	-
YS-15/100	213	+++	-	+++	++	-	-
YS-15/150	319	+++	-	+++	+++	-	-
YS-15/200	425	++	-	+++	+++	-	-
YS-15/250	531	++	-	+++	+++	-	-
YS-15/300	637	-	-	-	+++	-	-
YS-15/350	744	-	-	-	+++	-	-
YS-23/25	83	+++	-	+++	++	-	-
YS-23/50	166	+++	-	+++	++	-	-
YS-23/100	332	+++	-	+++	++	-	-
YS-23/160	531	++	-	+++	+++	-	-
YS-23/210	697	-	-	-	+++	-	-
YS-23/250	830	-	-	-	+++	-	-
YS-23/300	996	-	-	-	+++	-	-
YS-23/345	1145	-	-	-	+++	-	-
YS-30/125	552	++	-	+++	+++	-	-
YS-30/200	884	-	-	-	+++	-	-
YS-50/50	355	++	-	+++	+++	-	-
YS-50/100	709	-	-	-	+++	-	-
YS-50/160	1135	-	-	-	+++	-	-
YS-50/320	2269	-	-	-	-	+++	++
YS-70/150	1478	-	-	-	+++	+++	++
YS-70/330	3252	-	-	-	-	++	+++
YS-100/100	1432	-	-	-	+++	++	++
YS-100/200	2863	-	-	-	-	+++	++
YLS-10/35	51	+++	+++	+++	-	-	-
YLS-20/45	128	+++	++	+++	-	-	-
YLS-30/60	266	++	++	+++	-	-	-
YLS-50/60	426	++	-	+++	+++	-	-
YLS-100/55	788	-	-	-	+++	-	-
YFS-10/11	16	+++	+++	+++	-	-	-
YFS-20/15	31	+++	+++	+++	-	-	-
YFS-50/15	107	+++	++	+++	-	-	-
YFS-100/15	215	+++	-	+++	-	-	-
YCS-12/40	71	+++	+++	+++	-	-	-
YCS-12/75	132	+++	+++	+++	-	-	-
YCS-21/50	153	+++	++	+++	++	-	-
YCS-21/150	458	+++	-	+++	+++	-	-
YCS-33/60	287	+++	-	+++	-	-	-
YCS-33/150	716	-	-	-	+++	-	-
YCS-57/70	562	++	-	+++	+++	-	-
YCS-62/150	1330	-	-	-	+++	+++	-
YCS-93/75	990	-	-	-	+++	-	-

+++ recommended hand pump

++ these combinations can also be used, but the oil volume of the hand pump is quite small

- these combinations should not be chosen, because the oil volumes of the hand pumps are too small to fill the selected cylinder (too large and bulky, respectively)



## Selection chart for double-acting systems

Model	Oil volume cm <sup>3</sup>	Hand pumps two-stage HPH-2/0,7 A 700 cm <sup>3</sup>	Hand pumps two-stage HPH-2/2 A 2000 cm <sup>3</sup>	Hand pumps two-stage HPH-2/4 A 4000 cm <sup>3</sup>	Hand pumps two-stage HPH-2/6,5 A 6500 cm <sup>3</sup>	Hand pumps two-stage HPH-2/10 A 10000 cm <sup>3</sup>
YCH-33/150	716	++	+++	-	-	-
YCH-33/250	1200	-	+++	++	-	-
YCH-62/250	2220	-	+++	+++	-	-
YCH-93/250	3320	-	-	+++	++	-
YCH-100/40	578	+++	+++	-	-	-
YCH-140/200	4080	-	-	+++	++	-
YH-5/30	21	+++	-	-	-	-
YH-5/80	57	+++	-	-	-	-
YH-5/150	106	+++	-	-	-	-
YH-10/30	44	+++	-	-	-	-
YH-10/80	116	+++	-	-	-	-
YH-20/50	142	+++	++	-	-	-
YH-10/150	218	+++	-	-	-	-
YH-10/250	363	+++	++	-	-	-
YH-20/150	424	+++	+++	-	-	-
YH-20/250	707	++	+++	-	-	-
YH-30/200	884	-	+++	-	-	-
YH-30/350	1547	-	+++	-	-	-
YH-50/150	1064	-	+++	-	-	-
YH-50/350	2481	-	++	+++	-	-
YH-50/500	3544	-	-	+++	++	-
YH-70/150	1478	-	+++	-	-	-
YH-70/350	3449	-	-	+++	++	-
YH-100/50	716	+++	+++	-	-	-
YH-100/150	2148	-	+++	+++	-	-
YH-100/350	5010	-	-	++	+++	-
YH-100/500	7157	-	-	-	++	+++
YH-200/150	4253	-	-	+++	+++	-
YH-200/350	9924	-	-	-	++	+++
YH-200/500	14177	-	-	-	-	+++

+++ recommended hand pump

++ these combinations can also be used, but the oil volume of the hand pump is quite small

- these combinations should not be chosen, because the oil volumes of the hand pumps are too small to fill the selected cylinder (too large and bulky, respectively)





## Pump and cylinder speed chart

### Hand pumps

For hand pumps the figures given correspond to the number of pump strokes to achieve a piston travel of 10 mm.

### Power pumps

For power pumps the piston travel speed is indicated in mm/sec.

### Double-acting hydraulic cylinders

Please note that double-acting cylinders (YCH, YH and YEHA) always retract faster than they advance, due to the different oil chamber volumes.

### Reservoir volumes

The reservoir volumes of hand pumps shall at least correspond to the oil volume which is necessary to advance all connected hydraulic cylinders (plus reserve). Motor pump reservoirs should have at least twice the total required oil quantity (better 3 or 4 times) depending on the operation conditions. For continuous operation choose extra large reservoirs to avoid excessive heating-up of the hydraulic oil.

## Hand pumps

Cylinder size t	Number of pump strokes for 10 mm strokes	
	HPS-2/0,7A up to HPS-2/10A ND	HPS-1/0,7A up to HPS-2/10A HD
5	1	4
10	1	7
15	2	11
20	2	14
21	2	15
23	3	17
30	3	22
33	4	24
50	5	35
57	6	40
62	7	44
70	8	49
85	9	61
93	10	66
100	11	72
140	15	100
200	22	142
220	24	157
340	32	205
430	47	308
560	62	402
670	74	481
880	97	628

ND = Low-pressure stage (unloaded stroke)  
HD = High-pressure stage (loaded stroke)



## Power pumps

Cylinder size t	Piston travel speed in mm/sec.													
	PY-04		PY-07		PY-11		PY-22		PYE-40		PYE-55		PYE-180	
	ND	HD	ND	HD	ND	HD	ND	HD	HD	HD	HD	HD	HD	HD
5	99.9	5.4	155.9	14.2	-	-	-	-	63.8	-	-	-	-	-
10	48.7	2.6	75.9	6.9	103.5	11.5	-	-	31.1	46	69	-	-	-
15	33.3	1.8	51.9	4.7	70.8	7.9	-	-	21.2	31.5	47.2	62.9	-	-
20	25.0	1.4	39.0	3.5	53.2	5.9	106.9	12.4	15.9	23.6	35.4	47.3	75.0	-
21	23.2	1.3	36.1	3.3	49.3	5.5	99.1	11.5	14.8	21.9	32.8	43.8	69.5	-
23	21.3	1.2	33.2	3.0	45.3	5.0	91.1	10.6	13.6	20.1	30.2	40.3	63.9	-
30	16.0	0.9	24.9	2.3	34.0	3.8	68.4	7.9	10.2	15.1	22.7	30.2	48.0	-
33	14.8	0.8	23.1	2.1	31.5	3.5	63.4	7.4	9.5	14	21	28.0	44.5	-
50	10.0	0.5	15.6	1.4	21.2	2.4	42.6	4.9	6.4	9.4	14.1	18.8	29.9	-
57	8.8	0.5	13.7	1.2	18.7	2.1	37.7	4.4	5.6	8.3	12.5	16.7	26.4	-
62	8.0	0.4	12.4	1.1	17.0	1.9	34.1	4.0	5.1	7.5	11.3	15.1	24.0	-
70	7.2	0.4	11.2	1.0	15.3	1.7	30.7	3.6	4.6	6.8	10.2	13.6	21.5	-
85	5.8	0.3	9.0	0.8	12.3	1.4	24.7	2.9	3.7	5.4	8.2	10.9	17.3	-
93	5.4	0.3	8.4	0.8	11.4	1.3	22.9	2.7	3.4	5.1	7.6	10.1	16.1	-
100	4.9	0.3	7.7	0.7	10.5	1.2	21.1	2.5	3.2	4.7	7.0	9.3	14.8	-
140	3.5	0.2	5.5	0.5	7.5	0.8	15.0	1.7	2.2	3.3	5.0	6.7	10.6	-
200	2.5	0.1	3.9	0.4	5.3	0.6	10.7	1.2	1.6	2.4	3.5	4.7	7.5	-
220	2.2	0.1	3.5	0.3	4.8	0.5	9.6	1.1	1.4	2.1	3.2	4.3	6.8	-
340	-	-	2.7	0.2	3.7	0.4	7.4	0.9	1.1	1.6	2.4	3.3	5.2	-
430	-	-	1.8	0.2	2.4	0.3	4.9	0.6	0.7	1.1	1.6	2.2	3.4	-
560	-	-	1.4	0.1	1.9	0.2	3.8	0.4	0.6	0.8	1.2	1.7	2.6	-
670	-	-	1.1	0.1	1.6	0.2	3.1	0.4	0.5	0.7	1.0	1.4	2.2	-
880	-	-	0.9	0.1	1.2	0.1	2.4	0.3	0.4	0.5	0.8	1.1	1.7	-

ND = Low-pressure stage (unloaded stroke)  
 HD = High-pressure stage (loaded stroke)  
 - = combination not recommended or not possible





## Hydraulic car jack model HWH KS PROLINE

Lifting loads from 2 t up to 30 t

For lifting vehicles on one side (the lifted load must be secured mechanically with supporting stands, for example).

### Features

- Versions with hydraulic piston and mechanical spindle drive or with 2 hydraulic pistons.
- With carrying bracket from load capacity 20 t.
- Extremely low design with model HWH 2K/D (incl. 1 pressure section for lift extension).
- With integrated pressure control valve for a longer service life of the jack.
- Integrated seat valve for controlled lowering of the load.



## Technical data model HWH KS PROLINE 2 pistons

Model	Art.-No.	Capacity kg	Weight kg
HWH 2K 3,0	032301016	3000	4.87
HWH 2K 5,0	032304001	5000	6.3
HWH 2KS 10,0	032304002	10000	8.8
HWH 2KS 12,0	032307014	12000	11.0
HWH 2K NB 10,0**	032306034	10000	7.9
HWH 2K/D 10,0*	032304003	10000	6.5

\*with replaceable pressure section (height 45 mm)  
 \*\*horizontal pump unit

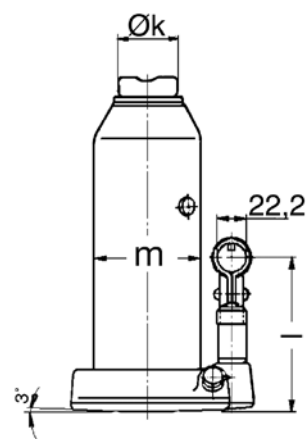

## Dimensions model HWH KS PROLINE 2 pistons

Model	HWH 2K 3,0	HWH 2K 5,0	HWH 2KS 10,0	HWH 2KS 12,0	HWH 2K NB 10,0**	HWH 2K/D 10,0*
H min., mm	185	215	200	230	175	120
H max., mm	400	520	530	570	385	230
h1, mm	110	145	130	130	104	54
h2, mm	105	160	132	125	106	56
hTr, mm	-	-	68	85	-	-
Ø k, mm	60x35	43	40	48	43	38
l, mm	115	134	116	53	136	112
m, mm	80	90	116	133	116	116
Tr, mm	-	-	32x5	40x6	-	-
Ø z1, mm	32	39	52.58	61.5	52.5	52.5
Ø z2, mm	23	29	39.5	48.5	39.5	39.5

\*with replaceable pressure section (height 45 mm)  
 \*\*horizontal pump unit

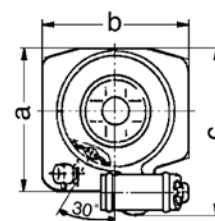
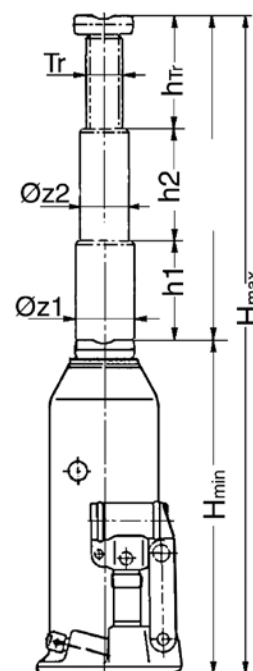

## Technical data model HWH KS PROLINE piston/spindle

Model	Art.-No.	Capacity kg	Weight kg
HWH KS 2,0	032300002	2000	2.9
HWH KS 3,5	032302004	3500	2.9
HWH KS 5,0	032303000	5000	3.9
HWH KS 8,0	032305003	8000	5.7
HWH KS 10,0	032306026	10000	5.7
HWH KS 12,0	032307006	12000	7.1
HWH KS 15,0	032308002	15000	8.3
HWH KS 20,0	032309009	20000	10.7
HWH KS 25,0	032310007	25000	13.1
HWH KS 30,0	032311003	30000	14.5

## Dimensions model HWH KS PROLINE piston/spindle

Model	HWH KS 2,0	HWH KS 3,5	HWH KS 5,0	HWH KS 8,0	HWH KS 10,0	HWH KS 12,0	HWH KS 15,0	HWH KS 20,0	HWH KS 25,0	HWH KS 30,0
H min., mm	170	170	212	220	220	230	230	240	240	240
H max., mm	377	377	462	480	480	497	495	505	515	482
h1, mm	115	115	150	150	150	157	155	155	157	142
hTr, mm	92	92	100	110	110	110	110	110	118	100
Ø k, mm	28	28	40	48	48	48	60	60	65	65
l, mm	113	113	113	116	116	116	116	116	120	116
m, mm	58	58	65	80	80	90	95	116	133	133
Tr, mm	20x4	20x4	24x5	32x5	32x5	35x6	40x6	45x6	48x6.35	48x6.35
Ø z1, mm	24.9	24.9	29.9	39.5	39.5	43.5	48.5	54.5	59.5	61.5



## Universal jacks model JH

Capacity 2 - 50 t

Universal jacks supply high forces for general operations like lifting, pushing, moving, supporting of all kind of loads.

### Features

- Robust, long life design.
- Pressure relief valve
- Precise controlled lowering.
- Additional screw extension of the piston (up to 20 t).
- Grooved saddle.
- Large base plates for increased stability.
- Model JH-50-2 with two-stage pump.
- Incl. operating lever.



JH-50-2

### Technical data model JH

Model	EAN-No. 4025092*	Capacity t	Lift mm	Additional screw extension mm	Closed height mm	Base plate mm	Pump	Weight kg
JH-2 A	*162722	2	115	50	181	90x95	1 <sup>st</sup> stage	2.7
JH-4 A	*162739	4	126	60	205	115x110	1 <sup>st</sup> stage	3.7
JH-6 A	*162746	6	130	75	219	115x110	1 <sup>st</sup> stage	4.7
JH-8 A	*162753	8	152	70	225	120x120	1 <sup>st</sup> stage	5.7
JH-12 A	*162760	12	153	80	240	140x130	1 <sup>st</sup> stage	8.0
JH-20 A	*162777	20	153	80	240	160x155	1 <sup>st</sup> stage	11.0
JH-30	*154352	30	180	-	280	210x180	1 <sup>st</sup> stage	22.0
JH-50-2	*154376	50	178	-	305	255x190	2 <sup>nd</sup> stage	53.0

## Machine jack model MH

For lifting heavy machinery and other loads.

### Features

- Can be used in every position.
- Lifting by means of a hand pump.
- Lowering by means of a precision lowering valve.
- With carrying handle for models MH 50 and MH 100.
- With carriage for model MH 250.
- Pressure control valve for a longer service life of the jack.
- Integrated lifting limitation.
- Low application height of the claw.
- Slewing claw (models MH 50 and MH 100)
- Large base plate for a high level of stability.
- Stable construction with hard-chromium plated piston rod.



### Technical data model MH

Model	Art.-No.	Capacity kg	Lift mm	Application height min. with claw mm	Application height min. with head mm	Pump lever force with full load daN	Weight kg
MH 50	040014771	5000	205	≤ 25	≤ 368	38	25
MH 100	040014772	10000	230	≤ 25	≤ 420	40	35
MH 250	040014773	25000	215	≤ 58	≤ 505	40	109

### Dimensions model MH

Model	MH 50	MH 100	MH 250
A, mm	393	449	-
B, mm	320	325	459
C, mm	213	205	420
D, mm	115	120	220
E, mm	53	55	90
G, mm	25	30	58
H, mm	368	420	505
H1, mm	573	650	720
H2, mm	205	230	215
J, mm	77	74.5	142.5
K, mm	93	108	175
L, mm	520	520	920/840
M, mm	740	745	1305/1225
N, mm	140	170	210/283
Ø Z, mm	76	91	155

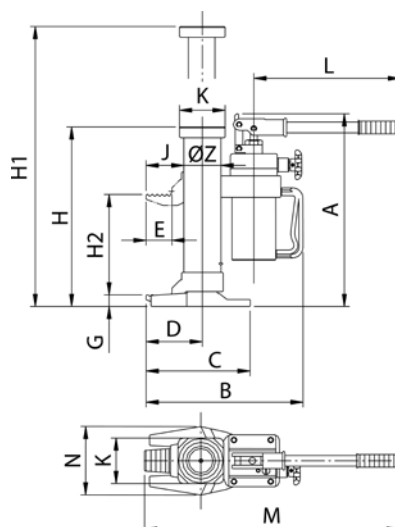



## Workshop press with hydraulic hand pump model HWPHP

Pressing power 15 - 50 t

Suitable for pressing bearings and bushes in and out, pressing and bending components, for straightening shafts and alignment work.

### Features

- Versions for 15 t and 20 t with supporting plate, prism set and centering device (accessories optional for higher tonnages).
- Fitted with 2-level hand pump.
- With manometer as standard.
- With hand cable winch for table adjustment (from model HWPHP 30).

### Technical data model HWPHP

Model	HWPHP 15	HWPHP 20	HWPHP 30	HWPHP 40	HWPHP 50
Art.-No.	040012730	040012731	040012732	040012733	040012734
Pressing power, t	15	20	30	40	50
Operating pressure, bar	240	320	250	330	330
Lifting height, mm	190	190	190	190	190
Total height A, mm	1870	1870	1920	2010	2030
Total depth B, mm	500	500	600	780	850
Total width C, mm	940	940	1260	1335	1350
Clear working width D, mm	550	550	700	775	775
Clear working height E, mm	940	940	1000	1125	1155
Table width F, mm	185	185	245	258	304
Weight, kg	160	160	250	310	420

Intended use: A workshop press/straightening press is a press with a slow closing speed of 10 mm/sec. and a maximum pressing capacity of 10 full load/full lift presses per hour.



## Accessories for workshop presses with hydraulic hand pump model HWPHP

### Technical data model HWPHP Accessories - Supporting plate

Art.-No.	suitable for workshop press	Length	Width	Bore hole diameter
		mm	mm	mm
-	15/20 t*	240	200	20/25/35
040005478	30/40 t	265	200	20/25/35
040005479	50 t	350	300	20/25/35
040005480	100 t	420	300	20/25/35

\*included in scope of delivery

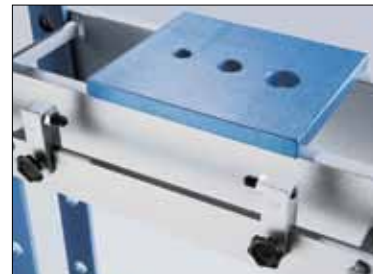

### Technical data model HWPHP Accessories - Prism set

Art.-No.	suitable for workshop press	Length	Width
		mm	mm
-	15/20 t*	195	110
040005482	30/40 t	265	140
040005483	50 t	300	160
040005484	100 t	425	240

\*included in scope of delivery



### Technical data model HWPHP Accessories - Centering device

Art.-No.	suitable for workshop press	Length
		mm
-	15/20 t*	650
040005485	30 t	650
040005486	40/50 t	900
040005487	100 t	1200

\*included in scope of delivery



### Technical data model HWPHP Accessories - Pressing pin set

Art.-No.	suitable for workshop press	Version	Diameter
			mm
040005488	15 - 40 t	6-part	12, 14, 16, 18, 20, 22
040005489	15 - 40 t	8-part	12, 14, 16, 18, 20, 22, 25, 30





## Hydraulic service jack model HRH P PROLINE

For lifting vehicles on one side (the lifted load must be secured mechanically with supporting stands, for example) and for lifting vehicles with a small ground clearance.

### Features

- Quick-lift function as standard
- Controlling, lifting and lowering via the draw bar
- Integrated pressure control valve for a longer service life of the jack.



### Technical data model HRH P PROLINE

Model	Art-No	Quick lift	Capacity kg	Height min mm	Height max mm	Dimensions max L x W x H mm	Weight kg
HRH P 1,5 H	032349002*	X	1500	98	800	1095x440x169	48
HRH P 2,0	032345006	X	2000	80	500	730x340x160	36
HRH P 2,0 L	032345005	X	2000	90	500	950x340x126	41
HRH P 3,0 H	032346028*	X	3000	130	860	1620x460x210	88
HRH P 4,0	032346001	X	4000	145	560	1270x465x200	70
HRH P 6,0	032347016	X	6000	155	570	1395x470x210	90
HRH P 8,0 H	040016051*	X	8000	180	960	1830x475x350	160
HRH P 10,0	032348004	X	10000	170	670	1700x470x280	136
HRH P 15,0	032349019	X	15000	200	600	1790x475x325	162

\*Lift-up jack

## Hydraulic service jack model HRH S SILVERLINE

For lifting vehicles on one side (the lifted load must be secured mechanically with supporting stands, for example).

### Features

- Quick-lift function as standard (except model HRH S 2,0 K)
- Model HRH S 2,0 K with handy plastic case for ease of transport.
- Integrated pressure control valve for a longer service life of the jack.
- Version L – lockable pump lever.



### Technical data model HRH S SILVERLINE

Model	Art.-No.	Quick lift	Capacity kg	Height min. mm	Height max. mm	Dimensions max. L x W x H mm	Weight kg
HRH S 2,0 K*	040008530	–	2000	125	385	532x220x140	12
HRH S 2,0 L*	040008532	X	2000	140	800	1350x430x190	75
HRH S 2,5 K**	040008531	X	2500	140	440	640x240x150	20
HRH S 3,0 L*	040008533	X	3000	125	605	1310x320x185	70
HRH S 5,0 L*	040008534	X	5000	145	560	1420x350x198	95

\*K = short; L = long

\*\*K = with additional lift extension



## Supporting stand model UB

Lifting loads 1500 - 8000 kg

For mechanical support of lifted loads and for jacking-up loads which must be held for a long period of time.

### Features

- Stamp with 5 height adjustments, locking with pin and cotter pin.
- High level of stability.

### Technical data model UB

Model	Art.-No.	Capacity kg	Height min. mm	Height max. mm	Lifting height mm	Adjusting range mm	Spread angle	Weight kg
UB 3F P 1,5	040014700	1500	260	450	190	47.5	3 x 120	4.8
UB 3F P 1,5 H**	040014701	1500	420	750	330	82.5	3 x 120	9.5
UB 3F P 3	040014702	3000	320	530	210	52.5	3 x 120	8.0
UB 3F P 5	040014703	5000	365	590	225	56.5	3 x 120	12.0
UB 3F P 5 N*	040014704	5000	235	340	105	52.5	3 x 120	8.0
UB 3F P 8	040014705	8000	360	590	230	57.5	3 x 120	18.0
UB 3F P 8 H**	040014706	8000	580	950	370	92.5	3 x 120	39.5

\*special for low-floor buses

\*\*high version



## Hydraulic repair set model HAW S

Pressing power 4000 and 10000 kg

A useful tool for repairs on car/truck bodies for quick planishing, spreading and pressing with high loads.

### Features

- Available in two versions for 4 t and 10 t.
- All parts are packed in a stable plastic case.

### Technical data model HAW

Model	Art.-No.	Pressing power kg	Cylinder stroke mm	Weight kg
HAW S 4,0	032453025	4000	127	20.5
HAW S 10,0	032457050	10000	152	34.5

## Hydraulic workshop crane model HWK KL S SILVERLINE

Capacity 500 and 1000 kg

For fitting and removing engines and for loading and unloading pallets.

### Features

- With slewing hydraulic system and sensitive lowering valve, as standard.
- With folding device for space-saving storage of the crane.
- Chassis variants: V-shaped or parallel.
- With speed increasing ratio



### Technical data model HWK KL S SILVERLINE

Model	HWK KLS 0,5	HWK KLS 0,5	HWK KLS 1,0	HWK KLS 1,0
Art.-No.	040008514	040008515	040008516	040008517
Chassis form	II	V	II	V
Capacity with crane arm length A1, kg/mm	500/1130	500/1130	1000/1130	1000/1130
Capacity with crane arm length A2, kg/mm	400/1230	400/1230	800/1230	800/1230
Capacity with crane arm length A3, kg/mm	350/1330	350/1330	700/1330	700/1330
Capacity with crane arm length A4, kg/mm	250/1430	250/1430	500/1430	500/1430
Hook height at max. outermost position B, mm	2200	2200	2200	2200
Hook height at max. innermost position C, mm	2080	2080	2080	2080
Hook height at max. outermost position E, mm	770	770	770	770
Hook height at max. innermost position D, mm	940	940	940	940
Lifting height per pump stroke with/without load, mm	20/80	20/80	20/80	20/80
Operating pressure, bar	150	150	290	290
Hand effort at WLL, daN	16	16	32	32
Drive-through height G, mm	1680	1680	1680	1680
Underclearance height M, mm	160	160	160	160
Chassis length, total H, mm	1820	1820	1820	1820
Chassis width, inside/outside I/J, mm	990/850	990/850	990/850	990/850
Weight, kg	138	132	156	150

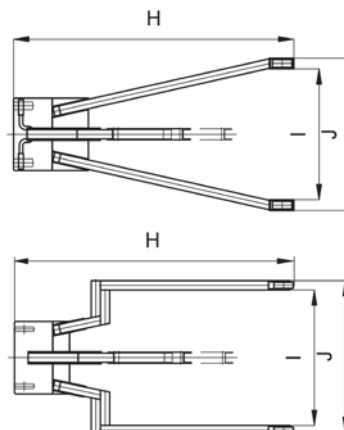
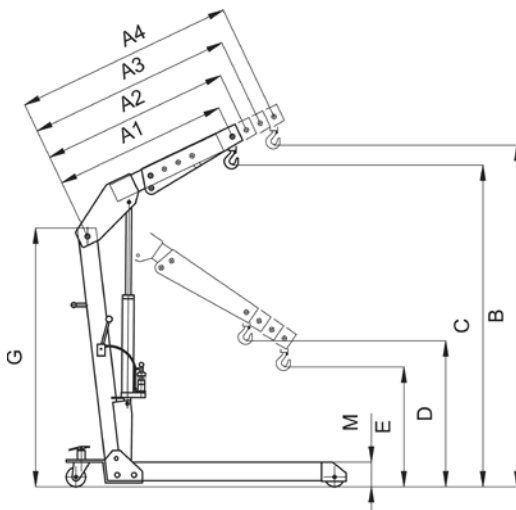

## Index

### A

Aluminium hydraulic jacks 406 - 407  
Anchor beam 278

### B

Bale grab 187  
Barrel clamp 199  
Barrel grabs 195 - 197  
Barrel rim clamp 198  
Base adaptors 366 - 367  
Block grab 184  
Board clamp 175

### C

Cable grip 97  
Cable puller 92 - 95  
Cambuckle lashing 254  
Car-Lashing 263  
Carrying case 276  
Chains 78 - 79  
Chain stop 78 - 79  
C-Hook 192 - 193  
Clamps for cable drums 206  
Clevis eye mountings 369  
Coil hook 194  
Compact aluminium rope winch 87  
Concrete pipe lifting gear 202  
Console-mounted aluminium rope winch 86  
Console-mounted rope winch 88  
Console-mounted winch 80 - 81  
Construction screw jack 130  
Container lashing 262  
Container lifting lugs 190  
Corrosion protection 42  
Crane forks 216 - 217  
Crane systems 134 - 143  
Crane weighers 218 - 219  
Crate grabs 200 - 201

### D

Detachable rope grab device 279  
Directional valves 386

### E

Edge protection profile 248, 264  
Edge protector 264  
Electric chain hoists 60 - 71  
Electric construction winch 101  
Electric hydraulic power packs 380 - 382, 384 - 385  
Electric motor pumps 378  
Electric pallet trucks 308 - 311  
Electric pedestrian stackers 318 - 322  
Electric & Pneumatic winches 101 - 121  
Elevating platform, mobile 323  
Endless winch 114 - 117  
Explosion protection 43 - 45  
Extension tubes 366 - 367

### F

Fall arrest blocks 277  
Fall arrester with rope grab 279  
Fittings, reducers, connectors 398 - 399  
Floor-mounted jib crane 136 - 138  
Foot pump 700 bar 377

### G

Girder grabs 166 - 168  
Grabs & Clamps 152 - 161, 164 - 189

### H

Hand chain hoists 22 - 41  
Hand clamp 177  
Hand pallet trucks 290 - 301  
Hand pallet trucks with weighing system 302 - 305  
Hand pumps 700 bar 372 - 375  
Hand pumps up to 2000 bar 376  
Hand stacker 312  
Harnesses 270 - 273  
Heavy load moving systems 332 - 333, 336  
Height safety kits 280 - 283  
High-tonnage cylinders 360 - 361, 364 - 365  
Hollow cylinders 352 - 355  
Horizontal lifting gear 169 - 170  
Horizontal lifting hook 171  
Hydraulic car jack 426 - 427  
Hydraulic chain cutter 414  
Hydraulic couplers 396  
Hydraulic cylinders, double-acting 354 - 361  
Hydraulic cylinders, single-acting 344 - 353, 362 - 365  
Hydraulic cylinders with safety lock nut 362 - 363  
Hydraulic hoses 397  
Hydraulic machine jacks 410 - 411  
Hydraulic oil 393  
Hydraulic propeller press system 415  
Hydraulic puller sets 404 - 405  
Hydraulic repair set 434  
Hydraulic spreader 414  
Hydraulic stage lifts 412 - 413  
Hydraulic test rig 416 - 417  
Hydraulic workshop crane 435

### I

Inside grab 189

### J

Jacks 406 - 413, 426 - 429

### K

Kit bag 276

### L

Lanyards 274 - 276  
Lifting clamps 172 - 174  
Lifting claws 366 - 367  
Lifting jack 128  
Load binders 266  
Load indicator 220 - 221  
Load moving skates 334 - 335  
Load moving systems 332 - 337  
Load-spreading plates 366 - 367  
Load stabilizer bar 264  
Low-height and flat cylinders 348 - 349

## M

Machine jack 429  
 Machine jacks with lifting claw 409  
 Manifolds 391 - 392  
 Manual claw, magnetic 176  
 Manual drive stackers 312 - 317  
 Manual winches 80 - 91  
 Mobile elevating work bench 330  
 Monorail trolley hoist 118 - 121  
 Moveable gantry crane 141

## N

Non-marring grabs 164 - 165

## P

Permanent load lifting magnets 162 - 163  
 Pipe grab 182  
 Pipe hook 205  
 Piston plates 366 - 367  
 Plate clamps 152 - 159  
 Platformlift 323  
 Pneumatic chain hoists 72 - 77  
 Pneumatic motor pumps 379  
 Polyamide kernmantle rope 279  
 Power supply 144 - 145  
 Presses 418 - 420  
 Pressure gauge adaptor 395  
 Pressure gauges 394  
 Pressure relief valves 390  
 Pressure switch 389  
 Profile steel grab 183  
 PU-coating 249  
 PU-edge protector 247  
 Pull cylinder 350 - 351  
 Puller 400 - 405  
 Pulley blocks 96  
 PU-protection sleeve 246

## R

Rack & Pinion jacks 122 - 131  
 Rail grab 188  
 Ratchet base 262  
 Ratchet jack 122  
 Ratchet lashing 255 - 261  
 Ratchet lever hoists 14 - 21  
 Round sleeve 247  
 Round sling assembly 239 - 241  
 Round slings 236 - 238  
 Round sling with duplex sleeve 236  
 Round sling with single sleeve 238  
 Roundstock grab 181

## S

Safety-check valves 388  
 Scaffold hook 276  
 Scissor elevating platform, mobile 324 - 330  
 Scissor pallet trucks 306 - 307  
 Screw clamps 178 - 180  
 Screw gate snap hook 276  
 Service jacks 432 - 433  
 Sheave block for rope guidance 89, 111  
 Slip restraining mats 265  
 Solenoid directional valves 387  
 Special lashings 262 - 263  
 Special power pack solutions 383  
 Spreader beams 208 - 215  
 Spring balancers 224 - 229  
 Spring tensioners 222 - 223  
 Steel jacks 123 - 124  
 Stone/concrete grabs 185 - 186  
 Supporting stand 434

## T

Textile lashing 254 - 261  
 Threaded flanges 368  
 Throttle-/Shut-off valves 389  
 Tilt saddles for cylinders 364 - 365  
 Tine hook 207  
 Transportation box 393  
 Trench shield clamp 204  
 Trench shield grab 203  
 Tripod 278  
 Trolleys & Trolley clamps 46 - 55  
 Truck body lifting jack 129  
 Truck lashing 262

## U

Universal cylinder 344 - 347, 356 - 358  
 Universal grab 160 - 161  
 Universal jacks 428

## V

Valves 386 - 390

## W

Wall-mounted jib crane 134 - 135  
 Wall-mounted rack 126 - 127  
 Wall-mounted winches 82 - 85  
 Webbing slings 242 - 245  
 Weld-on hooks 267  
 Wheel lashing 263  
 Winch 278  
 Workshop presses 430 - 431  
 Worm gear drive 131

## X

XL-Round sling 237































**COLUMBUS McKINNON Industrial Products GmbH**

Am Lindenkamp 31  
D-42549 Velbert  
Phone: +49 (0) 20 51/600-0  
Fax: +49 (0) 20 51/600-127  
Web Site: [www.cmco.eu](http://www.cmco.eu), [www.yale.de](http://www.yale.de)  
e-mail: [info.velbert@cmco.eu](mailto:info.velbert@cmco.eu)

**COLUMBUS McKINNON Engineered Products GmbH**

Am Silberpark 2-8  
D-86438 Kissing  
Phone: +49 (0) 82 33/21 21-800  
Fax: +49 (0) 82 33/21 21-805  
Web Site: [www.cmco.eu](http://www.cmco.eu), [www.pfaff-silberblau.com](http://www.pfaff-silberblau.com)  
e-mail: [info.kissing@cmco.eu](mailto:info.kissing@cmco.eu)

Subject to engineering changes and improvements.  
No warranty for printing errors or mistakes.  
Effective May 2011.

Reproduction or reprinting of this catalogue can  
only be carried out with written permission from  
COLUMBUS McKINNON Industrial Products GmbH.



Germany

**COLUMBUS McKINNON Industrial Products GmbH\***  
Am Lindenkamp 31  
42549 Velbert  
Phone: +49 (0) 20 51/600-0  
Web Site: www.cmco.eu, www.yale.de

**COLUMBUS McKINNON Engineered Products GmbH\***  
Am Silberpark 2-8  
36438 Kassel  
Phone: +49 (0) 82 33/21 21-800  
Web Site: www.cmco.eu, www.pfaff-silberlau.com

Austria

**COLUMBUS McKINNON Austria GmbH\***  
Gewerbepark, Wiener Straße 132a  
2511 Pfaffstätten  
Phone: +43 (0) 22 52/46066-0  
Web Site: www.cmco.at, www.yale.at

Switzerland

**COLUMBUS McKINNON Switzerland AG**  
Dalkenstrasse 25  
8107 BUCHS/ZH  
Phone: +41 (0) 44 8 51 55 77  
Web Site: www.cmco.ch

Italy

**COLUMBUS McKINNON Italia srl**  
Via Picasso, 32  
20025 Legnano (MI)  
Phone: +39 (0) 331/57 63 29  
Web Site: www.cmco.eu

Netherlands

**COLUMBUS McKINNON Benelux B.V.\***  
Grootmoord 30  
3341 LT Hendrik Ido Ambacht  
Phone: +31 (0) 78/6 82 59 67  
Web Site: www.yalestakeholders.nl

France

**COLUMBUS McKINNON France SARL\***  
Zone Industrielle des Forges  
18108 Verzon Cedex  
Phone: +33 (0) 245/71 85 70  
Web Site: www.cmco-france.com

United Kingdom

**Yale Industrial Products**  
A trading division of  
**COLUMBUS McKINNON Corporation Ltd.\***  
Knuttsford Way, Sealand Industrial Estate  
Chester CH1 4NZ  
Phone: +44 (0) 1244 375375  
Web Site: www.yaleproducts.com

**Yale Industrial Products (Northern Ireland)**

A trading division of  
**COLUMBUS McKINNON Corporation Ltd.\***  
Unit 1A, The Ferguson Centre  
57-59 Manse Road, Newtownabbey, BT36 6RW  
Phone: +44 (0) 2890 840697  
Web Site: www.yaleproducts.com

Spain and Portugal

**COLUMBUS McKINNON Ibérica S.L.U.**  
Ctra. de la Escuela, 21 acc. 4  
41011 Sevilla  
Phone: +34 954 29 89 40  
Web Site: www.yaleiberica.com

**COLUMBUS McKINNON Ibérica S.L.U.**

Rua Posedon, 2 (Polg. Icnal)  
15179 Penillo-Oleiros (A Coruña)  
Phone: +34 981 6395 91  
Web Site: www.yaleiberica.com

**COLUMBUS McKINNON Ibérica S.L.U.**

Polg. Ind. Empresarium  
Calle Retama, no 25 - Nave B-19  
50720 Zaragoza  
Phone: +34 876 26 26 75  
Web Site: www.yaleiberica.com

Poland

**COLUMBUS McKINNON Polska Sp.z o.o.**  
Ul. Owsiana 14  
62-064 Pleszka  
Phone: +48 (0) 61 656 66 22  
Web Site: www.pfaff.info.pl

Hungary

**COLUMBUS McKINNON Hungary Kft.**  
Vasárhegyi út 5, VI ép  
8000 Szekesfehervar  
Phone: +36 (22) 546-720  
Web Site: www.yale.de

South Africa

**COLUMBUS McKINNON Corporation (Pty) Ltd.\***  
P.O. Box 15557  
Westmead, 3608  
Phone: +27 (0) 31/700 4388  
Web Site: www.cmworks.co.za

**Yale Engineering Products (Pty) Ltd.**

12 Laser Park Square, 34 Zeiza Rd.  
Laser Park Industrial Area, Honeydew  
Phone: +27 (0) 11/794 29 10  
Web Site: www.yalepb.co.za

**Yale Lifting & Mining Products (Pty) Ltd.**

P.O. Box 592  
Maggiesburg, 1791  
Phone: +27 (0) 14/577 2607  
Web Site: www.yale.co.za

Russia

**COLUMBUS McKINNON Russia LLC**  
Chemicheskii Pereulok, 1, Lit. AB  
Building 72, Office 33  
198095 St. Petersburg  
Phone: +7 (812) 322 68 38  
Web Site: www.yale.de

China

**Hangzhou LILA Lifting and Lashing Co. Ltd.\***  
Nanhuan Road, Zhejiang Hi-tech Park  
Hangzhou High-tech Industry Development Zone  
Zhejiang Province  
Phone: +86 10 85 23 63 86  
Web Site: www.yale-cn.com

**COLUMBUS McKINNON (Hangzhou) Industrial Products Co. Ltd.\***

Xiaoshan, Yuyao, Zhejiang Province  
Postcode 311296  
Phone: +86 10 85 23 63 86  
Web Site: www.yale-cn.com

**Pfaff-silberblau China**

3350 Nanhuan Rd., Zhiwang Industrial Park  
Hangzhou Hi-tech Zone  
Zhejiang Province, 310053  
Phone: +86 57 18 77 58 548  
Web Site: www.pfaff-silberblau.com

Thailand

**Yale Industrial Products Asia Co. Ltd.\***  
525 Raj-u-thit Road  
Hatyai, Songkhla 90110  
Phone: +66 (0) 74 25 27 62  
Web Site: www.yale-thailand.com