

Yale

new!



Yale **ERGO 360[®] UT**
Utility!

Catalogue No. 4
10/2021

CMS
COLUMBUS MCKINNON

Yale®

Yale is the leading brand for standard manual hoisting equipment in Europe. As early as 1877, Yale produced the first spur-gear hand chain hoist incorporating the Weston screw-and-disc type load brake – a design principle which is still used today. In 1936, hoist manufacture started in Velbert with the production of the world renowned PUL-LIFT®.

The products, which are delivered ready for operation, are used world-wide for the most varied industrial and commercial applications: in construction, (mechanical) engineering, transportation, energy & water management, oil & gas and paper industries.

The product range as well as all new and further developments of Yale in the individual product sectors constantly raise the benchmark for quality, reliability and safety.



The logo for Pfaff-silberblau, featuring the word 'PFAFF' in a stylized blue font with a white outline, and 'silberblau' in a smaller, lowercase blue font below it. To the right of the text is a blue and white graphic element consisting of two parallel slanted bars.

Pfaff-silberblau (Columbus McKinnon Engineered Products) has been a technology leader in components and system solutions for mechanical drive and lifting technology for 150 years.

The portfolio ranges from high-quality screw jacks, innovative linear drives, lifting columns, screw drives, bevel gears to high-performance lifting tables and cable winches including accessories.

Based on these components, customer-specific solutions for a wide variety of applications are possible.

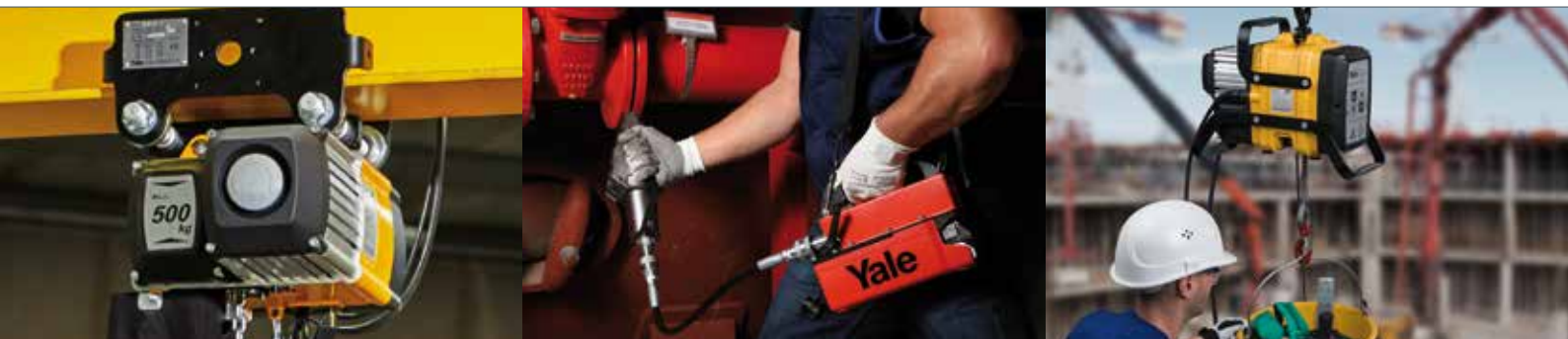

The comprehensive range of products includes hoists and cranes, balancers, load hoisting tackles and crane weighers, textile lifting and lashing equipment, material handling equipment and load moving systems, hydraulic tools as well as workshop equipment.

Pfaff Verkehrstechnik GmbH is a sister company of Columbus McKinnon Engineered Products GmbH.

In addition to the delivery of traffic engineering components, the company primarily offers complete project planning, installation and maintenance of turnkey lifting systems for rail vehicles, which are used worldwide. The portfolio includes lifting jacks, underfloor lifting systems, roof work platforms for trains and electric buses as well as all workshop equipment.

www.yale.de

www.pfaff-silberblau.com



Columbus McKinnon designs and produces an extensive portfolio of durable and reliable products for a wide range of industries, with which heavy loads can be moved, lifted, positioned and secured ergonomically and safely.

With a history spanning over 150 years, Columbus McKinnon is a global leader in lifting and smart technology.

Our portfolio of high quality brands as Yale, Pfaff-silberblau, Stahl CraneSystems, CM, Tigrip, Magnetek, Duff-Norton und Coffing Hoists are solving high value problems that transform businesses, increase safety and drive business growth and efficiency.

At Columbus McKinnon, we work together, guided by our mission, vision, and values, to raise expectations of ourselves and ultimately increase our value to the customers and shareholders we serve.

Our Mission

We provide expert, professional-grade solutions and products, to help solve our customers' high-value problems.

Our Vision

To become the leading industrial technology company in safe and productive motion control.



Experience, know-how and innovative strength combined with a far-reaching understanding of user requirements is the formula for success on which our portfolio of hoisting and material handling equipment products has been based for a long time.

Our tradition of close customer relationships and customer services as well as our constant striving for optimisation provide the basis for all new and further developments of the Yale and Pfaff-silberblau brands.

Columbus McKinnon is a global organization with headquarter in Buffalo, New York. Columbus McKinnon's global footprint includes offices and manufacturing facilities across North America, Latin America, Europe, Africa and Asia.

Columbus McKinnon Corporation
Corporate Headquarters
 205 Crosspoint Parkway
 Getzville, New York 14068

www.columbusmckinnon.com



Training

As a manufacturer, we have many years of experience in inspecting and repairing products in the field of lifting technology. We would like to pass on this knowledge to our customers and offer seminars in our training centre in Wuppertal seminars for “qualified person” in accordance with DGUV regulation 54 for winches, lifting and pulling equipment.

These are not only product training courses, but seminars that provide participants with up-to-date insider information and a solid knowledge of the handling of rope, lifting and slinging technology.

The most modern communication techniques, a portion of practice and optimally designed seminar materials guarantee a quick and lasting seminar success.



INFO

All seminars can also be held in-house if required.

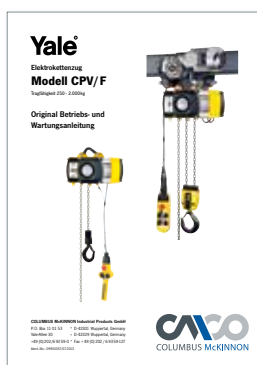

Certified security

You are in safe hands - Every unit is supplied with operating instructions, CE declaration of conformity resp. manufactures works test certificate, which confirms the perfect tested status of the product.

Additional documentation, e.g. spare parts manuals or maintenance and repair instructions are available on request or at our homepage.

www.yale.de

Offering advice

Our qualified personnel are there for you around the globe at all our locations, as well as specialised dealers who provide competent know-how and service.

Business hours:

Monday - Thursday 08:00 a.m. - 04:30 p.m.

Friday 08:00 a.m. - 03:30 p.m.

Shipping:

Monday - Thursday 06:30 a.m. - 04:30 p.m.

Friday 06:30 a.m. - 03:00 p.m.



EN ISO 9001

Columbus McKinnon Industrial Products GmbH manufactures world wide according to uniform, controlled standards of EN ISO 9001. This is a guarantee for our business partners that given standards in design and development, manufacturing, assembly and service are complied with.



Special documentation

Further inspections in form of 2.2 or 3.1 certificates according to EN 10204, GOST R certificates or specific pre-shipment inspections e.g. by DNV or GL can be carried out at cost on request.





Hoisting Equipment

- Ratchet lever hoists
- Hand chain hoists
- Corrosion protection
- Trolleys & Trolley clamps
- Electric & Pneumatic chain hoists
- Chains & Accessories
- Manual winches
- Cable puller & Accessories
- Electric winches
- Rack & Pinion jacks

Crane Systems

- Wall-mounted jib cranes
- Floor-mounted jib cranes
- Moveable gantry cranes

Power supply



Tigrip® Load Hoisting Tackle

- Grabs & Clamps
- Permanent load lifting magnets
- Lifting lugs & C-hooks
- Barrel grabs & Crate grabs
- Load hoisting tackle for underground construction
- Clamps & Tine hooks
- Spreader beams
- Crane forks

Tigrip® Crane Weighers

- Crane weighers
- Load indicator

Spring Balancers

- Spring tensioners
- Spring balancers

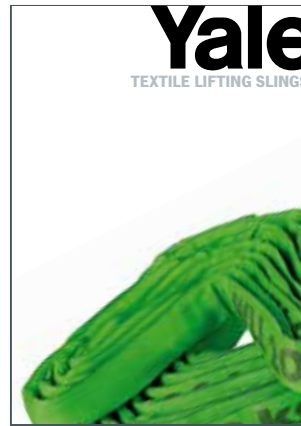

Textile Lifting Slings

- Round slings
- Round sling assembly
- Webbing slings

Lashing Systems

- Lashings
- Special lashings



Material Handling Equipment

- Hand pallet trucks
- Hand pallet trucks with weighing system
- Scissor pallet trucks
- Pallet lift trucks
- Manual drive stackers
- Electric pedestrian stackers
- Elevating platforms

Load Moving Systems

INFO

Information about ATEX products and explosion protection can be found in our ATEX catalogue.

Please contact us for further information!

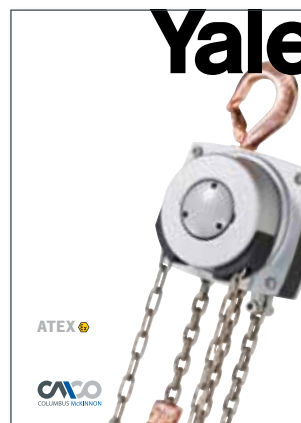

ATEX

- Pneumatic chain hoists
- Hand chain hoists
- Trolleys
- Rack & Pinion jacks
- Ratchet lever hoists

More products like
Electric & manual winches,
Sheave blocks and
Electric chain hoists
on request



Hydraulic Jacks & Tools

Hydraulic cylinders, single-acting
 Hydraulic cylinders, double-acting
 Hand pumps 700 bar
 Hand pumps up to 2000 bar
 Foot pump 700 bar
 Electric & Pneumatic motorpumps
 Electric hydraulic power packs
 Hydraulic valves & Accessories
 Hydraulic puller & Jacks
 Hydraulic jacks & Tools
 Test rig for hoisting equipment
 Workshop presses



Workshop Equipment

Jacks
 Workshop presses & Accessories
 Service jacks
 Supporting stand
 Hydraulic repair set

INFO

Please note our user instructions at the beginning of each chapter.

Table of contents

| | Page |
|-----------------------------|-----------|
| Hoisting Equipment | 8 - 135 |
| Crane Systems | 136 - 145 |
| Power Supply | 146 - 147 |
| <hr/> | |
| Tigrip® | |
| Load Hoisting Tackle | 148 - 213 |
| Crane Weighers | 214 - 219 |
| <hr/> | |
| Spring Balancers | 220 - 227 |
| <hr/> | |
| Textile Lifting Slings | 228 - 250 |
| Lashing Systems | 251 - 267 |
| <hr/> | |
| Material Handling Equipment | 268 - 321 |
| Load Moving Systems | 322 - 327 |
| <hr/> | |
| Hydraulic Jacks & Tools | 328 - 419 |
| <hr/> | |
| Workshop Equipment | 420 - 433 |
| <hr/> | |
| Returns | 434 |

Hoisting Equipment

Yale and Pfaff-silberblau hoisting equipment products are reliable and proven equipment renowned world-wide for applications in industry, trade and services.

The comprehensive range includes manual and powered hoisting equipment for a safe lifting and handling of loads ranging from 125 kg to 50000 kg. The products feature a long service life as well as easy and quick maintenance or repair.

Yale and Pfaff-silberblau hoisting equipment products comply with national and international regulations such as the EC Machinery Directive 2006/42/EC and corresponding supplements. In order to meet our high quality standard, the devices are subjected to an overload test in the factory and provided with a test certificate and operating instructions with a declaration of conformity or a manufacturer's declaration.

INFO

Please note our user instructions at the beginning of each chapter.

Table of contents

| | Page |
|-----------------------------------|-----------|
| Ratchet lever hoists | 14 - 30 |
| Hand chain hoists | 31 - 47 |
| Corrosion protection | 48 - 51 |
| Trolleys & Trolley clamps | 52 - 59 |
| Electric & Pneumatic chain hoists | 60 - 81 |
| Chains & Accessories | 82 - 84 |
| Manual winches | 85 - 95 |
| Cable puller & Accessories | 96 - 101 |
| Electric winches & Accessories | 102 - 113 |
| Rack & Pinion jacks | 114 - 135 |
| Crane Systems | 136 - 145 |
| Power supply | 146 - 147 |

Yale

HOISTING EQUIPMENT



INFO

This user information presents a general review regarding the operation of hoisting equipment and does not substitute the existing operating instructions for the specific hoist product.

Lifting operations with hoisting equipment may be carried out by competent users (trained in theory and practice) only.

When operated correctly, our hoist products will offer the highest degree of safety in line with long life expectancy and avoid damage to the product and people.

Modification of delivery condition

Design and construction of the hoist may not be altered, e.g. by installation of outside supplied parts, bending, welding, grinding, removal of safety relevant components like locking devices, locking pins, safety latches etc.

Limitations of operation

Loading

Our hoists have been designed for lifting and transporting of loads. Some models (e.g. ratchet lever hoists) may also be used for pulling and lashing purposes, if admitted in the operating instructions. The indicated capacities refer to loading in straight line and must not be exceeded. Lifting media (e.g. lifting chain or rope) must not be slung over edges and must not be used for the attachment of the load.

Temperature

Hoists may normally be operated at ambient temperatures between $-10\text{ }^{\circ}\text{C}$ up to $+50\text{ }^{\circ}\text{C}$.

These values are approximate and may deviate from the specific givings of the hoist product. The accurate data are given in the current operating instructions. Special models are available on request for higher or lower temperature ranges.

Attention: At temperatures below $0\text{ }^{\circ}\text{C}$ the brake should be checked for freezing. (Check lifting function prior to starting work and refer to "Inspection prior to initial operation").

Shock loading

The indicated capacities are based on shock-free loading of the hoist. Light bumps as occurred during lifting and lowering as well as transporting of load are admitted. Heavier shock loadings, e.g. falling of the load, are strictly forbidden.

Chemicals

Hoists and attachments may not be operated without hesitation in the area of chemicals or chemical vapours – consult our specialists for advice. Hoists which have been subject to chemicals or vapours must be taken out of service and inspected by us.

Transport of people

Transport of people with hoisting equipment is generally forbidden! Transport of people may only be carried out with specially authorized products (e.g. Yaletrac, Mtrac).

Operation in danger zones

Lifting or transport of loads must be avoided while personnel are in the danger zone.

People are not allowed to pass over or under a suspended load.

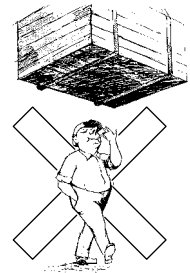

Electrical hazards

Load carrying hoist components (e.g. load chain) must not be subject to electric current and must never be used as a ground connection during welding. Further electrical hazards, e.g. with powered hoists, are indicated in the specific operating instructions!

Electric connections may only be performed by authorized persons resp. companies.

INFO

For information on training please see page 4.

Application advices

- Hoists must always be in perfect condition and provided with a legible identity plate.
- Prior to starting work, the hoist including load carrying devices, equipment, supporting structure and suspension must be inspected for obvious deficiencies and failures. In addition, the function of the brake and the correct attachment of hoist and load have to be checked by carrying out a short work cycle of lifting/pulling or tensioning and releasing.
- Inspect the load chain for sufficient lubrication and visually check for external defects, deformations, superficial cracks, wear or corrosion marks. A defective chain must be replaced prior to operation of the hoist.



- Units equipped with two chain falls should be inspected for twisted or kinked chains prior to being put into operation. The chains of multiple fall hoists may be twisted if the bottom block was turned over.
- Inspect top and bottom hooks for deformations, damage, cracks, wear or corrosion marks. A safety latch must be available and work effectively.
- Hoists with obvious defects and units which have been subject to overload or other dangerous influences have to be taken out of service and may only be operated after test and repair if so required.
- When selecting the proper product, make sure that the hoist is suitable to accept transportation, suspension, type of lashing devices and lashing points safely and without unintended movement (e.g. slipping).
- Load chains must not be used in kinked or knotted condition.

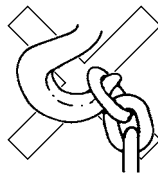

- The load must always be seated in the saddle of the hook. Never attach the load on the tip of the hook. This applies to top and bottom hooks.
- The operator must ensure that the load is attached in a manner that does not expose himself or other personnel to danger by the hoist, chain(s) or the load.
- During lifting operations the load and suspension hook of the hoist must be perpendicular to the load center to prevent pendle motion of the load.
- The operator may start moving the load only after it has been attached correctly and all personnel are off the danger zone.

- Before lifting make sure that the load can move freely.
- After lifting or tensioning, a load must not be left unattended for a longer period of time.
- Chain stops, slipping clutches etc. are overload protection devices and may not be used as regular load limiters.
- Do not throw the hoist down. Always place it properly on the ground.

Labelling (Example)

Serial or model number

Chain dimension and design (Grade) of load chain

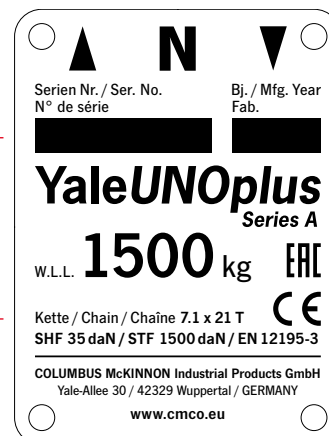

Year of manufacture

Rated capacity

Load securing

Manufacturer or supplier





Maintenance and repair

- To ensure safe operation, all hoisting equipment must be subjected to regular inspections according to the maintenance instructions given by the manufacturer.
- Hoists which are due for maintenance (normally once per year, unless adverse working conditions dictate shorter periods) or products with obvious defects may be returned to us for inspection and repair.
- Inspections and tests must be performed by competent persons or specialist workshops that use original spare parts.

Inspections

- According to German laws and standards all hoisting equipment must be subjected to a mandatory inspection at least once a year. The inspection must be performed by a competent person.
- On building sites hoists have to be inspected every time before operation.
- Hoist and supporting components have to be cleaned prior to inspection. The cleaning procedure must not cause chemical damages (e.g. no acid-embrittlement). Do not expose the hoist and supporting components to unallowed temperatures by e.g. flame cleaning avoid concealment of cracks and excessive material loss (sand blasting).
We shall be pleased to consult you in this respect. Please submit your hoists for inspection in clean condition. This will reduce inspection costs considerably.

Criteria for hoist disposal

Hoists must no longer be operated if e.g.:

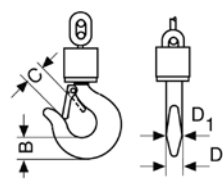
- The identification (identity plate) is missing or illegible.
- Security relevant components like brake, slipping clutch, ratchet pawls etc. do not properly function any longer.
- Housing, control units and suspension of the hoist present obvious deficiencies, i.e.
 - cuts, grooves, cracks
 - excessive corrosion
 - staining due to heat
 - signs of subsequent welding resp. spatters which cannot be easily removed and leave stains.
- Ropes show breakage of wires resp. bruises (criteria for disposal of ropes are given in classification DIN 15020), damages to the rope sleeve and similar failures.
- The load chain presents twisted or distorted links or shows an elongation of 5% of one chain link or a reduction in diameter of more than 10% (average of two measurings (longitudinal and transverse) compared to the nominal diameter).
- The opening (C) of suspension and/or load hooks is stretched by more than 10% compared with the nominal dimension, or if the hook mouth shows a wear of more than 5% of either dimension B or D.
 
- Detrimental impacts by e.g. overloading, shock loading, chemical influences or heat have occurred, the hoist may only be returned to service after careful inspection and repair.





C 85 Ratchet lever hoist with roller chain

Capacity 750 - 3000 kg

D 85 Ratchet lever hoist with link chain

Capacity 750 - 10000 kg

Almost unlimited applications in maintenance, mining, construction, steel fabrication, shipbuilding and utility work. Ideal for moving and positioning heavy machines and securing heavy loads, simplifies setting pipes etc. in manholes and trenches.

Features

- Enclosed housing with housing cover, handlever and bottom block made from high tensile white malleable cast iron for overall rugged construction.
- Wet painting colour code RAL 1023.
- The graphite cast iron load sheave for the link chain has precision machined chain pockets for accurate fit and durability of the load chain.
- The roller chain sprocket is made from heat treated chromium-molybdenum steel with precision machined teeth to ensure smooth chain movement.
- Alloyed steel link chain with zinc-plated, in accordance with national and international standards and regulations.

Options

- Except for the capacity 10 t, all units can be equipped with an overload protection (slip clutch). This slip clutch is activated at $25\% \pm 15\%$ overload, lifting of the load is no longer possible.

INFO

Since 1936, the Velbert factory has built over 1 million units.



All ratchet lever hoists with a capacity exceeding 750 kg can be used for load attachment according to EN 12195.

Yale hoists and trolleys are not designed for passenger elevation applications and must not be used for this purpose.



We are pleased to send you our new Atex catalogue in PDF format.

Technical data C 85

| Model | Art.-No. | Capacity kg | Number of chain falls | Chain dimensions p x b ₁ | Chain dimensions p x b ₁ | Lift with one full lever turn mm | Handle pull at WLL daN | Weight at standard lift (1.5 m) kg |
|------------------|-----------|----------------|--------------------------|---|--|---|------------------------------|---|
| | | | |  inch |  mm | | | |
| ZUGHUB C 85 750 | N01141295 | 750 | 1 | 5/8" x 3/8" | 15.875 x 9.65 | 115 | 38 | 8.7 |
| ZUGHUB C 85 1500 | N01141296 | 1500 | 1 | 1" x 1/2" | 25.4 x 12.7 | 45 | 31 | 17.0 |
| ZUGHUB C 85 3000 | N01141297 | 3000 | 1 | 1 1/4" x 5/8" | 31.75 x 15.875 | 36 | 40 | 22.2 |

Dimensions C 85

| Model | ZUGHUB C 85 750 | ZUGHUB C 85 1500 | ZUGHUB C 85 3000 |
|------------|--------------------|---------------------|---------------------|
| A min., mm | 322 | 389 | 403 |
| B, mm | 21 | 27 | 35 |
| C, mm | 27 | 30 | 34 |
| D, mm | 15 | 20 | 25 |
| D1, mm | 17 | 23 | 25 |
| E, mm | 443 | 443 | 570 |
| F, mm | 112 | 189 | 197 |
| G, mm | 56 | 134 | 142 |
| H, mm | 56 | 55 | 55 |
| J, mm | 142 | 171 | 179 |
| K, mm | 39 | 72 | 76 |
| L, mm | 103 | 99 | 103 |

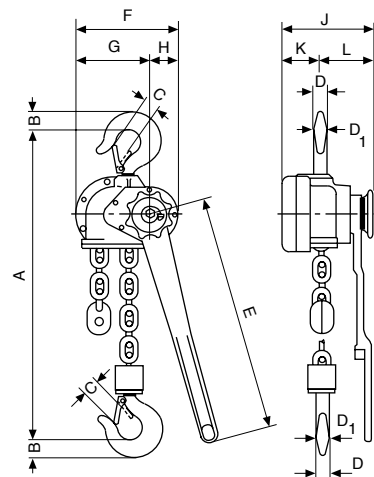

Technical data D 85

| Model | Art.-No. | Capacity kg | Number of chain falls | Chain dimensions d x p in mm/ design | Lift with one full lever turn mm | Handle pull at WLL daN | Weight at standard lift (1.5 m) kg |
|-------------------|-----------|----------------|--------------------------|---|---|------------------------------|---|
| | | | | | | | |
| ZUGHUB D 85 750 | N01541291 | 750 | 1 | 6 x 18.5 - T | 111 | 38 | 8.2 |
| ZUGHUB D 85 1500 | N01541292 | 1500 | 1 | 9 x 27 - T | 45 | 31 | 16.3 |
| ZUGHUB D 85 3000 | N01541293 | 3000 | 1 | 11 x 31 - T | 33 | 40 | 19.6 |
| ZUGHUB D 85 6000 | N01541294 | 6000 | 2 | 11 x 31 - T | 17 | 42 | 32.9 |
| ZUGHUB D 85 10000 | N01541511 | 10000 | 3 | 11 x 31 - T | 11 | 37 | 60.0 |

Dimensions D 85

| Model | ZUGHUB D 85 750 | ZUGHUB D 85 1500 | ZUGHUB D 85 3000 | ZUGHUB D 85 6000 | ZUGHUB D 85 10000 |
|------------|--------------------|---------------------|---------------------|---------------------|----------------------|
| A min., mm | 322 | 389 | 403 | 532 | 805 |
| B, mm | 21 | 27 | 35 | 48 | 61 |
| C, mm | 27 | 30 | 34 | 46 | 54 |
| D, mm | 15 | 20 | 25 | 40 | 40 |
| D1, mm | 17 | 23 | 25 | 40 | 45 |
| E, mm | 443 | 443 | 570 | 570 | 570 |
| F, mm | 112 | 189 | 197 | 197 | 305 |
| G, mm | 56 | 134 | 142 | 142 | 163 |
| H, mm | 56 | 55 | 55 | 55 | 142 |
| J, mm | 142 | 171 | 179 | 218 | 218 |
| K, mm | 39 | 72 | 76 | 76 | 76 |
| L, mm | 103 | 99 | 103 | 142 | 142 |



Option:
Overload protection
for C/D 85.



Yale *ERGO 360*[®]

Ratchet lever hoist

Capacity 750 - 9000 kg

Redefining lever-operated hoists, the Yale *ERGO 360*[®] features the revolutionary crank handle that allows for efficient operation in both lifting and pulling applications. Ergonomically designed for increased safety, the patented Yale *ERGO 360*[®] lets the operator work up to 12 times faster and with as much as 30% less pull force than with conventional ratchet lever tools.

Features

- The lightweight, high-strength aluminium housing with powder coating and high-quality bearings offer a long service life even with intensive use and rough operating conditions.
- The hand lever with integrated snap crank ensures ideal power transmission and enables a 360° working range. This increases productivity and reduces the risk of injury.
- Display of the operating direction or free chaining in the viewing window of the hand lever.
- The covered load pressure brake remains free of dirt and moisture, which enables precise load positioning.
- Standard free chaining device to quickly attach the load or to pull the chain through the hoist in both directions.
- Chain guide and stripper are made of robust cast iron and zinc plated to protect against corrosion.
- Alloyed steel link chain with zinc-plated resp. yellow chromated finish, in accordance with national and international standards and regulations.
- Rotatable, forged top and load hooks and casted safety latches provide reliable and safe load suspension. The screwed top hook cross bars and bottom blocks are allowed for easy maintenance.

Options

- All Yale *ERGO 360*[®] units can be equipped with an overload protection device in the form of a slip clutch which is factory preset to approx. 25% ± 15% overload.
- Shipyard hooks available for 1500 kg and 3000 kg units.



PATENTED
**HAND LEVER WITH
 RETRACTABLE CRANK**
 DESIGNED FOR OPTIMAL
 EFFICIENCY & SAFETY



Capacity
750 kg

Shortest hook space
 (A min.) 320 mm
 Handle pull at WLL
 crank lever handle operation
 20 daN
 Weight 6.7 kg



Capacity
1500 kg

Shortest hook space
 (A min.) 375 mm
 Handle pull at WLL
 crank lever handle operation
 24 daN
 Weight 9.6 kg



Capacity
3000 kg

Shortest hook space
 (A min.) 445 mm
 Handle pull at WLL
 crank lever handle operation
 35 daN
 Weight 17.2 kg



Capacity
6000 kg

Shortest hook space
 (A min.) 563 mm
 Handle pull at WLL
 crank lever handle operation
 37 daN
 Weight 28.9 kg



Capacity
9000 kg

Shortest hook space
 (A min.) 695 mm
 Handle pull at WLL
 crank lever handle operation
 41 daN
 Weight 49.5 kg



When folded out, the lever handle can serve as a carrying grip for easy transport. Simply attach the end stop to the hook and slip the hook onto the crank handle.



Unique body design allows the YaleERGO 360® to lay flat to minimize tipping or slipping during operation.



The YaleERGO 360® in conventional use.

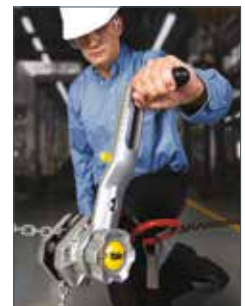

The YaleERGO 360® in use of the extended crank handle.

(((DISTINCTIVE CLICKING SOUND))) ENSURES THE HANDLE IS LOCKED INTO POSITION

To return handle to upright position, simply pull the handle outward and snap into place inside the lever.

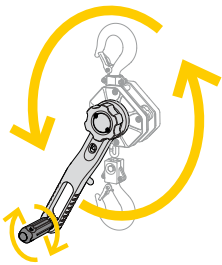
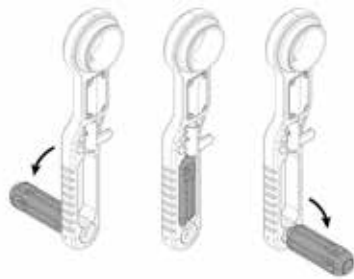

The hand lever with integrated crank

- 360° rotation increases efficiency, allowing operators to work up to 12 times faster than with a conventional ratchet lever hoist.
- Requires 30% less pull force to operate.
- Easy and effective operation from any angle with handle that folds down and locks into position on either side of the lever.
- Design keeps the operator's body aligned with the load chain, reducing the risk of the twist effect – when a hoist twists around the chain. No need to use a second hand to stabilize the hoist.
- Operator can securely grip the grooved, no-slip handle.
- Crank handle made of durable polyamide with a heavy-duty steel core for rugged use.



SAFE & SECURE

SELECTOR LEVER LOCKS IN PLACE TO PREVENT ACCIDENTALLY SWITCHING.

Pull down on the selector lever to unlock it, turn it to the desired direction, and release it into the locking position.

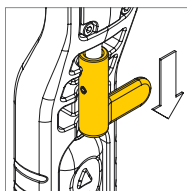

Convenient directional indicator

Easy-to-use, highly visible directional indicator window located in the handle clearly shows the operating direction as LIFTING (▲), LOWERING (▼) or NEUTRAL (N).

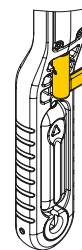
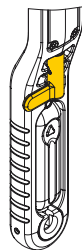

Simple & smooth free chaining device

Quick positioning of the unloaded chain - even with one-handed operation.

In this operating mode, the chain can be pulled through the unit by hand in both directions in order to attach it more quickly.

The free chaining device is activated by moving (shifting) the lever to the neutral position (N).

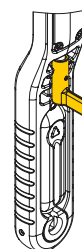

Technical data YaleERGO 360®

| Model | Art.-No. | Capacity kg | Number of chain falls | Chain dimensions d x p in mm/ design | Lift with one full lever turn mm | Handle pull at WLL daN | Handle pull at WLL with crank daN | Weight at standard lift (1.5 m) kg |
|-------------------|-----------|----------------|--------------------------|---|---|------------------------------|--|---|
| YaleERGO 360 750 | 192028204 | 750 | 1 | 5.6 x 17.1 - T | 27.2 | 21 | 20 | 6.7 |
| YaleERGO 360 1500 | 192028202 | 1500 | 1 | 7.1 x 21 - T | 21.7 | 31 | 24 | 9.6 |
| YaleERGO 360 3000 | 192028553 | 3000 | 1 | 10 x 28 - V | 20.1 | 43 | 35 | 17.2 |
| YaleERGO 360 6000 | 192035451 | 6000 | 2 | 10 x 28 - V | 10.1 | 46 | 37 | 28.9 |
| YaleERGO 360 9000 | 192039362 | 9000 | 3 | 10 x 28 - V | 6.7 | 50 | 41 | 49.5 |

Dimensions YaleERGO 360®

| Model | YaleERGO 360 750 | YaleERGO 360 1500 | YaleERGO 360 3000 | YaleERGO 360 6000 | YaleERGO 360 9000 |
|------------|---------------------|----------------------|----------------------|----------------------|----------------------|
| A min., mm | 320 | 375 | 445 | 563 | 695 |
| B, mm | 20 | 26 | 37 | 45 | 68 |
| C, mm | 27 | 31 | 40 | 47 | 68 |
| D, mm | 18 | 21 | 28 | 35 | 50 |
| E, mm | 327 | 327 | 377 | 377 | 377 |
| F, mm | 300 | 300 | 350 | 350 | 350 |
| G, mm | 40 | 51 | 57 | 71 | 116 |
| H, mm | 81 | 96 | 123 | 162 | 199 |
| J, mm | 121 | 147 | 180 | 233 | 315 |
| K, mm | 56 | 69 | 86 | 86 | 86 |
| L, mm | 105 | 110 | 121 | 121 | 121 |
| M, mm | 161 | 179 | 207 | 207 | 207 |
| N, mm | 30 | 30 | 30 | 30 | 30 |
| O, mm | 120 | 120 | 120 | 120 | 120 |
| P, mm | 257 | 273 | 299 | 299 | 299 |

Option:

Shipyard hooks
for capacities
1500 and 3000 kg.

Based on a special
design the shipyard
hooks can be fixed to
avoid slipping
(resp. on steel plates
which were braced
for welding).

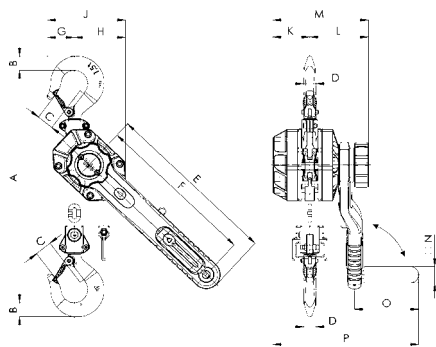

YaleERGO 360®, 750 - 3000 kg, single fall

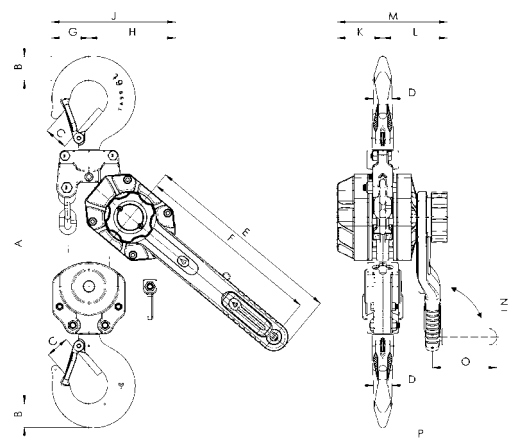

YaleERGO 360®, 6000 kg, double fall

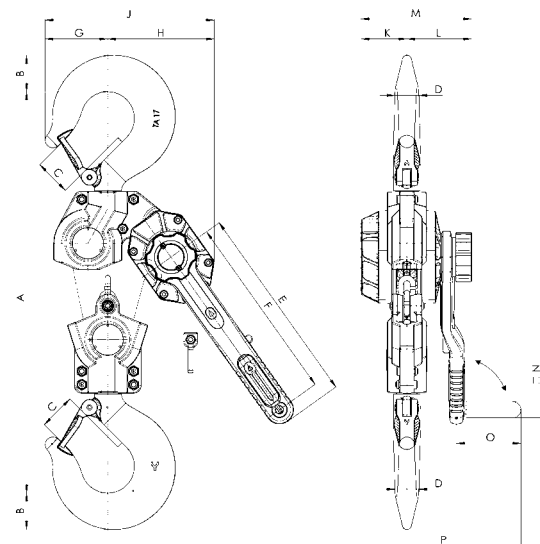
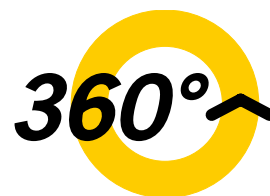

YaleERGO 360®, 9000 kg, three fall

Yale **ERGO 360[®] UT** *Utility!*



Ratchet lever hoist with safety gear

Capacity 1500 - 9000 kg

The Yale **ERGO 360[®] UT** is now also redefining the world of hoists for overhead line construction. The automatically acting safety gear, with a pending patent, once more increases the safety of use.

Here, too, the ergonomic and safety enhancing design of the device and the revolutionary, patented hand lever enable efficient work at any angle, for lifting and pulling applications.

Features

AUTOMATICALLY ACTING SAFETY GEAR

The Yale **ERGO 360[®] UT** has a unique, automatically locking safety device to prevent a sudden drop (patent pending). It guarantees permanent monitoring and is active during operation as well as during inactive moments without the user having to activate it.

In case of emergency, i.e. after failure of the load pressure brake and consequently exceeding the specified speed, the safety gear will automatically activate.

It safely absorbs the load, preventing the creation of larger dynamic forces which could cause further damage.

Due to its design, the device remains in a safe state even in the event of an error (e.g. rusted ratchet pawl, broken springs or other influences such as basic corrosion or dirt).

EXCELLENT CORROSION PROTECTION

A housing optimized for outdoor applications (incl. water drainage holes on all sides) prevents a build up of water and the influence of moisture in extreme conditions (e.g. rain, fluctuations in temperature). External components such as the chain guide and the stripper are zinc plated. Some of the internal moving parts such as the drive pinion, the ratchet pawl, the load chain wheel and the ratchet are MKS coated (Zinc flake coating).

Option

CHAIN STOP & CHAIN CLAW*

Optionally, the devices can be equipped with our proven and tested YKST chain stop or the KKL chain claw.

*The usage is based on each country's specific regulations.

PATENT PENDING
**AUTOMATICALLY ACTING
SAFETY GEAR**
**DESIGNED FOR OPTIMAL
EFFICIENCY & SAFETY**

In accordance with EN 1808 -
Safety requirements for suspended access equipment, 8.9.2

INFO

Extensive corrosion protection measures of the individual components ensure the proper functioning of the safety gear even during long-term use under poor weather conditions.

drain holes on all sides of the housing prevent standing water and moisture

automatically acting safety gear

push button to fully reset the safety gear

Yale **ERGO 360**® UT *Utility!*

direction indicator

patented hand lever

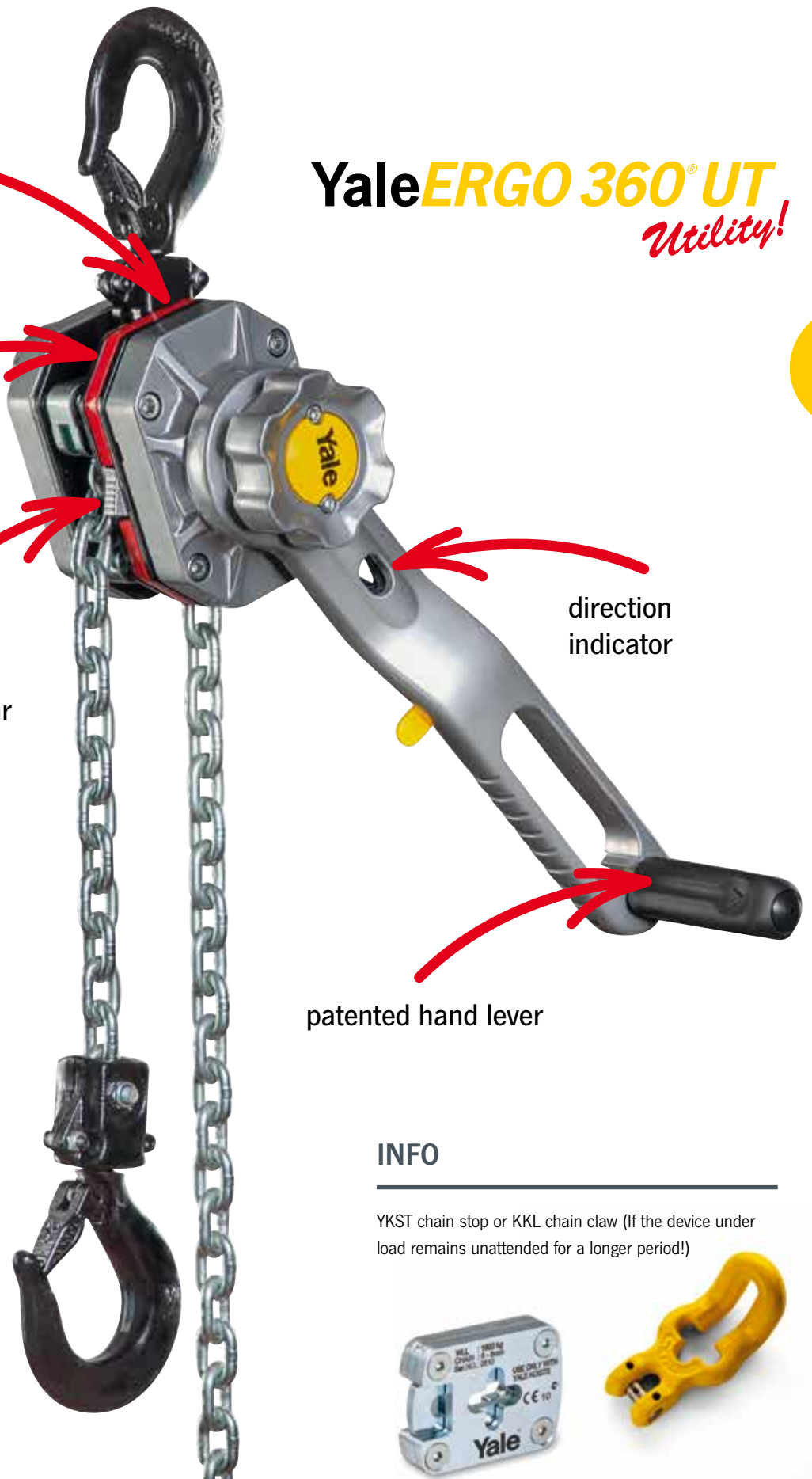

INFO

YKST chain stop or KKL chain claw (If the device under load remains unattended for a longer period!)



STRUCTURE & FUNCTIONALITY OF THE AUTOMATIC SAFETY GEAR

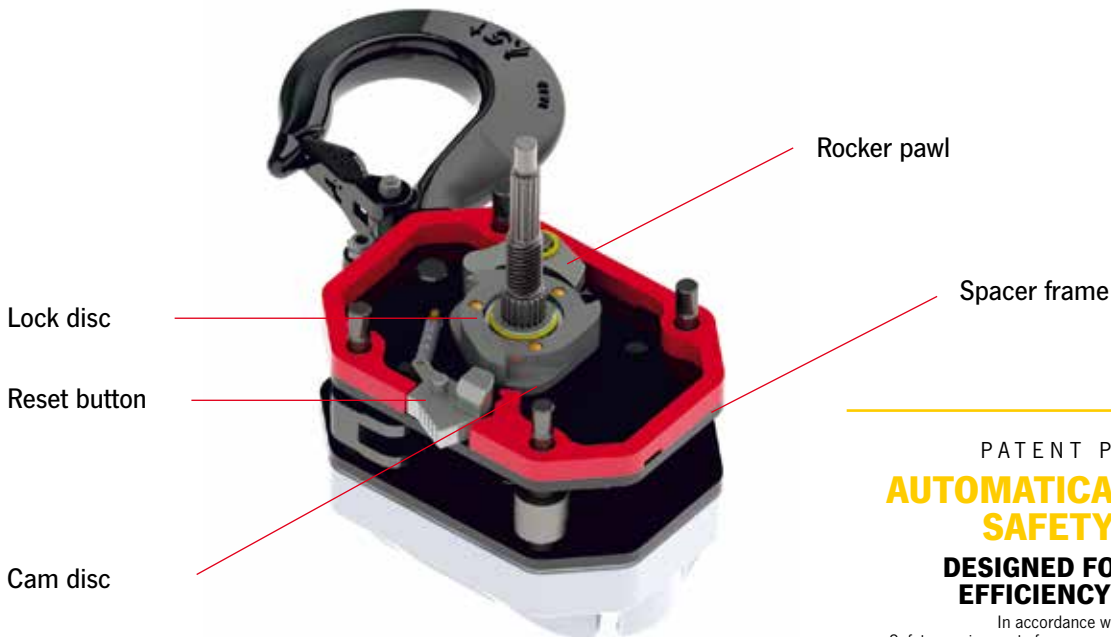

PATENT PENDING
AUTOMATICALLY ACTING SAFETY GEAR
 DESIGNED FOR OPTIMAL EFFICIENCY & SAFETY

In accordance with EN 1808 - Safety requirements for suspended access equipment, 8.9.2

REQUIREMENTS FOR THE REDUNDANT SAFETY GEAR

In accordance with EN 1808 - Safety requirements for suspended access equipment, 8.9.2

- shall automatically engage in the event of overspeed (more than 0.5 m/s)
- the stopping distance must not exceed 500 mm
- shall be capable of being reset
- shall be capable of being tested
- shall permit lifting at any time

INFO

In any cases the load is caught exceeding a speed of 0.5 m/s.

Speeds below 0.5 m/s (corresponds to 2 km/h) are not safety relevant according to EN 1808.

FUNCTION NORMAL OPERATION

Speed < 0.5 m/s

The rocker pawl moves continuously along the contours of the cam disc and lock disc.



FUNCTION ABSORPTION

Speed > 0.5 m/s

As soon as the speed exceeds 0.5 m/s, the rocker pawl engages the lock disc and safely absorbs the load.



Overhead line construction



Aerial construction

Technical data YaleERGO 360® UT

| Model | Art.-No. | Capacity kg | Number of chain falls | Chain dimensions d x p in mm/ design | Lift with one full lever turn mm | Handle pull at WLL daN | Handle pull at WLL with crank daN | Weight at standard lift (1.5 m) kg |
|----------------------|-----------|----------------|--------------------------|---|---|------------------------------|--|---|
| YaleERGO 360 UT 1500 | 192069625 | 1500 | 1 | 7.1 x 21 - T | 21.7 | 31 | 24 | 9.8 |
| YaleERGO 360 UT 3000 | 192069671 | 3000 | 1 | 10 x 28 - V | 20.1 | 43 | 35 | 18.1 |
| YaleERGO 360 UT 6000 | 192071416 | 6000 | 2 | 10 x 28 - V | 10.1 | 46 | 37 | 29.8 |
| YaleERGO 360 UT 9000 | 192083321 | 9000 | 3 | 10 x 28 - V | 6.7 | 50 | 41 | 50.4 |

Dimensions YaleERGO 360® UT

| Model | YaleERGO 360 UT 1500 | YaleERGO 360 UT 3000 | YaleERGO 360 UT 6000 | YaleERGO 360 UT 9000 |
|------------|-------------------------|-------------------------|-------------------------|-------------------------|
| A min., mm | 375 | 445 | 563 | 695 |
| B, mm | 26 | 37 | 45 | 68 |
| C, mm | 31 | 40 | 47 | 68 |
| D, mm | 21 | 28 | 35 | 50 |
| E, mm | 327 | 377 | 377 | 377 |
| F, mm | 300 | 350 | 350 | 350 |
| G, mm | 51 | 57 | 71 | 116 |
| H, mm | 96 | 123 | 162 | 199 |
| J, mm | 147 | 180 | 233 | 315 |
| K, mm | 69 | 86 | 86 | 86 |
| L, mm | 124 | 136 | 136 | 136 |
| M, mm | 193 | 222 | 222 | 222 |
| N mm | 30 | 30 | 30 | 30 |
| O, mm | 120 | 120 | 120 | 120 |
| P, mm | 287 | 314 | 314 | 314 |

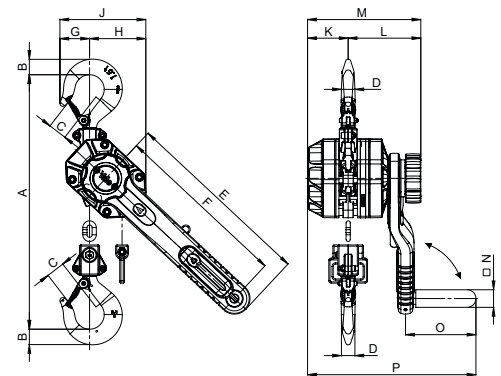

YaleERGO 360® UT, 1500 - 3000 kg, single fall

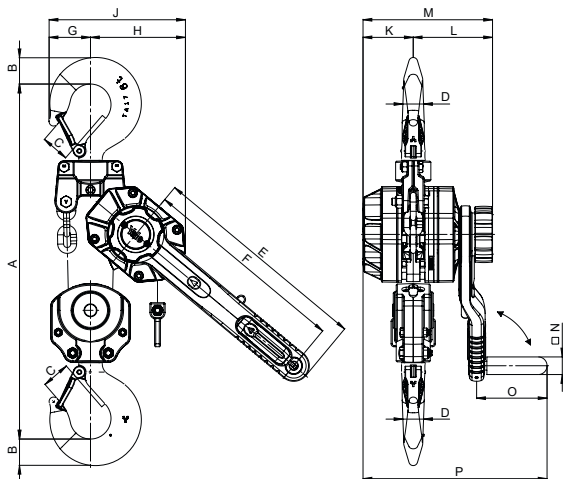

YaleERGO 360® UT, 6000 kg, double fall

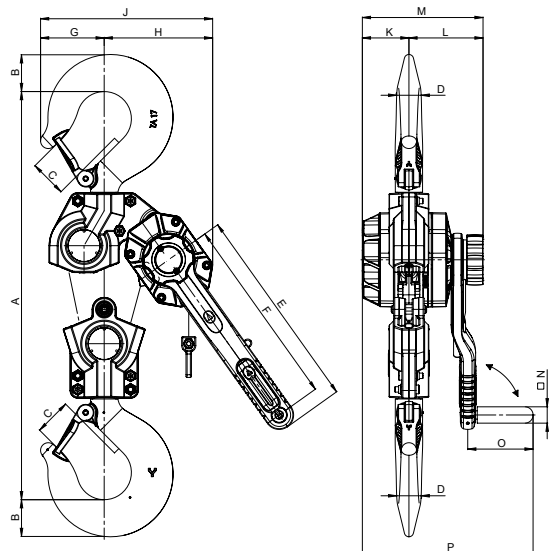

YaleERGO 360® UT, 9000 kg, three fall



Construction of contact lines



Cable car construction



Positioning of loads



INFO

All ratchet lever hoists with a capacity exceeding 750 kg can be used for load attachment according to EN 12195.

Yale hoists and trolleys are not designed for passenger elevation applications and must not be used for this purpose.

AL Ratchet lever hoist

Capacity 750 - 3000 kg

Its low own weight is an advantage. When the hoist has to be frequently carried over longer distances to different assignments. This universal ratchet hoist should not be missing in any service truck.

Features

- The enclosed housing, hand lever and hand wheel are made from high quality aluminium.
- Low effort on hand lever.
- Due to precise needle bearings the hoist can be operated with little effort.
- Standard free chaining device to quickly attach the load or to pull the chain through the hoist in both directions.
- The chain guide is cast into the body to ensure faultless chain movement.
- Alloyed steel link chain with zinc-plated resp. yellow chromated finish, in accordance with national and international standards and regulations.



Technical data AL

| Model | Art.-No. | Capacity kg | Number of chain falls | Chain dimensions d x p in mm/ design | Lift with one full lever turn mm | Handle pull at WLL daN | Weight at standard lift (1.5m) kg |
|---------|-----------|----------------|--------------------------|---|---|------------------------------|--|
| AL 750 | N02041251 | 750 | 1 | 6.3 x 19.1 - T | 30 | 20 | 6.4 |
| AL 1000 | N02041252 | 1000 | 1 | 6.3 x 19.1 - T | 30 | 22 | 6.6 |
| AL 1500 | N02041253 | 1500 | 1 | 7.1 x 21.2 - T | 16 | 21 | 10.0 |
| AL 3000 | N02041254 | 3000 | 1 | 10 x 30.2 - T | 14 | 28 | 18.0 |

Dimensions AL

| Model | AL 750 | AL 1000 | AL 1500 | AL 3000 |
|------------|--------|---------|---------|---------|
| A min., mm | 315 | 325 | 380 | 455 |
| B, mm | 20 | 23 | 27 | 36 |
| C, mm | 22 | 23 | 26 | 33 |
| D, mm | 14 | 16 | 20 | 24 |
| E, mm | 300 | 300 | 300 | 400 |
| F, mm | 106 | 109 | 138 | 168 |
| G, mm | 47 | 47 | 60 | 75 |
| H, mm | 59 | 62 | 78 | 93 |
| J, mm | 154 | 154 | 177 | 212 |
| K, mm | 49 | 49 | 74 | 94 |
| L, mm | 105 | 105 | 103 | 118 |

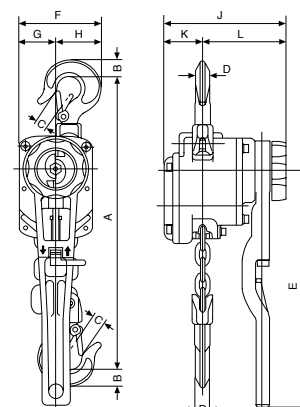

PT Ratchet lever hoist

Capacity 800 - 6300 kg

Ratchet lever hoists PT features improved techniques and ergonomical styling. The advantages of the predecessor range have been maintained and further optimized.

A good, versatile, all round ratchet lever hoist for demanding conditions.

Features

- The proven stamped steel housing provides extremely low weight without limiting the reliability and sturdiness of the unit.
- The short handle lever is fitted with an ergonomic rubber grip.
- Standard free chaining device to quickly attach the load or to pull the chain through the hoist in both directions.
- Alloyed steel link chain with zinc-plated resp. yellow chromated finish, in accordance with national and international standards and regulations.
- Forged suspension and load hooks are made from non-aging, high tensile steel and fitted with robust safety latches.

Option

- All models can be equipped with an overload protection device in the form of a slip clutch which is factory preset to approx. 25% ± 15% overload.



INFO

All ratchet lever hoists with a capacity exceeding 750 kg can be used for load attachment according to EN 12195.

Yale hoists and trolleys are not designed for passenger elevation applications and must not be used for this purpose.



Option:
Overload protection device

Technical data PT

| Model | Art.-No. | Capacity kg | Number of chain falls | Chain dimensions d x p in mm/ design | Lift with one full lever turn mm | Handle pull at WLL daN | Weight at standard lift (1.5 m) kg |
|---------|-----------|----------------|--------------------------|---|---|------------------------------|---|
| PT 800 | N02200005 | 800 | 1 | 5.6 x 17.1 - T | 24 | 26 | 5.5 |
| PT 1600 | N02200006 | 1600 | 1 | 7.1 x 21.2 - T | 23 | 30 | 9.6 |
| PT 3200 | N02200007 | 3200 | 1 | 9 x 27.2 - V | 16 | 38 | 16.0 |
| PT 6300 | N02200008 | 6300 | 2 | 9 x 27.2 - V | 8 | 39 | 31.0 |

Dimensions PT

| Model | PT 800 | PT 1600 | PT 3200 | PT 6300 |
|------------|--------|---------|---------|---------|
| A min., mm | 290 | 330 | 430 | 580 |
| B, mm | 21 | 27 | 36 | 53 |
| C, mm | 24 | 31 | 35 | 46 |
| D, mm | 13 | 20 | 24 | 43 |
| E, mm | 235 | 370 | 370 | 370 |
| F, mm | 120 | 138 | 177 | 259 |
| G, mm | 38 | 41 | 53 | 85 |
| H, mm | 82 | 97 | 124 | 174 |
| J, mm | 142 | 163 | 185 | 185 |
| K, mm | 52 | 65 | 83 | 83 |
| L, mm | 90 | 98 | 102 | 102 |

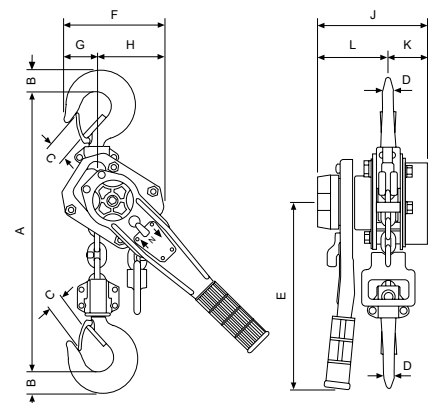



COMPACT & TRANSPORTABLE
**UNIVERSALLY USABLE
& USER FRIENDLY**
LIGHTWEIGHT & CAN BE USED IN
THE SMALLEST AREAS.



Yale **UNOplus** Series A Ratchet lever hoist

Capacity 750 - 6000 kg

The *UNOplus-Series A* ratchet lever hoist is the result of further technical development of the *UNOplus*, which has proven itself over many years.

The versatile tool for lifting, pulling and securing of loads is characterised by its compact design, robust stamped steel construction and the smoothly running free chaining device. The further reduced weight optimizes operation, makes the application even more comfortable and the *UNOplus-Series A* to a convenient, versatile device.

Features

- Due to optimized gearing and improved bearings in the housing cover a minimum effort is required to operate the short hand lever.
- Steel hand wheel as standard.
- Automatic screw-and-disc type load brake with corrosion protected components.
- Standard free chaining device to quickly attach the load or to pull the chain through the hoist in both directions.
- Robust chain guide rollers eliminate fouling and jamming of chain on the load sheave.
- Robust chain end stop.
- Comfortable rubber grip provides for extra protection against slippage.
- Alloyed steel link chain with zinc-plated resp. yellow chromated finish, in accordance with national and international standards and regulations.
- Forged suspension and load hooks are made from non-aging, high tensile steel and fitted with robust safety latches.

INFO

All ratchet lever hoists with a capacity exceeding 750 kg can be used for load attachment according to EN 12195.

Yale hoists and trolleys are not designed for passenger elevation applications and must not be used for this purpose.



We are pleased to send you our new Atex catalogue in PDF format.

Technical data UNOplus-A

| Model | Art.-No. | Capacity kg | Number of chain falls | Chain dimensions d x p in mm/ design | Lift with one full lever turn mm | Handle pull at WLL daN | Weight at standard lift (1.5 m) kg |
|----------------|-----------|----------------|--------------------------|---|---|------------------------------|---|
| UNOplus-A 750 | 192049841 | 750 | 1 | 5.6 x 17.1 - T | 27 | 22 | 6.3 |
| UNOplus-A 1500 | 192049940 | 1500 | 1 | 7.1 x 21 - T | 22 | 35 | 9.2 |
| UNOplus-A 3000 | 192050025 | 3000 | 1 | 10 x 28 - V | 20 | 40 | 16.9 |
| UNOplus-A 6000 | 192050579 | 6000 | 2 | 10 x 28 - V | 10 | 43 | 28.6 |

Dimensions UNOplus-A

| Model | UNOplus-A 750 | UNOplus-A 1500 | UNOplus-A 3000 | UNOplus-A 6000 |
|------------|------------------|-------------------|-------------------|-------------------|
| A min., mm | 312 | 375 | 445 | 563 |
| B, mm | 20 | 26 | 37 | 45 |
| C, mm | 27 | 31 | 40 | 47 |
| D, mm | 18 | 21 | 28 | 35 |
| E, mm | 267 | 267 | 376 | 376 |
| F, mm | 121 | 146 | 180 | 232 |
| G, mm | 40 | 51 | 57 | 71 |
| H, mm | 81 | 95 | 123 | 161 |
| J, mm | 144 | 164 | 193 | 193 |
| K, mm | 53 | 68 | 83 | 83 |
| L, mm | 91 | 96 | 110 | 110 |

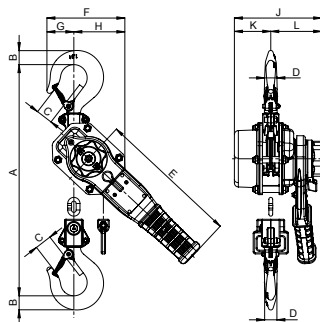

UNOplus-A, 750 - 3000 kg,
single fall

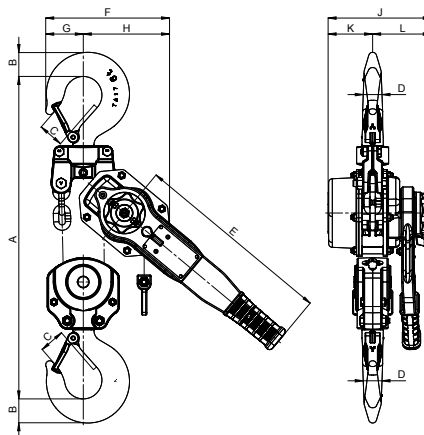

UNOplus-A, 6000 kg,
double fall



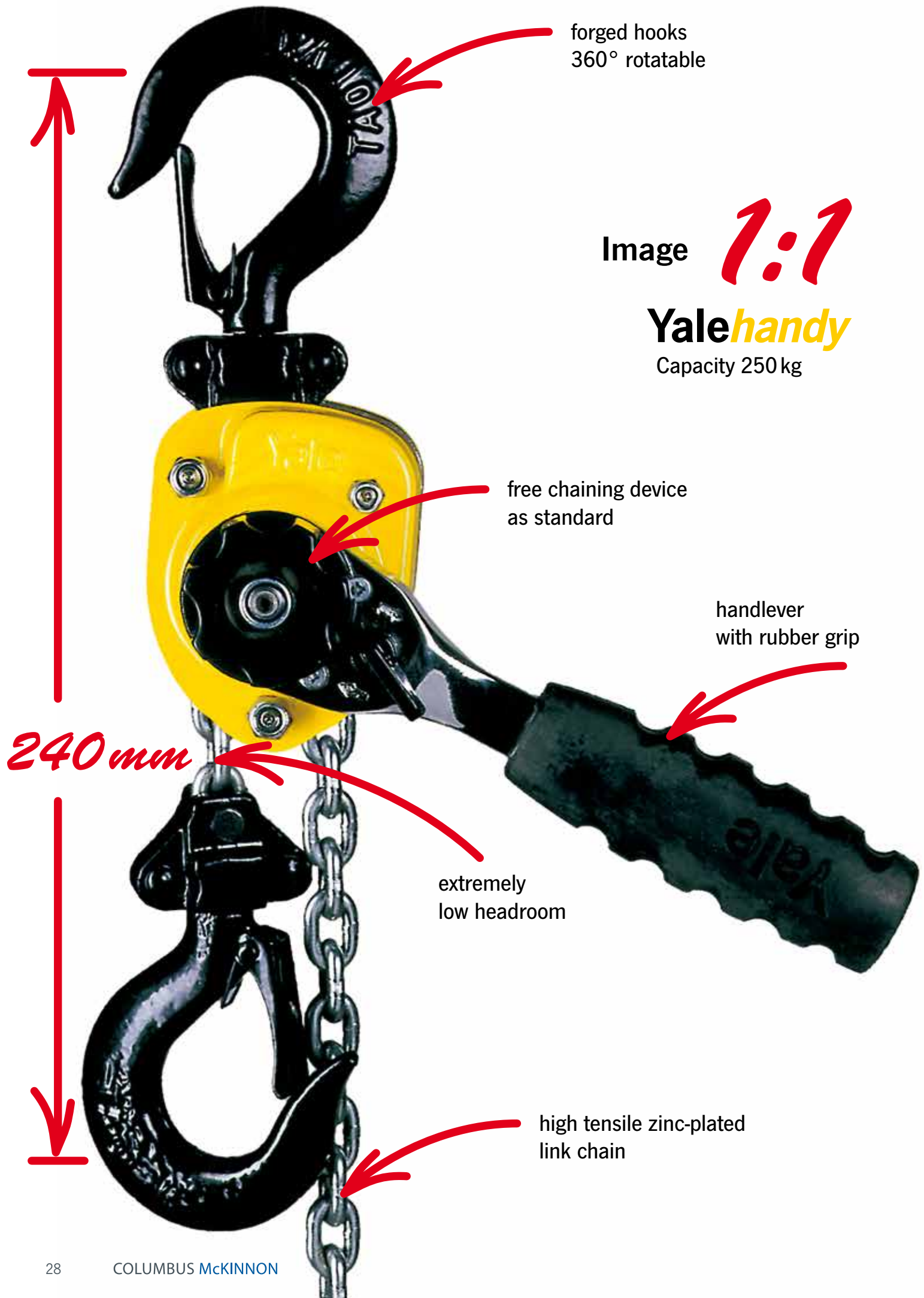

forged hooks
360° rotatable

Image **1:1**

Yalehandy
Capacity 250 kg

free chaining device
as standard

handlever
with rubber grip

240 mm

extremely
low headroom

high tensile zinc-plated
link chain

Yalehandy

Ratchet lever hoist

Capacity 250 - 500 kg

The extreme low own weight and the very compact design make the hoist easy to use even in confined working conditions. Due to the multitude of application possibilities e.g. in industry, trade and service this ratchet lever hoist is indispensable.

Features

- The enclosed design protects the internal parts from contamination.
- The short handle lever is fitted with an ergonomic rubber grip.
- All parts of the disc type load brake are manufactured from high quality materials and are corrosion protected.
- Standard free chaining device to quickly attach the load or to pull the chain through the hoist in both directions.
- Alloyed steel link chain with zinc-plated resp. yellow chromated finish, in accordance with national and international standards and regulations.
- Forged suspension and load hooks are made from non-aging, high tensile steel and fitted with robust safety latches.



INFO

Yale hoists and trolleys are not designed for passenger elevation applications and must not be used for this purpose.

Technical data Yalehandy

| Model | Art.-No. | Capacity kg | Number of chain falls | Chain dimensions d x p in mm/ design | Lift with one full lever turn mm | Handle pull at WLL daN | Weight at standard lift (1.5 m) kg |
|---------------|-----------|----------------|-----------------------|--|-------------------------------------|---------------------------|---------------------------------------|
| Yalehandy 250 | N02300018 | 250 | 1 | 4 x 12 - T | 80 | 25 | 2.2 |
| Yalehandy 500 | N02300070 | 500 | 1 | 4 x 12 - V | 40 | 25 | 2.8 |

Dimensions Yalehandy

| Model | Yalehandy 250 | Yalehandy 500 |
|------------|---------------|---------------|
| A min., mm | 240 | 282 |
| B, mm | 20 | 17 |
| C, mm | 21 | 24 |
| D, mm | 14 | 12 |
| E, mm | 160 | 160 |
| F, mm | 72 | 104 |
| G, mm | 33 | 38 |
| H, mm | 39 | 66 |
| J, mm | 98 | 116 |
| K, mm | 21 | 36 |
| L, mm | 77 | 80 |

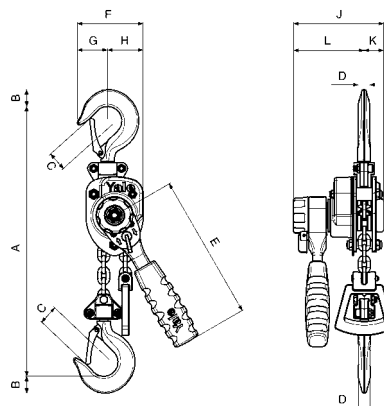

INFO

All ratchet lever hoists with a capacity exceeding 750 kg can be used for load attachment according to EN 12195.

Yale hoists and trolleys are not designed for passenger elevation applications and must not be used for this purpose.



Silverline HZS Ratchet lever hoists

Capacity 750 - 6000 kg

The Silverline HZS is designed and built for safe and efficient operation.

A hoist with low maintenance - at an economical price.

Features

- Strong bolts between side plates and housing cover ensure increased stability.
- Chain guide rollers eliminate fouling and jamming of chain.
- Bearings for side plates permit a long service life.
- Zinc-plated load chain as standard.
- Forged suspension and load hooks are made from high tensile steel and fitted with safety latches.

Technical data Silverline HZS

| Model | Art.-No. | Capacity kg | Number of chain falls | Chain dimensions d x p in mm/ design | Lift with one full lever turn mm | Handle pull at WLL daN | Weight at standard lift (1.5 m) kg |
|----------|-----------|----------------|--------------------------|---|---|------------------------------|---|
| HZS 750 | N02300113 | 750 | 1 | 6 x 18 - T | 20 | 20 | 7.0 |
| HZS 1500 | N02300114 | 1500 | 1 | 8 x 24 - T | 10 | 36 | 10.0 |
| HZS 3000 | N02300115 | 3000 | 1 | 10 x 30 - T | 17 | 38 | 18.0 |
| HZS 6000 | N02300116 | 6000 | 2 | 10 x 30 - T | 9 | 39 | 27.0 |

Dimensions Silverline HZS

| Model | HZS 750 | HZS 1500 | HZS 3000 | HZS 6000 |
|------------|---------|----------|----------|----------|
| A min., mm | 330 | 410 | 490 | 640 |
| B, mm | 24 | 30 | 45 | 55 |
| C, mm | 26 | 31 | 34 | 46 |
| D, mm | 14 | 18 | 26 | 37 |
| E, mm | 280 | 410 | 410 | 410 |
| F, mm | 111 | 175 | 190 | 240 |
| G, mm | 33 | 50 | 60 | 80 |
| H, mm | 78 | 125 | 130 | 160 |
| J, mm | 142 | 180 | 195 | 200 |
| K, mm | 55 | 75 | 85 | 90 |
| L, mm | 87 | 105 | 110 | 110 |

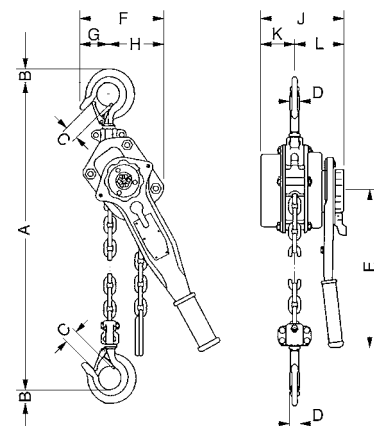

Silverline Stira S Hand chain hoist

Capacity 500 - 5000 kg

The hand chain run is just as smooth as on the models Yalelift 360 and VSIII, but the Silverline Stira S series is a low-priced alternative to the high-quality units.

Features

- Strong bolts between side plates and housing cover ensure increased stability.
- Chain guide rollers eliminate fouling and jamming of chain.
- The design prevents the hand chain from jamming and jumping off.
- Bearings for side plates permit a long service life.
- Zinc-plated load chain as standard.
- Forged suspension and load hooks are made from high tensile steel and fitted with safety latches.



INFO

Yale hoists and trolleys are not designed for passenger elevation applications and must not be used for this purpose.

Technical data Silverline Stira S

| Model | Art.-No. | Capacity kg | Number of chain falls | Chain dimensions d x p in mm/ design | Lift per 1 m hand chain overhaul mm | Handle pull at WLL daN | Weight at standard lift (3 m) kg |
|--------------|-----------|----------------|--------------------------|---|--|------------------------------|---|
| Stira S 500 | N04500041 | 500 | 1 | 6 x 18 - T | 29 | 23 | 12.0 |
| Stira S 1000 | N04500042 | 1000 | 1 | 6 x 18 - T | 27 | 31 | 14.0 |
| Stira S 1500 | N04500043 | 1500 | 1 | 8 x 24 - T | 20 | 32 | 19.0 |
| Stira S 2000 | N04500044 | 2000 | 1 | 8 x 24 - T | 15 | 36 | 21.0 |
| Stira S 3000 | N04500045 | 3000 | 2 | 8 x 24 - T | 5 | 34 | 27.0 |
| Stira S 5000 | N04500046 | 5000 | 2 | 10 x 30 - T | 3 | 41 | 43.0 |

Dimensions Silverline Stira S

| Model | Stira S 500 | Stira S 1000 | Stira S 1500 | Stira S 2000 | Stira S 3000 | Stira S 5000 |
|--------|----------------|-----------------|-----------------|-----------------|-----------------|-----------------|
| A min. | 270 | 317 | 399 | 414 | 465 | 636 |
| B | 18 | 23 | 28 | 28 | 35 | 46 |
| C | 30 | 34 | 38 | 41 | 48 | 52 |
| D | 13 | 16 | 20 | 23 | 27 | 35 |
| E | 127 | 158 | 174 | 187 | 199 | 253 |
| F | 131 | 140 | 161 | 161 | 161 | 186 |
| G | 74 | 77 | 82 | 84 | 82 | 93 |
| H | 57 | 63 | 79 | 77 | 79 | 91 |
| K | 220 | 250 | 280 | 300 | 310 | 400 |

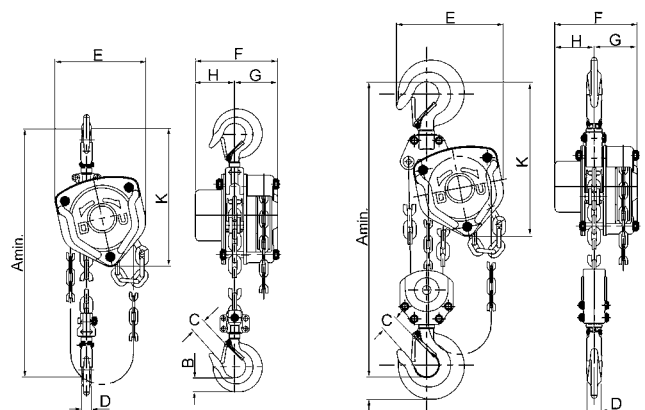

Silverline Stira S
500 - 2000 kg, single fall

Silverline Stira S
3000 - 5000 kg, double fall



Yale VS III

Hand chain hoist

Capacity 250 - 5000 kg

Extremely low overall height allows optimal use of available headroom. Fully enclosed stamped steel housing allows also outdoor use. The improved hand chain guide prevents canting or jamming of the hand chain, leading to a smooth running of the chain. High quality bearings on side plates, gearbox and load chain sheave ensure smooth operation of load chain and drive pinion. Optimized hand forces set standards for easy operation. The hooks are equipped with robust safety latches and can rotate 360°.

Features

- Strong bolts between side plates and housing cover and the reinforced hand wheel cover ensure increased stability.
- Precision machined guide rollers ensure smooth running of the load chain.
- High quality bearings for gearbox, side plates and load chain sheave permit a long service life.
- Zinc-plated and yellow-chromated brake parts and guide rollers ensure increased corrosion protection.
- Zinc-plated load chain as standard for added corrosion protection.

Options

- Overload protection device (from 500 kg available)
- Chain container



Load chain sheave with needle bearing



Side plate with ball bearing



Housing cover with ball bearing

Yale VS III

Hand chain hoist

Capacity 10000 - 50000 kg

Having long years of experience with this solid product, we decided to extend the VS III series by the load capacities 10t, 20t, 30t and 50t.

In order to serve all industries (even the paper- or the ship industry), the VS III lifts the loads very sensitively, as the components and construction parts have been positioned very precisely.

Features

- Strong bolts between side plates and housing cover and the reinforced hand wheel cover ensure increased stability.
- Precision machined guide rollers ensure smooth running of the load chain.
- High quality bearings for gearbox, side plates and load chain sheave permit a long service life.
- Zinc-plated and yellow-chromated brake parts and guide rollers ensure increased corrosion protection.
- Zinc-plated load chain as standard for added corrosion protection.

Options

- Overload protection device (from 500 kg available)
- Chain container



SERIES EXTENSION
NOW WITH HIGH SWL!
 10000 - 50000 kg

INFO

To avoid bruising or injuries, the chain inlet as well as the top hook connection is covered in protective material.

Technical data VSIII

| Model | Art.-No. | Capacity in kg/ Number of chain falls | Chain dimensions d x p in mm/ design | Lift per 1 m hand chain overhaul mm | Handle pull at WLL daN | Weight at standard lift (3 m) kg |
|--------------|-----------|--|---|---|---------------------------|-------------------------------------|
| VSIII 0,25/1 | N04200123 | 250/1 | 4 x 12 - T | 50 | 20 | 4.9 |
| VSIII 0,5/1 | N04200124 | 500/1 | 5 x 15 - T | 26 | 21 | 9.0 |
| VSIII 1,0/1 | N04200125 | 1000/1 | 6 x 18 - T | 24 | 24 | 11.5 |
| VSIII 1,5/1 | N04200134 | 1500/1 | 8 x 24 - T | 17 | 30 | 17.5 |
| VSIII 2,0/1 | N04200126 | 2000/1 | 8 x 24 - T | 19 | 32 | 19.0 |
| VSIII 2,0/2 | N04200127 | 2000/2 | 6 x 18 - T | 15 | 29 | 17.3 |
| VSIII 3,0/1 | N04200128 | 3000/1 | 10 x 30 - T | 12 | 40 | 31.0 |
| VSIII 3,0/2 | N04200129 | 3000/2 | 8 x 24 - T | 10 | 37 | 27.0 |
| VSIII 5,0/2 | N04200130 | 5000/2 | 10 x 30 - T | 8 | 41 | 4.0 |
| VSIII 10/4 | 192039383 | 10000/4 | 10 x 30 - T | 2.84 | 37 | 78.5 |
| VSIII 20/8 | 192039384 | 20000/8 | 10 x 30 - T | 1.42 | 44.5 | 197 |
| VSIII 30/12 | 192039385 | 30000/12 | 10 x 30 - T | 0.83 | 46.3 | 268 |
| VSIII 50/18 | 192039386 | 50000/18 | 10 x 30 - T | 0.56 | 53.6 | 540 |

Dimensions VSIII

| Model | VSIII 0,25/1 | VSIII 0,5/1 | VSIII 1,0/1 | VSIII 1,5/1 | VSIII 2,0/1 | VSIII 2,0/2 | VSIII 3,0/1 | VSIII 3,0/2 | VSIII 5,0/2 | VSIII 10/4 | VSIII 20/8 | VSIII 30/12 | VSIII 50/18 |
|------------|--------------|-------------|-------------|-------------|-------------|-------------|-------------|-------------|-------------|------------|------------|-------------|-------------|
| A min., mm | 290 | 350 | 380 | 450 | 460 | 490 | 570 | 580 | 700 | 860 | 950 | 1112 | 1700 |
| B, mm | 12 | 21 | 27 | 33 | 37 | 37 | 46 | 46 | 56 | 63 | 90 | 90 | 165 |
| C, mm | 26 | 28 | 32 | 37 | 41 | 41 | 44 | 44 | 50 | 65 | 86 | 85 | 135 |
| D, mm | 11 | 16 | 19 | 22 | 27 | 27 | 31 | 31 | 37 | 47 | 69 | 67 | 108 |
| E, mm | 118 | 145 | 158 | 180 | 205 | 170 | 240 | 220 | 250 | 463 | 860 | 704 | 776 |
| F, mm | 113 | 140 | 155 | 175 | 180 | 155 | 210 | 175 | 190 | 104 | 200 | 410 | 627 |
| G, mm | 65 | 80 | 87 | 85 | 94 | 87 | 110 | 94 | 95 | 55 | 100 | 225 | 314 |
| H, mm | 48 | 60 | 68 | 90 | 86 | 68 | 100 | 81 | 95 | 50 | 100 | 186 | 314 |
| K, mm | 190 | 240 | 270 | 300 | 320 | 285 | 370 | 340 | 410 | 448 | 508 | 528 | 656 |

INFO

Yale hoists and trolleys are not designed for passenger elevation applications and must not be used for this purpose.



Option: Chain container

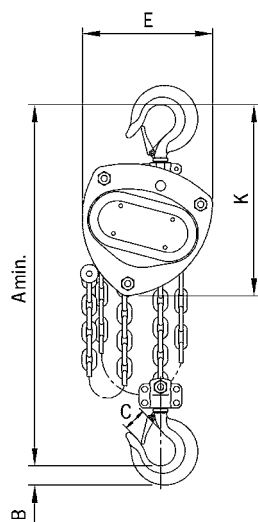

VSIII, 250 - 3000 kg, single fall

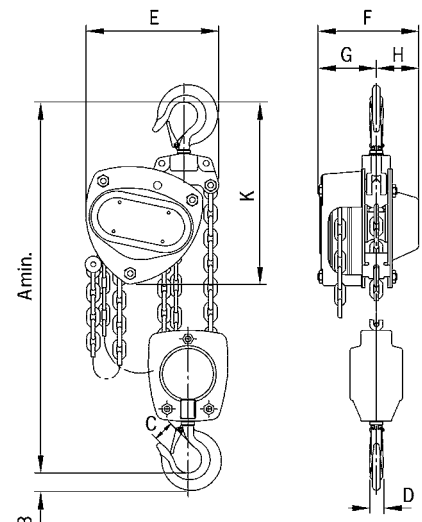

VSIII, 2000 - 5000 kg, double fall

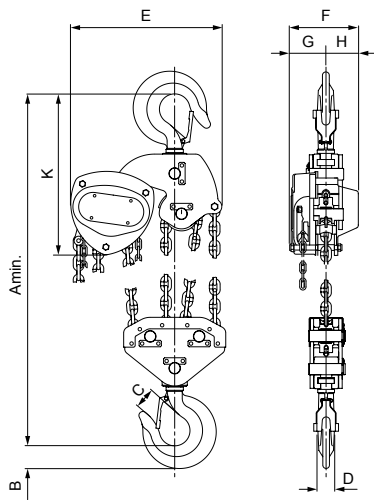

VSIII, 10000 kg, four chain falls

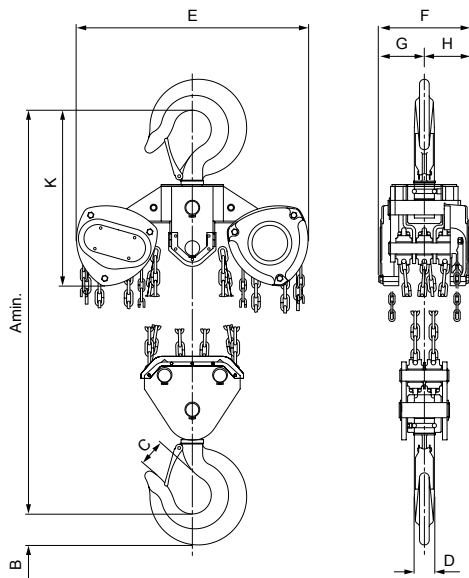

VSIII, 20000 kg, eight chain falls

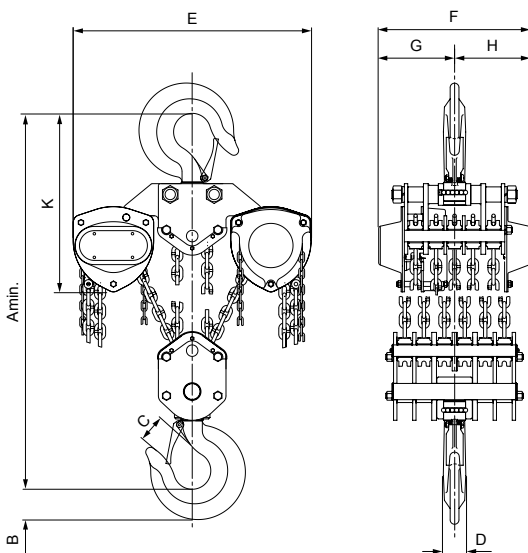

VSIII, 30000 kg, twelve chain falls

INFO

HTG trolleys for hand chain hoists upwards 10000 kg please see pages 54-57.

SERIES EXTENSION
NOW WITH HIGH SWL!
10000 - 50000 kg

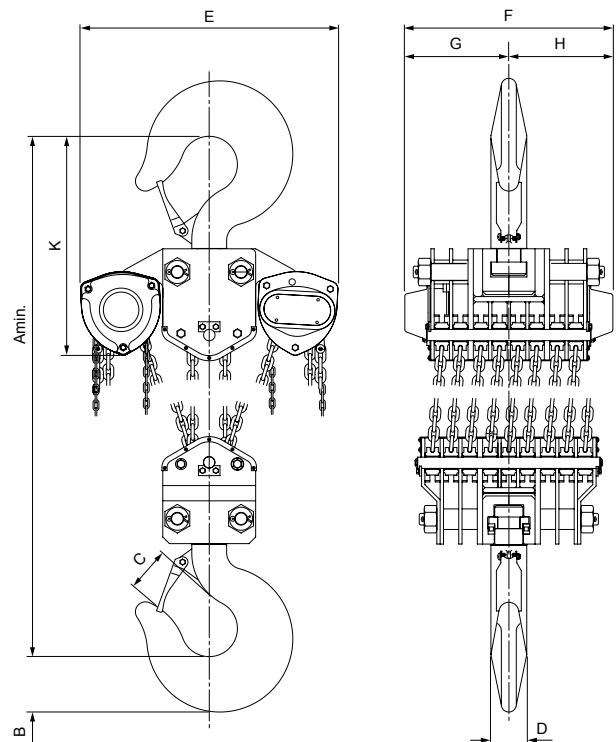
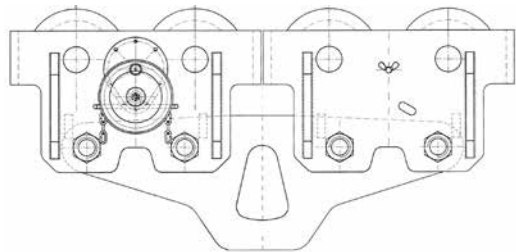

VSIII, 50000 kg, eighteen chain falls



EXPERIENCE THE ADVANTAGE OF 360°



We are pleased to send you our new ATEX catalogue in PDF format.

INFO

Easy modification from Yalelift 360 to Yalelift IT is possible.

Yalelift 360

Hand chain hoist

Capacity 500 - 10000 kg

Areas of operation as well as operator conditions have been improved far beyond those of a classical hand chain hoist.

Features

- The enclosed robust stamped steel housing protects all internal components even in the toughest conditions.
- The extremely low headroom allows maximum use of the lifting height.
- The revolutionary 360° rotating hand chain guide allows the operator to work from virtually any position, in confined spaces or above the load. The Yalelift can even be operated from the side of the load which also makes it possible to use the hoist for horizontal pulling or tensioning. Due to the additional flexibility, the operator is no longer forced to work in the danger zone near the load.
- The brake system is extremely quiet and guarantees operational safety and improved serviceability due to omission of the vulnerable ratchet pawls. All parts are made of high quality materials, additionally zinc-plated or yellow-chromated to increase corrosion prevention.
- Chain guide and gearbox are almost totally enclosed. Even under the toughest conditions the internal gearbox remains protected.
- The hardened load sheave with four precision machined pockets ensures accurate movement of the load chain.
- The surface protected zinc-plated alloy steel load chains fulfil all requirements of current national and international standards and regulations. They are optimally matched to the load sprocket and ensure safe and long-lasting operation of the unit.
- Forged load and suspension hooks that yield under overload instead of breaking, are made of high tensile steel. The hooks are fitted with robust safety latches and rotate 360°.

Options

- Adjustable overload protection device.
- Chain container
- Corrosion resistant version

Yalelift 360

Hand chain hoist, 20t

Capacity 20000 kg

In spite of its high capacity, the Yalelift 360 20t features a compact design.

Features

- All components are made of high quality materials, some components are zinc-plated or yellow-chromated for added corrosion protection. This ensures that also heaviest loads are held reliably.
- The enclosed robust stamped steel body resists in the toughest conditions and allows outside operation.
- The hardened load sheave with five precision machined pockets ensures accurate movement of the load chain.
- The low headroom (hook-to-hook dimension 1065 mm) allows maximum use of the lifting height.
- The Yalelift 360 20t is equipped with six chain falls which results in higher speed and lower weight.

Options

- Adjustable overload protection device.
- Chain container
- Corrosion resistant version

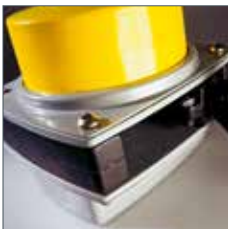

The robust stamped steel housing with four stay bolts is resistant to the toughest working conditions.



Chain guide

UPGRADE
SIMPLE & FLEXIBLE
 FROM Yalelift 360 TO Yalelift IT

Technical data Yalelift

| Model | Art.-No. | Capacity kg | Number of chain falls | Chain dimensions d x p in mm/ design | Lift per 1 m hand chain overhaul mm | Handle pull at WLL daN | Weight at standard lift (3 m) kg |
|----------|-----------|----------------|--------------------------|---|--|------------------------------|---|
| YL 500 | N04700109 | 500 | 1 | 5 x 15 - T | 33 | 21 | 9 |
| YL 1000 | N04700110 | 1000 | 1 | 6 x 18 - T | 20 | 30 | 13 |
| YL 2000 | N04700111 | 2000 | 1 | 8 x 24 - T | 14 | 32 | 21 |
| YL 3000 | N04700112 | 3000 | 1 | 10 x 30 - V | 12 | 38 | 34 |
| YL 5000 | N04700113 | 5000 | 2 | 10 x 30 - T | 6 | 34 | 48 |
| YL 10000 | N04700075 | 10000 | 3 | 10 x 30 - V | 4 | 44 | 71 |
| YL 20000 | N04700077 | 20000 | 6 | 10 x 30 - V | 2 | 2 x 44 | 196 |

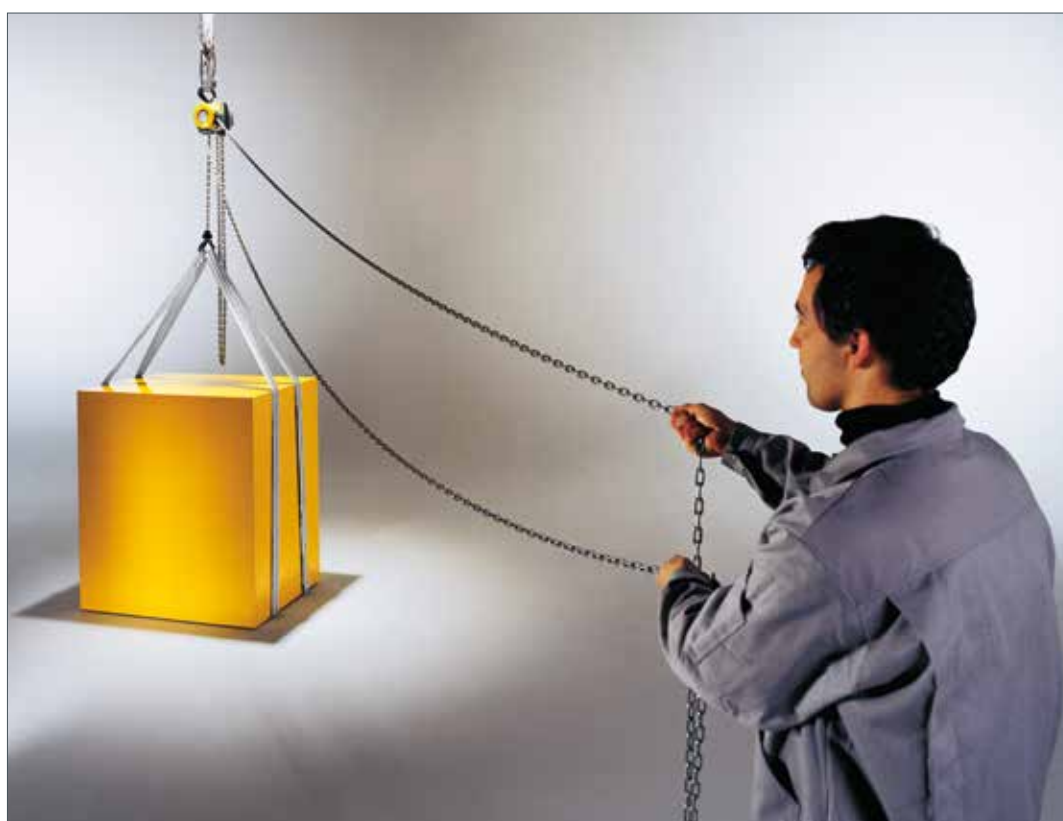
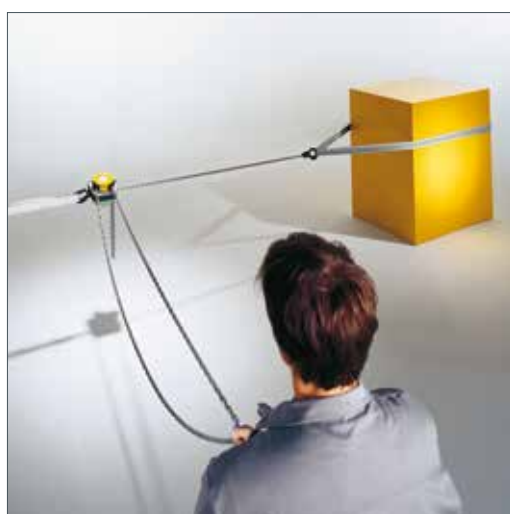

Dimensions Yalelift

| Model | YL 500 | YL 1000 | YL 2000 | YL 3000 | YL 5000 | YL 10000 | YL 20000 |
|------------|--------|---------|---------|---------|---------|----------|----------|
| A min., mm | 300 | 335 | 395 | 520 | 654 | 825 | 1065 |
| B, mm | 17 | 22 | 30 | 38 | 45 | 68 | 85 |
| C, mm | 24 | 29 | 35 | 40 | 47 | 68 | 64 |
| D, mm | 133 | 156 | 182 | 220 | 220 | 220 | 303 |
| E, mm | 148 | 175 | 203 | 250 | 250 | 383 | 555 |
| F, mm | 148 | 167 | 194 | 219 | 219 | 219 | 250 |
| G, mm | 139 | 164 | 192 | 225 | 242 | 326 | 391 |
| H, mm | 206 | 242 | 283 | 335 | 352 | 436 | 501 |
| I, mm | 24 | 24 | 31 | 34 | 21 | 136 | - |
| K, mm | 61 | 70 | 83 | 95 | 95 | 95 | 396 |
| L, mm | 87 | 97 | 111 | 124 | 124 | 124 | 125 |
| M, mm | 110 | 125 | 156 | 178 | 285 | 401 | 471 |
| N, mm | 14 | 19 | 22 | 30 | 37 | 50 | 56 |

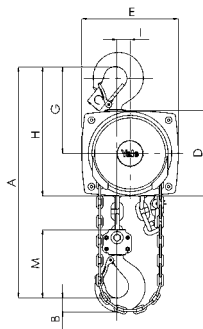

Yalelift 360, 500 - 3000 kg, single fall

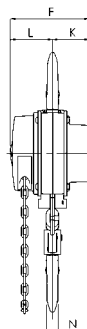

Yalelift 360, 5000 kg, double fall

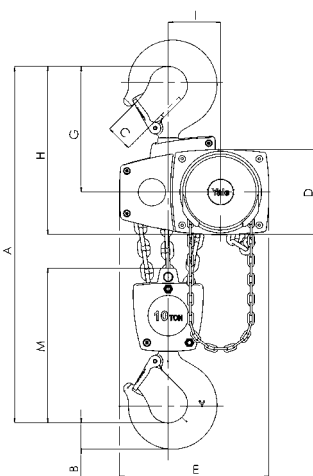
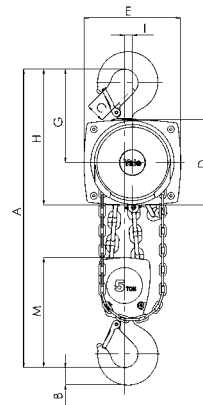

Yalelift 360, 10000 kg, three falls

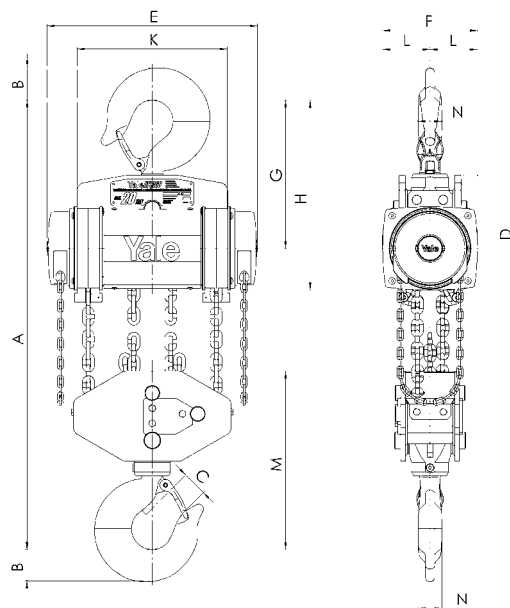

Yalelift 360, 20000 kg, six falls



Depicted rubber buffers are optionally available!

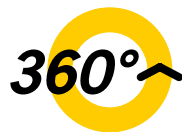

**EXPERIENCE THE
ADVANTAGE OF 360°**

Yalelift 360

YL IT – Hand chain hoist
with integrated push or with
integrated geared trolley

Capacity 500 - 20000 kg

The combination of the Yalelift 360 with a low headroom manual trolley provides even more flexibility in the application.

Features

- All units of this series up to a capacity of 3000 kg are built with a single chain fall, the min. headroom (Dim. A) has been further reduced. Ideal for applications with low ceilings and limited headroom.
- The approved and almost stepless adjustment system of the trolley enables the simple and quick assembly due to adjusting nuts.
- Trolleys up to 5t capacity are offered for two beam ranges; range A for a flange width of up to 180 mm is standard and covers approx. 80% of all applications. Conversion to range B for beam width up to 300 mm can be easily accomplished.
- The trolley wheels are designed for a max. beam profile incline of 14% (DIN 1025-part 1), excellent rolling features are guaranteed by pre-lubricated, encapsulated ball bearings.
- Anti-drop and anti-tilt devices as standard.

Options

- Adjustable overload protection device.
- Chain container
- Rubber buffers
- Corrosion resistant version
- Beam locking device to secure the unloaded hoist with integrated trolley in a fixed position on the beam (park position e.g. on ships).

UPGRADE

**SIMPLE & FLEXIBLE
FROM Yalelift 360 TO Yalelift IT**

Technical data Yalelift ITP - with integrated push trolley

| Model | Art.-No. | Capacity in kg/ Number of chain falls | Size | Beam flange width b mm | Beam flange thickness t max. mm | Curve radius min. m | Weight at standard lift (3 m) kg |
|------------|-----------|--|------|------------------------------|---------------------------------------|---------------------------|--|
| YLITP 500 | N04900044 | 500/1 | A | 50 - 180 | 19 | 0.9 | 20 |
| YLITP 1000 | N04900045 | 1000/1 | A | 50 - 180 | 19 | 0.9 | 27 |
| YLITP 2000 | N04900046 | 2000/1 | A | 58 - 180 | 19 | 1.15 | 44 |
| YLITP 3000 | N04900047 | 3000/1 | A | 74 - 180 | 27 | 1.5 | 77 |
| YLITP 5000 | N04900020 | 5000/2 | A | 98 - 180 | 27 | 2.0 | 125 |
| YLITP 500 | - | 500/1 | B | 180 - 300 | 19 | 0.9 | 21 |
| YLITP 1000 | - | 1000/1 | B | 180 - 300 | 19 | 0.9 | 29 |
| YLITP 2000 | - | 2000/1 | B | 180 - 300 | 19 | 1.15 | 46 |
| YLITP 3000 | - | 3000/1 | B | 180 - 300 | 27 | 1.4 | 79 |
| YLITP 5000 | - | 5000/2 | B | 180 - 300 | 27 | 1.8 | 129 |

Technical data Yalelift ITG - with integrated geared trolley

| Model | Art.-No. | Capacity in kg/ Number of chain falls | Size | Beam flange width b mm | Beam flange thickness t max. mm | Curve radius min. m | Weight at standard lift (3 m) kg |
|--------------------------|-----------|--|------|------------------------------|---------------------------------------|---------------------------|--|
| YLITG 500 | N04900056 | 500/1 | A | 50 - 180 | 19 | 0.9 | 24 |
| YLITG 1000 | N04900057 | 1000/1 | A | 50 - 180 | 19 | 0.9 | 32 |
| YLITG 2000 | N04900058 | 2000/1 | A | 58 - 180 | 19 | 1.15 | 49 |
| YLITG 3000 | N04900059 | 3000/1 | A | 74 - 180 | 27 | 1.5 | 82 |
| YLITG 5000 | N04900060 | 5000/2 | A | 98 - 180 | 27 | 2.0 | 130 |
| YLITG 500 | - | 500/1 | B | 180 - 300 | 19 | 0.9 | 25 |
| YLITG 1000 | - | 1000/1 | B | 180 - 300 | 19 | 0.9 | 33 |
| YLITG 2000 | - | 2000/1 | B | 180 - 300 | 19 | 1.15 | 50 |
| YLITG 3000 | - | 3000/1 | B | 180 - 300 | 27 | 1.4 | 84 |
| YLITG 5000 | - | 5000/2 | B | 180 - 300 | 27 | 1.8 | 134 |
| YLITG 10000 | N04900061 | 10000/3 | B | 125 - 310 | 40 | 1.8 | 202 |
| YLITG 20000 ¹ | N04900055 | 20000/6 | B | 180 - 310 | 40 | 9.5 | on request |

¹Dimensions on request



COMPLETE SERIES YALELIFT
**CAPACITIES FROM
 500-20000 KG**
 WITH
**INTEGRATED
 PUSH OR GEARED TROLLEY**



We are pleased to send you our new
 ATEX catalogue in PDF format.

Dimensions Yalelift ITP/ITG

| Model | YLIT 500 | YLIT 1000 | YLIT 2000 | YLIT 3000 | YLIT 5000 | YLIT 10000 |
|------------------------|----------|-----------|-----------|-----------|-----------|------------|
| A min., mm | 245 | 272 | 323 | 382 | 550 | 784 |
| A1, mm | 158 | 178 | 205.5 | 252 | 260.5 | 380 |
| A2, mm | - | - | - | - | - | - |
| B, mm | 17 | 22 | 30 | 38 | 45 | 68 |
| C, mm | 24 | 29 | 35 | 40 | 47 | 68 |
| D, mm | 14 | 19 | 22 | 30 | 37 | 50 |
| F (Geared trolley), mm | 92 | 92 | 91 | 107 | 149.5 | 113 |
| H1, mm | 24.5 | 24 | 23.5 | 32 | 30.5 | 55 |
| I (Push trolley), mm | 71.5 | 71.5 | 95.5 | 131 | 142.5 | 169 |
| I (Geared trolley), mm | 76.5 | 76.5 | 98 | 132.5 | 148.5 | 169 |
| L, mm | 270 | 310 | 360 | 445 | 525 | 430 |
| L1, mm | 130 | 130 | 150 | 180 | 209 | 200 |
| L2, mm | 159 | 175 | 207 | 256 | 283 | 261 |
| M, mm | M 18 | M 22 | M 27 | M 30 | M 42 | M 48 |
| O, mm | 60 | 60 | 80 | 112 | 125 | 150 |
| P (Geared trolley), mm | 108 | 110 | 112 | 112 | 117 | 158 |
| T (Area A), mm | 280 | 290 | 305 | 320 | 364 | - |
| T (Area B), mm | 400 | 410 | 425 | 440 | 484 | 540 |

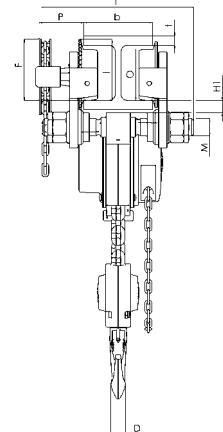
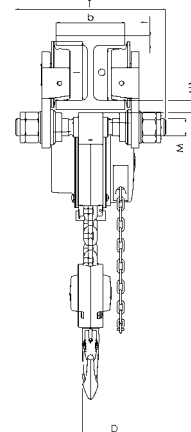
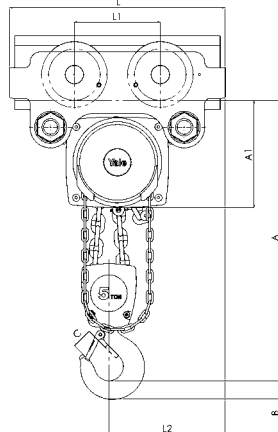
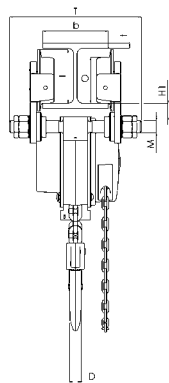
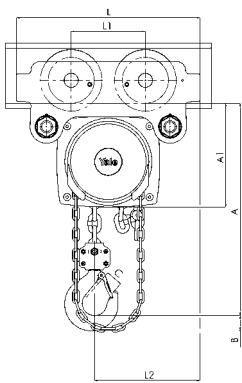

Yalelift ITP, 500 - 3000 kg, single fall

Yalelift ITP/ITG, 5000 kg, double fall

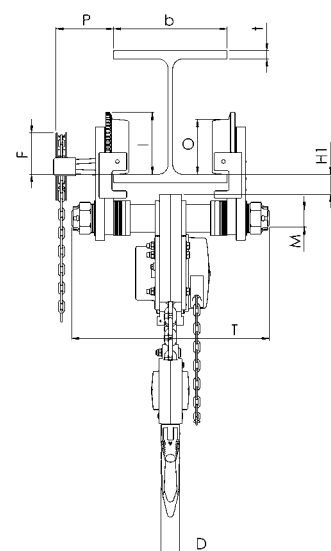
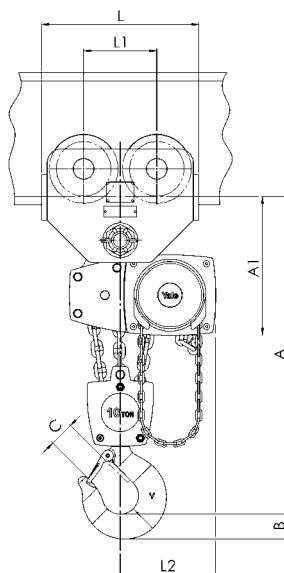
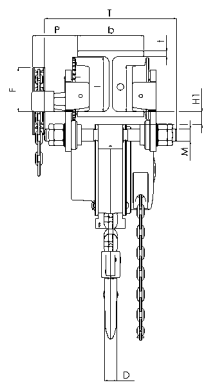
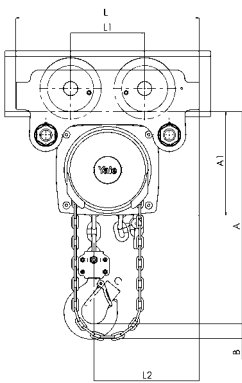

Yalelift ITG, 500 - 3000 kg, single fall

Yalelift ITG, 10000 kg, three falls

Yalelift 360

YL LH – Hand chain hoist with integrated push or with integrated geared trolley (low headroom)

Capacity 500 - 10000 kg

The hand chain hoist model Yalelift LH with integrated low headroom manual trolley is the consequent further development of the Yalelift IT. Wherever an even smaller headroom is essential, the Yalelift LH is the ideal choice.

Features

- The specially developed chain reeving system and chain guide allow the bottom block to be pulled laterally to the hoist even further up and almost against the beam flange.
- The integrated design of the innovative Yalelift LH uses the same manual trolleys as incorporated in the Yalelift IT series.
- All units of this series up to a capacity of 3000 kg are built with a single chain fall.
- The approved and almost stepless adjustment system of the trolley enables the simple and quick assembly due to adjusting nuts.
- Trolleys up to 5t capacity are offered for two beam ranges; range A for a flange width of up to 180 mm is standard and covers approx. 80% of all applications. Conversion to range B for beam width up to 300 mm can be easily accomplished.
- The trolley wheels are designed for a max. beam profile incline of 14% (DIN 1025-part 1), excellent rolling features are guaranteed by pre-lubricated, encapsulated ball bearings.
- The low headroom version of the Yalelift IT is adjustable to fit a wide range of beam profiles (e.g. INP, IPE, IPB).
- Anti-drop and anti-tilt devices as standard.
- Excellent rolling features due to machined steel wheels mounted on pre-lubricated, encapsulated ball bearings.

Options

- Adjustable overload protection device.
- Chain container
- Rubber buffers
- Corrosion resistant version
- Beam locking device to secure the unloaded hoist with integrated trolley in a fixed position on the beam (park position e.g. on ships).

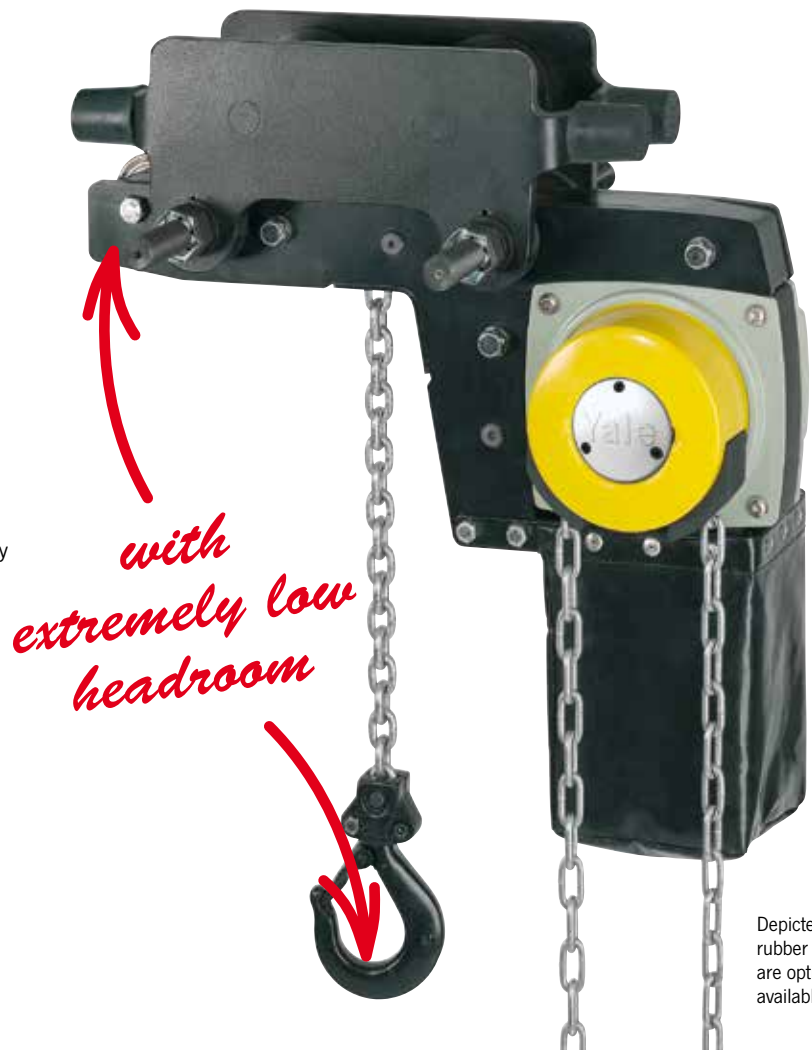

Depicted rubber buffers are optionally available!

360°

EXPERIENCE THE ADVANTAGE OF 360°



We are pleased to send you our new Atex catalogue in PDF format.

Technical data Yalelift LHP - with integrated push trolley

| Model | Art.-No. | Capacity in kg/ Number of chain falls | Size | Beam flange width b mm | Beam flange thickness t max. mm | Curve radius min. m | Weight at standard lift (3 m) kg |
|------------|-----------|--|------|------------------------------|---------------------------------------|---------------------------|--|
| YLLHP 500 | N05600017 | 500/1 | A | 60 - 180 | 19 | 0.9 | 27 |
| YLLHP 1000 | N05600018 | 1000/1 | A | 70 - 180 | 19 | 0.9 | 35 |
| YLLHP 2000 | N05600019 | 2000/1 | A | 82 - 180 | 19 | 1.15 | 61 |
| YLLHP 3000 | N05600020 | 3000/1 | A | 100 - 180 | 19 | 1.5 | 107 |
| YLLHP 5000 | N05600021 | 5000/2 | A | 110 - 180 | 27 | 2.0 | 152 |
| YLLHP 500 | - | 500/1 | B | 180 - 300 | 19 | 0.9 | 27 |
| YLLHP 1000 | - | 1000/1 | B | 180 - 300 | 19 | 0.9 | 36 |
| YLLHP 2000 | - | 2000/1 | B | 180 - 300 | 19 | 1.15 | 62 |
| YLLHP 3000 | - | 3000/1 | B | 180 - 300 | 19 | 1.4 | 109 |
| YLLHP 5000 | - | 5000/2 | B | 180 - 300 | 27 | 1.8 | 156 |

Technical data Yalelift LHG - with integrated geared trolley

| Model | Art.-No. | Capacity in kg/ Number of chain falls | Size | Beam flange width b mm | Beam flange thickness t max. mm | Curve radius min. m | Weight at standard lift (3 m) kg |
|-------------|-----------|--|------|------------------------------|---------------------------------------|---------------------------|--|
| YLLHG 500 | N05600022 | 500/1 | A | 60 - 180 | 19 | 0.9 | 31 |
| YLLHG 1000 | N05600023 | 1000/1 | A | 70 - 180 | 19 | 0.9 | 40 |
| YLLHG 2000 | N05600024 | 2000/1 | A | 82 - 180 | 19 | 1.15 | 65 |
| YLLHG 3000 | N05600025 | 3000/1 | A | 100 - 180 | 19 | 1.5 | 112 |
| YLLHG 5000 | N05600026 | 5000/2 | A | 110 - 180 | 27 | 2.0 | 157 |
| YLLHG 10000 | 192038865 | 10000/3 | A | 125 - 210 | 40 | 1.8 | 230 |
| YLLHG 500 | - | 500/1 | B | 180 - 300 | 19 | 0.9 | 32 |
| YLLHG 1000 | - | 1000/1 | B | 180 - 300 | 19 | 0.9 | 41 |
| YLLHG 2000 | - | 2000/1 | B | 180 - 300 | 19 | 1.15 | 67 |
| YLLHG 3000 | - | 3000/1 | B | 180 - 300 | 19 | 1.4 | 114 |
| YLLHG 5000 | - | 5000/2 | B | 180 - 300 | 27 | 1.8 | 161 |
| YLLHG 10000 | N05600027 | 10000/3 | B | 190 - 310 | 40 | 1.8 | 232 |

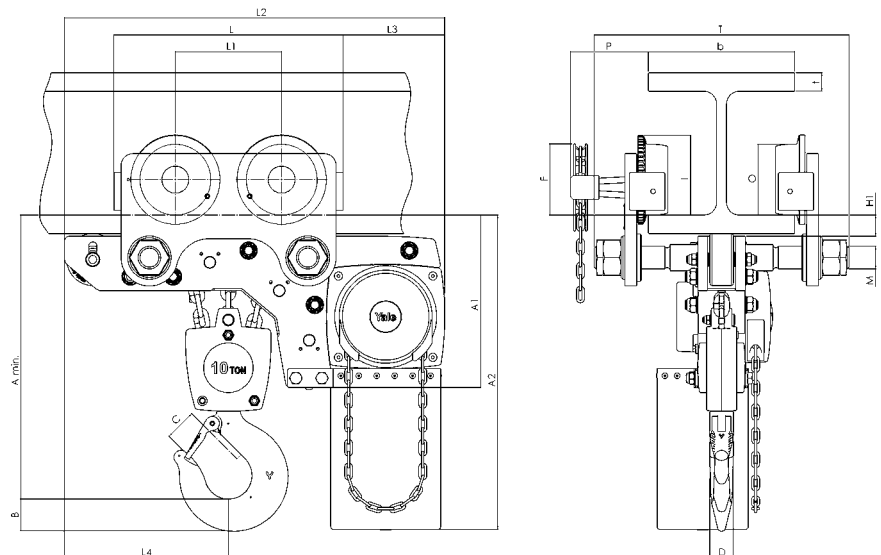

Yalelift LHG, 10000 kg, three falls

Dimensions Yalelift LH

| Model | YLLH 500 | YLLH 1000 | YLLH 2000 | YLLH 3000 | YLLH 5000 | YLLH 10000 |
|------------------------|----------|-----------|-----------|-----------|-----------|------------|
| A min., mm | 188 | 211 | 264 | 316 | 425 | 565 |
| A1, mm | 223 | 250 | 289 | 346 | 345 | 365 |
| A2, mm | 381 | 427 | 511 | 614 | 612 | 665 |
| B, mm | 17 | 22 | 30 | 38 | 45 | 68 |
| C, mm | 24 | 29 | 35 | 40 | 47 | 68 |
| D, mm | 14 | 19 | 22 | 30 | 37 | 50 |
| F (Geared trolley), mm | 92 | 92 | 91 | 107 | 150 | 150 |
| H1, mm | 24 | 24 | 24 | 32 | 31 | 45 |
| I (Push trolley), mm | 72 | 72 | 96 | 131 | 143 | - |
| I (Geared trolley), mm | 77 | 77 | 98 | 133 | 149 | 170 |
| L, mm | 270 | 310 | 360 | 445 | 525 | 485 |
| L1, mm | 130 | 130 | 150 | 180 | 209 | 225 |
| L2, mm | 444 | 488 | 582 | 690 | 720 | 805 |
| L3, mm | 124 | 135 | 172 | 203 | 175 | 215 |
| L4, mm | 184 | 201 | 230 | 265 | 283 | 348 |
| M, mm | M 18 | M 22 | M 27 | M 30 | M 42 | M 48 |
| O, mm | 60 | 60 | 80 | 112 | 125 | 150 |
| P (Geared trolley), mm | 108 | 110 | 112 | 112 | 117 | 165 |
| T (Area A), mm | 280 | 290 | 305 | 320 | 364 | 440 |
| T (Area B), mm | 400 | 410 | 425 | 440 | 484 | 540 |

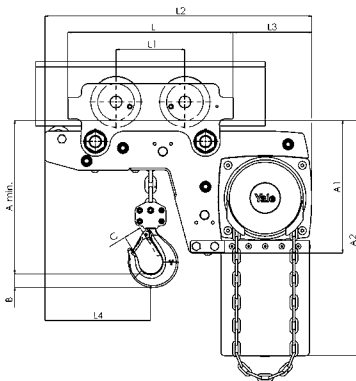

Yalelift LHP, 500 - 3000 kg, single fall

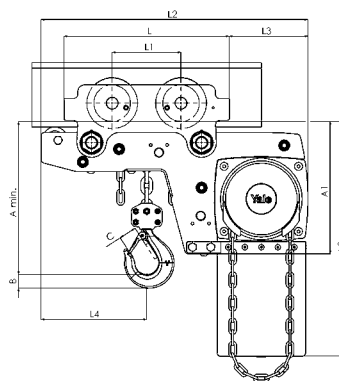
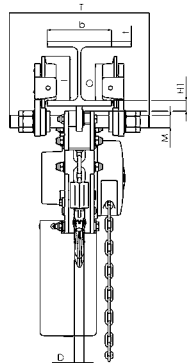

Yalelift LHG, 500 - 3000 kg, single fall

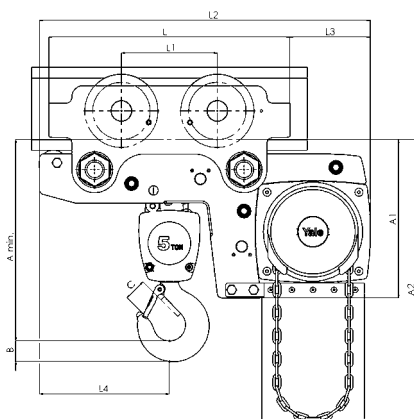
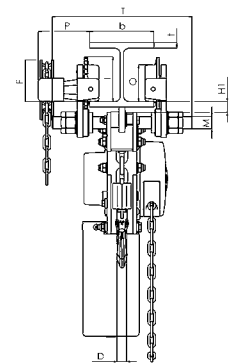

Yalelift LHP/LHG, 5000 kg, double fall

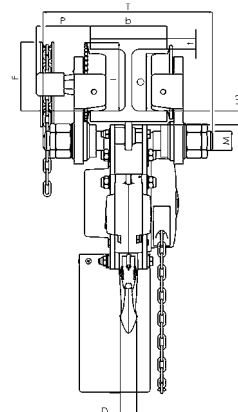
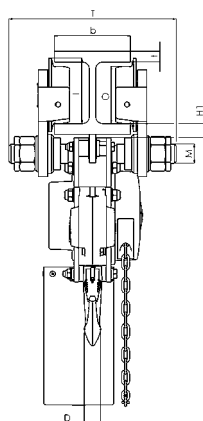

Yale **MINI 360** *new!*

Hand chain hoist

Capacity 250 - 500 kg

The smallest of the Yale hand chain hoists has a compact design and a hand chain wheel cover that allows a rotation of 360°. This ensures a high level of safety, as it is possible to work outside the danger zone.

The housing of the new Yale **MINI 360** is made of die-cast aluminium, which makes it a very lightweight hand chain hoist. Due to the low weight, there are countless possible applications, e.g. assembly work in industry, car repair shops, crafts etc.

Features

- With the 360° rotating hand chain guide, a very large work area can be covered, this makes it possible for the operator to stand clear of the danger zone.
- Compact design, light weight, easy to carry.
- Made of die-cast aluminium.
- Due to the compact housing, all internal parts are protected. The device can therefore also be used outdoors or in rough environments.
- The load pressure brake complies with all technical regulations, thus the load is held in any position.
- The standard equipment includes forged lifting and load hooks made from age-resistant high-alloy tempered steel, which open when overloaded without breaking. The hooks can be rotate through 360 degrees and are fitted with robust safety catches.
- The galvanized steel load chain complies with all applicable national and international regulations. The optimal fit to the load chain wheel ensures safe and long lasting operation.



So small - extremely useful!

360°

EXPERIENCE THE ADVANTAGE OF 360°



Due to its size, the Yale **MINI 360** fits into every tool box and supports the operator in his work.

Technical data Yale MINI 360

| Model | Art.-No. | Capacity kg | Number of chain falls | Chain dimensions d x p in mm/ design | Lift per 1 m hand chain overhaul mm | Handle pull at WLL daN | Weight at standard lift (3 m) kg |
|-------------------|-----------|----------------|--------------------------|---|--|------------------------------|---|
| Yale MINI 360 250 | 192084199 | 250 | 1 | 3 x 9 - T | 40 | 25 | 2.9 |
| Yale MINI 360 500 | 192084200 | 500 | 1 | 4 x 12 - T | 25 | 24 | 4.3 |

Dimensions Yale MINI 360

| Model | Yale MINI 360 250 | Yale MINI 360 500 |
|------------|-------------------|-------------------|
| A min., mm | 245 | 285 |
| B, mm | 17 | 22 |
| C, mm | 21 | 23 |
| D, mm | 13 | 18 |
| E, mm | 84 | 104 |
| F, mm | 87 | 101 |
| G, mm | 51 | 58 |
| H, mm | 36 | 43 |
| K, mm | 150 | 175 |

INFO

Yale hoists and trolleys are not designed for passenger elevation applications and must not be used for this purpose.

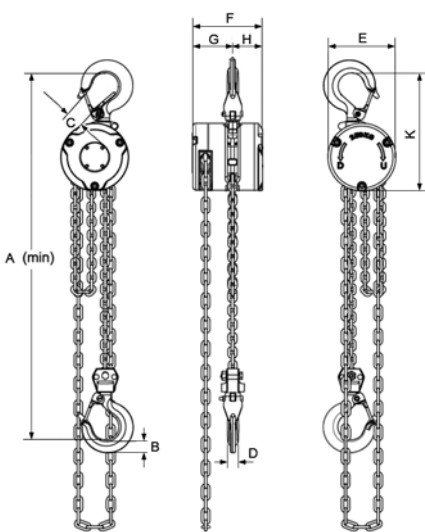

Capacity 250 kg

Capacity 500 kg



Lifting application



Pulling application



Corroded Yalelift with integrated trolley
– still functional after 9 years in use

Corrosion protection

What does corrosion actually mean?

Corrosion is a term from the Latin “corrodere” and means to decompose or eat away and is, from a technical point of view the reaction of a material with its environment. In popular speech, metals are also referred as “rusting”.

How does corrosion occur?

Nowadays, metals are exposed to a wide variety of environmental influences, such as climate and air pollution. This can change their structure. Especially with metals such as iron or steel, oxide formation has a negative effect on the material. Rust develops as a product of corrosion.

In untreated or damaged areas, humidity can hit the metal surface and thus attack it. The corresponding area begins to corrode to the point of rusting through completely.

Types of corrosion

Technically speaking, types of corrosion are classified according to material, cause and appearance and also according to where they occur.

The standard DIN EN ISO 8044 defines 37 different types of corrosion.

One of the best-known types of corrosion is contact corrosion, in which an electrochemical reaction between two different metallic materials in conjunction with e.g. humidity leads to corrosion of the less noble metal.

Other types of corrosion can be:

- pitting corrosion
- surface corrosion
- vibration corrosion cracking
- gap corrosion, etc.

Areas of application

Corrosion-protected equipment with galvanised load or hand chains or rust and acid-resistant chains should be used wherever increased demands are made on corrosion resistance are required. Typical applications are in the food industry (e.g. dairies, slaughterhouses, etc.), the chemical industry (e.g. paper industry, colouring), agriculture or wastewater treatment plants.



MKS coated hand chain hoist
Yalelift 360 with integrated trolley
and buffers.

This is the standard version with the classification Atex Basic. However, the unit can also be used in non-explosive areas without hesitation.

Preventive corrosion protection

To prevent early corrosion, all our products are coated. This coating varies depending on the model and is carried out in the form of a wet coating, powder or MKS coating.

For specifications on corrosion protection, the DIN EN ISO 12944 series of standards is used in many cases. This series of standards is used for steel structures or structures whose components are made of unalloyed or low-alloyed steel with a thickness of at least 3 mm and which are designed in accordance with a structural safety designed.

We can only base our products on the corrosivity categories contained in this series of standards (see table below). For some models, increased corrosion protection can be achieved by applying additional or thicker coatings. You will find a detailed list on the next page.

INFO

Corrosion causes annually in Germany alone 75 billion € damage!

Corrosion protection classes in accordance to DIN EN ISO 12944

| Atmospheric-Corrosivity categories, Corrosion stress | Corrosivity | Corrosion protection period | Protection period in years | Examples of typical environments |
|--|---|---|--|--|
| C1 very low | very low low-aggressive inside | short (L) medium (M) long (H) very long (VH) | up to 7 7 to 15 15 to 25 > 25 | Only indoor rooms, insulated buildings 60% relative humidity |
| C2 low | low moderate aggressive outside/inside | short (L) medium (M) long (H) very long (VH) | up to 7 7 to 15 15 to 25 > 25 | Slightly polluted atmosphere, dry climate, e.g. rural areas |
| C3 medium | moderate low-aggressive outside | short (L) medium (M) long (H) very long (VH) | up to 7 7 to 15 15 to 25 > 25 | City and industrial atmosphere with moderate SO ₂ pollution or moderate climate |
| C4 high | high moderately aggressive outside/inside | short (L) medium (M) long (H) very long (VH) | up to 7 7 to 15 15 to 25 > 25 | Industrial and coastal atmosphere with moderate salt pollution |
| C5 very high | very high aggressive outside/inside | short (L) medium (M) long (H) very long (VH) | up to 7 7 to 15 15 to 25 > 25 | Industrial atmosphere with high relative humidity and aggressive atmosphere as well as coastal atmosphere with high salt content |
| CX extremely | very high maritim outside/inside | short (L) medium (M) long (H) very long (VH) | up to 7 7 to 15 15 to 25 > 25 | Offshore areas with high salt content, industrial areas with extreme humidity and aggressive atmosphere as well as subtropical and tropical atmosphere |

MKS Coating

The MKS coating (micro corrosion protection system) is a coating of zinc and aluminium lamellae which primarily protect the unit against corrosion. Even thin layers - typically a system consisting of base and top coat - can achieve high protective effects against base metal corrosion (red rust).

This MKS coating is used on the models Yalelift 360 Atex and HTP/G Atex trolleys for use in explosion-protected areas, but also, for example in wastewater treatment plants.

Powder coating

This is a coating process in which a metal surface is coated with powder. A typical coating line consists of surface pre-treatment (cleaning and/or application of a conversion coating), intermediate drying, electrostatic coating zone and dryer. The workpieces are transported via a transport system. The powder coatings produced typically have layer thicknesses between 60 and 120 µm. However, depending on the application and surface characteristics, the coating thickness can also be above or below this range.

Wet painting

Varnish is a liquid coating material. This material is applied thinly to surfaces and built up into a continuous, solid film by chemical or physical processes (for example, evaporation of the solvent). Varnishes usually consist of binders such as resins, dispersions or emulsions, fillers, pigments, solvents and additives.

All three types of coating have the same purpose:

- **Protection**
(protective effect, such as protective coating with combination of primer and top coat, protective varnishes),
- **Decoration**
(optical effect, specific colour effect) and
- **Function**
(special surface properties, such as modified electrical conductivity)

Coating types as standard:

| Model | Coating type | | |
|---|--------------|----------------|-------------|
| | Wet painting | Powder coating | MKS Coating |
| CD 85 | + | | |
| Yalelift 360 | | ++ | |
| YL with integrated trolley ¹ | + | ++ | |
| HTP/G | + | | |
| CPE/CPA (with integrated trolley/Atex) | + | | |
| Yalelift 360 Atex | | | +++ |
| YL Atex with integrated trolley | | | +++ |
| HTP/HTG Atex | | | +++ |

¹Hand chain hoist powder coated/trolley wet painted

Additional coating possible for:

| Model | Coating type | | |
|---|--------------|----------------|----------------------|
| | Wet painting | Powder coating | MKS + Powder coating |
| CD 85 | x | | |
| Yalelift 360 | | x | |
| YL with integrated trolley ¹ | x | x | |
| HTP/G | x | | |
| CPE/CPA with integrated trolley/Atex | x | | |
| Yalelift 360 Atex | | | x |
| YL Atex with integrated trolley | | | x |
| HTP/HTG Atex | | | x |

¹Hand chain hoist powder coated/trolley wet painted

Selection criteria

The correct selection of an additional coating is essentially based on the following questions:

Where will the relevant equipment be used?

Chemical plants, refineries, off-/On-shore platforms etc.

What environmental stresses will the unit be exposed to?

This includes, for example, high humidity, industrial exhaust fumes, salty air, fluctuating temperature ranges, etc.

Layer thickness structure in general

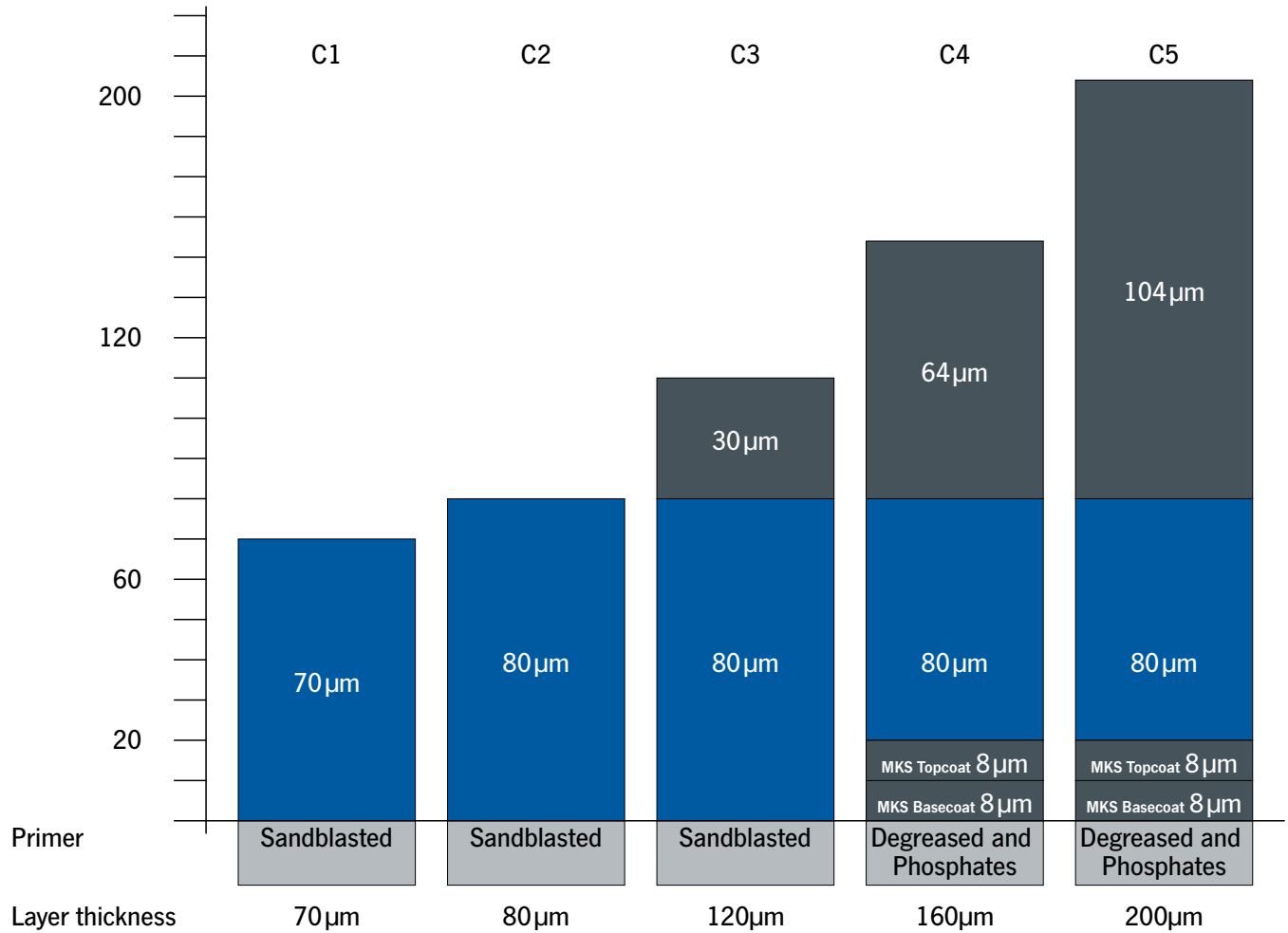

Up to C3 we cover all standard coatings (wet painting and powder coating) on our products. This means that the corrosivity categories C1 and C2 are also covered.

INFO

When measuring the coating thickness, slight deviations from the values given here are possible, depending on the measuring point.

A coating protocol can be prepared on request, at an additional charge.

Inspection points of dry film thickness (DFT)

Order No.: _____

Model: _____

Serial No.: _____

Tag No.: _____

Note:
The dimensional unit for all specified measured values is µm!

P = Powder coating
N = Wet paint coating
MP = Measure Point

Date: _____

Sign: _____



YC Beam clamp

Capacity 1000 - 10000 kg

Provides a quick and versatile rigging point for hoisting equipment, pulley blocks or loads. Flexible application due to wide adjustment range. The central threaded spindle allows easy attachment and a safe and secure grip.

The spindle can be secured against loosening.

INFO

Yale hoists and trolleys are not designed for passenger elevation applications and must not be used for this purpose.

Useable as a horizontal rigging point.

Also applicable as lifting clamp..

Technical data YC

| Model | Art.-No. | Capacity kg | Beam flange width mm | Weight kg |
|-------|-----------|-------------|----------------------|-----------|
| YC 1 | NO5406181 | 1000 | 75 - 230 | 3.4 |
| YC 2 | NO5406182 | 2000 | 75 - 230 | 3.8 |
| YC 3 | NO5407417 | 3000 | 80 - 320 | 7.6 |
| YC 5 | NO5407418 | 5000 | 90 - 320 | 11.0 |
| YC 10 | NO5407419 | 10000 | 90 - 320 | 17.2 |

Dimensions YC

| Model | YC 1 | YC 2 | YC 3 | YC 5 | YC 10 |
|------------|------|------|------|------|-------|
| A min., mm | 115 | 115 | 180 | 180 | 175 |
| A max., mm | 150 | 150 | 225 | 225 | 220 |
| A1, mm | 78 | 78 | 85 | 95 | 95 |
| A2, mm | 246 | 246 | 325 | 325 | 325 |
| B1, mm | 186 | 186 | 232 | 242 | 268 |
| B2, mm | 350 | 350 | 455 | 445 | 480 |
| b1, mm | 75 | 75 | 80 | 90 | 90 |
| b2, mm | 230 | 230 | 320 | 320 | 320 |
| C, mm | 50 | 50 | 70 | 70 | 70 |
| D, mm | 3 | 4 | 6 | 10 | 14 |
| E, mm | 215 | 215 | 255 | 255 | 275 |
| F1, mm | 34 | 35 | 35 | 35 | 35 |
| F2, mm | 17 | 18 | 21 | 21 | 20 |
| G1, mm | 82 | 82 | 120 | 116 | 110 |
| G2, mm | 44 | 44 | 75 | 75 | 66 |
| H, mm | 20 | 20 | 22 | 28 | 38 |
| J1, mm | 14 | 14 | 30 | 30 | 34 |
| J2, mm | 21 | 21 | 34 | 34 | 35 |
| K1, mm | 48 | 50 | 60 | 60 | 60 |
| K2, mm | 31 | 32 | 40 | 42 | 40 |
| L, mm | 80 | 86 | 114 | 129 | 146 |

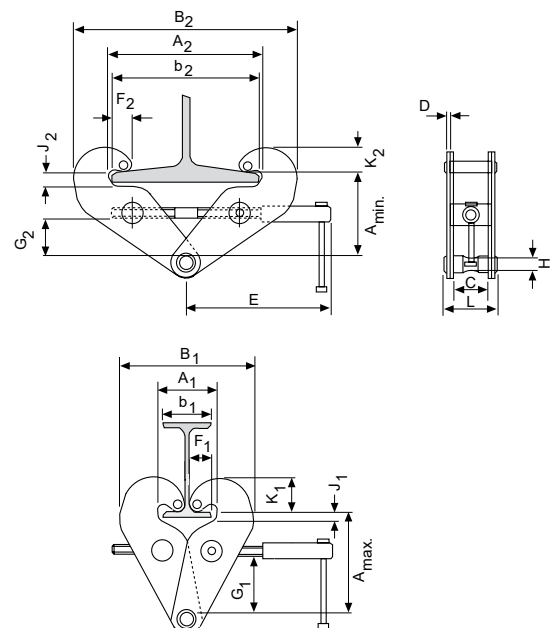

CTP Trolley clamp

Capacity 1000 - 3000 kg

Easy fitting to overhead beams for the attachment and transport of loads.

Features

- Central threaded spindle provides quick adjustment to the required beam width.
- Threaded spindle and clevis are zinc-plated for added corrosion protection.



Technical data CTP

| Model | Art.-No. | Capacity kg | Beam flange width b mm | Curve radius min. m | Weight kg |
|---------|-----------|----------------|------------------------------|---------------------------|--------------|
| CTP 1-A | N05500024 | 1000 | 60 - 150 | 0.6 | 2.5 |
| CTP 2-A | N05500025 | 2000 | 75 - 200 | 0.9 | 9.9 |
| CTP 2-B | N05500026 | 2000 | 200 - 300 | 0.9 | 10.3 |
| CTP 3-A | N05500027 | 3000 | 75 - 200 | 1.15 | 17.5 |
| CTP 3-B | N05500028 | 3000 | 200 - 320 | 1.15 | 19.5 |

Dimensions CTP

| Model | CTP 1-A | CTP 2-A | CTP 2-B | CTP 3-A | CTP 3-B |
|-----------|----------|-----------|-----------|-----------|-----------|
| A, mm | 82 - 109 | 106 - 155 | 136 - 191 | 128 - 171 | 150 - 212 |
| D, mm | 26 | 42 | 42 | 50 | 50 |
| E, mm | 22 | 20 | 20 | 22 | 22 |
| H1, mm | 20 | 24 | 24 | 30.5 | 30.5 |
| I, mm | 53 | 71.5 | 71.5 | 95.5 | 95.5 |
| L, mm | 160 | 260 | 260 | 310 | 310 |
| L1, mm | 75 | 130 | 130 | 150 | 150 |
| M, mm | M12 | M18 | M18 | M24 | M24 |
| O, mm | 46 | 60 | 60 | 80 | 80 |
| P, mm | 153 | 205 | 255 | 220 | 280 |
| T, mm | 105 | 139 | 189 | 155 | 215 |
| tmax., mm | 15 | 25 | 25 | 25 | 25 |

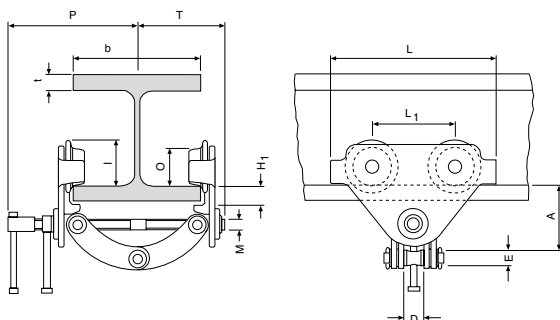

INFO

Yale hoists and trolleys are not designed for passenger elevation applications and must not be used for this purpose.



HTP (Push trolley)



HTG (Geared trolley)

HTP and HTG Push and geared trolley

Capacity 500 - 50000 kg

The trolley enables the exact positioning or easy traversing of large loads with either manual or powered hoisting equipment.

Features

- It has excellent rolling features due to machined steel wheels mounted on prelubricated, encapsulated ball bearings.
- Adjustable to fit a wide range of beam widths and profiles (e.g. INP, IPE and IPB).
- Adjustments are made by rotating the clevis load bar which also ensures the centred positioning of the hoist in the clevis – no creeping to the left or the right (up to 5000 kg capacity, from 8000 kg upwards the traverse is adjusted via sleeves and washers).
- The trolley wheels are designed for a max. beam profile incline of 14% (DIN 1025 - part 1).

Options

up to 20000 kg capacity:

- Rotating hand chain guide.
- Stainless steel hand chains.
- Locking device to secure the trolley in position on the beam (park position e.g. on ships).
- Corrosion resistant version.

all capacities:

- Buffers

SERIES EXTENSION
NOW WITH HIGH WWL!
30000 - 50000 kg

INFO

Yale hoists and trolleys are not designed for passenger elevation applications and must not be used for this purpose.

Technical data HTP

| Model | Art.-No. | Capacity kg | Size | Beam flange width b mm | Beam flange thickness t max. mm | Curve radius min. m | Hand effort at WLL daN | Weight kg | Weight with locking device kg |
|----------|-----------|----------------|------|---------------------------------|--|---------------------------|------------------------------|--------------|--|
| HTP 500 | N05141273 | 500 | A | 50 - 220 | 25 | 0.9 | - | 8.0 | 14.5 |
| HTP 1000 | N05141274 | 1000 | A | 50 - 220 | 25 | 0.9 | - | 9.0 | 17.0 |
| HTP 2000 | N05141275 | 2000 | A | 66 - 220 | 25 | 1.15 | - | 16.0 | 24.0 |
| HTP 3000 | N05141276 | 3000 | A | 74 - 220 | 25 | 1.4 | - | 32.0 | 41.2 |
| HTP 5000 | N05141277 | 5000 | A | 90 - 220 | 25 | 1.8 | - | 48.0 | 58.5 |
| HTP 500 | N05148305 | 500 | B | 160 - 300 | 40 | 0.9 | - | 10.6 | 17.1 |
| HTP 1000 | N05148306 | 1000 | B | 160 - 300 | 40 | 0.9 | - | 12.0 | 20.0 |
| HTP 2000 | N05148307 | 2000 | B | 160 - 300 | 40 | 1.15 | - | 19.3 | 27.3 |
| HTP 3000 | N05148308 | 3000 | B | 160 - 300 | 40 | 1.4 | - | 35.8 | 45.0 |
| HTP 5000 | N05148309 | 5000 | B | 180 - 300 | 40 | 1.8 | - | 52.2 | 62.7 |

Technical data HTG

| Model | Art.-No. | Capacity kg | Size | Beam flange width b mm | Beam flange thickness t max. mm | Curve radius min. m | Hand effort at WLL daN | Weight ¹ kg | Weight ¹ with locking device kg |
|-----------|-----------|----------------|------|---------------------------------|--|---------------------------|------------------------------|---------------------------|---|
| HTG 500 | N05300006 | 500 | A | 50 - 220 | 25 | 0.9 | 3 | 97 | 16.2 |
| HTG 1000 | N05300007 | 1000 | A | 50 - 220 | 25 | 0.9 | 6 | 11.2 | 19.2 |
| HTG 2000 | N05300008 | 2000 | A | 66 - 220 | 25 | 1.15 | 7 | 18.0 | 26.0 |
| HTG 3000 | N05300009 | 3000 | A | 74 - 220 | 25 | 1.4 | 7 | 35.4 | 44.6 |
| HTG 5000 | N05300010 | 5000 | A | 90 - 220 | 25 | 1.8 | 9 | 51.8 | 62.3 |
| HTG 500 | N05300011 | 500 | B | 160 - 300 | 40 | 0.9 | 3 | 12.6 | 19.1 |
| HTG 1000 | N05300012 | 1000 | B | 160 - 300 | 40 | 0.9 | 6 | 14.1 | 22.1 |
| HTG 2000 | N05300013 | 2000 | B | 160 - 300 | 40 | 1.15 | 7 | 21.3 | 29.3 |
| HTG 3000 | N05300014 | 3000 | B | 160 - 300 | 40 | 1.4 | 7 | 39.2 | 48.4 |
| HTG 5000 | N05300015 | 5000 | B | 180 - 300 | 40 | 1.8 | 9 | 56.0 | 66.5 |
| HTG 8000 | N05300016 | 8000 | B | 125 - 310 | 40 | 1.8 | 14 | 104.0 | - |
| HTG 10000 | N05300017 | 10000 | B | 125 - 310 | 40 | 1.8 | 14 | 104.0 | - |
| HTG 15000 | N05300018 | 15000 | B | 125 - 310 | 40 | 5.0 | 29 | 230.0 | - |
| HTG 20000 | N05300019 | 20000 | B | 125 - 310 | 40 | 5.0 | 29 | 230.0 | - |
| HTG 30000 | 192045613 | 30000 | B | 175 - 305 | 34 | 1.6 | 24 | 248.0 | - |
| HTG 50000 | 192045614 | 50000 | B | 175 - 305 | 34 | 5.1 | 25 | 489.0 | - |

¹Weight HTG: without hand chain



We are pleased to send you our new Atex catalogue in PDF format.

Hoisting Equipment Trolleys

Dimensions HTP

| Model | HTP 500-A | HTP 1000-A | HTP 2000-A | HTP 3000-A | HTP 5000-A | HTP 500-B | HTP 1000-B | HTP 2000-B | HTP 3000-B | HTP 5000-B |
|-------------|-----------|------------|------------|------------|------------|-----------|------------|------------|------------|------------|
| A, mm | 77 | 82.5 | 98.5 | 114 | 132.5 | 92 | 97.5 | 113.5 | 129 | 147.5 |
| D, mm | 16 | 17 | 22 | 26 | 33 | 16 | 17 | 22 | 26 | 33 |
| D1, mm | 25 | 30 | 40 | 48 | 60 | 25 | 30 | 40 | 48 | 60 |
| D2, mm | 30 | 35 | 47 | 58 | 70 | 30 | 35 | 47 | 58 | 70 |
| F1, mm | 57.5 | 57.5 | 57.5 | 57.5 | 57.5 | 57.5 | 57.5 | 57.5 | 57.5 | 57.5 |
| H1, mm | 30.5 | 30.5 | 30.5 | 30 | 30 | 45.5 | 45.5 | 45.5 | 45 | 49.5 |
| I (HTP), mm | 71.5 | 71.5 | 95.5 | 131 | 142.5 | 71.5 | 71.5 | 95.5 | 131 | 142.5 |
| L, mm | 260 | 260 | 310 | 390 | 450 | 260 | 260 | 310 | 390 | 450 |
| L1, mm | 130 | 130 | 150 | 180 | 209 | 130 | 130 | 150 | 180 | 209 |
| O, mm | 60 | 60 | 80 | 112 | 125 | 60 | 60 | 80 | 112 | 125 |
| P1, mm | 168 | 168 | 168 | 168 | 168 | 168 | 168 | 168 | 168 | 168 |
| P2, mm | 146 | 150 | 155 | 160 | 167.5 | 177 | 177 | 177 | 180 | 187.5 |
| L3, mm | 346 | 346 | 396 | 476 | 556 | 346 | 346 | 396 | 476 | 556 |

Dimensions HTG

| Model | HTG 500-A | HTG 1000-A | HTG 2000-A | HTG 3000-A | HTG 5000-A | HTG 500-B | HTG 1000-B | HTG 2000-B | HTG 3000-B | HTG 5000-B |
|-------------|-----------|------------|------------|------------|------------|-----------|------------|------------|------------|------------|
| A, mm | 77 | 82.5 | 98.5 | 114 | 132.5 | 92 | 97.5 | 113.5 | 129 | 147.5 |
| D, mm | 16 | 17 | 22 | 26 | 33 | 16 | 17 | 22 | 26 | 33 |
| D1, mm | 25 | 30 | 40 | 48 | 60 | 25 | 30 | 40 | 48 | 60 |
| D2, mm | 30 | 35 | 47 | 58 | 70 | 30 | 35 | 47 | 58 | 70 |
| F (HTG), mm | 91.5 | 91.5 | 90.5 | 107.5 | 149.5 | 91.5 | 91.5 | 90.5 | 107.5 | 149.5 |
| F1, mm | 57.5 | 57.5 | 57.5 | 57.5 | 57.5 | 57.5 | 57.5 | 57.5 | 57.5 | 57.5 |
| H1, mm | 30.5 | 30.5 | 30.5 | 30 | 30 | 45.5 | 45.5 | 45.5 | 45 | 45 |
| I (HTG), mm | 76.5 | 76.5 | 98 | 132.5 | 148.5 | 76.5 | 76.5 | 98 | 132.5 | 148.5 |
| L, mm | 260 | 260 | 310 | 390 | 450 | 260 | 260 | 310 | 390 | 450 |
| L1, mm | 130 | 130 | 150 | 180 | 209 | 130 | 130 | 150 | 180 | 209 |
| O, mm | 60 | 60 | 80 | 112 | 125 | 60 | 60 | 80 | 112 | 125 |
| P (HTG), mm | 110 | 110 | 110 | 110 | 110 | 110 | 110 | 110 | 110 | 110 |
| P1, mm | 168 | 168 | 168 | 168 | 168 | 168 | 168 | 168 | 168 | 168 |
| P2, mm | 146 | 150 | 155 | 160 | 167.5 | 187 | 187 | 189.5 | 191.5 | 191.5 |
| L3, mm | 346 | 346 | 396 | 476 | 556 | 346 | 346 | 396 | 476 | 556 |
| P3, mm | 194 | 194 | 194 | 195 | 195 | 194 | 194 | 194 | 195 | 195 |

Dimensions HTG

| Model | HTG 8000-B | HTG 10000-B | HTG 15000-B | HTG 20000-B | HTG 30000-B | HTG 50000-B |
|-------------|------------|-------------|-------------|-------------|-------------|-------------|
| A, mm | 276 | 276 | 270 | 270 | 261 | 310 |
| B, mm | 52 | 52 | 70 | 70 | 65 | 100 |
| D, mm | 30 | 30 | 35 | 35 | 35 | 60 |
| D1, mm | 80 | 80 | 110 | 110 | 90 | 125 |
| D2, mm | 114 | 114 | 155 | 155 | 125 | 195 |
| F (HTG), mm | 113 | 113 | 113 | 113 | 93 | 93 |
| F1, mm | 77 | 77 | - | - | - | - |
| H1, mm | 45 | 45 | 45 | 45 | 40 | 40 |
| I (HTG), mm | 170 | 170 | 170 | 170 | 224 | 224 |
| L, mm | 430 | 430 | 870 | 870 | 625 | 1.260 |
| L1, mm | 200 | 200 | 200 | 200 | 296 | 296 |
| L2, mm | - | - | 115 | 115 | 164.5 | 164.5 |
| O, mm | 150 | 150 | 150 | 150 | 196 | 196 |
| P (HTG), mm | 163 | 163 | 163 | 163 | 165 | 165 |
| P1, mm | 193 | 193 | - | - | - | - |
| T, mm | 270 | 270 | 270 | 270 | 333 | 343 |
| L3, mm | 536 | 536 | 976 | 976 | - | - |

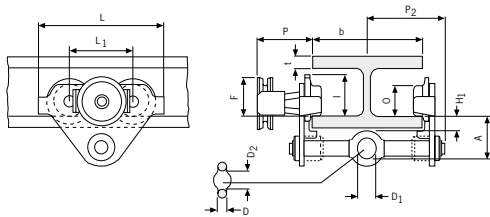

HTP/G, 500 - 5000 kg

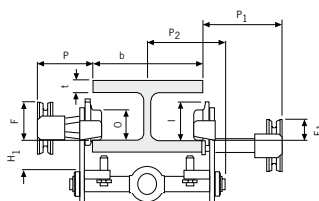

HTP/G, 500 - 5000 kg,
with locking device

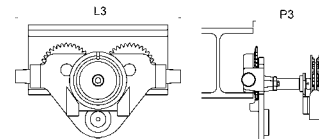

HTG, 500 - 5000 kg,
with rotating hand chain guide
and buffers

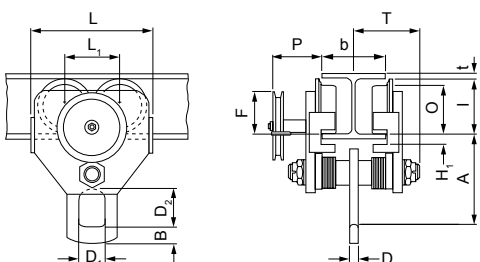

HTG, 10000 kg

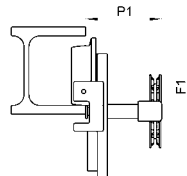

HTG, 10000 kg,
with locking device

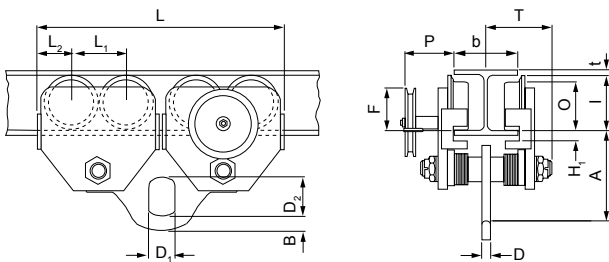

HTG, 15000 - 20000 kg

SERIES EXTENSION
NOW WITH HIGH WWL!
30000 - 50000 kg

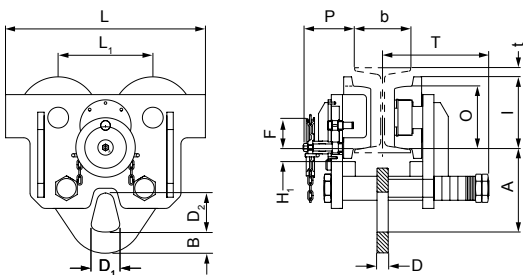

HTG, 30000 kg

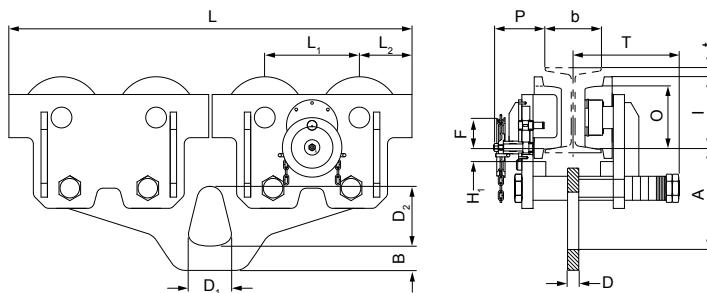

HTG, 50000 kg



VTE-U, VTEF-U Electric trolley with shackle

Capacity 1000 - 5000 kg

Specially recommended for loads over 1000 kg, for transporting over long distances and/or when used frequently.

Suitable for almost all hoists with suspension hook due to universal shackle connection.

Travel motor with worm gear transmission ensures smooth start and self braking – a separate motor brake is not required.

Features

- Standard operating voltage:
Euro-voltage 400V, 3-phase, 50 Hz.
Single speed motors can be reconnected to 230V, 3-phase, 50 Hz.
- Motor protected to IP55 against dust and water jets.
Push-button pendant control IP65.
- Compact, robust frame with low overall height.
- Wheels manufactured from fracture-proof steel. Smooth running due to machined surfaces and ball bearing mounting. Cambered profile suitable for flat and inclined beam profiles.
- Anti-drop and anti-tilt devices as standard.
- Easy adjusted to fit to a wide range of beam widths and profiles due to threaded spindles.

Options

- Low voltage control (42V)
- Rubber buffers
- 230V, 1-phase, 50 Hz



Wheel with cambered profile



Threaded spindle



Anti-drop device with option to fit buffers.

INFO

Yale hoists and trolleys are not designed for passenger elevation applications and must not be used for this purpose.

Technical data VTE-U, VTEF-U

| Model | Art.-No. | Capacity | Travel speed | Motor | Beam flange width A ² | Beam flange thickness t max. | Curve radius min. at flange width A / B ² | Weight at flange width A / B ² |
|--------------------------------|-----------|----------|---------------------|-----------|----------------------------------|------------------------------|--|---|
| | | kg | m/min | kW | mm | mm | m | kg |
| VTE 1-A-18/U ¹ | N06409625 | 1000 | 18 ¹ | 0.18 | 58 - 180 | 19 | 0.9/0.9 | 19.5/25.2 |
| VTEF 1-A-18/4,5/U ¹ | N06409943 | 1000 | 18/4.5 ¹ | 0.18/0.06 | 58 - 180 | 19 | 0.9/0.9 | 19.5/25.2 |
| VTE 2-A-18/U ¹ | N06409626 | 2000 | 18 ¹ | 0.18 | 58 - 180 | 19 | 1.15/1.15 | 26/30.2 |
| VTEF 2-A-18/4,5/U ¹ | N06409945 | 2000 | 18/4.5 ¹ | 0.18/0.06 | 58 - 180 | 19 | 1.15/1.15 | 26/30.2 |
| VTE 3-A-11/U | N06409939 | 3000 | 11 | 0.37 | 74 - 180 | 27 | 1.5/1.4 | 51/53 |
| VTEF 3-A-11/2,8/U | N06409947 | 3000 | 11/2.8 | 0.3/0.09 | 74 - 180 | 27 | 1.5/1.4 | 51/53 |
| VTE 5-A-11/U | N06409941 | 5000 | 11 | 0.37 | 98 - 180 | 27 | 2.0/1.8 | 77/80 |
| VTEF 5-A-11/2,8/U | N06409949 | 5000 | 11/2.8 | 0.3/0.09 | 98 - 180 | 27 | 2.0/1.8 | 77/80 |

¹11 or 11/2.8m/min. travel speed on request

²Trolleys with beam flange width B are suitable for flange width of 180 - 300 mm

Dimensions VTE-U, VTEF-U

| Model | VTE 1-A-18/U | VTE 2-A-18/U | VTE 3-A-11/U | VTE 5-A-11/U |
|---------|----------------------|----------------------|----------------------|----------------------|
| A, mm | 113 | 115 | 139 | 161 |
| B, mm | b + 50 | b + 54 | b + 60 | b + 70 |
| C, mm | 49 | 47 | 57 | 60 |
| D, mm | 16 | 16 | 19 | 22 |
| E, mm | 187 | 187 | 202 | 202 |
| F, mm | 94 | 94 | 94 | 94 |
| G, mm | 43 | 43 | 51 | 58 |
| H, mm | 129 | 128 | 144 | 178 |
| H1, mm | 24 | 24 | 32 | 32 |
| I, mm | 77 | 98 | 133 | 149 |
| L1, mm | 130 | 150 | 180 | 209 |
| M, mm | 155 | 180 | 208 | 263 |
| N1G, mm | 255 | 255 | 292 | 292 |
| N2G, mm | 263 | 263 | 296 | 296 |
| O, mm | 60 | 80 | 112 | 125 |
| P, mm | 123 | 123 | 129 | 121 |
| Q, mm | 145/205 ³ | 153/213 ³ | 160/220 ³ | 182/242 ³ |

³at beam flange width B

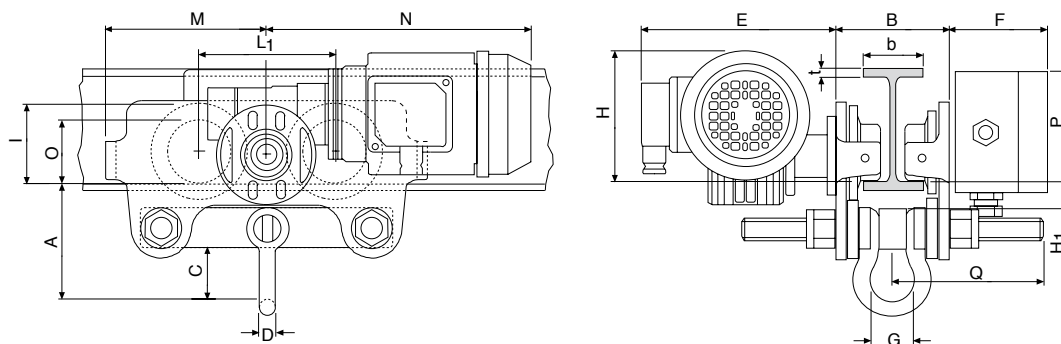



General information about electric chain hoists

Apart from the usual criterion such as lifting capacity, lifting speed and dimensions also consider following:

1. Choosing a motor according to FEM 9.683

In addition to the torque the decisive criterion for rating an electric motor is the heat it generates. Here we differentiate between two operational modes:

1.1 Intermittent duty

In this case the motor is designed for a series of equal cycles consisting of duty periods with constant load and rest periods. The heat generation depends on the relative duty cycle, that is, the relationship between operating period under load, total operating time and the number of starts/hour.

$$ED = \frac{\text{Operating period}}{\text{Operating period} + \text{rest periods}} \%$$

The number of cycles that can be made under full load is calculated as follows:

$$S \approx 0.3 \times \frac{ED \times V}{H}$$

- S = Cycles per hour
- ED = Duty rating in %
- V = Lifting speed in m/min
- H = Average lifting height in m

A cycle consists of a motion of lifting, lowering and the rest periods. One must ensure that the lifting height does not exceed the value permitted by the percentage duty cycle referred to a cycle period of 10 minutes

$$H \leq \frac{ED \times V}{20}$$

and that simultaneously the permissible number of starts is not exceeded. It is generally accepted that a cycle consists of 6 starts.

1.2 Short time duty

Where special duty conditions exist (e.g. long hook path) the operating period must be of such length that the admissible temperature limit of the motor is not exceeded. For such cases intermittent duty must be replaced by short time duty. That is, the motor may be operated for up to 10 starts over a certain period (with Yale products 30 min). Thereafter the motor must cool down to room temperature.

1.3 Calculation example intermittant duty

| | | |
|----------------------|---|---------|
| Electric chain hoist | : | CPV 5-8 |
| Lifting speed | : | 8 m/min |
| Lifting height | : | 2,8 m |
| Duty rating ED | : | 50 % |
| c/h | : | 180 |

Number of cycles per hour

$$S = 0.3 \times \frac{50 \times 8}{2.8} = 42.8$$

Max. lifting height

$$H = 2.8 \leq \frac{50 \times 8}{20} = 20 \text{ m}$$

Number of starts

$$N = \frac{25 \text{ cycles}}{\text{hour}} \times \frac{6 \text{ starts}}{\text{cycle}} = 150 \text{ c/h}$$

2. Classification of hoisting equipment according to FEM 9.511

To choose an optimal hoist the lifting capacity and also the classification group must be known. The classification group indicates the theoretical operating time of the mechanical components under full load:

| | | | | | |
|----------------------|-----|------|------|------|------|
| Classification group | FEM | 1 Bm | 1 Am | 2 m | 3 m |
| | ISO | M3 | M4 | M5 | M6 |
| Operating time in h | | 400 | 800 | 1600 | 3200 |

If the hoist is operated as classified an actual operating time of around 10 years can be expected. After this period a general overhaul is necessary.

To define the classification group following values must be determined:

2.1 Average operating time per day

The average operating time can be estimated or calculated as follows:

$$\text{Operating time/day} = \frac{2 \times \text{average hook path} \times \text{cycles/hour} \times \text{operating time/day}}{60 \times \text{lifting speed}}$$

2.2 Load spectrum

The load spectrum indicates to what extent a hoist or part thereof is subject to maximal stress or whether it is subject to smaller loads only. It can be calculated or estimated according to the diagrams on the right:

1 light
Hoists or parts thereof usually subject to very small loads and in exceptional cases only to maximum loads.

2 medium
Hoists or parts thereof usually subject to small loads but rather often to maximum loads.

3 heavy
Hoists or parts thereof usually subject to medium loads but frequently to maximum loads.

4 very heavy
Hoists or parts thereof usually subject to maximum or almost maximum loads.



2.3 Classification

The classification group is defined by operating hours and load spectrum:

| Load spectrum | Aver. op. hours per working day | | |
|--------------------------------------|---------------------------------|----------|--------|
| 1 light | up to 2 | 2-4 | 4-8 |
| 2 medium | up to 1 | 1-2 | 2-4 |
| 3 heavy | up to 0.5 | 0.5-1 | 1-2 |
| 4 very heavy | up to 0.25 | 0.25-0.5 | 0.5-1 |
| Classification group acc. to FEM/ISO | 1 Bm/M3 | 1 Am/M4 | 2 m/M5 |



Motor surface cooled

| Protection | 1 st digit | | 2 nd digit |
|------------|-------------------------------------|--|--------------------------------|
| | Contact protection | Ingress of solid foreign particles | Ingress of liquid |
| IP 44 | contact with tools or similar | against solid foreign bodies over 1 mm Ø | splashing from all directions |
| IP 50 | complete protection against contact | damaging dust deposits | no protection |
| IP 54 | contact with tools or similar | against solid foreign bodies over 1 mm Ø | splashing from all directions |
| IP 55 | complete protection against contact | damaging dust deposits | water jets from all directions |
| IP 56 | complete protection against contact | damaging dust deposits | momentarily flooding |
| IP 65 | complete protection against contact | against ingress of dust | water jets from all directions |

IP protection according to EN 60529

Depending on the operating and environmental conditions the damaging effect of water, foreign particles and dust and the contact with live or moving parts inside a motor is to be prevented by choosing a suitable protection.

The marking used to indicate the degree of protection consists of the letters IP followed by two characteristic numerals.

The marking applies to the unit as it is supplied and the defined or usual location of the unit.

The protection can change if the unit is located or fitted differently.

Protection against contact and solid foreign particles

First digit 0 No protection

No protection of persons against contact with live or moving parts inside the enclosure. No protection of equipment against ingress of solid foreign particles.

First digit 1 Protection against large solid foreign particles

Protection against accidental or inadvertent contact with live or moving parts inside the enclosure by a large surface of the human body, e.g. hand, but not protected against deliberate access to such parts.

First digit 2 Protection against med. size solid foreign particles

Protection against contact with live or moving parts inside the enclosure by fingers. Protection against ingress of medium size solid foreign particles of diameter greater than 12 mm.

First digit 3 Protection against small solid foreign particles

Protection against contact with live or moving parts inside the enclosure by tools, wires or such objects of thickness greater than 2.5 mm. Protection against ingress of small solid foreign particles of diameter greater than 2.5 mm.

First digit 4 Protection against granular structured foreign particles

Protection against contact with live or moving parts inside the enclosure by tools, wires or such objects of thickness greater than 1 mm. Protection against ingress of granular structured solid foreign particles of diameter greater than 1 mm.

First digit 5 Protection against dust deposits

Complete protection against contact with live or moving parts inside the enclosure. Protection against harmful deposits of dust. The ingress of dust is not totally prevented, but dust cannot enter in an amount sufficient to interfere with the satisfactory operation of the equipment enclosed.

First digit 6 Complete protection

Complete protection against contact with live or moving parts inside the enclosure. Protected against the ingress of dust.

Protection against liquids

Second digit 0 No protection

No particular protection

Second digit 1 Protection against vertical water drops

Droplets of condensed water falling on the enclosure shall have no harmful effects.

Second digit 2 Protection against diagonal falling water drops

Protection against dripping liquids. Droplets of falling liquid shall have no harmful effect when the enclosure is tilted at any angle up to 15° from the vertical.

Second digit 3 Protection against spray water

Protection against dripping liquids. Water falling as rain at an angle equal to or smaller than 60° in respect to the vertical shall have no harmful effect.

Second digit 4 Protection against splashing

Liquid splashed from any direction shall have no harmful effect.

Second digit 5 Protection against water jets

Water projected by a nozzle from any direction under stated conditions shall have no harmful effect.

Second digit 6 Protection against flooding

Protection against conditions on ships decks (deck watertight equipment). Water from heavy seas shall not enter the enclosure under prescribed conditions².

Second digit 7 Protection against immersion in water

It shall not be possible for water to enter the enclosure under stated conditions of pressure and time².

Second digit 8 Protection against indefinite immersion

Protection against indefinite immersion in water.

Under specific pressure it shall not be possible for water to enter the enclosure²).

²) In certain cases water should not ingress. As required this is defined on the follow-on page of the unit in question.

Technical questionnaire to identify a suitable electric chain hoist

Company: _____ Date: _____
 Contact: _____ e-Mail: _____
 Phone: _____ Fax: _____

Details about intended use

Required capacity

Lifting height

Ambient conditions

Normal
 Humidity
 Dust
 Dirt
 Particular temperatures _____ °C
 Increased rel. humidity _____ %
 Other _____

How long is the hoist in operation

_____ Load cycles per hour
 _____ Hours per day
 _____ Days per week
 _____ Distance covered per lifting cycle

Unusual operating conditions that could be important for the choice and function of the electric chain hoist:

Type of load

Permanent
 Changing
 Shocks
 Vibration
 Static

Trolley drive

Motor
 Manual

Operating voltage

400 V
 230 V
 3-phase a.c.
 1-phase a.c.

Power frequency

50 Hz
 60 Hz

Protection

IP 54
 Other

Hook suspension

Other



Yale **CPV**

Electric chain hoist with suspension hook or with integrated trolley

Capacity 125 - 5000 kg

The electric chain hoist CPV combines modern design and technical innovation. A robust construction makes the series a versatile tool for professional applications.

The integrated limit switch for the highest and lowest hook position considerably extends the working life span of the slip clutch, motor and gearbox.

Features

- Increased operating safety through 42V control voltage (low voltage control) and the main contactor.
- The integrated limit switch for the highest and lowest hook position considerably extends the service life of the slip clutch, motor and gearbox.
- Overload protection (slip clutch) in all CPV hoists is outside force flow to meet higher safety requirements.
- Electromagnetic spring pressure brake holds the load safely even in the event of power failure.
- Different suspension types available such as top hook, lug or an integrated trolley. A retro-fit to another type of suspension is possible.
- Any chain length (lifting height) as per customer order.
- Oil bath gearbox (or semifluid grease with CPV/F 2-8 and 5-4 as well as CPV 2-4 and 5-2) with helical gearing for particularly smooth service and enhanced lifetime.
- All-steel chain guide.
- The chain guide of the smallest hoist CPV/F 2-8 and 5-4 as well as CPV 2-4 and 5-2 is a thermoplastic (POM) chain guide that is integral with the housing.
- CPV series are protected up to IP 55.
- 2 year warranty (excluding wear parts) and a lifetime lubricated gearbox.

COMPLETE SERIES CPV
**CAPACITIES
125-5000 KG**
WITH
**SUSPENSION HOOK
AS STANDARD,
SUSPENSION LUG AS AN OPTION,
PUSH, GEARED OR
ELECTRIC TROLLEY**

INFO

Festooned cable systems please see pages 146-147.

Yale hoists and trolleys are not designed for passenger elevation applications and must not be used for this purpose.

Options

- Other operating and control voltages.
- Flexible chain containers
- Power supply cables, CEE plugs with phase changing switch.
- Radio remote controls, also acc. to EN 13849-1 PL “d” and “e”.
- Pluggable control pendants.
- Wall mounted controls.
- Rotary limit switch as a back-up to standard limit switches.
- Frequency controllers, stepless and ramp controls.
- Suspensions 90° turned.
- Thermal sensors.



Optional:
Radio remote control



Optional:
with suspension lug

Yale CPV

Further standards

CPV

“Quick Delivery” programme

Capacity 250 - 1000 kg

Features

- Top hook suspension
- Lifting height 6 m
- With chain container

SPECIAL MODEL CPV
“QUICK DELIVERY”
THE HOIST CAN BE SHIPPED
EX CMCO WUPPERTAL
WITHIN 24 HOURS

Technical data CPVF - 24 h “Quick Delivery” programme

| Model | Art.-No. | Capacity kg | Number of chain falls | Lifting speed in m/min | |
|-----------|-----------|-------------|-----------------------|------------------------|-----------|
| | | | | main lift | fine lift |
| CPVF 2-8 | 192052434 | 250 | 1 | 8 | 2 |
| CPVF 5-8 | 192052435 | 500 | 1 | 8 | 2 |
| CPVF 10-8 | 192052436 | 1000 | 1 | 8 | 2 |

CPV... DC

with direct control

Capacity 125 - 500 kg

Features

- Suspension hook as standard
- With overload protection, without limit switches
- With chain container

Technical data CPV... DC - 400V, 3 phase, 50Hz

| Model | Art.-No. | Capacity kg | Number of chain falls | Lifting speed m/min |
|------------|-----------|-------------|-----------------------|---------------------|
| CPV 1-8 DC | 192059040 | 125 | 1 | 8 |
| CPV 2-8 DC | 192059042 | 250 | 1 | 8 |
| CPV 5-4 DC | 192059043 | 500 | 2 | 4 |

Hoisting Equipment Electric chain hoists

Technical data CPV/CPVF - 400V, 3 phase, 50 Hz

| Capacity kg | Model | Number of chain falls | Chain dimensions d x p mm | Classification FEM/ISO | Lifting speed | | Hoist motor kW | Motor rating ED % | Weight at standard lift (3 m) ¹ | | |
|----------------|-----------|--------------------------------|------------------------------------|-------------------------------|--------------------|--------------------|--------------------------|-----------------------------|--|------------------------------------|--|
| | | | | | main lift m/min | fine lift m/min | | | suspension lug kg | push trolley ² kg | electric trolley ³ kg |
| 125 | CPV 2-8 | 1 | 4 x 12.2 | 3 m/M6 | 8 | – | 0.37 | 75 | 17 | 26 | 31 |
| 125 | CPVF 2-8 | 1 | 4 x 12.2 | 3 m/M6 | 8 | 2 | 0.37/0.09 | 50/25 | 18 | 27 | 32 |
| 250 | CPV 2-8 | 1 | 4 x 12.2 | 1 Am/M4 | 8 | – | 0.37 | 50 | 17 | 26 | 31 |
| 250 | CPVF 2-8 | 1 | 4 x 12.2 | 1 Am/M4 | 8 | 2 | 0.37/0.09 | 33/17 | 18 | 27 | 32 |
| 250 | CPVF 2-18 | 1 | 5 x 15.1 | 1 Am/M4 | 18 | 4.5 | 0.75/0.18 | 33/17 | 27 | 42 | 50 |
| 320 | CPV 5-8 | 1 | 5 x 15.1 | 3 m/M6 | 8 | – | 0.75 | 67 | 26 | 41 | 49 |
| 320 | CPVF 5-8 | 1 | 5 x 15.1 | 3 m/M6 | 8 | 2 | 0.75/0.18 | 45/22 | 27 | 42 | 50 |
| 500 | CPV 5-4 | 2 | 4 x 12.2 | 1 Am/M4 | 4 | – | 0.37 | 50 | 20 | 29 | 34 |
| 500 | CPVF 5-4 | 2 | 4 x 12.2 | 1 Am/M4 | 4 | 1 | 0.37/0.09 | 33/17 | 21 | 30 | 35 |
| 500 | CPV 5-8 | 1 | 5 x 15.1 | 1 Am/M4 | 8 | – | 0.75 | 50 | 26 | 41 | 49 |
| 500 | CPVF 5-8 | 1 | 5 x 15.1 | 1 Am/M4 | 8 | 2 | 0.75/0.18 | 33/17 | 27 | 42 | 50 |
| 500 | CPVF 5-18 | 1 | 7.1 x 20.5 | 1 Am/M4 | 18 | 4.5 | 1.5/0.37 | 33/17 | 59 | 78 | 85 |
| 630 | CPV 10-8 | 1 | 7.1 x 20.5 | 3 m/M6 | 8 | – | 1.5 | 67 | 58 | 77 | 84 |
| 630 | CPVF 10-8 | 1 | 7.1 x 20.5 | 3 m/M6 | 8 | 2 | 1.5/0.37 | 45/22 | 59 | 78 | 85 |
| 1000 | CPV 10-4 | 2 | 5 x 15.1 | 1 Am/M4 | 4 | – | 0.75 | 50 | 28 | 43 | 51 |
| 1000 | CPVF 10-4 | 2 | 5 x 15.1 | 1 Am/M4 | 4 | 1 | 0.75/0.18 | 33/17 | 29 | 44 | 52 |
| 1000 | CPV 10-8 | 1 | 7.1 x 20.5 | 1 Am/M4 | 8 | – | 1.5 | 50 | 58 | 77 | 84 |
| 1000 | CPVF 10-8 | 1 | 7.1 x 20.5 | 1 Am/M4 | 8 | 2 | 1.5/0.37 | 33/17 | 59 | 78 | 85 |
| 1500 | CPV 20-4 | 2 | 7.1 x 20.5 | 2 m/M5 | 4 | – | 1.5 | 62 | 63 | 82 | 89 |
| 1500 | CPVF 20-4 | 2 | 7.1 x 20.5 | 2 m/M5 | 4 | 1 | 1.5/0.37 | 41/21 | 64 | 83 | 90 |
| 2000 | CPV 20-4 | 2 | 7.1 x 20.5 | 1 Am/M4 | 4 | – | 1.5 | 50 | 63 | 82 | 89 |
| 2000 | CPVF 20-4 | 2 | 7.1 x 20.5 | 1 Am/M4 | 4 | 1 | 1.5/0.37 | 33/17 | 64 | 83 | 90 |
| 2000 | CPVF 25-8 | 1 | 11.3 x 31 | 2 m/M5 | 8 | 2 | 3.6/0.9 | 39/20 | 85 | 147 | 161 |
| 2500 | CPVF 25-8 | 1 | 11.3 x 31 | 1 Am/M4 | 8 | 2 | 3.6/0.9 | 33/17 | 85 | 147 | 161 |
| 3200 | CPVF 50-4 | 2 | 11.3 x 31 | 3 m/M6 | 4 | 1 | 3.6/0.9 | 44/22 | 98 | 160 | 174 |
| 5000 | CPVF 50-4 | 2 | 11.3 x 31 | 1 Am/M4 | 4 | 1 | 3.6/0.9 | 33/17 | 98 | 160 | 174 |

CPV - 230V, 1 PH, 50 HZ

| | | | | | | | | |
|------|------------|---|------------|---------|---|---|------|----|
| 125 | CPV 2-4 | 1 | 4 x 12.2 | 3 m/M6 | 4 | – | 0.37 | 35 |
| 250 | CPV 2-4 | 1 | 4 x 12.2 | 1 Bm/M3 | 4 | – | 0.37 | 25 |
| 500 | CPV 5-2 | 2 | 4 x 12.2 | 1 Bm/M3 | 2 | – | 0.37 | 25 |
| 500 | CPV 5-8 | 1 | 5 x 15.1 | 1 Bm/M3 | 8 | – | 1.0 | 25 |
| 1000 | CPV 10-4 | 2 | 5 x 15.1 | 1 Bm/M3 | 4 | – | 1.0 | 25 |
| 1000 | CPV 10-4/1 | 1 | 7.1 x 20.5 | 1 Bm/M3 | 4 | – | 0.75 | 25 |
| 2000 | CPV 20-2 | 2 | 7.1 x 20.5 | 1 Bm/M3 | 2 | – | 0.75 | 25 |

¹Other lifting heights on request. ²For trolleys type A and B: Additional weight for geared trolley (VTG): 2.5 kg

³For electric trolley with 2 speeds (VTEF) +2.0 kg



Depicted chain container optionally available.

Trolleys

| Suitable for | Capacity of the trolley kg | Size | All trolleys | | | Electric trolley | |
|---|----------------------------|------|------------------------|---------------------------------|---------------------|-----------------------------|-------------------|
| | | | Beam flange width b mm | Beam flange thickness t max. mm | Curve radius min. m | travel speed m/min at 50 Hz | motor kW at 50 Hz |
| CPV/CPVF 2-8/5-4, CPV2-4/5-2 | 500 | A | 58 - 180 | 19 | 0.9 | 11 or 18 | 0.09 |
| CPV/CPVF 2-8/5-4, CPV2-4/5-2 | 500 | B | 180 - 300 | 19 | 0.9 | 11 or 18 | 0.09 |
| CPV/CPVF 5-8/10-4, CPVF 2-18 | 1000 | A | 58 - 180 | 19 | 0.9 | 18 or 18/4.5 ¹ | 0.18 or 0.18/0.06 |
| CPV/CPVF 5-8/10-4, CPVF 2-18 | 1000 | B | 180 - 300 | 19 | 0.9 | 18 or 18/4.5 ¹ | 0.18 or 0.18/0.06 |
| CPV/CPVF 10-8/20-4, CPVF 5-18, CPV 10-4/1, 20-2 | 2000 | A | 58 - 180 | 19 | 1.15 | 18 or 18/4.5 ¹ | 0.18 or 0.18/0.06 |
| CPV/CPVF 10-8/20-4, CPVF 5-18, CPV 10-4/1, 20-2 | 2000 | B | 180 - 300 | 19 | 1.15 | 18 or 18/4.5 ¹ | 0.18 or 0.18/0.06 |
| CPVF 25-8/50-4 | 5000 | A | 98 - 180 | 27 | 2.0 | 11 or 11/2.8 | 0.37 or 0.3/0.09 |
| CPVF 25-8/50-4 | 5000 | B | 180 - 300 | 27 | 1.8 | 11 or 11/2.8 | 0.37 or 0.3/0.09 |

¹Alternatively 11 or 11/2.8 m/min

Yale CPV

Options and features for applications

FOR CORROSIVE ENVIRONMENT & FOOD INDUSTRY

- Stainless steel load chains.
- Stainless steel load hooks for single fall hoists.
- Zinc- or copper- bottom blocks for double fall hoists.
- Zinc plated trolleys and/or 2-component topcoat.
- Food industry approved gearbox lubricants and grease (H1).
- Textile rain coats for hoists and trolleys.



FOR SIMULTANEOUS LIFTING

Yale offers solutions for lifting loads with two or more electric chain hoists simultaneously. Depending on the customer's application, the hoist system must meet various and sometimes very demanding requirements.

- Radio or cable controls.
- Movement selection: single or group movement.
- On trolleys or as point hoists.
- Coupled trolleys.

Please contact Columbus McKinnon to find a suitable solution.

FOR STATIONARY LOADS ABOVE PERSONS

Columbus McKinnon offers Yale electric chain hoists designed for holding stationary loads above persons in accordance with the EN 14492-2:2019.

We implement these increased safety requirements in our models CPV...DB, offering load capacities from 125 kg to 1000 kg.

FOR CRANE BUILDING

- Beam locking device for trolleys.
- Rubber buffers for trolleys.
- Trolley travel end buffer stops.
- 90° suspension on trolley.
- Counter for operating hours.
- Trolley travel end limit switches.
- Signal horn or lamp for crane applications.
- Festoon cable systems or other power supply.
- Suspensions for light crane systems.
- Crane operation pendants.

FOR WIND ENERGY

- Chain lengths up to 200 m.
- Electric chain hoists with high lifting speed.
- Chain containers for longer chains and with special suspensions.
- Increased corrosion-resistance.
- Special suspensions.
- Load hooks with protective cover.



| Model | Art.-No. | Capacity kg | Number of chain falls | Lifting speed m/min |
|-------------|-----------|----------------|--------------------------|------------------------|
| CPV 2-8 DB | 192054103 | 125 | 1 | 8 |
| CPV 5-4 DB | 192054104 | 250 | 2 | 4 |
| CPV 5-8 DB | 192054105 | 250 | 1 | 8 |
| CPV 10-4 DB | 192054107 | 500 | 2 | 4 |
| CPV 10-8 DB | 192054108 | 500 | 1 | 8 |
| CPV 20-4 DB | 192054109 | 1000 | 2 | 4 |

Dimensions CPV/CPVF

| Model | CPV/CPVF 2-8 CPV 2-4 | CPV/CPVF 5-4 CPV 5-2 | CPVF 2-18 CPV/CPVF 5-8 | CPV/CPVF 10-4 | CPVF 5-18 CPV/CPVF 10-8 CPV 10-4/1 | CPV/CPVF 20-4 CPV 20-2 | CPVF 25-8 | CPVF 50-4 |
|---|-------------------------|-------------------------|---------------------------|---------------|--|---------------------------|------------|------------|
| A, mm | 327 | 363 | 357 | 430 | 431 | 528 | 514 | 658 |
| A1, mm | 163 | 163 | 196 | 196 | 234 | 234 | 288 | 288 |
| A2 (dimension with chain container), mm | | | | | | | | |
| -Size I (for lift-height, m) | 343 (15 m) | 343 (7.5 m) | 476 (10 m) | 476 (5 m) | 564 (12 m) | 564 (6 m) | 580 (13 m) | 580 (6 m) |
| -Size II (for lift-height, m) | 413 (32 m) | 413 (16 m) | 526 (22 m) | 526 (11 m) | 644 (18 m) | 644 (9 m) | 764 (25 m) | 764 (12 m) |
| -Size III (for lift-height, m) | 483 (52 m) | 483 (26 m) | 606 (40 m) | 606 (20 m) | 734 (25 m) | 734 (12 m) | 854 (30 m) | 854 (15 m) |
| -Size IV (for lift-height, m) | - | - | 798 (64 m) | 798 (32 m) | 934 (40 m) | 934 (20 m) | - | - |
| B, mm | 23 | 23 | 22 | 29 | 29 | 37 | 37 | 37 |
| B1, mm | 12 | 12 | 15 | 15 | 20 | 20 | 33 | 33 |
| C, mm | 30 | 30 | 29 | 35 | 35 | 40 | 46 | 46 |
| C1, mm | 30 | 30 | 38 | 38 | 45 | 45 | 71 | 71 |
| C2, mm | 105 | 105 | 105 | 105 | 154 | 154 | 194 | 194 |
| D, mm | 16 | 16 | 15 | 21 | 21 | 26 | 35 | 35 |
| D1, mm | 12 | 12 | 15 | 15 | 15 | 15 | 25 | 25 |
| E, mm | 205 | 205 | 277 | 277 | 326 | 326 | 409 | 409 |
| G, mm | 106 | 126 | 120 | 144 | 140 | 173 | 179 | 179 |
| G1 (size I), mm | 124 | 124 | 142 | 166 | 175 | 208 | 264 | 264 |
| G1 (size II), mm | 124 | 124 | 162 | 186 | 175 | 208 | 264 | 264 |
| G1 (size III), mm | 124 | 124 | 162 | 186 | 175 | 208 | 265 | 265 |
| G1 (size IV), mm | 124 | 124 | 162 | 186 | 175 | 208 | - | - |
| H, mm | 99 | 79 | 157 | 133 | 186 | 154 | 230 | 230 |
| H2, mm | 92 | 72 | 158 | 158 | 186 | 186 | 230 | 180 |
| K, mm | 215 | 215 | 208 | 208 | 285 | 285 | 335 | 335 |
| M (size I), mm | 157 | 157 | 162 | 162 | 209 | 209 | 300 | 300 |
| M (size II), mm | 157 | 157 | 197 | 197 | 209 | 209 | 300 | 300 |
| M (size III), mm | 157 | 157 | 197 | 197 | 209 | 209 | 301 | 301 |
| M (size IV), mm | 157 | 157 | 197 | 197 | 209 | 209 | - | - |
| N ¹ , mm | 159 | 159 | 219 | 219 | 274 | 274 | 299 | 299 |

¹for 230V, 1-phase, 50 Hz: approx. +35 mm

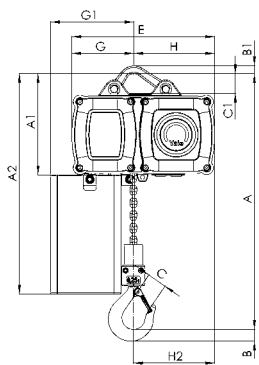

CPV/CPVF
with suspension lug, 125 - 2500 kg, single fall

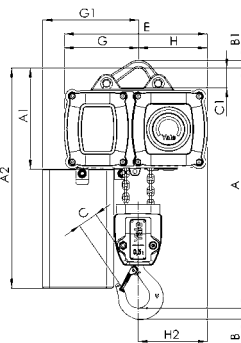
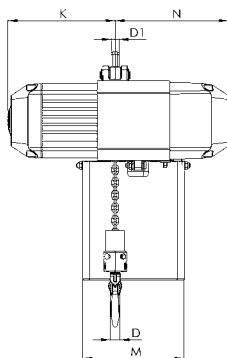

CPV/CPVF
with suspension lug, 500 - 5000 kg, double fall

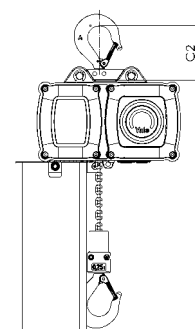
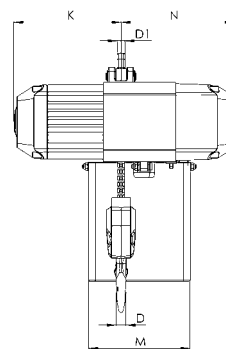

CPV/CPVF
suspension hook, 250 - 2500 kg

Dimensions CPV/CPVF

| Model | CPV/CPVF 2-8 CPV 2-4 | CPV/CPVF 5-4 CPV 5-2 | CPVF 2-18 CPV/CPVF 5-8 | CPV/CPVF 10-4 | CPVF 5-18 CPV/CPVF 10-8 CPV 10-4/1 | CPV/CPVF 20-4 CPV 20-2 | CPVF 25-8 | CPVF 50-4 |
|---|-------------------------------|-------------------------------|-------------------------------|-------------------------------|--|-------------------------------|-------------------------------|-------------------------------|
| A3, mm | 199 | 199 | 228 | 228 | 263 | 263 | 339 | 339 |
| A4 (dimension with chain container), mm | | | | | | | | |
| -Size I (for lift-height, m) | 379 (15 m) | 379 (7.5 m) | 508 (10 m) | 508 (5 m) | 593 (12 m) | 593 (6 m) | 631 (13 m) | 631 (6 m) |
| -Size II (for lift-height, m) | 449 (32 m) | 449 (16 m) | 558 (22 m) | 558 (11 m) | 673 (18 m) | 673 (9 m) | 815 (25 m) | 815 (12 m) |
| -Size III (for lift-height, m) | 519 (52 m) | 519 (26 m) | 638 (40 m) | 638 (20 m) | 768 (25 m) | 768 (12 m) | 905 (30 m) | 905 (15 m) |
| -Size IV (for lift-height, m) | - | - | 830 (64 m) | 830 (32 m) | 968 (40 m) | 968 (20 m) | - | - |
| A5, mm | 365 | 401 | 389 | 462 | 460 | 558 | 648 | 738 |
| b, mm | A = 58 - 180 B = 180 - 300 | A = 58 - 180 B = 180 - 300 | A = 58 - 180 B = 180 - 300 | A = 58 - 180 B = 180 - 300 | A = 58 - 180 B = 180 - 300 | A = 58 - 180 B = 180 - 300 | A = 98 - 180 B = 180 - 300 | A = 98 - 180 B = 180 - 300 |
| H1, mm | 25 | 25 | 24 | 24 | 23 | 23 | 30 | 30 |
| H3, mm | 113 | 113 | 129 | 129 | 129 | 129 | 178 | 178 |
| H4 (VTG), mm | 95 | 95 | 95 | 95 | 95 | 95 | 149 | 149 |
| H4 (VTE), mm | 142 | 142 | 142 | 142 | 142 | 142 | 121 | 121 |
| I (Push trolley), mm | 72 | 72 | 72 | 72 | 96 | 96 | 142 | 142 |
| I (Geared trolley), mm | 76 | 76 | 77 | 77 | 98 | 98 | 149 | 149 |
| L (VTP/VTG), mm | 310 | 310 | 310 | 310 | 360 | 360 | 525 | 525 |
| L1, mm | 130 | 130 | 130 | 130 | 150 | 150 | 209 | 209 |
| L2 (VTE), mm | 255 | 255 | 255 | 255 | 255 | 255 | 292 | 292 |
| L2 (VTEF), mm | 222 | 222 | 263 | 263 | 263 | 263 | 296 | 296 |
| L3, mm | 135 | 135 | 155 | 155 | 180 | 180 | 263 | 263 |
| L4, mm | 131 | 111 | 173 | 161 | 203 | 203 | 258 | 208 |
| O, mm | 60 | 60 | 60 | 60 | 80 | 80 | 125 | 125 |
| P, mm | 171 | 171 | 180 | 180 | 180 | 180 | 172 | 172 |
| P1, mm | 236 | 236 | 246 | 246 | 246 | 246 | 233 | 233 |
| S, mm | b + 50 | b + 50 | b + 50 | b + 50 | b + 54 | b + 54 | b + 70 | b + 70 |
| T, mm | 94 | 94 | 94 | 94 | 94 | 94 | 94 | 94 |
| tmax., mm | 12 | 12 | 19 | 19 | 19 | 19 | 27 | 27 |

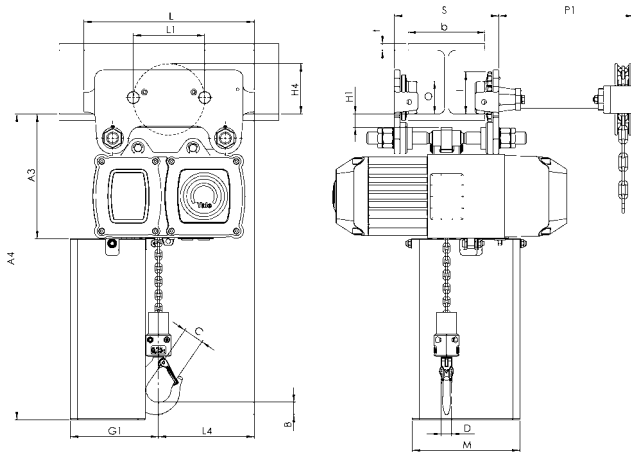

CPV/CPVF with integrated manual push or geared trolley

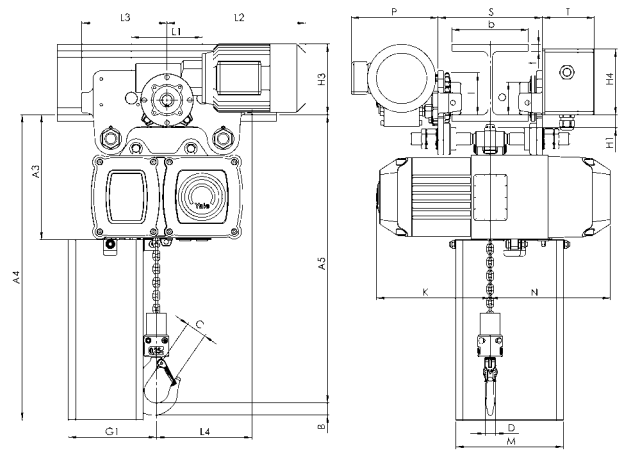

CPV/CPVF with integrated electric trolley



The delivered product may differ from the product shown in the image.

CPEF Electric chain hoist with V or with integrated trolley

Capacity 1600 - 7500 kg

The CPEF series is a range of high quality products for professional applications. They are highly efficient and engineered for a long working life. The hoists are composed of three main component parts which makes service easy and inexpensive.

Features

- Classification 1 Am/M4, except CPEF 20-8, CPEF 30-5 und CPEF 40-4 with classification 1 Bm/M3.
 - 42V low voltage control.
 - 2 year warranty (excluding wear parts) as well as a lifetime lubricated gear box.
 - Motor fitted with a bimetallic thermal protection
 - Duty cycle 40 % at one operating speed.
 - The heavy duty squirrel cage motor has an adjustable spring pressure brake that holds the load secure even in the event of a power failure.
 - Standard operating voltage: Euro-voltage 400V, 3-phase, 50 Hz.
 - Motor protected to IP 54, insulation class F.
 - Encapsulated pendant control protected to IP 65, against ingress of dust and water jets.
 - The 5-pocket load chain sheave, manufactured from wear resistant case hardening steel, is matched perfectly to the load chain to guarantee smooth and precise chain motion.
 - The standard, oil bath lubricated planetary gearbox is particularly smooth running.
 - Forged suspension and load hooks are made from non-aging, high tensile steel and fitted with robust safety latches.
 - The standard case hardened and zinc-plated link chain is matched perfectly to the load chain to guarantee smooth and precise chain motion.
- All requirements of national and international standards and regulations are fulfilled.

Options

- Stainless steel load chain.
- Suspension hook rotated 90°.
- Flexible chain container.
- Other operating voltages.
- Limit switches for highest and lowest hook positions (in combination with low voltage control).
- Radio remote control.
- Control for synchronized operation of several hoists.
- Manual and electric trolleys.
- Festooned cable system or conductor rail system.

CPEF 100-2
Electric chain hoist
with suspension hook or with
integrated trolley

Capacity 10000 kg

The model CPEF 100-2 consists of two CPEF 50-2 units. They are connected by a framework. Hook suspension, geared or electric trolleys are available. Integrated limit switches for highest and lowest hook positions are standard. 42V low voltage control as standard.

Options

- Stainless steel load chain.
- Flexible chain container.
- Other operating voltages.
- Motor with stainless steel brake.
- Radio remote control.
- Festooned cable system or conductor rail system.

INFO

The units are certified by the employer's liability insurance association (Berufsgenossenschaft) and fulfil the requirements of the machinery directive 2006/42/EG.

Festooned cable systems please see pages 146-147.



The delivered product may differ from the product shown in the image.



5-pocket load chain sheave machined for smooth, precise chain motion.



Universal connection to suspension hook, trolley or steel structures.



Double fall bottom block for capacities between 3200 up to 5000 kg.



Hoist connected directly to trolley with electric drive. Manual pull and geared trolleys also available.



Option: Flexible chain container made from wear resistant textile fabric.



lowest hook dimension A only **516 mm**
up to CPEF 30-5

compact planetary gearbox

zinc-plated Yale load chain

push-button pendant control, IP 65

Technical data CPEF - 400V, 3 phase, 50 Hz

| Model | Art.-No. CPEF with hook suspension | Capacity in kg/ Number of chain falls | Chain dimensions d x p mm | Classification FEM/ISO | Lifting speed | | Hoist motor kW | Motor rating ED % |
|-------------|---|--|------------------------------------|-------------------------------|--------------------|--------------------|--------------------------|-----------------------------|
| | | | | | main lift m/min | fine lift m/min | | |
| CPEF 16-8 | N06000246 | 1600/1 | 11 x 31 | 1Am/M4 | 8 | 2 | 2.3/0.58 | 40/20 |
| CPEF 20-8 | N06000248 | 2000/1 | 11 x 31 | 1Bm/M3 | 8 | 2 | 2.8/0.7 | 25/15 |
| CPEF 25-5 | N06000250 | 2500/1 | 11 x 31 | 1Am/M4 | 5 | 1.25 | 2.3/0.58 | 40/20 |
| CPEF 30-5 | N06000252 | 3000/1 | 11 x 31 | 1Bm/M3 | 5 | 1.25 | 2.8/0.7 | 25/15 |
| CPEF 32-4 | N06000254 | 3200/2 | 11 x 31 | 1Am/M4 | 4 | 1 | 2.3/0.58 | 40/20 |
| CPEF 40-4 | N06000256 | 4000/2 | 11 x 31 | 1Bm/M3 | 4 | 1 | 2.8/0.7 | 25/15 |
| CPEF 50-2 | N06000258 | 5000/2 | 11 x 31 | 1Am/M4 | 2.5 | 0.6 | 2.3/0.58 | 40/20 |
| CPEF 75-1,6 | N06000278 | 7500/3 | 11 x 31 | 1Am/M4 | 1.6 | 0.4 | 2.8/0.58 | 40/20 |
| CPEF 100-2 | N06041607 | 10000/4 | 11 x 31 | 1Am/M4 | 2.5 | 0.6 | 2 x 2.3/0.58 | 40/20 |

| Model | Weight at standard lift (3m) ¹ | | |
|-------------|---|--------------------------------|---------------------------|
| | suspension hook kg | manual geared trolley kg | electric trolley kg |
| CPEF 16-8 | 93 | 159 | 171 |
| CPEF 20-8 | 93 | 159 | 171 |
| CPEF 25-5 | 93 | 159 | 171 |
| CPEF 30-5 | 93 | 159 | 171 |
| CPEF 32-4 | 112 | 178 | 189 |
| CPEF 40-4 | 112 | 178 | 189 |
| CPEF 50-2 | 112 | 178 | 189 |
| CPEF 75-1,6 | 226 | 326 | 348 |
| CPEF 100-2 | 287 | 390 | 413 |

¹Other lifting heights on request.

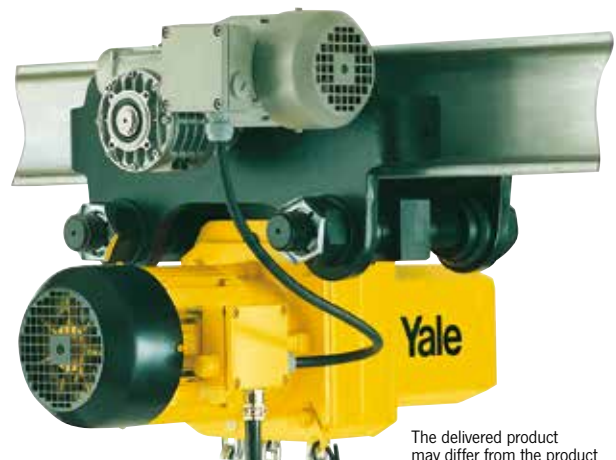

The delivered product may differ from the product shown in the image.

Technical data trolleys

| Capacity kg | Size | Beam flange width b mm | Beam flange thickness t max. mm | Curve radius min. m | Electric trolley travel speed m/min at 50 Hz | Electric trolley motor kW at 50 Hz |
|----------------|------|---------------------------------|--|---------------------------|---|---|
| 1600 - 5000 | A | 98 - 180 | 27 | 2.0 | 11/2.8 | 0.3/0.09 |
| 1600 - 5000 | B | 180 - 300 | 27 | 1.8 | 11/2.8 | 0.3/0.09 |
| 7500 - 10000 | B | 125 - 310 | 40 | 1.8 | 5/1.25 | 0.55/0.12 |

INFO

Festooned cable systems please see pages 146-147.

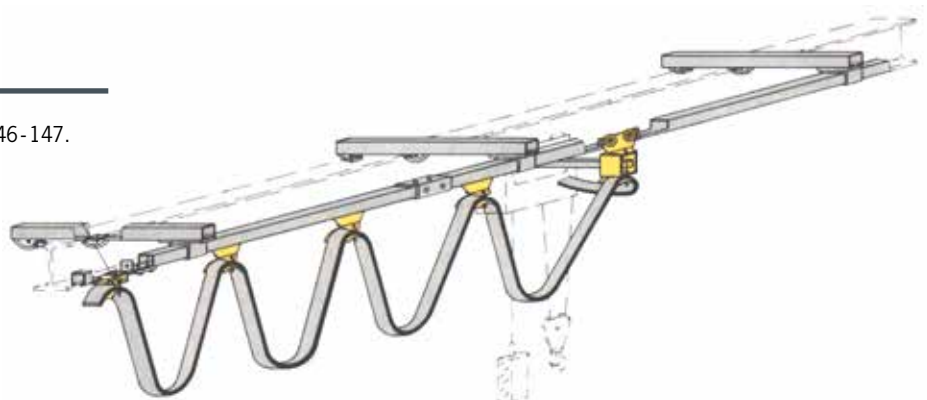

Dimensions CPE¹/CPEF

| Model | CPE ¹ /CPEF 16-8 | CPE ¹ /CPEF 20-8 | CPE ¹ /CPEF 25-5 | CPE ¹ /CPEF 30-5 | CPE ¹ /CPEF 32-4 | CPE ¹ /CPEF 40-4 | CPE ¹ /CPEF 50-2 | CPE ¹ /CPEF 75-1,6 | CPE ¹ /CPEF 100-2 |
|--------------|-----------------------------|-----------------------------|-----------------------------|-----------------------------|-----------------------------|-----------------------------|-----------------------------|-------------------------------|------------------------------|
| A, mm | 516 | 516 | 516 | 516 | 681 | 681 | 681 | 950 | 1068 |
| A1, mm | 286 | 286 | 286 | 286 | 428 | 428 | 428 | 479 | 651 |
| A2 (13m), mm | 430 | 430 | 430 | 430 | 430 | 430 | 430 | - | - |
| A2 (21m), mm | 530 | 530 | 530 | 530 | 530 | 530 | 530 | 530 | 555 |
| B, mm | 35 | 35 | 35 | 35 | 45 | 45 | 45 | 60 | 60 |
| C, mm | 37 | 37 | 37 | 37 | 46 | 46 | 46 | 52 | 52 |
| D, mm | 24 | 24 | 24 | 24 | 30 | 30 | 30 | 40/45 | 40/45 |
| E, mm | 45/50 | 45/50 | 45/50 | 45/50 | 45/50 | 45/50 | 45/50 | - | - |
| F1, mm | 160 | 160 | 160 | 160 | 160 | 160 | 160 | 160 | 160 |
| F2, mm | 184/195 | 184/195 | 184/195 | 184/195 | 184/195 | 184/195 | 184/195 | 184/195 | 184/195 |
| G, mm | 220 | 220 | 220 | 220 | 220 | 220 | 220 | 220 | - |
| G1, mm | 180 | 180 | 180 | 180 | 140 | 140 | 140 | 293/298 | 340/345 |
| G2 (13m), mm | 257 | 257 | 257 | 257 | 218 | 218 | 218 | - | - |
| G2 (21m), mm | 277 | 277 | 277 | 277 | 238 | 238 | 238 | 345 | 408 |
| H1, mm | 110 | 110 | 110 | 110 | 110 | 110 | 110 | 110 | 135 |
| H2, mm | 135 | 135 | 135 | 135 | 135 | 135 | 135 | 307 | 256 |
| K1, mm | 100 | 100 | 100 | 100 | 100 | 100 | 100 | 92 | 92 |
| K2, mm | 51 | 51 | 51 | 51 | 51 | 51 | 51 | 62 | 62 |
| M, mm | 50 | 50 | 50 | 50 | 10 | 10 | 10 | 138 | - |
| N, mm | 105/110 | 105/110 | 105/110 | 105/110 | 145/150 | 145/150 | 145/150 | 136 | 390 |
| Q1, mm | 280 | 280 | 280 | 280 | 280 | 280 | 280 | 280 | 280 |
| Q2, mm | 382/438 | 382/438 | 382/438 | 382/438 | 382/438 | 382/438 | 382/438 | 382/438 | 382/438 |

¹ The model CPE (single speed hoist) is available on request. Please consider the deviating motor dimensions in the above table.

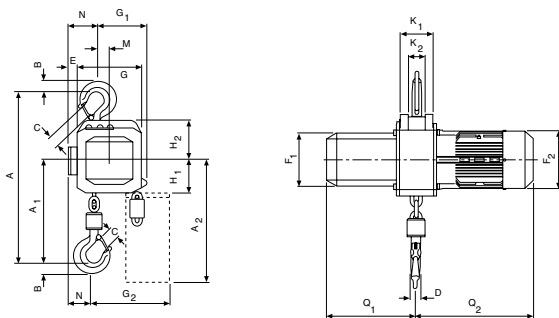

CPE¹/CPEF with suspension hook, 1600 - 3000 kg, single fall

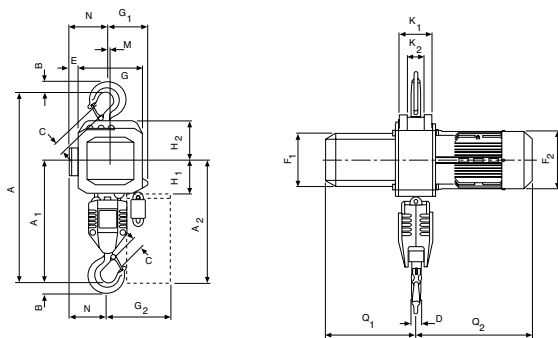

CPE¹/CPEF with suspension hook, 3200 - 5000 kg, double fall

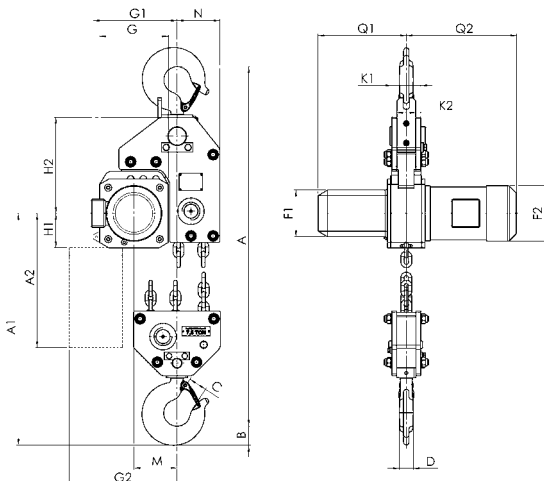

CPE¹/CPEF 75-1,6 with suspension hook, 7500 kg

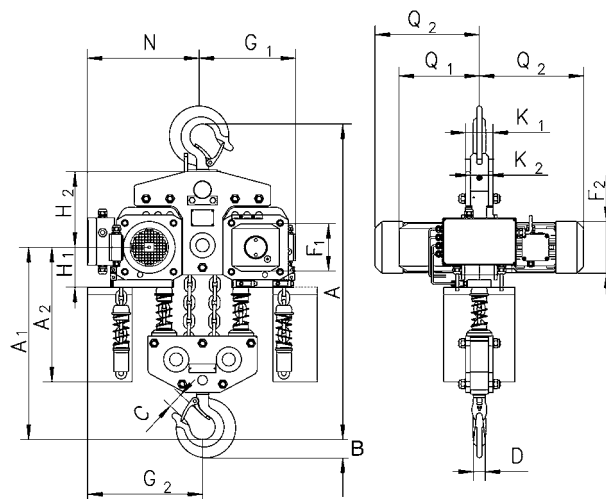

CPE¹/CPEF 100-2 with suspension hook, 10000 kg

Dimensions CPEF

| Model | CPEF 16-8 | CPEF 20-8 | CPEF 25-5 | CPEF 30-5 | CPEF 32-4 | CPEF 40-4 | CPEF 50-2 | CPEF 75-1,6 | CPEF 100-2 |
|---------------|--------------------------------|--------------------------------|--------------------------------|--------------------------------|--------------------------------|--------------------------------|--------------------------------|-------------|------------|
| A3, mm | 121 | 121 | 121 | 121 | 121 | 121 | 121 | - | 110 |
| A4, mm | 465 | 465 | 465 | 465 | 615 | 615 | 615 | 855 | 965 |
| A5, mm | 298 | 298 | 298 | 298 | 298 | 298 | 298 | 477 | 450 |
| A6, mm | 178 | 178 | 178 | 178 | 178 | 178 | 178 | - | 170 |
| b, mm | A = 98 - 180/ B = 180 - 300 | A = 98 - 180/ B = 180 - 300 | A = 98 - 180/ B = 180 - 300 | A = 98 - 180/ B = 180 - 300 | A = 98 - 180/ B = 180 - 300 | A = 98 - 180/ B = 180 - 300 | A = 98 - 180/ B = 180 - 300 | 125 - 310 | 125 - 310 |
| F, mm | 150 | 150 | 150 | 150 | 150 | 150 | 150 | 113 | 113 |
| I, mm | 142.5 | 142.5 | 142.5 | 142.5 | 142.5 | 142.5 | 142.5 | 170 | 170 |
| L1, mm | 209 | 209 | 209 | 209 | 209 | 209 | 209 | 200 | 200 |
| L2, mm | 262.5 | 262.5 | 262.5 | 262.5 | 262.5 | 262.5 | 262.5 | 215 | 215 |
| L3 (VTE), mm | 292 | 292 | 292 | 292 | 292 | 292 | 292 | - | 335 |
| L3 (VTEF), mm | 296 | 296 | 296 | 296 | 296 | 296 | 296 | - | 335 |
| L4, mm | 213 | 213 | 213 | 213 | 253 | 253 | 253 | 215 | 390 |
| L5, mm | 312 | 312 | 312 | 312 | 272 | 272 | 272 | 215 | 215 |
| L6 (VTE), mm | 342 | 342 | 342 | 342 | 342 | 342 | 342 | - | - |
| L6 (VTEF), mm | 346 | 346 | 346 | 346 | 306 | 306 | 306 | - | - |
| O, mm | 125 | 125 | 125 | 125 | 125 | 125 | 125 | 150 | 150 |
| P (VTE), mm | 197 | 197 | 197 | 197 | 197 | 197 | 197 | - | 273 |
| P (VTEF), mm | 205 | 205 | 205 | 205 | 205 | 205 | 205 | - | 280 |
| P1, mm | 229 | 229 | 229 | 229 | 229 | 229 | 229 | - | 110 |
| S, mm | b + 70 | b + 70 | b + 70 | b + 70 | b + 70 | b + 70 | b + 70 | b + 98 | b + 98 |
| T, mm | 94 | 94 | 94 | 94 | 94 | 94 | 94 | - | 94 |
| tmax., mm | 27 | 27 | 27 | 27 | 27 | 27 | 27 | 40 | 40 |

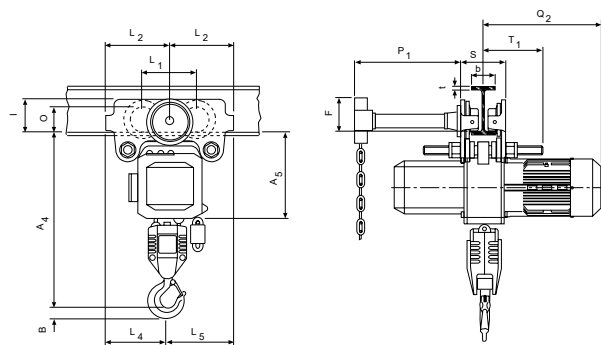

CPE1/CPEF with integrated manual geared trolley

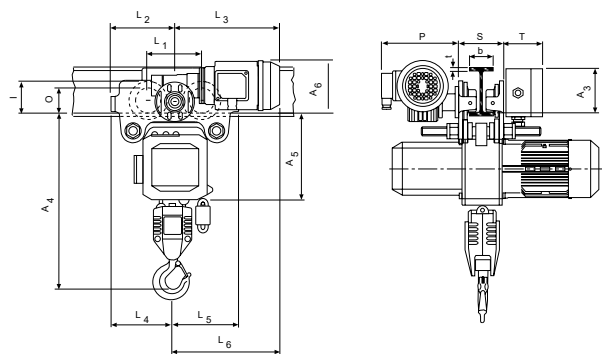

CPE1/CPEF with integrated electric trolley

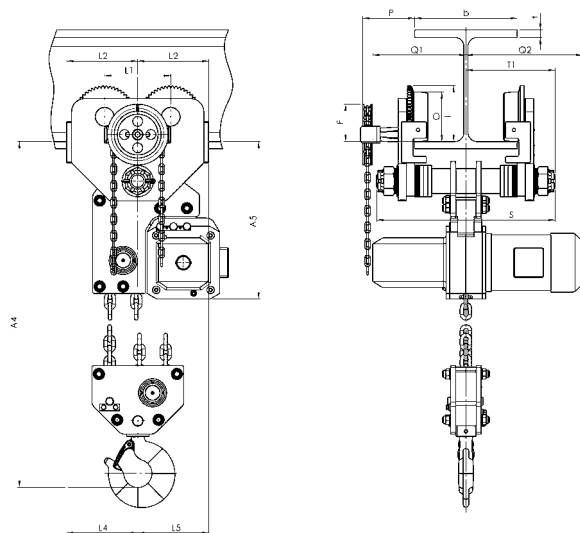

CPE1/CPEF with integrated geared or electric trolley, 7500 kg

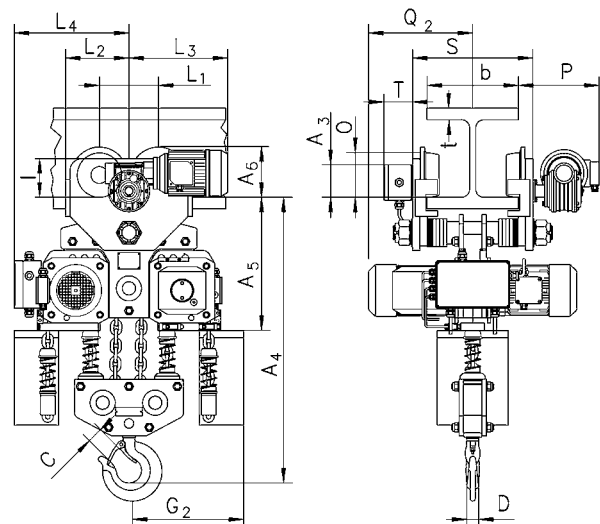

CPE1/CPEF with integrated electric trolley, 10000 kg



Explosion-proof version corresponds to Basic.

CPA Pneumatic chain hoist with suspension hook

Capacity 125 - 980 kg

Pneumatic chain hoists are characterized by high durability in a great number of industrial applications. The robust but light weight housing allows an easy transport.

Features

- Working pressures 5 - 7 bar.
- Rotating piston motor with 100% duty rating and an unlimited number of starts for continuous operation.
- Integrated limit switches for highest and lowest hook position as standard.
- Self-adjusting automatic disc brake.
- Extremely sensitive control with emergency-stop for a precise positioning of the load.
- Air release for brake as standard for model CPA 10-9

Options

- Maintenance unit for main air supply pipe (pressure regulator, manometer, lubricator and support).
- Chain container

Applications

Automobile and aircraft industries, shipyards, on ships and docks. Foundries, on-/offshore, paint factories and paint shops, refineries, oil depots, galvanizing. Printing, textile and food industries, pulp, paper and cement mills. Glass and ceramic industries, wood working industries, chemical industries, heat treatment and power plants etc.

INFO

To ensure faultless operation the compressed air supply must be filtered and oiled!

Also suitable for operation with nitrogen.

Yale hoists and trolleys are not designed for passenger elevation applications and must not be used for this purpose.

Technical data CPA

| Model | Art.-No. | Capacity in kg/ Number of chain falls | Chain dimensions d x p mm | Classification FEM/ISO | Lifting speed with rated load ¹ m/min | Lifting speed without load ¹ m/min | Lowering speed with rated load ¹ m/min | Air consumption with rated load ¹ m ³ /min | Hoist motor kW | Weight at standard lift (3 m) kg |
|----------|-----------|--|---------------------------|------------------------|--|---|---|--|----------------|----------------------------------|
| CPA 1-13 | N08501007 | 125/1 | 4 x 12.2 | 1 Am/M4 | 13.1 | 17.1 | 11.3 | 0.9 | 0.4 | 15.4 |
| CPA 2-10 | N08501008 | 250/1 | 4 x 12.2 | 1 Am/M4 | 9.8 | 17.1 | 13.7 | 0.9 | 0.4 | 15.4 |
| CPA 5-5 | N08501010 | 500/2 | 4 x 12.2 | 1 Am/M4 | 4.6 | 7.9 | 6.7 | 0.9 | 0.4 | 17.2 |
| CPA 10-9 | N08501012 | 980/2 | 6.3 x 19.5 | 1 Bm/M3 | 8.5 | 16.2 | 14.9 | 2.1 | 1.33 | 27.7 |

¹ Values for 6.3 bar flow pressure and 2 m control drop. Speeds will be reduced in case of longer control length.
 CPA 1-13, CPA 2-10 and CPA 5-5 max. hose length 12 m, air supply 3/8" NPT, air consumption 0.9 m³/min.
 CPA 10-9 max. hose length 20 m, air supply 1/2" NPT, air consumption 2.1 m³/min.

Dimensions CPA

| Model | CPA 1-13 | CPA 2-10 | CPA 5-5 | CPA 10-9 |
|--------|----------|----------|---------|----------|
| A, mm | 292 | 292 | 324 | 457 |
| A1, mm | 410 | 410 | 410 | 508 |
| B, mm | 21 | 21 | 14 | 27 |
| C, mm | 20 | 20 | 24 | 28 |
| D, mm | 16 | 16 | 14 | 28 |
| F1, mm | 90 | 90 | 90 | 130 |
| F2, mm | 120 | 120 | 120 | 180 |
| K, mm | 103 | 103 | 103 | 165 |
| L, mm | 57 | 57 | 57 | 83 |
| M, mm | 120 | 120 | 120 | 135 |
| N, mm | 50 | 50 | 50 | 25 |
| Q1, mm | 142 | 142 | 142 | 162 |
| Q2, mm | 183 | 183 | 183 | 181 |

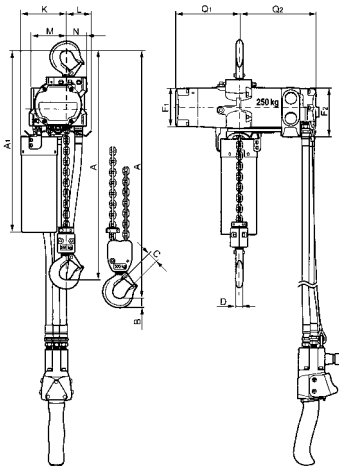

CPA 1-13 / 2-10 / 5-5

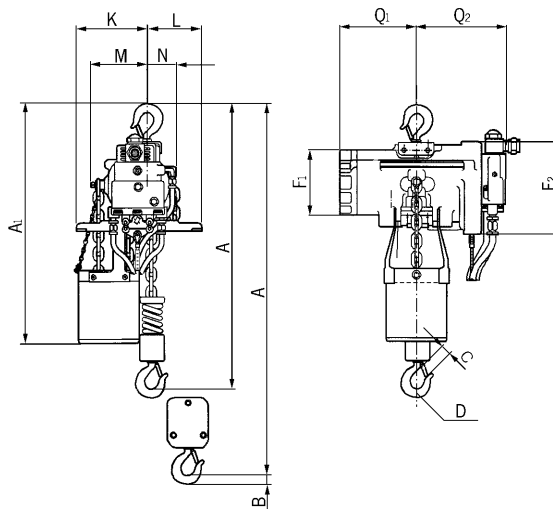

CPA 10-9



Image shows
BASIC design

CPA ATEX Basic Pneumatic chain hoist with suspension hook or with integrated trolley

Capacity 2000 - 10000 kg

With 100% duty rating and an unlimited number of starts the model CPA is suitable for heavy duty applications. It is insusceptible to contamination, humidity and aggressive mediums from the outside.

The hoists are composed of three main components which makes service easy and inexpensive.

Features

- Working pressures 4 - 6 bar.
- Robust rotating piston motor has an adjustable spring pressure brake that holds the load secure even in the event of an air failure.
- The standard, oil bath lubricated planetary gearbox is particularly smooth running and enables a low overall height.
- High starting torque due to switching valves in the motor body.
- Low noise emission due to large dimension silencer.
- Sensitive control by means of 2 resp. 4 button pendant control with emergency-stop.
- The assembly of component parts result in a low overall height (up to 3000 kg only one chain fall).
- The 5-pocket load chain sheave, manufactured from wear resistant case hardening steel, is matched perfectly to the load chain to guarantee smooth and precise chain motion.
- Forged suspension and load hooks are made from non-aging, high tensile steel and fitted with robust safety latches.
- The standard case hardened and zinc-plated link chain is matched perfectly to the load chain to guarantee smooth and precise chain motion.

All requirements of national and international standards and regulations are fulfilled.

Options

- Also available in combination with trolleys, both trolley/hook suspension and with integrated trolley. Also applies to ATEX.
- Rope control
- Limit switch
- Chain container
- Maintenance unit, consisting of pressure regulator, pressure gauge, lubricator and holder
- Mobile maintenance unit
- Stainless steel load chain.

INFO

To ensure faultless operation the compressed air supply must be filtered and oiled!

Also suitable for operation with nitrogen.

Where no maintenance unit can be installed permanently, it is recommended to work with a mobile maintenance unit.

Information for load chain see pages 82-84 please.

Technical data CPA ATEX Basic

| Model | Art.-No. | Capacity in kg/ Number of chain falls | Chain dimensions d x p mm | Classification FEM/ISO | Lifting speed with rated load ¹ m/min | Lifting speed without load ¹ m/min | Lowering speed with rated load ¹ m/min | Hoist motor kW |
|----------------|-----------|--|---------------------------|------------------------|--|---|---|----------------|
| CPA ATEX 20-8 | N08505001 | 2000/1 | 11.3 x 31 | 1 Bm/M3 | 7.4 | 9.9 | 11.0 | 2.6 |
| CPA ATEX 30-6 | N08505002 | 3000/1 | 11.3 x 31 | 1 Bm/M3 | 6.0 | 9.9 | 13.0 | 3.2 |
| CPA ATEX 50-3 | N08505004 | 5000/2 | 11.3 x 31 | 1 Am/M4 | 3.4 | 5.0 | 6.0 | 3.0 |
| CPA ATEX 60-3 | 192069175 | 6000/2 | 11.3 x 31 | 1 Am/M4 | 3.0 | 5.0 | 6.5 | 3.2 |
| CPA ATEX 75-2 | N08505005 | 7500/3 | 11.3 x 31 | 1 Am/M4 | 2.0 | 3.3 | 4.3 | 3.2 |
| CPA ATEX 100-3 | N08505006 | 10000/4 | 11.3 x 31 | 1 Am/M4 | 3.4 | 5.0 | 6.0 | 2 x 3.0 |

¹Values at 6 bar flow pressure and 2 m control hose. Air consumption at nominal load 4.7 m³/min. For CPA 100-3 = 9.4 m³/min, air connection R1". Quick exhaust valves are installed from 11 m upwards, max. hose length 20 m.

| Model | Art.-No. | Weight ² suspension hook kg | Weight ² geared trolley kg | Weight ² pneumatic trolley kg |
|----------------|-----------|--|---------------------------------------|--|
| CPA ATEX 20-8 | N08505001 | 121 | 188 | 199 |
| CPA ATEX 30-6 | N08505002 | 121 | 188 | 199 |
| CPA ATEX 50-3 | N08505004 | 140 | 206 | 218 |
| CPA ATEX 60-3 | 192069175 | 140 | 206 | 218 |
| CPA ATEX 75-2 | N08505005 | on request | on request | on request |
| CPA ATEX 100-3 | N08505006 | on request | on request | on request |

²Weight for standard lift 3 m HOL. Other lifting heights on request.

INFO

Yale hoists and trolleys are not designed for passenger elevation applications and must not be used for this purpose.

INFO

Also available in Medium, High design on request.



We are pleased to send you our new ATEX catalogue in PDF format.

Image shows MEDIUM design incl. rope control



Application with pneumatic trolley



Mobile maintenance unit

Technical data trolleys

| Capacity kg | Size | Beam flange width b mm | Beam flange thickness t max. mm | Curve radius min. m | Pneumatic trolley travel speed m/min | Pneumatic trolley motor kW |
|--------------|------|------------------------|---------------------------------|---------------------|--------------------------------------|----------------------------|
| 2000 - 6000 | A | 98 - 180 | 27 | 2.0 | 18 | 0.55 |
| 2000 - 6000 | B | 180 - 300 | 27 | 1.8 | 18 | 0.55 |
| 7500 - 10000 | B | 125 - 310 | 40 | 1.8 | - | - |

Flow pressure 6 bar, air consumption with rated load 0.75 m³/min, air connection R½".

Dimensions CPA

| Model | CPA 20-8 | CPA 30-6 | CPA 50-3 | CPA 60-3 | CPA 75-2 | CPA 100-3 |
|---------------|----------|----------|----------|----------|----------|-----------|
| A, mm | 516 | 516 | 681 | 681 | 950 | 1068 |
| A1, mm | 286 | 286 | 428 | 428 | 479 | 651 |
| B, mm | 35 | 35 | 45 | 47 | 60 | 60 |
| C, mm | 37 | 37 | 46 | 42 | 52 | 52 |
| D, mm | 24 | 24 | 30 | 30 | 40/45 | 40/45 |
| F1, mm | 160 | 160 | 160 | 160 | 160 | 160 |
| F2, mm | 165 | 165 | 165 | 165 | 165 | 165 |
| G, mm | 220 | 220 | 220 | 220 | 220 | 581 |
| G1, mm | 180 | 180 | 140 | 140 | 268 | 311 |
| G2 (13 m), mm | 258 | 258 | 218 | 218 | - | - |
| G2 (21 m), mm | 278 | 278 | 238 | 238 | 345 | 408 |
| H1, mm | 110 | 110 | 110 | 110 | 110 | 110 |
| H2, mm | 135 | 135 | 135 | 135 | 307 | 256 |
| H3, mm | 115 | 115 | 115 | 115 | 115 | 115 |
| K1, mm | 100 | 100 | 100 | 100 | 92 | 92 |
| K2, mm | 51 | 51 | 51 | 51 | 62 | 62 |
| M, mm | 50 | 50 | 9,6 | 9,6 | 139 | 181 |
| N, mm | 60 | 60 | 100 | 100 | 136 | 291 |
| Q1, mm | 272 | 272 | 272 | 272 | 272 | 272 |
| Q2, mm | 325 | 325 | 325 | 325 | 325 | 325 |

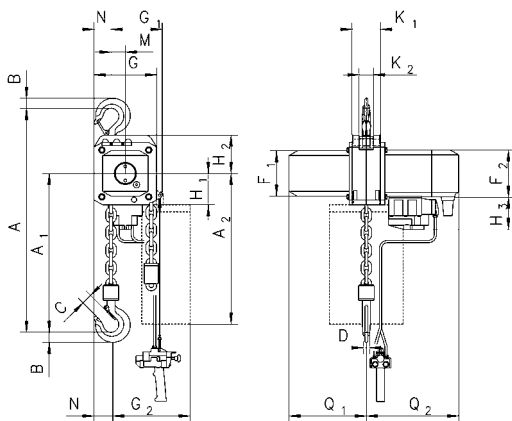

CPA with suspension hook, 2000 - 3000kg, single fall

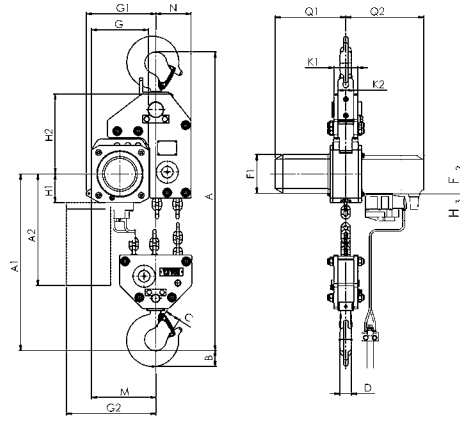

CPA with suspension hook, 7500 kg, three chain falls

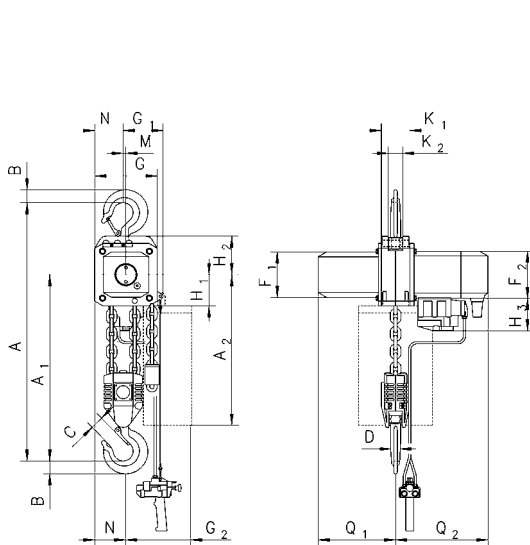

CPA with suspension hook, 4000 - 5000kg, double fall

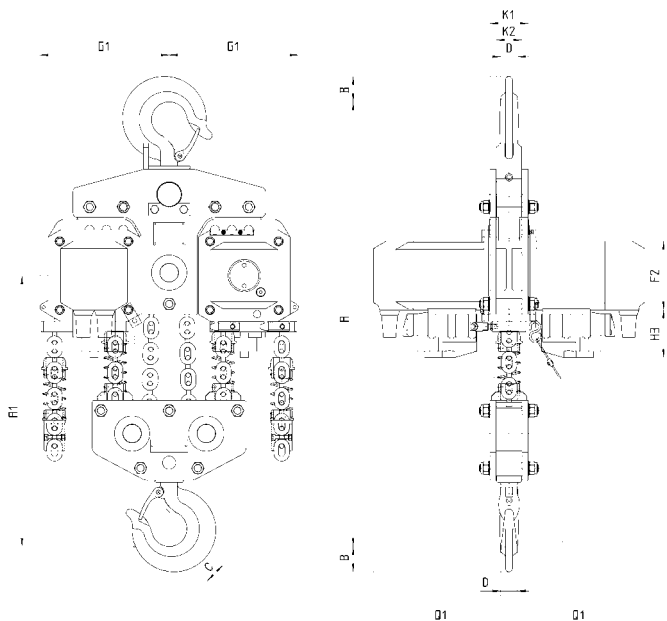

CPA with suspension hook, 10000kg, four chain falls

Dimensions CPA

| Model | CPA 20-8 | CPA 30-6 | CPA 50-3 | CPA 60-3 | CPA 75-2 | CPA 100-3 |
|---------------|--------------------------------|--------------------------------|--------------------------------|--------------------------------|-----------|-----------|
| A2 (13 m), mm | 430 | 430 | 430 | 430 | - | - |
| A2 (21 m), mm | 530 | 530 | 530 | 530 | 530 | 530 |
| A4, mm | 465 | 465 | 615 | 615 | 855 | 965 |
| A5, mm | 298 | 298 | 298 | 298 | 477 | 425 |
| A6, mm | 190 | 190 | 190 | 190 | 182 | 182 |
| b, mm | A = 98 - 180/ B = 180 - 300 | A = 98 - 180/ B = 180 - 300 | A = 98 - 180/ B = 180 - 300 | A = 98 - 180/ B = 180 - 300 | 125 - 310 | 125 - 310 |
| F, mm | 150 | 150 | 150 | 150 | 113 | 113 |
| l, mm | 142.5 | 142.5 | 142.5 | 142.5 | 130 | 130 |
| L1, mm | 209 | 209 | 209 | 209 | 200 | 200 |
| L2, mm | 262.5 | 262.5 | 262.5 | 262.5 | 215 | 215 |
| L3, mm | 265 | 265 | 265 | 265 | 265 | 265 |
| L4, mm | 213 | 213 | 253 | 253 | 291 | 291 |
| L5, mm | 312 | 312 | 272 | 272 | - | - |
| L6, mm | 315 | 315 | 275 | 275 | - | - |
| O, mm | 125 | 125 | 125 | 125 | 150 | 150 |
| P, mm | 208 | 208 | 208 | 208 | 208 | 208 |
| P1, mm | 284 | 284 | 284 | 284 | 284 | 284 |
| S, mm | b + 70 | b + 70 | b + 70 | b + 70 | b + 98 | b + 98 |
| t, mm | 27 | 27 | 27 | 27 | 40 | 40 |
| T1 size A | 182 | 182 | 182 | 182 | - | - |
| T1 size B | 242 | 242 | 242 | 242 | 270 | 270 |

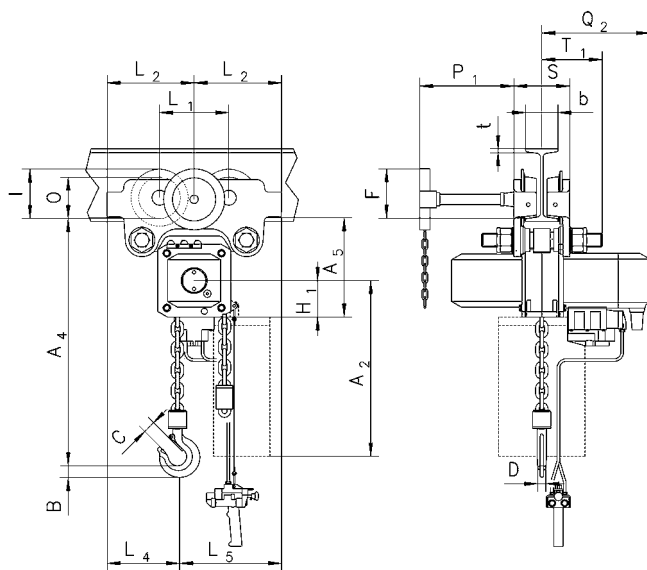

CPA with integrated manual geared trolley

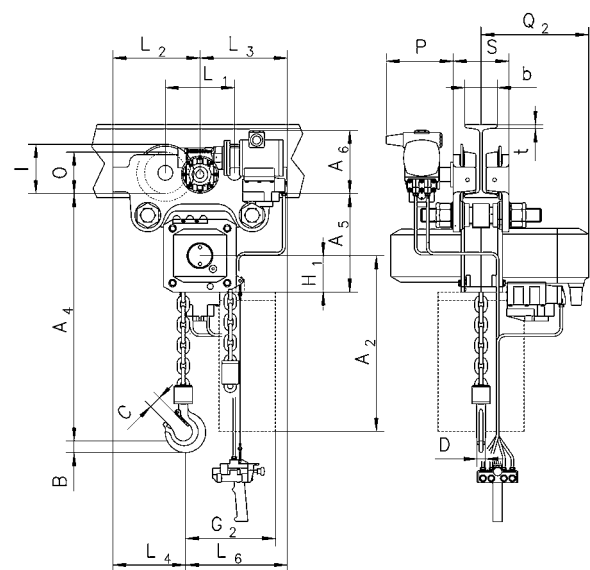

CPA with integrated pneumatic trolley

Yale link chains, zinc-plated

| for | Art.-No. | Capacity kg | Number of chain falls | Chain dimensions d x p mm | Chain stop |
|------------------------------|-----------|----------------|--------------------------|------------------------------------|------------|
| D85 | N01607633 | 750 | 1 | 6 x 18.5 | • |
| | N01607645 | 1500 | 1 | 9 x 27 | • |
| | N01607652 | 3000 | 1 | 11 x 31 | • |
| | N01607652 | 6000 | 2 | 11 x 31 | • |
| | N01607652 | 10000 | 3 | 11 x 31 | • |
| YaleERGO 360 | N02109357 | 750 | 1 | 5.6 x 17.1 | • |
| YaleERGO 360 UT | 192034634 | 1500 | 1 | 7.1 x 21 | • |
| UNOplus-A | 192046315 | 3000 | 1 | 10 x 28 | • |
| | 192046315 | 6000 | 2 | 10 x 28 | • |
| | 192046315 | 9000 | 3 | 10 x 28 | • |
| AL | N02107637 | 750 | 1 | 6.3 x 19.1 | • |
| | N02107637 | 1000 | 1 | 6.3 x 19.1 | • |
| | N02107639 | 1500 | 1 | 7.1 x 21.2 | • |
| | N02107649 | 3000 | 1 | 10 x 30.2 | • |
| PT | N02109357 | 800 | 1 | 5.6 x 17.1 | • |
| | N02107639 | 1600 | 1 | 7.1 x 21.2 | • |
| | N02109358 | 3200 | 1 | 9 x 27.2 | • |
| | N02109358 | 6300 | 2 | 9 x 27.2 | • |
| UNOplus Silverline HZ S | N04307635 | 750 | 1 | 6 x 18 | • |
| | N04307642 | 1500 | 1 | 8 x 24 | • |
| | N04307647 | 3000 | 1 | 10 x 30 | • |
| | N04307647 | 6000 | 2 | 10 x 30 | • |
| Yalehandy | N02100004 | 250 | 1 | 4 x 12 | - |
| | N02100009 | 500 | 1 | 4 x 12 | - |
| YaleMINI 360 | 192084202 | 250 | 1 | 3 x 9 | - |
| | N02100004 | 500 | 1 | 4 x 12 | - |
| Yalelift 360 | N04300008 | 500 | 1 | 5 x 15 | - |
| | N04307635 | 1000 | 1 | 6 x 18 | • |
| | N04307642 | 2000 | 1 | 8 x 24 | • |
| | N04300013 | 3000 | 1 | 10 x 30 | • |
| | N04307647 | 5000 | 2 | 10 x 30 | • |
| | N04300013 | 10000 | 3 | 10 x 30 | • |
| | N04300013 | 20000 | 6 | 10 x 30 | • |
| VSIII Silverline Stira S* | N02100004 | 250 | 1 | 4 x 12 | - |
| | N04300008 | 500 | 1 | 5 x 15 | - |
| | N04307635 | 500*/1000* | 1 | 6 x 18 | • |
| | N04307642 | 1500* | 1 | 8 x 24 | • |
| | N04307635 | 2000 | 2 | 6 x 18 | • |
| | N04307642 | 2000* | 1 | 8 x 24 | • |
| | N04307642 | 3000* | 2 | 8 x 24 | • |
| | N04307647 | 3000 | 1 | 10 x 30 | • |
| | N04307647 | 5000* | 2 | 10 x 30 | • |
| | N04307647 | 10000 | 4 | 10 x 30 | • |
| | N04307647 | 20000 | 8 | 10 x 30 | • |
| | N04307647 | 30000 | 12 | 10 x 30 | • |
| | N04307647 | 50000 | 18 | 10 x 30 | • |
| | CPV/F | N07600001 | 125/250 | 1 | 4 x 12.2 |
| N07600001 | | 500 | 2 | 4 x 12.2 | - |
| N06900001 | | 500 | 1 | 5 x 15.1 | - |
| N06900001 | | 1000 | 2 | 5 x 15.1 | - |
| N06900002 | | 1000 | 1 | 7.1 x 20.5 | • |
| N06900002 | | 2000 | 2 | 7.1 x 20.5 | • |
| N06109488 | | 2500 | 1 | 11 x 31 | • |
| N06109488 | | 5000 | 2 | 11 x 31 | • |
| CPA | | N07600001 | 125-250 | 1 | 4 x 12.2 |
| | N07600001 | 500 | 2 | 4 x 12.2 | - |
| | N08600024 | 980 | 2 | 6.3 x 19.5 | • |
| CPEF | N06109488 | 1600 - 3000 | 1 | 11.3 x 31 | • |
| CPA | N06109488 | 3200 - 6000 | 2 | 11.3 x 31 | • |
| | N06109488 | 7500 | 3 | 11.3 x 31 | • |
| | N06109488 | 10000 | 4 | 11.3 x 31 | • |



Yale link chains, stainless steel

| for | Art.-No. | Capacity kg | Capacity max. stainless steel load chain kg | Number of chain falls | Chain dimensions d x p mm | Chain stop |
|--------------|-----------|----------------|--|--------------------------|------------------------------------|------------|
| D85 | N01607646 | 1500 | 1500 | 1 | 9 x 27 | • |
| AL | N02107638 | 750 | 750 | 1 | 6.3 x 19.1 | • |
| | N02107638 | 1000 | 1000 | 1 | 6.3 x 19.1 | • |
| | N02107640 | 1500 | 1250 | 1 | 7.1 x 21.2 | • |
| | N02107650 | 3000 | 2000 | 1 | 10 x 30.2 | • |
| PT | N02107640 | 1600 | 1250 | 1 | 7.1 x 21.2 | • |
| UNOplus | N04307636 | 750 | 750 | 1 | 6 x 18 | • |
| | N04307643 | 1500 | 1250 | 1 | 8 x 24 | • |
| | N04307648 | 3000 | 2000 | 1 | 10 x 30 | • |
| | N04307648 | 6000 | 4000 | 2 | 10 x 30 | • |
| Yalelift 360 | N07218304 | 500 | 500 | 1 | 5 x 15 | - |
| | N04307636 | 1000 | 900 | 1 | 6 x 18 | • |
| | N04307643 | 2000 | 1500 | 1 | 8 x 24 | • |
| | N04307648 | 3000 | 2500 | 1 | 10 x 30 | • |
| | N04307648 | 5000 | 5000 | 2 | 10 x 30 | • |
| VSIII | N07218304 | 500 | 500 | 1 | 5 x 15 | - |
| | N04307636 | 1000 | 900 | 1 | 6 x 18 | • |
| | N04307643 | 1500 | 1500 | 1 | 8 x 24 | • |
| | N04307636 | 2000 | 1800 | 2 | 6 x 18 | • |
| | N04307643 | 2000 | 1500 | 1 | 8 x 24 | • |
| | N04307643 | 3000 | 3000 | 2 | 8 x 24 | • |
| | N04307648 | 3000 | 2500 | 1 | 10 x 30 | • |
| | N04307648 | 5000 | 5000 | 2 | 10 x 30 | • |
| | N04307648 | 10000 | 10000 | 4 | 10 x 30 | • |
| | N04307648 | 20000 | 20000 | 8 | 10 x 30 | • |
| | N04307648 | 30000 | 30000 | 12 | 10 x 30 | • |
| | N04307648 | 50000 | 45000 | 18 | 10 x 30 | • |
| CPV/F | N07600002 | 125/250 | 125/250 | 1 | 4 x 12.2 | - |
| | N07600002 | 500 | 500 | 2 | 4 x 12.2 | - |
| | N06900012 | 500 | 500 | 1 | 5 x 15.1 | - |
| | N06900012 | 1000 | 1000 | 2 | 5 x 15.1 | - |
| | N06900013 | 1000 | 800 | 1 | 7.1 x 20.5 | • |
| | N06900013 | 2000 | 1600 | 2 | 7.1 x 20.5 | • |
| CPA | N07600002 | 125/250 | 125/250 | 1 | 4 x 12.2 | - |
| | N07600002 | 500 | 500 | 2 | 4 x 12.2 | - |
| | N08600025 | 980 | 980 | 2 | 6.3 x 19.5 | • |
| CPEF CPA | N06100001 | 1600/2000 | 1600/2000 | 1 | 11.3 x 31 | • |
| | N06100001 | 2500/3000 | 2000 | 1 | 11.3 x 31 | • |
| | N06100001 | 3200/4000 | 3200/4000 | 2 | 11.3 x 31 | • |
| | N06100001 | 5000/6000 | 4000 | 2 | 11.3 x 31 | • |
| | N06100001 | 7500 | 6000 | 3 | 11.3 x 31 | • |
| | N06100001 | 10000 | 8000 | 4 | 11.3 x 31 | • |

Yale roller chains

| for | Art.-No. | Capacity in kg/ Number of chain falls | Chain dimensions p x b ₁ inch | Chain stop |
|------|-----------|--|---|------------|
| C 85 | N01244800 | 750/1 | 5/8" x 3/8" | • |
| | N01245700 | 1500/1 | 1" x 1/2" | • |
| | N01245701 | 3000/1 | 1 1/4" x 5/8" | • |



Yale hand chains, zinc-plated or stainless steel

| for | Chain dimensions d x p in mm | Art.-No. zinc-plated | Art.-No. stainless steel |
|----------------------------------|---------------------------------|-------------------------|-----------------------------|
| HTG, VSplus, VSIII, Yalelift 360 | 5 x 26 | N04307654 | N04307655 |
| - Connection link for hand chain | 5 x 26 | N00404733 | N00400668 |
| VSIII 250, YaleMINI 360 | 3x15 | N04300019 | - |
| - Connection link for hand chain | 3x15 | N00440172 | - |



stainless steel



zinc-plated

INFO

The Yale chain stop - Proven in use for more than 10 years!

The YKST was developed especially for the requirements in overhead line construction and was then dynamically tested by an independent body!



YKST Yale chain stop for link chains

| Model | Art.-No. | Capacity kg | Suitable for chain diameter mm | Dimension L x W x D mm |
|-----------|-----------|----------------|--------------------------------------|------------------------------|
| YKST 1600 | N00100115 | 1600 | 5.6 - 8 | 75 x 56 x 15 |
| YKST 3200 | N00100110 | 3400 | 9 - 11 | 105 x 82 x 24 |

The use for different chain dimensions is not permitted.

YKST Yale chain stop for roller chains

| Model | Art.-No. | Capacity kg | Suitable for chain dimensions |
|-----------|-----------|----------------|----------------------------------|
| YKST 750 | N00100146 | 750 | 5/8" x 3/8" |
| YKST 1500 | N00100143 | 1500 | 1" x 1/2" |
| YKST 3400 | N00100156 | 3400 | 1 1/4" x 5/8" |

The use for different chain dimensions is not permitted.

YKST Yale chain stop for round link or roller chains

The Yale chain stop is designed to be used as an additional fall arrester for round link and roller chains. Especially where oscillations and vibrations could cause the load chain to slip, chain stops can reliably increase safety! For this purpose, the chain stopper YKST should be positioned as close as possible to the housing of the unit and should be repositioned after the hoist has been operated so that the dynamics are as low as possible. After pressing the slider, the chain stopper can be moved on the load chain of the hoist and locks itself by means of spring force after positioning on the chain. The YKST can only be actively unlocked by the release mechanism of the actively unlocked by the release mechanism of the slider. **This prevents accidental loosening during operations.!**



Chain stop attached to roller chain



Chain stop attached to link chain

INFO

The nominal load marked on the chain stopper is the max. load, that each single chain fall can lift, but not the nominal load of the hoist for example model D 85, 10t, three chain falls, satisfy 3334 kg per chain fall.

INCREASED PRODUCTIVITY AUTOMATICALLY ACTING SAFETY GEAR

With both options, the YaleERGO 360® UT does not need to be readjusted after the individual steps but is only required in neutral mode. Further information please see pages 20-23!

INFO

The chain claw - the simple alternative. Fast and practical.



KKL Yale chain claw for round link chains

| Model | Art.-No. | Capacity kg | Suitable for chain-Ø mm |
|----------|-----------|----------------|-------------------------------|
| KKL 2000 | 192080829 | 2000 | 7 - 8 |
| KKL 3150 | 192080830 | 3150 | 10 |

The use for different chain dimensions is not permitted.

KKL Yale chain claw for round link chains

The KKL also offers the operator additional safety with dynamic loads! Due to the lack of additional mechanical locking, the chain claw can be moved faster than the chain stop. It replaces the chain end piece and thus saves additional weight! Here too, the attachment point should be as close to the housing as possible, for optimal safety.

SW-W Wall-mounted winch

Capacity 80 - 750 kg

Wall-mounted rope winches of the SW-W model range are intended for fixed stationary mounting inside a building. The steel wire rope is guided to the required suspension point of the load by means of deflection sheaves.

Features

- Robust aluminium housing for models SW-W 80 and SW-W 125, proven steel plate design for models SW-W 300 - 750.
- Spur gear drive for optimal efficiency and comfortable handling. Direct drive for loads up to 125 kg.
- The low-noise safety spring brake safely holds the load in every position.
- Removable hand crank for models SW-W 80 and SW-W 125, foldable crank for models SW-W 300 - 750.
- Easy and quick mounting onto walls.



Technical data SW-W

| Model | Art.-No. | Capacity 1 st layer kg | Capacity top layer kg | Drum diameter mm | Rope diameter ¹ mm | Useable rope length 1 st layer m | Useable rope length top layer m | Lift per crank rotation mm | Required crank effort daN | Weight without rope kg |
|----------|------------|--------------------------------------|--------------------------|---------------------|----------------------------------|--|------------------------------------|-------------------------------|------------------------------|---------------------------|
| SW-W 80 | N040271017 | 80 | 45 | 51 | 3 | 2.4 | 30 | 170 | 12 | 3 |
| SW-W 125 | N040271008 | 125 | 65 | 40 | 4 | 2 | 12 | 138 | 13 | 3 |
| SW-W 300 | 30271001 | 300 | 220 | 108 | 5 | 2.1 | 15 | 68 | 15 | 10 |
| SW-W 500 | 30271136 | 500 | 350 | 108 | 6 | 2.4 | 15 | 35 | 13 | 11 |
| SW-W 750 | 30271019 | 750 | 550 | 108 | 7 | 2 | 10 | 35 | 20 | 11 |

¹recommended rope: EN 12385 FE-znk 1770 sZ-spa

Dimensions SW-W

| Model | SW-W 80 | SW-W 125 | SW-W 300 | SW-W 500 | SW-W 750 |
|---------|---------|----------|----------|----------|----------|
| A, mm | 110 | 110 | 250 | 250 | 250 |
| B, mm | 110 | 110 | 250 | 250 | 250 |
| C, mm | 130 | 130 | 290 | 290 | 290 |
| D, mm | 130 | 130 | 290 | 290 | 290 |
| Ø E, mm | 9 | 9 | 14.5 | 14.5 | 14.5 |
| F, mm | 15 | 15 | 2 | 2 | 2 |
| H, mm | 121 | 121 | 85 | 85 | 85 |
| I, mm | 55 | 55 | 138 | 138 | 138 |
| J, mm | - | - | 117 | 117 | 117 |
| K, mm | 250 | 250 | 250 | 250 | 250 |
| L, mm | 130 | 130 | 130 | 130 | 130 |
| M, mm | 68 | 68 | 39 | 39 | 39 |
| O, mm | 60 | 60 | 50 | 50 | 50 |
| P, mm | 275 | 275 | 192 | 192 | 192 |

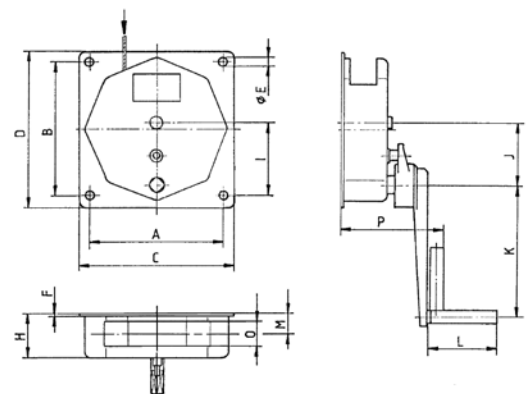



SW-W ALPHA Wall-mounted winch

Capacity 300 - 1000 kg

A versatile wall-mounted winch for an easy lifting of loads.

Features

- Light weight robust stamped steel housing and compact design.
- Spur gear drive for optimal efficiency and comfortable handling.
- Rope lead-offs to all directions.
- All parts are zinc-plated for increased corrosion protection, drum with additional special coating.
- Integrated crank with load pressure brake for safe holding of the load.
- Easy and quick mounting onto walls.

INFO

For a better guiding of the rope to the suspension point we recommend the use of sheaves or sheave blocks, please see page 95.

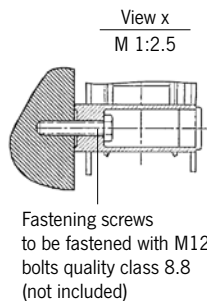

Technical data SW-W ALPHA

| Model | Art.-No. | Capacity 1 st layer kg | Capacity top layer kg | Drum length mm | Rope diameter ¹ mm | Useable rope length 1 st layer m | Useable rope length top layer m | Lift per crank rotation mm | Required crank effort daN | Weight without rope kg |
|-----------------|----------|--------------------------------------|--------------------------|-------------------|----------------------------------|--|------------------------------------|-------------------------------|------------------------------|---------------------------|
| SW-W ALPHA 300 | 30272006 | 300 | 130 | 50 | 5 | 1.3 | 28 | 57 | 13 | 10 |
| SW-W ALPHA 500 | 30272005 | 500 | 230 | 50 | 6 | 1 | 20 | 55 | 17 | 10 |
| SW-W ALPHA 750 | 30272002 | 750 | 270 | 50 | 7 | 1 | 26 | 45 | 17 | 16 |
| SW-W ALPHA 1000 | 30272001 | 1000 | 360 | 50 | 7 | 1 | 26 | 45 | 18 | 16 |

¹recommended rope: EN 12385 FE-znk 1770 sZ-spa

Dimensions SW-W ALPHA

| Model | SW-W ALPHA 300 | SW-W ALPHA 500 | SW-W ALPHA 750 | SW-W ALPHA 1000 |
|---------|----------------|----------------|----------------|-----------------|
| A, mm | 234 | 234 | 306 | 306 |
| B, mm | 262 | 262 | 337 | 337 |
| C, mm | 274 | 274 | 357 | 357 |
| D, mm | 203 | 203 | 265 | 265 |
| E, mm | 107 | 107 | 107 | 107 |
| F, mm | 194 | 194 | 194 | 194 |
| G, mm | 183 | 183 | 255 | 255 |
| Ø H, mm | 63 | 63 | 63.5 | 63.5 |
| I, mm | 200 | 250 | 250 | 320 |
| J, mm | 58.6 | 58.6 | 92.5 | 92.5 |
| K, mm | 109.5 | 109.5 | 107 | 107 |

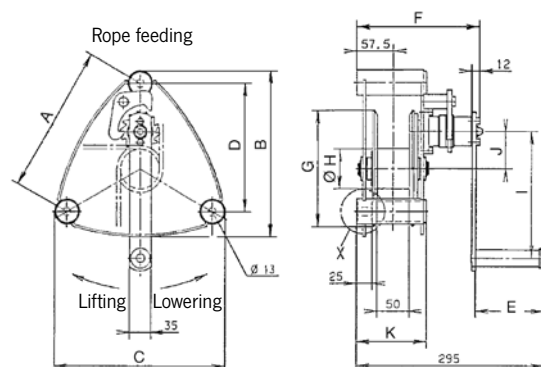

SW-W-SGO Wall-mounted winch with worm gear drive

Capacity 250 - 5000 kg

Wall-mounted winch with worm gear drive and load pressure brake for efficient lifting of heavy loads.

Features

- Housing and rope drums made out of robust steel plate.
- Worm gear drive with additional load pressure brake for safe holding of the load.
- Roller bearings ensure smooth running of the rope and increased lifetime of the winch.
- Second speed for fast lifting of smaller loads, resulting in lowest possible handle effort and rapid winding of the rope (for capacities of 2000 kg and above).
- Wide rope drum for a large rope capacity with two rope attachment points.
- Easy and quick mounting.



SW-W-SGO,
capacity 1500 kg

Technical data SW-W-SGO

| Model | Art.-No. | Capacity 1 st layer kg | Capacity top layer kg | Rope diameter ¹ mm | Useable rope length 1 st layer m | Useable rope length top layer m | Lift per crank rotation mm | Required crank effort daN | Weight without rope kg |
|----------|----------|--------------------------------------|--------------------------|----------------------------------|--|------------------------------------|-------------------------------|------------------------------|---------------------------|
| SGO 250 | 40251003 | 250 | 92 | 4 | 3.6 | 104 | 17 | 6 | 10 |
| SGO 500 | 40252026 | 500 | 224 | 6 | 4.3 | 78 | 20 | 10 | 13 |
| SGO 1000 | 40253006 | 1000 | 527 | 8 | 5.5 | 63 | 13 | 13 | 22 |
| SGO 1500 | 40253000 | 1500 | 846 | 10 | 4.2 | 41 | 9 | 14 | 24 |
| SGO 2000 | 30254002 | 2000 | 1038 | 12 | 5.4 | 75 | 5/12 ² | 11/24 ² | 60 |
| SGO 3000 | 30255009 | 3000 | 1667 | 14 | 5.7 | 68 | 5/11 ² | 14/31 ² | 78 |
| SGO 5000 | 30256013 | 5000 | 3276 | 18 | 5.2 | 43 | 3/13 ² | 14/73 ² | 117 |

¹recommended rope: EN 12385 FE-znk 1770 sZ-spa

²1st/2nd speed

Dimensions SW-W-SGO

| Model | SGO 250 | SGO 500 | SGO 1000 | SGO 1500 | SGO 2000 | SGO 3000 | SGO 5000 |
|---------|---------|---------|----------|----------|----------|----------|----------|
| A, mm | 238 | 269 | 302 | 302 | 410 | 436 | 436 |
| B, mm | 145 | 160 | 195 | 250 | 310 | 380 | 467 |
| C, mm | 100 | 115 | 141 | 178 | 196 | 251 | 316 |
| D, mm | 192 | 223 | 254 | 254 | 360 | 386 | 386 |
| G, mm | 107 | 108 | 109 | 109 | 137 | 137 | 137 |
| H, mm | 105 | 135 | 162 | 162 | 177 | 203 | 200 |
| Ø J, mm | 48 | 70 | 102 | 102 | 133 | 162 | 219 |
| Ø K, mm | 14 | 14 | 17 | 17 | 25 | 25 | 25 |
| Ø L, mm | 160 | 190 | 240 | 240 | 312 | 375 | 437 |
| M, mm | 191 | 221 | 266 | 278 | 372 | 480 | 515 |
| N, mm | 15 | 15 | 15 | 15 | 45 | 47 | 60 |
| O, mm | 365 | 393 | 440 | 451 | 705 | 813 | 847 |
| P, mm | 280 | 325 | 350 | 350 | 380 | 380 | 380 |
| R, mm | 171 | 193 | 263 | 306 | 434 | 536 | 618 |
| S, mm | 132 | 132 | 132 | 132 | 220 | 220 | 220 |

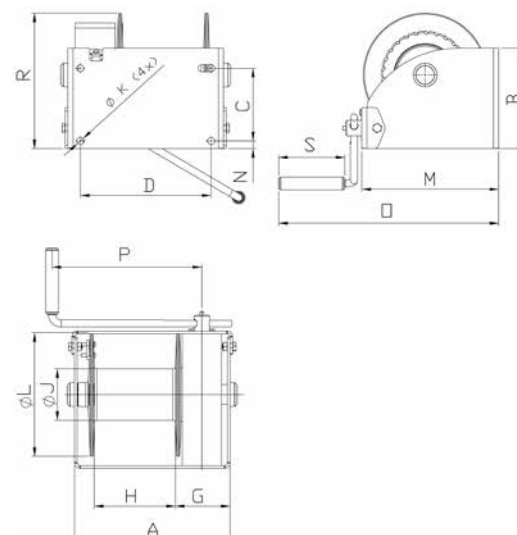



MWS Manual winch with spur gear drive

Capacity 150 - 1500 kg

For the operation where no electricity is available or in a dirty environment.

Recommended rope diameter according to EN 12385 FE-znk 1770 sZ-spa.

The rope is not included in the delivery.

Features

- Enclosed gear drive for protection of internal parts, even under tough working conditions.
- Spur gears on roller bearings, rope drum on plain bearings.
- Compact design.
- Easy and quick mounting onto walls, poles etc.
- They have a self-locking, anti-kickback and adjustable crank handle for fast lifting of smaller loads, resulting in lowest possible handle effort and rapid winding of the rope.
- Automatic load pressure brake for safe holding and extremely sensitive lowering of the load. Unintentional brake release is prevented even with swinging loads.
- They are suitable for operation in ambient temperatures of - 10 °C up to + 50 °C.

Option

- Corrosion resistant version.

INFO

For a better guiding of the rope to the suspension point we recommend the use of sheaves or sheave blocks, please see page 95.

Pfaff winches are not designed for passenger elevation applications and must not be used for this purpose.

Technical data MWS

| Model | Art.-No. | Capacity 1 st layer | Capacity top layer | Crank effort 1 st layer | Lift per crank rotation 1 st layer | Lift per crank rotation top layer | Weight without rope | Rope diameter ¹ | Useable rope length 1 st layer | Useable rope length top layer max. | Number of layers max. |
|----------|-----------|--------------------------------|--------------------|------------------------------------|---|-----------------------------------|---------------------|----------------------------|---|------------------------------------|-----------------------|
| | | kg | kg | daN | mm | mm | kg | mm | m | m | |
| MWS 150 | N02800013 | 150 | 67 | 11 | 122 | 210 | 4 | 4 | 0.8 | 13 | 8 |
| MWS 300 | N02800014 | 300 | 172 | 6 | 32 | 44 | 10 | 4 | 1.8 | 35 | 7 |
| MWS 600 | N02800015 | 600 | 366 | 10 | 28 | 41 | 11 | 6 | 1.2 | 12 | 6 |
| MWS 1000 | N02800018 | 1000 | 614 | 11 | 20 | 27 | 27 | 8 | 3.0 | 33 | 5 |
| MWS 1500 | N02800019 | 1500 | 927 | 12 | 14 | 19 | 27.5 | 10 | 2.7 | 21 | 5 |

¹recommended rope: EN 12385 FE-znk 1770 sZ-spa

Dimensions MWS

| Model | MWS 150 | MWS 300 | MWS 600 | MWS 1000 | MWS 1500 |
|---------|---------|---------|---------|----------|----------|
| A, mm | 65 | 200 | 200 | 219 | 219 |
| B, mm | 168 | 300 | 300 | 250 | 250 |
| C, mm | 128 | 268 | 268 | 212 | 212 |
| D, mm | 40 | 168 | 168 | 150 | 150 |
| E, mm | 303 | 318 | 318 | 484 | 484 |
| F, mm | - | - | - | 250 | 250 |
| G, mm | 26 | - | - | 30 | 30 |
| H, mm | 41 | 55 | 55 | 113 | 113 |
| I, mm | - | - | - | 170 | 170 |
| Ø J, mm | 35 | 70 | 60 | 102 | 102 |
| K, mm | 9 | 12 | 12 | 17 | 17 |
| Ø L, mm | 102 | 145 | 145 | 212 | 212 |
| M, mm | 168 | 182 | 182 | 130 | 130 |
| N, mm | 89 | 199 | 199 | 338 | 338 |
| O, mm | 92 | 96 | 96 | 44 | 44 |
| P, mm | - | - | - | 104 | 104 |
| Q, mm | - | - | - | 190 | 190 |
| S, mm | 129 | 129 | 129 | 129 | 129 |

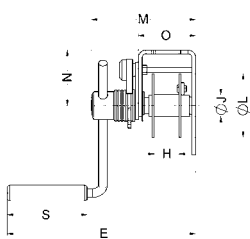

MWS, Capacity 150 kg

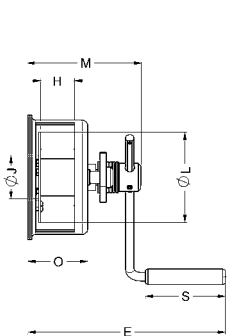
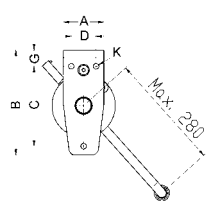

MWS, Capacity 300 - 600 kg

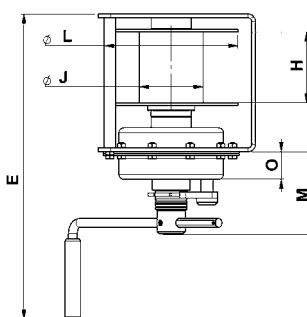
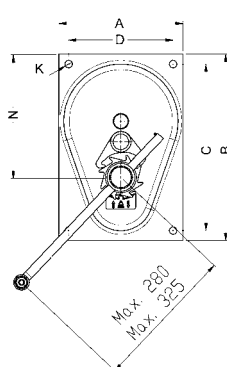

MWS, Capacity 1000 - 1500 kg

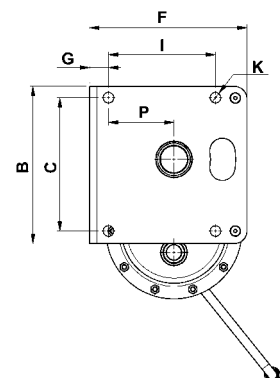
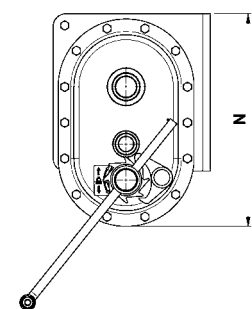



LB, zinc-plated version,
capacity 1200 kg



LB, zinc-plated version,
capacity 350 kg

LB Console-mounted winch

Capacity 150 - 1200 kg

Originally developed as offroad winch the console-mounted winch model LB is used today for a variety of lifting and pulling applications.

Features

- Light weight robust stamped steel housing.
- Spur gear drive for optimal efficiency and comfortable handling.
- Automatic load pressure brake for safe holding of the load in any position. An unintentional brake release is prevented.
- All parts are zinc-plated for increased corrosion protection, drum with additional special coating.
- Easy and quick mounting to consoles, even under lifting conditions.

Options

- Stainless steel version (mat. 1.4301) for increased corrosion protection.

INFO

For a better guiding of the rope to the suspension point we recommend the use of sheaves or sheave blocks, please see page 95.

Pfaff winches are not designed for passenger elevation applications and must not be used for this purpose.



LB-VA, stainless steel version,
capacity 900 kg

Technical data LB

| Model | Art.-No. | Capacity 1 st layer kg | Capacity top layer kg | Rope diameter mm | Useable rope length 1 st layer m | Useable rope length top layer m | Lift per crank rotation mm | Required crank effort daN | Weight without rope kg |
|------------|----------|--------------------------------------|--------------------------|---------------------|--|------------------------------------|-------------------------------|------------------------------|---------------------------|
| LB 150 VZ | 30239016 | 150 | 75 | 4 ¹ | 0.8 | 11 | 125 | 17 | 4.2 |
| LB 350 VZ | 30239015 | 350 | 170 | 4 ¹ | 1.8 | 20 | 125 | 25 | 4.8 |
| LB 650 VZ | 41239004 | 650 | 290 | 6 ¹ | 1 | 20 | 55 | 22 | 7.3 |
| LB 900 VZ | 41239006 | 900 | 400 | 7 ¹ | 0.8 | 14 | 58 | 24 | 10 |
| LB 1200 VZ | 42239008 | 1200 | 430 | 7 ² | 1 | 26 | 45 | 24 | 12.1 |
| LB 250 VA | 32239017 | 250 | 125 | 4 ¹ | 1.8 | 19.5 | 125 | 20 | 4.8 |
| LB 650 VA | 42239012 | 650 | 290 | 6 ¹ | 1 | 20 | 55 | 22 | 7.6 |
| LB 900 VA | 32239013 | 900 | 320 | 7 ¹ | 1 | 26 | 45 | 24 | 12.1 |

¹recommended rope: EN 12385 FE-znk 1770 sZ-spa

²recommended rope: EN 12385 SE-znk 2160 sZ-spa

Dimensions LB

| Model | LB 150 VZ | LB 350 VZ | LB 650 VZ | LB 900 VZ | LB 1200 VZ | LB 250 VA | LB 650 VA | LB 900 VA |
|---------|-----------|-----------|-----------|-----------|------------|-----------|-----------|-----------|
| A, mm | – | – | 232 | 232 | 273 | – | 232 | 273 |
| B, mm | 155 | 155 | 192 | 192 | 266 | 155 | 192 | 266 |
| C, mm | 175 | 175 | 210 | 210 | 240 | 175 | 210 | 240 |
| Ø D, mm | 36 | 36 | 63.5 | 63.5 | 63.5 | 36 | 63.5 | 63.5 |
| Ø E, mm | 100 | 100 | 183 | 183 | 255 | 100 | 183 | 255 |
| F, mm | – | – | 100 | 100 | 78 | – | 100 | 78 |
| G, mm | 75 | 75 | 58 | 58 | 75 | 75 | 58 | 75 |
| H, mm | – | – | 100 | 100 | 138 | – | 100 | 138 |
| K, mm | 159 | 189 | 192 | 192 | 192 | 191.5 | 190 | 190 |
| L, mm | – | – | 25 | 25 | 35 | – | 25 | 35 |
| M, mm | 45 | 75 | 38 | 38 | 30 | 75 | 38 | 30 |
| N, mm | – | – | – | – | 53 | – | – | 53 |
| O, mm | 200 | 320 | 250 | 320 | 320 | 320 | 250 | 250 |
| P, mm | 260 | 290 | 293 | 293 | 293 | 292.5 | 291 | 291 |
| Q, mm | 81 | 111 | 95 | 95 | 95 | 111 | 95 | 95 |
| R, mm | 50 | 80 | 50 | 50 | 50 | 80 | 50 | 50 |
| S, mm | 48 | 63 | 55 | 55 | 55 | 65.5 | 55 | 55 |

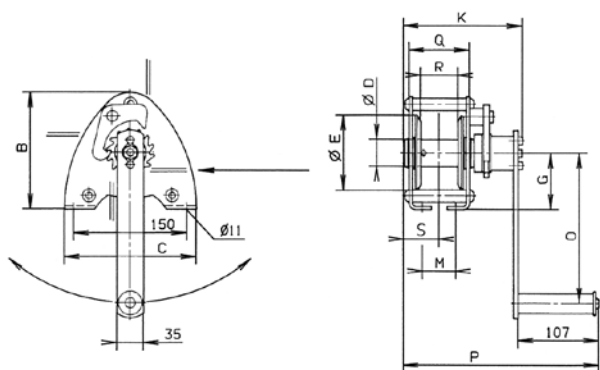

LB, capacities 150 - 350 kg

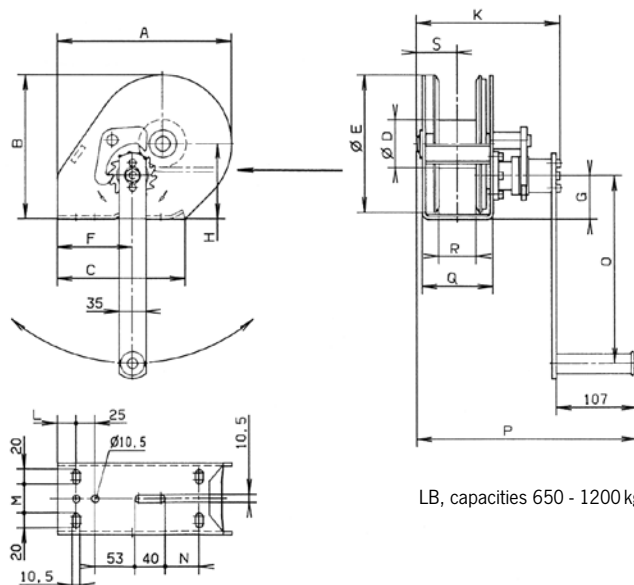

LB, capacities 650 - 1200 kg



SW-K GAMMA
Capacity 800 kg



SW-K GAMMA
Capacity 500 kg

SW-K GAMMA Console-mounted aluminium rope winch

Capacity 200 - 800 kg

Due to its rugged design, the aluminium rope winch is suitable for operation outdoors.

Features

- Compact aluminium housing and enclosed sprocket wheel drive. From a capacity of 500 kg with speed increasing ratio for small loads and quicker winding and unwinding of the unloaded rope.
- Spur gear drive for optimal efficiency and comfortable handling.
- Enclosed gear for the protection of parts inside, also for arduous applications.
- Low-friction shaft sliding bearings for improved rope lead-off and a longer service life of the winch.
- Wide rope drum for a large rope capacity with two rope attachment points.
- Easy and quick mounting.
- With integrated safety spring brake system and removable crank. The winches can be operated from either side.

Technical data SW-K GAMMA

| Model | Art.-No. | Capacity 1 st layer kg | Capacity top layer kg | Rope diameter ¹ mm | Useable rope length 1 st layer m | Useable rope length top layer m | Lift per crank rotation mm | Required crank effort daN | Weight without rope kg |
|-----------|------------|--------------------------------------|--------------------------|----------------------------------|--|------------------------------------|-------------------------------|------------------------------|---------------------------|
| GAMMA 200 | N040270004 | 200 | 110 | 4 | 3.6 | 40 | 195 | 19 | 6 |
| GAMMA 500 | N040270001 | 500 | 200 | 6 | 4.2 | 50 | 60/400 ² | 12 | 14 |
| GAMMA 800 | N040270006 | 800 | 350 | 7 | 5.3 | 78 | 36/280 ² | 18 | 16 |

¹recommended rope: EN 12385 FE-znk 1770 sZ-spa

²load/speed increasing ratio

| Model | Art.-No. | consists of |
|-----------|------------|---------------------|
| GAMMA 200 | N040270004 | 30270004 + 39000153 |
| GAMMA 500 | N040270001 | 30270001 + 40033612 |
| GAMMA 800 | N040270006 | 30270006 + 39000153 |

Dimensions SW-K GAMMA

| Model | GAMMA 200 | GAMMA 500 | GAMMA 800 |
|---------|-----------|-----------|-----------|
| A, mm | 120 | 120 | 200 |
| B, mm | 160 | 220 | 326 |
| C, mm | 192 | 330 | 336 |
| D, mm | 152 | 100 | 180 |
| E, mm | 165 | 267 | 327 |
| F, mm | 135 | 125 | 250 |
| Ø G, mm | 9.5 | 11 | 14 |
| Ø H, mm | 50 | 60 | 70 |
| L, mm | 320 | 250 | 320 |
| M, mm | 207 | 165 | 207 |

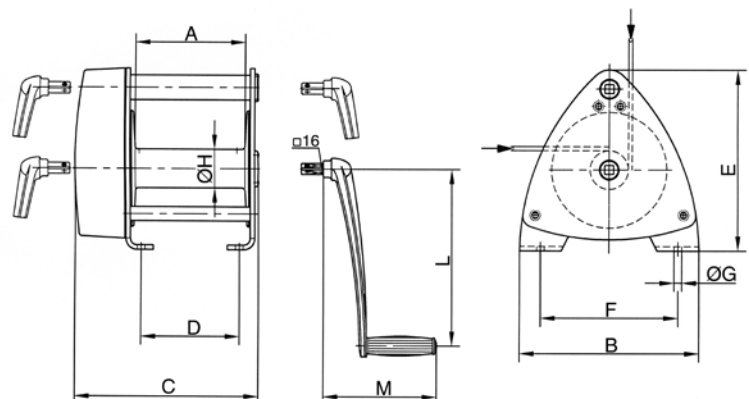

SW-KAL Compact aluminium rope winch with free-wheeling device

Capacity 750 - 1120 kg

Console-mounted rope winches are used for super-structures on vehicles and trailers and when lifting and lowering loads.

Features

- Self-locking worm gear, free-wheeling device for ease of operation.
- Enclosed gear for the protection of internal parts, also for arduous applications.
- Low-friction shaft bearings for a longer service life of the winch.
- Easy and quick mounting.



INFO

Pfaff winches are not designed for passenger elevation applications and must not be used for this purpose.

Technical data SW-KAL

| Model | Art.-No. | Capacity 1 st layer kg | Capacity top layer kg | Drum diameter mm | Rope diameter ¹ mm | Useable rope length 1 st layer m | Useable rope length max. m | Lift per crank rotation mm | Lift per crank rotation top layer mm | Required crank effort daN | Weight without rope kg |
|----------|----------|--------------------------------------|--------------------------|---------------------|----------------------------------|--|-------------------------------|-------------------------------|---|------------------------------|---------------------------|
| KAL 750 | 30207004 | 750 | 600 | 100 | 6 | 1.3 | 10 | 15 | 17 | 20 | 7 |
| KAL 1120 | 30208000 | 1120 | 600 | 63 | 7 | 0.5 | 10 | 11 | 16 | 22 | 7 |

¹recommended rope: EN 12385 FE-znk 1770 sZ-spa

Dimensions SW-KAL

| Model | KAL 750 | KAL 1120 |
|---------|---------|----------|
| A, mm | 165 | 165 |
| B, mm | 168 | 168 |
| C, mm | 170 | 170 |
| Ø D, mm | 100 | 63 |
| E, mm | 180 | 180 |
| F, mm | 135 | 135 |
| G, mm | 60 | 60 |
| H, mm | 56 | 50 |
| J, mm | 160 | 160 |
| Ø K, mm | 13 | 13 |
| L, mm | 85 | 85 |

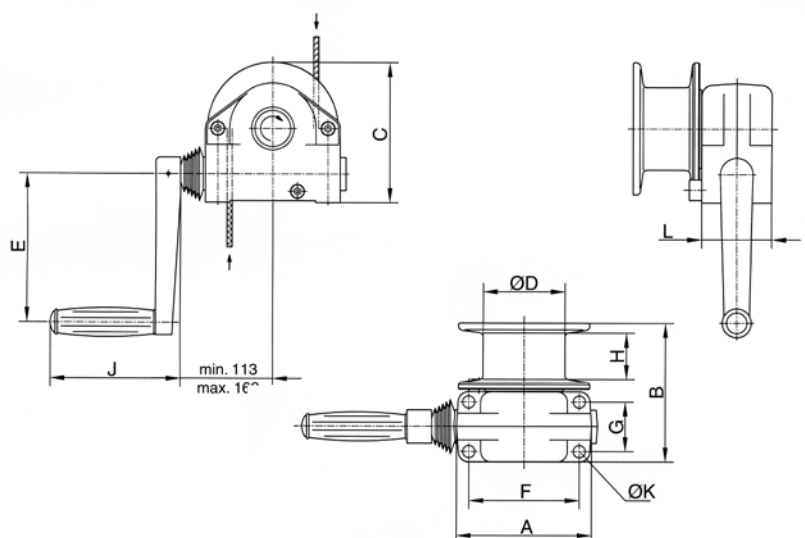

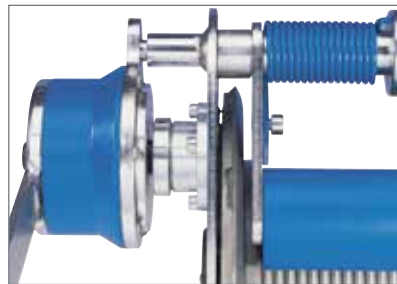

SW-K LAMBDA Console-mounted rope winch DGUV Vorschrift 17 (BGVC1)

Capacity 300 kg

The compact rope winch for applications on stages, in studios, theatres, etc.

Features

- State-of-the-art design with galvanized side sections for easy handling.
- Grooved drum for single-layer winding of the steel rope. An 18:1 ratio between drum and rope diameter increases the service life of the rope substantially.
- With spring-loaded rope pressure roller to prevent the unloaded rope from jumping off the drum.
- Gear rated for twice the nominal load.
- Spur gear drive for optimal efficiency and comfortable handling.
- The fitted safety crank with two spring brakes acting independently of each other for safe holding of the load in any position.
- In compliance with DGUV Vorschrift 17 (BGVC1) and DIN 56925. Certified by the German committee for lifting equipment (GS-approval-tested safety).

Options

- Drum extension for a larger rope capacity.
- Special grooves (several layers)

INFO

Pfaff winches are not designed for passenger elevation applications and must not be used for this purpose.

Technical data SW-K LAMBDA

| Model | Art.-No. | Capacity kg | Rope diameter ¹ mm | Useable rope length 1 st layer m | Lift per crank rotation mm | Required crank effort daN | Weight without rope kg |
|-------------|----------|----------------|----------------------------------|---|-------------------------------|------------------------------|---------------------------|
| SW-K LAMBDA | 30272015 | 300 | 6 | 10 | 50 | 18 | 30 |
| SW-K LAMBDA | 30272017 | 300 | 6 | 15 | 50 | 18 | 36 |

¹recommended rope: EN 12385 FE-znk 1960 sZ-spa

Dimensions SW-K LAMBDA

| Model | SW-K LAMBDA | SW-K LAMBDA |
|---------|-------------|-------------|
| A, mm | 379 | 469 |
| B, mm | 310 | 310 |
| C, mm | 340 | 340 |
| Ø D, mm | 139.4 | 139.4 |
| E, mm | 180 | 270 |
| F, mm | 280 | 280 |
| G, mm | 175 | 265 |
| Ø H, mm | 13 | 13 |
| J, mm | 250 | 250 |
| K, mm | 130 | 130 |

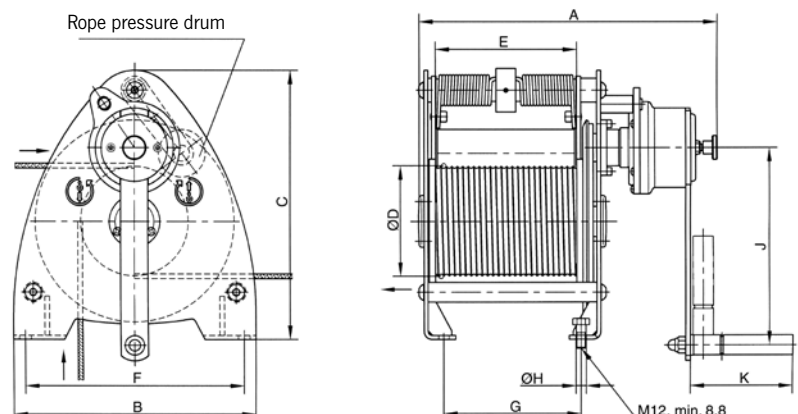

DSRB S Sheave block for rope guidance, equipped with ball bearings



Technical data DSRB

| Model | Art.-No. | Classification FEM/ISO | Pulling force | Pulling force | Rope diameter mm |
|---------------|----------|---------------------------|-------------------------------|--------------------------------|---------------------|
| | | | in kg at deflection 90° | in kg at deflection 180° | |
| DSRB S 90/4 | 33447103 | 2m/M5 | 700 | 500 | 3-4 |
| DSRB S 90/6 | 33447413 | 1Dm/M1 | 700 | 500 | 5-6 |
| DSRB S 145/7 | 33447106 | 1Am/M4 | 1100 | 800 | 7 |
| DSRB S 185/8 | 33447107 | 2m/M5 | 2300 | 1630 | 8 |
| DSRB S 270/12 | 33447111 | 2m/M5 | 2500 | 1800 | 9-12 |

All sheaves are available as an individual component on request.

Dimensions DSRB

| Model | DSRB S 90/4 | DSRB S 90/6 | DSRB S 145/7 | DSRB S 185/8 | DSRB S 270/12 |
|------------|----------------|----------------|-----------------|-----------------|------------------|
| B, mm | 85 | 85 | 125 | 138 | 191 |
| C, mm | 90 | 90 | 160 | 195 | 290 |
| Ø D, mm | 90 | 90 | 145 | 185 | 270 |
| Ø D1, mm | 20 | 25 | 25 | 30 | 40 |
| Ø Dm, mm | 80 | 78 | 126 | 160 | 246 |
| E, mm | 62 | 62 | 88 | 106 | 138 |
| H, mm | 134 | 134 | 224 | 273 | 407 |
| K, mm | 65 | 65 | 110 | 135 | 202 |
| L, mm | 120 | 120 | 200 | 245 | 360 |
| Ø M/M1, mm | 9/9 | 9/9 | 11.5/13 | 13.5/15 | 18/20 |
| S, mm | 4 | 6 | 6 | 8 | 10 |

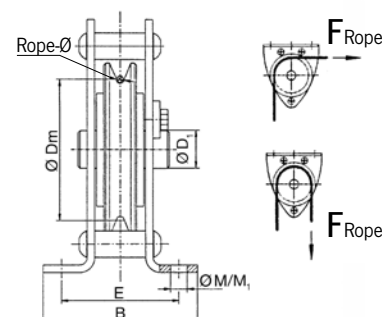
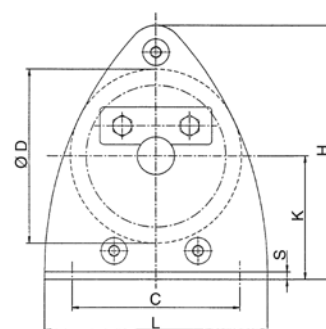

Ex on request!

Standard ropes for manual winches

According to DIN EN 12385-4

(formerly DIN 3060 resp. 3069)

| Rope diameter | Breaking load of rope min. kN | Art.-No. Rope length 5 m | Art.-No. Rope length 10 m | Art.-No. Rope length 15 m | Art.-No. Rope length 20 m | Capacity clevis end kg |
|---------------|-------------------------------------|--------------------------------|---------------------------------|---------------------------------|---------------------------------|------------------------------|
| 4 mm | 10.1 | 33600405 | 33600410 | 33600415 | 33600420 | 500 |
| 5 mm | 15.8 | 33600505 | 33600510 | 33600515 | 33600520 | 1000 |
| 6 mm | 22.8 | 33600605 | 33600610 | 33600615 | 33600620 | 1000 |
| 7 mm | 31.0 | 33600705 | 33600710 | 33600715 | 33600720 | 1000 |

INFO

Additional accessories available on request.



Y 10 ST up to Y 32 ST

Options

- Eye sling hook with safety latch
- Longer ropes
- Drum reel
- Storage box made from steel plate



Yaletrac ST

Cable puller

Pulling force 500 - 3200 daN

The portable Yaletrac ST cable puller is a versatile tool for pulling, lifting, lowering, tensioning and securing loads over long distances. It has been specially designed for applications in industry, building construction, civil engineering, power line construction, ship building and oil refineries etc. The Yaletrac ST cable puller is almost service free – easy to use and safe.

Cable pullers model Yaletrac ST feature a housing of dimensionally stable deep-drawn steel plates ensuring a compact and robust design. The hand operating forces have been noticeably optimised for the user by the application of axial ball bearings.

Features

- Stable upright positioning of the unit due to the combination of handle and foot.
- Space-saving telescopic hand lever that can be safely attached to the unit by means of a hook-and-pile fastener. Short handle lever for Y05 ST not telescopic.
- Overload protection is provided by a shearing pin. Spare shear pins are conveniently located in the carrying handle. A broken pin can be replaced without removing the load.
- Yaletrac ST uses a special flexible rope. It has six strands with a steel core and is identified by an orange strand. The rope is tapered at one end for easy threading and is fitted with an eye sling hook with safety latch on the other end.
- The parallel arrangement of the clamping system protects the rope by distributing the clamping forces evenly. A long rope advance per each lever stroke increases the working speed.
- Increased service life of the unit due to the use of rubber sleeves which prevent dirt and dust from penetrating into the mechanical equipment of the unit.
- Positioning of the forward and reversing levers in tandem provides a slim design and ensures optimal power transfer.
- A lever disengages the rope clamp system allowing easy and smooth installation of the rope.
- The large opening in the top of the unit allows easy cleaning: simply flush the unit with water and apply motor oil for lubrication and the Yaletrac ST is again ready for use.

Technical data *Yaletrac ST*

| Model | Art.-No. | Capacity WLL kg | Rope advance per double stroke in mm | Lever pull at WLL daN | Lever length mm | Rope diameter mm | Weight without rope kg | Rope weight kg/m |
|----------------------|-----------|-----------------|--------------------------------------|-----------------------|-----------------|------------------|------------------------|------------------|
| Y 05 ST ¹ | 192043685 | 500 | 20 | 30 | 260 | 6.0 | 2.8 | 0.10 |
| Y 10 ST | N02400009 | 1000 | 60 | 23 | 800 | 8.4 | 8.5 | 0.29 |
| Y 16 ST | N02400010 | 1600 | 60 | 28 | 790/1190 | 11.2 | 15.8 | 0.53 |
| Y 32 ST | N02400011 | 3200 | 40 | 46 | 790/1190 | 16.0 | 27.2 | 1.00 |

¹see complete scope of delivery

Dimensions *Yaletrac ST*

| Model | Y 05 ST | Y 10 ST | Y 16 ST | Y 32 ST |
|--------|---------|---------|---------|---------|
| L, mm | 285 | 435 | 560 | 664 |
| H, mm | 116 | 178 | 205 | 240 |
| H1, mm | 164 | 235 | 280 | 350 |
| B, mm | 48 | 61 | 86 | 96 |
| B1, mm | 70 | 94 | 125 | 123 |

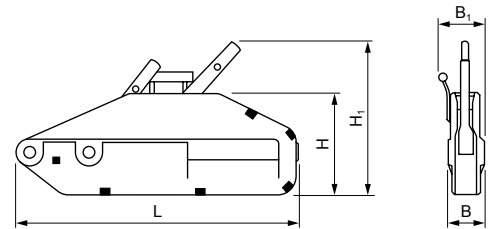

MODEL UPGRADING
**NOW ALSO AVAILABLE:
 500 daN PULLING FORCE!
 FOR MOBILE USE**



Option only for *Yaletrac 05 ST*
 Useful shoulder bag



Y05 ST

Scope of delivery

- Cable puller 500 kg capacity
- Hand lever
- Wire rope Ø 6 mm, 10 m
- Eye sling hook with safety latch
- Webbing sling HSE 00500

Option

- Shoulder bag



Model *Yaletrac 05 ST*
 Assembled and ready for operation (installed)

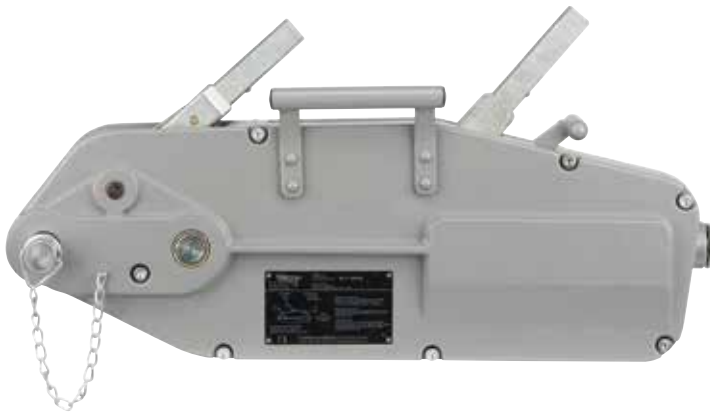

Yaletrac Cable puller

Pulling force 800 - 3200 daN

It has a light weight, compact, high tensile aluminium alloy housing with a large flat bottom surface for increased stability in horizontal as well as vertical working position.

Features

- Forward and reversing levers in tandem provide slim design and assure power transfer along the centre line.
- Overload protection is by a shearing pin in the forward lever. Spare shear pins are conveniently located in the carrying handle or operating lever. A broken pin can be replaced without removing the load.
- A lever disengages the rope clamp system allowing easy, smooth installation of the rope.
- Yaletrac uses a special flexible rope. It has six strands with a steel core and is identified by an orange strand. The rope is tapered at one end for easy threading and fitted with an eye sling hook with safety latch on the other end.
- The parallel arrangement of the clamping system protects the rope by distributing the clamping forces evenly. A long rope advance per each lever stroke increases the working speed.
- The large opening in the top of the unit allows easy cleaning: simply flush the unit with water, apply motor oil for lubrication and the Yaletrac is again ready for use.

Options

- Eye sling hook with safety latch
- Longer ropes
- Drum reel
- Storage box



Option:
Eye sling hook with safety latch



Option:
Yaletrac storage box made from steel plate,
approx. 74 x 26 x 45 cm

Technical data Yaletrac

| Model | Art.-No. | Capacity WLL kg | Rope advance per double stroke mm | Lever pull at WLL daN | Lever length mm | Rope diameter mm | Weight without rope kg | Rope weight kg/m |
|-------|-----------|-----------------|-----------------------------------|-----------------------|-----------------|------------------|------------------------|------------------|
| Y 08 | N02409053 | 800 | 60 | 24 | 800 | 8.4 | 7 | 0.29 |
| Y 16 | N02409054 | 1600 | 60 | 30 | 790/1190 | 11.2 | 14 | 0.53 |
| Y 32 | N02409055 | 3200 | 40 | 50 | 790/1190 | 16.0 | 21 | 1.00 |

Dimensions Yaletrac

| Model | Y 08 | Y 16 | Y 32 |
|--------|------|------|------|
| L, mm | 430 | 545 | 680 |
| H, mm | 168 | 190 | 230 |
| H1, mm | 240 | 270 | 330 |
| B, mm | 60 | 72 | 91 |
| B1, mm | - | 97 | 110 |

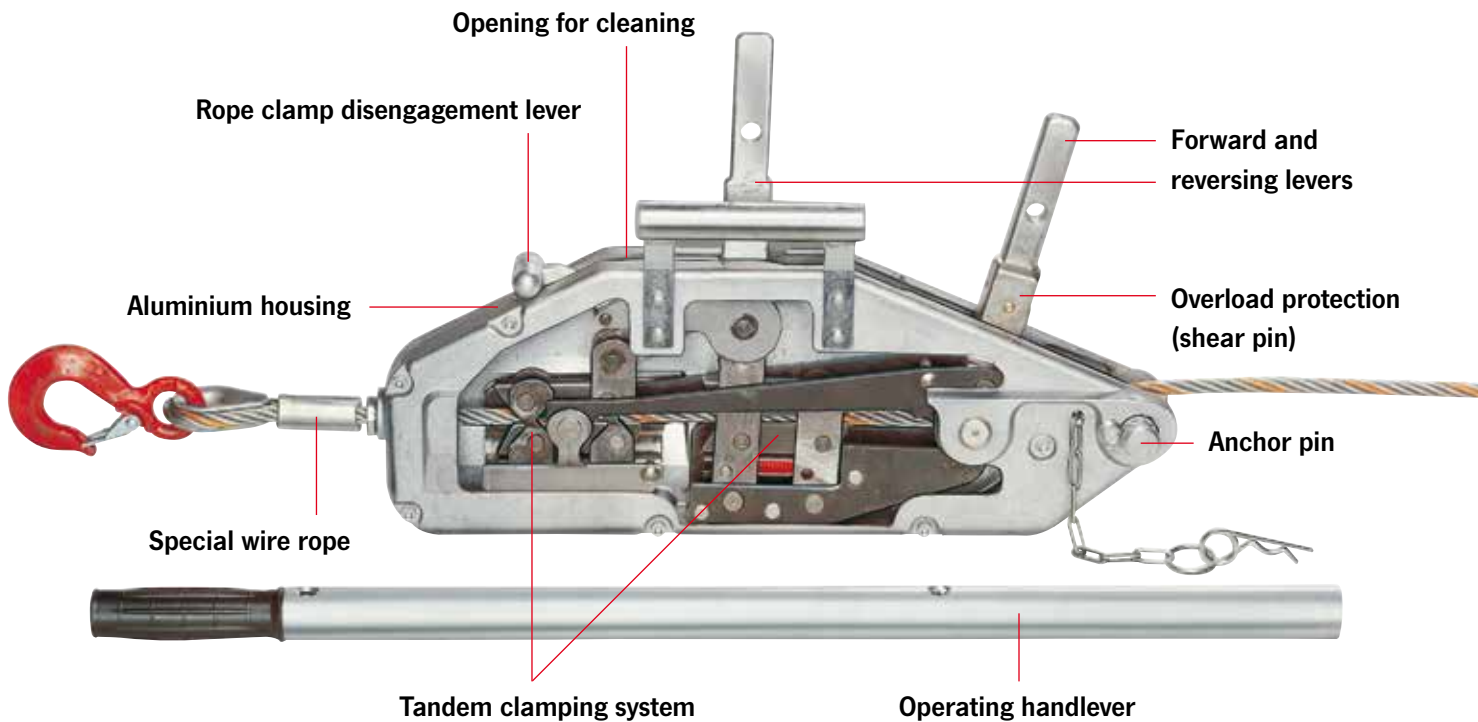
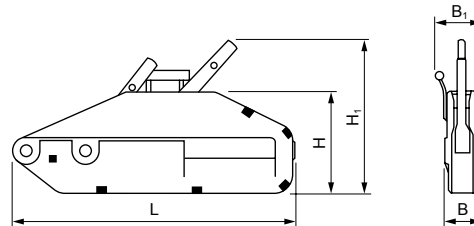

INFO

Yale hoists and trolleys are not designed for passenger elevation applications and must not be used for this purpose.

Complementary products available like cable grips (see page 100), pulley blocks (see page 101) and textile slings (see pages 234-239).



LMG Cable grip

Pulling force 2000 - 5000 daN

The LITTLE MULE® cable grip is a device for gripping, pulling and tensioning uncoated wire ropes, cables and metal rods in all forms up to a tensile strength of 1770 N/mm² but is dependant on the diameter and surface condition.

The parallel jaws provide a firm, non-slip grip without causing damage to the wire rope. A special spring-loaded guide prevents the grip from dropping off the wire rope and allows instant release without jamming.

LMG I-X und LMG II-X are supplied with grooved jaws and are suitable for wire ropes with a tensile strength of up to 1960 N/mm², but is dependant on the rope diameter and surface condition.

INFO

Yale hoists and trolleys are not designed for passenger elevation applications and must not be used for this purpose.

Technical data LMG

| Model | Art.-No. | Pulling force daN | For rope diameter mm | Eye opening mm | Weight kg |
|----------|-----------|-------------------|----------------------|----------------|-----------|
| LMG I | N02606516 | 2000 | 4.5 - 15 | 31 x 44 | 1.6 |
| LMG I-X | N02608042 | 2000 | 5 - 15 | 31 x 44 | 1.6 |
| LMG II | N02606517 | 3000 | 8 - 20 | 31 x 44 | 2.9 |
| LMG II-X | N02608043 | 3000 | 8 - 20 | 31 x 44 | 2.9 |
| LMG III | N02607609 | 5000 | 18 - 32 | 66 x 93 | 9.5 |

Pulley blocks, hinged, with single steel sheave

Capacity 1000 - 6400 kg

One side of the Yale pulley blocks is hinged and can be opened for easy and quick positioning of the wire rope on the sheave. It can also provide a quick and versatile rigging point or redirect a wire rope.

Features

- Swinging the hook in the direction of pull securely locks the pulley block.
- The high quality cast steel sheaves have machined grooves and are fitted with Permaglide[®] bushes.



INFO

When choosing and classifying pulley blocks, take the "Grundsätze für Seiltriebe" DIN 15020 into consideration.

Technical data Pulley blocks

| Model | Art.-No. | Capacity kg | Roller diameter mm | Rope diameter mm | Weight kg |
|-------------------|-----------|-------------|--------------------|------------------|-----------|
| Pulley block 1000 | N46000005 | 1000 | 85 | 7 | 3.3 |
| Pulley block 2000 | N46000003 | 2000 | 150 | 13 | 8.9 |
| Pulley block 3200 | N46000004 | 3200 | 180 | 15 | 15.5 |
| Pulley block 6400 | N46000006 | 6400 | 210 | 18 | 26.5 |

Dimensions Pulley blocks

| Model | Pulley block 1000 | Pulley block 2000 | Pulley block 3200 | Pulley block 6400 |
|----------|-------------------|-------------------|-------------------|-------------------|
| B, mm | 118 | 199 | 230 | 270 |
| B1, mm | 76 | 92 | 108 | 116 |
| B2, mm | 17 | 24 | 28 | 35 |
| C, mm | 23 | 27 | 31 | 42 |
| Ø D1, mm | 85 | 150 | 180 | 210 |
| Ø D2, mm | 105 | 190 | 220 | 260 |
| L, mm | 305 | 425 | 496 | 655 |
| L1, mm | 200 | 263 | 295 | 375 |
| L2, mm | 23 | 30 | 40 | 47 |
| R, mm | 4 | 7 | 9 | 10 |

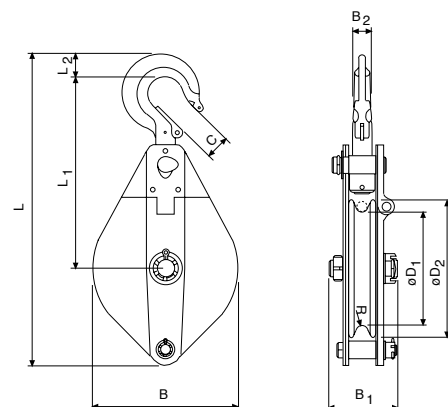

INFO

Yale hoists and trolleys are not designed for passenger elevation applications and must not be used for this purpose.



Steel rope for manual and electric winches

All electric winches are supplied without load bearing mechanisms as standard. To ensure safe operation an optimum rope design, optimum length and associated fastening elements (hooks, shackles) are selected.

We recommend to choose wire ropes on the basis of design, type of construction and strength to suit the intended use and frequency of use. The features of the different types of rope design are as follows:

Breaking load

→ Load bearing capacity, strength of the rope

Bending fatigue + flexibility

→ Service life

External wear

→ Stability of the outer strands

Torsion characteristics

→ Lifting of guided or unguided loads

Handling

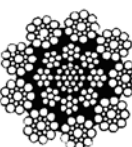
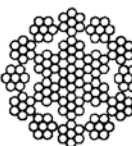
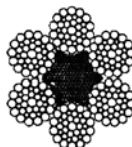
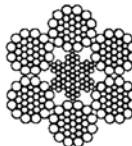
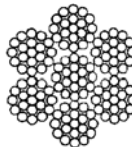
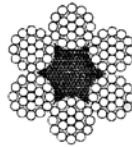

Our product range includes winches for lifting, pulling and moving of loads. In combination to our winches the following rope types apply:

Standard design

6 x 19 + FE 1770 N/mm²

Manual winch rope with fiber inlay 3 - 12 mm Ø

Galvanized or stainless steel in mat. 1.4401

Nominal strength 1570 N/mm² (low breaking load)

- not non-twisting
- crosslay type of construction
- low-tension
- lifting rope for infrequent actuation
- rugged and widely resistant

Warrington-Seale

6 x 36 WS + SES (FE) 1770 N/mm²

Manual and electric winch rope in parallel type of construction 10 - 28 mm Ø

Galvanized, with fiber or steel inlays as options

- highly flexible
- high breaking load
- average number of reversed bending stresses

Non-rotating special rope

SE-znk - 1960 N/mm²

Standard rope for electric winches, non-rotating spiral strand rope 3 - 13 mm Ø

Galvanized

- balanced characteristics
- lifting rope for unguided single rope suspension elements
- lifting rope for large lifting heights with multiple rope suspension elements
- not to be used with a swivel
- high strength
- high bending fatigue characteristics

Heavy duty winch rope

Electric winch rope with plastic-coated steel core in double-parallel type of construction 6 - 30 mm Ø

Bright and greased, not non-twisting

- special rope for frequent bending stress reversals and long use
- to be used only with matching rope sheaves and drums
- optimized break loads due to higher fill factor

INFO

The use of plastic-coated steel wire ropes with lifting equipment is not permitted.

To meet individual requirements we can provide assistance for the selection of length, diameter and type of the rope, as well as a fastening equipment (thimbles, hooks, rope clips, etc.).

Rope fasteners/rope connections

The safe functioning of the rope drive depends to a large extent on the rope fastenings on the winch and on the load. Rope connections and ropes themselves have to be checked at regular intervals by competent persons. The following rope connections are permissible for use with lifting equipment:

Non-releasable rope connections

Aluminium press-on connection
with thimbles

in combination with safety eye hooks or screw shackles provide a simple and safe means of suspending loads.

Splice connections (uncoated)
in combination with thimbles, hooks, etc.

In the most unfavourable situation, splice connections can lead to a reduction in the breaking load of the rope line of up to 40%.

Releasable rope connections

Rope clips

- The end which is not under load must never be fastened to the load-bearing line.
- The length of the unloaded rope end should be at least 20 times the diameter of the rope and not less than 150 mm.
- Clips may no longer be used once the rope has worn by more than 10%.
- Wire rope clamps may not be used for rope connections for lifting equipment, with the exception of fastening equipment which is manufactured for non-recurring, special purposes!

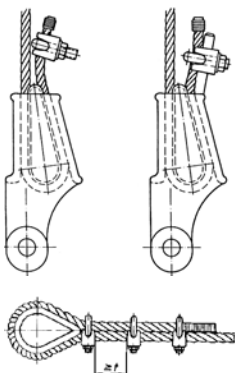
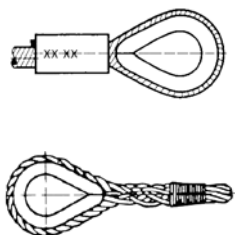

Handling of ropes – Unwinding

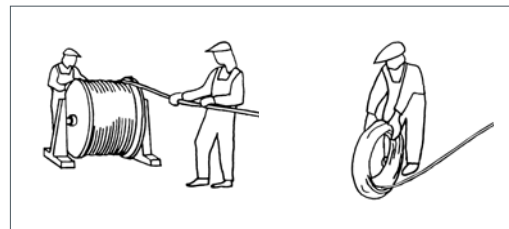

RIGHT

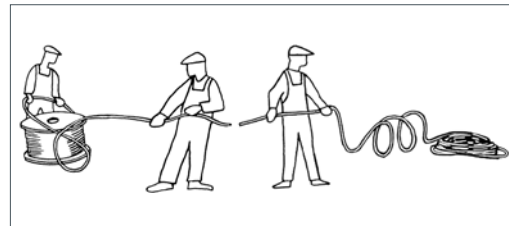

WRONG

Care of ropes

“Running ropes” in particular will only offer optimum service lives if they are well lubricated. The use of steel ropes without grease will cause them to wear quickly and the load bearing mechanism will have to be replaced early.

INFO

Pressed and splice connections may only be produced by specialist firms or rope manufacturers.

Notes on the installation of winches

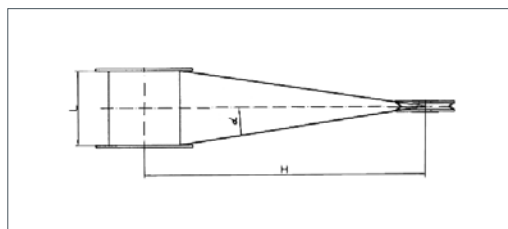

The distance between rope drum and sheave must be selected in a way that the maximum deflection angle for the type of rope used is not exceeded:

Standard rope – Deflection angle <math>< 3^\circ</math>
(Minimum distance = Drum width x 10)

Special rope - Deflection angle <math>< 1.5^\circ</math>
(Minimum distance = Drum width x 20)

- To prevent the wire rope from becoming slack when unloaded it should always have an additional rope weight when used with lifting equipment
- Guided loads must be monitored with a slack rope cut-out.
- To prevent the rope from becoming damaged, steel wire ropes must never be guided
 - over edges
 - over deflection radii which are too small or
 - over rope sheaves with grooves which are too small.
- High dynamic forces can lead to sudden breaks or crashes of the load. It is therefore imperative that loads are never brought to a dead stop (“on block”) and that loads are never allowed to drop into the rope.



The image shows the winch RPE up to 1,0t

Yale *RPE*

Electric winch

Capacity 250 - 2000 kg

Winches series RPE are designed for performance, efficiency and safety and offer many advantages and options. RPE's compact, practical cube design and universal rope lead-offs allow individual applications in almost any position for lifting and pulling loads.

The winches are designed to DIN 15020, classification 1 Bm/M3 and the EC machinery directives.

Every winch is factory tested with overload. The units are supplied with a test certificate showing the unit's serial-no. and an operating instructions manual which contains a manufacturer's declaration.

Features

- Compact dimensions due to internal brake motor.
- Standard operating voltages of 400V/230V, 3-ph, 50 Hz or 230V, 1-ph, 50 Hz
- Protected to IP 54
- Insulation class F
- Adjustable slip clutch to protect the winch from overloading standard for RPE 10-6 and RPE 20-6.
- Spur gear transmission with helical first gear ensures smooth motion. Lubricated by grease and can, therefore, be used in any position.
- Spring pressure disc brake incorporated in the motor holds the load secure even in the event of a power failure.
- Plain rope drum standard. The rope is secured to the drum in a recess so that the rope can be wound onto the drum in several layers without damage.
- 42V low voltage control (incl. push-button with emergency-stop and 2m control cable) or without controls.



Rope attachment



Spring pressure disc brake



Brake motor

INFO

When selecting the length of the rope please bear in mind that a minimum of 2-3 windings have to remain on the drum.

The wire rope, if ordered, comes dismantled, and is to be mounted onto the drum by the user.

Please note, the single-phase winches generate a higher noise level than those with three-phase motors.

Options

- Different drum designs (XL) extended to accommodate longer rope.
- Machined grooved drums for better rope reeling.
- Drums with separation web and extra rope outlets for working with two or more ropes.
- Geared limit switches to limit rope motion in both directions (in combination with 42 V low voltage control).
- Slack rope switch to automatically stop the winch when rope tension eases e.g. when the load touches down (in combination with 42 V low voltage control)
- Frequency converter for stepless speed control.
- Special design according to DGUV Vorschrift 17 (BGVC1) for theater stage applications on request.
- Radio remote control only in combination with low voltage control
- Other operating voltages
- Motor brakes with manual release.
- Special coatings or zinc plated finish.

The image shows the winch RPE 20-6 with the grooved drum (optional).



Single-phase A.C. motor



Geared limit switches



Gearbox with slip clutch



Different drum designs



INFO

Also available as zinc-plated version on request!

Technical data RPE

| Model | Capacity kg | Lifting speed m/min | | Rope layers max. | Rope diameter mm | Motor kW | ED | Weight without rope kg | |
|-------------------------|----------------|------------------------|-----------|------------------------|------------------------|-------------|-----|---------------------------|-----|
| | | 1 st layer | top layer | | | | | L | XL |
| RPE 2-13 L | 250 | 10.2 | 13.2 | 4 | 4 | 0.55 | 40% | 40 | 48 |
| RPE 5-6 L | 500 | 4.6 | 6.6 | 4 | 6 | 0.55 | 40% | 41 | 49 |
| RPE 5-12 L | 500 | 8.7 | 12.6 | 4 | 6 | 1.1 | 40% | 47 | 54 |
| RPE 10-6 L ¹ | 1000 | 5.1 | 6.5 | 3 | 8 | 1.1 | 40% | 89 | 105 |
| RPE 20-6 ¹ | 2000 | 5.2 | 7.6 | 3 | 12 | 2.2 | 40% | 213 | 235 |

¹Adjustable slip clutch as standard



INFO

When selecting the length of the rope please bear in mind that a minimum of 2-3 windings have to remain on the drum.

Yale hoists and trolleys are not designed for passenger elevation applications and must not be used for this purpose.

Plain drum rope capacity

| Model | Capacity top layer kg | Drum size | Useable rope length max. m | | | |
|-----------------------|-----------------------------|----------------|-------------------------------|-----------------------|-----------------------|-----------------------|
| | | | 1 st layer | 2 nd layer | 3 rd layer | 4 th layer |
| RPE 2-13 ¹ | 250 | 1 ¹ | 11.1 | 24.5 | 39 | 54 |
| RPE 5-6 ¹ | 500 | 1 ¹ | 7.4 | 16.9 | 27 | 38 |
| RPE 10-6 ¹ | 1000 | 1 ¹ | 10.1 | 23.0 | 37 | - |
| RPE 20-6 | 2000 | 1 | 13.2 | 30.3 | 49 | - |
| RPE 2-13 L | 250 | 2 | 16.8 | 36.4 | 57 | 80 |
| RPE 5-6 L | 500 | 2 | 11.3 | 25.2 | 40 | 57 |
| RPE 5-12 L | 500 | 2 | 11.3 | 25.2 | 40 | 57 |
| RPE 10-6 L | 1000 | 2 | 15.8 | 35.2 | 56 | - |
| RPE 20-6 L | 2000 | 2 | 20.6 | 46.1 | 74 | - |
| RPE 2-13 XL | 250 | 3 | 44.3 | 94.1 | 148 | 200 |
| RPE 5-6 XL | 500 | 3 | 30.0 | 65.5 | 105 | 149 |
| RPE 5-12 XL | 500 | 3 | 65.0 | 65.5 | 105 | 149 |
| RPE 10-6 XL | 1000 | 3 | 30.7 | 67.0 | 107 | - |
| RPE 20-6 XL | 2000 | 3 | 34.1 | 74.9 | 120 | - |

¹available on request only!

Grooved drum rope capacity (recommended for single layer operation)

| Model | Capacity top layer kg | Drum size | Useable rope length m | |
|-------------------------|-----------------------------|----------------|--------------------------|------|
| | | | 1 st layer | max. |
| RPE 2-13 R ¹ | 250 | 1 ¹ | 8.8 | 43 |
| RPE 5-6 R ¹ | 500 | 1 ¹ | 6.2 | 33 |
| RPE 10-6 R ¹ | 1000 | 1 ¹ | 8.2 | 30 |
| RPE 20-6 R | 2000 | 1 | 12.0 | 44 |
| RPE 2-13 LR | 250 | 2 | 13.3 | 64 |
| RPE 5-6 LR | 500 | 2 | 9.5 | 49 |
| RPE 5-12 LR | 500 | 2 | 9.5 | 49 |
| RPE 10-6 LR | 1000 | 2 | 12.9 | 47 |
| RPE 20-6 LR | 2000 | 2 | 16.8 | 61 |
| RPE 2-13 XLR | 250 | 3 | 35.3 | 165 |
| RPE 5-6 XLR | 500 | 3 | 25.7 | 128 |
| RPE 5-12 XLR | 500 | 3 | 25.7 | 128 |
| RPE 10-6 XLR | 1000 | 3 | 25.2 | 89 |
| RPE 20-6 XLR | 2000 | 3 | 27.9 | 99 |

¹available on request only!

Dimensions RPE (400 V direct control, standard drum)

| Model | RPE 2-13 ¹ RPE 5-6 ¹ | RPE 2-13 L RPE 5-6 L RPE 5-12 L | RPE 2-13 XL RPE 5-6 XL RPE 5-12 XL | RPE 10-6 ¹ | RPE 10-6 L | RPE 10-6 XL | RPE 20-6 | RPE 20-6 L | RPE 20-6 XL |
|-----------------------|---|---------------------------------------|--|-----------------------|------------|-------------|----------|------------|-------------|
| A, mm | 405 | 405 | 405 | 525 | 525 | 525 | 670 | 670 | 670 |
| B, mm | 375 | 375 | 375 | 485 | 485 | 485 | 550 | 550 | 550 |
| C, mm | 18 | 18 | 18 | 25 | 25 | 25 | 36 | 36 | 36 |
| D _{TR} , mm | 76 | 76 | 76 | 108 | 108 | 108 | 146 | 146 | 146 |
| D _{max} , mm | 104 | 118 | 118 | 148 | 148 | 148 | 224.4 | 224.4 | 224.4 |
| DA, mm | 150 | 150 | 150 | 180 | 180 | 180 | 245 | 245 | 245 |
| E, mm | 338 | 428 | 865 | 450 | 575 | 902 | 619 | 784 | 1084 |
| F, mm | 210 | 300 | 737 | 270 | 395 | 722 | 360 | 525 | 825 |
| G, mm | 260 | 350 | 787 | 345 | 470 | 797 | 480 | 645 | 945 |
| H, mm | 290 | 380 | 817 | 380 | 505 | 832 | 540 | 705 | 1005 |
| I, mm | 11 | 11 | 11 | 13 | 13 | 13 | 23 | 23 | 23 |
| K, mm | 250 | 250 | 250 | 340 | 340 | 340 | 401 | 401 | 401 |
| L, mm | 125 | 125 | 125 | 170 | 170 | 170 | 215 | 215 | 215 |
| M, mm | 6 | 6 | 6 | 10 | 10 | 10 | 15 | 15 | 15 |
| N, mm | 33 | 33 | 33 | 47.5 | 47.5 | 47.5 | 72.5 | 72.5 | 72.5 |
| O, mm | 194 | 284 | 721 | 250 | 375 | 702 | 335 | 500 | 800 |
| P, mm | 19 | 19 | 19 | 24 | 24 | 24 | 34 | 34 | 34 |
| Q, mm | 13 | 13 | 13 | 19 | 19 | 19 | 26 | 26 | 26 |
| R, mm | 125 | 125 | 125 | 170 | 170 | 170 | 135 | 135 | 135 |
| S, mm | 4 | 6 | 6 | 8 | 8 | 8 | 12 | 12 | 12 |
| α 1, ° | 130 | 130 | 130 | 145 | 145 | 145 | 153 | 153 | 153 |
| α 2, ° | 110 | 110 | 110 | 125 | 125 | 125 | 136 | 136 | 136 |
| α 3, ° | 40 | 40 | 40 | 50 | 50 | 50 | 64 | 64 | 64 |
| β 1, ° | 150 | 150 | 150 | 155 | 155 | 155 | 147 | 147 | 147 |
| β 2, ° | 90 | 90 | 90 | 100 | 100 | 100 | 107 | 107 | 107 |
| β 3, ° | 80 | 80 | 80 | 83 | 83 | 83 | 83 | 83 | 83 |

¹available on request only!

Dimensions for models with optional features are available on request!

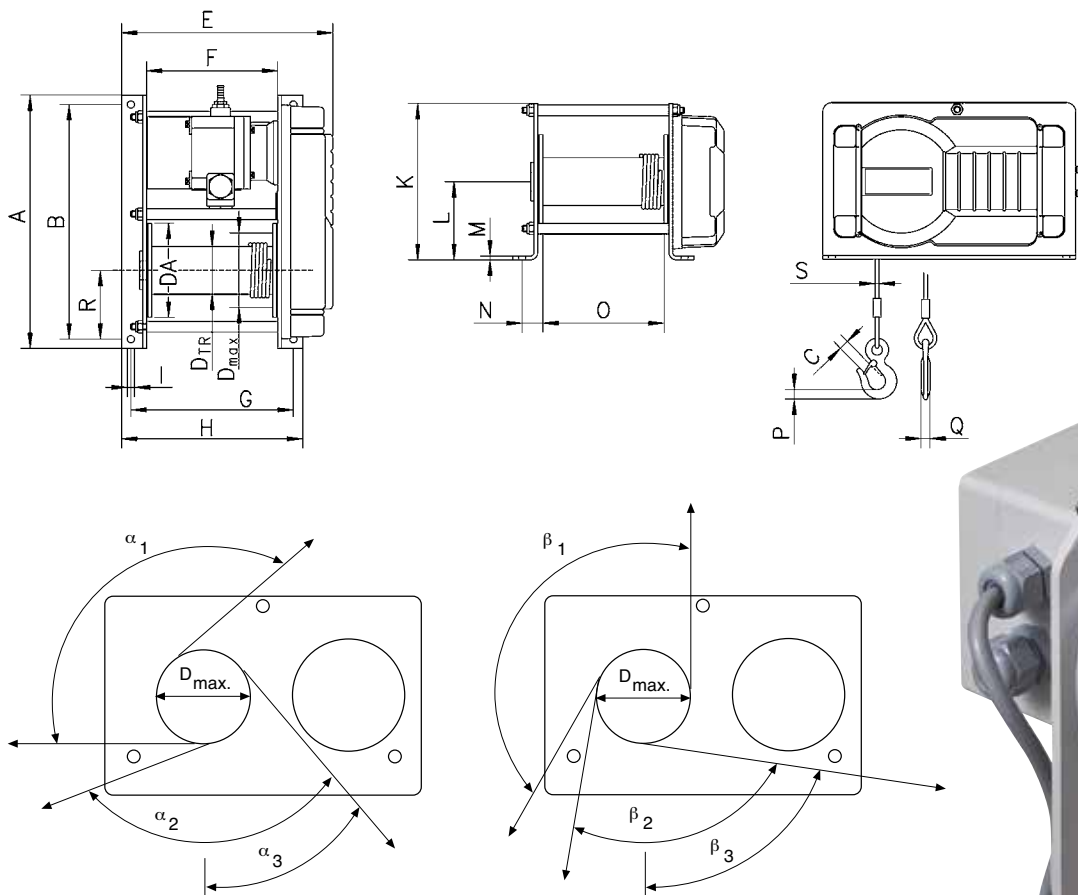

Rope lead-offs for electric winch RPE

*Endless winch
up to 500 kg!*



STANDARD
This image shows the
Yale Mtrac winch with
standard equipment.

PATENTED*
BI-DIRECTIONAL ACTUATOR
FOR BI-DIRECTIONAL
LIFTING

*German Patent DE 10 2012 100 099

Yale Mtrac®

Endless winch

Capacity 66 - 500 kg

(two-fall design up to 1000 kg, optional)

The Yale Mtrac® endless winch combines state-of-the-art industrial design with technical innovation to solve a specific customer need – the need for a safe and simple handling solution for mobile applications.

We did just that. Because the rope of the endless winch is not collected during operation, there is no limit to the lifting height and traction length when using this product. And, with a full offering of wire ropes and accessories, this winch can be used in virtually any application requiring a hoist., e.g. on construction sites, in maintenance and assembly, in wind mills and power supply, water and utility sector, overhead line maintenance, etc.

Features

- Control pendant (IP 65-type of enclosure) is connected via a control cable.
- Standard power cable has a length of 1.0m and is fitted with a CE connector plug (or a Schuko-plug).
- 42V low-voltage control
- Ergonomic, fitted carrying handle features a comfortable plastic grip.
- Mounting feet fixed on the housing for easy set up.
- Standard operating voltages of 400V, 3-ph, 50Hz or 230V, 1-ph, 50Hz.
- Galvanized, high-density steel rope is 10 m long (dia. 6.5 mm) and features a safety hook on one end as well as a rounded, plastic-coated tip at the loose end.
- Two spring buffers with adjusting rings can be attached to the wire rope to set the limit switches for both upward and downward movement.
- Drive sheave is made of especially hardened steel designed to ensure long service life.
- The patented (German Patent DE 10 2012 100 099) bi-directional actuator ensures the rope is safely guided and securely held in place.
- Slip clutch is located outside of the load path for added safety.
- Limit switches ensure safe cut-out for the upper and lower hook positions.
- Electromagnetic brake holds the load safely, even in the event of a power failure.
- Winch is classified up to 1 Bm/M3 acc. to FEM/ISO.
- Winch is protected up to IP 55.

FEATURES

PATENTED* BI-DIRECTIONAL ACTUATOR

The Yale *Mtrac* endless winch features a unique bi-directional actuator that allows the winch to move the rated load on both ends of the rope. A hook can be fitted on the unloaded rope end (as an option) thus eliminating no-load motions. How does it work? Once the load has reached the top position, the unloaded rope end with the other hook is automatically in the bottom position and a new load can be picked up immediately. The lifting frequency is doubled as the two falls can be evenly loaded alternately with the rated load.

*German Patent DE 10 2012 100 099

READY TO USE

Each winch leaves our factory as a complete plug and play unit.

The control cable with control pendant is connected, as is the power supply cable with the plug. The standard design also features a wire rope complete with fitted safety hook. The carrying handle is included as standard and load-bearing feet are provided on the lower part of the housing.

STATE-OF-THE-ART INDUSTRIAL DESIGN

A compact and state-of-the-art design was at the focus of the Yale *Mtrac*. The housing is made of low-pressure, die-cast aluminum and the high-strength, glass-fiber reinforced plastic covers ensure low weight and outstanding rigidity. A carrying frame, available as an option, allows for easy, two-person transport and provides additional protection against damage when moving the unit or operating it in rough conditions.

VERSATILE APPLICATION

Mtrac winches can be used vertically, at an angle or horizontally for versatility depending on your application. Optionally, the load capacity can be doubled with two-fall reeving. Bolting points on the housing allow the customer to attach the winch in a way that best suits their application.

PROVEN TECHNOLOGY

Mtrac winches include reliable and proven Yale technology. The oil-bath lubricated and case-hardened gearbox has a helical gearing for smooth operation and a long service life. IP 55-rated motor enclosure ensures reliable operation of the winch for both indoor and outdoor applications.

BEST-IN-CLASS SAFETY

Standard winch models feature 42 V low-voltage control with built-in limit switches designed to stop the hoist when the hook has reached the upper or lower position. The operator can define the limit switch positions by simply relocating the spring buffers on the rope. The winch is also protected against overload by means of a slip clutch that is designed to guarantee a permanent connection between the load and the brake.

SIMPLE MAINTENANCE

Yale *Mtrac* winches are easy to service. Units are designed with a modular structure with all critical parts easily accessible. Re-adjusting the slip clutch and inspecting the brake is quick and easy as well. In addition, the handle, or carrying frame, can be quickly and easily assembled and removed.

ERGONOMIC DESIGN

Standard units have a comfortable plastic grip that allows for convenient one-person transport. The optional carrying frame features a grip on each handle, making two-person transport easy. And, because of the rounded housing, operator injury is minimized.



STANDARD
This image shows the Yale *Mtrac* winch with standard equipment.



Capacity up to 1000 kg

TWO-FALL DESIGN
with optional components such as suspension hook and bottom block.

OPTIONAL FEATURES

BI-DIRECTIONAL LIFTING

To realize the full potential of this winch, operators can utilize the bi-directional actuator. Simply fit an additional hook at the loose rope end to take advantage of this unique feature. Once the hook is in place, the unit can be used in bi-directional lifting mode (two-hook mode). The actuator is mounted in the interior of the winch and ensures the rope smoothly runs in the drive sheave. It also extends the pressure surface of the rope on the drive sheave for safe friction contact. The two load falls are designed to alternately carry the rated load.

CARRYING FRAME

The carrying frame on the Yale *Mtrac* can be installed either at the top or at the bottom on the unit. It is ergonomically designed with plastic grips that ensure hand-friendly handling and carrying of the winch by two people. The carrying frame cannot be used as a load-bearing component; it is exclusively intended to protect the housing, e.g. while working, during storage or while transporting or carrying the winch. Two carrying frames can also be used (one at the top and one at the bottom).

CONNECTION TO TROLLEYS

If low headroom is required, the Yale *Mtrac* winch can be easily converted from the standard hook connection to a trolley mount using a Yale trolley. Manual and power-driven trolleys available on request.

Yale *Mtrac* winches with two carrying frames (optional) are extremely well protected and can be safely operated in any position.



The accessories for the two-part reeved option double the load capacity.



OPTIONAL

- The transport and carrying frames are designed to protect the housing.
They must not be used as load-bearing components!
- Two-part reeving configuration doubles the load capacity.
- Additional hook kit for bi-directional lifting.
- Special voltages on request.
- Steel wire ropes of various lengths.
- Manual and electric trolleys.
- Frequency converter for variable speed control or smooth starting.
- Operating hours counter to determine the remaining service life and number of switching operations.
- Radio remote control with extended operation range.
- Varying lengths for power and control cables.
- Stainless steel wire ropes (with shorter service life than standard).

PATENTED*
BI-DIRECTIONAL ACTUATOR
FOR BI-DIRECTIONAL LIFTING

*German Patent DE 102012 100099



Optional:
Radio remote control

BI-DIRECTIONAL LIFTING

This image shows the Yale Mtrac's optional second hook that allows for bi-directional lifting operation.

The hooks of the two rope falls can be alternately loaded with 100% rated load.

BI-DIRECTIONAL LIFTING

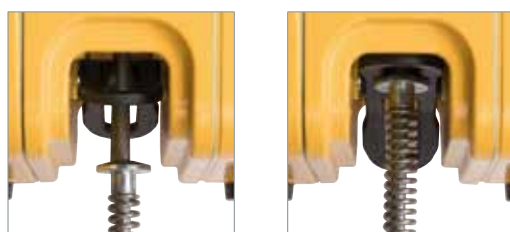

LIMIT SWITCHES AND LIMIT SWITCH ACTUATOR

The spring buffers attached to the rope trip the limit switch actuator when they contact the paddle, which in turn actuates the micro-switches that stop the hoisting motion (via the low voltage control).

Technical data YaleMtrac

| Model | Art.-No. | Single fall Standard | | Double fall Optional | | Motor kW | Operating voltage |
|-------------|-----------|-------------------------|---------------|-------------------------|---------------|-----------------|-------------------|
| | | Capacity | Lifting speed | Capacity | Lifting speed | | |
| | | kg | m/min | kg | m/min | | |
| YMT 1-15 | 192025166 | 100 | 15 | 200 | 7.5 | 0.37 | 230V/1 Ph/50 Hz |
| YMT 3-5 | 192025170 | 300 | 5 | 600 | 2.5 | 0.37 | 230V/1 Ph/50 Hz |
| YMTF 0,6-30 | 192025175 | 66 | 30/7.5 | 130 | 15/3.7 | 0.37/0.09 | 400V/3 Ph/50 Hz |
| YMT 1-30 | 192025171 | 100 | 30 | 200 | 15 | 0.55 | 400V/3 Ph/50 Hz |
| YMTF 2-10 | 192025176 | 200 | 10/2.5 | 400 | 5/1.3 | 0.37/0.09 | 400V/3 Ph/50 Hz |
| YMT 3-10 | 192025174 | 300 | 10 | 600 | 5 | 0.55 | 400V/3 Ph/50 Hz |
| YMT 5-5 | 192053140 | 500 | 5 | 1000 | 2.5 | 0.55 | 400V/3 Ph/50 Hz |

Weight from 24 to 26 kg (without rope) depending on options.

Rope Ø 6.5 mm

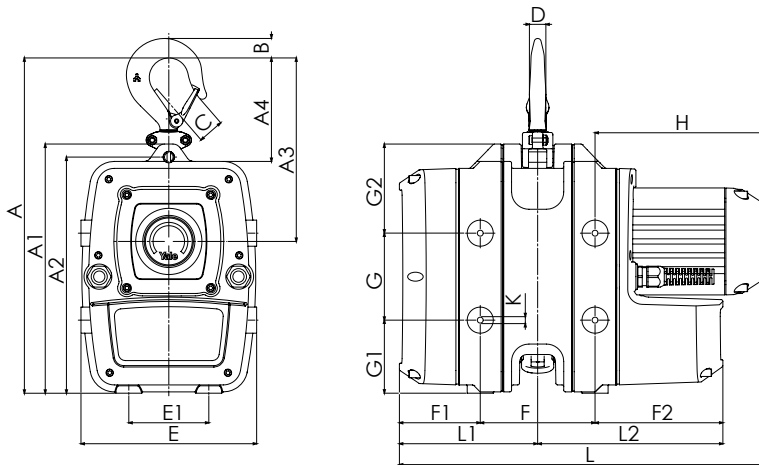

| Dimensions | |
|------------|-----|
| A, mm | 385 |
| A1, mm | 287 |
| A2, mm | 272 |
| A3, mm | 221 |
| A4, mm | 119 |
| B, mm | 22 |
| C, mm | 29 |
| D, mm | 19 |
| E, mm | 202 |
| E1, mm | 92 |
| F, mm | 132 |
| F1, mm | 93 |
| F2, mm | 147 |
| G, mm | 100 |
| G1, mm | 84 |
| G2, mm | 103 |
| H, mm | 201 |
| K, mm | M8 |
| L, mm | 426 |
| L1, mm | 159 |
| L2, mm | 213 |



INFO

Yale hoists and trolleys are not designed for passenger elevation applications and must not be used for this purpose.

DSRB S
Sheave block for rope guidance,
equipped with ball bearings

Technical data DSRB S

| Model | Art.-No. | Classification FEM/ISO | Pulling force | Pulling force | Rope diameter mm |
|---------------|----------|---------------------------|-------------------------------|--------------------------------|---------------------|
| | | | in kg at deflection 90° | in kg at deflection 180° | |
| DSRB S 90/4 | 33447103 | 2m/M5 | 700 | 500 | 4 |
| DSRB S 90/6 | 33447413 | 1Dm/M1 | 700 | 500 | 4 |
| DSRB S 145/5 | 33447104 | 4m/M6 | 1100 | 800 | 5 |
| DSRB S 145/6 | 33447105 | 2m/M5 | 1100 | 800 | 6 |
| DSRB S 145/7 | 33447106 | 1 Am/M4 | 1100 | 800 | 6 |
| DSRB S 185/8 | 33447107 | 2m/M5 | 2300 | 1630 | 8 |
| DSRB S 185/9 | 33447108 | 1 Am/M4 | 2300 | 1630 | 9 |
| DSRB S 270/12 | 33447111 | 2m/M5 | 2500 | 1800 | 12 |

All sheaves are available as an individual component on request.



Dimensions DSRB S

| Model | DSRB S 90/4 | DSRB S 90/6 | DSRB S 145/5 | DSRB S 145/6 | DSRB S 145/7 | DSRB S 185/8 | DSRB S 185/9 | DSRB S 270/12 |
|------------|-------------|-------------|--------------|--------------|--------------|--------------|--------------|---------------|
| Art.-No. | 33447103 | 33447413 | 33447104 | 33447105 | 33447106 | 33447107 | 33447108 | 33447111 |
| B, mm | 85 | 85 | 125 | 125 | 125 | 138 | 138 | 191 |
| C, mm | 90 | 90 | 160 | 160 | 160 | 195 | 195 | 290 |
| Ø D, mm | 90 | 90 | 145 | 145 | 145 | 185 | 185 | 270 |
| Ø D1, mm | 20 | 20 | 25 | 25 | 25 | 30 | 30 | 40 |
| Ø Dm, mm | 80 | 78 | 125 | 125 | 126 | 160 | 162 | 246 |
| E, mm | 62 | 62 | 88 | 88 | 88 | 106 | 106 | 138 |
| H, mm | 134 | 134 | 224 | 224 | 224 | 273 | 273 | 407 |
| K, mm | 65 | 65 | 110 | 110 | 110 | 135 | 135 | 202 |
| L, mm | 120 | 120 | 200 | 200 | 200 | 245 | 245 | 360 |
| Ø M/M1, mm | 9/9 | 9/9 | 11.5/13 | 11.5/13 | 11.5/13 | 13.5/15 | 13.5/15 | 18/20 |
| S, mm | 4 | 4 | 6 | 6 | 6 | 8 | 8 | 10 |

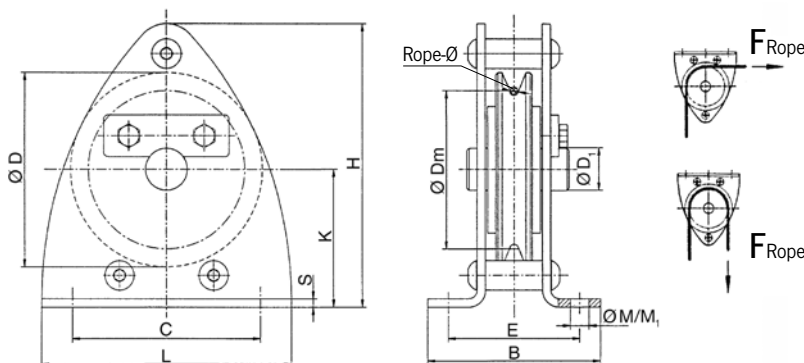

Functional principle of cranks

Safety crank (Siku) and ratchet crank (Raku)

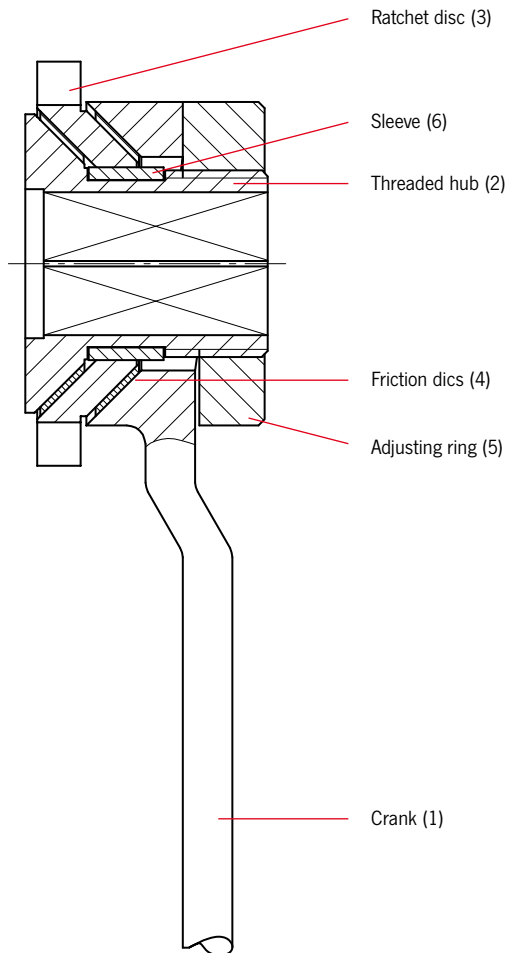

Lifting

By turning the crank (1) clockwise, all brake parts like friction discs (4), ratchet disc (3) and threaded hub (2) locked to a complete system. All components rotate in the same direction and the ratchet pawls (not shown here) engage alternately in the teeth on the ratchet disc. The load is hold securely in any position.

Lowering

If the crank will be rotate counterclockwise, the brake opens minimally. The ratchet disc is fixed by the ratchet pawls and does not rotate.

The load, which is either on the head or the claw, presses the housing down and causes the brake to close again. This process is repeated continuously when the load is released until the winch is unloaded.

With the safety crank (Siku), it is necessary to turn the crank through 360° when lifting and lowering.

The ratchet crank (Raku) works like a hand lever on a manual hoist. By switching the switch lever to lifting or lowering, this crank can be used like a ratchet. This is particularly useful in limited space. Furthermore, this type of crank can also be operated through 360°, as the same braking system as the Siku.

Crank overview (note: please pay attention to the corresponding capacity)

| Model | Siku | Raku | Sifeku | Siku (short) | Raku (short) | Siku (elbowed) | Crank with/without folding handle | Safety spring-lock with plug crank |
|---------|------|------|--------|--------------|--------------|----------------|-----------------------------------|------------------------------------|
| SJ/RSJ | | • | | | | | | |
| STW-F | • | • | | | | | | |
| STW-V | • | • | | | | | | |
| STW-FvB | | | | • | • | | | |
| ZWW-L | | | | | | | • | |
| ZWW | • | | • | | | | | |
| HB-W | | | | | | • | | |
| KHB | • | | | | | | | |
| SCH-W | • | | • | | | | | • |

Siku

Safety crank, zinc-plated

- With one-sided braking effect.
- The load is held safely at every height.
- With folding handle.

Crank for rack and pinion jacks

STW-F, STW-V, STW-FvB, ZWW, KHB and SCH-W

| Model | Art.-No. | Capacity kg | Length of crank mm | Square drive mm |
|-----------------------|----------|-------------|--------------------|-----------------|
| Siku 15, zinc-plated | 40006026 | 1500 | 250 | 14 |
| Siku 30, zinc-plated | 40006026 | 3000 | 250 | 14 |
| Siku 50, zinc-plated | 40006026 | 5000 | 250 | 14 |
| Siku 100, zinc-plated | 40006171 | 10000 | 300 | 17 |
| Siku 15, painted | 40005461 | 1500 | 250 | 17 |
| Siku 30, painted | 40005461 | 3000 | 250 | 17 |
| Siku 50, painted | 40005461 | 5000 | 250 | 17 |



Crank for steel jacks

STW-FvB

| Model | Art.-No. | Capacity kg | Length of crank mm | Square drive mm |
|------------------|-----------|-------------|--------------------|-----------------|
| Siku 15, painted | N00190073 | 1500 | 200 | 14 |
| Raku 15, painted | 192034961 | 1500 | 200 | 14 |



Crank for lifting jack

HB-W

| Model | Art.-No. | Capacity kg | Length of crank mm | Square drive mm |
|----------------------|-----------|-------------|--------------------|-----------------|
| Siku 15, zinc-plated | N00190074 | 1500 | 250 | 14 |



INFO

For ordering the crank of the models STW-F, STW-V, STW-FvB, KHB and SCH-W it takes note to specify the manufacture year, capacity and the dimension of the square!

Siku & Raku Safety ratchet crank

- Lifting or lowering movement adjustable by turning a lever.
- The load is held safely at every height.
- With folding handle.



Crank for steel jacks SJ and RSJ

| Model | Art.-No. | Capacity kg | Length of crank mm | Square drive mm |
|-------------------|-----------|-------------|--------------------|-----------------|
| Siku 15, painted | N00190008 | 1500 | 230 | 12 |
| Siku 30, painted | N00190022 | 3000 | 250 | 14 |
| Siku 50, painted | N00190053 | 5000 | 275 | 14 |
| Siku 100, painted | N00190044 | 10000 | 300 | 17 |
| Raku 15, painted | 192037671 | 1500 | 230 | 12 |
| Raku 30, painted | 192037672 | 3000 | 250 | 14 |
| Raku 50, painted | 192037672 | 5000 | 250 | 14 |
| Raku 100, painted | 192037673 | 10000 | 300 | 17 |



Crank for steel jacks STW-F, STW-V and STW-FvB

| Model | Art.-No. | Capacity kg | Length of crank mm | Square drive mm |
|-----------------------|----------|-------------|--------------------|-----------------|
| Raku 15, zinc-plated | 40010237 | 1500 | 250 | 14 |
| Raku 30, zinc-plated | 40010237 | 3000 | 250 | 14 |
| Raku 50, zinc-plated | 40010237 | 5000 | 250 | 14 |
| Raku 100, zinc-plated | 40008213 | 10000 | 300 | 17 |
| Raku 15, painted | 40004840 | 1500 | 250 | 17 |
| Raku 30, painted | 40004840 | 3000 | 250 | 17 |
| Raku 50, painted | 40004840 | 5000 | 250 | 17 |



Ratchet pawl kit for Siku and Raku

P13 for 1.5t, 3.0t and 5.0t

Art.-No. 40003808

P14 for 10.0t

Art.-No. N040004648

Safety spring crank (Sifeku) or safety spring lock with crank handle

Lifting and lowering

To generate the pre-tension, the spring (3) is manufactured with an oversize in relation to the brake ring (4) and installed.

The pre-tensioning torque which is generated corresponds at the same time to the no-load torque.

Turning the crank (1) clockwise the load will be lifted or supported.

Thereby the spring preload between spring (3) and brake ring (4) is increased.

In this case, the load is hold in any position up to the maximum braking torque and pressed against the brake ring.

The lowering process works in the same way, except that the crank (1) is turned anticlockwise.

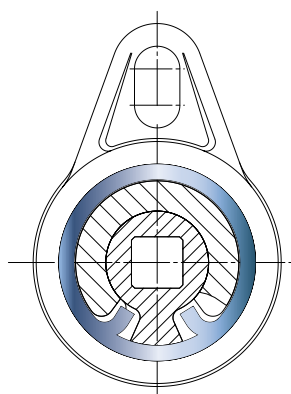
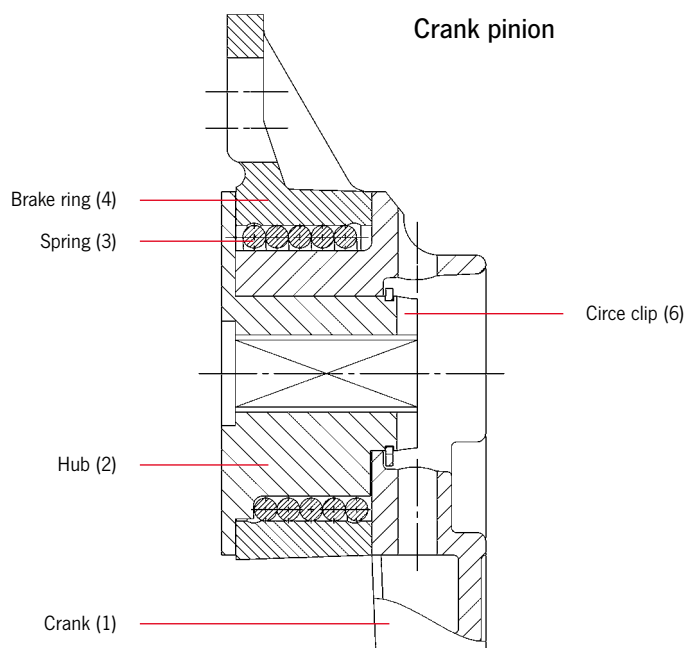

Brake new

the spring has sufficient movement in both directions

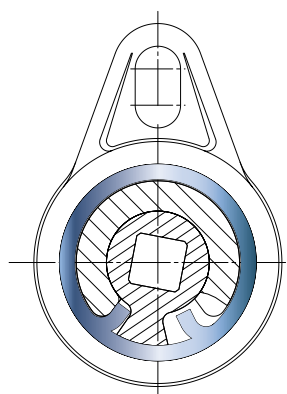

Brake, with braking torque

applied during lifting

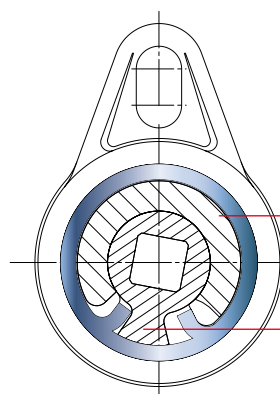

Brake during lowering

Spring (3) is released by the crank arm driver (a) and closed again by the load carrier (b)



Sifeku
Spring loaded safety crank

- Without pawl
- Silent
- Recoil proof
- Maintenance-free
- Enclosed housing
- Weather and temperature resistant.
- Braking effect at both ends.
- The load is held safely at every height, in the pushing and pulling direction.
- Approved by the TÜV as an independent crank.
- With folding handle.

Crank for rack and pinion jacks
STW-F, STW-V, STW-FvB, ZWW, GmZ, KHB and SCH-W

| Model | Art.-No. | Capacity kg | Length of crank mm | Square drive mm |
|--------------------|----------|-------------|--------------------|-----------------|
| Sifeku 15, painted | 40004581 | 1500 | 250 | 14 |
| Sifeku 30, painted | 40004581 | 3000 | 250 | 14 |
| Sifeku 50, painted | 40004581 | 5000 | 250 | 14 |
| Sifeku 15, painted | 40003433 | 1500 | 250 | 17 |
| Sifeku 30, painted | 40003433 | 3000 | 250 | 17 |
| Sifeku 50, painted | 40003433 | 5000 | 250 | 17 |



Sifespe
Safety spring-lock with plug crank

- Plug crank removable
- No ratchet pawls in use
- Silent
- Maintenance-free
- Closed housing
- Weather and temperature resistant
- Braking effect at both ends
- The load is held safely at every height
- Handle not folding

Safety spring-lock with plug crank
for rack and pinion jacks ZWW, GmZ and SCH-W

| Model | Art.-No. | Capacity kg | Length of crank mm | Square drive mm |
|------------------|----------|-------------|--------------------|-----------------|
| Sifespe, painted | 40051858 | 1500 - 5000 | 250 | 14/17 |
| Plug crank Alu | 39102698 | 1500 - 5000 | 250 | 17 |

Worm gear (ZWW-L)

The self-locking worm gear ensures that the load is held securely in any position.

Rack
Housing
Gear
Crank pinion
Worm gear



Crank for rack and pinion jacks ZWW-L

| Model | Art-No. | Capacity kg | Length of crank mm | Square drive mm |
|----------------|-----------|-------------|--------------------|-----------------|
| Standard crank | N00190083 | 250 | 200 | 12 |
| Standard crank | N00190082 | 500 | 250 | 12 |
| Standard crank | N00190083 | 1000 | 200 | 12 |

Crank with folding handle for rack and pinion jacks ZWW-L (only optional)

| Model | Art-No. | Capacity kg | Length of crank mm | Square drive mm |
|-----------------------|-----------|-------------|--------------------|-----------------|
| - with folding handle | N00190063 | 250 | 200 | 12 |
| - with folding handle | N00190064 | 500 | 250 | 12 |
| - with folding handle | N00190063 | 1000 | 200 | 12 |

Option:
Crank with folding handle for rack and pinion jacks ZWW-L





SJ Steel jack acc. to DIN 7355

Capacity 1500 - 10000 kg

Mechanical steel jacks can basically be used to lift almost all kinds of loads in maintenance and repair, ship building, construction as well as agriculture.

Steel winches are used for supporting, placing lifted loads underneath and for assembly work.

The Raku as a standard crank enables working in limited spaces, as it can be used like a ratchet in the direction of lifting and lowering. Alternatively, you can work with the crank 360°.

The field of application includes maintenance and repair, shipbuilding, the construction sector and agriculture.

Features

- The precisely machined gear box with optimal gear ratio ensures a minimum of effort and smooth operation.
- The load is supported either on the claw or the head of the steel jack.
- By turning the operating lever the jack moves smoothly and conveniently up and down along the rack.
- The load is held securely in any position. Inside the load brake the axial brake pressure is generated by the load itself, thus, it is proportional to the size of the load.
- No reduction of capacity on the claw.

Technical data SJ Raku

| Model | Art.-No. Raku | Capacity kg | Height A mm | Lift ¹ mm | Hand effort at WLL daN | Weight kg |
|--------|------------------|----------------|-------------------|-------------------------|------------------------------|--------------|
| SJ 15 | N01900005 | 1500 | 725 | 360 | 28 | 17 |
| SJ 30 | N01900002 | 3000 | 735 | 360 | 28 | 20 |
| SJ 50 | N01900003 | 5000 | 730 | 350 | 28 | 27 |
| SJ 100 | N01900006 | 10000 | 800 | 410 | 56 | 43 |

¹Height of lift = Height + Lift

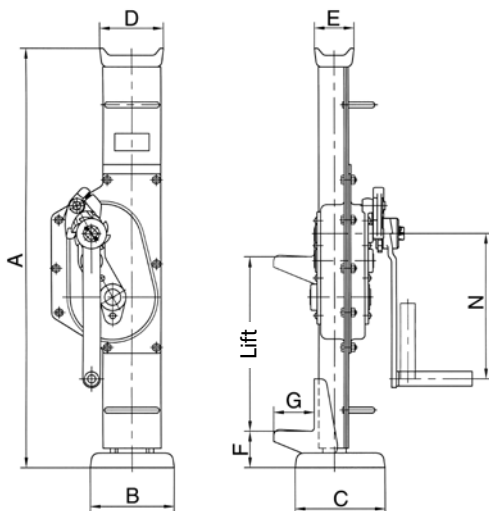

Dimensions SJ

| Model | SJ 15 | SJ 30 | SJ 50 | SJ 100 |
|-------|-------|-------|-------|--------|
| A, mm | 725 | 735 | 730 | 800 |
| B, mm | 164 | 200 | 190 | 252 |
| C, mm | 140 | 140 | 170 | 170 |
| D, mm | 76 | 83 | 108 | 124 |
| E, mm | 38 | 38 | 52 | 65 |
| F, mm | 70 | 70 | 80 | 85 |
| G, mm | 60 | 65 | 71 | 86 |
| N, mm | 225 | 249 | 275 | 300 |

STW-F Steel jacks acc. to DIN 7355 with fixed lifting claw

Capacity 1500 - 10000 kg

Steel jacks are traditional hoisting equipment for universal application in the forest and agricultural sector, in the industrial sector for assembly activities and many other fields of application.

Features

- The robust steel design and a toothed rack of solid material increase the service life of the jack.
- Low wear owing to hardened gearing parts and precisely machined teething.
- The precisely machined gears with a high degree of efficiency guarantees low crank forces.
- The load is supported either on the claw or the head of the steel jack.
- Robust base plate for a high level of stability.
- No reduction of capacity on the claw.



Model STW-F
with fixed lifting claw
and Sifeku

Technical data STW-F Siku

| Model | Art.-No. Siku | Capacity kg | Height A mm | Lift ¹ mm | Hand effort at WLL daN | Weight kg |
|-----------|------------------|----------------|-------------------|-------------------------|------------------------------|--------------|
| STW-F 15 | 40021975 | 1500 | 720 | 350 | 28 | 12 |
| STW-F 30 | 40021984 | 3000 | 720 | 350 | 28 | 21 |
| STW-F 50 | 40051705 | 5000 | 720 | 300 | 28 | 26 |
| STW-F 100 | 40051707 | 10000 | 792 | 300 | 40 | 42 |

¹Height of lift = Height + Lift

Technical data STW-F Raku

| Model | Art.-No. Raku | Capacity kg | Height A mm | Lift ¹ mm | Hand effort at WLL daN | Weight kg |
|-----------|------------------|----------------|-------------------|-------------------------|------------------------------|--------------|
| STW-F 15 | 40022008 | 1500 | 720 | 350 | 28 | 12 |
| STW-F 30 | 40022013 | 3000 | 720 | 350 | 28 | 21 |
| STW-F 50 | 40022019 | 5000 | 720 | 300 | 28 | 26 |
| STW-F 100 | 40051708 | 10000 | 792 | 300 | 28 | 42 |

¹Height of lift = Height + Lift

Dimensions STW-F

| Model | STW-F 15 | STW-F 30 | STW-F 50 | STW-F 100 |
|-------|----------|----------|----------|-----------|
| A, mm | 720 | 720 | 720 | 792 |
| B, mm | 130 | 130 | 145 | 145 |
| C, mm | 140 | 140 | 155 | 155 |
| D, mm | 90 | 90 | 110 | 125 |
| E, mm | 50 | 50 | 68 | 80 |
| F, mm | 60 | 61 | 62 | 85 |
| G, mm | 60 | 65 | 70 | 85 |
| N, mm | 250 | 250 | 250 | 300 |

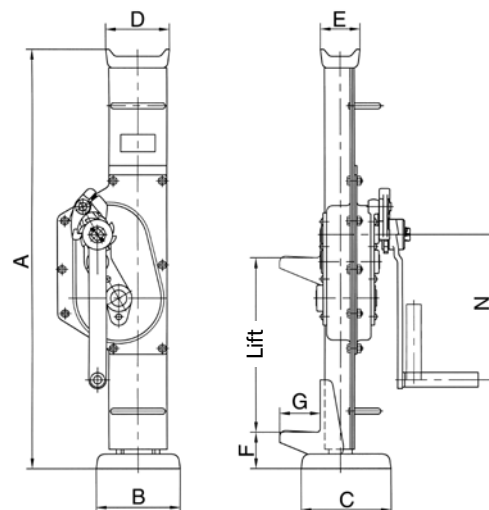

INFO

STW-F Sifeku on request.

STW-V
1.5t/3.0t/5.0t



STW-V 10.0t

STW-V Steel jacks acc. to DIN 7355 with adjustable lifting claw

Capacity 1500 - 10000 kg

The design of the steel jack allows for loads to be picked up and lowered from different heights over the entire length of the steel jack.

The adjustable claw is simply set to the appropriate application height in the load bar for this purpose.

Features

- The claw can be moved to any position on the adjusting rail.
- The load is supported either on the claw or the head of the steel jack.
- Robust base plate for a high level of stability.
- No reduction of capacity on the claw.

Technical data STW-V Siku

| Model | Art.-No. Siku | Capacity kg | Height A mm | Lift ¹ mm | Hand effort at WLL daN | Weight kg |
|-----------|------------------|----------------|-------------------|-------------------------|------------------------------|--------------|
| STW-V 15 | N01905000 | 1500 | 725 | 350 | 28 | 17 |
| STW-V 30 | N01905001 | 3000 | 725 | 350 | 28 | 23 |
| STW-V 50 | N01905002 | 5000 | 725 | 300 | 28 | 29 |
| STW-V 100 | N01905003 | 10000 | 792 | 300 | 40 | 46 |

¹Height of lift = Height + Lift

Technical data STW-V Raku

| Model | Art.-No. Raku | Capacity kg | Height A mm | Lift ¹ mm | Hand effort at WLL daN | Weight kg |
|-----------|------------------|----------------|-------------------|-------------------------|------------------------------|--------------|
| STW-V 15 | N01905004 | 1500 | 725 | 350 | 28 | 17 |
| STW-V 30 | N01905005 | 3000 | 725 | 350 | 28 | 23 |
| STW-V 50 | N01905006 | 5000 | 725 | 300 | 28 | 29 |
| STW-V 100 | N01905007 | 10000 | 792 | 300 | 40 | 46 |

¹Height of lift = Height + Lift

INFO

STW-V Sifeku on request

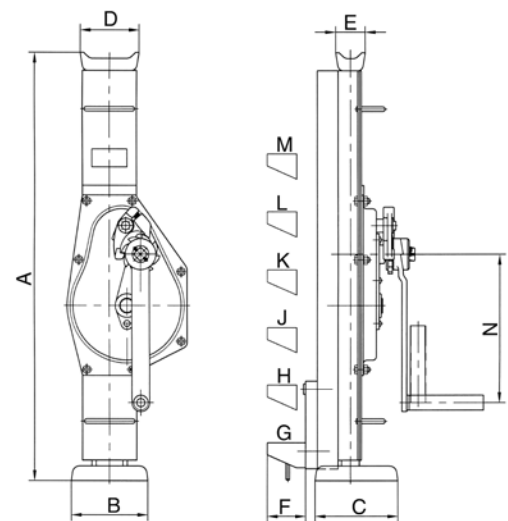

Dimensions STW-V

| Model | STW-V 15 | STW-V 30 | STW-V 50 | STW-V 100 |
|-------|--|----------|----------|-----------|
| A, mm | 725 | 725 | 725 | 800 |
| B, mm | 130 | 130 | 140 | 140 |
| C, mm | 140 | 140 | 160 | 160 |
| D, mm | 90 | 100 | 110 | 140 |
| E, mm | 50 | 50 | 68 | 76 |
| F, mm | 70 | 70 | 70 | 70 |
| G, mm | 80 | 80 | 80 | 85 |
| H, mm | | | | 191 |
| J, mm | Claw freely adjustable on load bar (55 mm steps) | | | 297 |
| K, mm | | | | 403 |
| L, mm | | | | 509 |
| M, mm | | | | 615 |
| N, mm | 250 | 250 | 250 | 300 |

STW-FvB Steel jacks acc. to DIN 7355 with fixed lifting claw shortened design

Capacity 1500 kg

Wherever low headroom dimensions are required, the steel jack of shortened design is used.

Features

- The robust steel design and a toothed rack of solid material increase the service life of the jack.
- Low wear owing to hardened gearing parts and precisely machined teething.
- The precisely machined gears with a high degree of efficiency guarantees low crank forces.
- The load is supported either on the claw or the head of the steel jack.
- Robust base plate for a high level of stability.
- No reduction of capacity on the claw.



Technical data STW-FvB Siku

| Model | Art.-No. Siku | Capacity kg | Height A mm | Lift ¹ mm | Hand effort at WLL daN | Weight kg |
|------------|-------------------------|----------------|-------------------|-------------------------|------------------------------|--------------|
| STW-FvB 15 | 30014000 | 1500 | 600 | 300 | 28 | 11 |

¹Height of lift = Height + Lift

Technical data STW-FvB Raku

| Model | Art.-No. Raku | Capacity kg | Height A mm | Lift ¹ mm | Hand effort at WLL daN | Weight kg |
|------------|-------------------------|----------------|-------------------|-------------------------|------------------------------|--------------|
| STW-FvB 15 | 30014002 | 1500 | 600 | 300 | 28 | 11 |

¹Height of lift = Height + Lift

Dimensions STW-FvB

| Model | STW-FvB 15 |
|-------|------------|
| A, mm | 600 |
| B, mm | 130 |
| C, mm | 140 |
| D, mm | 90 |
| E, mm | 50 |
| F, mm | 60 |
| G, mm | 60 |
| N, mm | 200 |

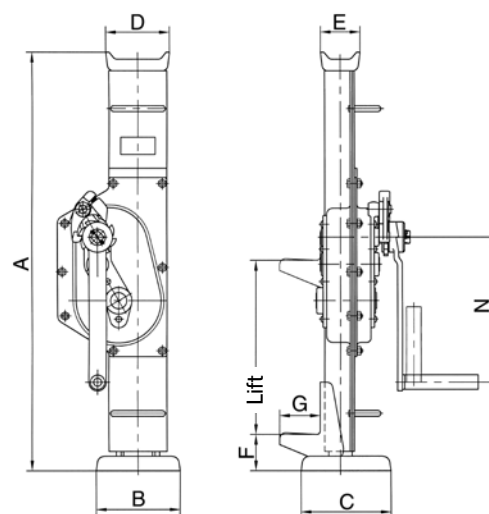

INFO

STW-FvB Sifeku on request



INFO

On page 185 you will find also rail grab.

RSJ

Rail jacks acc. to DIN 7355

Capacity 5000 kg

Track rails can be quickly and safely lifted by means of this jack, also under unfavourable conditions.

The shoe-type foot with a wider support surface makes it possible to apply the jack between the sleepers and the tracks.

Features

- The precisely machined gear box with optimal gear ratio ensures a minimum of effort and smooth operation.
- The load is supported either on the claw or the head of the steel jack.
- By turning the operating lever the jack moves smoothly and conveniently up and down along the rack.
- The self-locking, anti-kickback operating lever reduces the risk of injuries. The handle can be tilted for use in confined spaces.
- The load is held securely in any position. Inside the load brake the axial brake pressure is generated by the load itself, thus, it is proportional to the size of the load.
- No reduction of capacity on the claw.

Technical data RSJ Raku

| Model | Art.-No. Raku | Capacity kg | Height A mm | Lift ¹ mm | Hand effort at WLL daN | Weight kg |
|--------|------------------|----------------|-------------------|-------------------------|------------------------------|--------------|
| RSJ 50 | N01900008 | 5000 | 740 | 360 | 28 | 29 |

¹Height of lift = Height + Lift

Dimensions RSJ

| Model | RSJ 50 |
|-------|--------|
| A, mm | 740 |
| B, mm | 200 |
| C, mm | 250 |
| D, mm | 108 |
| E, mm | 52 |
| F, mm | 90 |
| G, mm | 71 |
| N, mm | 275 |

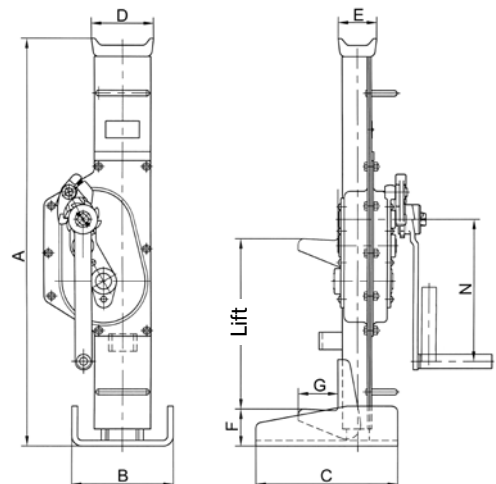

Yaletaurus Ratchet jack

Capacity 10000 kg

Mechanical ratchet jacks with lifting claw are designed for operation in confined areas where space below the load is restricted, thus preventing the use of traditional lifting equipment. The Yaletaurus is the ideal unit for lifting, positioning or transportation of machines resp. heavy objects as well as for repair and assembly jobs in cramped areas and under toughest conditions.

In spite of its capacity of 10000 kg the Yaletaurus has a weight of just 30 kg and the integrated carrying handle makes it a portable, versatile tool.

With a hand force of 45 kg on the detachable hand lever, the Yaletaurus will lift, press, push or lower a load of 10000 kg in any direction. A standard crank wheel will bring the jack quickly to the required position.

Features

- Automatic screw-and-disc type load brake.
The axial brake pressure is generated by the load itself and is, therefore, proportional to the size of the load.
The load is held secure in any position.
- Single part housing made from spheroidal cast iron with integrated lifting claw.
- The screw-and-disc type load brake originates from the Yale PUL-LIFT® (spare parts are easily available).
- Low lever pull and long life endurance due to optimum gearing and high quality materials.



Technical data Yaletaurus

| Model | Art.-No. | Capacity on the head kg | Capacity on the claw kg | Height A mm | Lift ¹ mm | Hand effort at WLL daN | Weight kg |
|------------|----------|-------------------------|-------------------------|-------------|----------------------|------------------------|-----------|
| Yaletaurus | N0130003 | 10000 | 7000 | 505 | 295 | 45 | 30 |

¹Height of lift = Height + Lift

Dimensions Yaletaurus

| Model | Yaletaurus |
|-------|------------|
| A, mm | 505 |
| B, mm | 170 |
| C, mm | 125 |
| D, mm | 95 |
| E, mm | 65 |
| F, mm | 75 |
| G, mm | 75 |
| H, mm | 238 |
| J, mm | 217 |
| N, mm | 647 |

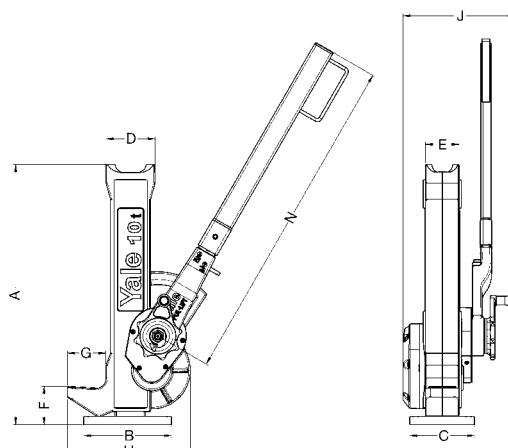



ZWW-L
Capacity 300 kg u. 600 kg



ZWW-L
Capacity 1200 kg



ZWW
Capacity 1500 kg



ZWW
Capacity 10000 kg

ZWW-L and ZWW Wall-mounted rack and pinion jacks

Capacity 300 - 10000 kg

Wall-mounted rack and pinion jacks are used for lifting, lowering, pulling and pushing of loads.

Features

- Robust steel design with precisely machined worm and spur gears for smooth and easy manual operation.
- Solid steel rack with additional bore hole for fastening of the load.
- Low wear owing to hardened gearing parts and precisely machined teething.
- Up to 1200 kg lifting load for pushing or pulling loads are equal.
- At standard tensile load from 1500 - 10000 kg. Compressive load possible on request.
- Rigid wall mounting.

Options

- Improved corrosion protection owing to zinc-plating or special coating of rack (from capacity 1500 kg).
- Different rack length on request.
- Symmetrical toothing for model ZWW on request.
- Crank with folding handle for model ZWW-L.

INFO

ZWW-L with capacities of 600 and 1000 kg are also available in explosion-proof design.



We are pleased to send you our new Atex catalogue in PDF format.

Technical data ZWW-L

| Model | Art.-No. | Tensile or pressure load kg | Rack length mm | Lift mm | Lift per crank rotation mm | Hand effort at WLL daN | Weight kg |
|-----------------|-----------|-----------------------------|----------------|---------|----------------------------|------------------------|-----------|
| ZWW-L 300/400 | NO1905011 | 300 | 600 | 400 | 11 | 10 | 5.4 |
| ZWW-L 600/400 | NO1905012 | 600 | 600 | 400 | 11 | 15 | 6.0 |
| ZWW-L 300/600 | NO1905013 | 300 | 800 | 600 | 11 | 10 | 5.9 |
| ZWW-L 600/600 | NO1905014 | 600 | 800 | 600 | 11 | 15 | 6.5 |
| ZWW-L 1200/600 | NO1905015 | 1200 | 800 | 600 | 3.6 | 14 | 9.5 |
| ZWW-L 300/800 | NO1905016 | 300 | 1000 | 800 | 11 | 10 | 6.4 |
| ZWW-L 600/800 | NO1905017 | 600 | 1000 | 800 | 11 | 15 | 7.0 |
| ZWW-L 1200/800 | NO1905018 | 1200 | 1000 | 800 | 3.6 | 14 | 10.6 |
| ZWW-L 600/1000 | NO1905020 | 600 | 1200 | 1000 | 11 | 15 | 7.5 |
| ZWW-L 1200/1000 | NO1905021 | 1200 | 1200 | 1000 | 3.6 | 14 | 11.7 |
| ZWW-L 600/1200 | NO1905023 | 600 | 1400 | 1200 | 11 | 10 | 6.0 |

Technical data ZWW with Sifeku

| Model | Art.-No. Sifeku | Tensile load kg | Rack length mm | Lift mm | Lift per crank rotation mm | Hand effort at WLL daN | Weight kg |
|--------------|--------------------|--------------------|-------------------|------------|----------------------------------|------------------------------|--------------|
| ZWW 1500/800 | 40055131 | 1500 | 1090 | 800 | 14 | 28 | 11 |
| ZWW 3000/565 | 40056138 | 3000 | 975 | 565 | 9 | 28 | 19 |
| ZWW 5000/700 | 40057134 | 5000 | 1170 | 700 | 4.5 | 28 | 28 |

Technical data ZWW with Siku

| Model | Art.-No. Siku | Tensile load kg | Rack length mm | Lift mm | Lift per crank rotation mm | Hand effort at WLL daN | Weight kg |
|---------------|------------------|--------------------|-------------------|------------|----------------------------------|------------------------------|--------------|
| ZWW 10000/700 | 40058009 | 10000 | 1240 | 700 | 3.2 | 40 | 55 |

Dimensions ZWW and ZWW-L

| Model | ZWW-L 300 | ZWW-L 600 | ZWW-L 1200 | ZWW 1500 | ZWW 3000 | ZWW 5000 | ZWW 10000 |
|---------|-----------|-----------|------------|----------|----------|----------|-----------|
| A, mm | 20 | 20 | 25 | 35 | 45 | 50 | 60 |
| B, mm | 20 | 25 | 35 | 25 | 30 | 40 | 50 |
| C, mm | - | - | - | 215 | 280 | 330 | 380 |
| Ø D, mm | 11 | 13 | 16,5 | 21 | 21 | 21 | 30 |
| E, mm | 16 | 20 | 20 | 20 | 25 | 25 | 30 |
| F, mm | 130 | 130 | 127 | 135 | 165 | 140 | 160 |
| G, mm | 119 | 119 | 98 | 151 | 212 | 219 | 269 |
| H, mm | 200 | 200 | 180 | 310 | 395 | 400 | 480 |
| I, mm | - | - | 35 | 168 | 179 | 197 | 200 |
| J, mm | 38 | 35 | 30 | 26 | 31 | 37 | 40 |
| K, mm | - | - | - | 100 | 120 | 120 | 140 |
| L, mm | 60 | 60 | 140 | 130 | 160 | 160 | 180 |
| M, mm | 170 | 170 | 140 | 260 | 305 | 320 | 410 |
| Ø N, mm | 11 | 11 | 13 | 13 | 15 | 17 | 21 |
| O, mm | - | - | 100 | 110 | 120 | 105 | 125 |
| P, mm | - | - | - | 40 | 50 | 50 | 60 |
| Q, mm | 10 | 10 | - | 8 | 10 | 10 | 10 |
| R, mm | 200 | 250 | 200 | 250 | 250 | 250 | 300 |
| S, mm | 110 | 110 | 110 | 130 | 130 | 130 | 250 |
| T, mm | - | - | - | 42 | 86 | 109 | 150 |
| U, mm | - | - | - | 43 | 53 | 70 | 88 |
| X, mm | - | - | - | 20 | 25 | 45 | 30 |
| Ø Z, mm | - | - | - | - | - | - | - |

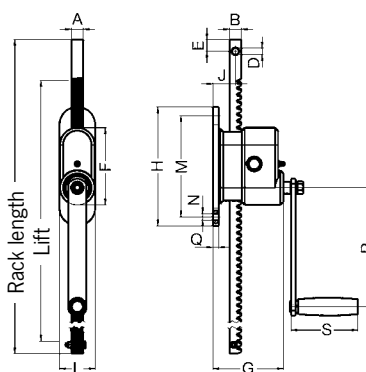

ZWW-L, Capacity 300 - 600 kg

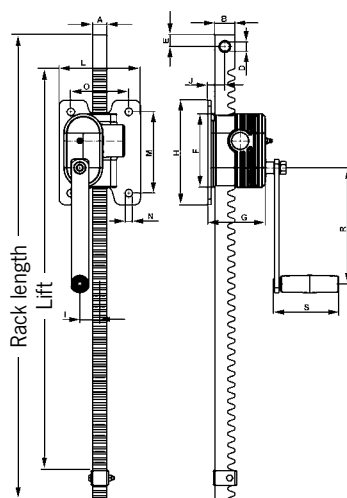

ZWW-L, Capacity 1200 kg

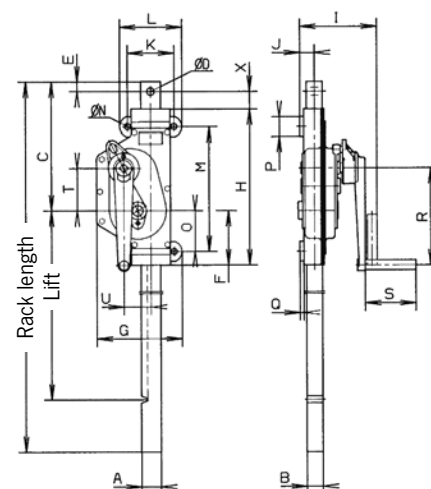

ZWW, Capacity 1500 - 10000 kg



On systems with several racks in line at 90° to the crank axis

- Self-locking action **only gear unit with crank**
- Crank force = 15 kg, at a **maximum** total load of 1000 kg
- Connection to 1" tube (DIN 2440) on building side
- This combination is also possible for model ZWW-L 250 and model ZWW-L 500.

ZWW-L combinations

Capacity 1000 kg

Where it is important to lift as evenly as possible (leveling), wall-mounted rack and pinion wall jacks can also be coupled, whereby the direction - depending on the model - is irrelevant.

The wall mounted rack and pinion jacks can be combine about 3/4" and/or 1" pipes (DIN 2440). When connecting pipes over a length of 2 m, we recommend the pipes to stabilize so that it does not droop in the middle.

We like to advise you in this case.

On systems with several racks in line to the crank axis

- Self-locking action in **every gear unit**
- Crank force = 15 kg with a total load of 1000 kg
- Connection to 3/4" tube (DIN 2440) on building side



On systems with several racks across a surface area

- Self-locking action in **all gear units in the crank axis**
- Crank force = 15 kg with a total load of 1000 kg
- Connection 3/4" and 1" tube (DIN 2440) on building side

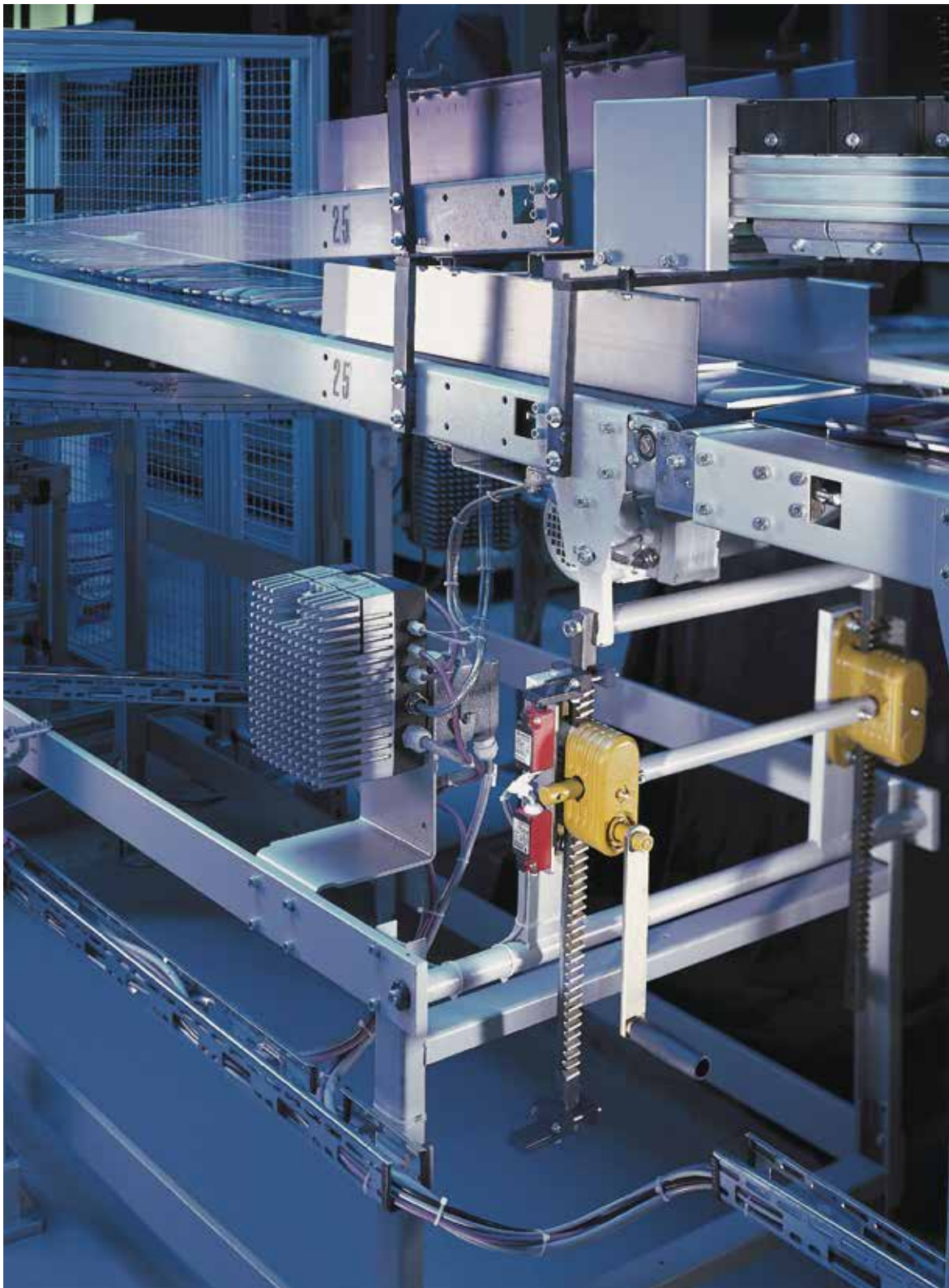



HB-W Lifting jack

Capacity 1500 kg

The stable lifting jack with integrated 1.5t steel jack for supporting tube and bar material.

Features

- Load will be fixed in each position safely by a load brake system.
- Large base plate for a high level of stability.
- Wheels for easy transport.

Option

- The attachable support roller facilitates the sliding of heavy loads.

Technical data HB-W

| Model | Art.-No. Siku | Capacity kg | Height mm | Lift ¹ mm | Hand effort at WLL daN | Lift per crank rotation mm | Weight kg |
|-----------|------------------|----------------|--------------|-------------------------|------------------------------|----------------------------------|--------------|
| HB-W 1500 | N01900014 | 1500 | 650 | 350 | 28 | 15 | 40 |

¹Height of lift = Height + Lift

Technical data supporting roller HB-A

| Model | Art.-No. | Capacity kg | Height with supporting roller in mm | Weight kg |
|-------------------|----------|----------------|---|--------------|
| Supporting roller | 30060011 | 1500 | 705 | 5 |

Dimensions HB-W

| Model | HB-W 1500 |
|-----------------------|-----------|
| A, mm | 300 |
| B, mm | 500 |
| C _{on} , mm | 650 |
| D _{off} , mm | 1000 |
| E, mm | 100 |
| F, mm | 320 |
| G, mm | 300 |
| H, mm | 385 |

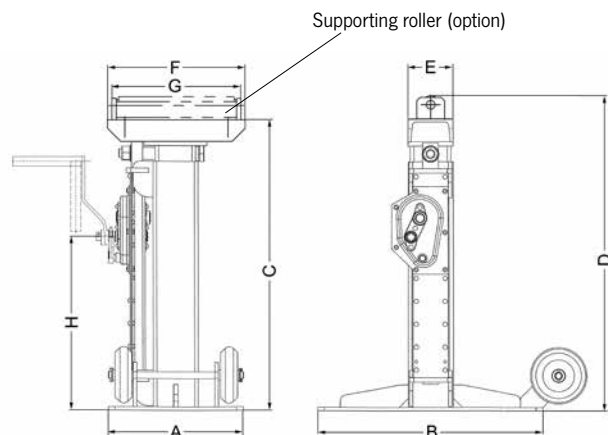

KHB

Truck body lifting jack

Capacity 5000 and 8000 kg

Truck body lifting jacks are used for supporting vehicle bridges, swap bodies and trailers; they are also used in vehicle construction and freight forwarding applications.

Features

- High-quality, torsionally stiff steel design with large base plate for a high level of stability.
- Hardened gearing parts and precisely machined teeth-ing for improved handling and low wear.
- The load can either be supported on the head or on the adjustable claw.



KHB 5
Capacity 5000 kg



KHB 8
Capacity 8000 kg

Technical data KHB Siku

| Model | Art.-No. Siku | Capacity kg | Height mm | Lift ¹ mm | Hand effort at WLL daN | Dim. B mm | Dim. C mm | Dim. D mm | Dim. E mm | Dim. F mm | Dim. O/P mm | Weight kg |
|--------------|------------------|----------------|--------------|-------------------------|------------------------------|-----------------|-----------------|-----------------|-----------------|-----------------|-------------------|--------------|
| KHB 5000/500 | 30077011 | 5000 | 1100 | 500 | 18 | 540 | 500 | 80 | 140 | 250 | 70/70 | 80 |
| KHB 8000/500 | 30080012 | 8000 | 1100 | 500 | 26 | 540 | 500 | 100 | 170 | 300 | 150/180 | 111 |

¹ Height of lift = Height + Lift

Step height of adjustable lifting claw

| Model | KHB 5000 | KHB 8000 |
|--------------|----------|----------|
| 1. step, mm | 175 | 290 |
| 2. step, mm | 230 | 396 |
| 3. step, mm | 285 | 502 |
| 4. step, mm | 340 | 608 |
| 5. step, mm | 395 | 714 |
| 6. step, mm | 450 | 820 |
| 7. step, mm | 505 | 926 |
| 8. step, mm | 560 | 1032 |
| 9. step, mm | 615 | - |
| 10. step, mm | 670 | - |
| 11. step, mm | 725 | - |
| 12. step, mm | 780 | - |
| 13. step, mm | 835 | - |
| 14. step, mm | 890 | - |

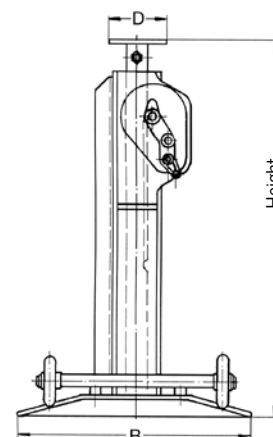
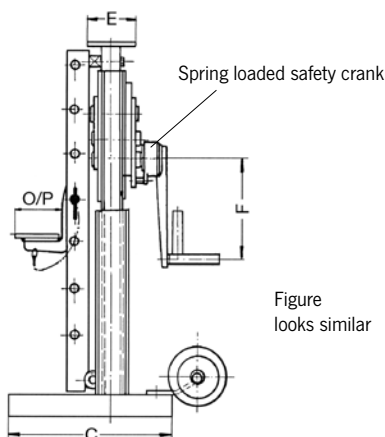



Model S 20



Model S 24

S 20 and S 24 Worm gear drive unit

The worm gear drives are suitable for a large variety of applications in construction for moving or turning loads, as gears for rope drums or chain sprockets or slewing drives.

Features

- Enclosed housing for the protection of parts inside.
- Enclosed and precisely machined gear for little effort and a long service life.

Technical data S 20 and S 24

| Model | Art.-No. | Ratio | Drive torque daNm | Required crank effort daN | Shaft length mm | Shaft diameter mm |
|-------|----------|-------|----------------------|---------------------------------|-----------------------|-------------------------|
| S 20 | 32626004 | 20:1 | 12 | 11 | 196 | 25 |
| S 24 | 32626020 | 24:1 | 36 | 22 | 200 | 36 |

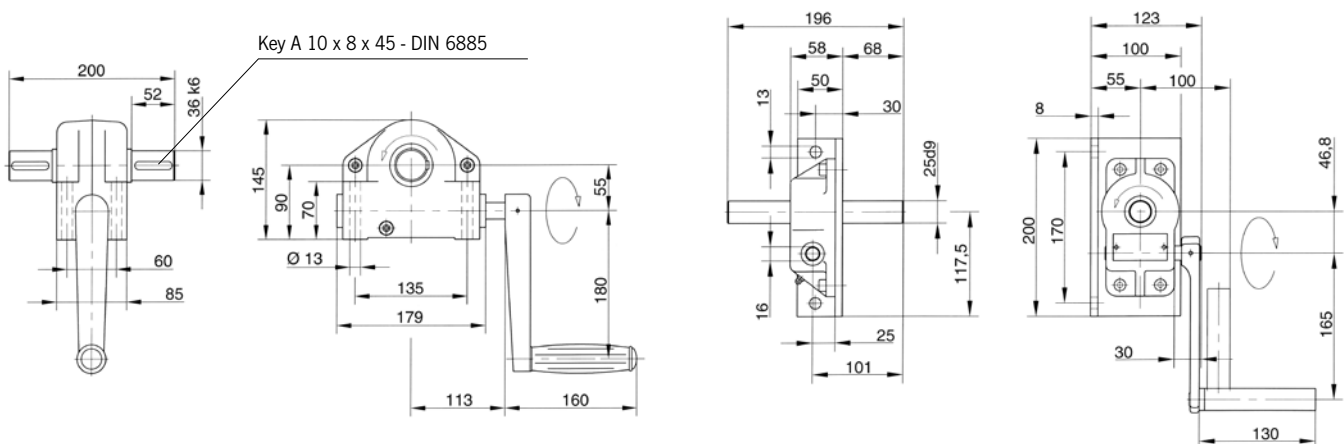

SCH-W Sluice gate jack

Capacity 1500 - 10000 kg

The reliable sluice gate jack for opening and closing gates in sluices.

Features

- The spring loaded safety crank permanently holds the sluice gate closed with pressure.
- Hardened gearing parts and precisely machined teething for improved handling and low wear.



Technical data SCH-W Sifeku

| Model | Art.-No. Sifeku | Tensile or pressure load ¹ kg | Rack length mm | Lift mm | Hand effort at WLL daN | Weight kg |
|----------|--------------------|---|-------------------|------------|---------------------------|--------------|
| SCH-W 15 | 40051714 | 1500 | 1200 | 800 | 28 | 18 |
| SCH-W 30 | 40051717 | 3000 | 1250 | 800 | 28 | 23 |
| SCH-W 50 | 40051720 | 5000 | 1350 | 900 | 28 | 32 |

¹The pressure force is reduced with a larger lift (loading case II to Euler)

Technical data SCH-W Siku

| Model | Art.-No. Siku | Tensile or pressure load ¹ kg | Rack length mm | Lift mm | Hand effort at WLL daN | Weight kg |
|-----------|------------------|---|-------------------|------------|---------------------------|--------------|
| SCH-W 100 | 40051722 | 10000 | 1550 | 1000 | 40 | 56 |

INFO

Please fill in the questionnaire on the next page for sluice gate jack systems.

Dimensions SCH-W

| Model | SCH-W 15 | SCHW-30 | SCHW-50 | SCH-W 100 |
|---------|----------|---------|---------|-----------|
| A, mm | 35 | 45 | 50 | 60 |
| B, mm | 25 | 30 | 40 | 50 |
| C, mm | 140 | 160 | 145 | 165 |
| D, mm | 85 | 60 | 45 | 65 |
| E, mm | 125 | 204 | 189 | 235 |
| F, mm | 78 | 92 | 100 | 112 |
| G, mm | 175 | 230 | 260 | 320 |
| H, mm | 310 | 395 | 400 | 480 |
| I, mm | 33.5 | 39.5 | 51 | 59 |
| J, mm | 43.3 | 53.1 | 69.5 | 88.3 |
| K, mm | 121 | 138 | 81 | 84 |
| L, mm | 230 | 230 | 230 | 290 |
| M, mm | 90 | 90 | 90 | 115 |
| N, mm | 153 | 158 | 173 | 183 |
| O, mm | 52.5 | 55 | 61 | 66 |
| P, mm | 52.5 | 55 | 64 | 70 |
| Ø Q, mm | 14 | 14 | 14 | 14 |
| R, mm | 7 | 7 | 7 | 8 |
| S, mm | 76.5 | 85.5 | 88 | 100 |
| T, mm | 100.5 | 108.5 | 120 | 140 |
| U, mm | 113 | 121 | 132 | 185 |
| V, mm | 86 | 94 | 105 | - |
| W, mm | 136 | 144 | 155 | - |
| X, mm | 130 | 130 | 130 | 250 |
| Y, mm | 250 | 250 | 250 | 300 |

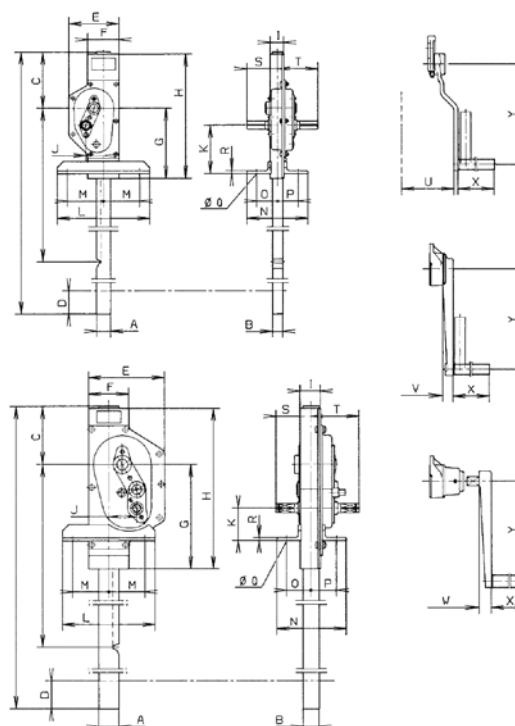

Technical questionnaire to identify a suitable sluice gate jack systems

Company: _____

Date: _____

Contact: _____

e-Mail: _____

Phone: _____

Fax: _____

Manual drive

Manual operating force _____ kN

Sluice gate

Thickness _____ mm

Material

Wood

Steel

Weight _____ kg

Friction coefficient

Steel/Wood

Steel/Rubber

Roller gate

Motor drive with manual emergency drive

Lifting speed Standard
_____ m/min

Operating voltage _____ V
_____ Hz

230/400 V, 50 Hz three-phase current

Motor rating

Load cycles per hour _____

Lift per load cycle _____

Surrounding temperature _____

Remark

Quantity

Indicate local conditions and water levels

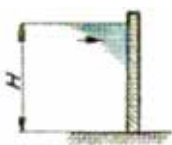

H = _____

without water below

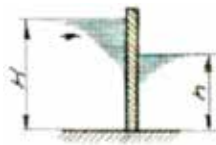

H = _____

h = _____

with water below

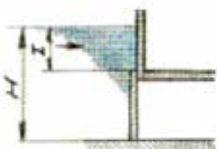

H = _____

l = _____

completely in water above

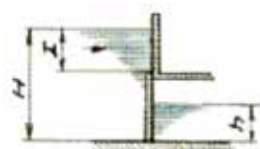

H = _____

l = _____

h = _____

completely in water above,
partly in water below

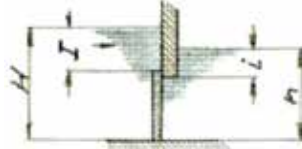

H = _____

l = _____

h = _____

i = _____

completely in water above
and in water below

Accessories

Lifting motion limitation

Electrical cut-out by safety clutch

Auma rotary drive

Technical questionnaire to identify a suitable sluice gate jack systems

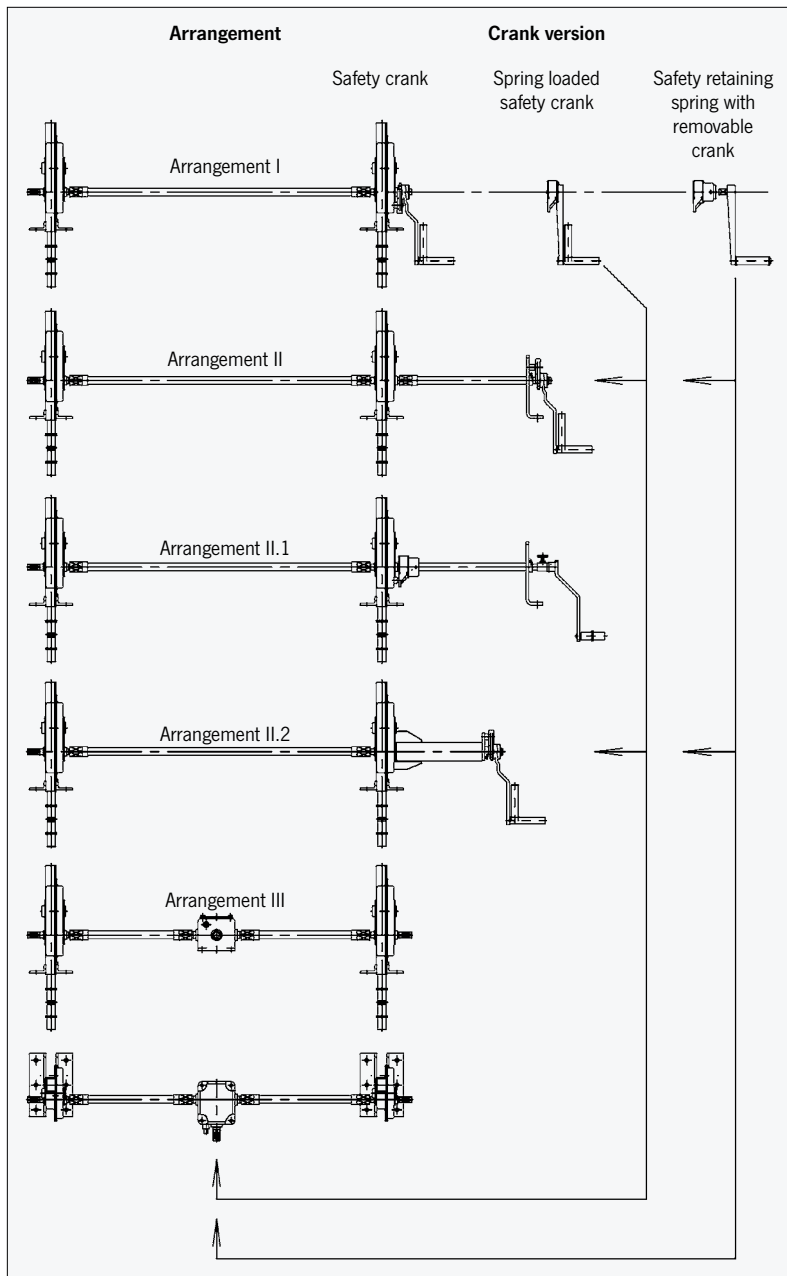

Arrangement

Crank version

(Retaining springs not possible for 10t model)

Date

Name

Application

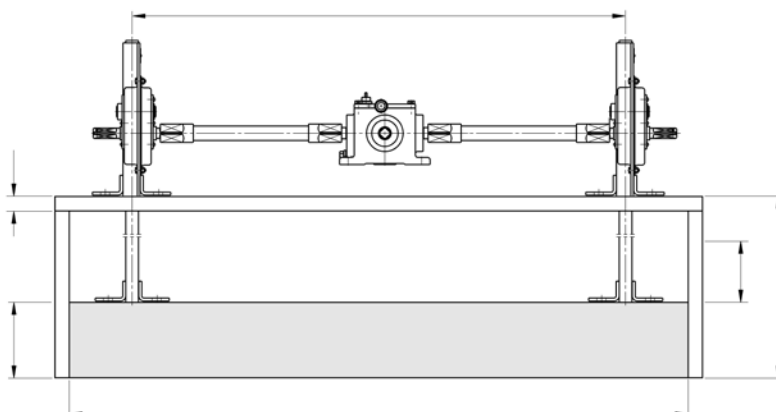

SAFE

This user information presents a general review regarding the application of cranes and does not substitute the existing operating instructions for specific products!

Lifting and slewing operations may be carried out by competent users (trained in theory and practice) only. When operated correctly, our cranes will offer the highest degree of safety in line with long life expectancy and avoid damage to products and people.

Yalesystems cranes are manufactured in accordance with the machinery directive 2006/42/EC and the latest DIN 15018 H2 B2 (gantry cranes H2 B3) and correspond to the VDE regulations.

All components are mechanically shot blast, then primed and coated with RAL 1023 (yellow) paint, D.F.T. approx. 60 micron.

Modification of delivery condition

Design and finish of the cranes may not be modified by e.g. installation of outside supplied parts, bending, welding, grinding, removal of parts, added bores, removal of safety devices like locking mechanisms, locking pins, safety latches etc.

Limitations of operation

Temperature

Cranes may normally be operated at ambient temperatures between -10 °C up to +50 °C. These values are approximate and may deviate from the specific givings of the product concerned. The accurate data are given in the current operating instructions.

Chemicals

Cranes may not be operated without hesitation in the area of chemicals or chemical vapours – consult our specialists for advice. Cranes which have been subject to chemicals or vapours must be taken out of service and inspected by us.

Transport of people

Transport of people with cranes is generally forbidden!

Operation in danger zones

Lifting or transport of loads must be avoided while personnel are in the danger zone. People are not allowed to pass over or under a suspended load.

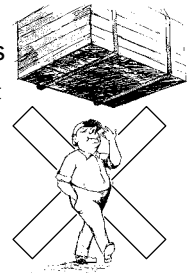

Electrical hazards

Please consult the specific operating instructions for possible electrical hazards. Electrical connections may only be performed by authorized persons resp. companies!

Maintenance and repair

To ensure safe operation, all cranes must be subjected to regular inspections according to the maintenance instructions given by the manufacturer. For legal obligations refer to DGUV Vorschrift 52 (BGV D6).

Depending on the frequency and impact of applications, the crane has to be maintained, at least once per year or in case of obvious damages, by competent persons resp. inspectors.

Repairs and inspections may only be carried out by competent persons resp. inspectors who use original spare parts. Repairs and inspections must be recorded consecutively.

Inspections

The contractor has to make sure that powered cranes are inspected prior to initial operation and after significant modifications by a competent person. This is also applicable for hand operated cranes with a capacity of more than 1000 kg.

For cranes according to § 3a para. 3 DGUV Vorschrift 52 (BGV D6) the inspection before initial operation consists of advance survey, inspection of building and quality acceptance.

The inspection prior to initial operation is not required for cranes, which are delivered ready-to-use and with certificate of a type approval or EC declaration of conformity.

INFO

For information on training please see page 4.

Technical questionnaire to identify the suitable crane system

Company: _____

Date: _____

Contact: _____

e-Mail: _____

Phone: _____

Fax: _____

- Wall-mounted jib crane
- Floor-mounted jib crane
- For outdoor use

Capacity (max.) _____ kg
 Slewing range _____
 Boom length A _____ mm
 Boom clearance UK _____ mm
 or: ceiling clearance H _____ mm
 or: overall height B _____ mm
 or: highest hook position _____ mm

Accessories

- Increased paint thickness
- Hot-dip galvanizing
- Boom locks
- Slewing range stoppers
- Electrically driven slewing gear
- Slewing brake, recommended for outdoor cranes and/or booms > 5 m

Power supply

- Round cable for booms ≤ 4.5 m
- Festooned cable, recommended for booms > 4.5 m
- Suspended control

Mounting for wall-mounted jib crane

- Threaded rods/anchor bolts
- Pillar embracing

Mounting for floor-mounted jib crane

- Anchors and template
- Standard base plate (welded) incl. anchors/rawplug
- Dowel base plate (bolted) incl. anchors/rawplug

Hoists

- Manual hoists
- Electric chain hoist (single speed)
- Electric chain hoist (2 speeds)

- Gantry crane

Capacity (max.) _____ kg
 Gantry width – inside – a _____ mm
 Gantry width – outside – A _____ mm
 Beam clearance UK _____ mm
 or: ceiling clearance H _____ mm
 or: overall height B _____ mm
 or: highest hook position _____ mm

Accessories

- Increased paint thickness
- Hot-dip galvanizing

Power supply

- Round cable for booms ≤ 4.5 m
- Festooned cable, recommended for booms > 4.5 m
- Suspended control

Trolleys

- With push trolley
- With geared trolley
- With electric trolley (single speed)
- With electric trolley (2 speeds)

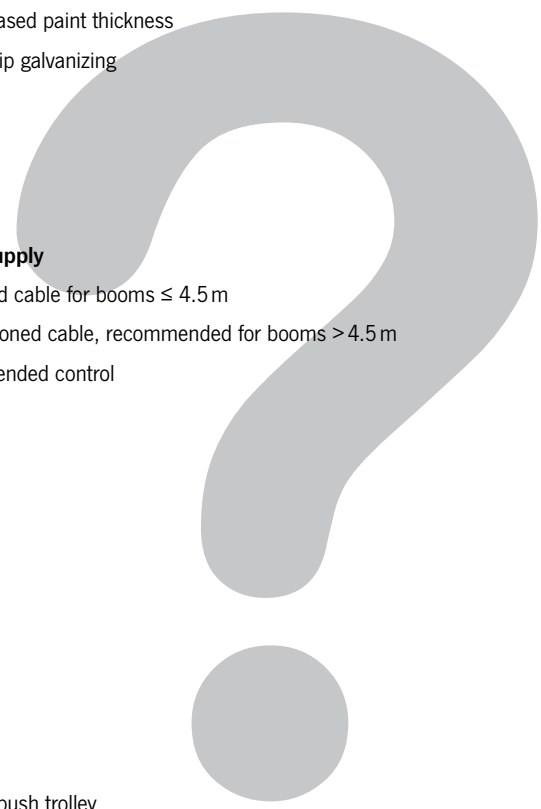

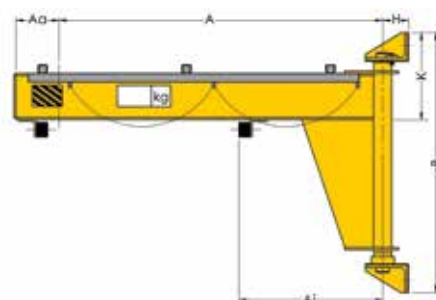
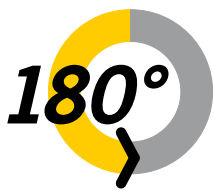

INFO

Mounting supports and walls are within the responsibility of the user.

Scope of delivery

- The electrical system is equipped with a lockable main switch, round cable power supply with cable support pipes for booms up to 4000 mm.
- From 4500 mm upwards, the boom is equipped with a festooned cable power supply. Due to cable sag on low cranes, we recommend the use of festooned cables even on short booms.
- Trolley stoppers at the front and at the back.
- Cranes are supplied with an operating manual and complete manufacturer’s documentation.

PMS

Wall-mounted jib crane

Elevated boom with optimal height, slewing range 180°

Lightweight, twist-free steel girder construction with low headroom. The boom is fitted with a bearing and a wall bracket for anchoring the crane to a concrete wall.

Mounting a jib crane to a wall, in combination with a festooned cable system, may lead to restrictions in the slewing range of the boom. This being the case, slew stoppers (buffers) should be fitted accordingly.

Mounting

- Wall mounting, using threaded rods that go through the wall and that are bolted to the wall with counter plates and nuts.
- Pillar embracing with anchor bolts and wall bracket. Bracket plate max. 500 mm, anchor bolts (threaded rods) max. 1000 mm.
- Alternative mounting systems on request.

Options

- Slew stoppers (buffers) can be fitted on building site for a pre-determined fixed slewing range.
- Slewing brake, to control the boom speed during slewing. Recommended for a boom length of more than 5 m or a headroom of more than 4 m. This prevents uncontrolled movement of the boom.
- Increased paint layer (120µm) or hot-dip galvanisation for outdoor use.
- Manual locking device, to hold the boom in a fixed position (wind protection).
- Hoist cover for outdoor use.

Standard delivery programme PMS

| Model | Capacity kg | Boom length in mm | | | | | | | | | | |
|----------|-------------|-------------------|------|------|------|------|------|------|------|------|------|------|
| | | 2000 | 2500 | 3000 | 3500 | 4000 | 4500 | 5000 | 5500 | 6000 | 6500 | 7000 |
| PMS 50 | 50 | • | • | • | • | • | • | • | • | • | • | • |
| PMS 80 | 80 | • | • | • | • | • | • | • | • | • | • | • |
| PMS 125 | 125 | • | • | • | • | • | • | • | • | • | • | • |
| PMS 200 | 200 | • | • | • | • | • | • | • | • | • | • | • |
| PMS 250 | 250 | • | • | • | • | • | • | • | • | • | • | • |
| PMS 400 | 400 | • | • | • | • | • | • | • | • | • | • | • |
| PMS 500 | 500 | • | • | • | • | • | • | • | • | • | • | • |
| PMS 800 | 800 | • | • | • | • | • | • | • | • | • | • | • |
| PMS 1000 | 1000 | • | • | • | • | • | • | • | • | • | • | • |
| PMS 1600 | 1600 | • | • | • | • | • | • | • | • | • | • | • |
| PMS 2000 | 2000 | • | • | • | • | • | • | • | • | • | • | • |
| PMS 2500 | 2500 | • | • | • | • | • | • | • | • | • | • | • |

Mounting systems wall-mounted jib cranes

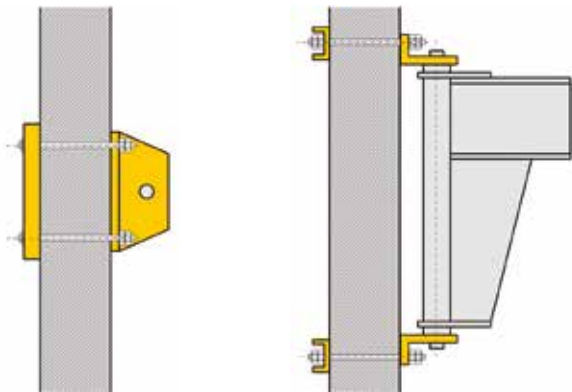

Wall mounting, using threaded rods going through the wall and being fixed to the wall with counter plates and nuts.

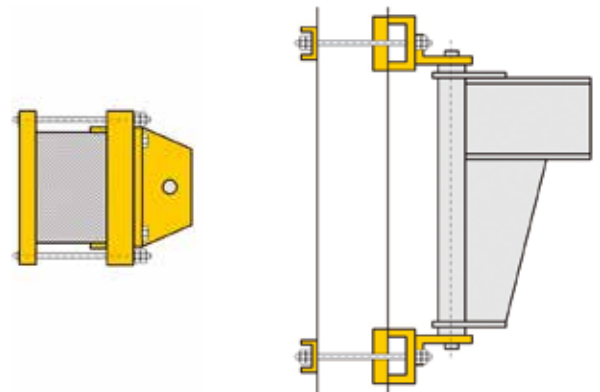

Pillar embracing with anchor bolts and wall bracket (bracket plate max. 500 mm, anchor bolts max. 1000 mm)

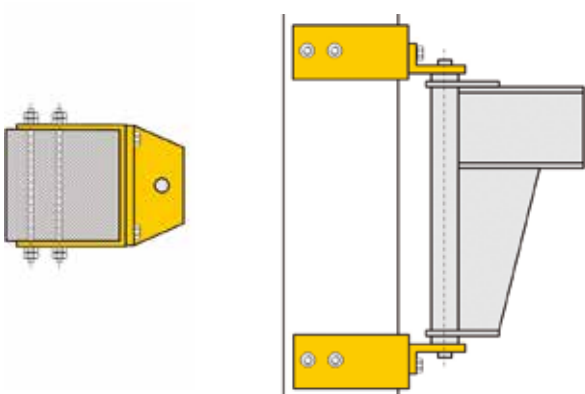
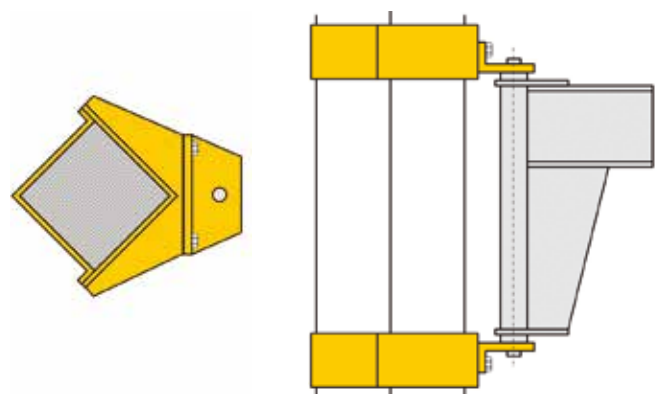
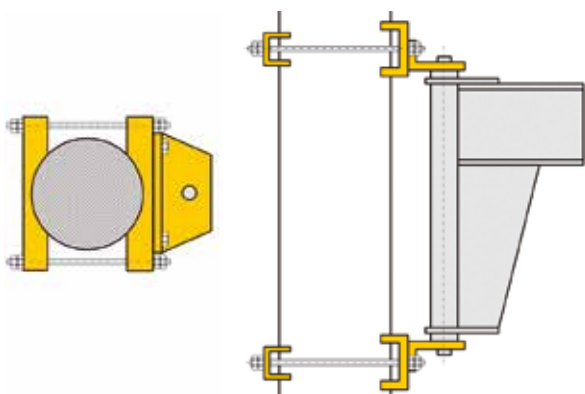

INFO

If wall-mounted jib cranes are mounted directly on the wall and festooned cable power supply is used, the slewing range may be limited depending on the size of the hoist.

Further fastening possibilities such as weld-on brackets, ceiling mounting etc. on request.

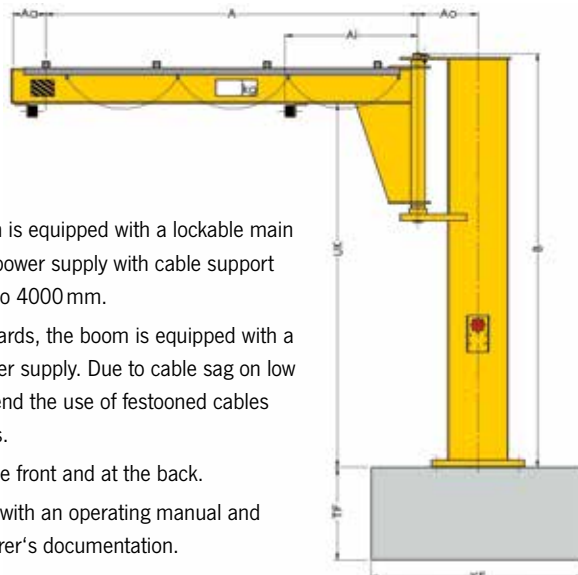
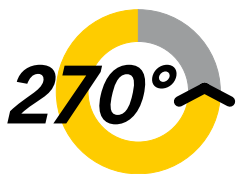

Scope of delivery

- The electrical system is equipped with a lockable main switch, round-cable power supply with cable support pipes for booms up to 4000 mm.
- From 4500 mm upwards, the boom is equipped with a festooned cable power supply. Due to cable sag on low cranes, we recommend the use of festooned cables even on short booms.
- Trolley stoppers at the front and at the back.
- Cranes are supplied with an operating manual and complete manufacturer’s documentation.

**PFSP
Floor-mounted jib crane**

Elevated boom with optimal height, slewing range 270°

Lightweight, twist-free steel girder construction with low headroom. The boom is fitted with a bearing, pillar made from reinforced steel pipe.

Depending on the size of the hoist and in combination with festooned power cables, restrictions in the slewing range of the boom may be possible.

Mounting

- Base flange with anchor bolts and template.
- Anchoring the base plate (welded) including mortar cartridges, anchor studs (complete with nuts, locknuts and washers).
- Anchoring the dowel base plate (bolted) including mortar cartridges, anchor studs (complete with nuts, locknuts and washers).
- Mobile unit for changeable location.

Options

- Slew stoppers (buffers) can be fitted on building site for a pre-determined fixed slewing range.
- Slewing brake, to control the boom speed during slewing. Recommended for a boom length of more than 5 m or a headroom of more than 4 m. This prevents uncontrolled movement of the boom.
- Increased paint layer (120µm) or hot-dip galvanisation for outdoor use.
- Manual locking device, to hold the boom in a fixed position (wind protection).
- Hoist cover for outdoor use.

INFO

Mounting systems, please see page 144.

Standard delivery programme PFSP

| Model | Capacity kg | Boom length in mm | | | | | | | | | | |
|-----------|-------------|-------------------|------|------|------|------|------|------|------|------|------|------|
| | | 2000 | 2500 | 3000 | 3500 | 4000 | 4500 | 5000 | 5500 | 6000 | 6500 | 7000 |
| PFSP 50 | 50 | • | • | • | • | • | • | • | • | • | • | • |
| PFSP 80 | 80 | • | • | • | • | • | • | • | • | • | • | • |
| PFSP 125 | 125 | • | • | • | • | • | • | • | • | • | • | • |
| PFSP 200 | 200 | • | • | • | • | • | • | • | • | • | • | • |
| PFSP 250 | 250 | • | • | • | • | • | • | • | • | • | • | • |
| PFSP 400 | 400 | • | • | • | • | • | • | • | • | • | • | • |
| PFSP 500 | 500 | • | • | • | • | • | • | • | • | • | • | • |
| PFSP 800 | 800 | • | • | • | • | • | • | • | • | • | • | • |
| PFSP 1000 | 1000 | • | • | • | • | • | • | • | • | • | • | • |
| PFSP 1600 | 1600 | • | • | • | • | • | • | • | • | • | • | • |
| PFSP 2000 | 2000 | • | • | • | • | • | • | • | • | • | • | • |
| PFSP 2500 | 2500 | • | • | • | • | • | • | • | • | • | • | • |

PFM Floor-mounted jib crane

Elevated boom with optimal height, slewing range 360°

Lightweight, twist-free steel girder construction with low headroom. Compact rotating head for ideal construction dimensions; access from above ensures easy assembly. The boom is fitted with a roller bearing, pillar made from reinforced steel pipe.

Depending on the size of the hoist and in combination with festooned power cables, restrictions in the slewing range of the boom may be possible.

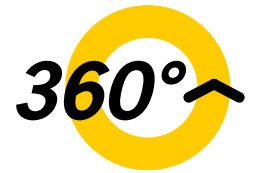

Mounting

- Base flange with anchor bolts and template.
- Anchoring the base plate (welded) including mortar cartridges, anchor studs (complete with nuts, locknuts and washers).
- Anchoring the dowel base plate (bolted) including mortar cartridges, anchor studs (complete with nuts, locknuts and washers).
- Mobile unit for changeable location.

Options

- Slew stoppers (buffers) can be fitted on building site for a pre-determined fixed slewing range.
- Slewing brake, to control the boom speed during slewing. Recommended for a boom length of more than 5 m or a headroom of more than 4 m. This prevents uncontrolled movement of the boom.
- Increased paint layer (120 µm) or hot-dip galvanisation for outdoor use.
- Manual locking device, to hold the boom in a fixed position (wind protection).
- Hoist cover for outdoor use.

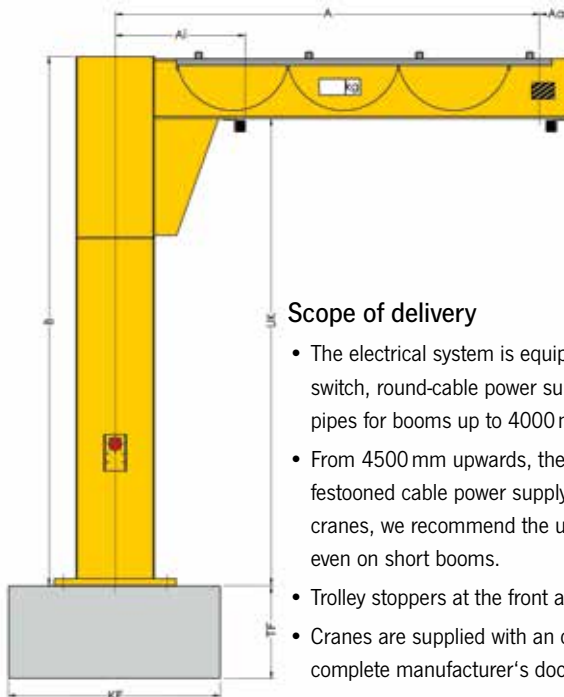

Scope of delivery

- The electrical system is equipped with a lockable main switch, round-cable power supply with cable support pipes for booms up to 4000 mm.
- From 4500 mm upwards, the boom is equipped with a festooned cable power supply. Due to cable sag on low cranes, we recommend the use of festooned cables even on short booms.
- Trolley stoppers at the front and at the back.
- Cranes are supplied with an operating manual and complete manufacturer's documentation.

INFO

Mounting systems, please see page 144.

Standard delivery programme PFM

| Model | Capacity kg | Boom length in mm | | | | | | | | | | |
|----------|-------------|-------------------|------|------|------|------|------|------|------|------|------|------|
| | | 2000 | 2500 | 3000 | 3500 | 4000 | 4500 | 5000 | 5500 | 6000 | 6500 | 7000 |
| PFM 50 | 50 | • | • | • | • | • | • | • | • | • | • | • |
| PFM 80 | 80 | • | • | • | • | • | • | • | • | • | • | • |
| PFM 125 | 125 | • | • | • | • | • | • | • | • | • | • | • |
| PFM 200 | 200 | • | • | • | • | • | • | • | • | • | • | • |
| PFM 250 | 250 | • | • | • | • | • | • | • | • | • | • | • |
| PFM 400 | 400 | • | • | • | • | • | • | • | • | • | • | • |
| PFM 500 | 500 | • | • | • | • | • | • | • | • | • | • | • |
| PFM 800 | 800 | • | • | • | • | • | • | • | • | • | • | • |
| PFM 1000 | 1000 | • | • | • | • | • | • | • | • | • | • | • |

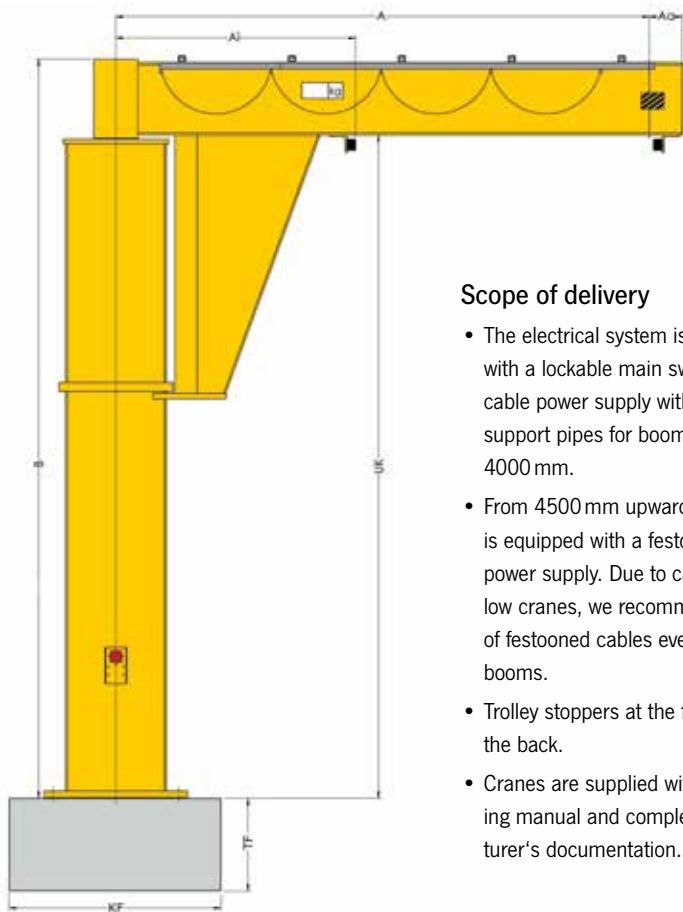
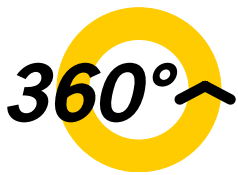

Scope of delivery

- The electrical system is equipped with a lockable main switch, round-cable power supply with cable support pipes for booms up to 4000 mm.
- From 4500 mm upwards, the boom is equipped with a festooned cable power supply. Due to cable sag on low cranes, we recommend the use of festooned cables even on short booms.
- Trolley stoppers at the front and at the back.
- Cranes are supplied with an operating manual and complete manufacturer's documentation.

PFP

Floor-mounted jib crane

Elevated boom with optimal height, slewing range 360°

Heavy, robust twist-free steel girder construction. Structural steel crane-boom. Compact rotating head for ideal construction dimensions; access from above ensures easy assembly. The boom is fitted with a roller bearing, pillar made from reinforced steel pipe.

Depending on the size of the hoist and in combination with festooned power cables, restrictions in the slewing range of the boom may be possible.

Mounting

- Base flange with anchor bolts and template.
- Anchoring the dowel base plate (bolted) including mortar cartridges, anchor studs (complete with nuts, locknuts and washers).

Options

- Electrically driven slewing gear.
- Slew stoppers (buffers) can be fitted on building site for a pre-determined fixed slewing range.
- Limit switches to limit the boom slewing range (before hitting a fixed object the motor switches off automatically).
- Increased paint layer (120µm) or hot-dip galvanisation for outdoor use.
- Manual locking device, to hold the boom in a fixed position (wind protection).
- Hoist cover for outdoor use.

Standard delivery programme PFP

| Model | Capacity kg | Boom length in mm | | | | | | | | | | |
|----------|-------------|-------------------|------|------|------|------|------|------|------|------|------|------|
| | | 2000 | 2500 | 3000 | 3500 | 4000 | 4500 | 5000 | 5500 | 6000 | 6500 | 7000 |
| PFP 500 | 500 | • | • | • | • | • | • | • | • | • | • | • |
| PFP 800 | 800 | • | • | • | • | • | • | • | • | • | • | • |
| PFP 1000 | 1000 | • | • | • | • | • | • | • | • | • | • | • |
| PFP 1600 | 1600 | • | • | • | • | • | • | • | • | • | • | • |
| PFP 2000 | 2000 | • | • | • | • | • | • | • | • | • | - | - |
| PFP 2500 | 2500 | • | • | • | • | • | • | • | - | - | - | - |
| PFP 3200 | 3200 | • | • | • | • | • | - | - | - | - | - | - |

Safety distances in accordance with the accident prevention regulations for cranes DGUV Vorschrift 52 (BGV D6) § 11 and § 32

The following safety distances are only valid for floor-controlled cranes, without platforms, walkways or similar, on the jib with a load capacity of less than 10 t.

| Movement manual | Safety distance | | |
|-----------------|-----------------|-----------|-------------|
| | So = Top | Ss = Side | Su = Bottom |
| Lifting | 100* | 100* | 100* |

| Movement power-driven, floor-controlled | Safety distance | | |
|---|-----------------|------------|-------------|
| | So = Top | Ss = Side | Su = Bottom |
| Lifting | 100* | 100* | 100* |
| Lifting and travelling | 100* | 100* | 500 |
| Lifting, travelling and slewing | 100* | 100* (500) | 500 |

Safety distances for cranes with a load capacity up to 10000 kg
 *No regulation (100 mm recommended)

Ss... for power-driven slewing motion, the safety distance must be complied with, if the possible crushing point is within the traffic and working area.

In general, the traffic and working area ranges from the upper edge of the ground up to 2.5m room height.

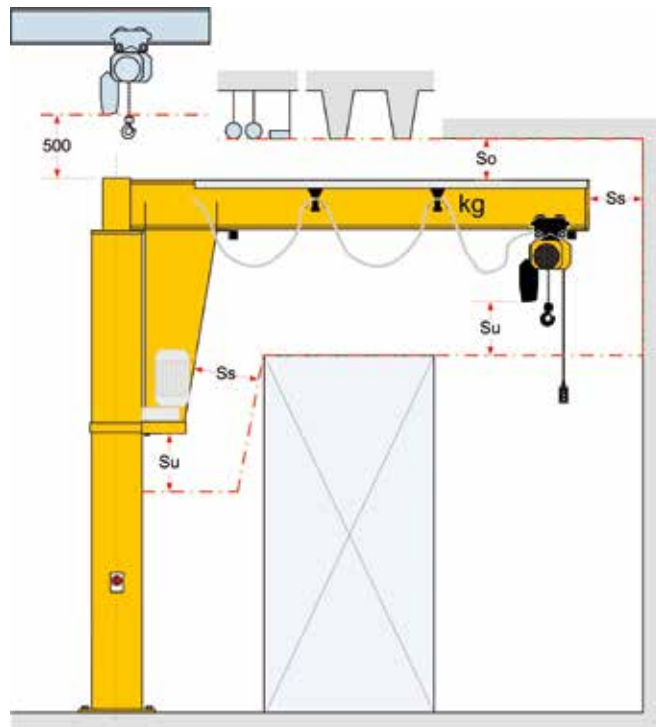

Mounting systems for floor-mounted jib cranes

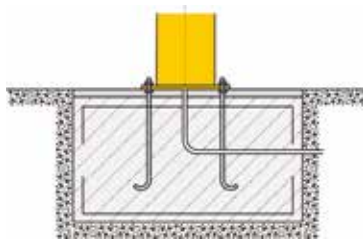

Anchor bolts with template for preparation of the foundation through the customer.

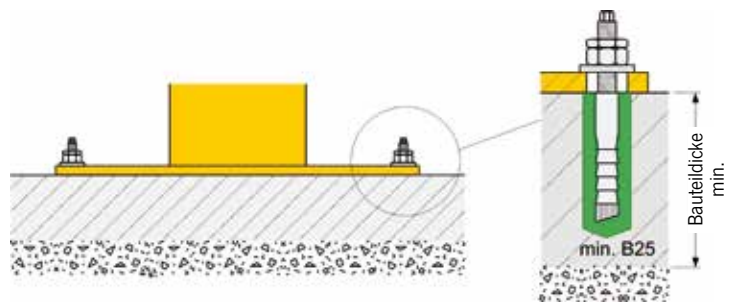

Standard base plate (welded) for anchor-bolt connection on existing concrete floor instead of welded-on base flange (only for operation inside a building) incl. HVZ dynamic anchor bolts.

INFO

Further capacities and boom lengths on request.

Further fastening possibilities such as weld-on brackets, ceiling mounting etc. on request.

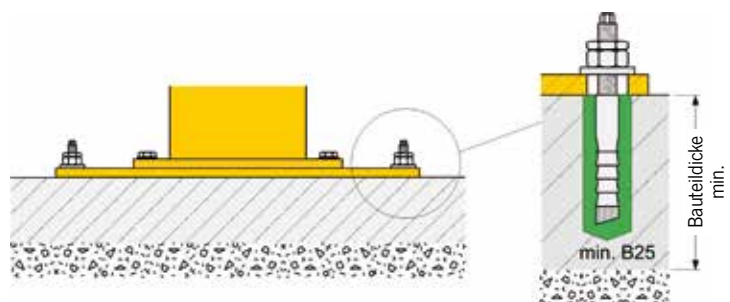

Dowel base plate for anchor-bolt connection on existing concrete floor (only for operation inside a building) incl. HVZ dynamic anchor bolts.

INFO

Operating conditions for standard and intermediate base plates

- The thickness of the concrete floor slab for M 12 x 95 HVC dynamic anchor bolts must be min. 190 mm.
- The thickness of the concrete floor slab for M 16 x 105 HVC dynamic anchor bolts must be min. 210 mm.
- The concrete floor slab must be horizontal and even.
- The concrete quality must meet min. B25 or C20/25.
- Mounting with through bolts consisting of base plate, through bolts and counter plates (for ceiling thicknesses up to 350 mm).
- Floor/wall mounting or floor/ceiling mounting on request.

INFO

Plate dimensions, quantity, dimension and position of the chemical anchors depend on the crane type, load capacity and boom length of the crane (details and technical data according to the relevant crane data sheet).

Due to cable sag, we recommend that on low cranes festooned cables be used, even for a short boom length.

Base plate for fastening pillar-mounted slewing jibs and slewing cranes without foundation

Some pillar-mounted slewing jibs and slewing cranes can be mounted by means of a standard base plate or an dowel base plate. No foundation is required, easy and quick assembly on the customer's existing reinforced concrete slab is possible. **Potential tripping hazard by protruding locknuts, unmarked or unsecured plate edges must be clearly marked.**



- The installation location of the crane must be selected in such a way that the base plate is mounted outside of traffic routes according to the German regulations for workplaces AStV para. 2. If this is not possible, the plate must be secured or marked in such a way that a hazard is avoided (e.g. by warning hatching along the edge of the plate).
- The base plate with tripping points must not protrude into escape routes or limit their prescribed min. widths.
- The measures for reducing hazards caused by tripping points must be taken by the operating company in cooperation with the safety expert.
- A warning sign as hazard reduction is a minimal measure and may not be sufficient in certain cases (e.g. in spite of warning signs, tripping incidences occur frequently, the warning sign is not recognised sufficiently in advance).

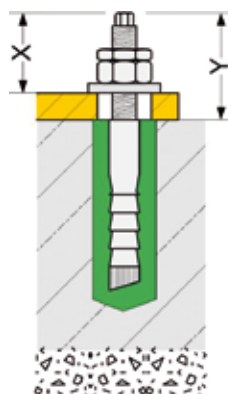

The smallest possible projection of the chemical anchor over the crane base plate "X" with an M12 anchor is approx. 33 mm, with M16 approx. 37 mm. This dimension can only be reached, if the concrete floor slab exceeds the above-mentioned min. thickness. The max. projection of the chemical anchor, measured

from floor level "Y", is approx. 73 mm for M12 anchors and approx. 86 mm for M16 anchors, with the relevant min. floor slab thickness.

TDL

Moveable gantry crane

Yalesystems gantry crane for use in all areas, from craftsman's workshops, garages and industrial use. They are suitable for low to medium weight capacities and are also for outdoor use.

The cranes are moved by hand and are not dependant on a rail system.

The guidelines for moving Yalesystems gantry cranes and transporting loads should be strictly followed.

Options

- Increased paint layer (120µm) or hot-dip galvanisation for outdoor use.
- Hoist cover for outdoor use.

Scope of delivery

- 3-part construction with 2 robust rectangular steel-bar supports and 1 load carrier beam.
- Manually moveable
- Parking brake by threaded spindle.
- Power supply by festooned cables incl. flat cables, C type mounting rail, cable trolley, support arms and towing trolleys.
- Cranes are supplied with an operating manual and complete manufacturer's documentation.



INFO

Further capacities and boom lengths on request.

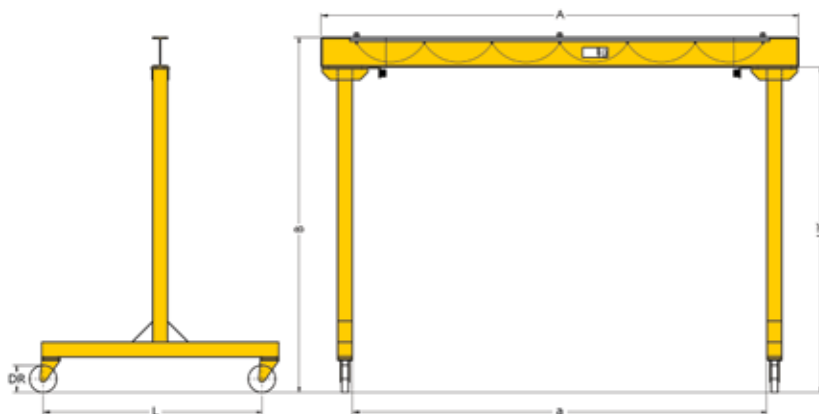

Standard delivery programme TDL

| Model | Capacity kg | Boom length in mm | | | | | | | |
|----------|-------------|-------------------|------|------|------|------|------|------|------|
| | | 2500 | 3000 | 3500 | 4000 | 4500 | 5000 | 5500 | 6000 |
| TDL 500 | 500 | • | • | • | • | • | • | • | • |
| TDL 1000 | 1000 | • | • | • | • | • | • | • | • |
| TDL 2000 | 2000 | • | • | • | • | • | • | • | • |
| TDL 3200 | 3200 | • | • | • | • | • | • | • | • |

Boom clearance (UK): Standard 2500 mm, other dimensions on request.

Gantry width - inside (dimension a):

TDL-500/TDL-1000: Boom length A less 455 mm

TDL-2000/TDL-3200: Boom length A less 500 mm

Festooned cable system

The Yale festooned cable system kit contains all the parts necessary to install a power supply.

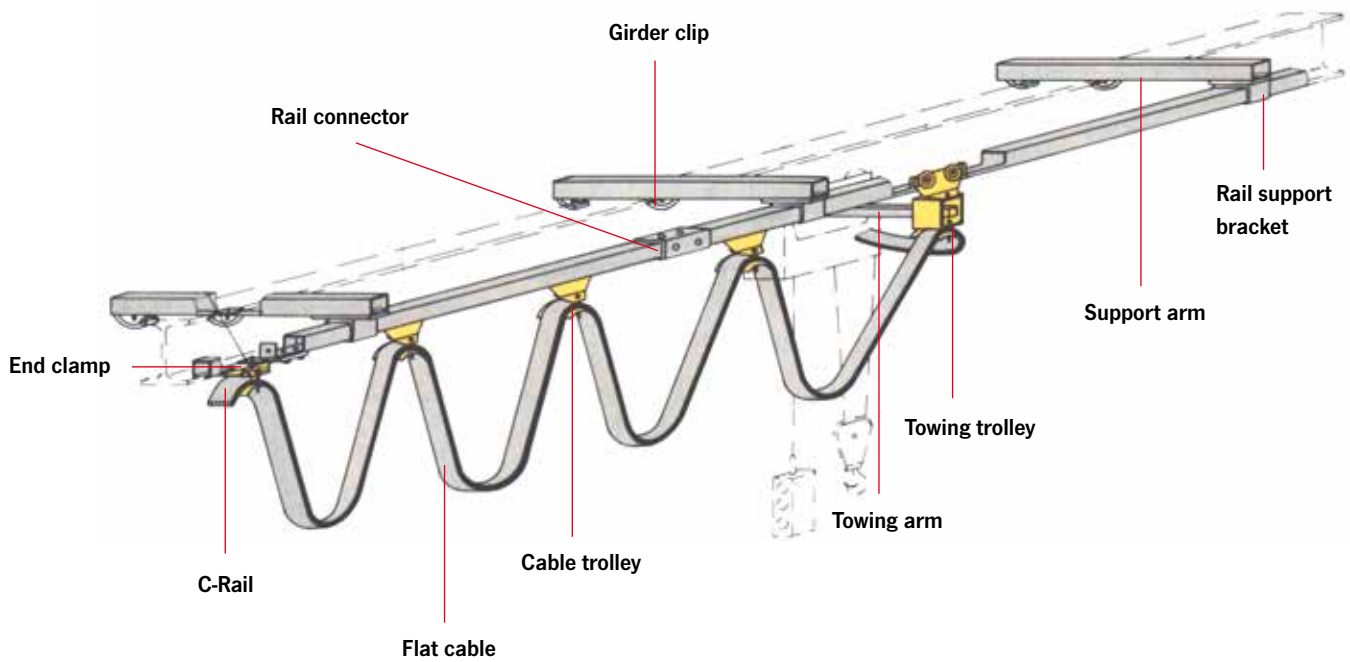

INFO

Quantity of units dependant on track length.

Features

- The PVC flat cable 4 x 2.5 mm² is suitable for all electric hoists with a power consumption of up to 25 A.
- The line sag is 700 mm. The cable and towing trolleys are made from plastic and can carry loads of up to 10 daN.
- The rollers are fitted with bronze bushes resp. ball bearings.
- The C-rail, rail support brackets and rail connectors are zinc-plated for added protection against corrosion.

Options

- Mounting kit consisting of support arm and girder clips for connection to the beam.
- Towing arm for towing trolley.

Scope of delivery

- 1 End clamp
- 1 End stop
- 1 Towing trolley
- 2 End caps
- 2 FI-fittings with locknuts
- 1 Main switch 400V, 50 Hz



Main switch

Scope of delivery festooned cable systems

| Model | Art.-No. | Art.-No. Mounting kit | C-rails track length m | Transport distance max. m | PVC flat cable m | Numbers of cable trolleys | Rail support bracket | Rail connector |
|--|-----------|-----------------------|------------------------|---------------------------|------------------|---------------------------|----------------------|----------------|
| Festooned cable 4 m C-rail track length | N07700001 | N07700010 | 4 | 3.5 | 9 | 2 | 4 | 0 |
| Festooned cable 6 m C-rail track length | N07700002 | N07700011 | 6 | 5.4 | 11 | 3 | 5 | 1 |
| Festooned cable 8 m C-rail track length | N07700003 | N07700012 | 8 | 7.3 | 13 | 5 | 6 | 1 |
| Festooned cable 10 m C-rail track length | N07700004 | N07700013 | 10 | 9.2 | 15 | 6 | 7 | 2 |
| Festooned cable 12 m C-rail track length | N07700005 | N07700014 | 12 | 11.0 | 17 | 8 | 8 | 2 |
| Festooned cable 14 m C-rail track length | N07700006 | N07700015 | 14 | 12.9 | 19 | 9 | 9 | 3 |
| Festooned cable 16 m C-rail track length | N07700007 | N07700016 | 16 | 14.8 | 21 | 11 | 10 | 3 |
| Festooned cable 18 m C-rail track length | N07700008 | N07700017 | 18 | 16.7 | 23 | 12 | 11 | 4 |
| Festooned cable 20 m C-rail track length | N07700009 | N07700018 | 20 | 18.5 | 25 | 14 | 12 | 4 |



Cable trolley



Towing trolley



Rail support bracket



Rail connector



C-Rail

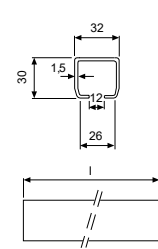
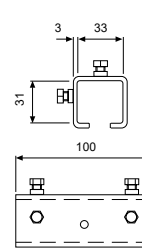
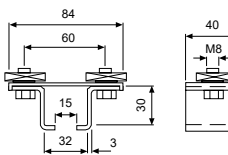
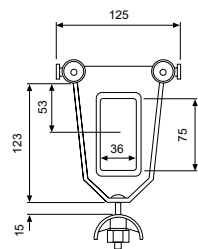
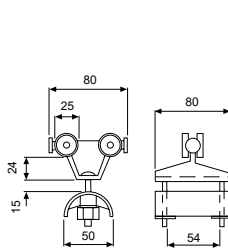

INFO

Optional: Mounting kit consisting of support arm and girder clips for connection to the beam.

Special applications e.g. for curves or cable trolley for round cables on request.

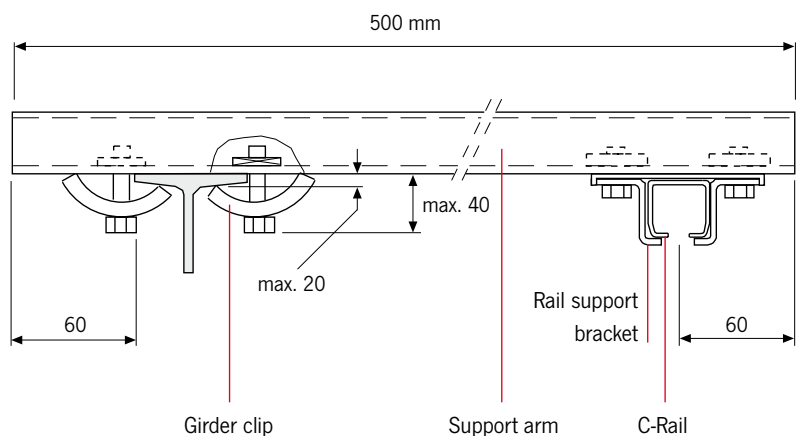

Tigrip® Load Hoisting Tackle

Tigrip® Lifting clamps and attachments have a reputation for reliability, quality and safety going back more than 35 years.

For transportation and handling of loads with a hoist the Tigrip® programme offers the optimum connection between hook and load for almost any application.

Tigrip® Crane Weighers

Also renowned for many years are our precise crane weighers. Wherever weight has to be measured or forces have to be assessed the reliable and robust units can be used. Areas of application are practically unlimited.

Tigrip® - your first choice!

Table of contents

| | Page |
|--|-----------|
| Grabs & Clamps | 154 - 159 |
| | 164 - 185 |
| Permanent load lifting magnets | 160 - 163 |
| Lifting lugs & Clamps & C-hooks | 186 - 190 |
| Barrel grabs & Crate grabs | 192 - 197 |
| Load hoisting tackle for underground construction | 198 - 201 |
| Spreader beams | 202 - 211 |
| Crane forks | 212 - 213 |
| Crane weighers | 214 - 217 |
| Load indicator | 218 - 219 |

INFO

Please note our user instructions at the beginning of each chapter.

Yale

TIGRIP®



TIGRIP
Mod. TBL 1.5 plus BJ 13
Ser No. see side plate
Tragt/WLL see side plate
Greif/Jaw Cap
Eigengew./Weight 1.5 t
0-20 mm
3.0 kg
CE COLUMBUS MCKINNON
Ind. Products GmbH
42549 Velbert/Germany
Bedienungsanleitung beachten!
Use Operating Instructions!



This user information presents a general overview regarding the operation of some plate clamps and does not substitute the existing operating instructions for specific load hoisting tackle!

Lifting operations with load hoisting tackle may be carried out by competent persons (trained in theory and practice) only.

When operated correctly, our Tigrip products will offer the highest degree of safety, avoid damage to products and people and present a long life expectancy.

Modification of delivery condition

Design and construction of the load hoisting tackle may not be altered without authorization of the manufacturer, e.g. by bending, welding, grinding, cutting-off parts, adding boreholes, removal of safety devices like locking mechanisms, bolts, shear pins etc. Otherwise the validity of the declaration of conformity will be void and any liability and warranty of the manufacturer ceased.

Limitations of operation

Loading

The rated capacity (WLL) indicated on the tackle is the maximum load which must not be exceeded.

Temperature

Clamps without protective lining may normally (depending on manufacturer) be operated at ambient temperatures of -40 °C up to +100 °C without capacity reduction. Clamps with protective lining may be subject to reduced temperature areas due to application of affixed linings, e.g. model TBP and TSB, which can be operated from -20 °C up to +40 °C.

Shock loading, swinging of load

The indicated capacities are based on shock-free loading of the tackle. Light bumps as occurred during lifting and lowering as well as transporting of load with the crane are admitted. Heavier shock loadings (e.g. crashing against obstacles during transport) as well as swinging of the load are strictly forbidden!

Chemicals

Load hoisting tackle may not be operated without hesitation in the area of chemicals or chemical vapours – consult our specialists beforehand. Hoisting tackle which has been subject to chemicals or vapours must be taken out of service and should be returned to us for inspection.

Transport of people

Transport of people with hoisting equipment and tackle is generally forbidden!

Operation in danger zones

Lifting or transport of loads must be avoided while personnel are in the danger zone. When using clamps or grabs without a positive fit but with force fit or friction fit the load must not be suspended above people – see AMVO §18(6)!

Lifting products

Load hoisting tackle have been designed for specific applications and must not be used for other jobs without prior authorization of the manufacturer. This refers e.g. to the thickness of material (jaw capacity of the clamp), surface condition, hardness* and temperature of material. Relative information is given in the respective operating instructions. These have to be available to the operator to ensure safe handling of the product.

*Please observe that for special steel plates the surface hardness may deviate substantially from the core hardness, e.g. for cold work steel.

Inspection before initial operation

- Ensure that the surface of the steel plate, in the area where the clamp is to be attached, is dry and free from grease, paint, dirt and scale and is not coated, so that the teeth resp. the protective lining on the moving jaw can make good contact with the surface of the load.
- Check the fixed jaw and the moving jaw for wear and defects. Both jaws must have clean profiles and teeth must not be heavily worn (observe respective advice given in the operating instruction, guiding value max. 30% wear). Protective linings must not be contaminated, damaged, uneven or heavily worn.
- The entire hoisting tackle has to be checked for damage, corrosion, cracks or deformations.
- It should be easy to open and close the clamp.
- Check the function of the spring. In the CLOSED position this must present a noticeable spring pressure force when the hook ring is pressed down.

Application advice

- Load hoisting tackle must always be in perfect condition and provided with a legible identity plate.
- Prior to initial operation and every time before work, the tackle is to be visually inspected for obvious deficiencies!
- The suspension eye must have sufficient space in the load hook and move freely. A safety latch to prevent accidental out-hooking of the tackle must be available!
- Do not lift or transport loads while personnel are in the danger zone and do not allow people to pass under a suspended load. Note: a safe form-fit attachment requires sufficient hardness of the load. Ensure that the load or parts thereof cannot slip and fall down!
- The load hoisting tackle must be positioned over the gravity centre of the load, so that a swinging movement is avoided.
- If longer sheets of metal or profiles are to be transported, we recommend using two clamps to prevent load swinging. The clamps can be used in combination with a spreader beam or with double strand chain slings and clamps with hinged hook ring (e.g. model TBS). Observe the maximum angle from the vertical and possible capacity restrictions.
- Clamps without hinged hook ring must not be loaded laterally! (Slanted attachment of the clamp onto the steel plate in pulling direction of the clamp is normally not permitted, as the jaws would grip too close to the edge of the plate. Thus a correct fit of the clamp on the plate is not assured!)

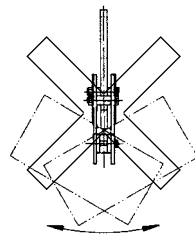

- Always insert the load fully into the mouth of the clamp and make sure that the housing has contact on either side of the plate.
- Clamps designed for the transport of steel plate in vertical position may only accept one single plate at a time. The clamping effect must be assured on either side of the load!
- Special clamps are available for the transport of steel plate in horizontal position which allows handling of several plates at a time.
- A load must not be suspended or left unattended in raised or tensioned condition for a longer period of time.
- When attaching the clamp, the operator must ensure that neither the clamp, slings or load pose a danger to himself or other personnel.
- The operator may not move the load until he is convinced that the load is correctly attached and all personnel are outside the danger zone.
- Please take note of possible capacity restrictions depending on the pivoting range resp. pulling direction of the clamp. (Note: Not all clamp types on the market are designed for a pivoting range of 180° – strictly observe the operating instructions!)
- In case of malfunction stop using the load hoisting tackle immediately.

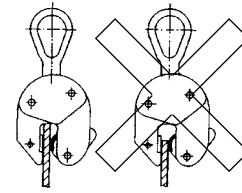

INFO

Due to the limitations of space in this catalogue we could not respond to all applications. Please contact us for further information!

OPERATION

Maintenance and repair

- To ensure safe operation, all load hoisting tackle must be subjected to regular inspections according to the maintenance instructions given by the manufacturer.
- Load hoisting tackle which are due for maintenance (normally once per year, unless adverse working conditions dictate shorter periods) or products with obvious defects may be returned to us for inspection and repair.
- Inspections and tests must be performed by competent persons or specialist workshops that use original spare parts.

Inspections

- Inspections are visual and functional and shall establish that the load hoisting tackle is safe and has not been damaged by incorrect transport or storage. In addition check for damage, wear, corrosion and other deficiencies as well as completeness and function of safety devices. Inspections are instigated by the user.
- All load hoisting tackle has to be cleaned prior to inspection. The cleaning procedure must not cause chemical damages (e.g. no acid – embrittlement), no incorrect temperature stress by e.g. flame cleaning or possible concealment of cracks due to excessive material loss (sand blasting)! We shall be pleased to consult you in this respect. Please submit your load hoisting tackle for inspection in clean condition. This will reduce inspection costs considerably!

Criteria for disposal of load hoisting tackle

Load hoisting tackle must no longer be operated if e.g.:

- The identification (identity plate) is missing or illegible.
- Housing, components and suspension of the tackle present obvious deficiencies, e.g. cuts, grooves, cracks, excessive corrosion, staining due to heat, signs of subsequent welding resp. spatters (which cannot be easily removed) and leave stains.
- Ropes show breakages of wires resp. bruises (criteria for disposal of ropes are given in classification DIN 15020), damages to the rope sleeve and similar failures.
- The load chain presents twisted or distorted links or shows an elongation of 5% resp. undergoes the averaged nominal thickness of the link by more than 10%.
- The opening (C) of either suspension or load hook has increased/deformed by more than 10% of the nominal dimension or shows wear in the hook mouth (dimensions B resp. D) of more than 5%.
- If the inspection revealed that the tackle has been overloaded or deteriorated it can only be used again after careful inspection and repair – if necessary.

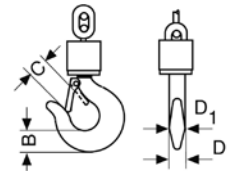

Technical questionnaire to identify the suitable Tigrip® load hoisting tackle

Company: _____ Date: _____
 Contact: _____ e-Mail: _____
 Phone: _____ Fax: _____

Clamps and grabs

Information about the load:

What will be transported?

Weight min. _____ kg - max. _____ kg
 Length min. _____ mm - max. _____ mm
 Width min. _____ mm - max. _____ mm
 Height min. _____ mm - max. _____ mm
 External diameter min. _____ mm - max. _____ mm
 Internal diameter min. _____ mm - max. _____ mm

Material Steel Concrete Wood Paper Others

Surface hardness for steel: _____ HRC

Surface condition Oiled Greasy Dry Scales Others

How should/may the load be grabbed/clamped:

Grabbed from underneath Jaws Protective lining Others

Information about the clamp/grab:

What kind of grab will be needed?

Type of crane hook or dimensions A - B

Model: _____ A = _____
 B = _____

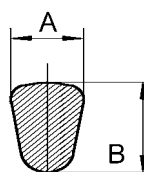

Other restrictions: _____



TBL/TBL plus Plate clamp with safety lock

Capacity 500 - 3000 kg

This clamp is primarily used for transporting single steel plates in the vertical position, as well as lifting and turning through 180°. This clamp can also be used for transporting steel constructions and profiles. It is recommended to use a pair of plate clamps in conjunction with a spreader beam for large sized sheets and long materials which have a tendency to sag.

The jaw can be opened and closed with the locking lever (except for the TBL 0.5t which uses a positive spring-loaded cam). The safety lock overrides the spring-loaded cam, preventing the clamp from opening even when there is no load.

This plate clamp is service-friendly, making it easy to exchange parts, which are available individually or in kits. Clamp repair is available by the factory, or can be done by certified and experienced staff.

The TBL 0.5 is equipped with a safety lock (positive spring-loaded cam), but comes without locking lever.

INFO

The surface hardness of the material must not exceed HRC 30/Brinell 300.

The min. load is 10% of the nominal WLL. Except for model TBL 1,5 plus, the min. load here is 100 kg!

Technical data TBL/TBL plus

| Model | Art.-No. | Capacity kg | Jaw capacity Z mm | Weight kg |
|--------------|-----------|-------------|-------------------|-----------|
| TBL 0,5 | N50100051 | 500 | 0 - 16 | 1.5 |
| TBL 1,5 plus | N50100056 | 1500 | 0 - 20 | 3.0 |
| TBL 2,0 plus | N50100057 | 2000 | 0 - 32 | 9.3 |
| TBL 3,0 plus | N50100058 | 3000 | 0 - 32 | 9.3 |

Dimensions TBL/TBL plus

| Model | TBL 0,5 | TBL 1,5 plus | TBL 2,0 plus | TBL 3,0 plus |
|---------|---------|--------------|--------------|--------------|
| A, mm | 99 | 126 | 192 | 192 |
| B, mm | 195 | 225 | 312 | 312 |
| Ø C, mm | 29 | 50 | 80 | 80 |
| D, mm | 33 | 49 | 75 | 75 |
| E, mm | 47 | 70 | 96 | 96 |
| F, mm | 50 | 82 | 100 | 100 |
| G, mm | 48 | 55 | 81 | 81 |
| H, mm | 11 | 12 | 20 | 20 |
| I, mm | 16 | 20 | 24 | 24 |

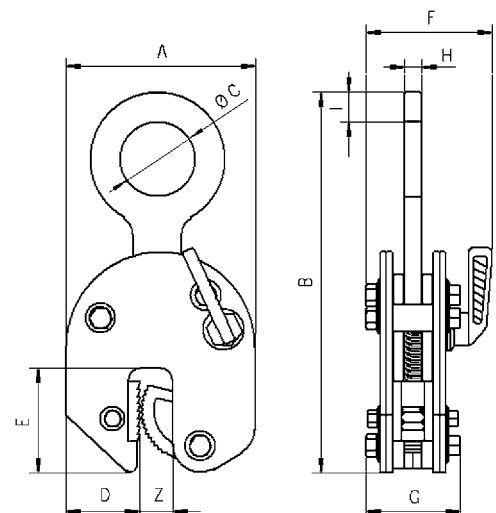

TBL
Plate clamp
with safety lock

Capacity 4000 - 30000 kg

This clamp is primarily used for transporting single steel plates in the vertical position, as well as lifting and turning through 180°. This clamp can also be used for transporting steel constructions and profiles. It is recommended to use a pair of plate clamps in conjunction with a spreader beam for large sized sheets and long materials which have a tendency to sag.

These plate clamps have the same design and applications as the clamp model TBL with a capacity from 500 - 3000 kg.



INFO

The surface hardness of the material must not exceed HRC 30/Brinell 300.

The min. load is 10% of the nominal WLL!

Technical data TBL

| Model | Art.-No. | Capacity kg | Jaw capacity Z mm | Weight kg |
|------------|-----------|-------------|-------------------|-----------|
| TBL 4,0 S | N50100005 | 4000 | 0 - 32 | 11.2 |
| TBL 4,0 L | N50100006 | 4000 | 30 - 60 | 11.9 |
| TBL 6,0 S | N50100021 | 6000 | 0 - 50 | 20.6 |
| TBL 6,0 L | N50100008 | 6000 | 50 - 100 | 23.2 |
| TBL 8,0 S | N50100022 | 8000 | 0 - 50 | 24.2 |
| TBL 8,0 L | N50100023 | 8000 | 50 - 100 | 28.8 |
| TBL 10,0 S | N50100024 | 10000 | 0 - 50 | 29.5 |
| TBL 10,0 L | N50100025 | 10000 | 50 - 100 | 35.1 |
| TBL 15,0 S | N50100015 | 15000 | 0 - 50 | 76.0 |
| TBL 15,0 L | N50100016 | 15000 | 50 - 100 | 86.0 |
| TBL 20,0 S | N50100017 | 20000 | 0 - 65 | 123.0 |
| TBL 20,0 L | N50100018 | 20000 | 65 - 130 | 135.0 |
| TBL 30,0 S | N50100019 | 30000 | 0 - 65 | 195.0 |
| TBL 30,0 L | N50100020 | 30000 | 65 - 130 | 256.0 |

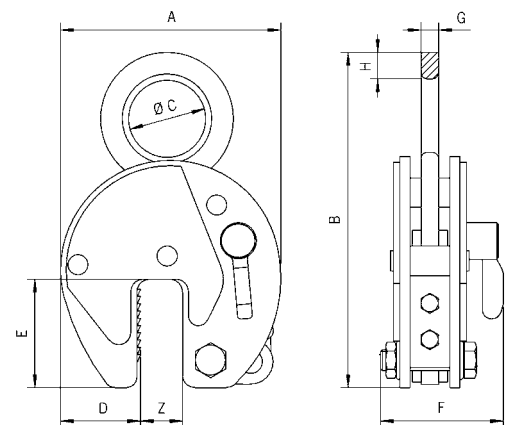

Dimensions TBL

| Model | TBL 4,0 S | TBL 4,0 L | TBL 6,0 S | TBL 6,0 L | TBL 8,0 S | TBL 8,0 L | TBL 10,0 S | TBL 10,0 L | TBL 15,0 S | TBL 15,0 L | TBL 20,0 S | TBL 20,0 L | TBL 30,0 S | TBL 30,0 L |
|---------|-----------|-----------|-----------|-----------|-----------|-----------|------------|------------|------------|------------|------------|------------|------------|------------|
| A, mm | 197 | 228 | 293 | 362 | 293 | 362 | 293 | 362 | 360 | 460 | 462 | 560 | 462 | 560 |
| B, mm | 339 | 339 | 442 | 482 | 450 | 482 | 503 | 503 | 550 | 615 | 674 | 724 | 667 | 732 |
| Ø C, mm | 80 | 80 | 89 | 89 | 89 | 89 | 110 | 110 | 130 | 130 | 130 | 130 | 60 | 60 |
| D, mm | 68 | 68 | 95 | 114 | 95 | 114 | 95 | 114 | 125 | 175 | 165 | 195 | 165 | 195 |
| E, mm | 93 | 100 | 143 | 143 | 143 | 143 | 143 | 143 | 162 | 162 | 210 | 210 | 210 | 210 |
| F, mm | 110 | 110 | 129 | 129 | 129 | 129 | 139 | 139 | 204 | 204 | 235 | 235 | 295 | 295 |
| G, mm | 20 | 20 | 20 | 20 | 20 | 20 | 25 | 25 | 45 | 45 | 45 | 45 | 65 | 65 |
| H, mm | 32 | 32 | 35 | 35 | 42 | 42 | 45 | 45 | 55 | 55 | 65 | 65 | 66 | 67 |



**TBS plus
Plate clamp
with hinged hook ring and
safety lock**

Capacity 1000 - 3000 kg

The TBS plate clamp with hinged hook ring can be used for the safe handling of plates at various angles. It can lift plates from the horizontal and put down in the vertical or alternatively lift it over the edge by gripping it from the side. The hinged hook ring ensures adequate clamping force in every position. Depending on the angle of usage capacity restrictions have to be taken into account, as shown in the diagram below.

The hinged hook ring has the added advantage of providing enough clamping force to hold a plate safely. Even when transporting large-sized plates with the 2-legged lifting system slipping of the load and damage to the clamp is avoided.

In addition to transporting plates, this clamp is suitable for turning steel structures and welded constructions.

INFO

The surface hardness of the material must not exceed HRC 30/Brinell 300.

The min. load is 10% of the nominal WLL!

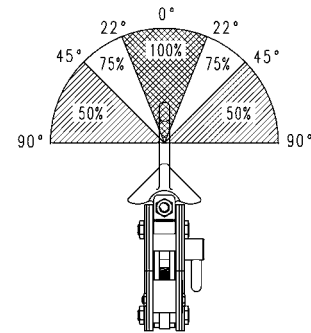

Technical data TBS plus

| Model | Art.-No. | Capacity kg | Jaw capacity Z mm | Weight kg |
|--------------|-----------|-------------|-------------------|-----------|
| TBS 1,0 plus | N50200312 | 1000 | 0 - 20 | 3.2 |
| TBS 2,0 plus | N50200313 | 2000 | 0 - 32 | 9.4 |
| TBS 3,0 plus | N50200314 | 3000 | 0 - 32 | 9.4 |

Dimensions TBS plus

| Model | TBS 1,0 plus | TBS 2,0 plus | TBS 3,0 plus |
|---------|--------------|--------------|--------------|
| A, mm | 126 | 192 | 192 |
| B, mm | 270 | 382 | 382 |
| Ø C, mm | 50 | 80 | 80 |
| D, mm | 49 | 75 | 75 |
| E, mm | 70 | 96 | 96 |
| F, mm | 95 | 132 | 132 |
| G, mm | 63 | 92 | 92 |
| H, mm | 12 | 20 | 20 |
| I, mm | 23 | 30 | 30 |

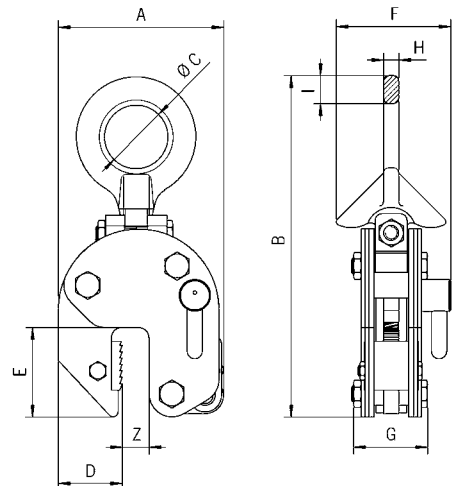

TBS
Plate clamp
with pivoting shackle and
safety lock

Capacity 4500 - 10000 kg



INFO

The surface hardness of the material must not exceed HRC 30/Brinell 300.

The min. load is 10% of the nominal WLL!

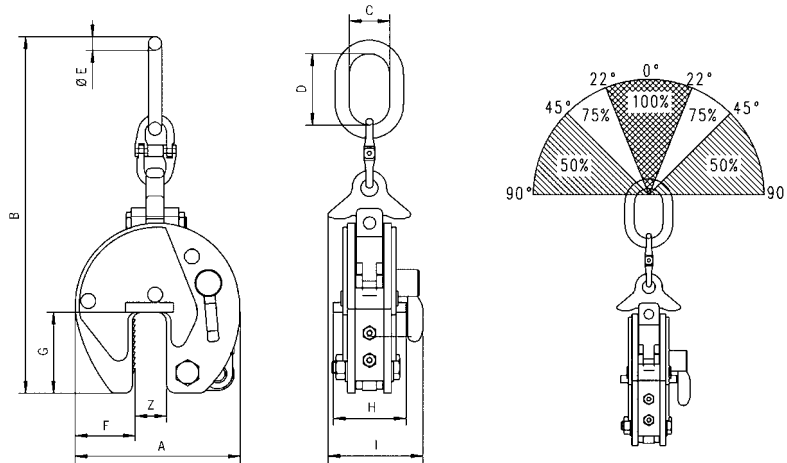

Technical data TBS

| Model | Art.-No. | Capacity kg | Jaw capacity Z mm | Weight kg |
|------------|-----------|-------------|-------------------|-----------|
| TBS 4,5 | N50200309 | 4500 | 0 - 50 | 34.4 |
| TBS 6,0 S | N50200305 | 6000 | 0 - 50 | 38.0 |
| TBS 6,0 L | N50200306 | 6000 | 50 - 100 | 42.0 |
| TBS 8,0 S | N50200307 | 8000 | 0 - 50 | 39.0 |
| TBS 8,0 L | N50200310 | 8000 | 50 - 100 | 42.4 |
| TBS 10,0 S | N50200308 | 10000 | 0 - 50 | 68.0 |
| TBS 10,0 L | N50200311 | 10000 | 50 - 100 | 80.0 |

Dimensions TBS

| Model | TBS 4,5 | TBS 6,0 S | TBS 6,0 L | TBS 8,0 S | TBS 8,0 L | TBS 10,0 S | TBS 10,0 L |
|---------|---------|-----------|-----------|-----------|-----------|------------|------------|
| A, mm | 292 | 292 | 367 | 292 | 367 | 360 | 446 |
| B, mm | 675 | 737 | 785 | 737 | 785 | 903 | 921 |
| C, mm | 95 | 95 | 98 | 98 | 98 | 110 | 112 |
| D, mm | 180 | 176 | 180 | 176 | 180 | 195 | 195 |
| Ø E, mm | 27.8 | 27.8 | 27.8 | 27.8 | 27.8 | 33 | 33 |
| F, mm | 95 | 95 | 115 | 95 | 115 | 125 | 168 |
| G, mm | 143 | 143 | 143 | 143 | 143 | 162 | 162 |
| H, mm | 135 | 137 | 135 | 136 | 136 | 170 | 170 |
| I, mm | 185 | 188 | 188 | 210 | 210 | 223 | 223 |



TAG Universal grab

Capacity 350 - 5000 kg

TWG -with modified side plates

Capacity 750 - 1250 kg

The universal grabs TAG and TWG save time, as it does not require chains, cables etc. when hoisting and loading material.

The large jaw capacity allows to tackle a variety of sizes with only one clamp. It can be used for loading machine tools, lifting steel constructions, welding and assembly jobs as well as for concrete and prefabricated pieces.

The universal grab with a small outside measurement is a specially designed grab for use on hard to reach places (e.g. lathe machine).

Features

- The automatic clamping force is retained by a positive tension spring, even if there is slack in the chain.
- The "Quick-Open" type universal grab opens by lifting and simultaneously pulling the lever out against the tension spring. The jaw is closed by the spring.
- Universal grabs up to 2.0t capacity are equipped with round chains, clamps with increased capacities are delivered with roller chains.

Option

- Model TAG up to 1.25t WLL is available with protective lining on the clamping jaws on request. This results in a decrease of the jaw capacity by 10 mm.

INFO

The surface hardness of the material must not exceed HRC 30/Brinell 300.

The min. load is 10% of the nominal WLL!



TWG with modified side plates for use in confined spaces (e.g. lathe machine).

Technical data TAG

| Model | Art.-No. | Capacity kg | Jaw width mm | Jaw capacity mm | Weight kg |
|--------------|-----------|-------------|--------------|-----------------|-----------|
| TAG 0,35/100 | N50300801 | 350 | 100 | 0 - 100 | 8.7 |
| TAG 0,35/200 | N50300802 | 350 | 200 | 90 - 200 | 16.3 |
| TAG 0,75/100 | N50300803 | 750 | 100 | 0 - 100 | 8.6 |
| TAG 0,75/200 | N50300804 | 750 | 200 | 90 - 200 | 16.6 |
| TAG 1,25/100 | N50300805 | 1250 | 100 | 0 - 100 | 14.9 |
| TAG 1,25/200 | N50300806 | 1250 | 200 | 90 - 200 | 24.3 |
| TAG 2,0/100 | N50300807 | 2000 | 100 | 0 - 100 | 20.8 |
| TAG 2,0/200 | N50300808 | 2000 | 200 | 90 - 200 | 29.1 |
| TAG 3,0/90 | N50300809 | 3000 | 90 | 5 - 90 | 26.5 |
| TAG 5,0/90 | N50300810 | 5000 | 90 | 5 - 90 | 30.5 |
| TAG 5,0/170 | N50300811 | 5000 | 170 | 80 - 170 | 43.8 |

Technical data TWG

| Model | Art.-No. | Capacity kg | Jaw width mm | Jaw capacity mm | Weight kg |
|--------------|-----------|-------------|--------------|-----------------|-----------|
| TWG 0,75/100 | N50300821 | 750 | 100 | 30 - 100 | 11.0 |
| TWG 1,25/100 | N50300822 | 1250 | 100 | 30 - 100 | 16.0 |

Dimensions TAG

| Model | TAG 0,35/100 | TAG 0,35/200 | TAG 0,75/100 | TAG 0,75/200 | TAG 1,25/100 | TAG 1,25/200 | TAG 2,0/100 | TAG 2,0/200 | TAG 3,0/90 | TAG 5,0/90 | TAG 5,0/170 |
|-------|--------------|--------------|--------------|--------------|--------------|--------------|-------------|-------------|------------|------------|-------------|
| A, mm | 264 | 382 | 264 | 382 | 320 | 382 | 328 | 375 | 297 | 297 | 354 |
| B, mm | 259 | 434 | 259 | 434 | 289 | 434 | 415 | 515 | 290 | 290 | 423 |
| C, mm | 128 | 195 | 128 | 195 | 128 | 195 | 135 | 195 | 136 | 136 | 180 |
| D, mm | 100 | 156 | 100 | 156 | 100 | 156 | 115 | 165 | 106 | 106 | 155 |
| E, mm | 100 | 200 | 100 | 200 | 100 | 200 | 100 | 200 | 90 | 90 | 170 |
| F, mm | 85 | 120 | 85 | 120 | 85 | 120 | 105 | 160 | 91 | 91 | 118 |
| G, mm | 550 | 760 | 550 | 760 | 570 | 760 | 571 | 750 | 570 | 570 | 620 |
| H, mm | 75 | 75 | 75 | 75 | 75 | 75 | 75 | 75 | 82 | 82 | 82 |
| I, mm | 121 | 121 | 121 | 121 | 121 | 121 | 121 | 121 | 111 | 111 | 111 |
| J, mm | 20 | 20 | 20 | 20 | 20 | 20 | 20 | 20 | 32 | 32 | 32 |
| K, mm | 78 | 90 | 83 | 90 | 83 | 90 | 105 | 105 | 137 | 147 | 147 |

Dimensions TWG

| Model | TWG 0,75/100 | TWG 1,25/100 |
|-------|--------------|--------------|
| A, mm | 264 | 320 |
| B, mm | 209 | 255 |
| C, mm | 128 | 128 |
| D, mm | 100 | 100 |
| E, mm | 100 | 100 |
| F, mm | 35 | 51 |
| G, mm | 550 | 570 |
| H, mm | 75 | 75 |
| I, mm | 121 | 121 |
| J, mm | 20 | 20 |
| K, mm | 83 | 83 |

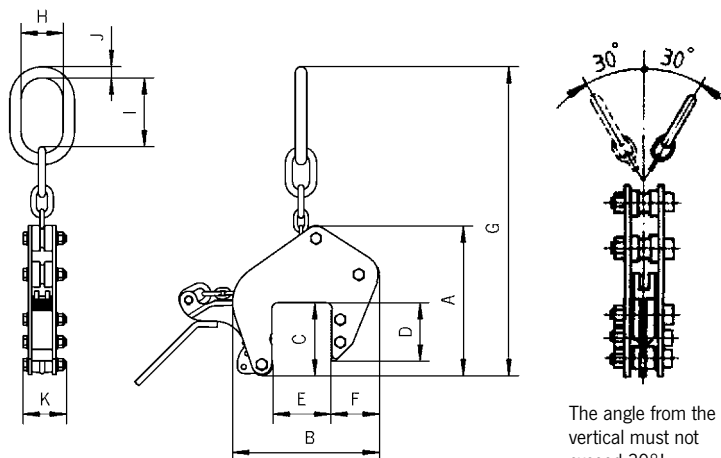

The angle from the vertical must not exceed 30°!

TIGRIP® T-MAG

Permanent load lifting magnet

Capacity

125 - 2000 kg (Flat material),
50 - 1000 kg (Round material)

The permanent lifting magnets of the T-MAG series are ideal for the simple, fast and therefore economical transport of heavy workpieces made of ferromagnetic material. The use of high-quality neodymium material enables a large lifting force with a low dead weight.

Both flat and round materials can be picked up. The load is not influenced mechanically. After switching off, there is only a small amount of residual magnetism.

Thanks to the simple Easy Switch operation, the lifting magnet can be switched over quickly and safely with just one hand. This reliable system enables not only safe and practical, but also faster work with up to 40% time savings.

When activated, the operating lever is locked by a safety lock so that unintentional demagnetization is prevented.

Features

- The simple "EASY SWITCH" enables one-hand operation.
- Extremely robust and compact design
- Easy to maintenance and service
- Low dead weight
- Low residual magnetism after switch-off
- High temperature range up to max. 80 °C
- Made in EU
- Safety factor 3:1 according to DIN EN 13155



"Easy Switch" ALLOWS SINGLE-HANDED OPERATION



INFO

The selection of the appropriate magnet model should be made under consideration of the varying conditions of the contact surface, kind of material alloy, ambient temperature and plate thickness.

For further information, please have a look into the manual.

DIVERSE POSSIBILITIES OF APPLICATION

The areas of application of this load handling device are very diverse and range from typical workshop applications to aligning tools in machining centers to rough use in steelworks, shipyards and even offshore.



Technical data T-MAG

| Model | Art.-No. | Flat material | | | Round material | | | Test load | Weight |
|------------|-----------|----------------------------|--|-------------------------|----------------------------|----------------------|-------------------------|-----------|--------|
| | | Capacity ¹ max. | Material thickness min. at max. capacity | Length of material max. | Capacity ¹ max. | Diameter min. - max. | Length of material max. | | |
| | | kg | mm | mm | kg | mm | mm | kg | kg |
| T-MAG 125 | 192047639 | 125 | 25 | 2500 | 65 | 50 - 100 | 2500 | 375 | 3 |
| T-MAG 250 | 192047640 | 250 | 30 | 3500 | 125 | 60 - 200 | 3500 | 750 | 10 |
| T-MAG 500 | 192047641 | 500 | 40 | 4000 | 250 | 65 - 270 | 4000 | 1500 | 21 |
| T-MAG 1000 | 192047642 | 1000 | 60 | 4500 | 500 | 100 - 300 | 4500 | 3000 | 40 |
| T-MAG 2000 | 192047643 | 2000 | 80 | 5000 | 1000 | 150 - 350 | 5000 | 6000 | 90 |

¹ Measured on bright drawn material S235JR (ST37), air gap <0,1 mm

Dimensions T-MAG

| Model | T-MAG 125 | T-MAG 250 | T-MAG 500 | T-MAG 1000 | T-MAG 2000 |
|-------|-----------|-----------|-----------|------------|------------|
| A, mm | 93 | 152 | 246 | 306 | 478 |
| B, mm | 60 | 100 | 120 | 146 | 165 |
| C, mm | 120 | 180 | 180 | 236 | 273 |
| D, mm | 125 | 182 | 185 | 225 | 265 |

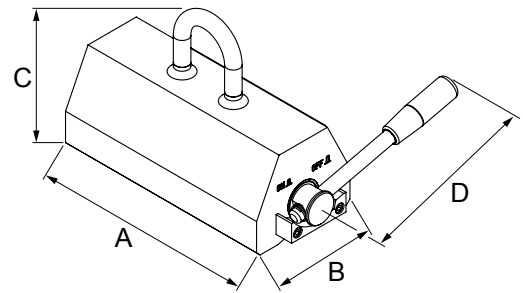

INFO

In order to achieve a maximum capacity, the contact surface should be bright and free from dirt, oil, grease, scale, corrosion, paint etc.





TPM

Permanent load lifting magnet

Capacity

100 - 3000 kg (Flat material)

50 - 1500 kg (Round material)

TPM load lifting magnets are ideal tools for easy, quick and thus economical transport of heavy objects made of ferro-magnetic material. Typical operating areas are workshops and warehouses, loading and unloading of machines as well as construction of jigs and fixtures.

Compact design of the units for a large number of applications.

The load is not affected mechanically which allows lifting of flat as well as round material. The efficient magnet body provides strong lifting capacity at low dead weight. The permanent magnets do not require electric energy and will leave only minor residual magnetism on the material after use.

The magnets are activated /deactivated easily by turning a locking lever. In activated condition the hand lever will be safely locked and thus prevent unintended demagnetising.

The selection of the appropriate magnet model should be made under consideration of the varying conditions of the contact surface, kind of material alloy and plate thickness /bar diameter (see table).

INFO

In order to achieve a maximum capacity, the contact surface should be bright and free from dirt, oil, grease, scale, corrosion, paint etc.



Technical data TPM

| Model | Art.-No. | Flat material | | | Capacity ¹ max. kg | Round material | | Test load kg | Weight kg |
|---------|-----------|-------------------------------------|---|-------------------------------------|-------------------------------------|-------------------------------|-------------------------------------|-----------------|--------------|
| | | Capacity ¹ max. kg | Material thickness min. at max. capacity mm | Length of material max. mm | | Diameter min. - max. mm | Length of material max. mm | | |
| TPM 0,1 | N56400001 | 100 | 14 | 2000 | 50 | 40 - 300 | 2000 | 300 | 5.3 |
| TPM 0,3 | N56400002 | 300 | 20 | 2500 | 150 | 60 - 300 | 2500 | 900 | 13.5 |
| TPM 0,5 | N56400003 | 500 | 24 | 3000 | 250 | 60 - 400 | 3000 | 1500 | 27.5 |
| TPM 0,8 | N56400004 | 800 | 34 | 3500 | 400 | 60 - 400 | 3500 | 2400 | 52.0 |
| TPM 1,0 | N56400005 | 1000 | 40 | 3500 | 500 | 80 - 400 | 3500 | 3000 | 57.0 |
| TPM 2,0 | N56400006 | 2000 | 55 | 3500 | 1000 | 100 - 400 | 3500 | 6000 | 125.0 |
| TPM 3,0 | 192019927 | 3000 | 65 | 3500 | 1500 | 200 - 500 | 3500 | 9000 | 195.0 |

¹ Measured on bright drawn material S235JR (ST 37), air gap <0,1 mm

Dimensions TPM

| Model | TPM 0,1 | TPM 0,3 | TPM 0,5 | TPM 0,8 | TPM 1,0 | TPM 2,0 | TPM 3,0 |
|-------|---------|---------|---------|---------|---------|---------|---------|
| A, mm | 122 | 192 | 232 | 302 | 332 | 392 | 497 |
| B, mm | 69 | 95 | 120 | 154 | 154 | 196 | 220 |
| C, mm | 185 | 225 | 270 | 320 | 320 | 420 | 453 |
| D, mm | 160 | 250 | 250 | 450 | 450 | 450 | 600 |

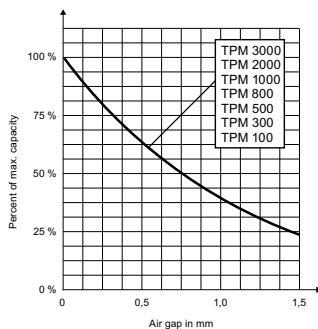

Diagram: WLL/air gap

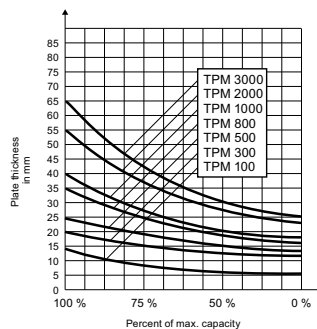
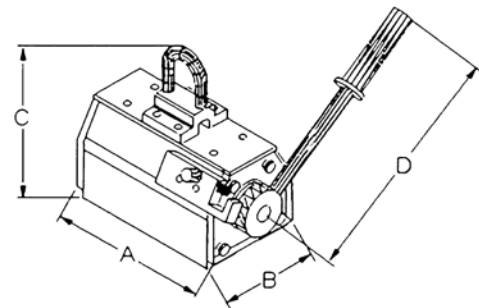
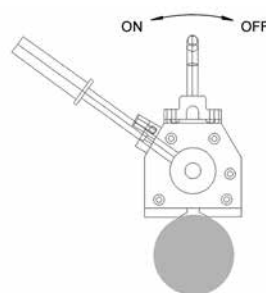
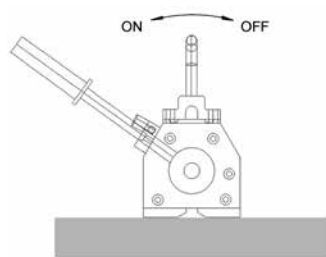

Diagram: WLL/material thickness



TPM



Correct use On/Off

| Reduction of capacity | % of capacity |
|-----------------------------|---------------|
| Temperature ≤ 60 °C | 100 % |
| Humidity ≤ 80 % | 100 % |
| St 52 | 95 % |
| Alloy steel | 80 % |
| High carbon steel | 70 % |
| Cast iron | 45 % |
| Nickel | 10 % |
| Austenitic, stainless steel | 0 % |
| Brass | 0 % |
| Aluminium | 0 % |





TBP

Non-marring grab

Capacity 500 - 1500 kg

The TBP non-marring grab is suitable for lifting, turning and transporting of plates with a sensitive surface without leaving behind indentations.

It can be used for aluminium and stainless steel plate or those with an extremely hard surface.

INFO

The surface of the plate must be free of oil, grease or any other liquid to ensure safe transport.

The min. load is 10% of the nominal WLL!

Temperature range from -20 °C up to +60 °C

Technical data TBP

| Model | Art.-No. | Capacity kg | Jaw capacity Z mm | Weight kg |
|---------|-----------|-------------|-------------------|-----------|
| TBP 0,5 | N51502419 | 500 | 0 - 10 | 3.0 |
| TBP 1,5 | N51502420 | 1500 | 0 - 20 | 12.6 |

Dimensions TBP

| Model | TBP 0,5 | TBP 1,5 |
|---------|---------|---------|
| A, mm | 127 | 215 |
| B, mm | 200 | 345 |
| D, mm | 52 | 75 |
| E, mm | 69 | 135 |
| F, mm | 87 | 131 |
| G, mm | 76 | 118 |
| H, mm | 13 | 20 |
| I, mm | 20 | 24 |
| Ø C, mm | 55 | 85 |

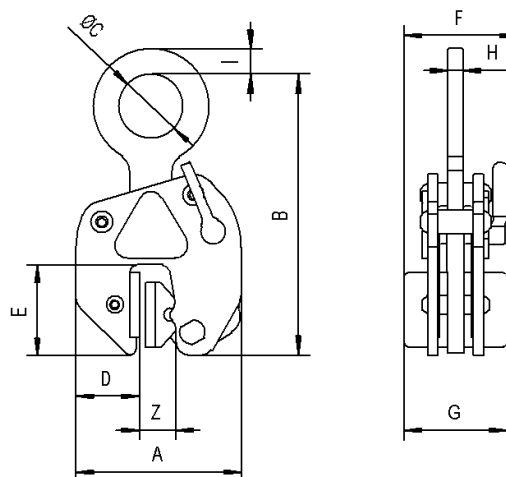

TSB Non-marring grab with chain

Capacity 750 - 1250 kg

The TSB grab has parallel-facing jaws that equally distribute the clamping pressure over a relatively large surface area. This makes the grab attractive for plate material with sensitive surfaces. The protective lining "Bremsit" offers an outstanding friction coefficient, thereby enhancing the grip of the jaws. This lining can be easily replaced when worn.

Similar to the universal grab, this grab has a large jaw capacity and the security of a safety lock device with a hold-open/hold-closed feature.

INFO

The surface of the plate must be free of oil, grease or any other liquid to ensure safe transport.

The min. load is 10% of the nominal WLL!

Temperature range from -20 °C up to +60 °C



Technical data TSB

| Model | Art.-No. | Capacity kg | Jaw capacity Z mm | Weight kg |
|-------------|-----------|-------------|-------------------|-----------|
| TSB 0,75/65 | N51202202 | 750 | 0 - 65 | 11.8 |
| TSB 1,25/65 | N51202203 | 1250 | 0 - 65 | 16.7 |

Dimensions TSB

| Model | TSB 0,75/65 | TSB 1,25/65 |
|-------|-------------|-------------|
| A, mm | 272 | 330 |
| B, mm | 260 | 280 |
| C, mm | 128 | 128 |
| D, mm | 100 | 100 |
| E, mm | 79 | 90 |
| F, mm | 78 | 90 |

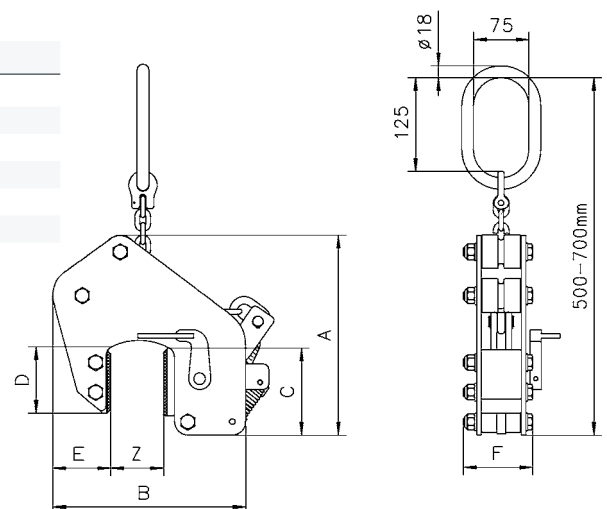



TTG Girder grab for horizontal transport

Capacity 500 - 7500 kg

The girder grab TTG is designed for the horizontal transport of girders, metal plates, profiles etc. The offset suspension lug ensures that the flange of the girder will be kept practically horizontal during transport.

The positive safety lock keeps the clamp safely locked, even before the lift begins. This allows the operator to place the clamp, lock it closed and move away from the load. The lever ensures easy opening and closing of the clamping jaw and has a "lock open" feature.

INFO

When transporting long girders, it is recommended to use a pair of clamps in conjunction with a spreader beam.

Technical data TTG

| Model | Art.-No. | Capacity kg | Jaw capacity mm | Weight kg |
|---------|-----------|----------------|--------------------|--------------|
| TTG 0,5 | N50901950 | 500 | 0 - 20 | 2.9 |
| TTG 1,5 | N50901951 | 1500 | 0 - 30 | 6.8 |
| TTG 3,0 | N50901952 | 3000 | 0 - 35 | 11.3 |
| TTG 4,5 | N50901953 | 4500 | 0 - 40 | 14.8 |
| TTG 7,5 | N50901954 | 7500 | 0 - 45 | 30.0 |

Dimensions TTG

| Model | TTG 0,5 | TTG 1,5 | TTG 3,0 | TTG 4,5 | TTG 7,5 |
|---------|---------|---------|---------|---------|---------|
| Ø A, mm | 50 | 70 | 80 | 90 | 110 |
| B, mm | 36 | 43 | 55 | 60 | 64 |
| C, mm | 25 | 35 | 42 | 46 | 55 |
| D, mm | 148 | 140 | 180 | 196 | 222 |
| E, mm | 200 | 180 | 214 | 248 | 304 |
| F, mm | 27 | 40 | 40 | 40 | 50 |
| G, mm | 20 | 30 | 32 | 35 | 42 |
| H, mm | 95 | 155 | 190 | 207 | 237 |
| I, mm | 110 | 230 | 284 | 314 | 367 |
| J, mm | 10 | 15 | 20 | 20 | 22 |
| K, mm | 56 | 50 | 60 | 64 | 90 |
| L, mm | 85 | 100 | 114 | 117 | 143 |
| M, mm | 13 | 16 | 20 | 25 | 30 |

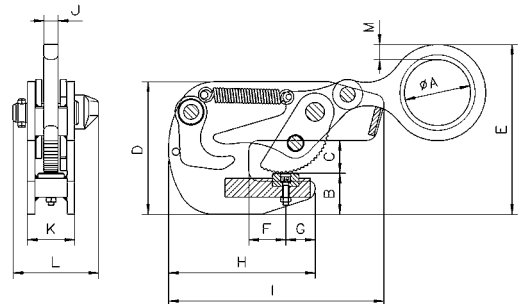

TTR Girder grab for vertical transport

Capacity 750 - 3000 kg

The girder grab TTR is designed for vertical transport, especially for lifting and stacking of girders. The unique position of the offset suspension lug keeps the girder virtually in a vertical position during transport.

The positive safety lock keeps the clamp safely locked, even before the lift begins. This allows the operator to place the clamp, lock it closed and move away from the load. The lever ensures easy opening and closing of the clamping jaw and has a "lock open" feature.



INFO

When transporting long girders, it is recommended to use a pair of clamps in conjunction with a spreader beam.

Technical data TTR

| Model | Art.-No. | Capacity kg | Jaw capacity mm | Weight kg |
|----------|-----------|-------------|-----------------|-----------|
| TTR 0,75 | N51702551 | 750 | 5 - 16 | 3.1 |
| TTR 1,50 | N51702552 | 1500 | 5 - 25 | 6.8 |
| TTR 3,00 | N51702553 | 3000 | 5 - 28 | 10.9 |

Dimensions TTR

| Model | TTR 0,75 | TTR 1,50 | TTR 3,00 |
|---------|----------|----------|----------|
| A, mm | 24 | 33 | 37 |
| B, mm | 40 | 53 | 56 |
| C, mm | 132 | 176 | 194 |
| D, mm | 62 | 76 | 78 |
| E, mm | 145 | 190 | 208 |
| F, mm | 118 | 152 | 163 |
| Ø G, mm | 50 | 70 | 80 |
| H, mm | 12 | 15 | 20 |
| I, mm | 12 | 17 | 23 |
| K, mm | 53 | 69 | 85 |

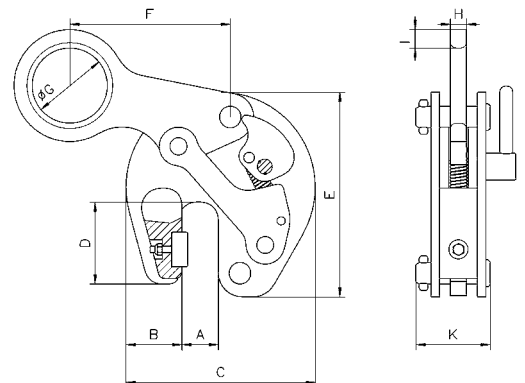



TTT Girder grab for horizontal transport

Capacity 750 - 4500 kg

The girder grab TTT is used for the horizontal transport of steel girders. Due to the split fixed jaw, it can be positioned centrally on the end of the beam. The grab should only be used in pairs.

The safety lock with positive spring tension holds the grab in position on the end of the girder even without load tension.

The lever is used to engage and disengage the jaw and to keep it open.

INFO

The angle from the vertical must not exceed 30°!

Technical data TTT

| Model | Art.-No. | Capacity kg | Jaw capacity mm | Weight kg |
|----------|-----------|----------------|--------------------|--------------|
| TTT 0,75 | N54509121 | 750 | 0 - 20 | 3 |
| TTT 1,5 | N54509122 | 1500 | 0 - 35 | 6 |
| TTT 3,0 | N54509123 | 3000 | 0 - 40 | 10 |
| TTT 4,5 | N54509124 | 4500 | 0 - 45 | 16 |

Dimensions TTT

| Model | TTT 0,75 | TTT 1,5 | TTT 3,0 | TTT 4,5 |
|---------|----------|---------|---------|---------|
| A, mm | 30 | 38 | 50 | 60 |
| B, mm | 70 | 70 | 75 | 90 |
| C, mm | 100 | 155 | 195 | 222 |
| D, mm | 142 | 150 | 195 | 222 |
| Ø E, mm | 50 | 70 | 80 | 90 |
| F, mm | 16 | 19 | 19 | 22 |
| G, mm | 16 | 20 | 25 | 30 |
| H, mm | 225 | 335 | 400 | 450 |
| I, mm | 45 | 45 | 80 | 90 |
| J, mm | 200 | 210 | 214 | 248 |
| K, mm | 106 | 120 | 125 | 147 |
| L, mm | 52 | 66 | 80 | 88 |

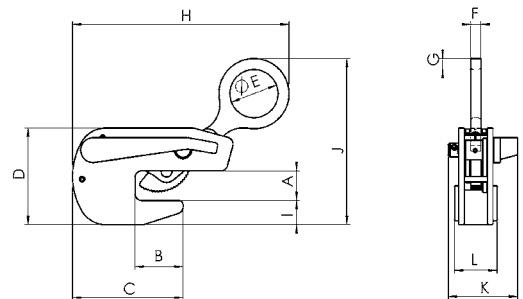

TCH Horizontal lifting gear

Capacity 1000 - 20000 kg

The TCH lifting clamp is designed to be used as a pair with a two-legged chain sling.

It is especially suited for the transport of single plates with a minimum thickness of approx. 5 mm as well as for plate bundles. The two-legged version is appropriate for normal sized plates.

For extra large or long plates, it is recommended to use two sets of the two-legged lifting gears in conjunction with a spreader beam. In the standard version, the lifting clamp is suitable for plates up to 1500 mm width. Lifting gears with longer chains for larger plate widths are available on request.



Similar image

INFO

The angle from the vertical must not exceed 45°!

The capacity applies to a pair of lifting clamps.

Technical data TCH

| Model | Art.-No. single clamp | Capacity ¹ kg | Jaw capacity mm | Weight ² kg |
|------------|--------------------------|-----------------------------|--------------------|---------------------------|
| TCH 1,0 | N50501517 | 1000 | 0 - 50 | 13.0 |
| TCH 2,0 | N50501511 | 2000 | 5 - 32 | 17.7 |
| TCH 4,0 | N50501512 | 4000 | 5 - 50 | 31.0 |
| TCH 6,0 | N50501513 | 6000 | 5 - 75 | 69.0 |
| TCH 8,0 | N50501514 | 8000 | 5 - 75 | 72.0 |
| TCH 10,0/1 | N50501515 | 10000 | 5 - 100 | 93.8 |
| TCH 10,0/2 | N50501516 | 10000 | 50 - 150 | 108.6 |
| TCH 15,0/1 | N4300012878 | 15000 | 5 - 100 | 110 |
| TCH 15,0/2 | N4300012879 | 15000 | 50 - 150 | 123 |
| TCH 20,0/1 | N4300014489 | 20000 | 5 - 100 | 165 |
| TCH 20,0/2 | N4300014491 | 20000 | 50 - 150 | 172 |

¹ Per pair, up to an angle of 45° from the vertical

² Approx. weight for 2 single clamps with a chain length = 1 m

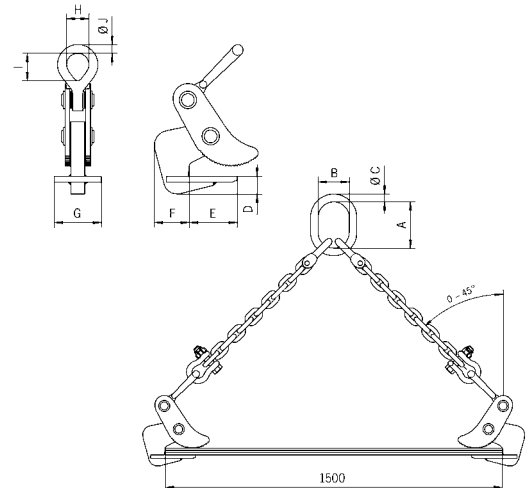

Dimensions TCH

| Model | TCH 1,0 | TCH 2,0 | TCH 4,0 | TCH 6,0 | TCH 8,0 | TCH 10,0/1 | TCH 10,0/2 | TCH 15,0/1 | TCH 15,0/2 | TCH 20,0/1 | TCH 20,0/2 |
|---------|---------|---------|---------|---------|---------|------------|------------|------------|------------|------------|------------|
| A, mm | 135 | 160 | 180 | 200 | 260 | 300 | 300 | - | - | - | - |
| B, mm | 75 | 90 | 100 | 110 | 140 | 160 | 160 | - | - | - | - |
| Ø C, mm | 18 | 22 | 26 | 32 | 36 | 40 | 40 | - | - | - | - |
| D, mm | 15 | 32 | 44 | 58 | 56 | 70 | 66 | 71 | 71 | 70 | 70 |
| E, mm | 82 | 83 | 114 | 172 | 170 | 216 | 218 | 230 | 230 | 220 | 220 |
| F, mm | 65 | 61 | 75 | 97 | 100 | 116 | 116 | 120 | 120 | 118 | 118 |
| G, mm | 100 | 100 | 99 | 129 | 128 | 149 | 150 | 150 | 150 | 220 | 220 |
| H, mm | 32 | 49 | 62 | 90 | 90 | 113 | 113 | 144 | 144 | 80 | 80 |
| I, mm | 44 | 72 | 89 | 127 | 130 | 113 | 113 | 144 | 144 | 120 | 120 |
| Ø J, mm | 13 | 19 | 26 | 36 | 37 | 50 | 50 | 50 | 50 | 60 | 60 |



TGF Horizontal lifting gear

Capacity 1300 - 10000 kg

The TGF horizontal lifting gear consists of two clamps with a two-legged chain sling and is especially suited for the transport of plate bundles.

The clamps are easily adjusted to the height of the plate by a special ratcheting lever.

The lifting clamps are available in special versions for bundle thicknesses up to 400 mm. The lifting gear is made according to your requirements

INFO

The angle from the vertical must not exceed 45°!

The capacity applies to a pair of lifting clamps.

Technical data TGF

| Model | Art.-No. single clamp | Capacity ¹ kg | Jaw capacity Z mm | Weight ² kg |
|--------------|--------------------------|-----------------------------|-------------------------|---------------------------|
| TGF 1,3/150 | N50601617 | 1300 | 0 - 150 | 23 |
| TGF 3,3/150 | N50601619 | 3300 | 0 - 150 | 39 |
| TGF 6,6/150 | N50601621 | 6650 | 0 - 150 | 65 |
| TGF 1,3/250 | N50601624 | 1300 | 0 - 250 | 23 |
| TGF 3,3/250 | N50601626 | 3300 | 0 - 250 | 39 |
| TGF 6,6/250 | N50601628 | 6650 | 0 - 250 | 87 |
| TGF 10,0/300 | 192065646 | 10000 | 0 - 300 | 92 |

¹ Per pair, up to an angle of 45° from the vertical

² Approx. weight for 2 single clamps with a chain length = 1 m

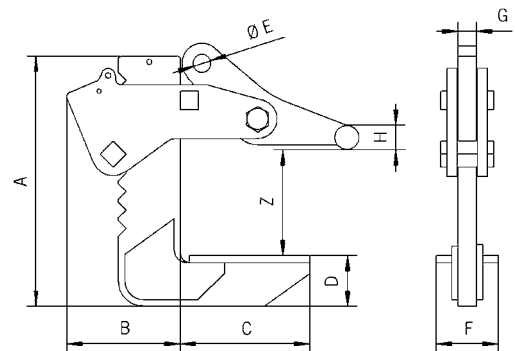

Dimensions TGF

| Model | TGF 1,3/150 | TGF 3,3/150 | TGF 6,6/150 | TGF 1,3/250 | TGF 3,3/250 | TGF 6,6/250 | TGF 10,0/300 |
|---------|-------------|-------------|-------------|-------------|-------------|-------------|--------------|
| A, mm | 298 | 321 | 405 | 448 | 417 | 495 | 495 |
| B, mm | 122 | 130 | 185 | 122 | 130 | 185 | 210 |
| C, mm | 160 | 160 | 210 | 140 | 160 | 210 | 240 |
| D, mm | 41 | 50 | 82 | 41 | 60 | 82 | 100 |
| Ø E, mm | 20 | 23 | 30 | 20 | 23 | 30 | 40 |
| F, mm | 80 | 80 | 100 | 80 | 80 | 100 | 120 |
| G, mm | 20 | 25 | 30 | 20 | 25 | 30 | 50 |
| Ø H, mm | 25 | 25 | 40 | 25 | 25 | 40 | 40 |

BVH Horizontal lifting hook

Capacity 500 - 7500 kg

The BVH horizontal lifting hooks are used in pairs with chain or wire rope slings to lift plate bundles that are relatively close to the ground.

The high tensile hooks have a serrated lifting surface.



INFO

The angle from the vertical must be 30 - 45°!

The chain has to be in line with the crank of the lifting hooks.

Technical data BVH

| Model | Art.-No. | Capacity ¹ kg | Weight kg |
|----------|-----------|-----------------------------|--------------|
| BVH 0,5 | N50500001 | 500 | 1.2 |
| BVH 1,12 | N50500002 | 1120 | 1.4 |
| BVH 1,5 | N50500003 | 1500 | 2.4 |
| BVH 2,0 | N50500004 | 2000 | 3.9 |
| BVH 2,5 | N50500005 | 2500 | 8.2 |
| BVH 3,2 | N50500006 | 3200 | 8.3 |
| BVH 4,0 | N50500007 | 4000 | 13.6 |
| BVH 5,3 | N50500008 | 5300 | 21.0 |
| BVH 6,0 | N50500009 | 6000 | 39.0 |
| BVH 7,5 | N50500010 | 7500 | 60.0 |

¹ Pro Stück

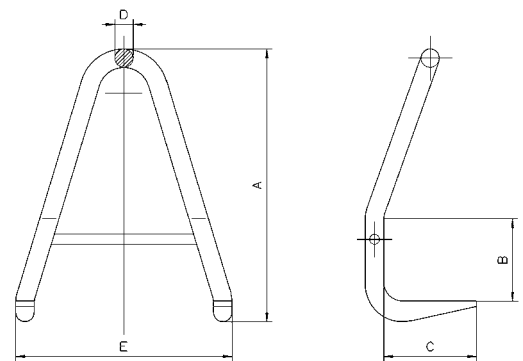

Dimensions BVH

| Model | BVH 0,5 | BVH 1,12 | BVH 1,5 | BVH 2,0 | BVH 2,5 | BVH 3,2 | BVH 4,0 | BVH 5,3 | BVH 6,0 | BVH 7,5 |
|-------|---------|----------|---------|---------|---------|---------|---------|---------|---------|---------|
| A, mm | 180 | 210 | 240 | 280 | 340 | 400 | 530 | 660 | 800 | 980 |
| B, mm | 50 | 60 | 70 | 80 | 100 | 120 | 160 | 200 | 250 | 300 |
| C, mm | 80 | 95 | 105 | 115 | 120 | 140 | 180 | 210 | 250 | 300 |
| D, mm | 18 | 20 | 22 | 26 | 32 | 32 | 36 | 40 | 50 | 60 |
| E, mm | 150 | 170 | 200 | 220 | 270 | 320 | 420 | 520 | 640 | 760 |



THS Lifting clamp with safety lock

Capacity 750 - 4500 kg

The THS lifting clamp is normally used in pairs especially for the horizontal transport of plates. The transport of slightly sagging plates is also possible. Individually, it can be used to load presses shears, and other machines. The safety lock is preventing the clamp from opening, even when there is no load. The jaws can be opened and closed with the safety lock lever. This clamp has a lock-open feature.

Option

- THS 1.5 and THS 3.0 are available with a hinged hook ring on request.

INFO

When used in pairs the angle from the vertical must not exceed 30°!



Technical data THS

| Model | Art.-No. | Capacity ¹ kg | Jaw capacity mm | Weight kg |
|----------|-----------|-----------------------------|--------------------|--------------|
| THS 0,75 | N50801851 | 750 | 0 - 20 | 3.2 |
| THS 1,5 | N50801852 | 1500 | 0 - 35 | 6.1 |
| THS 3,0 | N50801853 | 3000 | 0 - 40 | 12.7 |
| THS 4,5 | N50801854 | 4500 | 0 - 40 | 16.5 |

¹Per unit

Dimensions THS

| Model | THS 0,75 | THS 1,5 | THS 3,0 | THS 4,5 |
|---------|----------|---------|---------|---------|
| A, mm | 30 | 38 | 45 | 47 |
| B, mm | 70 | 80 | 95 | 110 |
| C, mm | 130 | 165 | 205 | 235 |
| D, mm | 97 | 120 | 160 | 196 |
| Ø E, mm | 50 | 70 | 80 | 90 |
| F, mm | 12 | 15 | 20 | 20 |
| G, mm | 15 | 17 | 25 | 30 |
| H, mm | 255 | 335 | 400 | 450 |
| I, mm | 15 | 20 | 30 | 59 |
| J, mm | 135 | 165 | 195 | 230 |
| K, mm | 80 | 90 | 100 | 110 |
| L, mm | 40 | 50 | 60 | 64 |

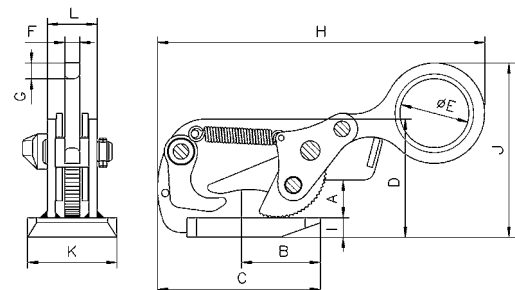

TWH Lifting clamp

Capacity 1500 - 5000 kg

The TWH lifting clamp, when used in pairs, is well-suited for horizontal transport of individual and bundled plates.

The clamp is not suited for thin plates that have a tendency to sag during transport.

It is normally used in combination with a two-legged chain sling.

The capacity (WLL) applies to a pair of lifting clamps.

Option

- Protective lining



INFO

The angle from the vertical must not exceed 45°!

Technical data TWH

| Model | Art.-No. | Capacity ¹ kg | Jaw capacity mm | Weight ² kg |
|---------------------|-----------|-----------------------------|--------------------|---------------------------|
| TWH 30 with roller | N54509101 | 1500 | 5 - 60 | 5.6 |
| TWH 50 with roller | N54509102 | 2500 | 10 - 70 | 10.3 |
| TWH 70 with roller | N54509103 | 3500 | 10 - 80 | 13.4 |
| TWH 100 with roller | N54509104 | 5000 | 10 - 102 | 27.7 |
| TWH 30 with plate | N54509105 | 1500 | 5 - 60 | 5.7 |
| TWH 70 with plate | N54509107 | 3500 | 10 - 80 | 13.5 |

¹Per pair, angle from the vertical max. 45° ²Per unit

Dimensions TWH

| Model | TWH 30 with roller | TWH 50 with roller | TWH 70 with roller | TWH 100 with roller | TWH 30 with plate | TWH 70 with plate |
|---------|-----------------------|-----------------------|-----------------------|------------------------|----------------------|----------------------|
| A, mm | 5 | 10 | 10 | 10 | 5 | 10 |
| B, mm | 60 | 70 | 80 | 102 | 60 | 80 |
| C, mm | 60 | 75 | 90 | 110 | 60 | 90 |
| D, mm | 105 | 130 | 162 | 170 | 105 | 162 |
| E, mm | 250 | 315 | 345 | 425 | 250 | 345 |
| F, mm | 200 | 275 | 292 | 345 | 200 | 292 |
| G, mm | 31 | 45 | 55 | 57 | 22 | 48 |
| H, mm | 30 | 30 | 30 | 45 | 30 | 30 |
| J, mm | 12 | 12 | 15 | 20 | 12 | 15 |
| K, mm | 50 | 64 | 64 | 89 | 50 | 64 |
| L, mm | 73 | 92 | 92 | 130 | 73 | 92 |
| Ø M, mm | 18 | 25 | 25 | 35 | 18 | 25 |
| N, mm | 36 | 58 | 65 | 80 | 36 | 65 |
| P, mm | 65 | 77 | 105 | 120 | 65 | 105 |
| R, mm | 120 | 150 | 185 | 210 | 120 | 185 |
| S, mm | 100 | 100 | 100 | 120 | 100 | 100 |
| T, mm | 10 | 10 | 10 | 12 | 10 | 10 |

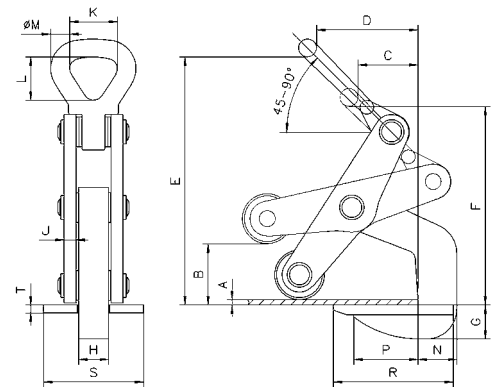

TWH with roller

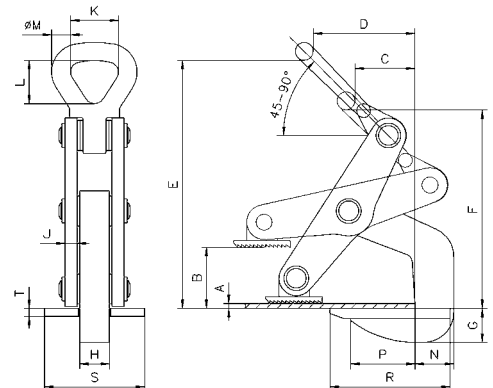

TWH with plate



THK Lifting clamp

Capacity 750 - 9000 kg

The THK lifting clamp, when used in pairs, is especially well-suited for horizontal transport of thin plates that have a tendency to sag.

It is normally used in combination with a two-legged chain sling.

The capacity applies to a pair of lifting clamps.



INFO

The angle from the vertical must not exceed 30°!

Technical data THK

| Model | Art.-No. | Capacity ¹ kg | Jaw capacity mm | Weight ² kg |
|----------|-----------|-----------------------------|--------------------|---------------------------|
| THK 0,75 | N50701751 | 750 | 0 - 25 | 1.7 |
| THK 1,5 | N50701752 | 1500 | 0 - 35 | 3.2 |
| THK 3,0 | N50701753 | 3000 | 0 - 35 | 5.7 |
| THK 4,5 | N50701754 | 4500 | 0 - 45 | 8.4 |
| THK 6,0 | N50701755 | 6000 | 0 - 60 | 11.6 |
| THK 9,0 | N50701756 | 9000 | 0 - 60 | 17.9 |

¹Per pair, angle from the vertical max. 30°

²Per unit

Dimensions THK

| Model | THK 0,75 | THK 1,5 | THK 3,0 | THK 4,5 | THK 6,0 | THK 9,0 |
|---------|----------|---------|---------|---------|---------|---------|
| A, mm | 25 | 36 | 38 | 48 | 63 | 65 |
| B, mm | 72 | 80 | 93 | 103 | 124 | 113 |
| C, mm | 118 | 135 | 168 | 183 | 214 | 223 |
| D, mm | 81 | 102 | 119 | 140 | 176 | 188 |
| Ø E, mm | 20 | 25 | 30 | 30 | 35 | 40 |
| F, mm | 161 | 198 | 227 | 238 | 284 | 317 |
| G, mm | 12 | 15 | 20 | 25 | 30 | 35 |
| H, mm | 86 | 102 | 110 | 122 | 110 | 148 |
| I, mm | 12 | 15 | 20 | 20 | 20 | 20 |

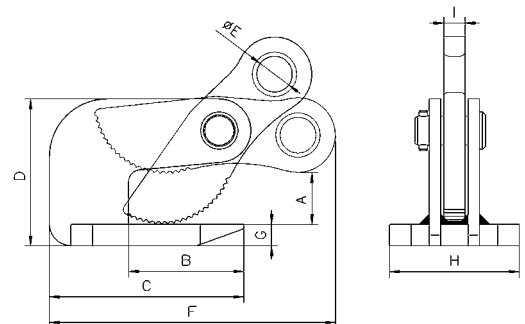

TPZ
Board clamp

Capacity 400 - 750 kg

The TPZ clamp is made for lifting and vertically transporting wood, particle board and plastic sheets.

The pliers are fastened to the plate with the aid of a hand-held lever. The jaw, which has a protective lining, grabs once lifting begins and holds the board securely.



Technical data TPZ

| Model | Art.-No. | Capacity kg | Jaw capacity Z mm | Weight kg |
|--------------|-----------|-------------|-------------------|-----------|
| TPZ 0,4/50 | N56200001 | 400 | 5 - 50 | 6.3 |
| TPZ 0,4/100 | N56200002 | 400 | 50 - 100 | 9.0 |
| TPZ 0,75/60 | N56200003 | 750 | 5 - 60 | 12.0 |
| TPZ 0,75/120 | N56200004 | 750 | 60 - 120 | 14.0 |

Dimensions TPZ

| Model | TPZ 0,4/50 | TPZ 0,4/100 | TPZ 0,75/60 | TPZ 0,75/120 |
|-------|------------|-------------|-------------|--------------|
| A, mm | 120 | 120 | 155 | 155 |
| B, mm | 290 | 335 | 349 | 406 |
| C, mm | 525 | 525 | 545 | 560 |
| D, mm | 125 | 125 | 145 | 145 |
| E, mm | 117 | 117 | 135 | 135 |
| F, mm | 60 | 60 | 121 | 121 |
| G, mm | 40 | 40 | 75 | 75 |
| H, mm | 6 | 6 | 8 x 24 | 8 x 24 |

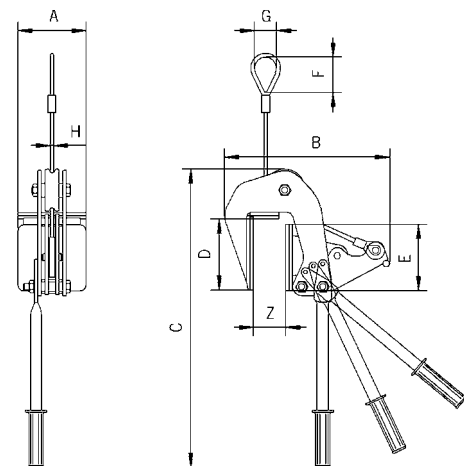

TPZ, up to 400 kg equipped with rope, from 750 kg equipped with chain.



THM Manual claw, magnetic

Capacity 120 - 170 kg

The THM manual magnetic claw is used for transporting steel sheets horizontally and vertically, lifting plates from racks, pulling steel sheets out of shelving, as well as transporting flat pieces of magnetizable steel.

The clamp, depending on the type, can be used for plate thicknesses from 1 to 5 mm.

Pressing down on the handle activates a cam which releases the magnetic claw from the workpiece.

This manual claw is maintenance-free and keeps the magnetic force for an unlimited period of time.

INFO

In order to achieve a maximum capacity, the contact surface should be bright and free from dirt, oil, grease, scale, corrosion, paint etc.

Technical data THM

| Model | Art.-No. | Capacity ¹ kg | Pulling capacity ¹ kg | Weight kg |
|---------|-----------|-----------------------------|-------------------------------------|--------------|
| THM 120 | N51602501 | 120 | 70 | 2 |
| THM 170 | N51602502 | 170 | 100 | 2 |

¹Measured at a safety factor 2:1 on bright drawn material St37 k

Dimensions THM

| Model | THM 120 | THM 170 |
|-------|---------|---------|
| A, mm | 116 | 116 |
| B, mm | 140 | 140 |
| C, mm | 130 | 130 |
| D, mm | 25 | 25 |
| E, mm | 172 | 172 |

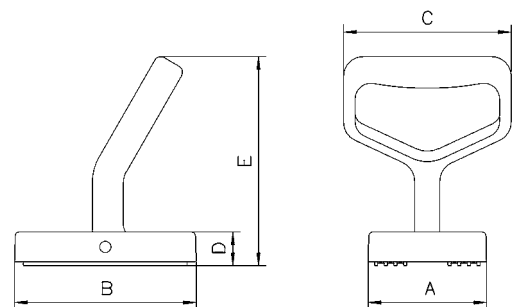

THG Hand clamp

Capacity 250 kg

The THG hand clamp is suited for the individual transport of light and thin plates. Pressing down on the hand grip releases the tension spring, allowing the clamp to open and slide onto the plate.

The plate can be transported by holding onto the ergonomically designed hand grip.

The positive spring pressure prevents the plate from accidental slipping out of the clamp.



INFO

The plate surface of the material must not exceed a hardness of HRC 30.

Technical data THG

| Model | Art.-No. | Capacity kg | Jaw capacity mm | Weight kg |
|---------------------|-------------|-------------|-----------------|-----------|
| THG | N51502415 | 250 | 0 - 10 | 1.4 |
| THG EX ¹ | N4300013269 | 250 | 0 - 10 | 1.5 |
| THG EB ² | N4300007661 | 250 | 0 - 10 | 1.4 |

¹ EX = Extended handle (300 mm)

² EB = Eye bolt (instead of handle)

Dimensions THG

| Model | THG | THG EX | THG EB |
|---------------|-----|--------|--------|
| A, mm | 184 | 280 | 610 |
| B, mm | 105 | 105 | 105 |
| C, mm | 12 | 12 | 12 |
| D, mm | 53 | 53 | 53 |
| Thickness, mm | 40 | 40 | 40 |

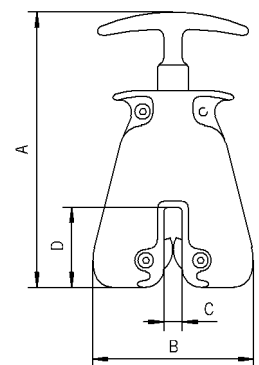

Attaching



Transport



TSH Screw clamp for vertical and horizontal pulling

Capacity 750 - 5000 kg

The screw clamp offers many possible applications. It is particularly useful for lifting, turning and pulling steel plates, girders and steel constructions.

The spindle is closed only finger tight.

Once the screw clamp is tightened and lifting begins, the pivoting pad clamping system produces a wedging action against the material, holding it securely (see below functional drawing).

Technical data TSH

| Model | Art.-No. | Capacity kg | Jaw capacity Z mm | Weight kg |
|-----------|-----------|-------------|-------------------|-----------|
| TSH 0,75 | N51502400 | 750 | 0 - 28 | 3.1 |
| TSH 1,5 | N51502401 | 1500 | 0 - 32 | 7.4 |
| TSH 2,0 | N51502422 | 2000 | 90 - 140 | 14.8 |
| TSH 2,0 S | N51502428 | 2000 | 50 - 100 | 14.5 |
| TSH 3,0 | N51502402 | 3000 | 0 - 50 | 11.4 |
| TSH 5,0 | N51502403 | 5000 | 0 - 80 | 27.6 |

Dimensions TSH

| Model | TSH 0,75 | TSH 1,5 | TSH 2,0 | TSH 2,0 S | TSH 3,0 | TSH 5,0 |
|---------|----------|---------|---------|-----------|---------|---------|
| A, mm | 190 | 255 | 318 | 318 | 290 | 470 |
| B, mm | 52 | 65 | 74 | 74 | 74 | 130 |
| Ø C, mm | 19 | 26 | 30 | 30 | 30 | 50 |
| D, mm | 43 | 75 | 90 | 90 | 85 | 135 |
| E, mm | 113 | 130 | 286 | 246 | 170 | 225 |
| F, mm | 35 | 44 | 60 | 60 | 50 | 72 |
| X, mm | 15 | 40 | 38 | 38 | 40 | 50 |

INFO

The plate surface of the material must not exceed a hardness level of HRC 50.

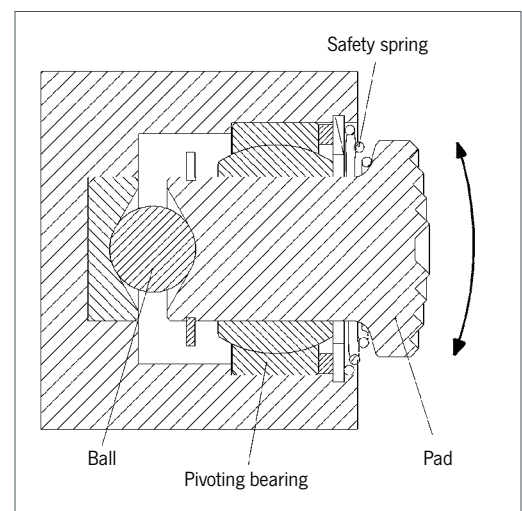
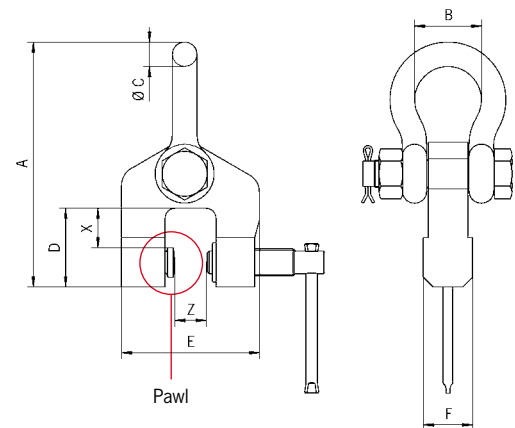

Functional drawing pivoting pad

TSZ Screw clamp for three-dimensional pulling

Capacity 500 - 7500 kg

The TSZ screw clamp is designed to pull in three directions. It offers many different possibilities for transporting steel constructions, feeding machining centres, etc.

The spindle is closed only finger tight.

When the screw clamp is tightened and lifting begins, the pivoting pad clamping system produces a wedging action against the material, holding it securely (see below functional drawing).



INFO

The plate surface of the material must not exceed a hardness level of HRC 50.

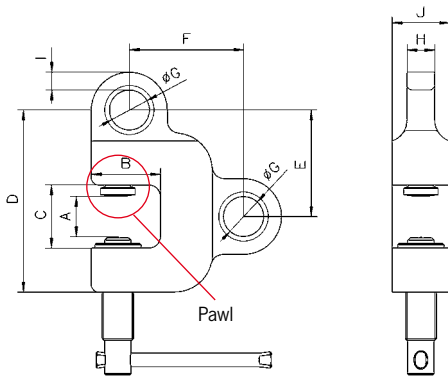

Technical data TSZ

| Model | Art.-No. | Capacity kg | Jaw capacity mm | Weight kg |
|---------|-----------|-------------|-----------------|-----------|
| TSZ 0,5 | N51502410 | 500 | 0 - 28 | 2.3 |
| TSZ 1,5 | N51502411 | 1500 | 0 - 35 | 5.6 |
| TSZ 3,0 | N51502412 | 3000 | 0 - 35 | 8.8 |
| TSZ 5,0 | N51502413 | 5000 | 0 - 40 | 16.2 |
| TSZ 7,5 | N51502414 | 7500 | 0 - 40 | 20.9 |

Dimensions TSZ

| Model | TSZ 0,5 | TSZ 1,5 | TSZ 3,0 | TSZ 5,0 | TSZ 7,5 |
|---------|---------|---------|---------|---------|---------|
| A, mm | 28 | 35 | 35 | 40 | 40 |
| B, mm | 43 | 60 | 67 | 85 | 92 |
| C, mm | 45 | 55 | 65 | 75 | 75 |
| D, mm | 125 | 158 | 195 | 230 | 240 |
| E, mm | 72 | 93 | 114 | 133 | 143 |
| F, mm | 83 | 99 | 120 | 150 | 162 |
| Ø G, mm | 26 | 35 | 46 | 55 | 65 |
| H, mm | 16 | 24 | 34 | 40 | 50 |
| I, mm | 12 | 16 | 17 | 18 | 23 |
| J, mm | 35 | 50 | 60 | 75 | 80 |

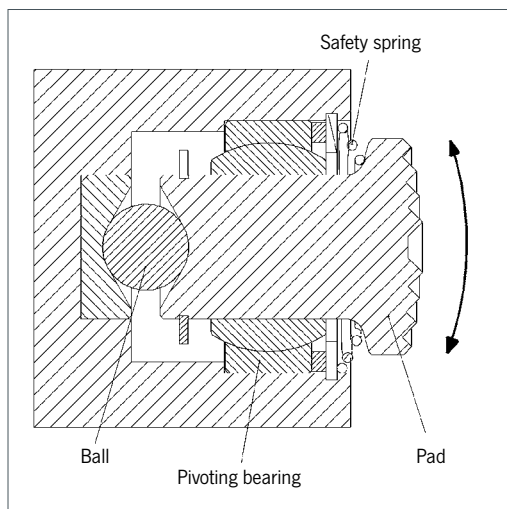

Functional drawing pivoting pad

TRU Roundstock grab

Capacity 100 - 4000 kg

The TRU roundstock grab picks up roundstock and pipe material up to 600 mm in diameter quickly and safely. With its optional protective lining, it can also pick up materials with sensitive surfaces.

INFO

When using protective lining, it is important that the surfaces are dry, clean and free of oil and grease.



Technical data TRU

| Model | Art.-No. | Art.-No. with protective lining | Capacity kg | Jaw capacity Z mm | Weight kg |
|-------------|-----------|------------------------------------|----------------|----------------------|--------------|
| TRU 0,1/150 | N51902711 | N51902712 | 100 | 50 - 150 | 4.2 |
| TRU 0,5/200 | N51902701 | N51902706 | 500 | 35 - 200 | 13.6 |
| TRU 1,0/200 | N51902702 | N51902707 | 1000 | 35 - 200 | 13.6 |
| TRU 1,5/300 | N51902703 | N51902708 | 1500 | 80 - 300 | 27.0 |
| TRU 3,0/300 | N51902704 | N51902709 | 3000 | 80 - 300 | 49.0 |
| TRU 4,0/600 | N51902705 | N51902710 | 4000 | 200 - 600 | 204.0 |

Dimensions TRU

| Model | TRU 0,1/150 | TRU 0,5/200 | TRU 1,0/200 | TRU 1,5/300 | TRU 3,0/300 | TRU 4,0/600 |
|------------|----------------|----------------|----------------|----------------|----------------|----------------|
| A, mm | 270 | 503 | 509 | 720 | 740 | 1420 |
| B min., mm | 292 | 417 | 437 | 520 | 582 | 930 |
| B max., mm | 458 | 723 | 745 | 937 | 960 | 1815 |
| C, mm | 97 | 150 | 178 | 204 | 220 | 318 |
| D, mm | 43 | 56 | 82 | 84 | 125 | 205 |
| E, mm | 8 | 15 | 15 | 20 | 20 | 30 |
| F, mm | 17 | 17 | 30 | 25 | 30 | 35 |

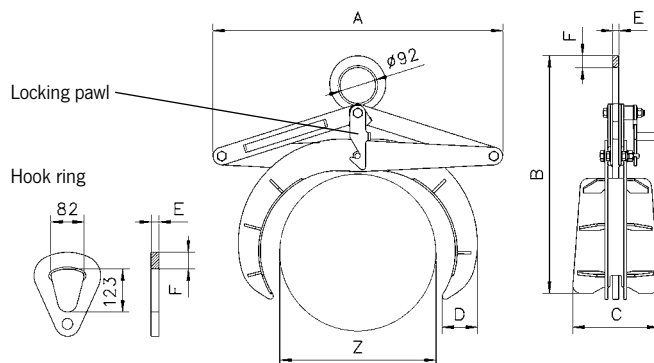

TRU, hook ring for grabs for 2000 kg and above.
Locking pawl keeps the grab in the open position.

TPR
Profile steel grab

Capacity 500 - 3000 kg

The TPR steel grab is designed for transport of girders, profile steel, etc. It boasts a large jaw capacity, which makes it useful for various flange widths.

The clamping jaws press securely with a positive fit to the girder.



Technical data TPR

| Model | Art.-No. | Capacity kg | Jaw capacity Z mm | Weight kg |
|-------------|-----------|-------------|-------------------|-----------|
| TPR 0,5/200 | N51802601 | 500 | 0 - 200 | 15.0 |
| TPR 1,5/300 | N51802602 | 1500 | 0 - 300 | 22.6 |
| TPR 3,0/300 | N51802603 | 3000 | 0 - 300 | 41.7 |

Dimensions TPR

| Model | TPR 0,5/200 | TPR 1,5/300 | TPR 3,0/300 |
|------------|-------------|-------------|-------------|
| A, mm | 510 | 710 | 720 |
| B min., mm | 390 | 495 | 525 |
| B max., mm | 625 | 830 | 920 |
| C, mm | 200 | 200 | 220 |
| D, mm | 15 | 15 | 20 |
| E, mm | 30 | 30 | 43 |

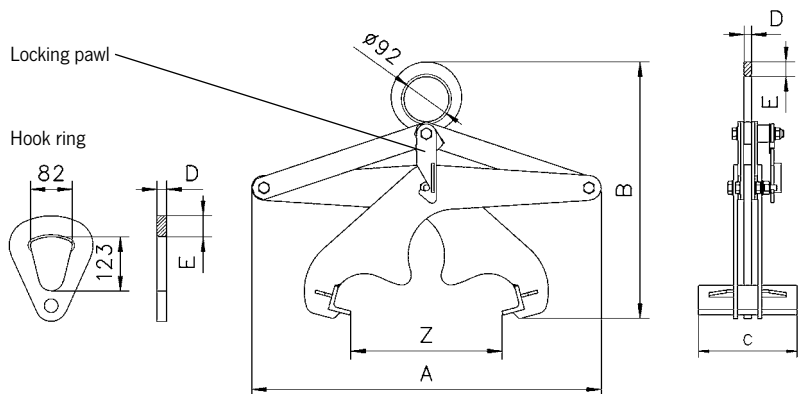

Hook ring for grabs for 2000 kg and above.
Locking pawl keeps the grab in the open position.



TVB Block grab

Capacity 250 and 500 kg

The TVB block grab is useful for the transport of stone and concrete blocks and other materials with parallel surfaces. The grab has a protective lining to ensure a safe and non-marring transport.

The clamping jaw and the center of gravity are easily and quickly adjustable by means of the locking pin.

INFO

It is important that the surfaces are dry, clean and free of oil and grease.

Technical data TVB

| Model | Art.-No. | Capacity kg | Jaw capacity Z mm | Weight kg |
|---------|-----------|-------------|-------------------|-----------|
| TVB 500 | N52625000 | 250/500 | 0 - 240 | 13 |

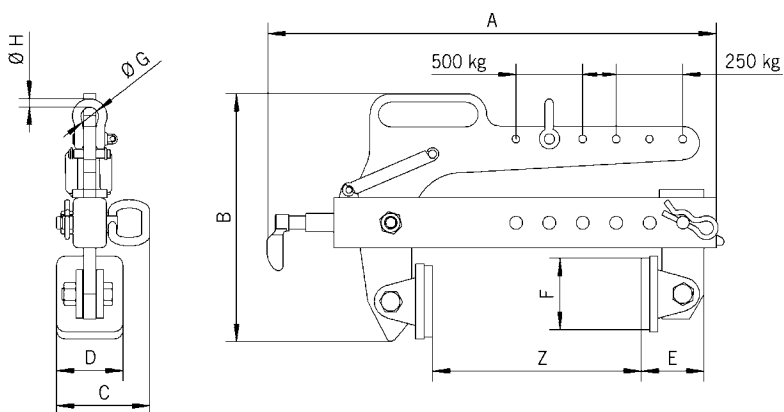

Dimensions TVB

| Model | TVB 500 |
|---------|---------|
| A, mm | 537 |
| B, mm | 296 |
| C, mm | 112 |
| D, mm | 80 |
| E, mm | 75 |
| F, mm | 85 |
| Ø G, mm | 22 |
| Ø H, mm | 10 |



TBG
Concrete grab

Capacity 500 - 1000 kg

The TBG block grabs are suited for the transport of all materials with parallel surfaces that can withstand a clamping pressure twice as high as the load being lifted.

The grabs are delivered with a replaceable hard rubber protective lining as standard.

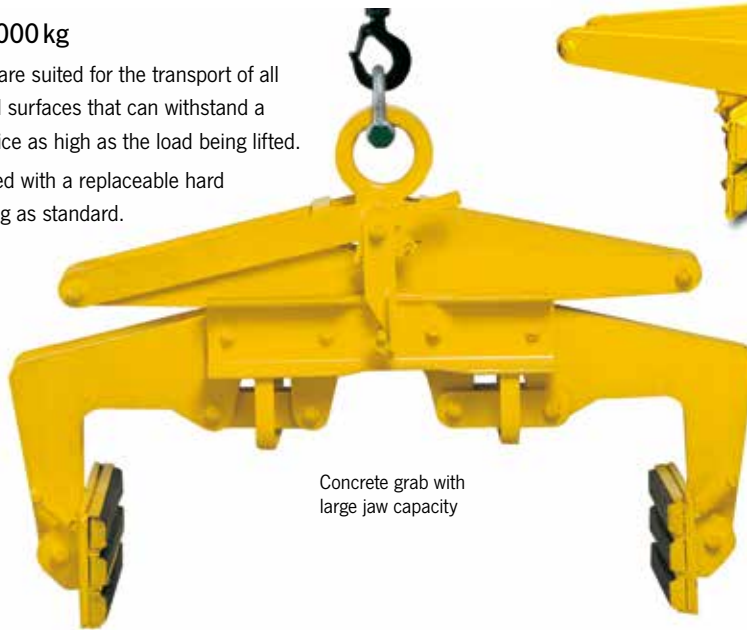

Concrete grab with large jaw capacity



Concrete grab with small jaw capacity



Technical data TBG with small and large jaw capacity

| Model | Art.-No. | Capacity kg | Jaw capacity Z mm | Weight kg |
|--------------|-----------|-------------|-------------------|-----------|
| TBG 0,5/150 | N52604009 | 500 | 0 - 150 | 27 |
| TBG 1,0/250 | N52604010 | 1000 | 50 - 250 | 50 |
| TBG 0,2/500 | N52604156 | 200 | 200 - 500 | 49 |
| TBG 0,3/700 | N52604157 | 300 | 400 - 700 | 52 |
| TBG 0,5/900 | N52604158 | 500 | 600 - 900 | 55 |
| TBG 1,0/400 | N52704251 | 1000 | 100 - 400 | 51 |
| TBG 1,0/1100 | N52604159 | 1000 | 800 - 1100 | 72 |

INFO

When using rubber protective lining it is important that the surfaces are dry, clean and free of oil and grease.

Dimensions TBG with small and large jaw capacity

| Model | TBG 0,5/150 | TBG 1,0/250 | TBG 0,2/500 | TBG 0,3/700 | TBG 0,5/900 | TBG 1,0/400 | TBG 1,0/1100 |
|---------------------|-------------|-------------|-------------|-------------|-------------|-------------|--------------|
| A ¹ , mm | 815 | 1050 | 1040 | 1040 | 1120 | 1040 | 1320 |
| B min., mm | 420 | 460 | 390 | 390 | 390 | 390 | 390 |
| B max., mm | 760 | 980 | 840 | 840 | 840 | 840 | 840 |
| C, mm | 200 | 250 | 275 | 275 | 275 | 250 | 275 |
| D, mm | 160 | 160 | 160 | 160 | 160 | 160 | 160 |
| E, mm | 30 | 29 | 300 | 300 | 300 | 300 | 300 |
| F, mm | 15 | 20 | 35 | 35 | 35 | 35 | 35 |
| G, mm | - | - | 20 | 20 | 20 | 20 | 20 |

¹ Scissor dimensions

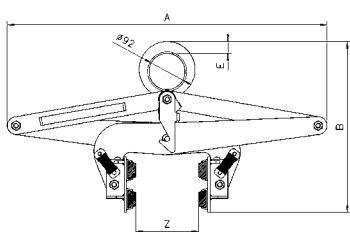

Concrete grab with small jaw capacity

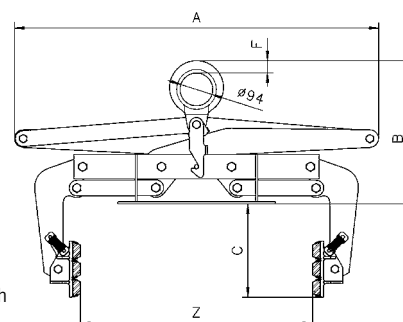
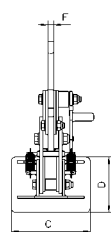

Concrete grab with large jaw capacity

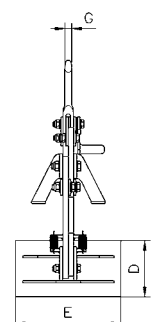



TBA Bale grab

Capacity 200 - 1000 kg

The TBA bale grab transports bales of fiber, wool, fabric, paper, pressed straw and various types of shavings up to a width of 1.3 m. Bales are gripped safely yet gently, and where applicable, the clamps are lined with a soft and pliable material.

The locking pawl only engages if the grab is opened without manual intervention.

INFO

The standard grab is equipped with protective linings.

Serrated jaws available on request.

Technical data TBA

| Model | Art.-No. with protective lining | Capacity kg | Jaw capacity Z mm | Weight kg |
|---------------|---------------------------------|-------------|-------------------|-----------|
| TBA 0,2/700 | N52804501 | 200 | 250 - 700 | 40 |
| TBA 0,3/900 | N52804502 | 300 | 450 - 900 | 42 |
| TBA 0,5/1100 | N52804503 | 500 | 650 - 1100 | 45 |
| TBA 0,75/1300 | N52804504 | 750 | 850 - 1300 | 62 |
| TBA 1,0/1300 | N52804505 | 1000 | 850 - 1300 | 62 |



Dimensions TBA

| Model | TBA 0,2/700 | TBA 0,3/900 | TBA 0,5/1100 | TBA 0,75/1300 | TBA 1,0/1300 |
|-------|-------------|-------------|--------------|---------------|--------------|
| A, mm | 890 | 1090 | 1290 | 1550 | 1550 |
| B, mm | 420 | 420 | 420 | 420 | 420 |
| C, mm | 500 | 500 | 500 | 500 | 500 |
| D, mm | 35 | 35 | 35 | 35 | 35 |
| E, mm | 20 | 20 | 20 | 20 | 20 |

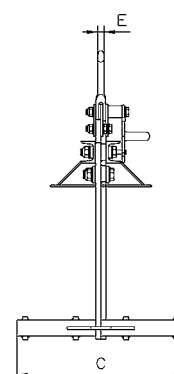
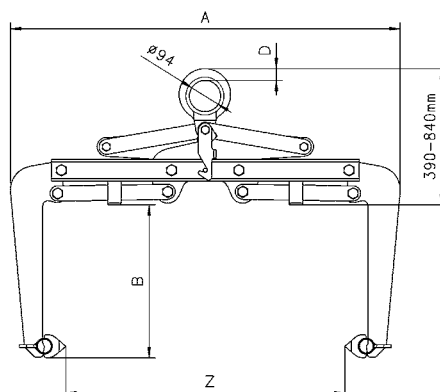

TBA 0.2-1t with serrated jaw

TCR

Rail grab with safety lock

Capacity 1000 - 2000 kg

The TCR rail grab transports rails, as used by railways, easily and safely. A safe grip is ensured by the lever operated safety lock. For long rails, two grabs must be attached to a spreader beam to avoid sagging.

Since the rails are primarily grabbed with positive fit, it is important that the clamp stays in a vertical position during initial lift.



Technical data TCR

| Model | Art.-No. | Capacity kg | Weight kg |
|---------|-----------|-------------|-----------|
| TCR 1,0 | N51402351 | 1000 | 12.4 |
| TCR 2,0 | N51402352 | 2000 | 13.9 |

Dimensions TCR

| Model | TCR 1,0 | TCR 2,0 |
|---------------------|---------|---------|
| A ¹ , mm | 144 | 144 |
| B, mm | 152 | 163 |
| C, mm | 350 | 350 |
| D, mm | 90 | 90 |
| E, mm | 46 | 46 |
| Ø F, mm | 20 | 20 |
| G, mm | 25 | 25 |

¹Scissor dimensions

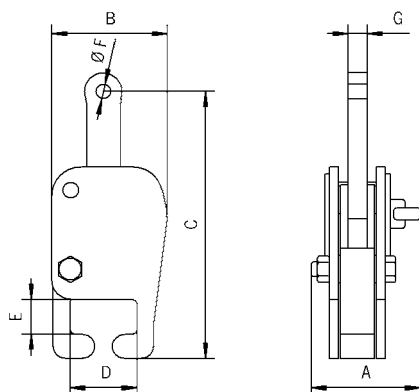

INFO

For special sizes please advise rail type and profile!

A TCR multiple rail system is also available for the simultaneous transport of up to 12 rails.

For rail jacks please see page 124.



TCU



TCO



Container lifting lug TCO

TCU and TCO Container lifting lugs

Capacity 32000 - 56000 kg

The lugs serve as flexible attachment points for the transport of containers. Two types are available which can be fastened to either the "top" or to the "bottom" of the container.

These container lifting lugs are offered in a set of 4 pieces.

TCO

Model TCO is vertically mounted in the hole at the top of the container. Turning the TCO 90°, locks it securely in place.

Transport is done with the use of a spreader beam in conjunction with wire rope, chain or textile slings making sure the load is suspended vertically.

TCU

Model TCU is laterlay mounted at the bottom fixing hole on the container and has a spring-loaded bolt to prevent an accidental release.

Technical data TCO and TCU

| Model | Art.-No. | Capacity ¹ kg | Weight ¹ kg | Sling angle from vertical |
|--------|-----------|-----------------------------|---------------------------|------------------------------|
| TCU 32 | N53508014 | 32000 | 19.5 | 50° |
| TCU 40 | N53508014 | 40000 | 19.5 | 36° |
| TCO 56 | N53508016 | 56000 | 30.1 | vertical |

¹set of 4 pieces

Dimensions TCO and TCU

| Model | TCU 32 | TCU 40 | TCO 56 |
|---------|--------|--------|--------|
| A, mm | 152 | 152 | 123 |
| B, mm | 181 | 181 | 217 |
| Ø C, mm | 45 | 45 | 45 |
| D, mm | 37 | 37 | 39 |
| E, mm | 73 | 73 | 57 |
| F, mm | 75 | 75 | 101 |
| G, mm | 40 | 40 | 121 |
| I, mm | 51 | 51 | - |

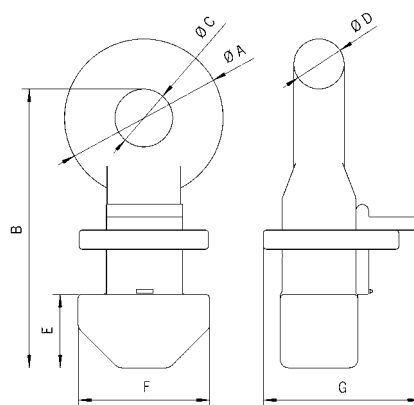

TCO

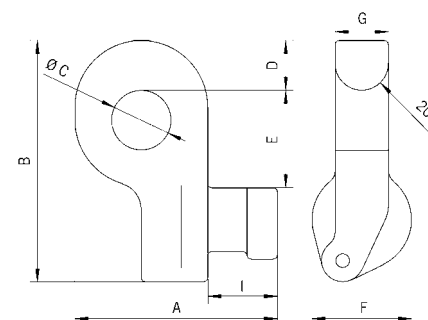

TCU

TKB Clamps for cable drums

Capacity 5000 kg

Specifically designed for the transport of cable drums, these clamps are used in pairs together with a two-legged chain sling.

By the spreading of the clamp, it locks inside the drum.

The clamps can be held in place by a locking lever.

Easy handling, light-weight design, and the size of the clamp contribute to a safe transport of all types of cable drums.



INFO

Various sizes are available on request.
Please supply dimensions C and D!

Technical data TKB

| Model | Art.-No. | Capacity ¹ kg | Weight kg |
|-------|-----------|-----------------------------|--------------|
| TKB | N52210000 | 5000 | 11 |

¹Per pair

Dimensions TKB

| Model | TKB |
|---------|-----|
| A, mm | 277 |
| B, mm | 277 |
| Ø C, mm | 82 |
| D, mm | 85 |
| Ø E, mm | 50 |

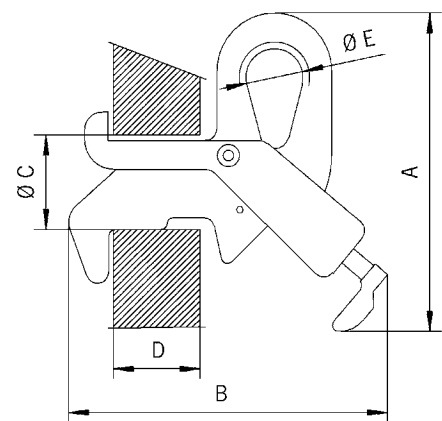



The picture shows the standard version with tines 3/4 length of the coil

TCK C-hook

Capacity 500 - 10000 kg

Coils, rolls, rings and similar items are transported safely with the Tigrip C-hooks.

Tine length and usable height with the most frequently encountered coil sizes are listed in the table below.

Other working loads, measurements, and models, such as C-hooks with automatic balancing device, are available on request.

Technical data TCK

| Model | Art.-No. | Capacity kg | Weight kg |
|---------------|-----------|-------------|-----------|
| TCK 0,5/300 | N53507801 | 500 | 21 |
| TCK 0,5/500 | N53507802 | 500 | 30 |
| TCK 0,5/800 | N53507803 | 500 | 46 |
| TCK 1,0/300 | N53507804 | 1000 | 28 |
| TCK 1,0/500 | N53507805 | 1000 | 40 |
| TCK 1,0/800 | N53507806 | 1000 | 95 |
| TCK 2,0/300 | N53507807 | 2000 | 45 |
| TCK 2,0/500 | N53507808 | 2000 | 90 |
| TCK 2,0/800 | N53507809 | 2000 | 140 |
| TCK 2,0/1000 | N53507810 | 2000 | 180 |
| TCK 3,0/300 | N53507811 | 3000 | 68 |
| TCK 3,0/500 | N53507812 | 3000 | 127 |
| TCK 3,0/800 | N53507813 | 3000 | 165 |
| TCK 3,0/1000 | N53507814 | 3000 | 215 |
| TCK 5,0/500 | N53507815 | 5000 | 184 |
| TCK 5,0/800 | N53507816 | 5000 | 238 |
| TCK 5,0/1000 | N53507817 | 5000 | 286 |
| TCK 5,0/1250 | N53507818 | 5000 | 364 |
| TCK 7,5/800 | N53507819 | 7500 | 390 |
| TCK 7,5/1000 | N53507820 | 7500 | 520 |
| TCK 7,5/1250 | N53507821 | 7500 | 650 |
| TCK 7,5/1500 | N53507822 | 7500 | 767 |
| TCK 10,0/1000 | N53507823 | 10000 | 772 |
| TCK 10,0/1250 | N53507824 | 10000 | 810 |
| TCK 10,0/1500 | N53507825 | 10000 | 980 |

Dimensions TCK

| Model | TCK 0,5/300 | TCK 0,5/500 | TCK 0,5/800 | TCK 1,0/300 | TCK 1,0/500 | TCK 1,0/800 | TCK 2,0/300 | TCK 2,0/500 | TCK 2,0/800 | TCK 2,0/1000 |
|---------------------|-------------|-------------|-------------|-------------|-------------|-------------|-------------|-------------|-------------|--------------|
| Coil width A, mm | 300 | 500 | 800 | 300 | 500 | 800 | 300 | 500 | 800 | 1000 |
| Usable height B, mm | 400 | 400 | 400 | 450 | 450 | 450 | 500 | 500 | 500 | 500 |
| C, mm | 570 | 580 | 580 | 620 | 630 | 630 | 700 | 700 | 720 | 720 |
| D, mm | 60 | 60 | 60 | 60 | 60 | 60 | 75 | 75 | 75 | 75 |
| E, mm | 120 | 120 | 120 | 120 | 120 | 120 | 150 | 150 | 150 | 150 |
| F, mm | 20 | 20 | 25 | 25 | 20 | 30 | 25 | 30 | 30 | 20 |
| G, mm | 25 | 23 | 23 | 23 | 23 | 23 | 38 | 38 | 38 | 35 |
| H, mm | 20 | 20 | 25 | 20 | 25 | 30 | 25 | 30 | 30 | 40 |
| I, mm | 50 | 65 | 70 | 70 | 80 | 90 | 90 | 110 | 125 | 125 |

| Model | TCK 3,0/300 | TCK 3,0/500 | TCK 3,0/800 | TCK 3,0/1000 | TCK 5,0/500 | TCK 5,0/800 | TCK 5,0/1000 | TCK 5,0/1250 | TCK 7,5/800 | TCK 7,5/1000 |
|---------------------|-------------|-------------|-------------|--------------|-------------|-------------|--------------|--------------|-------------|--------------|
| Coil width A, mm | 300 | 500 | 800 | 1000 | 500 | 800 | 1000 | 1250 | 800 | 1000 |
| Usable height B, mm | 500 | 500 | 500 | 500 | 550 | 550 | 550 | 550 | 600 | 600 |
| C, mm | 700 | 700 | 720 | 720 | 800 | 800 | 820 | 820 | 900 | 900 |
| D, mm | 75 | 75 | 75 | 75 | 100 | 100 | 100 | 100 | 110 | 110 |
| E, mm | 150 | 150 | 150 | 150 | 200 | 200 | 200 | 200 | 220 | 220 |
| F, mm | 30 | 20 | 25 | 20 | 25 | 30 | 30 | 30 | 35 | 35 |
| G, mm | 38 | 40 | 40 | 40 | 45 | 45 | 45 | 45 | 50 | 50 |
| H, mm | 30 | 30 | 40 | 40 | 40 | 50 | 50 | 50 | 50 | 60 |
| I, mm | 105 | 125 | 140 | 155 | 145 | 160 | 180 | 200 | 200 | 200 |

| Model | TCK 7,5/1250 | TCK 7,5/1500 | TCK 10,0/1000 | TCK 10,0/1250 | TCK 10,0/1500 |
|---------------------|--------------|--------------|---------------|---------------|---------------|
| Coil width A, mm | 1250 | 1500 | 1000 | 1250 | 1500 |
| Usable height B, mm | 600 | 600 | 650 | 650 | 650 |
| C, mm | 900 | 920 | 980 | 1000 | 1000 |
| D, mm | 110 | 110 | 130 | 130 | 130 |
| E, mm | 220 | 220 | 250 | 250 | 250 |
| F, mm | 35 | 35 | 40 | 45 | 45 |
| G, mm | 45 | 50 | 50 | 55 | 55 |
| H, mm | 60 | 70 | 70 | 70 | 80 |
| I, mm | 220 | 220 | 220 | 240 | 240 |

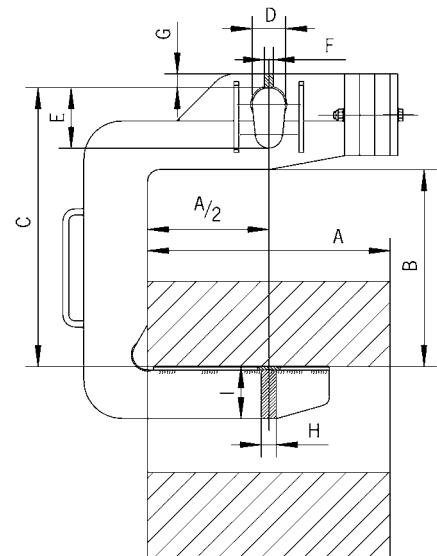

TCK specials

with 4/4 length of tines and safety nose on request



TCS Coil hook

Capacity 500 - 3000 kg

The TCS coil hook is an universal C-Hook. Due to its tipping feature, it can lift or lower the coil, whether the coil is lying flat or is in an upright position. With this tipping device, the coil is tipped safely through 90°.

The slow and safe movement of the tipping device ensures a continuous flowing movement when lifting or lowering the coil. At the same time, the tipping device serves the purpose of preventing accidental slipping of the load during transport.



INFO

Other sizes and models available on request.

Technical data TCS

| Model | Art.-No. | Capacity kg | Weight kg |
|-------------|-----------|-------------|-----------|
| TCS 0,5/120 | N53507850 | 500 | 6.9 |
| TCS 0,5/200 | N53507851 | 500 | 9.6 |
| TCS 1,0/200 | N53507852 | 1000 | 15.4 |
| TCS 1,0/300 | N53507853 | 1000 | 20.0 |
| TCS 2,0/200 | N53507854 | 2000 | 24.8 |
| TCS 2,0/300 | N53507855 | 2000 | 33.4 |
| TCS 3,0/200 | N53507856 | 3000 | 45.0 |
| TCS 3,0/300 | N53507857 | 3000 | 51.0 |

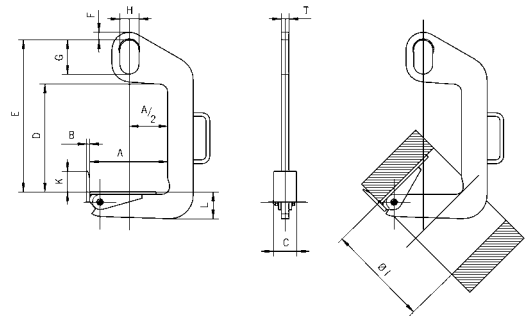

Dimensions TCS

| Model | TCS 0,5/120 | TCS 0,5/200 | TCS 1,0/200 | TCS 1,0/300 | TCS 2,0/200 | TCS 2,0/300 | TCS 3,0/200 | TCS 3,0/300 |
|-----------------------|-------------|-------------|-------------|-------------|-------------|-------------|-------------|-------------|
| Coil width A min, mm | 50 | 100 | 100 | 200 | 100 | 200 | 100 | 200 |
| Coil width A max., mm | 120 | 200 | 200 | 300 | 200 | 300 | 200 | 300 |
| B, mm | 10 | 10 | 10 | 10 | 12 | 12 | 15 | 15 |
| C, mm | 60 | 60 | 80 | 80 | 90 | 90 | 100 | 100 |
| D, mm | 330 | 330 | 460 | 460 | 420 | 420 | 610 | 610 |
| E, mm | 470 | 470 | 600 | 600 | 600 | 600 | 820 | 820 |
| F, mm | 20 | 20 | 20 | 20 | 30 | 30 | 40 | 40 |
| G, mm | 110 | 110 | 110 | 110 | 135 | 135 | 160 | 160 |
| H, mm | 60 | 60 | 60 | 60 | 75 | 75 | 90 | 90 |
| K, mm | 50 | 50 | 60 | 60 | 80 | 80 | 100 | 100 |
| L, mm | 45 | 50 | 65 | 70 | 85 | 95 | 100 | 110 |
| T, mm | 20 | 20 | 25 | 25 | 30 | 30 | 35 | 35 |
| Ø I, mm | 220 | 300 | 300 | 400 | 300 | 400 | 300 | 400 |



CMCO
www.cmco-hebetechnik.at

Last verboten!



TFA D

Barrel grab with tipping device

Capacity 300 kg

The grab with tipping device is suited to lift, transport as well as tipping and emptying the barrel.

In order to tip the barrel easily, it must be picked up at the correct center of gravity.



INFO

For barrels according to EN ISO 15750-2.

Technical data TFA D

| Model | Art.-No. | Capacity kg | Jaw capacity Z diameter mm | Weight kg |
|---------------|-----------|----------------|----------------------------------|--------------|
| TFA 0,3/600 D | N52203404 | 300 | 400 - 600 | 83 |

Dimensions TFA D

| Model | TFA 0,3/600 D |
|---------|---------------|
| A, mm | 600 |
| B, mm | 1150 |
| C, mm | 1525 |
| ∅ D, mm | 90 |
| E, mm | 34 |
| F, mm | 15 |
| G, mm | 200 |
| H, mm | 400 |

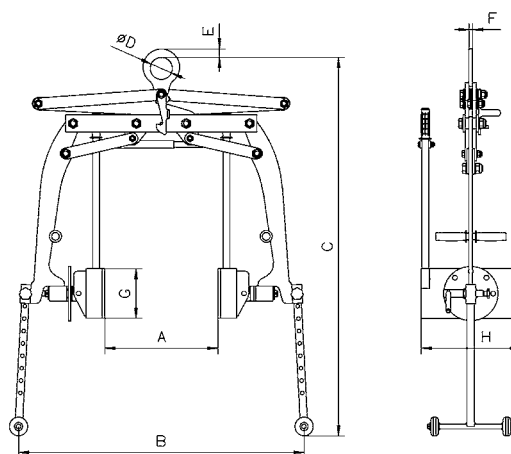

TFA 0,35/700 R and
TFA 0,35/700 TR
Barrel grab

Capacity 350 kg

These barrel grabs are designed for transport of steel barrels. The clamping jaws press securely with a positive fit underneath the rim of the barrel.



TFA-R



TFA-TR

INFO

TFA 0,35/700 TR is a combination unit for the transport of barrels that can be used with either an overhead crane or forklift.

For barrels according to EN ISO 15750-2.

Technical data TFA R/TR

| Model | Art.-No. | Capacity kg | Jaw capacity Z diameter mm | Weight kg |
|-----------------|-----------|----------------|----------------------------------|--------------|
| TFA 0,35/700 R | N52303561 | 350 | 420 - 700 | 5.7 |
| TFA 0,35/700 TR | N52303562 | 350 | 420 - 700 | 9.2 |

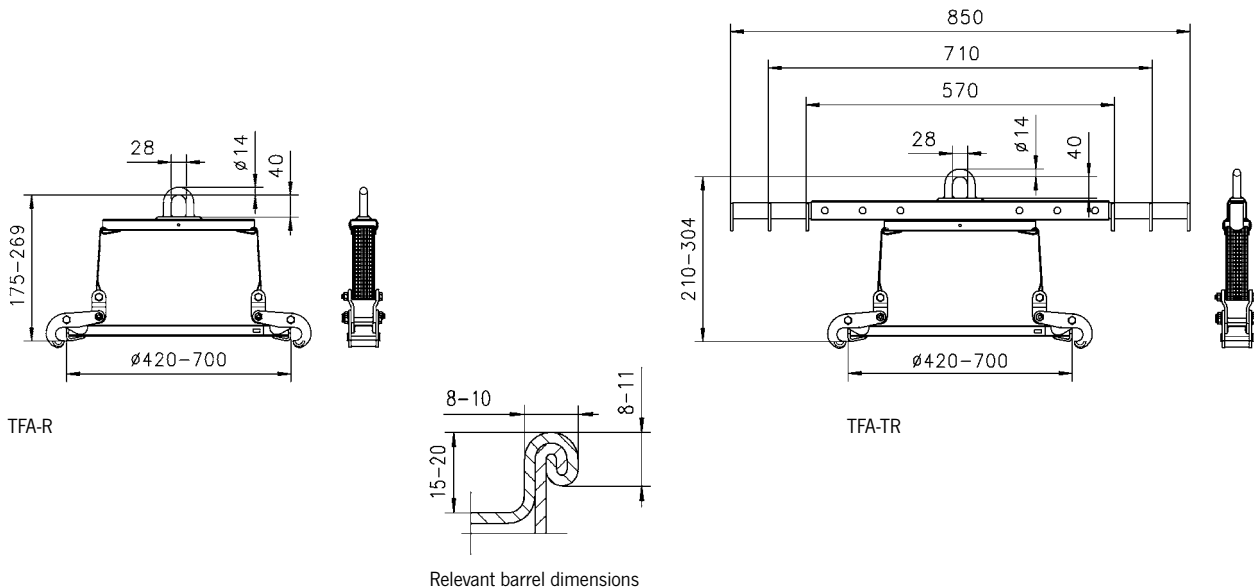



TFRK Barrel rim clamp

Capacity 500 kg

The TFRK barrel rim clamp can be used individually, as a pair, or as a multi-legged chain sling.

The clamp grabs under the rim of the barrel. A spring-loaded cam prevents the accidental opening of the clamp.

INFO

For barrels according to EN ISO 15750-2.

Technical data TFRK

| Model | Art.-No. | Capacity kg | Weight kg |
|-------|-----------|-------------|-----------|
| TFRK | N52203456 | 500 | 1.5 |

Dimensions TFRK

| Model | TFRK 0,5 |
|---------|----------|
| A, mm | 152 |
| B, mm | 150 |
| C, mm | 127 |
| D, mm | 30 |
| E, mm | 21 |
| F, mm | 41 |
| G, mm | 17 |
| Ø H, mm | 40 |

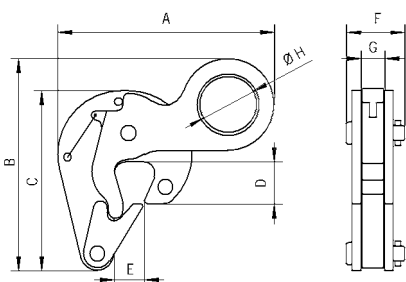

TFK
Barrel clamp

Capacity 500 kg

Its light weight and small overall design makes it ideal for lifting barrels where access or space is limited.

The center of gravity of the barrel is the lifting point during transport.



INFO

For barrels according to EN ISO 15750-2.

Technical data TFK

| Model | Art.-No. | Capacity kg | Weight kg |
|---------|-----------|-------------|-----------|
| TFK 0,5 | N52203455 | 500 | 7.3 |

Dimensions TFK

| Model | TFK 0,5 |
|---------|---------|
| A, mm | 479 |
| B, mm | 350 |
| C, mm | 410 |
| D, mm | 300 |
| Ø E, mm | 50 |

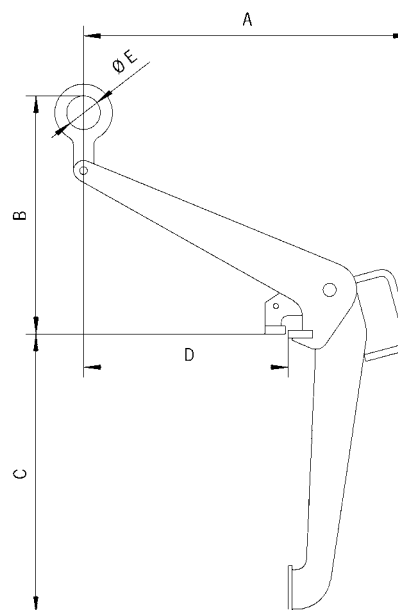



TKA/d Crate grab with tipping device

Capacity 150 kg

The crate grab with tipping device is an absolutely safe unit, which not only securely transports stacking boxes, but can empty them in mid-air as well.

The crate grab is very robust but still very easy to operate and complies with the relevant standards and EC directives.

A safety lever system prevents the accidental opening of the grab.

The clamping jaws tightly grab under the rim of the crate without damaging the crate. To engage the tipping motion in order to empty the crate, the safety lock must be manually unlocked. The tipping motion is limited to 120°. This prevents the crate from flipping completely over while emptying, thereby reducing the risk of injury.

Option

- Grabs for other sizes of crates.

INFO

Please provide the crate dimensions or a sample crate when ordering.

Technical data TKA/d

| Model | Art.-No. | Capacity kg | Weight kg |
|---------------|-----------|-------------|-----------|
| TKA 0,15/330d | N52123220 | 150 | 25.8 |
| TKA 0,15/480d | N52123225 | 150 | 26.0 |

Dimensions TKA/d

| Model | TKA 0,15/330d | TKA 0,15/480d |
|-------|---------------|---------------|
| A, mm | 200 - 300 | 300 |
| B, mm | 315 - 330 | 470 - 480 |
| L, mm | 465 - 540 | 550 - 660 |

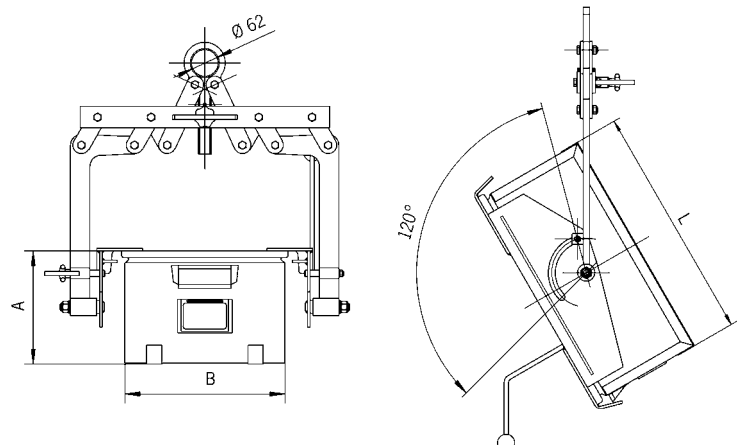

**TKA a/i
Crate grab**

Capacity 250 kg

The easy-handling crate grab, which grabs on the side plates or the front sides of the crate, transports crates safely and without damaging them.

The moveable jaws press the edge of the crate gently against the outside grab support rails. Stacking boxes made of steel or plastic will not get deformed. After the box has been set down, the safety device holds the grab open.

When lifting the crate and grabbing the support rails, the safety device must be manually pulled back until it lies over the safety bolt. With further lifting, the jaws grab under the outer top edge of the crate and lift it up safely.

The crate grab is available as an external or internal operating grab.



TKA.../...a external operating



TKA.../...i internal operating



TKA.../...i internal operating

INFO

Please provide the crate dimensions or a sample crate when ordering.

Technical data TKA a/i

| Model | Art.-No. | Capacity kg | Weight kg | Jaw capacity mm |
|---------------|-----------|-------------|-----------|-----------------|
| TKA 0,25/320a | N52103210 | 250 | 9.3 | 320 |
| TKA 0,25/480a | N52103207 | 250 | 9.3 | 480 |
| TKA 0,25/600a | N52103208 | 250 | 9.3 | 600 |
| TKA 0,25/320i | N52103204 | 250 | 8.5 | 320 |
| TKA 0,25/480i | N52103206 | 250 | 8.5 | 480 |
| TKA 0,25/600i | N52103209 | 250 | 8.5 | 600 |

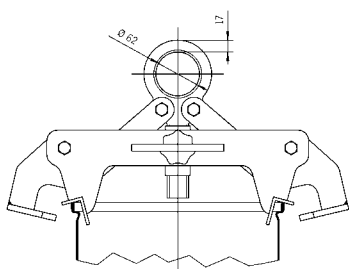

TKA.../...a external operating

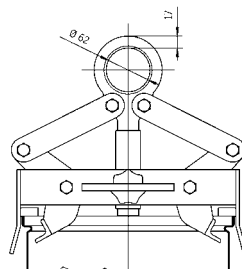
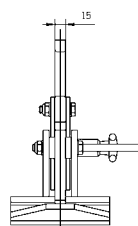

TKA.../...i internal operating

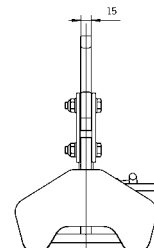



BTG Concrete pipe lifting gear

Capacity 1500 - 3000 kg

Lifting gear for the vertical transport of concrete pipe and culverts must be very versatile. Most important, it must be absolutely safe and easy to handle under even the harshest conditions.

The Tigrip concrete pipe lifting gear meets all these requirements. It is a three legged lifting system for the safe and non-marring transport of concrete pipes up to a diameter of Ø 2000 mm and a load of up to 3 t.

The jaw capacity is designed for concrete pipe thicknesses from 40 - 220 mm.

Attachment and removal of the clamps can be done easily due to the handles that have been incorporated into each clamp.

Features

- Solid design
- Safety factor 4:1
- Simple and safe handling
- Large jaw capacity
- For the toughest operating conditions
- Lightweight design
- Service-friendly

INFO

For concrete pipes according to DIN 4034.

Lifting gear for concrete pipe up to a diameter of Ø 3000 mm available on request!



Technical data BTG

| Model | Art.-No. | Capacity ¹ kg | Jaw capacity Z mm | Mouth depth E mm | Pressure line F mm | Chain Ø mm | Weight kg |
|------------------|-----------|-----------------------------|----------------------|---------------------|-----------------------|---------------|--------------|
| BTG 1,5/120 | N54609200 | 1500 | 40 - 120 | 165 | 100 | 6 | 35 |
| BTG 3,0/180 TM-N | N54609204 | 3000 | 50 - 180 | 245 | 175 | 10 | 90 |
| BTG 3,0/220 TM-N | N54609206 | 3000 | 90 - 220 | 245 | 175 | 10 | 94 |

¹Per lifting gear - three legged

Dimensions BTG

| Model | BTG 1,5/120 | BTG 3,0/180 TM-N | BTG 3,0/220 TM-N |
|---------|----------------|---------------------|---------------------|
| A, mm | 135 | 180 | 180 |
| B, mm | 75 | 100 | 100 |
| Ø C, mm | 18 | 26 | 26 |
| D, mm | 180 | 310 | 310 |

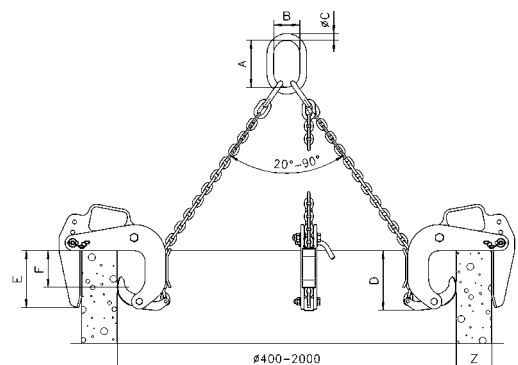

TCP
Trench shield grab

Capacity 1500 - 5500 kg

The TCP grab is suitable for vertical positioning and transportation of trench shields.

Once the grab is set onto the trench shield, a spring-loaded bolt locks itself into the hole of the shield. Releasing the bolt is done with the 15 m pull cord attached to the grab.



Technical data TCP

| Model | Art.-No. | Capacity kg | Weight kg |
|---------|-----------|-------------|-----------|
| TCP 1,5 | N56000001 | 1500 | 12.2 |
| TCP 3,0 | N56000002 | 3000 | 19.5 |
| TCP 5,5 | N56000003 | 5500 | 26.7 |

Dimensions TCP

| Model | TCP 1,5 | TCP 3,0 | TCP 5,5 |
|---------|---------|---------|---------|
| A, mm | 207 | 226 | 269 |
| B, mm | 488 | 517 | 575 |
| C, mm | 218 | 218 | 218 |
| D, mm | 90 | 100 | 120 |
| E, mm | 18 | 24 | 24 |
| Ø F, mm | 20 | 24 | 30 |
| G, mm | 180 | 180 | 180 |
| Ø H, mm | 50 | 63 | 89 |

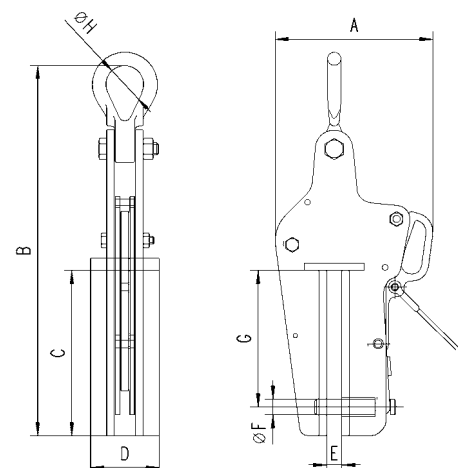



TPP

Trench shield clamp

Capacity 3000 - 8000 kg

The TPP trench shield clamp is similar to a regular plate clamp in its construction but has a much deeper jaw.

The compact construction combined with a high capacity makes it ideal for pulling trench shields out of the ground.

A safety lock prevents the accidental opening of the clamp.

Technical data TPP

| Model | Art.-No. | Capacity kg | Jaw capacity mm | Weight kg |
|-------|-----------|-------------|-----------------|-----------|
| TPP 3 | N51502418 | 3000 | 0 - 16 | 16.0 |
| TPP 8 | N51502416 | 8000 | 0 - 30 | 27.8 |

Dimensions TPP

| Model | TPP 3 | TPP 8 |
|---------|-------|-------|
| A, mm | 224 | 294 |
| B, mm | 325 | 445 |
| Ø C, mm | 20 | 30 |
| D, mm | 88 | 109 |
| E, mm | 147 | 194 |
| F, mm | 25 | 42 |
| G, mm | 123 | 146 |
| H, mm | 60 | 72 |
| I, mm | 20 | 25 |
| J, mm | 18 | 26 |

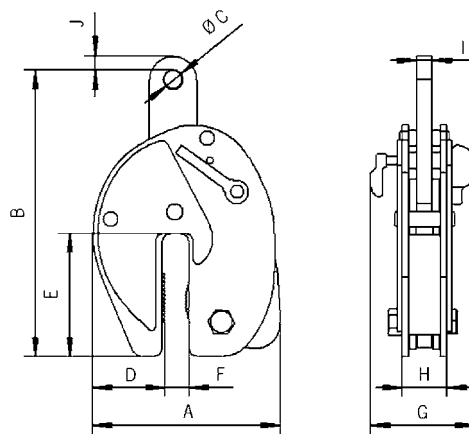

TRO

Pipe hook

Capacity 2000 - 10000 kg

The pipe hooks are used in pairs for the safe transport of pipes.

Scope of delivery

The shackles are included with the hooks.

Technical data TRO für 60° - 90° chain-top angle

| Model | Art.-No. | Capacity ¹ kg | Weight ¹ kg |
|-----------|-----------|-----------------------------|---------------------------|
| TRO 2/90 | N53508004 | 2000 | 3.1 |
| TRO 4/90 | N53508005 | 4000 | 5.6 |
| TRO 6/90 | N53508006 | 6000 | 10.5 |
| TRO 8/90 | N53508007 | 8000 | 17.8 |
| TRO 10/90 | N53508008 | 10000 | 22.0 |

¹Per pair

Dimensions TRO für 60° - 90° chain-top angle

| Model | TRO 2/90 | TRO 4/90 | TRO 6/90 | TRO 8/90 | TRO 10/90 |
|---------|----------|----------|----------|----------|-----------|
| t, mm | 20 | 30 | 30 | 40 | 40 |
| A, mm | 0 - 40 | 0 - 50 | 0 - 60 | 0 - 70 | 0 - 80 |
| B, mm | 35 | 40 | 51 | 55 | 69 |
| C, mm | 40 | 48 | 62 | 67 | 80 |
| D, mm | 62 | 77 | 90 | 105 | 115 |
| E, mm | 62 | 77 | 90 | 105 | 115 |
| F, mm | 116 | 142 | 173 | 190 | 221 |
| Ø G, mm | 16.3 | 24.3 | 24.3 | 30.3 | 30.3 |
| H, mm | 47.6 | 72.2 | 72.2 | 95.3 | 95.3 |
| Ø I, mm | 12.7 | 19 | 19 | 25.4 | 25.4 |
| J, mm | 30.2 | 44.5 | 44.5 | 58.7 | 58.7 |

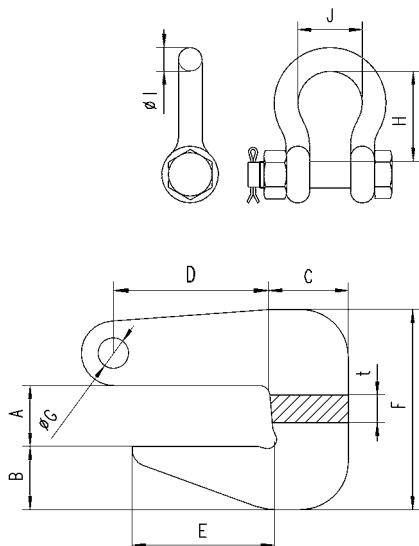

Spreader beam range

Bulkier or heavier loads must be carried on multiple points to ensure safe weight distribution and less sagging. The extensive TIGRIP® range provides a vast choice of load capacities, working widths, adjustment ranges and hook types to cater for the great majority of applications. In addition to our quality-engineered, robust and cost-effective standard range, we can also provide special designs to meet individual, bespoke customer requirements.

Options include side welding hooks (so-called cow horns), that take rope loops or lifting bands' crane eye for carrying pipes. Rolls or rollers on two or more points; star crossbars for carrying cylindrical items, or transverse crossbars for four point suspension, a further version of the reliable, easy to use and safe TIGRIP® crane hook spreader beams.

Spreader beams can be used for a diverse range of shapes and designs, and can be individually designed to meet specific applications. The following illustrations provide a short overview of the many designs available. Suspension and load carrying variants can be easily combined with most designs.



Suspension variants

Eyelet suspension

Standard suspension for use with single hooks according to DIN 15401

Possible for defined load centre of gravity for symmetrical but also asymmetrical loads.



Chain suspension

To stabilise swinging movements

Multitude of options in combination with our chain programme. Lifting ring for single hooks but also double hooks Shortening hooks allow the centre of gravity to be adjusted for asymmetrical loads.



Internal bolt suspension

To reduce the build height

Fixed welded-on but also plug-in variants possible.



Double eyelet suspension for two crane operation

Allows the spreader beam to be used on two cranes at the same time

Each suspension variant can be operated as a double suspension.



Bracket suspension

For use with double hooks according to DIN 15402

Load carrying variants

Eyehooks

with forged safety latch

For use with any sling or sling points.



Swivel hooks

Allows alignment of the hook to the sling point

Variants possible with plain-bearing mounted swivel (cannot be rotated under load) and also ball-bearing mounted swivel (can be rotated under load).



Front welded-on hook

(cow horn with safety latch)

To reduce the height on single spreader beam



Welded-on hooks

(cow horns with safety latch)

For use with two single-stranded or singly wrapped sling

Also possible with adjusting bracket.



Mounting eyelets

for fixed slings

With the mounting eyelets, the spreader beam can be combined with any slings from our programme.

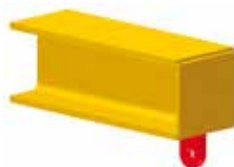

Centre hooks

For crane use if the crossbar is not required

With the centre hook there is no need to place and remove the spreader beam.

Variants possible as eyehooks or swivel hooks.





TTS-E Spreader beam, non-adjustable

Capacity 1000 - 10000 kg

For the transport of symmetrical loads.

Features

- Lifting brackets for single hook according to DIN 15401
- Eyehooks with forged safety latch

Options

- Other capacities
- Working widths according customer requirements
- Accentral suspension for asymmetrical loads

Technical data TTS-E

| Model | Art.-No. | Capacity kg | Working width Z mm | Hook mouth mm | Weight kg |
|-----------------|-----------|-------------|--------------------|---------------|-----------|
| TTS 1,0/1000 E | N53106201 | 1000 | 1000 | 23 | 23 |
| TTS 2,0/1000 E | N53106202 | 2000 | 1000 | 23 | 25 |
| TTS 3,0/1000 E | N53106203 | 3000 | 1000 | 30 | 28 |
| TTS 5,0/1000 E | N53106204 | 5000 | 1000 | 38 | 41 |
| TTS 7,5/1000 E | N53106205 | 7500 | 1000 | 42 | 50 |
| TTS 10,0/1000 E | N53106206 | 10000 | 1000 | 42 | 61 |
| TTS 1,0/1500 E | N53106211 | 1000 | 1500 | 23 | 31 |
| TTS 2,0/1500 E | N53106212 | 2000 | 1500 | 23 | 33 |
| TTS 3,0/1500 E | N53106213 | 3000 | 1500 | 30 | 41 |
| TTS 5,0/1500 E | N53106214 | 5000 | 1500 | 38 | 64 |
| TTS 7,5/1500 E | N53106215 | 7500 | 1500 | 42 | 74 |
| TTS 10,0/1500 E | N53106216 | 10000 | 1500 | 42 | 90 |
| TTS 1,0/2500 E | N53106221 | 1000 | 2500 | 23 | 46 |
| TTS 2,0/2500 E | N53106222 | 2000 | 2500 | 23 | 69 |
| TTS 3,0/2500 E | N53106223 | 3000 | 2500 | 30 | 88 |
| TTS 5,0/2500 E | N53106224 | 5000 | 2500 | 38 | 106 |
| TTS 7,5/2500 E | N53106225 | 7500 | 2500 | 42 | 148 |
| TTS 10,0/2500 E | N53106226 | 10000 | 2500 | 42 | 181 |
| TTS 1,0/3500 E | N53106231 | 1000 | 3500 | 23 | 77 |
| TTS 2,0/3500 E | N53106232 | 2000 | 3500 | 23 | 118 |
| TTS 3,0/3500 E | N53106233 | 3000 | 3500 | 30 | 138 |
| TTS 5,0/3500 E | N53106234 | 5000 | 3500 | 38 | 167 |
| TTS 7,5/3500 E | N53106235 | 7500 | 3500 | 42 | 235 |
| TTS 10,0/3500 E | N53106236 | 10000 | 3500 | 42 | 272 |
| TTS 1,0/5000 E | N53106241 | 1000 | 5000 | 23 | 163 |
| TTS 2,0/5000 E | N53106242 | 2000 | 5000 | 23 | 189 |
| TTS 3,0/5000 E | N53106243 | 3000 | 5000 | 30 | 223 |
| TTS 5,0/5000 E | N53106244 | 5000 | 5000 | 38 | 295 |
| TTS 7,5/5000 E | N53106245 | 7500 | 5000 | 42 | 372 |
| TTS 10,0/5000 E | N53106246 | 10000 | 5000 | 42 | 478 |

Dimensions TTS-E

| Model | TTS 1,0/1000 E | TTS 2,0/1000 E | TTS 3,0/1000 E | TTS 5,0/1000 E | TTS 7,5/1000 E | TTS 10,0/1000 E |
|-------|-------------------|-------------------|-------------------|-------------------|-------------------|--------------------|
| B, mm | 405 | 430 | 500 | 615 | 720 | 800 |
| C, mm | 110 | 135 | 160 | 180 | 200 | 260 |
| D, mm | 25 | 30 | 35 | 40 | 60 | 70 |
| E, mm | 60 | 75 | 90 | 100 | 130 | 130 |

| Model | TTS 1,0/1500 E | TTS 2,0/1500 E | TTS 3,0/1500 E | TTS 5,0/1500 E | TTS 7,5/1500 E | TTS 10,0/1500 E |
|-------|-------------------|-------------------|-------------------|-------------------|-------------------|--------------------|
| B, mm | 405 | 430 | 520 | 635 | 740 | 820 |
| C, mm | 110 | 135 | 160 | 180 | 200 | 260 |
| D, mm | 25 | 30 | 35 | 40 | 60 | 70 |
| E, mm | 60 | 75 | 90 | 100 | 130 | 130 |

| Model | TTS 1,0/2500 E | TTS 2,0/2500 E | TTS 3,0/2500 E | TTS 5,0/2500 E | TTS 7,5/2500 E | TTS 10,0/2500 E |
|-------|-------------------|-------------------|-------------------|-------------------|-------------------|--------------------|
| B, mm | 405 | 470 | 560 | 655 | 780 | 860 |
| C, mm | 110 | 135 | 160 | 180 | 200 | 260 |
| D, mm | 25 | 30 | 35 | 40 | 60 | 70 |
| E, mm | 60 | 75 | 90 | 100 | 130 | 130 |

| Model | TTS 1,0/3500 E | TTS 2,0/3500 E | TTS 3,0/3500 E | TTS 5,0/3500 E | TTS 7,5/3500 E | TTS 10,0/3500 E |
|-------|-------------------|-------------------|-------------------|-------------------|-------------------|--------------------|
| B, mm | 435 | 490 | 580 | 695 | 800 | 880 |
| C, mm | 110 | 135 | 160 | 180 | 200 | 260 |
| D, mm | 25 | 30 | 35 | 40 | 60 | 70 |
| E, mm | 60 | 75 | 90 | 100 | 130 | 130 |

| Model | TTS 1,0/5000 E | TTS 2,0/5000 E | TTS 3,0/5000 E | TTS 5,0/5000 E | TTS 7,5/5000 E | TTS 10,0/5000 E |
|-------|-------------------|-------------------|-------------------|-------------------|-------------------|--------------------|
| B, mm | 475 | 510 | 600 | 715 | 820 | 920 |
| C, mm | 110 | 135 | 160 | 180 | 200 | 260 |
| D, mm | 25 | 30 | 35 | 40 | 60 | 70 |
| E, mm | 60 | 75 | 90 | 100 | 130 | 130 |

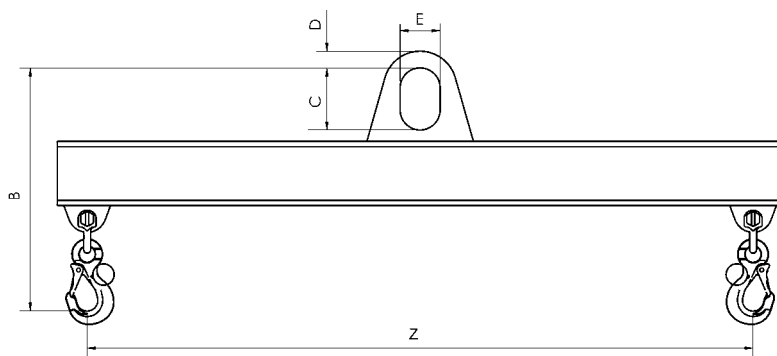

INFO

The spreader beams can be combined with the different suspension types (see pages 202-203).



TTS Spreader beam, adjustable

Capacity 1000 - 25000 kg

For the transport of symmetrical and asymmetrical loads.

Features

- Lifting brackets for single hook according to DIN 15401
- Adjustment with grids
- Adjustable bracket with handle and swivel hook (cannot be rotated under load)

Technical data TTS

| Model | Art.-No. | Capacity kg | Working width Z mm | Hook mouth mm | Weight kg |
|---------------|-----------|-------------|--------------------|---------------|-----------|
| TTS 1,0/1500 | N53106001 | 1000 | 700 - 1500 | 18 | 40 |
| TTS 2,0/1500 | N53106002 | 2000 | 700 - 1500 | 18 | 41 |
| TTS 3,0/1500 | N53106003 | 3000 | 700 - 1500 | 21 | 53 |
| TTS 5,0/1500 | N53106004 | 5000 | 700 - 1500 | 23 | 79 |
| TTS 7,5/1500 | N53106005 | 7500 | 700 - 1500 | 32 | 98 |
| TTS 10,0/1500 | N53106006 | 10000 | 700 - 1500 | 32 | 117 |
| TTS 12,5/1500 | N53106007 | 12500 | 700 - 1500 | 40 | 116 |
| TTS 15,0/1500 | N53106008 | 15000 | 700 - 1500 | 40 | 137 |
| TTS 20,0/1500 | N53106009 | 20000 | 700 - 1500 | 50 | 180 |
| TTS 25,0/1500 | N53106010 | 25000 | 700 - 1500 | 50 | 226 |
| TTS 1,0/2500 | N53106011 | 1000 | 1500 - 2500 | 18 | 58 |
| TTS 2,0/2500 | N53106012 | 2000 | 1500 - 2500 | 18 | 84 |
| TTS 3,0/2500 | N53106013 | 3000 | 1500 - 2500 | 21 | 105 |
| TTS 5,0/2500 | N53106014 | 5000 | 1500 - 2500 | 23 | 127 |
| TTS 7,5/2500 | N53106015 | 7500 | 1500 - 2500 | 32 | 178 |
| TTS 10,0/2500 | N53106016 | 10000 | 1500 - 2500 | 32 | 215 |
| TTS 12,5/2500 | N53106017 | 12500 | 1500 - 2500 | 40 | 198 |
| TTS 15,0/2500 | N53106018 | 15000 | 1500 - 2500 | 40 | 237 |
| TTS 20,0/2500 | N53106019 | 20000 | 1500 - 2500 | 50 | 287 |
| TTS 25,0/2500 | N53106020 | 25000 | 1500 - 2500 | 50 | 342 |
| TTS 1,0/3500 | N53106021 | 1000 | 1700 - 3500 | 18 | 95 |
| TTS 2,0/3500 | N53106022 | 2000 | 1700 - 3500 | 18 | 137 |
| TTS 3,0/3500 | N53106023 | 3000 | 1700 - 3500 | 21 | 162 |
| TTS 5,0/3500 | N53106024 | 5000 | 1700 - 3500 | 23 | 228 |
| TTS 7,5/3500 | N53106025 | 7500 | 1700 - 3500 | 32 | 278 |
| TTS 10,0/3500 | N53106026 | 10000 | 1700 - 3500 | 32 | 317 |
| TTS 12,5/3500 | N53106027 | 12500 | 1700 - 3500 | 40 | 295 |
| TTS 15,0/3500 | N53106028 | 15000 | 1700 - 3500 | 40 | 340 |
| TTS 20,0/3500 | N53106029 | 20000 | 1700 - 3500 | 50 | 451 |
| TTS 25,0/3500 | N53106030 | 25000 | 1700 - 3500 | 50 | 512 |
| TTS 1,0/5000 | N53106031 | 1000 | 2000 - 5000 | 18 | 190 |
| TTS 2,0/5000 | N53106032 | 2000 | 2000 - 5000 | 18 | 219 |
| TTS 3,0/5000 | N53106033 | 3000 | 2000 - 5000 | 21 | 260 |
| TTS 5,0/5000 | N53106034 | 5000 | 2000 - 5000 | 23 | 372 |
| TTS 7,5/5000 | N53106035 | 7500 | 2000 - 5000 | 32 | 423 |
| TTS 10,0/5000 | N53106036 | 10000 | 2000 - 5000 | 32 | 531 |
| TTS 12,5/5000 | N53106037 | 12500 | 2000 - 5000 | 40 | 449 |
| TTS 15,0/5000 | N53106038 | 15000 | 2000 - 5000 | 40 | 568 |
| TTS 20,0/5000 | N53106039 | 20000 | 2000 - 5000 | 50 | 691 |
| TTS 1,0/8000 | N53106040 | 1000 | 3000 - 8000 | 18 | 342 |
| TTS 2,0/8000 | N53106041 | 2000 | 3000 - 8000 | 18 | 458 |
| TTS 3,0/8000 | N53106042 | 3000 | 3000 - 8000 | 21 | 547 |
| TTS 5,0/8000 | N53106043 | 5000 | 3000 - 8000 | 23 | 788 |
| TTS 7,5/8000 | N53106044 | 7500 | 3000 - 8000 | 32 | 883 |
| TTS 10,0/8000 | N53106045 | 10000 | 3000 - 8000 | 32 | 1319 |
| TTS 12,5/8000 | N53106046 | 12500 | 3000 - 8000 | 40 | 979 |
| TTS 15,0/8000 | N53106047 | 15000 | 3000 - 8000 | 40 | 1046 |

Dimensions TTS

| Model | TTS 1,0/1500 | TTS 2,0/1500 | TTS 3,0/1500 | TTS 5,0/1500 | TTS 7,5/1500 | TTS 10,0/1500 | TTS 12,5/1500 | TTS 15,0/1500 | TTS 20,0/1500 | TTS 25,0/1500 |
|-------|--------------|--------------|--------------|--------------|--------------|---------------|---------------|---------------|---------------|---------------|
| B, mm | 440 | 470 | 570 | 655 | 740 | 835 | 865 | 910 | 1020 | 1230 |
| C, mm | 110 | 135 | 160 | 180 | 200 | 260 | 260 | 260 | 260 | 300 |
| D, mm | 25 | 30 | 35 | 40 | 60 | 70 | 75 | 85 | 90 | 100 |
| E, mm | 60 | 75 | 90 | 100 | 130 | 130 | 140 | 140 | 160 | 160 |

| Model | TTS 1,0/2500 | TTS 2,0/2500 | TTS 3,0/2500 | TTS 5,0/2500 | TTS 7,5/2500 | TTS 10,0/2500 | TTS 12,5/2500 | TTS 15,0/2500 | TTS 20,0/2500 | TTS 25,0/2500 |
|-------|--------------|--------------|--------------|--------------|--------------|---------------|---------------|---------------|---------------|---------------|
| B, mm | 440 | 505 | 610 | 675 | 785 | 880 | 915 | 955 | 1060 | 1255 |
| C, mm | 110 | 135 | 160 | 180 | 200 | 260 | 260 | 260 | 260 | 300 |
| D, mm | 25 | 30 | 35 | 40 | 60 | 70 | 75 | 85 | 90 | 100 |
| E, mm | 60 | 75 | 90 | 100 | 130 | 130 | 140 | 140 | 160 | 160 |

| Model | TTS 1,0/3500 | TTS 2,0/3500 | TTS 3,0/3500 | TTS 5,0/3500 | TTS 7,5/3500 | TTS 10,0/3500 | TTS 12,5/3500 | TTS 15,0/3500 | TTS 20,0/3500 | TTS 25,0/3500 |
|-------|--------------|--------------|--------------|--------------|--------------|---------------|---------------|---------------|---------------|---------------|
| B, mm | 440 | 530 | 635 | 715 | 810 | 905 | 935 | 980 | 1115 | 1300 |
| C, mm | 110 | 135 | 160 | 180 | 200 | 260 | 260 | 260 | 260 | 300 |
| D, mm | 25 | 30 | 35 | 40 | 60 | 70 | 75 | 85 | 90 | 100 |
| E, mm | 60 | 75 | 90 | 100 | 130 | 130 | 140 | 140 | 160 | 160 |

| Model | TTS 1,0/5000 | TTS 2,0/5000 | TTS 3,0/5000 | TTS 5,0/5000 | TTS 7,5/5000 | TTS 10,0/5000 | TTS 12,5/5000 | TTS 15,0/5000 | TTS 20,0/5000 |
|-------|--------------|--------------|--------------|--------------|--------------|---------------|---------------|---------------|---------------|
| B, mm | 495 | 550 | 655 | 740 | 830 | 950 | 980 | 1025 | 1155 |
| C, mm | 110 | 135 | 160 | 180 | 200 | 260 | 260 | 260 | 260 |
| D, mm | 25 | 30 | 35 | 40 | 60 | 70 | 75 | 85 | 90 |
| E, mm | 60 | 75 | 90 | 100 | 130 | 130 | 140 | 140 | 160 |

| Model | TTS 1,0/8000 | TTS 2,0/8000 | TTS 3,0/8000 | TTS 5,0/8000 | TTS 7,5/8000 | TTS 10,0/8000 | TTS 12,5/8000 | TTS 15,0/8000 |
|-------|--------------|--------------|--------------|--------------|--------------|---------------|---------------|---------------|
| B, mm | 515 | 590 | 700 | 785 | 895 | 1010 | 1045 | 1085 |
| C, mm | 110 | 135 | 160 | 180 | 200 | 260 | 260 | 260 |
| D, mm | 25 | 30 | 35 | 40 | 60 | 70 | 75 | 85 |
| E, mm | 60 | 75 | 90 | 100 | 130 | 130 | 140 | 140 |

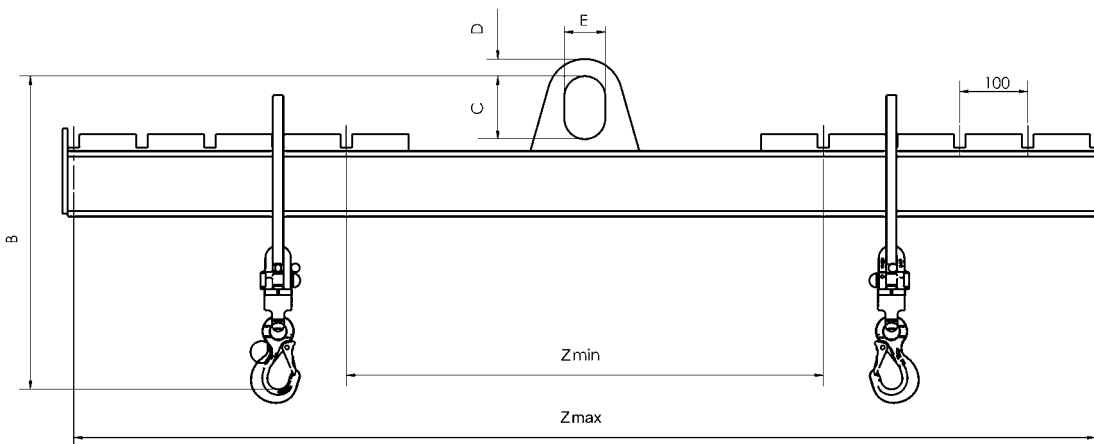

INFO

The spreader beams can be combined with the different suspension types (see pages 202-203).



TTS-HE
H-frame spreader beam

Capacity up to 10000 kg
For the transport of symmetrical loads.

Features

- Lifting brackets for single hook according to DIN 15401
- Eyehooks with forged safety latch

Option

- Accentral suspension for asymmetrical loads

Technical questionnaire

Capacity _____ kg
Working length _____ mm
Working width _____ mm

INFO

Capacity, working length and width designed on individual customer requirements.

The spreader beams can be combined with the different suspension types (see pages 202-203).



TTS-H
H-frame spreader beam

Capacity up to 25000 kg
For the transport of symmetrical and asymmetrical loads.

Features

- Lifting brackets for single hook according to DIN 15401
- Adjustment with grids
- Adjustable bracket with handle and swivel hook (cannot be rotated under load)

Technical questionnaire

Capacity _____ kg
Working length, min. _____ mm
Working length, max. _____ mm
Working width, min. _____ mm
Working width, max. _____ mm

INFO

Capacity, working length and width designed on individual customer requirements.

The spreader beams can be combined with the different suspension types (see pages 202-203).

TTS
Spreader beam for box pallets

Capacity 1000 - 3000 kg

Box pallets with DIN 15155 specifications, are usually moved around with a forklift, but are so sturdy that they can be picked up and transported with a spreader beam grab and an overhead crane hooked up to the top of the box pallet's frame.

Thanks to these spreader beams, the shipping and receiving area is no longer entirely dependent on floor-level material handling equipment such as forklifts.

The version designed for the individual transport of box pallets is equipped with two fixed yokes and two pivoted ones, interconnected with a control bar. The load tackling gear is fixed and unfixed by only one person.



Technical data TTS

| Model | Art.-No. | Capacity kg | Weight kg |
|--------------------|-----------|-------------|-----------|
| TTS 1,0/1240 - 810 | N53207001 | 1000 | 38 |
| TTS 2,0/1240 - 810 | N53207002 | 2000 | 61 |
| TTS 3,0/1240 - 810 | N53207003 | 3000 | 80 |

Dimensions TTS

| Model | TTS 1,0/1240 - 810 | TTS 2,0/1240 - 810 | TTS 3,0/1240 - 810 |
|-------|--------------------|--------------------|--------------------|
| B, mm | 600 | 600 | 600 |
| C, mm | 410 | 495 | 520 |
| D, mm | 195 | 215 | 215 |
| E, mm | 125 | 180 | 205 |
| F, mm | 100 | 150 | 170 |
| G, mm | 80 | 100 | 130 |
| H, mm | 28 | 30 | 40 |
| I, mm | 15 | 20 | 25 |
| Z, mm | 1175 | 1175 | 1175 |

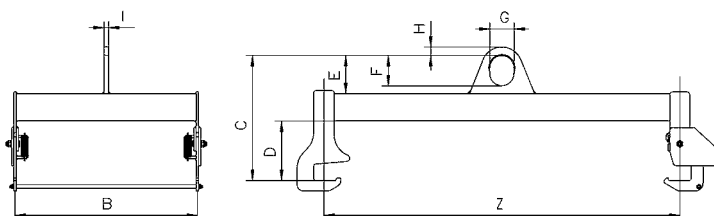



TTB Spreader beam for Big-Bags

Capacity 1000 - 2000 kg

This four-point spreader beam in a fixed frame construction with weld-on hooks and safety latch is designed for lifting and transporting of Big-Bags.

Technical data TTB

| Model | Art.-No. | Capacity kg | Working width Z mm | Weight kg |
|---------------------|-----------|-------------|--------------------|-----------|
| TTB 1,0/1090 - 1090 | N53156300 | 1000 | 750 - 800 | 27 |
| TTB 1,0/1320 - 1320 | N53156301 | 1000 | 900 - 970 | 33 |
| TTB 2,0/1090 - 1090 | N53156302 | 2000 | 750 - 800 | 42 |
| TTB 2,0/1320 - 1320 | N53156303 | 2000 | 900 - 970 | 44 |

Dimensions TTB

| Model | TTB 1,0/1090 - 1090 | TTB 1,0/1320 - 1320 | TTB 2,0/1090 - 1090 | TTB 2,0/1320 - 1320 |
|-------|------------------------|------------------------|------------------------|------------------------|
| B, mm | 210 | 210 | 240 | 240 |
| C, mm | 60 | 60 | 75 | 75 |
| D, mm | 110 | 110 | 135 | 135 |

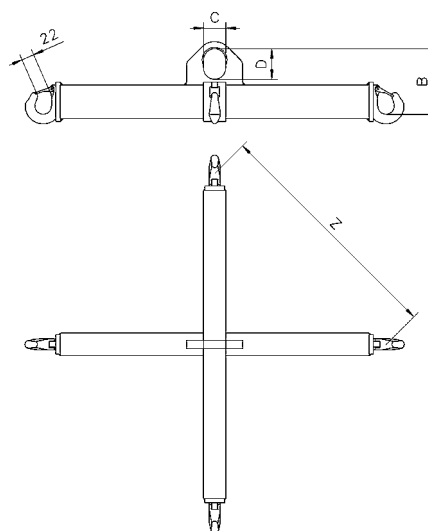

TTS-Z
Fork lift cross beam

Capacity 2000 - 3150 kg

The model TTS-Z with two bags is used for forklift tines and has one centered, pivoting eye hook (do not pivot under load). The fork lift cross beam is fastened with two spindles and ensures safety while lifting.

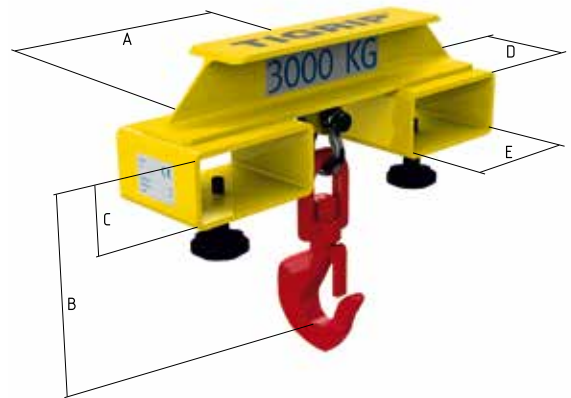

Technical data TTS-Z

| Model | Art.-No. | Capacity kg | Height B mm | Dim. C mm | Dim. D mm | Dim. E mm | Weight kg |
|------------|-------------|-------------|-------------|-----------|-----------|-----------|-----------|
| TTS 2,0/Z | N4300000170 | 2000 | 246 | 70 | 160 | 150 | 14.0 |
| TTS 3,15/Z | N4300015315 | 3150 | 274 | 84 | 160 | 184 | 19.0 |

TZH
Tine hook

Capacity 1500 - 5000 kg

For fastening hoisting equipment and loads to single forklift tines. The TZH are pushed onto the forklift tines and are fastened with two spindles. The pivoting as well as swivelling hook with safety latch ensures safety while lifting.



Technical data TZH

| Model | Art.-No. | Capacity kg | Weight kg |
|-------------|-----------|-------------|-----------|
| TZH 1,5/150 | N55100001 | 1500 | 7.2 |
| TZH 3,0/150 | N55100002 | 3000 | 10.8 |
| TZH 5,0/150 | N55100004 | 5000 | 17.3 |

Dimensions TZH

| Model | TZH 1,5/150 | TZH 3,0/150 | TZH 5,0/150 |
|------------|-------------|-------------|-------------|
| A, mm | 100 | 100 | 100 |
| B, mm | 150 | 150 | 150 |
| C min., mm | 310 | 350 | 350 |
| C max., mm | 360 | 400 | 400 |
| D, mm | 260 | 270 | 295 |
| E, mm | 74 | 74 | 74 |
| F, mm | 120 | 120 | 120 |
| G, mm | 25 | 28 | 34 |

INFO

Attention must be paid to the working load limit of the single forklift tines.

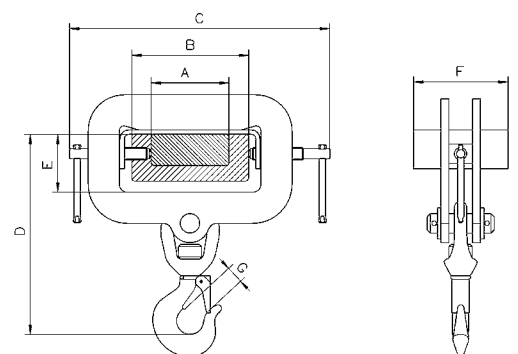

TZH, swivel hooks, pivoting and swivelling

INFO

For the transport of loads above persons (e.g. on construction sites) appropriate security measures against falling loads or parts must be taken.

The load must not exceed the fork length.



TKG vhs Crane forks

Capacity 200 - 5000 kg

These crane forks are equipped with adjustable tines, height adjustability and an automatic balancing system. Crane forks with automatic balancing* tend to point their tines upward when being transported. This prevents the load from unintentionally slipping off the tines.

The shackle is movable and runs on a track depending on the load. The automatic balancing engages by a pressurized gas spring once the forks are loaded. The load will always be in the center of gravity of the forks, ensuring a safe transport.

***The automatic balancing system requires a minimum load of 20% of the crane forks' working load limit!**

Features

- All crane forks comply with the latest standards and CE-directives.
- Safety factor 4:1
- Maintenance-free
- Highly visible safety colour
- For the transport of rings or coils, the fork tines are simply pushed together.
- Easily adjustable tines for all pallet sizes.

Scope of delivery

Chain for load securing

Technical data TKG vhs

| Model | Art.-No. | Capacity kg | Weight kg |
|-------------|-----------|-------------|-----------|
| TKG 1,0 vhs | N53407531 | 200 - 1000 | 128 |
| TKG 1,5 vhs | N53407532 | 300 - 1500 | 158 |
| TKG 2,0 vhs | N53407533 | 400 - 2000 | 203 |
| TKG 3,0 vhs | N53407534 | 600 - 3000 | 260 |
| TKG 5,0 vhs | N53407535 | 1000 - 5000 | 413 |

Dimensions TKG vhs

| Model | TKG 1,0 vhs | TKG 1,5 vhs | TKG 2,0 vhs | TKG 3,0 vhs | TKG 5,0 vhs |
|---------------------------|-------------|-------------|-------------|-------------|-------------|
| Adjustment of tines A, mm | 350 - 900 | 350 - 900 | 400 - 900 | 450 - 900 | 500 - 1000 |
| Usable height B, mm | 1100 - 1600 | 1300 - 2000 | 1300 - 2000 | 1300 - 2000 | 1300 - 2000 |
| Length of tines C, mm | 1000 | 1000 | 1000 | 1000 | 1000 |
| Section of tines D, mm | 100 x 30 | 100 x 40 | 120 x 40 | 120 x 50 | 150 x 60 |
| Overall height E, mm | 1420 - 1920 | 1650 - 2350 | 1655 - 2355 | 1720 - 2420 | 1710 - 2410 |

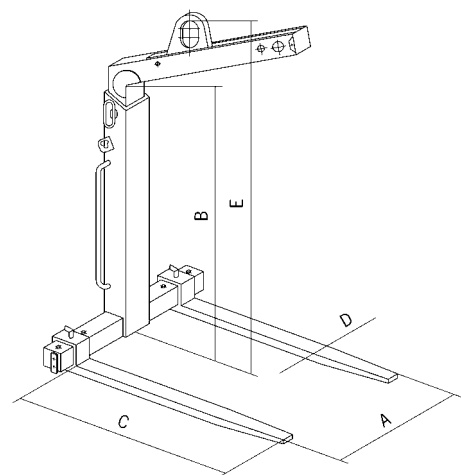

TKG vh Crane forks

Capacity 1000 - 5000 kg

These crane forks are equipped with adjustable tines and height adjustability. The balancing system engages when the shackle is manually hooked into the appropriate notch.

Features

- All crane forks comply with the latest standards and CE-directives.
- Safety factor 4:1
- Maintenance-free
- Highly visible safety colour
- For the transport of rings or coils, the fork tines are simply pushed together.
- Easily adjustable tines for all pallet sizes.

Scope of delivery

Chain for load securing



INFO

The load must not exceed the fork length.

Technical data TKG vh

| Model | Art.-No. | Capacity kg | Weight kg |
|------------|-----------|-------------|-----------|
| TKG 1,0 vh | N53407511 | 1000 | 128 |
| TKG 1,5 vh | N53407512 | 1500 | 148 |
| TKG 2,0 vh | N53407513 | 2000 | 193 |
| TKG 3,0 vh | N53407514 | 3000 | 248 |
| TKG 5,0 vh | N53407515 | 5000 | 388 |

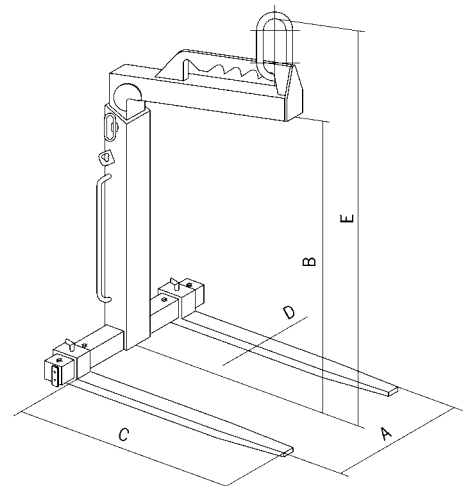

Dimensions TKG vh

| Model | TKG 1,0 vh | TKG 1,5 vh | TKG 2,0 vh | TKG 3,0 vh | TKG 5,0 vh |
|---------------------------|-------------|-------------|-------------|-------------|-------------|
| Adjustment of tines A, mm | 350 - 900 | 350 - 900 | 400 - 900 | 450 - 900 | 500 - 1000 |
| Usable height B, mm | 1100 - 1600 | 1300 - 2000 | 1300 - 2000 | 1300 - 2000 | 1300 - 2000 |
| Length of tines C, mm | 1000 | 1000 | 1000 | 1000 | 1000 |
| Section of tines D, mm | 100 x 30 | 100 x 40 | 120 x 40 | 120 x 50 | 150 x 60 |
| Overall height E, mm | 1390 - 1890 | 1600 - 2300 | 1640 - 2340 | 1670 - 2370 | 1700 - 2400 |



-TKI with digital display and radio control

The crane weigher can be operated by radio control. The displayed values can be taken off the remote control device and can be transferred to a PC. Several measured values can be totalled and saved. Various functions like piece counting, maximum weight (gross/net) can be realized.

Features

- TKI crane weigher has the same features like the model TKE.
- Remote control and data exchange via radio transmission.
- USB interface
- Accumulation memory

Options

- User software for data processing
- PC cable
- Lower hook

Scope of delivery

- Crane weigher with infrared remote control
- Remote control and data exchange via radio transmission.
- 8 x 1.5V AA batteries
- Carrying case
- Test certificate
- Upper and lower shackle

Crane weighers

Measuring range 0 - 9.5 t

The crane weighers TKE and TKI are compact measuring devices for the weighing of loads.

Due to the compact design and robust steel housing the crane weighers are suitable for a wide range of applications. The crane weighers have a liquid crystal display (LCD), which can tare as well as show either the gross or the net load.

Both models TKE and TKI are fitted with an infrared remote control with a range of 8 m.

- TKE with digital display

Features

- High accuracy: $\pm 0,03\%$ of the weighing range
- Lightweight design
- Easy-to-read display
- Easy to use
- Robust design
- Retains the peak value to memory.
- Operating time of about 40 hours (without radio frequency communication)
- Automatic setting to zero when load indicator is switched on.
- Display of maximum weight (gross/net).
- Display of measuring units on the load indicator.
- Measuring units g, kg, t and lbs.
- Automatic stand-by for a prolonged battery lifetime.

Option

- Lower hook

Scope of delivery

- Crane weigher with with infrared remote control
- 4 x 1.5V AA batteries
- Carrying case
- Test certificate
- Upper and lower shackle

Technical data TKE and TKI

| Model | TKE 1,5 TKI 1,5 | | | TKE 6,0 TKI 6,0 | | | TKE 9,5 TKI 9,5 | | |
|---|---|------------------|-------------------|--------------------|-------------------|-------------------|--------------------|-------------------|-------------------|
| | Art.-No. TKE | N53908560 | | | N53908561 | | | N53908562 | |
| Art.-No. TKI | N53908566 | | | N53908567 | | | N53908568 | | |
| Measuring range, t | 0 - 1.5 | | | 0 - 6.0 | | | 0 - 9.5 | | |
| Breaking load, t | ≥ 4.5 | | | ≥ 24.0 | | | ≥ 38.0 | | |
| Weight with lifting accessories, kg | 6 | | | 10 | | | 15 | | |
| Resolution step, kg (partition) | up to 300 0.1 | up to 600 0.2 | up to 1500 0.5 | up to 1500 0.5 | up to 3000 1.0 | up to 6000 2.0 | up to 3000 1.0 | up to 6000 2.0 | up to 9500 5.0 |
| Operation time, approx., h ¹ | 40 | | | | | | | | |
| Temperature range (operation) | - 10 °C up to + 40 °C | | | | | | | | |
| Temperature range (storage) | - 10 °C up to + 40 °C | | | | | | | | |
| Protection | IP 40 | | | | | | | | |
| Display (LCD 25 mm high) | 5 ½ digits | | | | | | | | |
| Tare range | 100% of rated capacity | | | | | | | | |
| Overload warning | The crane weigher switches off when exceeding the rated load. | | | | | | | | |

¹with 4 x 1.5 V AA batteries (without radio frequency communication)

Dimensions TKE and TKI

| Model | TKE 1,5 TKI 1,5 | TKE 6,0 TKI 6,0 | TKE 9,5 TKI 9,5 |
|-------|--------------------|--------------------|--------------------|
| A, mm | 193 | 226 | 246 |
| B, mm | 175 | 175 | 175 |
| C, mm | 49 | 59 | 80 |
| D, mm | 24 | 37 | 46 |
| E, mm | 44 | 58 | 74 |
| F, mm | 133 | 133 | 133 |
| G, mm | 104 | 104 | 104 |
| H, mm | 330 | 363 | 430 |
| J, mm | 153 | 170 | 180 |

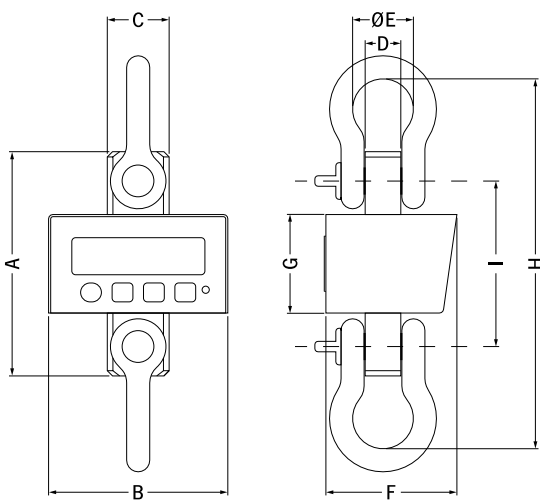



-TKR with digital display and radio control

The crane weigher can be operated by radio control. The displayed values can be taken off the remote control device and can be transferred to a PC. The system can be combined with an easy-to-read display. Several measured values can be totalled and saved.

Features

- TKR crane weigher has the same features like the model TKL plus:
- Remote control and data exchange via radio transmission.
- USB interface
- Accumulation memory

Option

- External easy-to-read display.

Scope of delivery

- Crane weigher
- Remote control with display
- 7 x 1.5V AA batteries
- Carrying case
- Test certificate
- PC cable
- User software



Crane weighers

Measuring range 0 - 12t

The crane weighers TKL and TKR are compact measuring devices for the weighing of loads. Use appropriate attachments like grade 8 forgings between the hook of the hoist or crane, the crane weigher and the load.

The crane weighers have a liquid crystal display (LCD), which can tare as well as show either the gross or the net load. It also indicates overload at 110% of the rated capacity and the status of the battery.

-TKL with digital display

Features

- High accuracy
- Lightweight design
- Easy-to-read display
- Easy to use
- Robust design
- Housing can be rotated 180°
- Retains the peak value to memory.
- The battery capacity provides for around 200 operating hours.
- Automatic setting to zero when load indicator is switched on.
- Use of rechargeable batteries possible (external battery charger*).
- Display of maximum weight (gross/net).
- Display of measuring units on the load indicator.
- Measuring units kg, t, lbs, to, kN.
- Automatic stand-by for a prolonged battery lifetime.
- Simple change of batteries
- Warning if batteries are low
- Overload warning

Scope of delivery

- Crane weigher
- 4 x 1.5V AA batteries
- Carrying case
- Test certificate

* not part of the delivery package.

Technical data TKL and TKR

| Model | TKL 1,0 | TKL 2,0 | TKL 3,2 | – TKR 5,0 | – TKR 8,0 | – TKR 12,0 |
|---|--|-----------|-----------|--------------|--------------|---------------|
| Art.-No. TKL | N53908446 | N53908448 | N53908451 | – | – | – |
| Art.-No. TKR | – | – | – | N53908454 | N53908456 | N53908458 |
| Measuring range, t | 0 - 1.0 | 0 - 2.0 | 0 - 3.2 | 0 - 5.0 | 0 - 8.0 | 0 - 12.0 |
| Limit load, t | 1.0 | 2.0 | 3.2 | 5.0 | 8.0 | 12.0 |
| Breaking load, t | 1.1 | 2.2 | 3.5 | 5.5 | 8.8 | 13.2 |
| Breaking load, t | ≥4.0 | ≥8.0 | ≥13.0 | ≥20.0 | ≥32.0 | ≥48.0 |
| Weight without lifting accessories, kg | 1.85 | 1.99 | 2.5 | 2.7 | 3.6 | 3.9 |
| Weight with lifting accessories, kg | 3.0 | 3.5 | 6.0 | 7.5 | 10.5 | 20.0 |
| Accuracy of the end value | 0.1% | 0.1% | 0.1% | 0.1% | 0.1% | 0.1% |
| Resolution step, kg (partition) | 0.5 | 1.0 | 1.0 | 1.0 | 2.0 | 5.0 |
| Operation time, approx., h ¹ | 200 | | | | | |
| Temperature range (operation) | -10 °C up to +50 °C | | | | | |
| Temperature range (storage) | -20 °C up to +70 °C | | | | | |
| Protection | IP 54 | | | | | |
| Display (LCD 20.5mm high) | 4 ½ digits | | | | | |
| Tare range | 100% of rated capacity | | | | | |
| Overload warning | Overload warning at 110% of the rated capacity | | | | | |

¹with 4 x 1.5V AA batteries

Dimensions TKL and TKR

| Model | TKL 1,0 | TKL 2,0 | TKL 3,2 | – TKR 5,0 | – TKR 8,0 | – TKR 12,0 |
|-------|---------|---------|---------|--------------|--------------|---------------|
| A, mm | 389 | 417 | 488 | 571 | 657 | 804 |
| B, mm | 356 | 379 | 441 | 514 | 588 | 709 |
| C, mm | 60 | 60 | 75 | 90 | 100 | 140 |
| D, mm | 110 | 110 | 135 | 160 | 180 | 260 |
| E, mm | 13 | 16 | 18 | 22 | 26 | 35 |
| F, mm | 20 | 25 | 32 | 40 | 49 | 45 |
| G, mm | 70 | 81 | 103 | 126 | 152 | 190 |
| H, mm | 128 | 136 | 140 | 148 | 158 | 176 |
| J, mm | 77.4 | 77.4 | 84.4 | 84.4 | 97.4 | 97.4 |

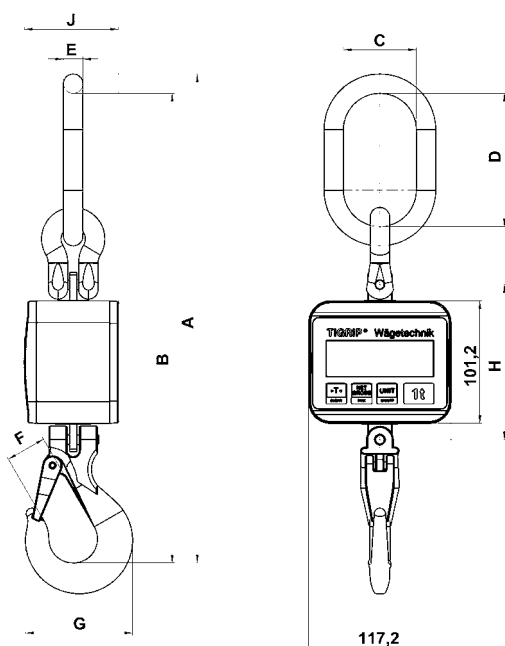



- TZR with digital display and radio control

The load indicator can be operated via radio control. The displayed values can be taken off the remote control device and can be transmitted to a PC. The system can be combined with an easy-to-read display. Several measured values can be totalled and saved.

Features

- TZR load indicator has the same features like the model TZL plus:
- Remote control and data exchange via radio transmission.
- USB interface
- Accumulation memory

Option

- External easy-to-read display.

Scope of delivery

- Load indicator
- Remote control with display
- 7 x 1.5V AA batteries
- Carrying case
- Test certificate
- Without shackles and hooks
- PC cable
- User software

Load indicator

Measuring range 0 - 100 t

The Tigrip® load indicator is a mechanical measuring instrument with electronic display. On account of its flexibility the Tigrip® load indicator has universal applications. Whether used as a conventional crane weigher or to measure forces, it is the economical choice for various applications. It can be used in conjunction with shackles and hooks.

The load indicator is provided with liquid crystal display (LCD), which can tare as well as show either the gross or the net load. It also indicates overload at 110% of the rated capacity and the status of the battery).

- TZL with digital display

Features

- High accuracy
- Lightweight design
- Easy-to-read display
- Easy to use
- Robust design
- Retains the peak value to memory.
- The battery capacity provides for around 200 operating hours.
- Automatic setting to zero when load indicator is switched on.
- Use of rechargeable batteries possible (external battery charger*).
- Display of maximum weight (gross/net).
- Display of measuring units on the load indicator.
- Measuring units kg, t, lbs, to, kN.
- Automatic stand-by for a prolonged battery lifetime.
- Simple change of batteries
- Warning if batteries are low.
- Overload warning

Scope of delivery

- Load indicator
- 4 x 1.5V AA batteries
- Carrying case
- Test certificate
- Without shackles and hooks

* not part of the delivery package.



Technical data TZL and TZR

| Model | TZL 2,5 - | TZL 5,0 - | TZL 10,0 TZR 10,0 | TZL 20,0 TZR 20,0 | - TZR 35,0 | - TZR 50,0 | - TZR 100,0 |
|---|--|--------------|----------------------|----------------------|---------------|---------------|----------------|
| Art.-No. TZL | N53808324 | N53808325 | N53808326 | N53808327 | - | - | - |
| Art.-No. TZL shackles | CM851A | N42000064 | N42000069 | N42000069 | - | - | - |
| Art.-No. TZL hooks | N53818351 | N53818352 | N53818322 | N53818324 | - | - | - |
| Art.-No. TZR | - | - | N53808333 | N53808335 | N53808336 | N53808337 | N53808338 |
| Art.-No. TZR shackles | - | - | N42000069 | N42000069 | N42000071 | N42000072 | N42000075 |
| Art.-No. TZR hooks | - | - | N53818322 | N53818324 | N53818326 | N53818328 | N53818330 |
| Measuring range, t | 0 - 2.5 | 0 - 5.0 | 0 - 10,0 | 0 - 20,0 | 0 - 35,0 | 0 - 50,0 | 0 - 100,0 |
| Limit load, t | 2.5 | 5.0 | 10.0 | 20.0 | 35.0 | 50.0 | 100.0 |
| Breaking load, t | 2.75 | 5.5 | 11 | 22 | 38.5 | 55 | 110 |
| Breaking load, t | ≥ 10 | ≥ 20 | ≥ 40 | ≥ 80 | ≥ 140 | ≥ 200 | ≥ 400 |
| Weight without lifting accessories, kg | 1.7 | 2.1 | 3.9 | 6.8 | 9.4 | 14.4 | 39.3 |
| Accuracy of the end value | 0.2% | 0.2% | 0.2% | 0.2% | 0.2% | 0.2% | 0.2% |
| Resolution step, kg (partition) | 1 | 1 | 10 | 10 | 10 | 10 | 50 |
| Operation time, approx., h ¹ | 200 | | | | | | |
| Temperature range (operation) | -10 °C up to +50 °C | | | | | | |
| Temperature range (storage) | -20 °C up to +70 °C | | | | | | |
| Protection | IP 54 | | | | | | |
| Display (LCD 20.5 mm high) | 4½ digits | | | | | | |
| Tare range | 100% of rated capacity | | | | | | |
| Overload warning | Overload warning at 110% of the rated capacity | | | | | | |

¹with 4 x 1.5V AA batteries

Dimensions TZL and TZR

| Model | TZL 2,5 - | TZL 5,0 - | TZL 10,0 TZR 10,0 | TZL 20,0 TZR 20,0 | - TZR 35,0 | - TZR 50,0 | - TZR 100,0 |
|-------|--------------|--------------|----------------------|----------------------|---------------|---------------|----------------|
| A, mm | 233 | 250 | 325 | 378 | 405 | 450 | 640 |
| B, mm | 118 | 118 | 118 | 141 | 156 | 180 | 260 |
| C, mm | 22 | 27 | 48 | 55 | 66 | 76 | 100 |
| D, mm | 173 | 180 | 213 | 233 | 245 | 264 | 380 |
| E, mm | 19 | 21.5 | 22 | 32 | 47 | 55 | 80 |
| G, mm | 25 | 30.5 | 47 | 57 | 67 | 77 | 99 |
| H, mm | 42.2 | 45.1 | 64.4 | 74.2 | 84.2 | 94.2 | 113 |
| J, mm | 604 | 610 | 690 | 780 | 1000 | 1170 | - |
| K, mm | 34 | 50 | 105 | 92 | 130 | 140 | 300 |
| L, mm | 38 | 44 | 95 | 95 | 114 | 132 | 238 |
| M, mm | 16 | 19 | 35 | 35 | 44 | 51 | 89 |
| N, mm | 25 | 32 | 50 | 70 | 110 | 115 | - |
| O, mm | 23 | 37 | 63 | 80 | 123 | 132 | - |
| P, mm | 17 | 28 | 44 | 57 | 90 | 97 | - |
| Q, mm | 309 | 315 | 535 | 562 | 665 | 730 | 1240 |

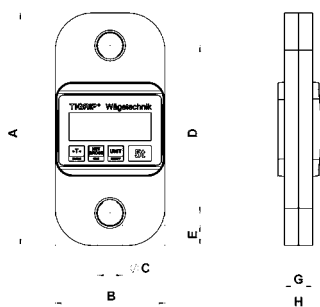

Load indicator TZL/TZR 2.5 up to 100.0t

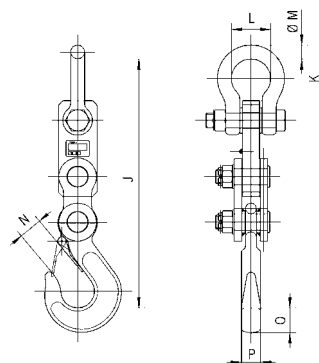

Load indicator TZL/TZR with hook

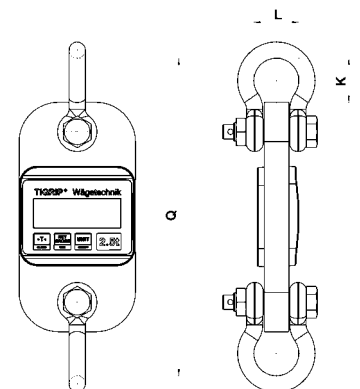

Load indicator TZL/TZR with shackle



YFS
Spring tensioners

Capacity 0.5 - 10.0 kg

YFS-A
Spring tensioners with ratchet locking device

Capacity 2 - 10.0 kg

Spring tensioners are designed to retract the cable when no force is applied. An amount of downward force must be continually applied to keep the suspended object at its extended position.

The torque output of the rewind spring increases as the cable is extended, retracting the suspended object to the uppermost adjusted position when released.

Features

- Stamped steel construction, powder-coated housing.
- Automatic drumlock according to DIN 15112.
- Additional hanger for the attachment of secondary safety chains according to DIN 15112.
- Rope guide made of wear-resistant nylon for reduced wear of rope and body.
- Declaration of EC-conformity.
- Adjustable cable stop to fix the spring tensioner in the desired position.
- Series YFS-A with ratchet-locking device. Locks the out-retracting rope for unrestricted tool movement. This device can be switched ON/OFF, so the spring tensioner can be used with or without the ratchet-locking device.

Applications

Pneumatic power-tools, assembly tools, paint spraying guns, riveting machines, nut runners, grinding and polishing machines.



Adjustment of spring tension YFS-01/02 with central turning wheel and spring lever



Adjustment of spring tension YFS-03/04/05 with central shaft and spring lever

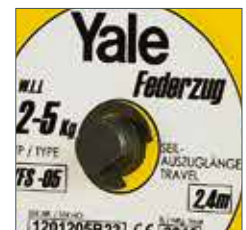

Technical data YFS and YFS-A

| Model | Art.-No. | Capacity min. kg | Capacity max. kg | Working range m | Weight kg |
|----------|-----------|------------------|------------------|-----------------|-----------|
| YFS-01 | N08300047 | 0.5 | 1.5 | 1.6 | 0.35 |
| YFS-02 | N08300048 | 1.5 | 3.0 | 1.5 | 0.35 |
| YFS-03 | N08300049 | 2.0 | 5.0 | 2.4 | 3.9 |
| YFS-04 | N08300050 | 4.0 | 6.0 | 2.4 | 4.5 |
| YFS-05 | N08300051 | 6.0 | 10.0 | 2.4 | 4.5 |
| YFS-03-A | N08300052 | 2.0 | 5.0 | 2.4 | 3.9 |
| YFS-04-A | N08300053 | 4.0 | 6.0 | 2.4 | 4.5 |
| YFS-05-A | N08300054 | 6.0 | 10.0 | 2.4 | 4.5 |

Dimensions YFS and YFS-A

| Model | YFS-01 | YFS-02 | YFS-03 | YFS-04 | YFS-05 | YFS-03-A | YFS-04-A | YFS-05-A |
|---------|--------|--------|--------|--------|--------|----------|----------|----------|
| A, mm | 231 | 231 | 423 | 423 | 423 | 423 | 423 | 423 |
| B, mm | 224 | 224 | 214 | 214 | 214 | 214 | 214 | 214 |
| C, mm | 97 | 97 | 191 | 191 | 191 | 191 | 191 | 191 |
| Ø D, mm | 12 | 12 | 19 | 19 | 19 | 19 | 19 | 19 |
| E, mm | 48 | 48 | 79 | 79 | 79 | 91 | 91 | 91 |
| F, mm | 25 | 25 | 43 | 43 | 43 | 55 | 55 | 55 |
| G, mm | - | - | 71 | 71 | 71 | 71 | 71 | 71 |
| H, mm | 39 | 39 | 80 | 80 | 80 | 80 | 80 | 80 |

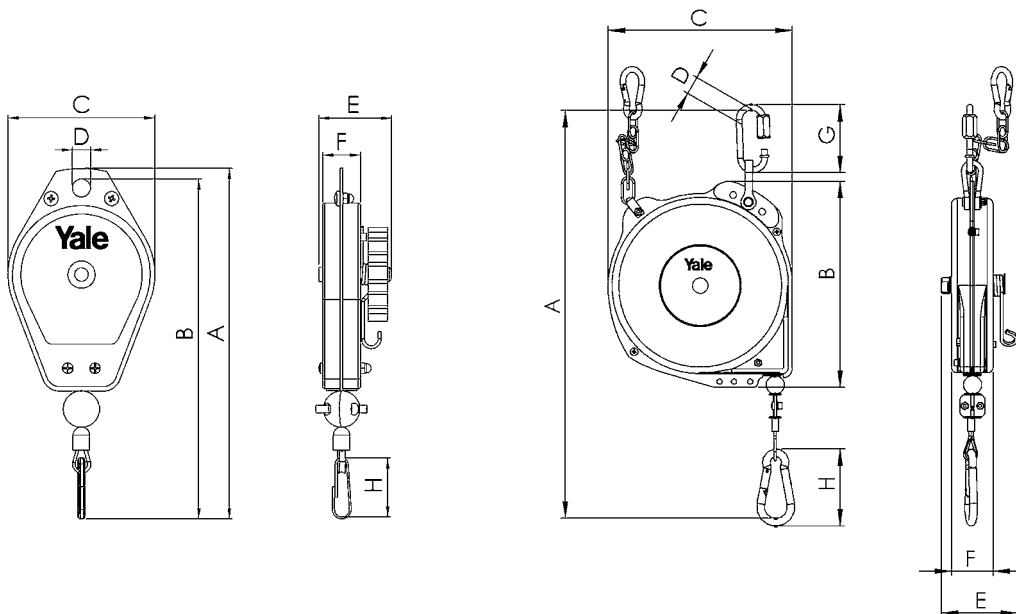

Spring Balancers



INFO

Capacities up to 300 kg available on request.



Load indicator

for
YBF-09 up to YBF-70
YBF-22L up to YBF-70L
YBA-15 up to YBA-70
YBA-22L up to YBA-70L



Rope guide

for
YBF-09 up to YBF-200
YBF-09L up to YBF-130L
YBA-15 up to YBA-70



Spring assembly

as separate unit in a closed steel housing.
All models with capacities more than 5 kg.

YBF

Spring balancers

Capacity 0.5 - 200 kg

YBF-L

Spring balancers with extended rope length

Capacity 1.5 - 130 kg

Spring balancers are used to relieve the operator from the weight of hand-tools. By using a tapered rope drum the weight of the attached load is compensated, loads up to 200 kg can be moved effortlessly in vertical axis.

Features

- Spring balancers model YBF are designed in accordance with DIN 15112.
- The housing is manufactured from high-tensile aluminium pressure die casting for maximum resistance to impact.
- Manual drum lock for an easy exchange of rope or for changing the attached load.
- The special spring-assembly inside the balancer guarantees a consistent counterbalance throughout the complete working range.
- Easy exchange of wire rope. A small slot in the body facilitates the removal and re-installation of the rope without any need to disassemble the unit.
- Spring assemblies as separate units in a closed steel housing for improved handling during assembly and disassembly. Reduced risk of injuries.
- Rope guide made of wear-resistant nylon for reduced wear of rope and body. Lifetime of the spring balancer is increased. The rope guide can be removed and installed on site without disassembling the rope.
- Load indicator allows easy reading of the capacity set.
- Upper and lower suspension eyes are provided for the attachment of secondary safety chains. Providing additional safety and preventing the spring balancer and load from falling accidentally.

Applications

Spot-welding guns, riveting-machines, slaughterhouse equipment, multiple nut-runners etc.

Spring Balancers

YBA

Spring balancers with safety feature in case of rope breakage

Capacity 9 - 70 kg

YBA-L

Spring balancers with safety feature in case of rope breakage and with extended rope length

Capacity 9 - 70 kg

YBA series spring balancers have the same technical features as the YBF series, but are equipped with an additional safety feature in case of rope breakage.

This mechanism automatically locks the rope in case of accidental dislodging of the suspended weight, breakage of the bottom hook or the rope.

Whipping of the rope and potential injuries to the operator or other personnel in the area is avoided.

This series is used primarily in areas in which higher safety standards are applied or adverse conditions are common (flying sparks etc.) which might cause damages to the rope.

This series is available with standard and extended rope length.



Suspension eye
according DIN 15112 spring balancers must be equipped with additional suspension eyes for the attachment of secondary safety chains.



Easy exchange of wire rope
without any need to disassemble the unit.
YBF-09 up to YBF-100
YBA-15 up to YBA-70



Manual drum-lock
for an easy exchange of the rope. All models with capacity more than 5 kg.

Spring Balancers

Technical data YBF and YBF-L

| Model | Suspension eyes top (T) and bottom (B) | Adjustment of spring tension V=vertical H=horizontal | Tapered rope drum | Manual drum lock | Automatic drum-locking device | Load indicator | Spring assembly enclosed | Closed body | Rope guide, nylon | Rope exchange without disassembly |
|----------|--|--|-------------------|------------------|-------------------------------|----------------|--------------------------|-------------|-------------------|-----------------------------------|
| YBF-01 | 0 | H | • | – | – | – | – | • | – | – |
| YBF-02 | 0 | H | • | – | – | – | – | • | – | – |
| YBF-03 | 0 | H | • | – | – | – | – | • | – | – |
| YBF-05 | 0 | H | • | – | – | – | – | • | – | – |
| YBF-09 | 0 | H | • | • | • | • | • | • | • | • |
| YBF-15 | 0 | H | • | • | • | • | • | • | • | • |
| YBF-22 | 0 + U | V | • | • | • | • | • | • | • | • |
| YBF-30 | 0 + U | V | • | • | • | • | • | • | • | • |
| YBF-40 | 0 + U | V | • | • | • | • | • | • | • | • |
| YBF-50 | 0 + U | V | • | • | • | • | • | • | • | • |
| YBF-60 | 0 + U | V | • | • | • | • | • | • | • | • |
| YBF-70 | 0 + U | V | • | • | • | • | • | • | • | • |
| YBF-85 | 0 + U | V | • | • | • | – | • | • | • | • |
| YBF-100 | 0 + U | V | • | • | • | – | • | • | • | • |
| YBF-120 | 0 | H | • | • | • | – | • | • | • | – |
| YBF-140 | 0 | H | • | • | • | – | • | • | • | – |
| YBF-170 | 0 | H | • | • | • | – | • | • | • | – |
| YBF-200 | 0 | H | • | • | • | – | • | • | • | – |
| YBF-03L | 0 | H | • | – | • | – | – | • | – | – |
| YBF-05L | 0 | H | • | – | • | – | – | • | – | – |
| YBF-09L | 0 | V | • | • | • | – | • | • | • | – |
| YBF-15L | 0 | V | • | • | • | – | • | • | • | – |
| YBF-22L | 0 | V | • | • | • | • | • | • | • | – |
| YBF-30L | 0 | V | • | • | • | • | • | • | • | – |
| YBF-40L | 0 + U | V | • | • | • | • | • | • | • | – |
| YBF-50L | 0 + U | V | • | • | • | • | • | • | • | – |
| YBF-60L | 0 + U | V | • | • | • | • | • | • | • | – |
| YBF-70L | 0 + U | V | • | • | • | • | • | • | • | – |
| YBF-85L | 0 + U | V | • | • | • | – | • | • | • | – |
| YBF-100L | 0 | H | • | • | • | – | • | • | • | – |
| YBF-120L | 0 | H | • | • | • | – | • | • | • | – |
| YBF-130L | 0 | H | • | • | • | – | • | • | • | – |

Technical data YBA and YBA-L

| Model | Suspension eyes top (T) and bottom (B) | Adjustment of spring tension V=vertical H=horizontal | Tapered rope drum | Manual drum lock | Automatic drum-locking device | Load indicator | Spring assembly enclosed | Closed body | Rope guide, nylon | Rope exchange without disassembly |
|---------|--|--|-------------------|------------------|-------------------------------|----------------|--------------------------|-------------|-------------------|-----------------------------------|
| YBA-15 | 0 | V | • | • | • | • | • | • | • | • |
| YBA-22 | 0 + U | V | • | • | • | • | • | • | • | • |
| YBA-30 | 0 + U | V | • | • | • | • | • | • | • | • |
| YBA-40 | 0 + U | V | • | • | • | • | • | • | • | • |
| YBA-50 | 0 + U | V | • | • | • | • | • | • | • | • |
| YBA-60 | 0 + U | V | • | • | • | • | • | • | • | • |
| YBA-70 | 0 + U | V | • | • | • | • | • | • | • | • |
| YBA-15L | 0 + U | V | • | • | • | – | • | • | • | – |
| YBA-22L | 0 + U | V | • | • | • | • | • | • | • | – |
| YBA-30L | 0 + U | V | • | • | • | • | • | • | • | – |
| YBA-40L | 0 + U | V | • | • | • | • | • | • | • | – |
| YBA-50L | 0 + U | V | • | • | • | • | • | • | • | – |
| YBA-60L | 0 + U | V | • | • | • | • | • | • | • | – |
| YBA-70L | 0 + U | V | • | • | • | • | • | • | • | – |

Spring Balancers

Technical data YBF and YBF-L

| Model | Art.-No. | Capacity min. | Capacity max. | Working range | Weight with rope |
|----------|-----------|---------------|---------------|---------------|------------------|
| | | kg | kg | m | kg |
| YBF-01 | N08300001 | 0.5 | 1.5 | 1.0 | 1.0 |
| YBF-02 | N08300002 | 1 | 2 | 1.0 | 1.0 |
| YBF-03 | N08300003 | 1.5 | 3 | 1.3 | 1.8 |
| YBF-05 | N08300004 | 3 | 5 | 1.3 | 1.9 |
| YBF-09 | N08300007 | 4.5 | 9 | 1.3 | 4.0 |
| YBF-15 | N08300008 | 9 | 15 | 1.3 | 4.0 |
| YBF-22 | N08300009 | 15 | 22 | 1.5 | 8.0 |
| YBF-30 | N08300010 | 22 | 30 | 1.5 | 8.0 |
| YBF-40 | N08300011 | 30 | 40 | 1.5 | 10.5 |
| YBF-50 | N08300012 | 40 | 50 | 1.5 | 10.5 |
| YBF-60 | N08300013 | 50 | 60 | 1.5 | 11.0 |
| YBF-70 | N08300014 | 60 | 70 | 1.5 | 11.5 |
| YBF-85 | N08300015 | 70 | 85 | 1.5 | 12.0 |
| YBF-100 | N08300016 | 85 | 100 | 1.5 | 12.5 |
| YBF-120 | N08300017 | 100 | 120 | 1.5 | 28.0 |
| YBF-140 | N08300018 | 120 | 140 | 1.5 | 29.0 |
| YBF-170 | N08300019 | 140 | 170 | 1.5 | 35.0 |
| YBF-200 | N08300020 | 170 | 200 | 1.5 | 36.0 |
| YBF-03L | N08300005 | 1.5 | 3 | 2.5 | 3.9 |
| YBF-05L | N08300006 | 3 | 5 | 2.5 | 4.0 |
| YBF-09L | N08300021 | 4.5 | 9 | 2.3 | 7.0 |
| YBF-15L | N08300022 | 9 | 15 | 2.3 | 7.5 |
| YBF-22L | N08300023 | 15 | 22 | 2.3 | 8.5 |
| YBF-30L | N08300024 | 22 | 30 | 2.3 | 8.5 |
| YBF-40L | N08300025 | 30 | 40 | 2.3 | 11.0 |
| YBF-50L | N08300026 | 40 | 50 | 2.3 | 11.0 |
| YBF-60L | N08300027 | 50 | 60 | 2.3 | 11.5 |
| YBF-70L | N08300028 | 60 | 70 | 2.3 | 12.0 |
| YBF-85L | N08300029 | 70 | 85 | 2.5 | 26.5 |
| YBF-100L | N08300030 | 85 | 100 | 2.5 | 27.0 |
| YBF-120L | N08300031 | 100 | 120 | 2.5 | 34.0 |
| YBF-130L | N08300032 | 120 | 130 | 2.5 | 35.0 |



Technical data YBA and YBA-L

| Model | Art.-No. | Capacity min. | Capacity max. | Working range | Weight with rope |
|---------|-----------|---------------|---------------|---------------|------------------|
| | | kg | kg | m | kg |
| YBA-15 | N08300033 | 9 | 15 | 1.3 | 5.5 |
| YBA-22 | N08300034 | 15 | 22 | 1.5 | 8.5 |
| YBA-30 | N08300035 | 22 | 30 | 1.5 | 9.0 |
| YBA-40 | N08300036 | 30 | 40 | 1.5 | 11.5 |
| YBA-50 | N08300037 | 40 | 50 | 1.5 | 12.0 |
| YBA-60 | N08300038 | 50 | 60 | 1.5 | 13.0 |
| YBA-70 | N08300039 | 60 | 70 | 1.5 | 13.5 |
| YBA-15L | N08300040 | 9 | 15 | 2.3 | 8.5 |
| YBA-22L | N08300041 | 15 | 22 | 2.3 | 9.0 |
| YBA-30L | N08300042 | 22 | 30 | 2.3 | 9.5 |
| YBA-40L | N08300043 | 30 | 40 | 2.3 | 12.0 |
| YBA-50L | N08300044 | 40 | 50 | 2.3 | 12.5 |
| YBA-60L | N08300045 | 50 | 60 | 2.3 | 13.5 |
| YBA-70L | N08300046 | 60 | 70 | 2.3 | 14.0 |

Spring Balancers

Dimensions spring balancers body type I, body type II & body type III

| Model | Body type I | | Body type II | | | Body type III | | | | | |
|------------|------------------|------------------|------------------|--------------------|--------|------------------|------------------|---------------------------------------|--|--------------------|--------------------|
| | YBF-01 YBF-02 | YBF-03 YBF-05 | YBF-09 YBF-15 | YBF-03L YBF-05L | YBA-15 | YBF-22 YBF-30 | YBF-40 YBF-50 | YBF-60 YBF-70 YBF-85 YBF-100 | YBF-09L YBF-15L YBF-22L YBF-30L | YBF-40L YBF-50L | YBF-60L YBF-70L |
| A min., mm | 315 | 290 | 340 | 375 | 340 | 445 | 440 | 440 | 445 | 440 | 440 |
| A max., mm | 1315 | 1590 | 1640 | 2875 | 1640 | 1945 | 1940 | 1940 | 2745 | 2740 | 2740 |
| B, mm | 132 | 148 | 174 | 197 | 174 | 218 | 220 | 220 | 218 | 220 | 220 |
| C, mm | 72 | 89 | 109 | 114 | 109 | 130 | 130 | 130 | 130 | 130 | 130 |
| D, mm | 68 | 78 | 95 | 105 | 95 | 111 | 111 | 111 | 111 | 111 | 111 |
| E, mm | 120 | 120 | 152 | 175 | 152 | 194 | 194 | 194 | 194 | 194 | 194 |
| F, mm | 22 | 25 | 15 | 23 | 15 | 35 | 35 | 35 | 35 | 35 | 35 |
| G, mm | 26 | 33 | 38 | 30 | 38 | 47 | 47 | 47 | 47 | 47 | 47 |
| H, mm | 10 | 10 | 12 | 12 | 12 | 15 | 17 | 17 | 15 | 17 | 17 |
| I, mm | 14 | 14 | 24 | 14 | 24 | 30 | 30 | 30 | 30 | 30 | 30 |
| J, mm | 9 | 9 | 14 | 14 | 14 | 18 | 18 | 18 | 18 | 18 | 18 |
| K, mm | 10 | 8 | 15 | 14 | 15 | 18 | 18 | 18 | 18 | 18 | 18 |
| L, mm | 17 | 14 | 18 | 17 | 18 | 24 | 24 | 24 | 24 | 24 | 24 |
| M min., mm | 45 | 45 | 39 | 65 | 39 | 46 | 46 | 46 | 46 | 46 | 46 |
| M max., mm | 65 | 75 | 68 | 105 | 68 | 83 | 83 | 83 | 83 | 83 | 83 |
| N, mm | 9 | 9 | 14 | 14 | 14 | 16 | 16 | 16 | 16 | 16 | 16 |
| O, mm | 6 | 6 | 9 | 8 | 9 | 12 | 14 | 14 | 12 | 14 | 14 |
| P, mm | 11 | 12 | 24 | 30 | 24 | 35 | 75 | 86 | 35 | 75 | 86 |
| Q, mm | 5 | 9 | 25 | 9 | 25 | 30 | 33 | 33 | 30 | 33 | 33 |
| R, mm | 30 | 32 | 72 | 45 | 94 | 80 | 105 | 116 | 80 | 105 | 116 |
| S min., mm | 20 | 35 | 65 | 55 | 87 | 72 | 97 | 97 | 72 | 97 | 97 |
| S max., mm | 38 | 50 | 99 | 85 | 121 | 112 | 137 | 137 | 112 | 137 | 137 |
| T, mm | 49 | 69 | 136 | 110 | 148 | 158 | 188 | 199 | 158 | 188 | 199 |
| U, mm | - | - | - | - | - | 130 | 130 | 130 | 130 | 130 | 130 |

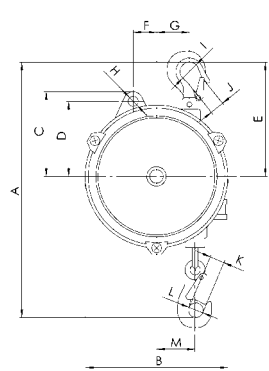

Body type I

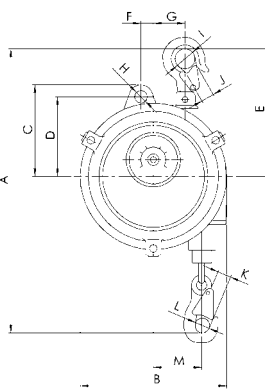
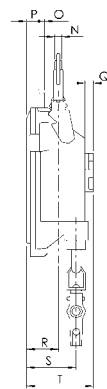

Body type II

Dimensions spring balancers body type IV & body type V

| Model | Body type IV | | | | Body type V | | | | | |
|------------|--------------------|--------------------|---------------------|----------------------|------------------|------------------|------------------|-------------------------------|--------------------|--------------------|
| | YBF-120 YBF-140 | YBF-170 YBF-200 | YBF-85L YBF-100L | YBF-120L YBF-130L | YBA-22 YBA-30 | YBA-40 YBA-50 | YBA-60 YBA-70 | YBA-15L YBA-22L YBA-30L | YBA-40L YBA-50L | YBA-60L YBA-70L |
| A min., mm | 550 | 550 | 550 | 550 | 445 | 440 | 440 | 445 | 440 | 440 |
| A max., mm | 2050 | 2050 | 3050 | 3050 | 1945 | 1940 | 1940 | 2745 | 2740 | 2740 |
| B, mm | 247 | 247 | 247 | 247 | 218 | 220 | 220 | 218 | 220 | 220 |
| C, mm | 156 | 156 | 156 | 156 | 130 | 130 | 130 | 130 | 130 | 130 |
| D, mm | 128 | 128 | 128 | 128 | 111 | 111 | 111 | 111 | 111 | 111 |
| E, mm | 265 | 265 | 265 | 265 | 194 | 194 | 194 | 194 | 194 | 194 |
| F, mm | 40 | 40 | 40 | 40 | 35 | 35 | 35 | 35 | 35 | 35 |
| G, mm | 65 | 65 | 65 | 65 | 47 | 47 | 47 | 47 | 47 | 47 |
| H, mm | 17 | 17 | 17 | 17 | 15 | 17 | 17 | 15 | 17 | 17 |
| I, mm | 26 | 26 | 26 | 26 | 30 | 30 | 30 | 30 | 30 | 30 |
| J, mm | 15 | 15 | 15 | 15 | 18 | 18 | 18 | 18 | 18 | 18 |
| K, mm | 24 | 24 | 24 | 24 | 18 | 18 | 18 | 18 | 18 | 18 |
| L, mm | 27 | 27 | 27 | 27 | 24 | 24 | 24 | 24 | 24 | 24 |
| M min., mm | 54 | 54 | 54 | 54 | 46 | 46 | 46 | 46 | 46 | 46 |
| M max., mm | 95 | 95 | 95 | 95 | 83 | 83 | 83 | 83 | 83 | 83 |
| N, mm | 18 | 18 | 18 | 18 | 16 | 16 | 16 | 16 | 16 | 16 |
| O, mm | 16 | 16 | 16 | 16 | 12 | 14 | 14 | 12 | 14 | 14 |
| P, mm | 142 | 185 | 142 | 185 | 55 | 95 | 105 | 55 | 95 | 105 |
| Q, mm | 37 | 37 | 37 | 37 | 30 | 33 | 33 | 30 | 33 | 33 |
| R, mm | 155 | 193 | 155 | 193 | 115 | 140 | 140 | 115 | 140 | 140 |
| S min., mm | 175 | 215 | 175 | 215 | 107 | 132 | 132 | 107 | 132 | 132 |
| S max., mm | 205 | 248 | 205 | 248 | 147 | 172 | 172 | 147 | 172 | 172 |
| T, mm | 268 | 268 | 268 | 310 | 180 | 208 | 218 | 180 | 208 | 218 |
| U, mm | 156 | 156 | 156 | 156 | 130 | 130 | 130 | 130 | 130 | 130 |

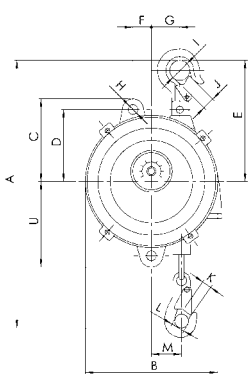

Body type III
Body type V

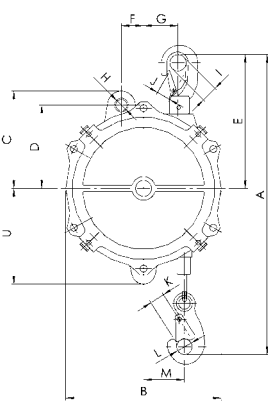
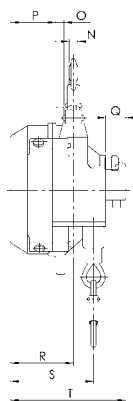

Body type IV

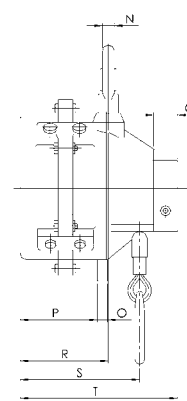

INFO

Yale hoists and trolleys are not designed for passenger elevation applications and must not be used for this purpose.

Textile Lifting Slings

Yale webbing slings and round slings are produced from high-tensile quality polyester (PES) in accordance with EN 1492, parts 1 and 2. The highly flexible and versatile material exerts evenly distributed pressure on pressure-sensitive and tension-sensitive loads; it is not subject to material ageing or brittleness and is heat-resistant up to +100 °C.

Lashing Systems

Yale lashing belts are produced from polyester (PES) according to EN 12195-2. The extremely resilient belt material is resistant to stretching and abrasion; it guarantees a high load bearing capacity and a long service life. All Yale lashing belts are stretched belts, thermally fixed and protected against abrasion.

INFO

Please note our user instructions at the beginning of each chapter.

Table of contents

| | Page |
|------------------------------------|-----------|
| Round slings | 234 - 239 |
| Round sling assembly | 239 - 241 |
| Webbing slings | 242 - 246 |
| Textile lifting slings accessories | 247 - 250 |

| | Page |
|-----------------------------|-----------|
| Trucker Set | 251 |
| Textile lashings | 256 - 263 |
| Special textile lashings | 263 |
| Lashing systems accessories | 264 - 267 |

Yale

TEXTILE LIFTING SLINGS



OFFER

This user information presents a general overview regarding the application of textile lifting slings and does not substitute the existing operating instructions for specific products!

Lifting operations with textile slings may be carried out by competent users (trained in theory and practice) only.

When operated correctly, our textile slings offer the highest degree of safety in line with long life expectancy and avoid damage to products and people.

Limitations of use

Loading

Textile lifting slings must not be overloaded. The capacities for the most important lifting/sliding methods are indicated on the identity label. Always observe the maximum angle from the vertical (angle β)!

Temperature

Textile lifting slings made from polyester are admitted for applications at temperatures between $-40\text{ }^{\circ}\text{C}$ and $+100\text{ }^{\circ}\text{C}$. This temperature area may change in chemical environments. The woven structure of the drenched textiles at temperatures below $0\text{ }^{\circ}\text{C}$ are susceptible to damage due to the formation of ice.

Ice will reduce the flexibility of the lifting sling! At temperatures below $0\text{ }^{\circ}\text{C}$, dry lifting equipment should be used only! In dry condition, polyester features a high electrical resistance and provides an insulating effect between load and crane hook (e.g. during welding jobs – observe temperatures!).

Shock loading

Textile lifting and lashing equipment should not be subjected to sharp jerks and jolts in order to avoid heavy forces which may be considerably higher than the actual load weight!

Chemicals

Particular caution is required when using textile lifting equipment in areas where chemicals are present. Polyester has good resistance against mineral acids but will be destroyed by alkaline – consult our experts for advice in your specific application!

Acid may cause material brittleness to steel fittings of textile lifting slings! Harmless acid solutions may concentrate by evaporation to an extent that they provoke damages. Affected textile lifting equipment must be thoroughly rinsed in cold water, dried in open air and inspected by a competent person.

Transport of people

Transport of people with textile lifting equipment is generally forbidden!

Operation in danger zones

Lifting or transport of loads must be avoided while personnel are in the danger zone.

People are not allowed to pass over or under a suspended load!

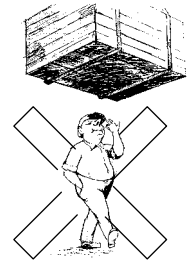

Application advices

- The operator may start moving the load only after it has been correctly attached and all personnel are clear of the danger zone.
- Loads must not be left unattended in raised or tensioned condition for a longer period of time.
- Flat webbing or round slings must not be used in knotted, tied or twisted condition and may only be used for the attachment of loads.
- Prior to every use, textile lifting and lashing equipment must be examined with regard to obvious defects. Ensure that their identity and dimensions are correct and that they are provided with a legible capacity label. Never use lifting equipment which is defective or not labelled!
- Damage of the capacity label can be avoided by keeping it away from the load, the hook or choke hitch operations!

- The angle of the eye must not exceed 20° in order to avoid inadmissible strain on the seams! This will be ensured when the eye length is approx. 4 times the width of the hook.

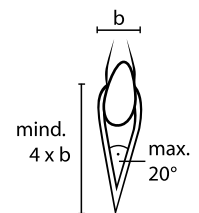

- Hooks or other lifting devices in loaded condition must not be attached in the area of sewn overlaps or at the seam of the round sling sleeve. Make sure that the seams are positioned in the straight part of the lifting device!

- Hooks should be provided with sufficient radius. The contact area of the web sling must be straight, so that the entire cross section of the sling is loaded equally. If the carrying width of flat webbing sling is below 75 mm, the radius curve of the lifting device must be at least $\frac{3}{4}$ of the width of the webbing sling.

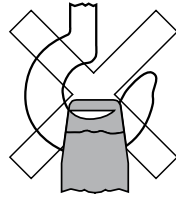

- Take care that round slings do not overlap in the crane hook. They must have sufficient space in the hook mouth as well as at the load, so they can assume their natural, flattened profile and provide even loading over the full width of the round sling.
- Flat webbing slings should be applied in such a way that they can carry the load over the full sling width. Greater angles from the vertical will strain the edges of the slings and possibly lead to breakage!
- Textile lashing equipment must be protected against sharp edges, friction and abrasion at both load and lifting device. A radius edge is classed as sharp, if it is less than the thickness of the flat webbing or round sling (in flat, loaded condition).
- Never push or place the load onto the lifting device! Never pull the load over rough surfaces or edges and do not drag from underneath a load!
- In "choke hitch" the textile sling should be positioned so that it can form a natural angle of 60° and that heat due to friction is avoided. Never re-adjust the choke hitch and prevent heat development by friction (slipping of load). In order to lift loads with plain or slippery surface we recommend double choke hitch.

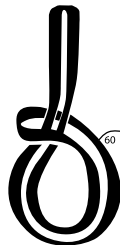

- Round slings and flat webbing slings will stretch under load by approx. 3 - 5%. This has to be strictly considered as it may cause abrasion resp. damages at sensible surfaces. As prevention we recommend the use of protective sleeves and edge protectors. In case of (intended) load movements during lifting operations and resulting friction, e.g. during assembling or turning of goods, the surface or edges of the load must be secured by protective sleeves or corner protectors, which will safeguard the lashing device and leave sufficient space for movement and alignment without greater friction (see dim. B in the following drawing).

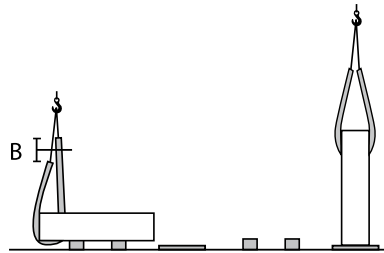

- If more than one sling is used to lift a load, these should be of same type with preferably same length in order to avoid different elongation behaviour and allow carrying ability over the full width (employ smallest angle from the vertical or use spreader beam instead).
- Textile lifting equipment must be stored in a clean, dry and well ventilated area. Avoid exposure to direct sunlight and other sources of UV. Keep them away from other heat sources, chemicals, fumes and corroded surfaces as they will have a negative effect on the life expectancy of the sling. Slings should not be dried near open fires or other hot places.
- Textile slings with obvious damages, overloading or other detrimental influences must be taken out of use and may be returned to service after inspection and possible repair only.



Maintenance and repair

Inspections and tests must be performed by competent persons or specialist workshops only.

Inspections

Depending on application, textile lifting equipment must be subjected to regular inspections by competent persons, at least once per year. The inspection must be visual and extended to the following deficiencies:

- Complete and legible identity label.
- Damages by chemical influence, e.g. local soaking, chipping of yarns or heat (hardening).
- Steel links must not show deformations, grooves or reduction to the cross section of more than 10%. Check for cracks; possible welding points must be visible and not covered by the webbing.
- Inspections have to be recorded.
- Defective slings have to be taken out of service immediately and must be stored separately!

Criteria for disposal

Textile slings must not be used any longer if e.g.:

- The marking (identity label) is missing or illegible.
- Detrimental impacts have occurred, e.g. overloading, shock loading, chemical influence or heat.

Flat webbing slings:

- Damages of selvedge, defects of the woven structure by abrasion, cuts or yarn breakages have occurred. If 10% or more of the webbing sling cross section is damaged the sling must be discarded.
- Heavy deformation or melting of yarns due to heat (shiny surface and/or hardened webbing) can be recognized.
- Load bearing seams are defective.

Round slings:

- The outside (sleeve) is damaged by cuts or abrasion.
- The inside (polyester yarns) of the sling is visible.
- The seams of the sleeve are damaged.

INFO

Yale hoists and trolleys are not designed for passenger elevation applications and must not be used for this purpose.

Webbing slings Rated capacities for different slinging methods

| Factor | | WLL (kg) with one webbing sling | | | | | WLL (kg) with two webbing slings | | | |
|----------|--|---------------------------------|-------------|----------------------|---------|----------|----------------------------------|----------|---------------------------|----------|
| | | straight pull | choke hitch | basket angle β | | | straight angle β | | choke hitch angle β | |
| | | | | up to 7° | 7°- 45° | 45°- 60° | 7°- 45° | 45°- 60° | 7°- 45° | 45°- 60° |
| | | | | | | | | | | |
| | | 1.0 | 0.8 | 2.0 | 1.4 | 1.0 | 1.4 | 1.0 | 1.12 | 0.8 |
| 1000 kg | | 1000 | 800 | 2000 | 1400 | 1000 | 1400 | 1000 | 1120 | 800 |
| 2000 kg | | 2000 | 1600 | 4000 | 2800 | 2000 | 2800 | 2000 | 2240 | 1600 |
| 3000 kg | | 3000 | 2400 | 6000 | 4200 | 3000 | 4200 | 3000 | 3360 | 2400 |
| 4000 kg | | 4000 | 3200 | 8000 | 5600 | 4000 | 5600 | 4000 | 4480 | 3200 |
| 5000 kg | | 5000 | 4000 | 10000 | 7000 | 5000 | 7000 | 5000 | 5600 | 4000 |
| 6000 kg | | 6000 | 4800 | 12000 | 8400 | 6000 | 8400 | 6000 | 6720 | 4800 |
| 8000 kg | | 8000 | 6400 | 16000 | 11200 | 8000 | 11200 | 8000 | 8960 | 6400 |
| 10000 kg | | 10000 | 8000 | 20000 | 14000 | 10000 | 14000 | 10000 | 11200 | 8000 |

Round slings Rated capacities for different slinging methods

| Factor | | WLL (kg) with one round sling | | | | | WLL (kg) with two round slings | | | | | |
|----------|--|-------------------------------|-------------|----------------------|---------|----------|--------------------------------|----------|---------------------------|----------|-------|------|
| | | straight pull | choke hitch | basket angle β | | | straight angle β | | choke hitch angle β | | | |
| | | | | up to 7° | 7°- 45° | 45°- 60° | 7°- 45° | 45°- 60° | 7°- 45° | 45°- 60° | | |
| | | | | | | | | | | | | |
| | | 1.0 | 0.8 | 2.0 | 1.4 | 1.0 | 0.7 | 0.5 | 1.4 | 1.0 | 1.12 | 0.8 |
| 1000 kg | | 1000 | 800 | 2000 | 1400 | 1000 | 700 | 500 | 1400 | 1000 | 1120 | 800 |
| 2000 kg | | 2000 | 1600 | 4000 | 2800 | 2000 | 1400 | 1000 | 2800 | 2000 | 2240 | 1600 |
| 3000 kg | | 3000 | 2400 | 6000 | 4200 | 3000 | 2100 | 1500 | 4200 | 3000 | 3360 | 2400 |
| 4000 kg | | 4000 | 3200 | 8000 | 5600 | 4000 | 2800 | 2000 | 5600 | 4000 | 4480 | 3200 |
| 5000 kg | | 5000 | 4000 | 10000 | 7000 | 5000 | 3500 | 2500 | 7000 | 5000 | 5600 | 4000 |
| 6000 kg | | 6000 | 4800 | 12000 | 8400 | 6000 | 4200 | 3000 | 8400 | 6000 | 6720 | 4800 |
| 8000 kg | | 8000 | 6400 | 16000 | 11200 | 8000 | 5600 | 4000 | 11200 | 8000 | 8960 | 6400 |
| 10000 kg | | 10000 | 8000 | 20000 | 14000 | 10000 | 7000 | 5000 | 14000 | 10000 | 11200 | 8000 |



RSD

Round sling with duplex sleeve

Made from polyester (PES), EN 1492-2 with double stitchless protection sleeve, with capacity label.

Features

- With double protection sleeve, PU-starched, thermally fixed.
- Colour coding of the protective sleeve.
- Printed-on capacities.
- Woven tonnage stripes, per ton capacity 1 stripe.
- Low weight allows easy handling.
- Protection against hand injuries.
- Protection against cargo surface damage.
- Highly flexible and adaptable to given shapes.
- UV-resistant, eliminating material ageing or embrittlement.
- Heat resistant up to +100 °C.
- Moisture-resistant fabric, thus preventing frost damage (up to approx. -40 °C).

INFO

Further capacities and special lengths available on request.

Technical data RSD

| Model | Colour code EN 1492 | Capacity WLL, with one sling, straight pull kg | Capacity WLL, with one sling, choke hitch kg | Capacity WLL, with one sling, basket, angle β up to 7° kg | Capacity WLL, with one sling, basket, angle β 7°- 45° kg | Capacity WLL, with one sling, basket, angle β 45°- 60° kg | Width approx. under load mm | Thickness approx. under load mm | Shortest possible length mm |
|-----------|---------------------|---|---|--|---|--|--------------------------------|------------------------------------|--------------------------------|
| RSD-01000 | violet | 1000 | 800 | 2000 | 1400 | 1000 | 52 | 5 | 500 |
| RSD-02000 | green | 2000 | 1600 | 4000 | 2800 | 2000 | 57 | 6 | 500 |
| RSD-03000 | yellow | 3000 | 2400 | 6000 | 4200 | 3000 | 71 | 9 | 500 |
| RSD-04000 | grey | 4000 | 3200 | 8000 | 5600 | 4000 | 76 | 9 | 500 |

RSX

Round sling with extra thick single sleeve

Made from polyester (PES), EN 1492-2 with extra strong stitchless protection sleeve, with capacity label.

Features

- Optimized woven structure, PU-starched, thermally fixed.
- Easy identification of the annually required UV tests through an additional label showing a check list.
- Colour coding of the protective sleeve.
- Printed-on capacities.
- Woven tonnage stripes, per ton capacity 1 stripe.
- Low weight allows easy handling.
- Protection against hand injuries.
- Protection against cargo surface damage.
- Highly flexible and adaptable to given shapes.
- UV-resistant, eliminating material ageing or embrittlement.
- Heat resistant up to +100 °C.
- Moisture-resistant fabric, thus preventing frost damage (up to approx. -40 °C).



INFO

Special lengths available on request.

Technical data RSX

| Model | Colour code EN 1492 | Capacity WLL, with one sling, straight pull kg | Capacity WLL, with one sling, choke hitch kg | Capacity WLL, with one sling, basket, angle β up to 7° kg | Capacity WLL, with one sling, basket, angle β 7°- 45° kg | Capacity WLL, with one sling, basket, angle β 45°- 60° kg | Width approx. under load mm | Thickness approx. under load mm | Shortest possible length mm |
|-----------|---------------------|---|---|--|---|--|--------------------------------|------------------------------------|--------------------------------|
| RSX-01000 | violet | 1000 | 800 | 2000 | 1400 | 1000 | 52 | 10 | 500 |
| RSX-02000 | green | 2000 | 1600 | 4000 | 2800 | 2000 | 57 | 10 | 500 |
| RSX-03000 | yellow | 3000 | 2400 | 6000 | 4200 | 3000 | 71 | 15 | 500 |
| RSX-04000 | grey | 4000 | 3200 | 8000 | 5600 | 4000 | 76 | 15 | 500 |
| RSX-05000 | red | 5000 | 4000 | 10000 | 7000 | 5000 | 86 | 20 | 1000 |
| RSX-06000 | brown | 6000 | 4800 | 12000 | 8400 | 6000 | 96 | 20 | 1000 |
| RSX-08000 | blue | 8000 | 6400 | 16000 | 11200 | 8000 | 112 | 25 | 1000 |
| RSX-10000 | orange | 10000 | 8000 | 20000 | 14000 | 10000 | 130 | 30 | 1000 |



RSX-XL Heavy duty round sling with extra thick single sleeve

Made from polyester (PES), EN 1492-2 with extra strong stitchless protection sleeve, with capacity label.

Features

- Optimized woven structure, PU-starched, thermally fixed.
- Easy identification of the annually required UVV tests through an additional label showing a check list.
- Colour coding of the protective sleeve.
- Low weight allows easy handling.
- Protection against hand injuries.
- Protection against cargo surface damage.
- Highly flexible and adaptable to given shapes.
- UV-resistant, eliminating material ageing or embrittlement.
- Heat resistant up to +100 °C.
- Moisture-resistant fabric, thus preventing frost damage (up to approx. -40 °C).



Technical data RSX-XL

| Model | Colour code EN 1492 | Capacity WLL, with one sling, straight pull kg | Capacity WLL, with one sling, choke hitch kg | Capacity WLL, with one sling, basket, angle β up to 7° kg | Capacity WLL, with one sling, basket, angle β 7°- 45° kg | Capacity WLL, with one sling, basket, angle β 45°- 60° kg | Width approx. under load mm | Shortest possible length mm |
|---------------|---------------------|---|---|--|---|--|--------------------------------|--------------------------------|
| RSX-XL-12000 | orange | 12000 | 9600 | 24000 | 16800 | 12000 | 150 | 1000 |
| RSX-XL-15000 | orange | 15000 | 12000 | 30000 | 21000 | 15000 | 150 | 1000 |
| RSX-XL-20000 | orange | 20000 | 16000 | 40000 | 28000 | 20000 | 180 | 1000 |
| RSX-XL-25000 | orange | 25000 | 20000 | 50000 | 35000 | 25000 | 180 | 1000 |
| RSX-XL-30000 | orange | 30000 | 24000 | 60000 | 42000 | 30000 | 210 | 1000 |
| RSX-XL-40000 | orange | 40000 | 32000 | 80000 | 56000 | 40000 | 210 | 1000 |
| RSX-XL-50000 | orange | 50000 | 40000 | 100000 | 70000 | 50000 | 240 | 1000 |
| RSX-XL-60000 | orange | 60000 | 48000 | 120000 | 84000 | 60000 | 240 | 1000 |
| RSX-XL-80000 | orange | 80000 | 64000 | 160000 | 112000 | 80000 | 270 | 1500 |
| RSX-XL-100000 | orange | 100000 | 80000 | 200000 | 140000 | 100000 | 270 | 1500 |
| RSX-XL-125000 | orange | 125000 | 100000 | 250000 | 175000 | 125000 | 270 | 2000 |
| RSX-XL-150000 | orange | 150000 | 120000 | 300000 | 210000 | 150000 | 270 | 2000 |



RSE

Round sling with single sleeve

Made from polyester (PES), EN 1492-2 with single stitch-less protection sleeve, with capacity label

Features

- With single sleeve, PU-starched, thermally fixed.
- Colour coding of the protective sleeve.
- Printed-on capacities.
- Woven tonnage stripes, per ton capacity 1 stripe (applies only to round slings up to 10t).
- Low weight allows easy handling.
- Protection against hand injuries.
- Protection against cargo surface damage.
- Highly flexible and adaptable to given shapes.
- UV-resistant, eliminating material ageing or embrittlement.
- Heat resistant up to +100 °C.
- Moisture-resistant fabric, thus preventing frost damage (up to approx. -40 °C).

INFO

Special lengths available on request.

Technical data RSE

| Model | Colour code EN 1492 | Capacity WLL, with one sling, straight pull kg | Capacity WLL, with one sling, choke hitch kg | Capacity WLL, with one sling, basket, angle β up to 7° kg | Capacity WLL, with one sling, basket, angle β 7°- 45° kg | Capacity WLL, with one sling, basket, angle β 45°- 60° kg | Width approx. under load mm | Thickness approx. under load mm | Shortest possible length mm |
|-----------|---------------------|---|---|--|---|--|--------------------------------|------------------------------------|--------------------------------|
| RSE-01000 | violet | 1000 | 800 | 2000 | 1400 | 1000 | 50 | 10 | 500 |
| RSE-02000 | green | 2000 | 1600 | 4000 | 2800 | 2000 | 55 | 10 | 500 |
| RSE-03000 | yellow | 3000 | 2400 | 6000 | 4200 | 3000 | 60 | 15 | 500 |
| RSE-04000 | grey | 4000 | 3200 | 8000 | 5600 | 4000 | 75 | 15 | 500 |
| RSE-05000 | red | 5000 | 4000 | 10000 | 7000 | 5000 | 85 | 20 | 1000 |
| RSE-06000 | brown | 6000 | 4800 | 12000 | 8400 | 6000 | 90 | 20 | 1000 |
| RSE-08000 | blue | 8000 | 6400 | 16000 | 11200 | 8000 | 100 | 25 | 1000 |
| RSE-10000 | orange | 10000 | 8000 | 20000 | 14000 | 10000 | 120 | 30 | 1000 |

20 RSE - Round slings, EN 1492-2

with different working loads and lengths.

With each sports bag you receive:

- 2x RSE 01000, WLL 1000 kg, 0.5m length
- 4x RSE 01000, WLL 1000 kg, 1.0m length
- 2x RSE 01000, WLL 1000 kg, 1.5m length
- 4x RSE 01000, WLL 1000 kg, 2.0m length
- 2x RSE 02000, WLL 2000 kg, 1.0m length
- 2x RSE 02000, WLL 2000 kg, 2.0m length
- 2x RSE 02000, WLL 2000 kg, 3.0m length
- 2x RSE 03000, WLL 3000 kg, 2.0m length

The practical user set for special price!



Art.-No.: N33500011

Minimum purchase: 3 bags



Including sports bag

Round sling assembly Rated capacities for different slinging methods

| | single legged | | double legged | | | | three and four legged | |
|---------|---------------|-------------|--------------------------|-------------|---------------------------|-------------|-----------------------|----------|
| | straight pull | choke hitch | straight pull | choke hitch | straight pull | choke hitch | straight pull | |
| | | | angle β 0°- 45° | | angle β 45°- 60° | | 0°- 45° | 45°- 60° |
| | | | | | | | | |
| Factor | 1.0 | 0.8 | 1.4 | 1.1 | 1.0 | 0.8 | 2.1 | 1.5 |
| 1000 kg | 1000 | 800 | 1400 | 1100 | 1000 | 800 | 2100 | 1500 |
| 2000 kg | 2000 | 1600 | 2800 | 2200 | 2000 | 1600 | 4200 | 3000 |
| 3000 kg | 3000 | 2400 | 4200 | 3300 | 3000 | 2400 | 6300 | 4500 |
| 4000 kg | 4000 | 3200 | 5600 | 4400 | 4000 | 3200 | 8400 | 6000 |
| 5000 kg | 5000 | 4000 | 7000 | 5500 | 5000 | 4000 | 10500 | 7500 |



RSG
Round sling assembly
single legged

EN 1492-2 with high tensile forgings EN 1677.

Technical data RSG single legged

| Model | Capacity WLL straight pull kg |
|------------------|-------------------------------------|
| RSG-01000-1-SIKA | 1000 |
| RSG-02000-1-SIKA | 2000 |
| RSG-03000-1-SIKA | 3000 |
| RSG-04000-1-SIKA | 4000 |
| RSG-05000-1-SIKA | 5000 |



RSG
Round sling assembly
double legged

EN 1492-2 with high tensile forgings EN 1677.

Technical data RSG double legged

| Model | Capacity WLL, straight pull angle β 0°- 45° kg | Capacity WLL, straight pull angle β 45°- 60° kg |
|------------------|--|---|
| RSG-01000-2-SIKA | 1400 | 1000 |
| RSG-02000-2-SIKA | 2800 | 2000 |
| RSG-03000-2-SIKA | 4200 | 3000 |
| RSG-04000-2-SIKA | 5600 | 4000 |
| RSG-05000-2-SIKA | 7000 | 5000 |

INFO

Standard length 1-3 m. Attention: The mentioned lengths refer to the useable length L1 of the round sling.

RSG
Round sling assembly
three legged

EN 1492-2 with high tensile forgings EN 1677.

Technical data RSG three legged

| Model | Capacity WLL, straight pull angle β 0°- 45° kg | Capacity WLL, straight pull angle β 45°- 60° kg |
|------------------|--|---|
| RSG-01000-3-SIKA | 2100 | 1500 |
| RSG-02000-3-SIKA | 4200 | 3000 |
| RSG-03000-3-SIKA | 6300 | 4500 |
| RSG-04000-3-SIKA | 8400 | 6000 |
| RSG-05000-3-SIKA | 10500 | 7500 |



RSG
Round sling assembly
four legged

EN 1492-2 with high tensile forgings EN 1677.

Technical data RSG four legged

| Model | Capacity WLL, straight pull angle β 0°- 45° kg | Capacity WLL, straight pull angle β 45°- 60° kg |
|------------------|--|---|
| RSG-01000-4-SIKA | 2100 | 1500 |
| RSG-02000-4-SIKA | 4200 | 3000 |
| RSG-03000-4-SIKA | 6300 | 4500 |
| RSG-04000-4-SIKA | 8400 | 6000 |
| RSG-05000-4-SIKA | 10500 | 7500 |



INFO

Other lengths and capacities upon request.



HSE

Endless flat webbing sling, single ply

Made from polyester (PES), EN 1492-1 form A2, with capacity label.

Features

- Single ply, PU-starched, thermally fixed.
- Colour coded webbing.
- Woven tonnage stripes.
- Low weight allows easy handling.
- Protection against hand injuries.
- Protection against cargo surface damage.
- Consistent pressure distribution onto pressure- and pull sensitive loads.
- UV-resistant, eliminating material ageing or embrittlement.
- Heat resistant up to +100 °C.
- Moisture-resistant fabric, thus preventing frost damage (up to approx. -40 °C).
- Low elongation (< 4%).

Technical data HSE

| Model | Colour code EN 1492 | Capacity WLL, with one sling, straight pull kg | Capacity WLL, with one sling, choke hitch kg | Capacity WLL, with one sling, basket, angle β up to 7° kg | Capacity WLL, with one sling, basket, angle β 7°- 45° kg | Capacity WLL, with one sling, basket, angle β 45°- 60° kg | Webbing width mm | Shortest possible length mm |
|-----------|---------------------|---|---|--|---|--|---------------------|--------------------------------|
| HSE-01000 | violet | 1000 | 800 | 2000 | 1400 | 1000 | 30 | 500 |
| HSE-02000 | green | 2000 | 1600 | 4000 | 2800 | 2000 | 60 | 500 |
| HSE-03000 | yellow | 3000 | 2400 | 6000 | 4200 | 3000 | 90 | 500 |

INFO

Further capacities (up to 20t) and special lengths available on request.

HSE-E Disposable endless flat woven webbing slings, single ply

Made from polyester (PES), DIN 60005, with capacity label.



Features

- Single ply, PU-starched, thermally fixed.
- Low weight allows easy handling.
- Protection against hand injuries.
- Protection against cargo surface damage.
- Consistent pressure distribution onto pressure- and pull sensitive loads.
- UV-resistant, eliminating material ageing or embrittlement.
- Heat resistant up to +100 °C.
- Moisture-resistant fabric, thus preventing frost damage (up to approx. -40 °C).
- Low elongation (< 4%).

INFO

Min. order quantity: 100 pcs. per product code.

Technical data HSE-E

| Model | Capacity WLL, with one sling, straight pull kg | Capacity WLL, with one sling, choke hitch kg | Capacity WLL, with one sling, basket, angle β up to 7° kg | Capacity WLL, with one sling, basket, angle β 7°- 45° kg | Capacity WLL, with one sling, basket, angle β 45°- 60° kg | Webbing width mm | Shortest possible length mm |
|-------------|---|---|--|---|--|---------------------|--------------------------------|
| HSE-E-00500 | 500 | 400 | 1000 | 700 | 500 | 25 | 200 |
| HSE-E-00750 | 750 | 600 | 1500 | 1050 | 750 | 48 | 200 |
| HSE-E-01000 | 1000 | 800 | 2000 | 1400 | 1000 | 35 | 200 |
| HSE-E-01500 | 1500 | 1200 | 3000 | 2100 | 1500 | 50 | 250 |



HBD

Flat webbing sling, duplex construction, reinforced eyes

Made from polyester (PES), EN 1492-1 form B2, with capacity label.

Features

- Duplex construction, PU-starched, thermally fixed.
- With reinforced eyes.
- Woven tonnage stripes. (up to WLL 10 t).
- Low weight allows easy handling.
- Protection against hand injuries.
- Protection against cargo surface damage.
- Consistent pressure distribution onto pressure- and pull sensitive loads.
- UV-resistant, eliminating material ageing or embrittlement.
- Heat resistant up to +100 °C.
- Moisture-resistant fabric, thus preventing frost damage (up to approx. -40 °C).
- Low elongation (< 4 %).

INFO

Special lengths available on request.

Technical data HBD

| Model | Colour code EN 1492 | Capacity WLL, with one sling, straight pull kg | Capacity WLL, with one sling, choke hitch kg | Capacity WLL, with one sling, basket, angle β up to 7° kg | Capacity WLL, with one sling, basket, angle β 7°- 45° kg | Capacity WLL, with one sling, basket, angle β 45°- 60° kg | Webbing width mm | Eye length approx. mm | Eye width approx. mm | Shortest possible length mm |
|-----------|---------------------|---|---|--|---|--|---------------------|--------------------------|-------------------------|--------------------------------|
| HBD-01000 | violet | 1000 | 800 | 2000 | 1400 | 1000 | 30 | 300 | 30 | 750 |
| HBD-02000 | green | 2000 | 1600 | 4000 | 2800 | 2000 | 60 | 350 | 30 | 1000 |
| HBD-03000 | yellow | 3000 | 2400 | 6000 | 4200 | 3000 | 90 | 400 | 45 | 1000 |
| HBD-04000 | grey | 4000 | 3200 | 8000 | 5600 | 4000 | 120 | 500 | 60 | 1500 |
| HBD-05000 | red | 5000 | 4000 | 10000 | 7000 | 5000 | 150 | 550 | 75 | 1500 |
| HBD-06000 | brown | 6000 | 4800 | 12000 | 8400 | 6000 | 180 | 600 | 90 | 2000 |
| HBD-08000 | blue | 8000 | 6400 | 16000 | 11200 | 8000 | 240 | 650 | 120 | 2500 |
| HBD-10000 | orange | 10000 | 8000 | 20000 | 14000 | 10000 | 300 | 900 | 150 | 2500 |
| HBD-12000 | orange | 12000 | 9600 | 24000 | 16800 | 12000 | 300 | 900 | 150 | 3000 |

HBQ
Flat webbing sling,
four ply,
reinforced eyes

Made from polyester (PES), EN 1492-1 form B4, with capacity label.

Features

- Four-layered stitched, PU-starched, thermally fixed.
- With reinforced eyes.
- Low weight allows easy handling.
- Protection against hand injuries.
- Protection against cargo surface damage.
- Consistent pressure distribution onto pressure- and pull sensitive loads.
- UV-resistant, eliminating material ageing or embrittlement.
- Heat resistant up to +100 °C.
- Moisture-resistant fabric, thus preventing frost damage (up to approx. -40 °C).
- Low elongation (< 4%).



INFO

Other capacities upon request.

Technical data HBQ

| Model | Capacity WLL, with one sling, straight pull kg | Capacity WLL, with one sling, choke hitch kg | Capacity WLL, with one sling, basket, angle β up to 7° kg | Capacity WLL, with one sling, basket, angle β 7°- 45° kg | Capacity WLL, with one sling, basket, angle β 45°- 60° kg | Webbing width mm | Eye length approx. mm | Eye width approx. mm | Shortest possible length mm |
|-----------|---|---|--|---|--|---------------------|--------------------------|-------------------------|--------------------------------|
| HBQ-04000 | 4000 | 3200 | 8000 | 5600 | 4000 | 60 | 350 | 30 | 1000 |
| HBQ-06000 | 6000 | 4800 | 12000 | 8400 | 6000 | 90 | 400 | 45 | 1000 |
| HBQ-08000 | 8000 | 6400 | 16000 | 11200 | 8000 | 120 | 500 | 60 | 1500 |
| HBQ-10000 | 10000 | 8000 | 20000 | 14000 | 10000 | 150 | 550 | 75 | 1500 |
| HBQ-12000 | 12000 | 9600 | 24000 | 16800 | 12000 | 180 | 600 | 90 | 2000 |
| HBQ-16000 | 16000 | 12800 | 32000 | 22400 | 16000 | 240 | 650 | 120 | 2500 |
| HBQ-20000 | 20000 | 16000 | 40000 | 28000 | 20000 | 300 | 900 | 150 | 2500 |
| HBQ-25000 | 25000 | 20000 | 50000 | 35000 | 25000 | 300 | 900 | 150 | 3000 |
| HBQ-30000 | 30000 | 24000 | 60000 | 42000 | 30000 | 400 | 1100 | 200 | 4000 |



HBD-ED Webbing sling, duplex construction, steel links on both ends

Made from polyester (PES), EN 1492-1 form C2 and Cr2, with capacity label.

Features

- Duplex construction, PU-starched, thermally fixed.
- With reeable steel links.
- Woven tonnage stripes.
- Protection against hand injuries.
- Protection against cargo surface damage.
- Consistent pressure distribution onto pressure- and pull sensitive loads.
- UV-resistant, eliminating material ageing or embrittlement.
- Heat resistant up to +100 °C.
- Moisture-resistant fabric, thus preventing frost damage (up to approx. -40 °C).
- Low elongation (< 4%).

INFO

HBD-ED - links are reeable, webbing sling also applicable for use in choke hitch.

Technical data HBD-ED

| Model | Colour code EN 1492 | Capacity WLL, with one sling, straight pull kg | Capacity WLL, with one sling, choke hitch kg | Capacity WLL, with one sling, basket, angle β up to 7° kg | Capacity WLL, with one sling, basket, angle β 7°- 45° kg | Capacity WLL, with one sling, basket, angle β 45°- 60° kg | For webbing width mm | Link dimension HBD-ED b x d x t mm |
|--------------|---------------------|---|---|--|---|--|-------------------------|--|
| HBD-01000-ED | violet | 1000 | 800 | 2000 | 1400 | 1000 | 30 | 40 x 13 x 80 |
| HBD-02000-ED | green | 2000 | 1600 | 4000 | 2800 | 2000 | 60 | 75 x 16 x 125 |
| HBD-03000-ED | yellow | 3000 | 2400 | 6000 | 4200 | 3000 | 90 | 105 x 20 x 165 |
| HBD-04000-ED | grey | 4000 | 3200 | 8000 | 5600 | 4000 | 120 | 135 x 23 x 210 |

INFO

Other capacities upon request.

PU-SC

PU-protection sleeve, single and double-sided

Made from cut resistant polyurethane

With inner fabric insert to ease sliding of the sleeve on the webbing. Standard length 2 and 4 m.

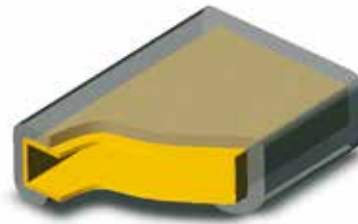

PU-protection sleeve single-sided,
PU-SC-1

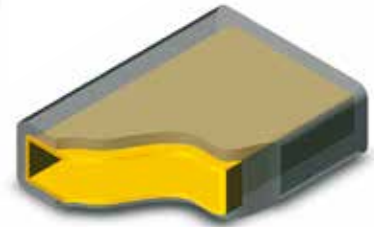

PU-protection sleeve,
PU-SC-2

INFO

Lengths over 4 m on request.

Technical data PU-SC, single-sided

| Model | Art.-No. | For webbing width | Dimensions outside/inside | Height |
|------------|-----------|-------------------|------------------------------|--------|
| | | mm | mm | mm |
| PU-SC1-030 | N39120011 | 30 | 50 / 40 | 22 |
| PU-SC1-050 | N39120001 | 50 | 70 / 60 | 22 |
| PU-SC1-060 | N39120002 | 60 | 80 / 70 | 22 |
| PU-SC1-090 | N39120004 | 90 | 110 / 100 | 22 |
| PU-SC1-120 | N39120012 | 120 | 145 / 135 | 22 |
| PU-SC1-150 | N39120007 | 150 | 170 / 160 | 22 |
| PU-SC1-180 | N39120008 | 180 | 200 / 190 | 22 |
| PU-SC1-240 | N39120009 | 240 | 260 / 250 | 31 |
| PU-SC1-300 | N39120010 | 300 | 330 / 320 | 31 |

Technical data PU-SC, double-sided

| Model | Art.-No. | For webbing width | Dimensions outside/inside | Height |
|------------|-----------|-------------------|------------------------------|--------|
| | | mm | mm | mm |
| PU-SC2-030 | N39130014 | 30 | 50 / 40 | 22 |
| PU-SC2-050 | N39130001 | 50 | 70 / 60 | 22 |
| PU-SC2-060 | N39130002 | 60 | 80 / 70 | 22 |
| PU-SC2-090 | N39130004 | 90 | 110 / 100 | 22 |
| PU-SC2-120 | N39130007 | 120 | 145 / 135 | 22 |
| PU-SC2-150 | N39130009 | 150 | 170 / 160 | 22 |
| PU-SC2-180 | N39130011 | 180 | 200 / 190 | 22 |
| PU-SC2-240 | N39130012 | 240 | 260 / 250 | 31 |
| PU-SC2-300 | N39130013 | 300 | 330 / 320 | 31 |

INFO

Double PU sleeves cannot be fitted subsequently on webbing slings with steel links. If required, state sleeve length when placing the webbing sling order.



PU-KSW PU-edge protector

Made from cut resistant polyurethane
With slots to allow easy attachment and fixing on the round sling.

Technical data PU-KSW

| Model | Art.-No. | Diameter mm | Length mm | Suitable for round slings up to WLL kg |
|-----------|-----------|----------------|--------------|--|
| PU-KSW-30 | N39160006 | 30 | 80 | 3000 |
| PU-KSW-50 | N39160007 | 50 | 125 | 5000 |



PU-SG Round sleeve

With fabric insert and PU-coating
Economical solution to protect webbing slings and round slings against wear caused by abrasion.

INFO

Not suitable for protection against sharp edges.

Technical data PU-SG

| Model | Art.-No. | Width approx. mm | Diameter mm | Suitable for round slings up to WLL kg |
|-----------|-----------|---------------------|----------------|--|
| PU-SG-040 | N39140001 | 60 | 40 | 2000 |
| PU-SG-063 | N39140002 | 95 | 63 | 3000 |
| PU-SG-075 | N39140003 | 115 | 75 | 6000 |
| PU-SG-090 | N39140004 | 140 | 90 | 8000 |
| PU-SG-110 | N39140005 | 170 | 110 | 10000 |
| PU-SG-150 | N39140006 | 230 | 150 | 15000 |

PU-FB
PU-coating,
single and double-sided

Made from transparent polyurethane

Extremely wear and cut resistant. The coating is permanently fixed to the webbing and cannot be lost during usage.

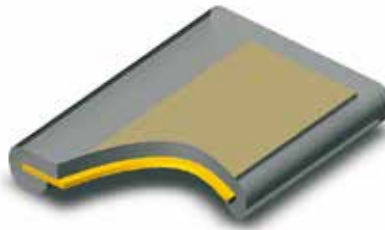

Coating single-sided,
 PU-FB 1

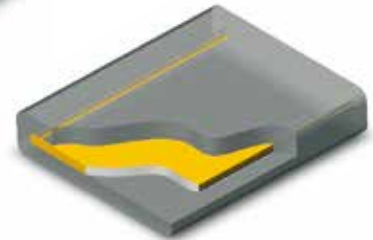

Coating double-sided,
 PU-FB 2

Technical data PU-FB, single-sided

| Model | Art.-No. | For webbing width mm | Width mm |
|------------|-----------|-------------------------|-------------|
| PU-FB1-030 | N39100009 | 30 | 40 |
| PU-FB1-050 | N39100001 | 50 | 60 |
| PU-FB1-060 | N39100002 | 60 | 70 |
| PU-FB1-090 | N39100003 | 90 | 100 |
| PU-FB1-120 | N39100004 | 120 | 130 |
| PU-FB1-150 | N39100005 | 150 | 160 |
| PU-FB1-180 | N39100006 | 180 | 190 |
| PU-FB1-240 | N39100007 | 240 | 250 |
| PU-FB1-300 | N39100008 | 300 | 310 |

Technical data PU-FB, double-sided

| Model | Art.-No. | For webbing width mm | Width mm |
|------------|-----------|-------------------------|-------------|
| PU-FB2-030 | N39110009 | 30 | 40 |
| PU-FB2-050 | N39110001 | 50 | 60 |
| PU-FB2-060 | N39110002 | 60 | 70 |
| PU-FB2-090 | N39110003 | 90 | 100 |
| PU-FB2-120 | N39110004 | 120 | 130 |
| PU-FB2-150 | N39110005 | 150 | 160 |
| PU-FB2-180 | N39110006 | 180 | 190 |
| PU-FB2-240 | N39110007 | 240 | 250 |
| PU-FB2-300 | N39110008 | 300 | 310 |

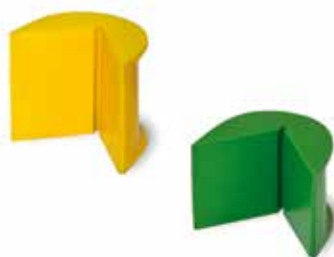

PU-KSE

Edge protection profile

From colour coded polyurethane, extremely abrasive and cut resistant.

Technical data PU-KSE

| Model | Art.-No. | Colour mm | For webbing width mm | Width mm |
|------------|-----------|-----------|----------------------|----------|
| PU-KSE-065 | N39160023 | green | 60 | 100 |
| PU-KSE-100 | N39160024 | yellow | 90 | 135 |
| PU-KSE-125 | N39160025 | grey | 120 | 160 |
| PU-KSE-150 | N39160026 | red | 150 | 185 |
| PU-KSE-200 | N39160027 | black | 180 | 225 |
| PU-KSE-300 | N39160028 | orange | 300 | 330 |



PU-KSE-MAG

Edge protection profile with magnets

From colour coded polyurethane, extremely abrasive and cut resistant.

Technical data PU-KSE-MAG

| Model | Art.-No. | Colour mm | For webbing width mm | Width mm | Number of magnets |
|----------------|-----------|-----------|----------------------|----------|-------------------|
| PU-KSE-065-MAG | N39160029 | green | 60 | 100 | 2 |
| PU-KSE-100-MAG | N39160030 | yellow | 90 | 135 | 4 |
| PU-KSE-125-MAG | N39160031 | grey | 120 | 160 | 4 |
| PU-KSE-150-MAG | N39160032 | red | 150 | 185 | 4 |
| PU-KSE-200-MAG | N39160033 | black | 180 | 225 | 6 |
| PU-KSE-300-MAG | N39160034 | orange | 300 | 330 | 8 |

Trucker Set

With each sport bag you receive:

- 2x Ratchet lashing, LC 250 daN, 25 mm, one-part, L=4.0 m
- 2x Ratchet lashing, LC 1000 daN, 35 mm, one-part, L=6.0 m
- 2x Ratchet lashing, LC 250 daN, 25 mm, two-part, double J hook, L=4.0 m
- 2x Ratchet lashing, LC 1000 daN, 35 mm, two-part, double J hook, L=6.0 m
- 4x Ratchet lashing, LC 2000 daN, 50 mm, two-part, double J hook, L=8.0 m
- 4x Edge protector, for 50 mm webbing width

- 4x Slip restraining mats, 250 x 100 x 8 mm

Part-No.: N35500002

Minimum purchase: 2 bags

The practical user set for special price!



Including sports bag



OFNE

General information about load security

The varying forces, which can result in slipping, rolling, tilting or even lift-off of loads during transport, are regularly underestimated. Possible consequences are e.g. that the vehicle gets out of control, the driving cab is damaged, the vehicle even overturns and the falling load endangers others! The common assumption that very heavy loads do not require lashing security, is a fatal error. Lashing of loads may be performed by competent users (trained in theory and practice) only.

Some basic rules about load security with ratchet lashings

- Depending on the cargo, consideration shall be given to select an appropriate vehicle with adequate structures and lashing points.
- The load centre of gravity should be as low as possible and ideally positioned according to the load distribution plan of the vehicle.
- The permissible gross weight and loads per axle must not be exceeded.
- The load should be stored as close and low as possible and should not leave free space between load, front wall or side walls. Free spaces between the outer walls and the load should be stuffed where possible.
- Depending on the type of cargo, the driving speed should be conform to the road and traffic situation as well as to the driving quality of the vehicle.
- Adverse friction values between cargo and loading area (oily metals, wet areas etc.) will considerably increase the requirement for a correct security of the load. Slip restraining mats will contribute to achieve a more economic and efficient load lashing security.
- Unstable cargo is very susceptible to tilting and in most cases has to be lashed extensively (calculation against slipping and tilting).
- Positive load lashing (e.g. supporting the cargo at front and side walls or with wedges or scantlings fixed on the loading platform) will contribute substantially to the stabilisation of the cargo and to reduction of additional lashing requirement.

Forces on cargo loads (EN 12195)

Truck and trailer loading (road transport) – Acceleration coefficients

During road transport the heaviest stresses on the load security equipment will occur during braking, lift-off of the load by vibration and impact as well as centrifugal forces in narrow curves.

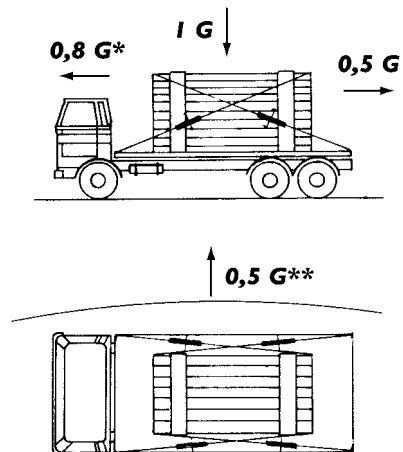

* The value for the longitudinal acceleration in combined traffic (lorry and/or trailer during rail transport) has to be calculated with 1G.

** 0.7 for tilting of instable cargo loads

Lashing methods

Over top lashing

Over top lashing consists of tensioning the lashings to the tension force so as to increase the friction force at the contact surface of the load to avoid any sliding of the load. Influence factors are the dimensions of the load, the acceleration values, the dynamic friction factors as well as the lashing angle.

The calculation of lashing forces will give the required tension force of the lashing devices.

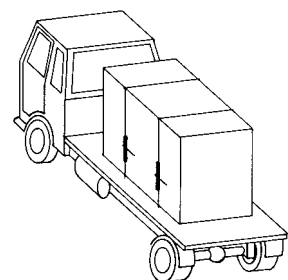

This user information presents a general overview regarding the application of web lashings and does not substitute the existing operating instructions for specific products!

Lashing operations with textile lashing equipment may be carried out by competent users (trained in theory and practice) only. When operated correctly, our textile lashings offer the highest degree of safety in line with long life expectancy and avoid damage to material and people.

Limitations of use

Temperature

Textile lashings in accordance with this part of the European standard EN 12195 are suitable for the following temperature areas:

- a) -40 °C up to +80 °C for polypropylene (PP)
- b) -40 °C up to +100 °C for polyamide (PA)
- c) -40 °C up to +120 °C for polyester (PES)

These temperature areas may change in chemical environments. In this case consult the manufacturer or supplier for advice.

A change of the ambient temperature during transport may influence the tension force of the textile lashing. The tension force should be checked after entering warm regions.

Chemicals

The resistance against chemical influences varies depending on the materials used for the textile lashing. Please observe the advice of the manufacturer, if the textile lashings are subjected to chemicals. Also consider that the effect of the chemical influence will increase with rising temperatures. The resistance of synthetic fibre against chemical influences is summarised as follows:

- a) Polyamides are resistant against alkaline but affected by mineral acids.
- b) Polyester is resistant against mineral acids but affected by alkaline solutions.
- c) Polypropylene is hardly affected by acids and alkaline and is suited for applications that require high resistance against chemicals (except some organic solvents).
- d) Harmless acid or alkaline solutions may be concentrated by evaporation and lead to damages. Affected textile lashings have to be taken out of service immediately, thoroughly rinsed in cold water and dried in the open-air.

Operation in danger zones

During loading and unloading observe low hanging aerial contact lines.

Application advices

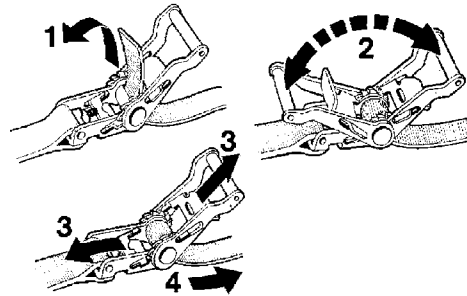

- Selection and use of textile lashings depend on the required tensioning force as well as the mode of application and type of cargo to be lashed. Size, form and weight of the cargo determine the correct choice in addition to the intended usage. For stability reasons, at least two lashing systems should be used for over top lashing and two pairs of lashing straps for diagonal lashing.
- The selected web lashing must be strong enough for the intended job and have the correct length for the type of lashing. Always consider adequate lashing practice: Attachment and removal of lashings should be planned before the start of the journey. In case of longer trips, partial unloadings must be considered. The number of lashings must be calculated as per EN 12195-1:2000. Over top lashing requires systems, which are labelled STF for over top lashing.
- On account of different characteristics and change of length under load, different lashings (e.g. lashing chains and web lashings) may not be used for lashing the same load. When using additional fittings or lashing devices, make sure that these correspond to the existing web lashing.
- During operation, flat hooks must be in contact with the full width of the hook mouth.

O
L
E
N

INFO

- Releasing of the lashing: Prior to releasing, make sure that the load stands safely (even without safety device) and does not endanger the operator by falling. Before departure check whether additional lashings will be required for further transportation after partial unloading has occurred.
This is also true for lashing elements which permit safe removal.
- Prior to unloading, the lashings must be released to an extent that the load stands freely.
- Make sure that the web lashing will not be damaged by the edges of the cargo. A visual inspection should be standard procedure before and after each usage.
- Only use textile lashings with legible identity labels.
- Textile lashings must not be overloaded:
The max. hand force of 500 N (50 daN on the label; 1 daN = approx. 1 kg) may be applied with one hand only. Do not use cheater bars or levers unless they are part of the lashing element.
- Knotted textile lashings must not be used.
- Damages to the identity labels should be avoided by keeping them away from the edges of the cargo.
- Textile lashings should be protected against friction and abrasion and damages by sharp edges by application of protective sleeves and/or edge protectors.

Labelling

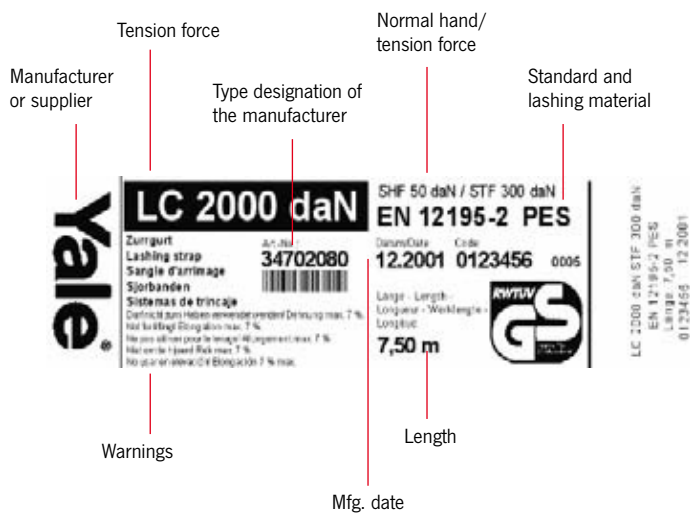

Maintenance and repair

Textile lashings may only be repaired if provided with legible identity labels. In case of accidental contact with chemicals, the web lashing has to be withdrawn from service and the manufacturer or supplier consulted for advice.

Criteria for disposal of textile lashings

Textile lashings must be withdrawn from service and returned for repair to the manufacturer in case of obvious defects. The following points are signs of possible damages:

Textile lashings:

- Cracks, cuts, notches and breaks in the load bearing strands and seams as well as deformations by heat;

Tensioning devices and fittings:

- Deformations, cracks, obvious signs of wear and corrosion.

The quantity of textile lashings has to be calculated according to EN 12195-1:2010

Only use lashing systems for over top lashing which show STF on the label. For easy identification of the required quantity of textile lashings or existing lashings needed for the cargo to be lashed refer to the following table, which has been calculated with friction coefficients of $\mu = 0.2$, $\mu = 0.4$ and $\mu = 0.6$ at various angles of elevation α .

- The calculation refers to situations with min. two, however max. ten textile lashings.
- Whenever possible, always use a slip resistant mat with a certified friction coefficient of 0.6!
- Always operate with the highest possible angle of elevation and lash as steep as possible!!!
- The friction coefficients are applicable for clean and dry surfaces, well covered from frost, ice and snow. In case of moisture refer to the direct lashing method or double the amount of textile lashings!

Friction factors according to EN 12195-1:2010

| Combination of materials in the contact surface | Friction factor μ | when using a slip resistant mat |
|---|-----------------------|---------------------------------|
| Cut timber against fabric base laminate/plywood | 0.5 | 0.6 |
| Cut timber against grooved aluminium | 0.4 | 0.6 |
| Cut timber against steel sheets | 0.4 | 0.6 |
| Cut timber against shrink films | 0.3 | 0.6 |
| Shrink films against fabric base laminate/plywood | 0.4 | 0.6 |
| Shrink films against grooved aluminium | 0.4 | 0.6 |
| Shrink films against steel sheets | 0.4 | 0.6 |
| Shrink films against shrink films | 0.4 | 0.6 |
| Cardboard box against cardboard box | 0.5 | 0.6 |
| Cardboard box against wooden pallet | 0.5 | 0.6 |
| Big bags against wooden pallet | 0.4 | 0.6 |
| Flat steel bars against cut timber | 0.5 | 0.6 |
| Unpainted corrugated sheets against cut timber | 0.5 | 0.6 |
| Painted corrugated sheets against cut timber | 0.4 | 0.6 |
| Unpainted corrugated sheets against unpainted corrugated sheets | 0.3 | 0.6 |
| Painted corrugated sheets against painted corrugated sheets | 0.2 | 0.6 |

Number of required textile lashings for different cargo weights

- at different friction factors
- at different angles

Tension force of ratchet 300 daN at standard hand force of 50 daN according to EN 12195

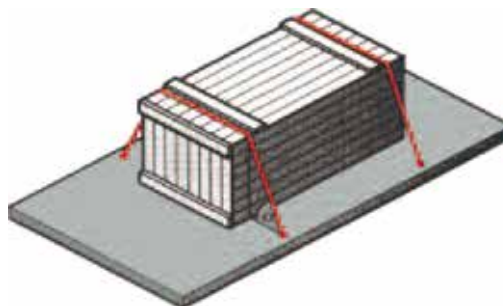

Applicable to textile lashings ZGR-50-2500 with LC 2500 daN and ZGR-50-2000 with LC 2000 daN

| Cargo weight | Friction factor μ 0.20 Top angle | | | Friction factor μ 0.40 Top angle | | | Friction factor μ 0.60 Top angle | | |
|--------------|---|-----|-----|---|-----|-----|---|-----|-----|
| | 30° | 60° | 90° | 30° | 60° | 90° | 30° | 60° | 90° |
| 1000 kg | | 10 | 9 | 7 | 4 | 3 | 3 | 2 | 2 |
| 2000 kg | | | | | 8 | 7 | 6 | 3 | 3 |
| 3000 kg | | | | | | 10 | 9 | 5 | 4 |
| 4000 kg | | | | | | | | 7 | 6 |
| 5000 kg | | | | | | | | 8 | 7 |
| 6000 kg | | | | | | | | 10 | 9 |
| 7000 kg | | | | | | | | | 10 |
| 8000 kg | | | | | | | | | |
| 9000 kg | | | | | | | | | |
| 10000 kg | | | | | | | | | |

Cells without indication require more than 10 web lashings. In these cases a reasonable cargo securing can only be obtained by direct lashing method. Obstruction forces by cargo boards and form-fit locking devices have not been considered.



ZGK-25-250 Cambuckle lashing

Made from polyester (PES), EN 12195-2
25 mm - lashing capacity LC 250 daN.

Features

- Standard tension force STF 30 daN at standard hand force SHF 50 daN.
- Standard lengths 2 m, 4 m and 6 m.

INFO

Other lengths on request.

Technical data ZGK-25-250

| Model | Art.-No. | Version | Lashing capacity LC daN | Webbing width mm | Length of lashing mm |
|--------------|-----------|----------|-------------------------|------------------|----------------------|
| ZGK-25-250-1 | 192067490 | one-part | 250 | 25 | 2000 |
| ZGK-25-250-1 | N35100240 | one-part | 250 | 25 | 4000 |
| ZGK-25-250-1 | N35100260 | one-part | 250 | 25 | 6000 |



ZGR-25-400 Ratchet lashing

Made from polyester (PES), EN 12195-2
25 mm - lashing capacity LC 400 daN.

Features

- Standard tension force STF 50 daN at standard hand force SHF 50 daN.
- Standard lengths 4 m and 6 m.



INFO

Other lengths on request.

Technical data ZGR-25-400

| Model | Art.-No. | Version | Lashing capacity LC daN | Webbing width mm | Length of lashing mm |
|------------------|-----------|-------------------------------|-------------------------|------------------|----------------------|
| ZGR-25-400-1 | N34100440 | one-part | 400 | 25 | 4000 |
| ZGR-25-400-1 | N34100460 | one-part | 400 | 25 | 6000 |
| ZGR-25-400-2-SPH | N34700440 | two-part - with double J hook | 400 | 25 | 4000 |
| ZGR-25-400-2-SPH | N34700460 | two-part - with double J hook | 400 | 25 | 6000 |

ZGR-25-500 Ratchet lashing

Made from polyester (PES), EN 12195-2
25 mm - lashing capacity LC 500 daN.

Features

- Standard tension force STF 100 daN at standard hand force SHF 50 daN.
- Standard lengths 2 m, 4 m and 6 m.



INFO

Other lengths on request.

Technical data ZGR-25-500

| Model | Art.-No. | Version | Lashing capacity LC daN | Webbing width mm | Length of lashing mm |
|------------------|-----------|-------------------------------|-------------------------|------------------|----------------------|
| ZGR-25-500-1 | 192067491 | one-part | 500 | 25 | 2000 |
| ZGR-25-500-1 | N34100540 | one-part | 500 | 25 | 4000 |
| ZGR-25-500-1 | N34100560 | one-part | 500 | 25 | 6000 |
| ZGR-25-500-2-SPH | 192067503 | two-part - with double J hook | 500 | 25 | 2000 |
| ZGR-25-500-2-SPH | N34700540 | two-part - with double J hook | 500 | 25 | 4000 |
| ZGR-25-500-2-SPH | N34700560 | two-part - with double J hook | 500 | 25 | 6000 |



ZGR-35-1000 Ratchet lashing

Made from polyester (PES), EN 12195-2
35 mm - lashing capacity LC 1000 daN.

Features

- Standard tension force STF 150 daN at standard hand force SHF 50 daN.
- Standard lengths 4 m, 6 m and 8 m.

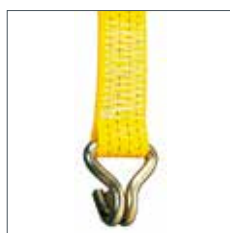

SPH - with double J hook



Technical data ZGR-35-1000

| Model | Art.-No. | Version | Lashing capacity LC daN | Webbing width mm | Length of lashing mm |
|-------------------|-----------|-------------------------------|-------------------------|------------------|----------------------|
| ZGR-35-1000-1 | 192067506 | one-part | 1000 | 35 | 4000 |
| ZGR-35-1000-1 | N34101060 | one-part | 1000 | 35 | 6000 |
| ZGR-35-1000-1 | N34101080 | one-part | 1000 | 35 | 8000 |
| ZGR-35-1000-2-SPH | 192067515 | two-part - with double J hook | 1000 | 35 | 4000 |
| ZGR-35-1000-2-SPH | N34701060 | two-part - with double J hook | 1000 | 35 | 6000 |
| ZGR-35-1000-2-SPH | N34701080 | two-part - with double J hook | 1000 | 35 | 8000 |

INFO

Other end fittings (hooks) and individual prints on webbing are available on request.

Other lengths on request.

ZGR-50-2000 Ratchet lashing

Made from polyester (PES), EN 12195-2
50 mm - lashing capacity LC 2000 daN.

Features

- Standard tension force STF 300 daN at standard hand force SHF 50 daN.
- Standard lengths 6 m, 8 m and 10 m.



GKH - with twisted snap hook



SPH - with double J hook

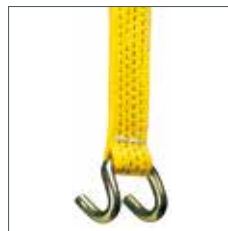

KLH - with claw hook

Technical data ZGR-50-2000

| Model | Art.-No. | Version | Lashing capacity LC | Webbing width | Length of lashing |
|--------------------|---------------|--|---------------------|---------------|-------------------|
| | | | daN | mm | mm |
| ZGR-50-2000-1 | N34199999-166 | one-part | 2000 | 50 | 6000 |
| ZGR-50-2000-1 | N34102080 | one-part | 2000 | 50 | 8000 |
| ZGR-50-2000-1 | N34102010 | one-part | 2000 | 50 | 10000 |
| ZGR-50-2000-2-GKH | N34202080 | two-part - with snap hook | 2000 | 50 | 8000 |
| ZGR-50-2000-2-GKH | N34202010 | two-part - with snap hook | 2000 | 50 | 10000 |
| ZGR-50-2000-2-KLH | N34302080 | two-part - with claw hook | 2000 | 50 | 8000 |
| ZGR-50-2000-2-KLH | N34302010 | two-part - with claw hook | 2000 | 50 | 10000 |
| ZGR-50-2000-FE-KLH | N34302005 | Fixed end with ratchet and claw hook | 2000 | 50 | 400 |
| ZGR-50-2000-2-SPH | N34799999-248 | two-part - with double J hook | 2000 | 50 | 6000 |
| ZGR-50-2000-2-SPH | N34702080 | two-part - with double J hook | 2000 | 50 | 8000 |
| ZGR-50-2000-2-SPH | N34702010 | two-part - with double J hook | 2000 | 50 | 10000 |
| ZGR-50-2000-FE-SPH | N34702005 | Fixed end with ratchet and double J hook | 2000 | 50 | 400 |

INFO

Other end fittings (hooks) and individual prints on webbing are available on request.

Other lengths on request.



ZGR-50-2500 Ratchet lashing

Made from polyester (PES), EN 12195-2
50 mm - lashing capacity LC 2500 daN.

Features

- Standard tension force STF 300 daN at standard hand force SHF 50 daN.
- Standard lengths 8m and 10m



GKH - with twisted snap hook



SPH - with double J hook

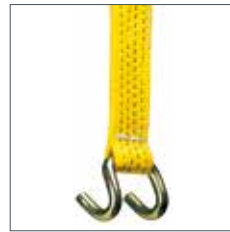

KLH - with claw hook

Technical data ZGR-50-2500

| Model | Art.-No. | Version | Lashing capacity LC daN | Webbing width mm | Length of lashing mm |
|--------------------|-----------|--|-------------------------|------------------|----------------------|
| ZGR-50-2500-1 | N34102580 | one-part | 2500 | 50 | 8000 |
| ZGR-50-2500-1 | N34102510 | one-part | 2500 | 50 | 10000 |
| ZGR-50-2500-2-GKH | N34202580 | two-part - with snap hook | 2500 | 50 | 8000 |
| ZGR-50-2500-2-GKH | N34202510 | two-part - with snap hook | 2500 | 50 | 10000 |
| ZGR-50-2500-2-KLH | N34302580 | two-part - with claw hook | 2500 | 50 | 8000 |
| ZGR-50-2500-2-KLH | N34302510 | two-part - with claw hook | 2500 | 50 | 10000 |
| ZGR-50-2500-FE-KLH | N34302505 | Fixed end with ratchet and claw hook | 2500 | 50 | 400 |
| ZGR-50-2500-2-SPH | N34702580 | two-part - with double J hook | 2500 | 50 | 8000 |
| ZGR-50-2500-2-SPH | N34702510 | two-part - with double J hook | 2500 | 50 | 10000 |
| ZGR-50-2500-FE-SPH | N34702505 | Fixed end with ratchet and double J hook | 2500 | 50 | 400 |

INFO

Other end fittings (hooks) and individual prints on webbing are available on request.

Other lengths on request.

ZGZ-G-75-5000

Ratchet lashing

Made from polyester (PES), EN 12195-2
75 mm - lashing capacity LC 5000 daN.

Features

- Standard tension force STF 500 daN at standard hand force SHF 50 daN.
- with long lever-transmission - pull ratchet
- Standard lengths 2 m and 4 m.

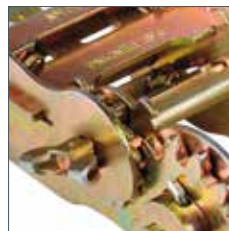

Long lever-transmission



SPH - with double J hook

Technical data ZGZ-G-75-5000

| Model | Art.-No. | Version | Lashing capacity LC daN | Webbing width mm | Length of lashing mm |
|---------------------|-----------|-------------------------------|-------------------------|------------------|----------------------|
| ZGZ-G-75-5000-1 | 192067448 | one-part | 5000 | 75 | 2000 |
| ZGZ-G-75-5000-1 | 192067450 | one-part | 5000 | 75 | 4000 |
| ZGZ-G-75-5000-2-SPH | 192017853 | two-part - with double J hook | 5000 | 75 | 2000 |
| ZGZ-G-75-5000-2-SPH | 192017854 | two-part - with double J hook | 5000 | 75 | 4000 |

INFO

Other end fittings (hooks) and individual prints on webbing are available on request.

Other lengths on request.



ZGR-XL-50-2500 Ratchet lashing with long lever push ratchet

Made from polyester (PES), EN 12195-2
50 mm - lashing capacity LC 2500 daN.

Features

- Standard tension force STF 500 daN at standard hand force SHF 50 daN.
- Long lever ratchet with precise interlocking.
- With device for controlled release (securing against tipping load).
- Standard lengths 8 m and 10 m.

Technical data ZGR-XL-50-2500 with device for controlled release

| Model | Art.-No. | Version | Lashing capacity LC daN | Webbing width mm | Length of lashing mm |
|----------------------|-----------|-------------------------------|-------------------------|------------------|----------------------|
| ZGR-XL-50-2500-1 | N34112580 | one-part | 2500 | 50 | 8000 |
| ZGR-XL-50-2500-1 | N34112510 | one-part | 2500 | 50 | 10000 |
| ZGR-XL-50-2500-2-GKH | N34212580 | two-part - with snap hook | 2500 | 50 | 8000 |
| ZGR-XL-50-2500-2-GKH | N34212510 | two-part - with snap hook | 2500 | 50 | 10000 |
| ZGR-XL-50-2500-2-KLH | N34312580 | two-part - with claw hook | 2500 | 50 | 8000 |
| ZGR-XL-50-2500-2-KLH | N34312510 | two-part - with claw hook | 2500 | 50 | 10000 |
| ZGR-XL-50-2500-2-SPH | N34712580 | two-part - with double J hook | 2500 | 50 | 8000 |
| ZGR-XL-50-2500-2-SPH | N34712510 | two-part - with double J hook | 2500 | 50 | 10000 |



Long lever ratchet
with precise interlocking. Device for controlled release (securing against tipping load).

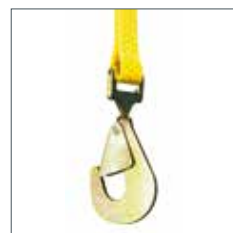

GKH - with twisted snap hook



SPH - with double J hook

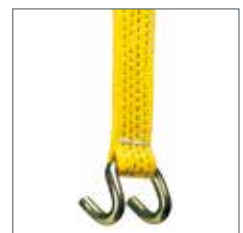

KLH - with claw hook

INFO

Other end fittings (hooks) and individual prints on webbing are available on request.

Other lengths on request.

ZGR-XLZ-50-2500 Ratchet lashing with long lever pull ratchet



Made from polyester (PES), EN 12195-2
50 mm - lashing capacity LC 2500 daN.

Features

- Standard tension force STF 500 daN at standard hand force SHF 50 daN.
- Long lever ratchet with precise interlocking.
- Ergonomic pull-type design
- Standard lengths 8 m and 10 m.

INFO

Other end fittings (hooks) and individual prints on webbing are available on request.

Other lengths on request.

Technical data ZGR-XLZ-50-2500 ergonomic pull-type design

| Model | Art.-No. | Version | Lashing capacity LC daN | Webbing width mm | Length of lashing mm |
|-----------------------|-----------|-------------------------------|-------------------------|------------------|----------------------|
| ZGR-XLZ-50-2500-1 | N34132580 | one-part | 2500 | 50 | 8000 |
| ZGR-XLZ-50-2500-1 | N34132510 | one-part | 2500 | 50 | 10000 |
| ZGR-XLZ-50-2500-2-GKH | N34232580 | two-part - with snap hook | 2500 | 50 | 8000 |
| ZGR-XLZ-50-2500-2-GKH | N34232510 | two-part - with snap hook | 2500 | 50 | 10000 |
| ZGR-XLZ-50-2500-2-KLH | N34332580 | two-part - with claw hook | 2500 | 50 | 8000 |
| ZGR-XLZ-50-2500-2-KLH | N34332510 | two-part - with claw hook | 2500 | 50 | 10000 |
| ZGR-XLZ-50-2500-2-SPH | N34732580 | two-part - with double J hook | 2500 | 50 | 8000 |
| ZGR-XLZ-50-2500-2-SPH | N34732510 | two-part - with claw hook | 2500 | 50 | 10000 |

ZGA Automatic ratchet lashing

Made from polyester, EN 12195-2

Features

- With automatic ratchet.
- Quick and precise fixing of load.
- Stepless adjustment.
- Easy rolling of webbing strap.
- PVC coated S-Hook to protect the loading space.



Technical data ZGA

| Model | Art.-No. | Version | Lashing capacity LC daN | Webbing width mm | Length of lashing mm |
|------------|-----------------|--|-------------------------|------------------|----------------------|
| ZGA-25-300 | N34799999-9681 | two-part - with plastic coated S hooks | 300 | 25 | 3000 |
| ZGA-50-750 | N34799999-11159 | two-part - with double J hook | 750 | 50 | 3000 |



ZGZB-RU-PU Ratchet base

Manufactured from cut resistant polyurethane.
Can also be used as edge protector.

Technical data ZGZB-RU-PU

| Model | Art.-No. | For webbing width mm |
|---------------|-----------|-------------------------|
| ZGZB-RU-PU-50 | N39150001 | 35 - 50 |
| ZGZB-RU-PU-75 | N39150002 | 75 |



ZGZB-KS-PP-50 Edge protector

Edge protector for lashing sensitive loads
(cardboard boxes etc.).

Technical data ZGZB-KS-PP-50

| Model | Art.-No. | For webbing width mm |
|---------------|-----------|-------------------------|
| ZGZB-KS-PP-50 | N39160003 | 50 |



ZGZB-KS-PP-70 Edge protector

Inherently stable edge protection, protects both load and
ratchet lashing.

Leg lengths 135 x 170 mm.

Technical data ZGZB-KS-PP-70

| Model | Art.-No. | For webbing width mm |
|---------------|-----------|-------------------------|
| ZGZB-KS-PP-70 | 192020360 | up to 70 |

ZGZB-KSP-PP Edge protector profile

Manufactured from polypropylene or recycled cardboard, to protect edges of loads. Length up to 6 m.



Technical data ZGZB-KSP-PP

| Model | Art.-No. | Dimensions mm |
|-------------|-----------|---------------|
| ZGZB-KSP-PP | N39160004 | 190 x 19 x 20 |

ZGZB-ARM Slip restraining mats

Manufactured from compressed rubber granulate to achieve a defined friction coefficient of $\mu = 0.6$. Even if an emergency stop or evasive action is being taken – the cargo trucks or train wagons must not move. But only in very few cases the vehicle structure alone will offer sufficient load security.

For this reason, slip restraining devices should belong to the standard equipment of every professional transport. Slip restraining mats will decrease the danger which emanates from plain loading platforms. They will reduce the required total pre-tensioning forces during over top lashing of loads and will contribute – together with the textile lashings – that the loads will form a single unit with the vehicle or wagon.

The slip restraining effect will benefit especially those products, which do not stand a high surface pressure. The dangers resulting from incorrect load lashing practices are often underestimated. Acceleration forces in standard driving situations are close to the dead weight of the load.



INFO

The friction force FW of a slip restraining mat impedes load displacement and is physically explained as follows:

$FW = m \times G$
 G = Weight force
 m = Friction value

The difference between inertial force F and friction force FW is called securing force FS .

$FS = F - FW$

The securing force FS is the strength which has to be absorbed by the safety devices.

Technical data ZGZB-ARM

| Model | Art.-No. | Dimensions mm |
|----------------|-----------|----------------|
| ZGZB-ARM-250-8 | N39170001 | 1000 x 250 x 8 |



RLSP Load binders

Lashing capacity 4000 - 10600 daN

The load binder is a universal tool to restrain and secure loads and freight. Manual operation of the binder lever extends or retracts the threaded spindles. Tension is upheld by the self-locking threads.

The load binder is fitted with shortening hooks for direct attachment to chains or with clevis ends for use with existing fastening devices.

Technical data RLSP

| Model | Art.-No. | Version | Lashing capacity LC daN | Weight kg |
|------------|-----------|------------------|-------------------------|-----------|
| RLSP-08-ÖÖ | N43300015 | Clevis | 4000 | 3.6 |
| RLSP-10-ÖÖ | N43300016 | Clevis | 6300 | 3.6 |
| RLSP-13-ÖÖ | N43300017 | Clevis | 10600 | 3.8 |
| RLSP-08-HH | N43300012 | Shortening hooks | 4000 | 4.5 |
| RLSP-10-HH | N43300013 | Shortening hooks | 6300 | 5.5 |
| RLSP-13-HH | N43300014 | Shortening hooks | 10600 | 8.4 |

Dimensions RLSP

| Model | RLSP-08-ÖÖ | RLSP-10-ÖÖ | RLSP-13-ÖÖ | RLSP-08-HH | RLSP-10-HH | RLSP-13-HH |
|----------------|------------|------------|------------|------------|------------|------------|
| Chain size, mm | 8 | 10 | 13 | 8 | 10 | 13 |
| B1, mm | 250 | 250 | 250 | 250 | 250 | 250 |
| B2 min., mm | 360 | 360 | 366 | 588 | 630 | 722 |
| B2 max., mm | 510 | 510 | 516 | 738 | 780 | 872 |
| Ø E, mm | 20 | 20 | 25 | - | - | - |
| L, mm | 230 | 230 | 360 | 190 | 230 | 360 |

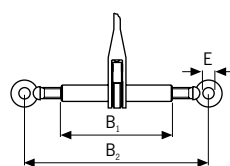

Load binder with protection against unscrewing, clevis acc. to EN 12195-3 on both ends.

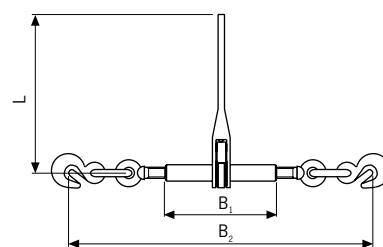

Load binder with protection against unscrewing, clevis or shortening hook with safety pin acc. to EN 12195-3 on both ends.

ASH

Weld-on hooks

Capacity 1000 - 8000 kg

Weld-on hooks model ASH are universal attachments for use on trucks, excavators, low loaders and spreader beams, etc. The forged safety latch has high lateral stability and an ergonomic shape. Every weld-on hook has an identification number so that its history can be traced back through forging to the origin of the material.

The hook can be welded without any special preparation, e.g. prewarming.

The hook and safety latch are epoxy resin coated for added corrosion protection, the return spring is made from stainless steel.



Technical data ASH

| Model | Art.-No. | Capacity kg | Weight kg |
|-------|-----------|-------------|-----------|
| ASH 1 | N41000104 | 1000 | 0.5 |
| ASH 3 | N41000035 | 3000 | 1.3 |
| ASH 5 | N41000036 | 5000 | 2.4 |
| ASH 8 | N41000037 | 8000 | 3.6 |

Dimensions ASH

| Model | ASH 1 | ASH 3 | ASH 5 | ASH 8 |
|--------------------|---------|----------|----------|----------|
| Seam density a, mm | 4 | 6 | 7 | 8 - 9 |
| L1 x B1, mm | 90 x 25 | 130 x 35 | 160 x 45 | 170 x 50 |
| B2, mm | 19 | 26 | 30 | 40 |
| C, mm | 24 | 32 | 40 | 51 |
| H1, mm | 6 | 10 | 12 | 12 |
| H2, mm | 76 | 117 | 121 | 142 |
| L2, mm | 22 | 29 | 47 | 52 |

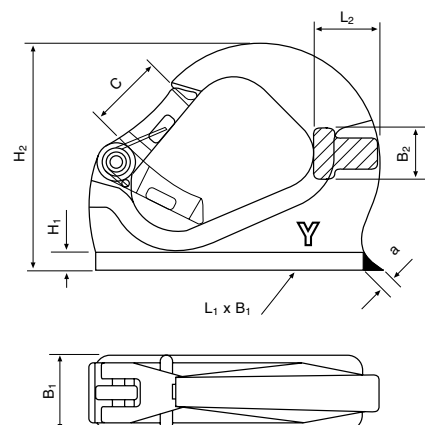

Material Handling Equipment

Pfaff-silberblau industrial trucks are ideal for transporting and stacking loads on pallets in factories.

The comprehensive range of products offers the correct model for numerous applications; be it for different route lengths or degrees of utilization, gradients and ramps or areas with a corrosion hazard.

From pallet trucks, manual stackers to electric stackers and elevating platforms – you will find the appropriate solution.

Load Moving Systems

Yale heavy load moving systems for the safe transportation of heavy loads of up to 100t.

Products range from separately used load moving skates to complete systems.

INFO

Please note our user instructions at the beginning of each chapter.

Table of contents

| | Page |
|---|-----------|
| Hand pallet trucks | 274 - 283 |
| Hand pallet trucks with weighing system | 284 - 285 |
| Scissor pallet trucks | 286 - 287 |
| Electric pallet trucks | 288 - 293 |
| Manual drive stackers | 294 - 301 |
| Electric pedestrian stackers | 302 - 310 |
| Elevating platforms | 311 - 321 |
| Load Moving Systems | 322 - 327 |

PFAFF
silberblau

MATERIAL HANDLING EQUIPMENT



OPERATION

This user information presents a general review regarding the application of material handling equipment and does not substitute the existing operating instructions for specific industrial trucks and elevating platforms!

Operating industrial trucks as well as lifting operations must be carried out by competent persons. When operated correctly, our products will offer the highest degree of safety, avoid damage to products and people and present a long life expectancy.

Modification of delivery condition

Design and construction of material handling products must not be altered by e.g. assembly of outside supplied components, bending, welding, grinding, cutting-off parts, adding boreholes, removal of safety devices or fitting of attachments.

Limitations of operation

Loading

The rated capacity (WLL) indicated on the product is the maximum load which must not be exceeded.

Transport of people

Transport of people with industrial trucks is generally forbidden!

Operation in danger zones

Lifting or transport of loads must be avoided while personnel are in the danger zone.

Do not allow people to stay on or below a raised load.

Do not place hands or feet under the raised fork frame or load on account of the imminent danger of crushing or shearing.

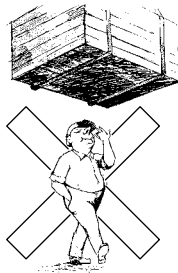

Inspection before starting work

- Prior to starting work, the unit must be inspected for obvious deficiencies and failures. Operational checks must be performed to ensure lifting, lowering and travel operate correctly.
- Check the parking brake is effective and the key switch operates correctly to protect against unauthorised use.
- Load carriage and forks must not show obvious defects (deflections, cracks or other wearing).
- Wheels and tires must not be defective.
- The hydraulic system must be in perfect order (lifting, lowering, density).
- The functional capability of the collision protective device should be checked.
- Battery charging status, fastening and cable connections of the battery as well as battery plug must be inspected for appropriate status as well as the battery cell lids (dry, clean).

Application advices

- Our material handling equipment must be operated on in-plant areas only.
- Only use industrial trucks in perfect condition and with legible identity plate.
- Industrial trucks may only be operated by skilled people, who have been instructed (in theory and practice) by the responsible user.
- The travel speed must conform to local conditions.
- Industrial trucks must be operated on flat, level and even ground.
- The operator must make sure that the load unit is in perfect condition and safely attached.
- Pallets may be transported individually only.
- Industrial trucks must not be used as car jacks.
- Industrial trucks must not be used in areas which are not illuminated sufficiently.
- Forks may not be used as levers.
- Loading of just one fork, e.g. for lifting of a machine, is strictly forbidden.
- Industrial trucks may not be operated in direct contact with foodstuffs.
- Never turn the hand lever 90° in order to stop the truck.
- The industrial truck must not be operated in explosive atmospheres (special versions on request).

Maintenance and repair

- To ensure safe operation, all material handling equipment must be subjected to regular inspections according to the maintenance instructions provided by the manufacturer.
- Material handling equipment, which is due for maintenance normally at least once per year, unless adverse working conditions dictate shorter periods.
- Inspections and repairs must be performed by competent persons or specialist workshops that use original spare parts. Inspections and repairs have to be recorded consecutively.

Inspections

- Inspections are visual and functional and shall establish that the product has not been damaged by incorrect transport or storage. In addition check for damage, wear, corrosion or other deficiencies as well as completeness and function safety devices. Inspections are instigated by the user.
- Material handling products have to be cleaned prior to inspection. The cleaning procedure must not cause chemical damages (e.g. no acid – embrittlement) no incorrect temperature stress by e.g. flame cleaning or possible concealment of cracks due to excessive material abrasion (sand blasting).
We shall be pleased to consult you in this respect!
- **Inspection of fork frame**
The fork frame has to be checked regularly for obvious defects, deformations and cracks as well as wear and corrosion.
- **Inspection of control handle**
The control handle must be checked regularly for obvious defects, deformations, cracks. Moreover, check screws for fixed seat.
- **Inspection of oil level**
Check oil level every six months (oil viscosity 30 Cst at 40 °C). At ambient temperature around 0 °C we recommend AVILUB RSL 22.
- **Inspection of lubrication and density**
Bolts, axles and push rods should be cleaned and lubricated depending on application with e.g. Shell FD or comparable grease.
- The hydraulic unit has to be checked regularly for density.





Load diagrams
for residual carrying capacities

EHH PSE 10-30

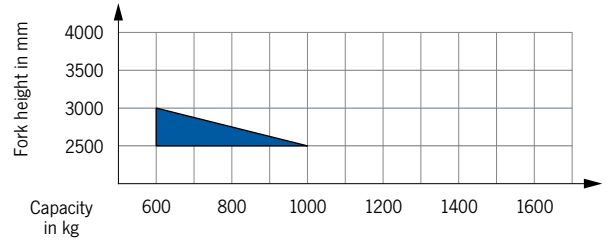

EHH PS 12-25/12-29/12-35

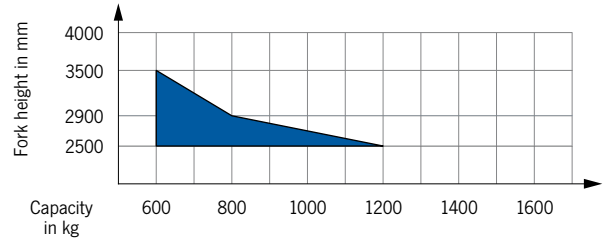

EGV PSL 12-25 II/12-29 II/12-35 II

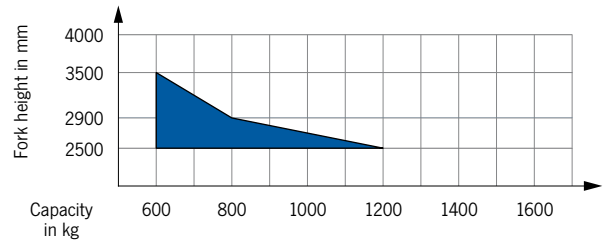

EGV PSH 14-45 TII/14-45 TFII

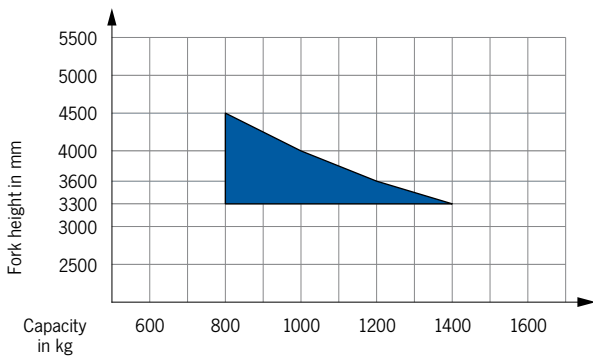

EGV PSH 14-50 TII

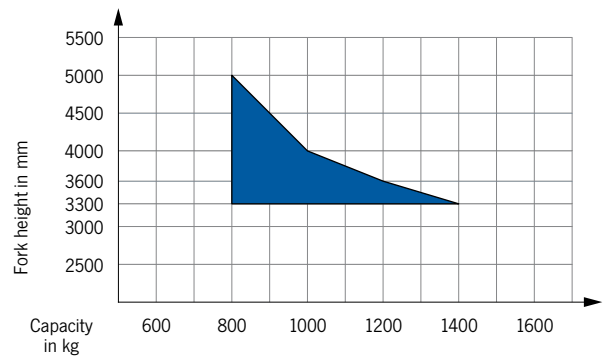

EGV PSH 12-25 II/12-29 II/12-35 II

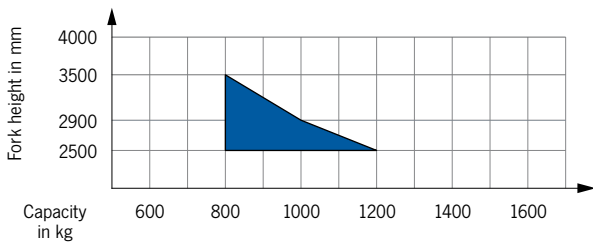

EGV PSH 16-25 II/16-29 II/16-35 II

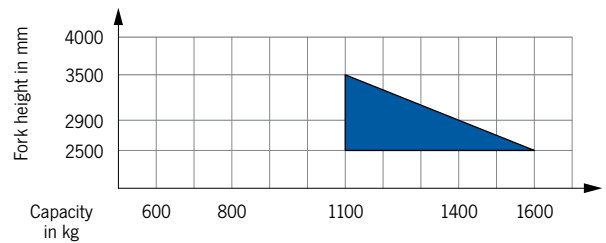

Technical questionnaire to identify a suitable material handling product

Company: _____ Date: _____

Contact: _____ e-Mail: _____

Phone: _____ Fax: _____

Capacity _____ kg

Fork height max. _____ mm

Freelift _____ mm

Required residual lifting

capacity _____ mm

At fork height _____ mm

Headroom with mast retracted _____ mm

Lifting

manual-hydraulic

electric-hydraulic

Drive

manual

electric

Transport and stacking of:

palletised goods

long goods

loading lorries

Special requests

Lengths of application per shift

up to 2 hours

up to 4 hours

up to 6 hours

up to 8 hours

Shifts per day

Drivers platform

yes

no





HU 25-115 TS SILVERLINE
Hand pallet truck
(Tandem rollers)

HU 25-115 ES SILVERLINE
Hand pallet truck
(Single rollers)

Capacity 2500 kg

For the professional transportation of palletised goods and box pallets under demanding conditions.

Features

- Ergonomic safety control handle for one-hand operation of lifting, driving and lowering.
- Ergonomic rubber control handle for safe handling.
- Low maintenance hydraulic pump with hard chromium plated piston.
- Frame and forks in robust steel construction, adjustable connecting rods, especially hardened axles and the high quality powder coating ensure a long life expectancy.



Option: Parking brake

Technical data HU 25-115 TS SILVERLINE and HU 25-115 ES SILVERLINE

| Model | HU 25-115 TS | HU 25-115 TS | HU 25-115 TS | HU 25-115 TS | HU 25-115 TS | HU 25-115 ES |
|-----------------------------------|--------------|--------------|--------------|--------------|--------------|--------------|
| Art.-No. | N21225460 | N21225461 | N21225462 | N21225463 | N21225464 | N21225220 |
| Capacity, kg | 2500 | 2500 | 2500 | 2500 | 2500 | 2500 |
| Load center c, mm | 600 | 600 | 600 | 600 | 600 | 600 |
| Weight, kg | 70 | 68 | 69 | 65 | 70 | 67 |
| Tyre type ¹ | VG/PA | VG/PUR | PUR/PUR | PA/PA | PUR/PA | VG/PUR |
| Steering rollers, mm | 200 x 50 | 200 x 50 | 200 x 50 | 200 x 50 | 200 x 50 | 200 x 50 |
| Load rollers, mm | 80 x 70 | 80 x 70 | 80 x 70 | 80 x 70 | 80 x 70 | 80 x 93 |
| Number of wheels/load rollers | 2/4 | 2/4 | 2/4 | 2/4 | 2/4 | 2/2 |
| Stroke h3, mm | 115 | 115 | 115 | 115 | 115 | 115 |
| Height of control handle h14, mm | 1230 | 1230 | 1230 | 1230 | 1230 | 1230 |
| Fork height lowered h13, mm | 85 | 85 | 85 | 85 | 85 | 85 |
| Overall length L1, mm | 1555 | 1555 | 1555 | 1555 | 1555 | 1555 |
| Fork height s, mm | 48 | 48 | 48 | 48 | 48 | 48 |
| Fork width e, mm | 160 | 160 | 160 | 160 | 160 | 160 |
| Fork length l, mm | 1150 | 1150 | 1150 | 1150 | 1150 | 1150 |
| Outside dimension of forks b1, mm | 540 | 540 | 540 | 540 | 540 | 540 |
| Inside dimension of forks b3, mm | 220 | 220 | 220 | 220 | 220 | 220 |
| Ground clearance m1, mm | 37 | 37 | 37 | 37 | 37 | 37 |
| Aisle width pallet Ast, mm | 1793 | 1793 | 1793 | 1793 | 1793 | 1793 |
| Turning circle radius Wa, mm | 1275 | 1275 | 1275 | 1275 | 1275 | 1275 |

¹PA... Polyamide, PUR... Polyurethane, VG... Solid rubber

HU 20-115 VATP PROLINE Hand pallet truck stainless steel version

Capacity 2000 kg

For the professional transportation of palletised goods in corrosive areas.

Features

- Ergonomic safety control handle for one-hand operation of lifting, driving and lowering.
- Low maintenance high performance hydraulic pump with hard chromium plated piston and pressure relief valve. Hydraulic unit made of stainless steel resp. bronze (HU 25-115 VATP).
- Frame, adjustable connecting rods, bolts and the torsion tube are made of high quality stainless steel.
- Steering angle of 105 degree to each side for easy handling in confined spaces.



INFO

The operator is responsible for an analysis of the working conditions in order to assess the suitability of the hand pallet truck.

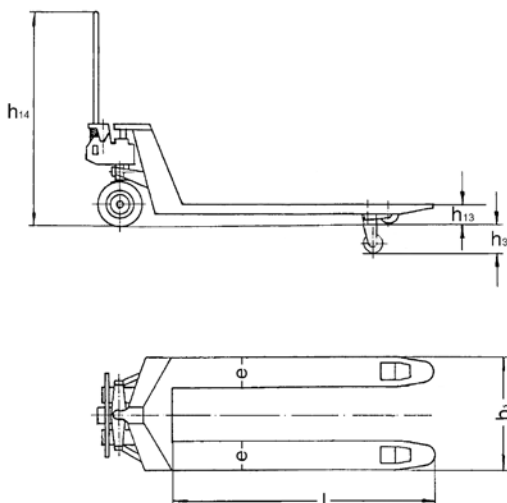

Technical data HU stainless steel version

| Model | HU 20-115 VATP |
|-----------------------------------|----------------|
| Art.-No. | 40005740 |
| Material | V4A/316 |
| Capacity, kg | 2000 |
| Weight, kg | 86 |
| Tyre type ¹ | PA/PA |
| Steering rollers, mm | 200 x 50 |
| Load rollers, mm | 82 x 70 |
| Stroke h3, mm | 115 |
| Height of control handle h14, mm | 1200 |
| Fork height lowered h13, mm | 85 |
| Fork width e, mm | 160 |
| Fork length l, mm | 1150 |
| Outside dimension of forks b1, mm | 540 |

¹PA... Polyamide



Hand pallet truck SILVERLINE with a smaller or a wider loading width

Capacity 1500 - 2500 kg

For the professional transportation of special pallets, e.g. brickyard pallets or american pallets.

Features

- Ergonomic safety control handle for one-hand operation of lifting, driving and lowering.
- Ergonomic rubber control handle for safe handling.
- Low maintenance high performance hydraulic pump with hard chromium plated piston and pressure relief valve.
- Frame and forks in robust steel construction, adjustable connecting rods, especially hardened axles and the high quality powder coating ensure a long life expectancy.
- Steering angle of 105 degree to each side for easy handling in confined spaces.



Option: Parking brake

Technical data hand pallet truck SILVERLINE

| Model | HU 15-115 TP | HU 20-115 BTS | HU 25-115 BTS |
|-----------------------------------|--------------|---------------|---------------|
| Art.-No. | 40006498 | 34527132 | N21225457 |
| Capacity, kg | 1500 | 2000 | 2500 |
| Weight, kg | 80 | 86 | 73 |
| Tyre type ¹ | PUR/PUR | VG/PUR | VG/PUR |
| Steering rollers, mm | 200 x 50 | 200 x 50 | 200 x 50 |
| Load rollers, mm | 82 x 70 | 82 x 70 | 80 x 70 |
| Stroke h3, mm | 115 | 115 | 115 |
| Height of control handle h14, mm | 1200 | 1200 | 1230 |
| Fork height lowered h13, mm | 85 | 85 | 85 |
| Fork width e, mm | 160 | 160 | 160 |
| Fork length l, mm | 1150 | 1150 | 1150 |
| Outside dimension of forks b1, mm | 450 | 850 | 685 |

¹PUR... Polyurethane, VG... Solid rubber

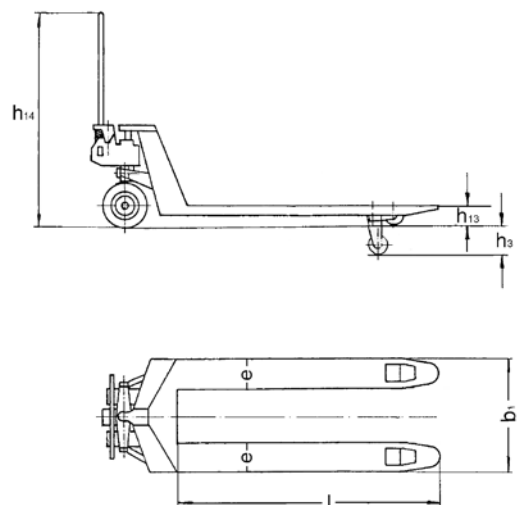

HU 15-115 FTP PROLINE Hand pallet truck with low height forks

Capacity 1500 kg

For the professional transportation of particularly low pallets.

Features

- Ergonomic safety control handle for one-hand operation of lifting, driving and lowering.
- Ergonomic rubber control handle for safe handling.
- Low maintenance high performance hydraulic pump with hard chromium plated piston and pressure relief valve.
- Frame and forks in robust steel construction, adjustable connecting rods, especially hardened axles and the high quality powder coating ensure a long life expectancy.
- Pallet entry height of only 51 mm for easy entry in particularly low pallets.
- Steering angle of 105 degree to each side for easy handling in confined spaces.



Technical data HU 15-115 FTP

| Model | HU 15-115 FTP |
|-----------------------------------|---------------|
| Art.-No. | 34527124 |
| Capacity, kg | 1500 |
| Weight, kg | 84 |
| Tyre type ¹ | PUR/PA |
| Steering rollers, mm | 180 x 50 |
| Load rollers, mm | 50 x 70 |
| Stroke h3, mm | 115 |
| Height of control handle h14, mm | 1200 |
| Fork height lowered h13, mm | 51 |
| Fork width e, mm | 160 |
| Fork length l, mm | 1150 |
| Outside dimension of forks b1, mm | 540 |

¹PUR... Polyurethane, PA... Polyamide

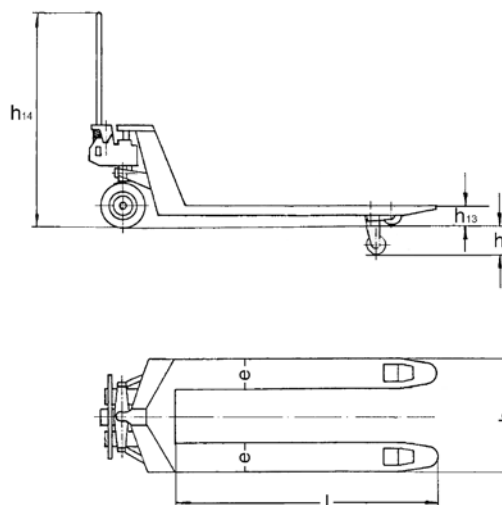

Hand pallet truck PROLINE with short forks

Capacity 2500 kg

For the professional transportation of short palletised goods and box pallets under demanding conditions.

Features

- Ergonomic safety control handle for one-hand operation of lifting, driving and lowering.
- Ergonomic rubber control handle for safe handling.
- Low maintenance high performance hydraulic pump with hard chromium plated piston and pressure relief valve.
- Frame and forks in robust steel construction, adjustable connecting rods, especially hardened axles and the high quality powder coating ensure a long life expectancy.
- Fork lengths from 600 up to 1000 mm for transportation of small loads.
- Steering angle of 105 degree to each side for easy handling in confined spaces.
- Available with tandem (TP) or single rollers (EP).



Technical data hand pallet truck PROLINE with short forks

| Model | HU 25-60 EP | HU 25-80 EP | HU 25-80 TP | HU 25-90 TP | HU 25-100 TP |
|-----------------------------------|-------------|-------------|-------------|-------------|--------------|
| Art.-No. | 40011694 | N21225221 | N21225450 | N21225451 | N21225452 |
| Capacity, kg | 2500 | 2500 | 2500 | 2500 | 2500 |
| Weight, kg | 59 | 63 | 64 | 67 | 66 |
| Tyre type ¹ | VG/PA | VG/PUR | VG/PUR | VG/PUR | VG/PUR |
| Steering rollers, mm | 200 x 50 | 200 x 50 | 200 x 50 | 200 x 50 | 200 x 50 |
| Load rollers, mm | 82 x 70 | 80 x 93 | 80 x 70 | 80 x 70 | 80 x 70 |
| Stroke h3, mm | 115 | 115 | 115 | 115 | 115 |
| Height of control handle h14, mm | 1200 | 1230 | 1230 | 1230 | 1230 |
| Fork height lowered h13, mm | 85 | 85 | 85 | 85 | 85 |
| Fork width e, mm | 160 | 160 | 160 | 160 | 160 |
| Fork length l, mm | 600 | 800 | 800 | 900 | 1000 |
| Outside dimension of forks b1, mm | 540 | 540 | 540 | 540 | 540 |

¹PA... Polyamide, PUR... Polyurethane, VG... Solid rubber

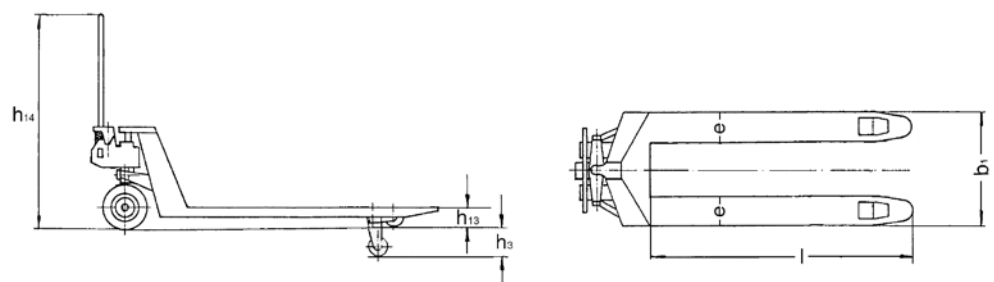

Hand pallet truck PROLINE for heavy loads

Capacity 3000 kg

For the professional transportation of heavy loads.

Features

- Ergonomic safety control handle for one-hand operation of lifting, driving and lowering.
- Ergonomic rubber control handle for safe handling.
- Low maintenance high performance hydraulic pump with hard chromium plated piston and pressure relief valve.
- Frame and forks in robust steel construction, adjustable connecting rods, especially hardened axles and the high quality powder coating ensure a long life expectancy.



Technical data hand pallet truck PROLINE for heavy loads

| Model | HU 30-115 TP |
|-----------------------------------|--------------|
| Art.-No. | N21230415 |
| Capacity, kg | 3000 |
| Weight, kg | 73 |
| Tyre type ¹ | PUR/PUR |
| Steering rollers, mm | 200 x 50 |
| Load rollers, mm | 80 x 70 |
| Stroke h3, mm | 115 |
| Height of control handle h14, mm | 1230 |
| Fork height lowered h13, mm | 85 |
| Fork width e, mm | 160 |
| Fork length l, mm | 1150 |
| Outside dimension of forks b1, mm | 540 |

¹PUR... Polyurethane

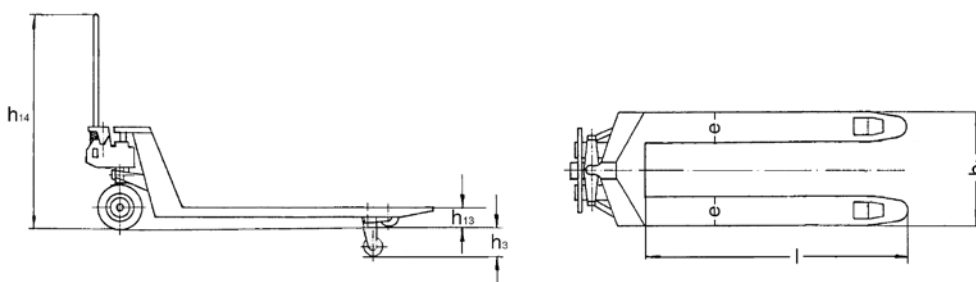

Hand pallet truck PROLINE with extended forks

Capacity 2000 - 2500 kg

For the professional transportation of long palletised goods and box pallets under demanding conditions.

Features

- Ergonomic safety control handle for one-hand operation of lifting, driving and lowering.
- Ergonomic rubber control handle for safe handling.
- Low maintenance high performance hydraulic pump with hard chromium plated piston and pressure relief valve.
- Frame and forks in robust steel construction, adjustable connecting rods, especially hardened axles and the high quality powder coating ensure a long life expectancy.
- Fork lengths from 1300 up to 3000mm for transportation of long and bulky loads.
- Steering angle of 105 degree to each side for easy handling in confined spaces.



Option: Parking brake

INFO

Driving and parking brake available as option.

Technical data hand pallet truck PROLINE with extended forks

| Model | HU 25-130 TP | HU 20-150 TP | HU 20-180 TP | HU 20-200 TP | HU 20-250 TP |
|-----------------------------------|--------------|--------------|--------------|--------------|--------------|
| Art.-No. | N21225453 | N21225454 | N21225455 | N21225456 | 34527202 |
| Capacity, kg | 2500 | 2000 | 2000 | 2000 | 2000 |
| Weight, kg | 81 | 82 | 92 | 97 | 275 |
| Tyre type ¹ | VG/PUR | VG/PUR | VG/PUR | VG/PUR | PUR/PUR |
| Steering rollers, mm | 200 x 50 | 200 x 50 | 200 x 50 | 200 x 50 | 200 x 50 |
| Load rollers, mm | 80 x 70 | 80 x 70 | 80 x 70 | 80 x 70 | 82 x 70 |
| Stroke h3, mm | 115 | 115 | 115 | 115 | 115 |
| Height of control handle h14, mm | 1230 | 1230 | 1230 | 1230 | 1200 |
| Fork height lowered h13, mm | 85 | 85 | 85 | 85 | 85 |
| Fork width e, mm | 160 | 160 | 160 | 160 | 170 |
| Fork length l, mm | 1300 | 1500 | 1800 | 2000 | 2500 |
| Outside dimension of forks b1, mm | 540 | 540 | 540 | 540 | 550 |

¹PUR... Polyurethane, VG... Solid rubber Other versions available on request

Hand pallet truck PROLINE with extended forks and increased capacity

Capacity 3000 - 3500 kg

For the professional transportation of long palletised goods and box pallets under demanding conditions.

Features

- Ergonomic safety control handle for one-hand operation of lifting, driving and lowering.
- Ergonomic rubber control handle for safe handling.
- Low maintenance high performance hydraulic pump with hard chromium plated piston and pressure relief valve.
- Frame and forks in robust steel construction, adjustable connecting rods, especially hardened axles and the high quality powder coating ensure a long life expectancy.
- Fork lengths from 1500 up to 2000 mm for transportation of long goods.
- Steering angle of 105 degree to each side for easy handling in confined spaces.



INFO

With extended forks up to 2000 mm and increased capacity up to 3500 kg.

Technical data hand pallet truck PROLINE with extended forks and increased capacity

| Model | HU 30-150 TP | HU 35-180 TP | HU 35-200 TP |
|-----------------------------------|--------------|--------------|--------------|
| Art.-No. | 34527204 | 34527205 | 34527206 |
| Capacity, kg | 3000 | 3500 | 3500 |
| Weight, kg | 121 | 139 | 148 |
| Tyre type ¹ | PUR/PUR | PUR/PUR | PUR/PUR |
| Steering rollers, mm | 200 x 50 | 200 x 50 | 200 x 50 |
| Load rollers, mm | 82 x 70 | 82 x 70 | 82 x 70 |
| Stroke h3, mm | 115 | 115 | 115 |
| Height of control handle h14, mm | 1200 | 1200 | 1200 |
| Fork height lowered h13, mm | 85 | 85 | 85 |
| Fork width e, mm | 160 | 170 | 170 |
| Fork length l, mm | 1500 | 1800 | 2000 |
| Outside dimension of forks b1, mm | 540 | 550 | 550 |

¹PUR... Polyurethane

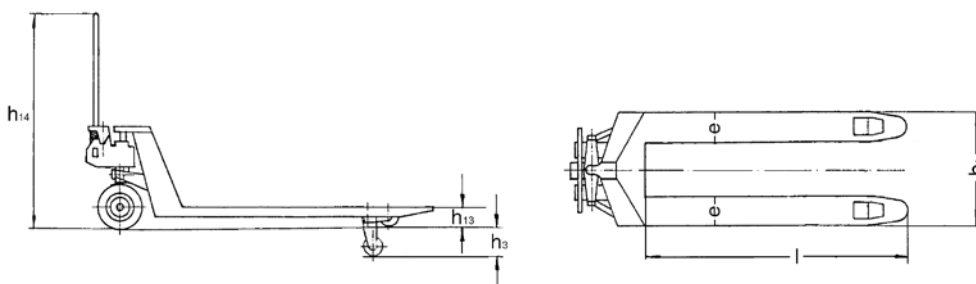

HU 20-115 QLTP PROLINE Hand pallet truck with quick-lift

Capacity 2000 kg

For quick lifting and professional transportation of palletised goods and box pallets under demanding conditions.

Features

- Ergonomic safety control handle for one-hand operation of lifting, driving and lowering.
- Ergonomic rubber control handle for safe handling.
- Low maintenance high performance hydraulic pump with hard chromium plated piston and pressure relief valve.
- Quick-lift function for loads up to 200 kg for quick lifting of the load.
- Frame and forks in robust steel construction, adjustable connecting rods, especially hardened axles and the high quality powder coating ensure a long life expectancy.
- Steering angle of 105 degree to each side for easy handling in confined spaces.

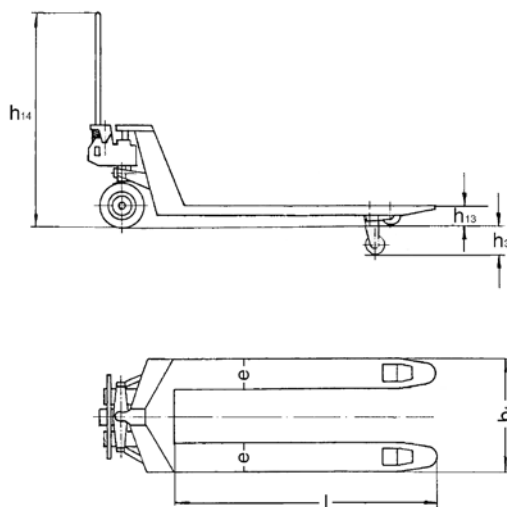

Technical data HU 20-115 QLTP

| Model | HU 20-115 QLTP |
|-----------------------------------|----------------|
| Art.-No. | N21225458 |
| Capacity, kg | 2000 |
| Weight, kg | 86 |
| Tyre type ¹ | VG/PUR |
| Steering rollers, mm | 200 x 50 |
| Load rollers, mm | 82 x 70 |
| Stroke h3, mm | 115 |
| Height of control handle h14, mm | 1200 |
| Fork height lowered h13, mm | 85 |
| Fork width e, mm | 160 |
| Fork length l, mm | 1150 |
| Outside dimension of forks b1, mm | 540 |

¹PUR... Polyurethane, VG... Solid rubber

HU 25-115 FBTP PROLINE Hand pallet truck with driving and parking brake

Capacity 2500 kg

For the professional transportation of palletised goods and box pallets, on ramps, ascending slopes and on lorries.

Features

- Ergonomic safety control handle for one-hand operation of lifting, driving and lowering.
- Ergonomic rubber control handle for safe handling.
- Driving and park brake comfortably operated from the control handle.
- Low maintenance high performance hydraulic pump with hard chromium plated piston and pressure relief valve.
- Frame and forks in robust steel construction, adjustable connecting rods, especially hardened axles and the high quality powder coating ensure a long life expectancy.
- Steering angle of 105 degree to each side for easy handling in confined spaces.



Technical data 25-115 FBTP

| Model | HU 25-115 FBTP |
|-----------------------------------|----------------|
| Art.-No. | 34527135 |
| Capacity, kg | 2500 |
| Weight, kg | 86 |
| Tyre type ¹ | VG/PUR |
| Steering rollers, mm | 180 x 50 |
| Load rollers, mm | 82 x 70 |
| Stroke h3, mm | 115 |
| Height of control handle h14, mm | 1200 |
| Fork height lowered h13, mm | 85 |
| Fork width e, mm | 160 |
| Fork length l, mm | 1150 |
| Outside dimension of forks b1, mm | 540 |

¹PUR... Polyurethane, VG... Solid rubber

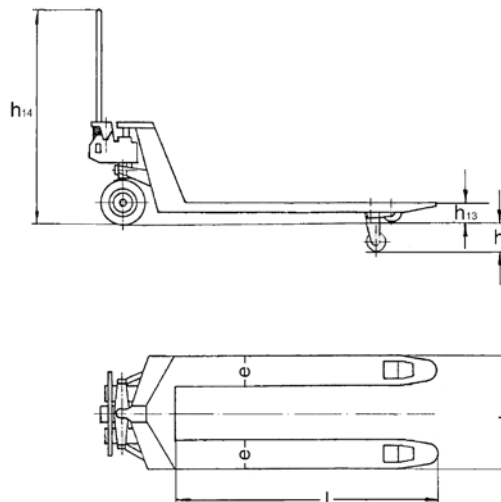



HU W-20 SL SILVERLINE
Hand pallet truck
with weighing system

Capacity 2000 kg

For transportation and weighing of palletised goods and box pallets. For simple weighing jobs and a rough calculation of total weights, e.g. when loading lorries.

Features

- The basic truck is the model Silverline HU 25-115.
- Ergonomic safety control handle for one-hand operation of lifting, driving and lowering.
- Ergonomic rubber control handle for safe handling.
- Measuring range from 0 up to 2000 kg in 5 kg steps.
- Easy to read LCD display.
- Accuracy:
 - 0 - 1000 kg → ± 20 kg
 - 1000 - 2000 kg → ± 40 kg

Scope of delivery

- 2 x 1.5 V AA batteries
 (sufficient for approx. 3000 weighing operations)

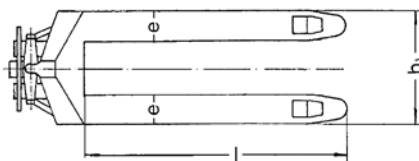
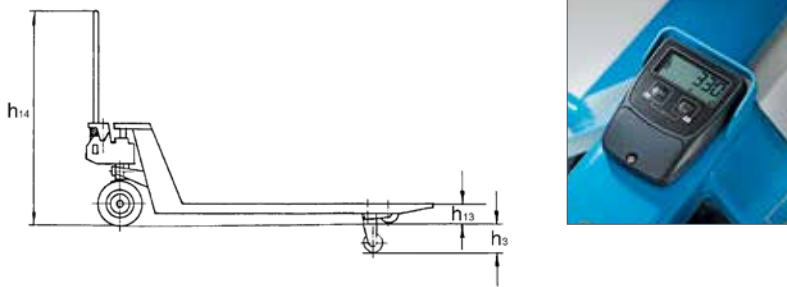

Technical data HU W-20 SL

| Model | HU W 20 SL |
|-----------------------------------|--------------------|
| Art.-No. | 40048616 |
| Capacity, kg | 2000 |
| Load center c, mm | 600 |
| Weight, kg | 76 |
| Tyre type ¹ | VG/PUR |
| Steering rollers D, mm | 200 x 50 |
| Load rollers D1, mm | 82 x 70 |
| Number of wheels/load rollers | 2/4 |
| Stroke h2, mm | 115 |
| Lifting height h3, mm | 200 |
| Height of control handle h14, mm | 1200 |
| Fork height lowered h13, mm | 85 |
| Overall length L1, mm | 1535 |
| Fork height s, mm | 45 |
| Fork width e, mm | 160 |
| Fork length l, mm | 1150 |
| Outside dimension of forks b1, mm | 540 |
| Ground clearance m1, mm | 40 |
| Turning circle radius, mm | 1330 |
| Ambient temperature | -5 °C up to +40 °C |

¹VG... Solid rubber, PUR... Polyurethane

HU W-20 S SILVERLINE

Hand pallet truck

-with weighing system

HU W-20 SPR SILVERLINE

-with weighing system and printer

Capacity 2000 kg

For transportation and weighing of palletised goods and box pallets

Features

- Ergonomic safety control handle for one-hand operation of lifting, driving and lowering.
- Ergonomic rubber control handle for safe handling.
- Measuring range from 0 up to 2000 kg in 1 kg steps.
- Easy to read LCD display.
- Accuracy $\pm 0.1\%$ of the end value.
- The readings start at 1.0 kg.
- The system is designed for simple weighing jobs, such as batching or filling processes.
- Low maintenance hydraulic pump with hard chromium plated piston and pressure relief valve.
- Frame and forks in robust steel construction, adjustable connecting rods, especially hardened axles and the high quality powder coating ensure a long life expectancy.
- Steering angle of 105 degree to each side for easy handling in confined spaces.

Scope of delivery

- 4 x 1.5 V AA batteries
(sufficient for approx. 3000 weighing operations)



HU W-20 SPR SILVERLINE
with weighing system and printer

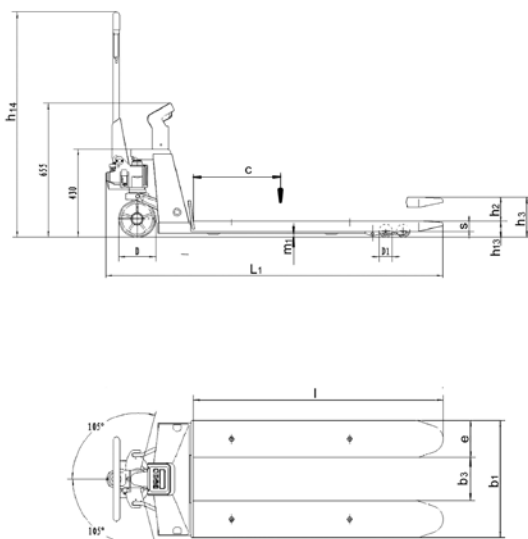

Technical data HU W-20 S and HU W-20 SPR

| Model | HU W 20 S | HU W 20 SPR |
|-----------------------------------|---------------------|---------------------|
| Art.-No. | 40016431 | N21220615 |
| Capacity, kg | 2000 | 2000 |
| Load center c, mm | 600 | 600 |
| Weight, kg | 129 | 131 |
| Tyre type ¹ | PUR/PUR | PUR/PUR |
| Steering rollers D, mm | 180 x 50 | 180 x 50 |
| Load rollers D1, mm | 74 x 70 | 74 x 70 |
| Number of wheels/load rollers | 2/4 | 2/4 |
| Stroke h2, mm | 110 | 110 |
| Lifting height h3, mm | 195 | 195 |
| Height of control handle h14, mm | 1210 | 1210 |
| Fork height lowered h13, mm | 85 | 85 |
| Overall length L1, mm | 1580 | 1580 |
| Fork height s, mm | 50 | 50 |
| Fork width e, mm | 180 | 180 |
| Fork length l, mm | 1150 | 1150 |
| Outside dimension of forks b1, mm | 570 | 570 |
| Inside dimension of forks b3, mm | 210 | 210 |
| Ground clearance m1, mm | 35 | 35 |
| Turning circle radius, mm | 1330 | 1330 |
| Ambient temperature | -10 °C up to +40 °C | -10 °C up to +40 °C |

¹PUR... Polyurethane



HU HS 10 B
Scissor pallet truck
with manual-hydraulic lift

Capacity 1000 kg,
 fork height max. 800 mm

A combination of hand pallet truck and elevating platform for the transport and raising of palletised loads to various departments.

Features

- Safety control handle with the functions:
 Quick-lift - lifting - lowering.
- Lowering speed can be finely metered for sensitive lowering of the load.
- One-stage hydraulic for increased robustness.
- Overload protection by pressure relief valve.
- Safety supports guarantee sure standing when the forks are raised.
- Low noise and smooth running with standard tyres:
 steer rollers and load rollers – polyurethane.

Technical data HU HS 10 B

| Model | HU HS 10 B |
|---|------------|
| Art.-No. | N26600020 |
| Capacity Q, kg | 1000 |
| Load center c, mm | 600 |
| Weight, kg | 122 |
| Tyre type ¹ | PUR/PUR |
| Steering rollers, mm | 180 x 50 |
| Load rollers, mm | 75 x 50 |
| Number of wheels/load rollers | 2/2 |
| Stroke h3, mm | 715 |
| Height of control handle max. h14, mm | 1254 |
| Fork height lowered h13, mm | 85 |
| Overall length l1, mm | 1725 |
| Overall width b1/b2, mm | 575 |
| Fork height s, mm | 45 |
| Fork width e, mm | 160 |
| Fork length l, mm | 1170 |
| Outside dimension of forks b5, mm | 540 |
| Ground clearance, wheelbase centre m2, mm | 18 |
| Aisle width pallet Ast, mm | 1986 |
| Turning circle radius Wa, mm | 1564 |

¹PUR... Polyurethane

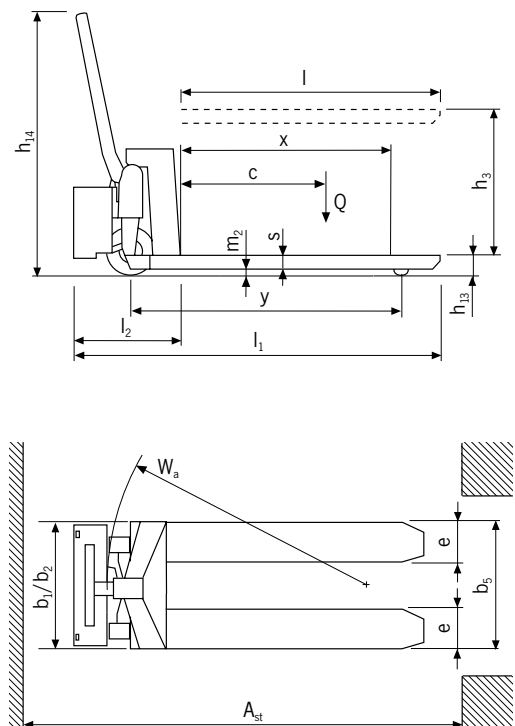

HU ES 10 B Scissor pallet truck with electric-hydraulic lift

Capacity 1000 kg,
fork height max. 800 mm

The HU ES 10 B increases the usefulness of the HU HS 10 B by saving operating time for demanding applications with frequent lifting and lowering operations.

Features

- Ergonomic control button for the hydraulic unit fitted in the handle.
- In case of a battery failure the manual use of lifting and lowering is still guaranteed.
- Quick electric-hydraulic lifting of the load, pressure relief valve protects against overloading.
- Low noise and smooth running due to polyurethane steering and load rollers as standard.
- Additional tilting protection for the load rollers.

Scope of delivery

- Battery and integrated battery charger

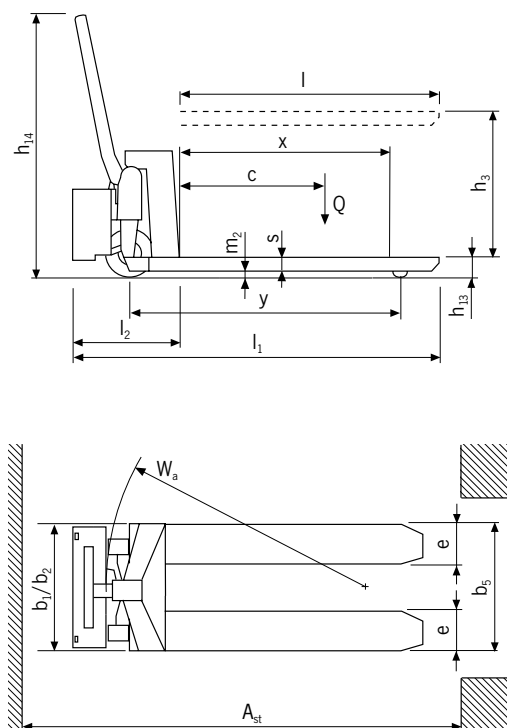

Technical data HU ES 10 B

| Model | HU ES 10 B |
|---|------------|
| Art.-No. | N26900020 |
| Capacity Q, kg | 1000 |
| Load center c, mm | 600 |
| Weight, kg | 152 |
| Tyre type ¹ | PUR/PUR |
| Steering rollers, mm | 180 x 50 |
| Load rollers, mm | 75 x 50 |
| Number of wheels/load rollers | 2/2 |
| Stroke h3, mm | 715 |
| Height of control handle max. h14, mm | 1254 |
| Fork height lowered h13, mm | 85 |
| Overall length l1, mm | 1715 |
| Overall width b1/b2, mm | 575 |
| Fork height s, mm | 45 |
| Fork width e, mm | 160 |
| Fork length l, mm | 1170 |
| Outside dimension of forks b5, mm | 540 |
| Ground clearance, wheelbase centre m2, mm | 18 |
| Aisle width pallet Ast, mm | 1986 |
| Turning circle radius Wa, mm | 1564 |
| Battery charger, V/A | 220/6 |
| Battery voltage, capacity K5, V/Ah | 12/52 |

¹PUR... Polyurethane



HU 12-115 TP *Li-ION* Hand pallet truck with electric drive

Capacity 1200 kg

For the transport of palletised goods in the in-house area, on flat floors and short to medium distances.

Reduced noise emission, compact size and small turning radius make it the ideal helper for supermarkets, retailers and workshops.

Supplied as standard with a replaceable battery, the discharged battery can be exchanged with a fully charged battery within seconds, minimising the amount of disruption to the work cycle (second battery as option).

Features

- 2 traction wheels for better traction and longer lifetime
- Maintenance-free rechargeable Lithium battery for quick charging
- Charging time of only 2.5 hours – 80% within 1 hour
- Infinitely variable driving speed
- Switchable between electric and manual drive
- highest speed of its class
- key switch for locking the truck
- non marking traction wheels
- turning radius of 1382 mm only - identical to the normal truck
- 5% gradient with load
- External charger for quick charging with a 230V plug socket

Scope of delivery

- 1 Li-ION Akku 36Volt, 10.4 A
- External charger

Li-ION battery

This battery offers much longer operational periods and overall lifetime with shorter charges.

- The Li-ION battery has a lifespan of up to 3000 charging cycles.
- Charging time of only 2.5 hours.
- Intermediate charge is possible without affecting the lifetime of the battery.
- No loss of power when the battery charge state drops.



User panel



Key switch

Technical data HU 12-115 TP Li-ION

| Model | HU 12-115 TP <i>Li-ION</i> |
|--|----------------------------|
| Art.-No. | N23312431 |
| Capacity, kg | 1200 |
| Tyre type ¹ | VG/PUR |
| Steering rollers l x d, mm | 200 x 40 |
| Load rollers l x d, mm | 82 x 60 |
| Number of wheels/load rollers (x=driven) | 2x/4 |
| Wheelbase Y, mm | 1192 |
| Stroke h3, mm | 115 |
| Load center c, mm | 600 |
| Fork height max., mm | 200 |
| Fork height lowered, mm | 85 |
| Height of control handle max. h14, mm | 1185 |
| Overall length l1, mm | 1600 |
| Length incl. apron l2, mm | 450 |
| Overall width b1, mm | 525 |
| Fork dimensions s/e/l, mm | 55 x 150 x 1150 |
| Outside dimension of forks b5, mm | 525 |
| Aisle width pallet Ast, mm | 2063 |
| Turning circle radius Wa, mm | 1382 |
| Actuation | electric |
| Operation | pedestrian |
| Travel speed with/without load, km/h | 4.2/5.3 |
| Lowering speed with/without load, m/s | 0.01/0.02 |
| Gradient with/without load, % | 5/10 |
| Drive motor rating, kW | 2 x 0.25 |
| Service brake | electric |
| Battery | Li-ION |
| Battery voltage 20 h, in V/Ah | 36/10.4 |
| Weight with battery, kg | 88 |

¹VG... Solid rubber, PUR... Polyurethane



Fast battery change – with a single touch

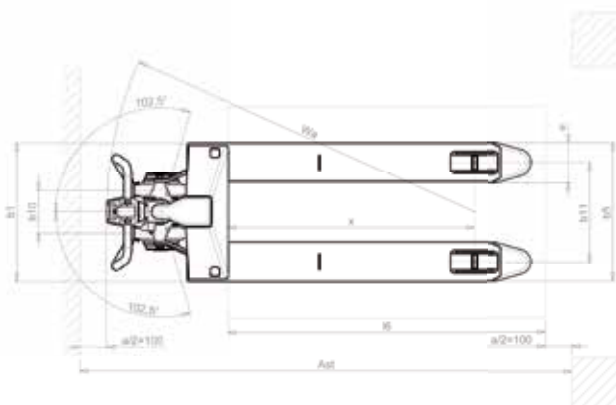
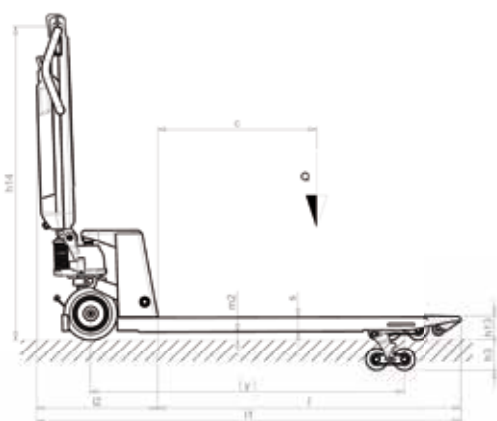



EGU 15 E **Li-ION** Electric pallet trucks

Capacity 1500 kg

Ideal for internal transport of palletised goods on even ground, covering short to medium distances.

The EGU 15 E is the new generation of electric pallet trucks. With its compact dimensions and new Lithium battery, it is an ideal alternative to the standard pallet truck and, with only 123 kg service weight the perfect driving device on a truck.

Supplied as standard with a replaceable battery the discharged battery can be exchanged with a fully charged battery within seconds, minimising the amount of disruption to the work cycle. Charging time for the battery is only 2.5 hours.

Features

- Maintenance-free rechargeable Lithium battery.
- Integrated battery management system controls all important parameters and performance of the lithium battery.
- Charging time of only 2.5 hours, intermediate charge is possible.
- Integrated PIN code panel with LCD display.
- Curtis-Controller and CAN-Bus technology.
- Infinitely variable driving speed.
- External battery charger for charging with a 230V plug socket.
- Battery charge indicator and operating hour counter.
- Entry rollers ensure smooth entry into bottom-boarded pallets.

Scope of delivery

- Maintenance free rechargeable Lithium battery 24 Volt/20 Ah (30 or 36 Ah as option)
- External charger

Li-ION battery

This battery offers much longer operational periods and overall lifetime with shorter charges.

- The Li-ION battery has a lifespan of up to 3000 charging cycles.
- Charging time of only 2.5 hours.
- Intermediate charge is possible without affecting the lifetime of the battery.
- No loss of power when the battery charge state drops.



Optional: replaceable battery with 20Ah, 30Ah or 36Ah



Fast battery change – with a single touch

Technical data EGU 15 E Li-ION

| Model | EGU 15 E <i>Li-ION</i> |
|--|------------------------|
| Art.-No. | N23315461 |
| Capacity, kg | 1500 |
| Tyre type ¹ | PUR/PUR |
| Steering rollers l x d, mm | 210 x 70 |
| Load rollers l x d, mm | 80 x 93 |
| Number of wheels/load rollers (x=driven) | 2 + 1x/4 |
| Stroke h3, mm | 115 |
| Load center c, mm | 600 |
| Fork height max., mm | 195 |
| Fork height lowered h13, mm | 85 |
| Height of control handle h14, mm | 1160 |
| Overall length l1, mm | 1530 |
| Overall width b1, mm | 540 |
| Fork dimensions s/e/l, mm | 47 x 160 x 1150 |
| Outside dimension of forks b5, mm | 540 |
| Aisle width pallet Ast, mm | 2000 |
| Turning circle radius Wa, mm | 1330 |
| Actuation | electric |
| Operation | pedestrian |
| Travel speed with/without load, km/h | 4.6/4.8 |
| Lifting speed with/without load, m/s | 0.020/0.025 |
| Lowering speed with/without load, m/s | 0.05/0.04 |
| Gradient with/without load, % | 5/10 |
| Drive motor rating, kW | 0.65 |
| Hoist motor rating, kW | 0.5 |
| Service brake | electric |
| Battery | Li-ION |
| Battery voltage, V/Ah | 24/20 |
| Weight with battery in kg | 123 |

¹PUR... Polyurethane

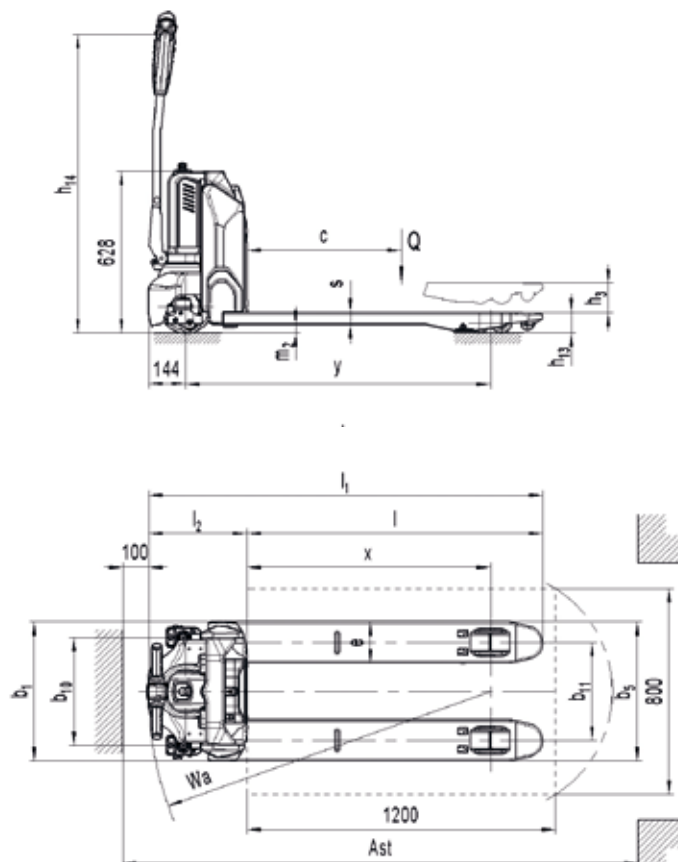



EGU PS 14 Electric pallet trucks

Capacity 1400 kg

Electrical drive, electrical lifting.

Ideal for the transportation of palletised goods within a warehouse environment.

Due to the extremely small turning circle it is also ideal for working on ramps or taking along on a lorry. The powerful motor allows fast operation.

The truck is available in three versions:

EGU PS 14 Basic

EGU PS 14 Plus and

EGU PS 14 **Li-ION**

Features

- Reduced dimensions: L2 only 410 mm.
- Creep speed button for pin-point work in confined spaces.
- Reliable impulse control for stepless regulation of driving speed.
- Integrated battery charger for charging on a 230V plug socket.
- Digital display for battery status

EGU PS 14 Basic

The unit is supplied with a DC traction motor and a tubular steel drawbar with integrated controls. The Basic version is the entry level model.

EGU PS 14 Plus

The Plus Version with the powerful Gel battery gives a plus in capacity and a longer battery life. The Plus also includes a maintenance-friendly AC traction motor with reduced power consumption and higher driving speed. The ergonomically designed multifunctional drawbar contains all operating and control functions, such as hour meter and charging indicator.

EGU PS 14 **Li-ION**

These versions offers much longer operational periods and overall lifetime of the battery with shorter charges.

- The Li-ION battery has a lifespan of up to 3000 charging cycles.
- Charging time of only 2.5 hours.
- Intermediate charge is possible without affecting the lifetime of the battery.
- No loss of power when the battery charge state drops.

Technical data EGU PS 14

| Model | EGU PS 14 Basic | EGU PS 14 Plus | EGU PS 14 <i>Li-ION</i> |
|--|---------------------|---------------------|-------------------------|
| Art.-No. | 192062096 | 192062097 | 192062098 |
| Capacity, kg | 1400 | 1400 | 1400 |
| Tyre type ¹ | VG/PUR | VG/PUR | VG/PUR |
| Steering rollers l x d, mm | 250 x 76 + 100 x 40 | 250 x 76 + 100 x 40 | 250 x 76 + 100 x 40 |
| Load rollers l x d, mm | 82 x 80 | 82 x 80 | 82 x 80 |
| Number of wheels/load rollers (x=driven) | 2 + 1x/2 | 2 + 1x/2 | 2 + 1x/2 |
| Wheelbase Y, mm | 1196 | 1196 | 1196 |
| Stroke h2, mm | 115 | 115 | 115 |
| Load center c, mm | 600 | 600 | 600 |
| Fork height max. h3, mm | 200 | 200 | 200 |
| Fork height lowered, mm | 85 | 85 | 85 |
| Height of control handle max., mm | 1230 | 1230 | 1230 |
| Overall length L, mm | 1560 | 1560 | 1560 |
| Length incl. apron L2, mm | 410 | 410 | 410 |
| Overall width B, mm | 720 | 720 | 720 |
| Fork dimensions s1/n/l, mm | 50 x 150 x 1150 | 50 x 150 x 1150 | 50 x 150 x 1150 |
| Outside dimension of forks m, mm | 525 | 525 | 525 |
| Aisle width pallet Ast, mm | 1810 | 1810 | 1810 |
| Turning circle radius Wa, mm | 1345 | 1345 | 1345 |
| Actuation | electric | electric | electric |
| Operation | pedestrian | pedestrian | pedestrian |
| Travel speed with/without load, km/h | 4.4/4.8 | 6.0/6.0 | 6.0/6.0 |
| Lifting speed with/without load, m/s | 0.03/0.04 | 0.03/0.04 | 0.03/0.04 |
| Lowering speed with/without load, m/s | 0.05/0.04 | 0.05/0.04 | 0.05/0.04 |
| Gradient with/without load, % | 5/10 | 5/10 | 5/10 |
| Drive motor rating, kW | 0.7 | 0.7 | 0.7 |
| Hoist motor rating, kW | 1.0 | 1.0 | 1.0 |
| Service brake | electric | electric | electric |
| Battery | starter | Gel | Li-ION |
| Battery voltage 20 h, in V/Ah | 24/70 | 24/65 | 24/50 |
| Weight with battery in kg | 227 | 256 | 212 |

¹VG... Solid rubber, PUR... Polyurethane

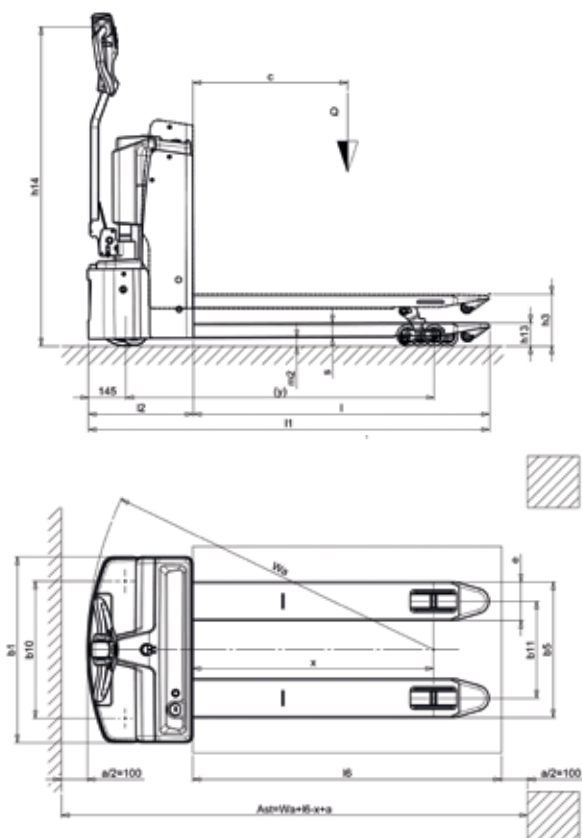

*Our top seller
with over half a million
units sold!*

Ergonomically designed control handle with rubber coating for better grip.

Infinitely variable lowering speed.

Reinforced construction for greater stability.

Fork entry rollers make easy entry into the wide side of Euro pallets.

Galvanized, maintenance-friendly, and extremely durable hydraulic unit with integral reservoir. The enclosed hydraulic system protects against damage.

5 different tyre combinations to suit all your needs.

HV 0516 Manual drive stacker with manual-hydraulic lift

Capacity 500 kg

Ideal for the occasional, internal application of stacking and transporting of palletised goods, loading and unloading of shelves and lorries.

Features

- Ergonomic safety control handle for one-hand operation of lifting, driving and lowering.
- Handlebars for easy operation.
- Lowering speed can be finely metered for sensitive lowering of the load.
- Single-acting hand pump with increased lift per handle stroke.
- Robust mast construction with hard chromium plated piston.
- Steering roller with brake for safe parking of the hand stacker.

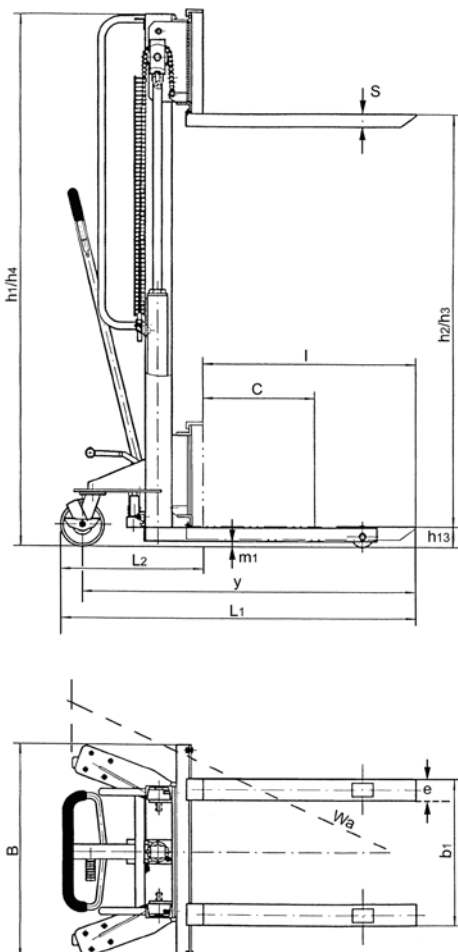

Technical data HV 0516

| Model | HV 0516 |
|--|----------|
| Art.-No. | 40005551 |
| Capacity, kg | 500 |
| Load center c, mm | 600 |
| Wheelbase y, mm | 1630 |
| Weight, kg | 160 |
| Tyre type ¹ | PA/PUR |
| Steering rollers, mm | 145 x 40 |
| Load rollers, mm | 80 x 35 |
| Number of wheels/load rollers | 2/2 |
| Height, mast retracted h1, mm | 2000 |
| Freelift h2, mm | 1520 |
| Stroke h3, mm | 1520 |
| Height, mast extended h4, mm | 2000 |
| Lifting height max. h3 + h13, mm | 1600 |
| Fork height lowered h13, mm | 90 |
| Overall length L1, mm | 1750 |
| Length incl. apron L2, mm | 480 |
| Overall width B, mm | 830 |
| Fork height s, mm | 50 |
| Fork width e, mm | 120 |
| Fork length l, mm | 1150 |
| Outside dimension of forks adjustable up to b1, mm | 270/810 |
| Ground clearance m1, mm | 25 |
| Turning circle radius Wa, mm | 1500 |
| Lift per one crank rotation with/without load, mm | 20/45 |

¹PA... Polyamide, PUR... Polyurethane



HV 1008 and HV 1016 Manual drive stacker

Capacity 1000 kg

Ideal for the occasional, internal application of stacking and transporting of palletised goods.

Features

- Ergonomic safety control handle for one-hand operation of lifting, driving and lowering.
- Easy handling due to forced steering rollers.
- Lowering speed can be finely metered for sensitive lowering of the load.
- Single-acting hand pump with increased lift per handle stroke.
- Quick-lift for loads up to 100 kg.
- Robust mast construction with hard chromium plated piston.
- Steering roller with brake for safe parking of the hand stacker.



Technical data HV 1008 and HV 1016

| Model | HV 1008 | HV 1016 |
|---|----------|----------|
| Art.-No. | 34518032 | 34518030 |
| Capacity, kg | 1000 | 1000 |
| Load center c, mm | 600 | 600 |
| Wheelbase y, mm | 1075 | 1075 |
| Weight, kg | 179 | 205 |
| Tyre type ¹ | PUR/PUR | PUR/PUR |
| Steering rollers, mm | 180 x 50 | 180 x 50 |
| Load rollers, mm | 80 x 55 | 80 x 55 |
| Number of wheels/load rollers | 2/2 | 2/2 |
| Height, mast retracted h1, mm | 1300 | 1965 |
| Freelift h2, mm | 810 | 1510 |
| Stroke h3, mm | 810 | 1510 |
| Height, mast extended h4, mm | 1300 | 1965 |
| Lifting height max. h3 + h13, mm | 900 | 1600 |
| Fork height lowered h13, mm | 90 | 90 |
| Overall length L1, mm | 1675 | 1675 |
| Length incl. apron L2, mm | 552 | 552 |
| Overall width B, mm | 765 | 765 |
| Fork height s, mm | 60 | 60 |
| Fork width e, mm | 60 | 60 |
| Fork length l, mm | 1122 | 1122 |
| Outside dimension of forks b1, mm | 570 | 570 |
| Ground clearance m1, mm | 25 | 25 |
| Aisle width pallet Ast, mm | 1875 | 1875 |
| Turning circle radius Wa, mm | 1445 | 1445 |
| Lift per one crank rotation with/without load, mm | 17/50 | 17/50 |

¹PUR... Polyurethane

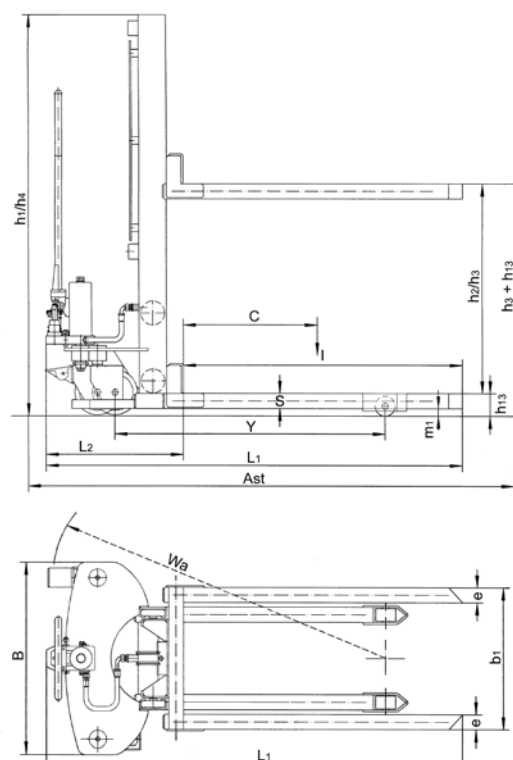

EHH PSE Manual drive stacker with electric-hydraulic lift

Capacity 1000 kg,
fork height max. 3000 mm

Suitable for occasional applications of stacking and transporting palletised loads, also for use in confined areas and for short distances.

Features

- Good maneuverability and easy handling due to positive steering of the unit.
- Compact electric-hydraulic lifting device and overload protection.
- Finely metered lowering of load through pressure relief valve and adjustable lowering valve.
- Retention by parking brake.
- Robust frame with two load and two steer rollers.
- The maintenance free battery can be charged at any 230V plug socket.

Scope of delivery

- Battery and battery charger included.



Technical data EHH PSE

| Model | EHH PSE 1016 | EHH PSE 1025 | EHH PSE 1030 |
|---------------------------------------|-----------------------|-----------------------|-----------------------|
| Art.-No. | 40050660 | 40050661 | 40050662 |
| Capacity (up to 2.5 m lift), kg | 1000 | 1000 | 1000 |
| Load center c, mm | 600 | 600 | 600 |
| Wheelbase y, mm | 1160 | 1160 | 1160 |
| Weight (with battery), kg | 395 | 455 | 475 |
| Tyre type ¹ | PA/PUR | PA/PUR | PA/PUR |
| Steering rollers, mm | 180 x 50 | 180 x 50 | 180 x 50 |
| Load rollers, mm | 74 x 70 | 74 x 70 | 74 x 70 |
| Number of wheels/load rollers | 2/4 | 2/4 | 2/4 |
| Height, mast retracted h1, mm | 1980 | 1830 | 2080 |
| Freelift h2, mm | 1415 | - | - |
| Stroke h3, mm | 1515 | 2415 | 2915 |
| Height, mast extended h4, mm | 2030 | 3020 | 3515 |
| Lifting height max. h3 + h13, mm | 1600 | 2500 | 3000 |
| Fork height lowered h13, mm | 85 | 85 | 85 |
| Overall length L1, mm | 1720 | 1720 | 1720 |
| Length incl. apron L2, mm | 555 | 555 | 555 |
| Overall width b1/b2, mm | 765 | 765 | 765 |
| Fork height s, mm | 60 | 60 | 60 |
| Fork width e, mm | 180 | 180 | 180 |
| Fork length l, mm | 1100 | 1100 | 1100 |
| Outside dimension of forks b5, mm | 570 | 570 | 570 |
| Ground clearance m2, mm | 25 | 25 | 25 |
| Aisle width pallet Ast, mm | 2145 | 2145 | 2145 |
| Turning circle radius Wa, mm | 1280 | 1280 | 1280 |
| Lifting speed with/without load, m/s | 0.08/0.13 | 0.08/0.13 | 0.08/0.13 |
| Lowering speed with/without load, m/s | 0.42/0.19 | 0.42/0.19 | 0.42/0.19 |
| Hoist motor rating, kW | 1.5 | 1.5 | 1.5 |
| Battery according to DIN 43531 | semi traction battery | semi traction battery | semi traction battery |
| Battery charger, V/A | 12/20A | 12/20A | 12/20A |
| Battery voltage, capacity, V/Ah | 12/130 | 12/130 | 12/130 |

¹PA... Polyamide, PUR... Polyurethane

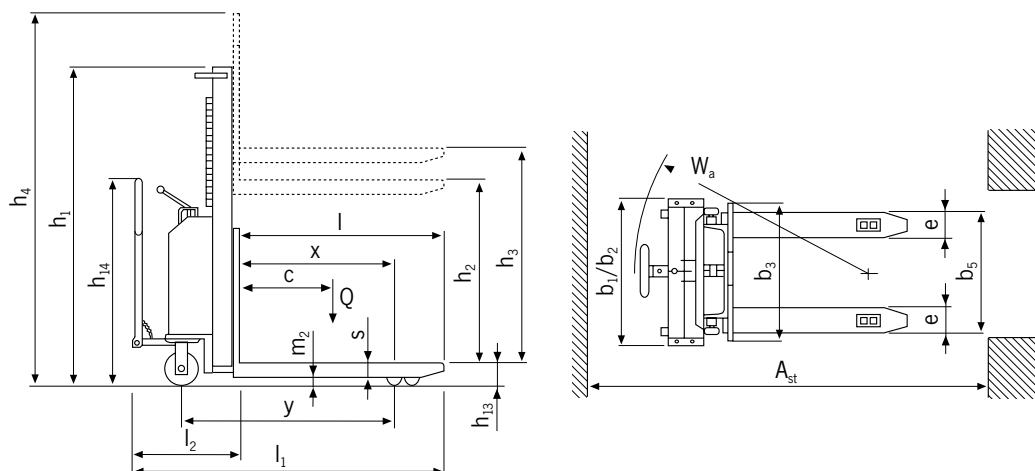

EHH PS **Manual drive stacker** **with electric-hydraulic lift**

Capacity 1000 - 1200 kg,
fork height max. 3500 mm

Suitable for occasional to medium applications of stacking and transporting palletised loads, also in confined areas.

Features

- Easy to operate via tie-rod guides to both steer wheels.
- Compact electric-hydraulic lifting device and overload protection.
- Finely metered lowering of load through pressure relief valve and adjustable lowering valve.
- Mast welded from precision profiles, fork carriage with maintenance free guide rollers.
- Retention by parking brake.
- Robust frame with two load and two steer rollers.

Scope of delivery

- Battery and battery charger included.



Technical data EHH PS

| Model | EHH PS 1009 | EHH PS 1016 | EHH PS 1225 | EHH PS 1229 | EHH PS 1235 |
|---------------------------------------|-------------|-------------|-------------|-------------|-------------|
| Art.-No. | 40046051 | 40044422 | 40044424 | 40044425 | 40044426 |
| Capacity (up to 2.5 m lift), kg | 1000 | 1000 | 1200 | 1200 | 1200 |
| Load center c, mm | 600 | 600 | 600 | 600 | 600 |
| Wheelbase y, mm | 965 | 965 | 1155 | 1155 | 1155 |
| Weight (with battery), kg | 296 | 311 | 433 | 449 | 496 |
| Tyre type ¹ | VG/PA | VG/PA | PUR/PA | PUR/PA | PUR/PA |
| Steering rollers, mm | 200 x 50 | 200 x 50 | 200 x 50 | 200 x 50 | 200 x 50 |
| Load rollers, mm | 82 x 70 | 82 x 70 | 82 x 70 | 82 x 70 | 82 x 70 |
| Number of wheels/load rollers | 2/2 | 2/2 | 2/2 | 2/2 | 2/2 |
| Height, mast retracted h1, mm | 1300 | 1970 | 1780 | 1980 | 2250 |
| Freelift h2, mm | 810 | 1510 | - | - | 80 |
| Stroke h3, mm | 810 | 1510 | 2410 | 2810 | 3410 |
| Height, mast extended h4, mm | 1300 | 1970 | 2985 | 3385 | 3915 |
| Lifting height max. h3 + h13, mm | 900 | 1600 | 2500 | 2900 | 3500 |
| Fork height lowered h13, mm | 90 | 90 | 90 | 90 | 90 |
| Overall length L1, mm | 1750 | 1750 | 1850 | 1850 | 1850 |
| Length incl. apron L2, mm | 600 | 600 | 700 | 700 | 700 |
| Overall width b1/b2, mm | 750 | 750 | 850 | 850 | 850 |
| Fork height s, mm | 70 | 70 | 70 | 70 | 70 |
| Fork width e, mm | 150 | 150 | 150 | 150 | 150 |
| Fork length l, mm | 1150 | 1150 | 1150 | 1150 | 1150 |
| Outside dimension of forks b5, mm | 560 | 560 | 560 | 560 | 560 |
| Ground clearance m2, mm | 20 | 20 | 20 | 20 | 20 |
| Aisle width pallet Ast, mm | 2210 | 2210 | 2375 | 2375 | 2375 |
| Turning circle radius Wa, mm | 1440 | 1440 | 1760 | 1760 | 1760 |
| Lifting speed with/without load, m/s | 0.09/0.12 | 0.09/0.12 | 0.08/0.12 | 0.08/0.12 | 0.08/0.12 |
| Lowering speed with/without load, m/s | 0.4/0.1 | 0.4/0.1 | 0.4/0.1 | 0.4/0.1 | 0.4/0.1 |
| Hoist motor rating, kW | 1.6 | 1.6 | 2.2 | 2.2 | 2.2 |
| Battery according to DIN 43531 | starter | starter | starter | starter | starter |
| Battery charger, V/A | 12/10 | 12/10 | 12/10 | 12/10 | 12/10 |
| Battery voltage, capacity, V/Ah | 12/74 | 12/74 | 24/74 | 24/74 | 24/74 |

¹PA... Polyamide, PUR... Polyurethane, VG... Solid rubber

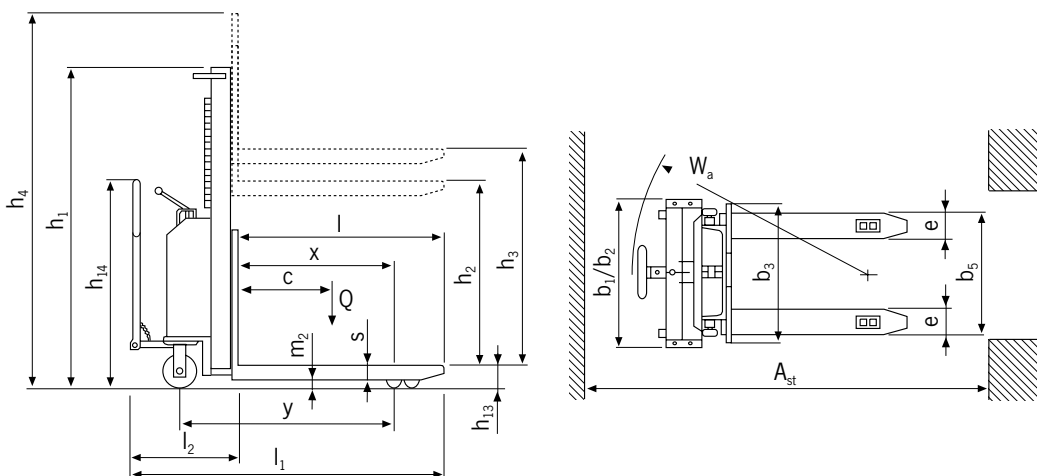

EGV PSL 1016 II Electric pedestrian stacker

Capacity 1000 kg,
fork height max. 1600 mm

The EGV PSL 1016 II is the ideal solution for indoor transportation and of palletised goods within a warehouse environment for short haul and medium work load applications.

Features

- The slim single mast and the laterally, ergonomic tiller ensure a free view onto the goods as in front of the stacker.
- The fork thickness of 60 mm enables an easier entrance inside pallets, while working in elevation.
- Easy maintenance – the convenient access opening at the bottom of the forklift allows an immediate disassembly of motor wheel without lifting the machine.
- The reduced overall width of 794 mm improves the handling of goods in narrow spaces and corridors.
- Ultra-slow drive function enables exact driving in very tight spaces.
- Gel battery as standard.

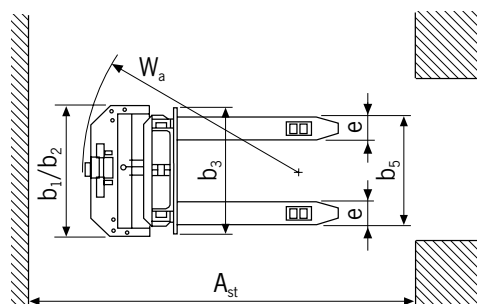
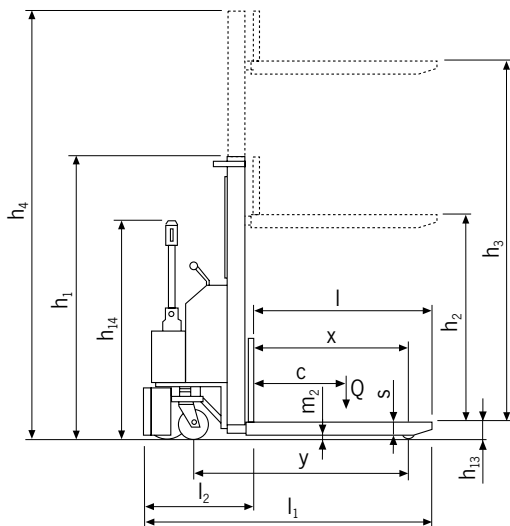

Technical data EGV PSL 1016 II

| Model | EGV PSL 1016 II |
|---------------------------------------|---------------------|
| Art.-No. | 192021784 |
| Capacity (up to 2.5m lift), kg | 1000 |
| Steering rollers, mm | 186 x 50 + 125 x 45 |
| Load rollers, mm | 82 x 70 |
| Height, mast retracted h1, mm | 1970 |
| Freelift h2, mm | 1510 |
| Stroke, mm | 1510 |
| Height, mast extended h4, mm | 1970 |
| Fork height max. h3, mm | 1600 |
| Fork height lowered h13, mm | 90 |
| Overall length L1, mm | 1675 |
| Overall width b1/b2, mm | 794 |
| Fork height s, mm | 60 |
| Fork width e, mm | 150 |
| Fork length l, mm | 1153 |
| Outside dimension of forks b5, mm | 560 |
| Travel speed with/without load, km/h | 3.7/4.3 |
| Lifting speed with/without load, m/s | 0.11/0.18 |
| Lowering speed with/without load, m/s | 0.18/0.18 |
| Drive motor rating, kW | 0.35 |
| Hoist motor rating, kW | 2.2 |
| Battery | Gel |
| Battery charger, V/A | 24/12 |
| Battery voltage, V/Ah | 24/50 |

EGV PSL II

Electric pedestrian stacker

Capacity 1200 kg,
fork height max. 3500 mm

The revised EGV PSL II is the ideal solution for indoor transportation and of palletized goods within a warehouse environment for short haul and medium work load applications.

Features

- The wide mast and the laterally, ergonomic tiller ensure a free view onto the goods as in front of the stacker.
- All functions are comfortably controlled from the tiller head.
- The reduced overall width of 800 mm improves the handling of goods in narrow spaces and corridors.
- Ultra-slow drive function enables exact driving in very tight spaces.
- Easy maintenance – the convenient access opening at the bottom of the forklift allows an immediate disassembly of motor wheel without lifting the machine.
- Improved drive- and lifting speed.
- The spiral charging cable which can be stored in the chassis enables easy charging at every socket.

Options

Plus version

- Maintenance-free Gel batteries with increased working hours and a doubled lifetime expectancy.
- Finely metered lifting and lowering due to a soft valve control.
- Faster lowering speed

Freelift version

- The EGV PSL 1229 II plus Freelift has a fullfreelift. It can lift the forks up to 1500 mm without increasing the base mast height.

Scope of delivery

- Battery and battery charger included.



Technical data EGV PSL II

| Model | EGV PSL 1225 II | EGV PSL 1229 II | EGV PSL 1235 II |
|---|---------------------|---------------------|---------------------|
| Art.-No. | 192033602 | 192033615 | 192033616 |
| Actuation | electric | electric | electric |
| Operation | pedestrian | pedestrian | pedestrian |
| Capacity (up to 2.5 m lift), kg | 1200 | 1200 | 1200 |
| Load center c, mm | 600 | 600 | 600 |
| Wheelbase y, mm | 1234 | 1234 | 1234 |
| Weight (with battery), kg | 568 | 583 | 616 |
| Tyre type ¹ | PUR/VG + PUR | PUR/VG + PUR | PUR/VG + PUR |
| Steering rollers, mm | 250 x 76 + 100 x 38 | 250 x 76 + 100 x 38 | 250 x 76 + 100 x 39 |
| Load rollers, mm | 82 x 70 | 82 x 70 | 82 x 70 |
| Number of wheels/load rollers (x=driven) | 1x + 1/2 | 1x + 1/2 | 1x + 1/2 |
| Height, mast retracted h ₁ , mm | 1787 | 1987 | 2250 |
| Freelift h ₂ , mm | - | - | 80 |
| Stroke, mm | 2410 | 2810 | 3410 |
| Height, mast extended h ₄ , mm | 2992 | 3392 | 3916 |
| Fork height max. h ₃ , mm | 2500 | 2900 | 3500 |
| Height of control handle min./max. h ₁₄ , mm | 915/1310 | 915/1310 | 915/1310 |
| Fork height lowered h ₁₃ , mm | 90 | 90 | 90 |
| Overall length L ₁ , mm | 1760 | 1760 | 1760 |
| Length incl. apron L ₂ , mm | 609 | 609 | 609 |
| Overall width b ₁ /b ₂ , mm | 800 | 800 | 800 |
| Fork height s, mm | 70 | 70 | 70 |
| Fork width e, mm | 150 | 150 | 150 |
| Fork length l, mm | 1150 | 1150 | 1150 |
| Outside dimension of forks b ₅ , mm | 560 | 560 | 560 |
| Ground clearance m ₂ , mm | 20 | 20 | 20 |
| Aisle width pallet A _{st} , mm | 2210 | 2210 | 2210 |
| Turning circle radius W _a , mm | 1430 | 1430 | 1430 |
| Travel speed with/without load, km/h | 4.7/5.2 | 4.7/5.2 | 4.7/5.2 |
| Lifting speed with/without load, m/s | 0.11/0.19 | 0.11/0.19 | 0.11/0.19 |
| Lowering speed with/without load, m/s | 0.12/0.15 | 0.12/0.15 | 0.12/0.15 |
| Gradient with/without load, % | 5/10 | 5/10 | 5/10 |
| Service brake | electric | electric | electric |
| Drive motor rating, kW | 0.7 | 0.7 | 0.7 |
| Hoist motor rating, kW | 2.2 | 2.2 | 2.2 |
| Battery | starter | starter | starter |
| Battery charger, V/A | 24/13 | 24/13 | 24/13 |
| Battery voltage, V/Ah | 24/85 | 24/85 | 24/85 |

¹PUR... Polyurethane, VG... Solid rubber

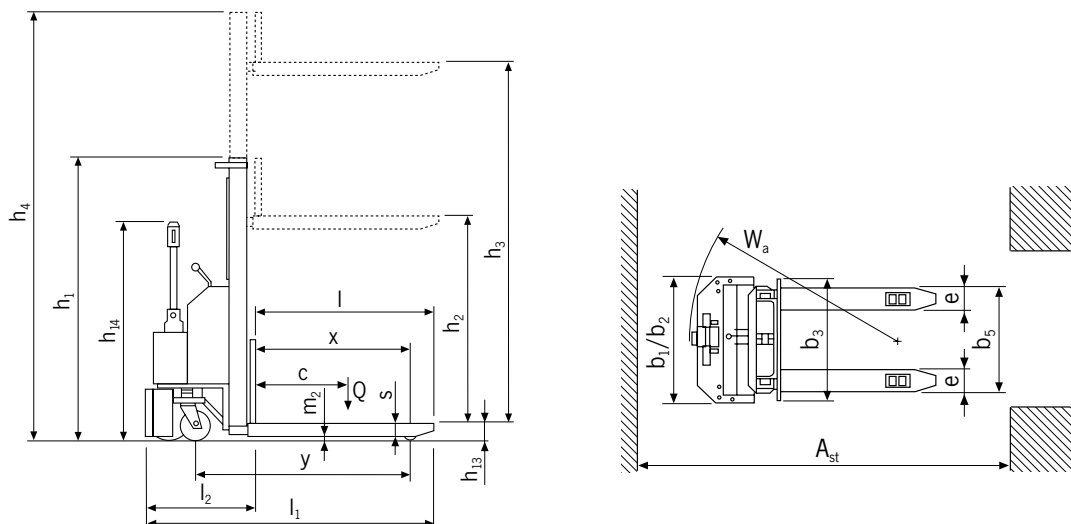

Technical data EGV PSL II plus and EGV PSL II plus Freelift

| Model | EGV PSL 1225 II plus | EGV PSL 1229 II plus | EGV PSL 1235 II plus | EGV PSL 1229 II plus Freelift |
|--|----------------------|----------------------|----------------------|-------------------------------|
| Art.-No. | 192033617 | 192033618 | 192033620 | 192033621 |
| Actuation | electric | electric | electric | electric |
| Operation | pedestrian | pedestrian | pedestrian | pedestrian |
| Capacity (up to 2.5 m lift), kg | 1200 | 1200 | 1200 | 1200 |
| Load center c, mm | 600 | 600 | 600 | 600 |
| Wheelbase y, mm | 1234 | 1234 | 1234 | 1234 |
| Weight (with battery), kg | 648 | 663 | 696 | 693 |
| Tyre type ¹ | PUR/VG + PUR | PUR/VG + PUR | PUR/VG + PUR | PUR/VG + PUR |
| Steering rollers, mm | 250 x 76 + 100 x 40 | 250 x 76 + 100 x 41 | 250 x 76 + 100 x 42 | 250 x 76 + 100 x 43 |
| Load rollers, mm | 82 x 70 | 82 x 70 | 82 x 70 | 82 x 70 |
| Number of wheels/load rollers (x=driven) | 1x + 1/2 | 1x + 1/2 | 1x + 1/2 | 1x + 1/2 |
| Height, mast retracted h1, mm | 1787 | 1987 | 2250 | 1965 |
| Freelift h2, mm | 0 | 0 | 80 | 1402 |
| Stroke, mm | 2410 | 2810 | 3410 | 2810 |
| Height, mast extended h4, mm | 2992 | 3392 | 3916 | 3372 |
| Fork height max. h3, mm | 2500 | 2900 | 3500 | 2900 |
| Height of control handle min./max. h14, mm | 915/1310 | 915/1310 | 915/1310 | 915/1310 |
| Fork height lowered h13, mm | 90 | 90 | 90 | 90 |
| Overall length L1, mm | 1760 | 1760 | 1760 | 1760 |
| Length incl. apron L2, mm | 609 | 609 | 609 | 609 |
| Overall width b1/b2, mm | 800 | 800 | 800 | 800 |
| Fork height s, mm | 70 | 70 | 70 | 70 |
| Fork width e, mm | 150 | 150 | 150 | 150 |
| Fork length l, mm | 1150 | 1150 | 1150 | 1150 |
| Outside dimension of forks b5, mm | 560 | 560 | 560 | 560 |
| Ground clearance m2, mm | 20 | 20 | 20 | 20 |
| Aisle width pallet Ast, mm | 2210 | 2210 | 2210 | 2210 |
| Turning circle radius Wa, mm | 1430 | 1430 | 1430 | 1430 |
| Travel speed with/without load, km/h | 4.7/5.2 | 4.7/5.2 | 4.7/5.2 | 4.7/5.2 |
| Lifting speed with/without load, m/s | 0.11/0.19 | 0.11/0.19 | 0.11/0.19 | 0.11/0.19 |
| Lowering speed with/without load, m/s | 0.19/0.19 | 0.19/0.19 | 0.19/0.19 | 0.16/0.14 |
| Gradient with/without load, % | 5/10 | 5/10 | 5/10 | 5/10 |
| Service brake | electric | electric | electric | electric |
| Drive motor rating, kW | 0.7 | 0.7 | 0.7 | 0.7 |
| Hoist motor rating, kW | 2.2 | 2.2 | 2.2 | 2.2 |
| Battery | Gel | Gel | Gel | Gel |
| Battery charger, V/A | 24/13 | 24/13 | 24/13 | 24/13 |
| Battery voltage, V/Ah | 24/105 | 24/105 | 24/105 | 24/105 |

¹PUR...Polyurethane, VG...Solid rubber

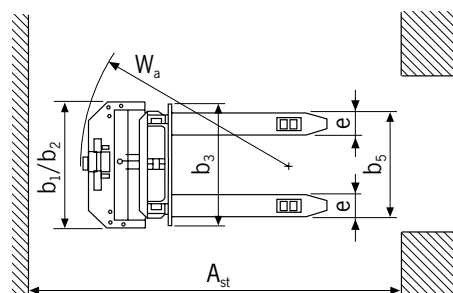
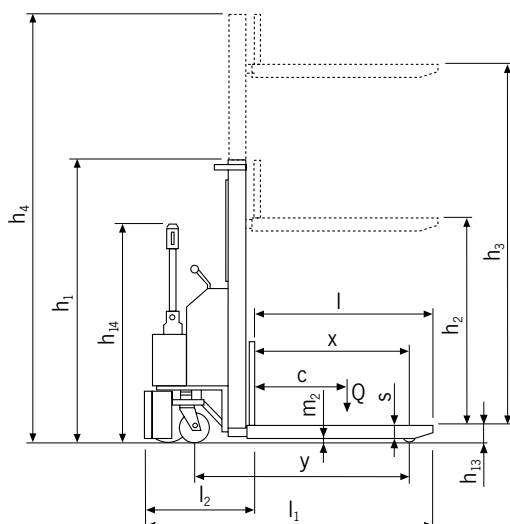

EGV PSH II Electric pedestrian stacker

Capacity 1200 - 1600 kg,
fork height max. 5000 mm

The revised edition of the model range EGV PSH II is the professional solution for indoor transportation and stacking of palletised loads over longer distances and higher capacity utilization.

Features

- Multifunctional control handle with integrated drive switches and lifting and lowering functions directly on the control handle.
- Proportionally controllable lifting and lowering functions for better positioning of the loads.
- Compact overall dimensions, only 800 mm wide allows operations in narrow corridors.
- Ultra-slow drive function enables exact driving in very tight spaces.
- Drive and lifting speeds have been increased for this revised model.

Options

- Drivers platform
- Freelift



INFO

Battery and battery charger are to be ordered separately.

Technical data EGV PSH 12 II

| Model | EGV PSH 12-16 II | EGV PSH 12-25 II | EGV PSH 12-29 II | EGV PSH 12-35 II |
|--|----------------------|----------------------|----------------------|----------------------|
| Art.-No. | N25412161 | N25412251 | N25412291 | N25412351 |
| Actuation | electric | electric | electric | electric |
| Operation | pedestrian | pedestrian | pedestrian | pedestrian |
| Capacity (up to 2.5 m lift), kg | 1200 | 1200 | 1200 | 1200 |
| Load center c, mm | 600 | 600 | 600 | 600 |
| Wheelbase y, mm | 1307 | 1307 | 1307 | 1307 |
| Weight (with battery 180 Ah), kg | 841 | 900 | 915 | 937 |
| Tyre type ¹ | PUR/VG + PUR | PUR/VG + PUR | PUR/VG + PUR | PUR/VG + PUR |
| Steering rollers, mm | 250 x 101 + 100 x 38 | 250 x 101 + 100 x 38 | 250 x 101 + 100 x 38 | 250 x 101 + 100 x 38 |
| Load rollers, mm | 82 x 70 | 82 x 70 | 82 x 70 | 82 x 70 |
| Number of wheels/load rollers (x=driven) | 1x + 2/4 | 1x + 2/4 | 1x + 2/4 | 1x + 2/4 |
| Height, mast retracted h1, mm | 1965 | 1785 | 1987 | 2265 |
| Freelift h2, mm | 1510 | - | - | 80 |
| Stroke, mm | 1510 | 2410 | 2810 | 3410 |
| Height, mast extended h4, mm | 1965 | 2990 | 3392 | 3970 |
| Fork height max. h3, mm | 1600 | 2500 | 2900 | 3500 |
| Height of control handle max. h14, mm | 1390 | 1390 | 1390 | 1390 |
| Fork height lowered h13, mm | 90 | 90 | 90 | 90 |
| Overall length L1, mm | 1920 | 1920 | 1920 | 1920 |
| Length incl. apron L2, mm | 770 | 770 | 770 | 770 |
| Overall width b1/b2, mm | 800 | 800 | 800 | 800 |
| Fork height s, mm | 70 | 70 | 70 | 70 |
| Fork width e, mm | 150 | 150 | 150 | 150 |
| Fork length l, mm | 1150 | 1150 | 1150 | 1150 |
| Outside dimension of forks b5, mm | 560 | 560 | 560 | 560 |
| Ground clearance, mm | 20 | 20 | 20 | 20 |
| Aisle width pallet Ast, mm | 2169 | 2169 | 2169 | 2169 |
| Turning circle radius Wa, mm | 1550 | 1550 | 1550 | 1550 |
| Travel speed with/without load, km/h | 6/6 | 6/6 | 6/6 | 6/6 |
| Lifting speed with/without load, m/s | 0.12/0.17 | 0.12/0.17 | 0.12/0.17 | 0.12/0.17 |
| Lowering speed with/without load, m/s | 0.22/0.12 | 0.22/0.12 | 0.22/0.12 | 0.22/0.12 |
| Gradient with/without load, % | 5/10 | 5/10 | 5/10 | 5/10 |
| Service brake | electric | electric | electric | electric |
| Drive motor rating, kW | 1.2 | 1.2 | 1.2 | 1.2 |
| Hoist motor rating, kW | 3.2 | 3.2 | 3.2 | 3.2 |
| Battery ² | PzS | PzS | PzS | PzS |
| Battery voltage, V/Ah | 24/225-300 | 24/225-300 | 24/225-300 | 24/225-300 |
| Battery weight, kg | 270 | 270 | 270 | 270 |
| Type of control | impulse | impulse | impulse | impulse |

¹ PUR... Polyurethane, VG... Solid rubber

² PzS... Traction battery

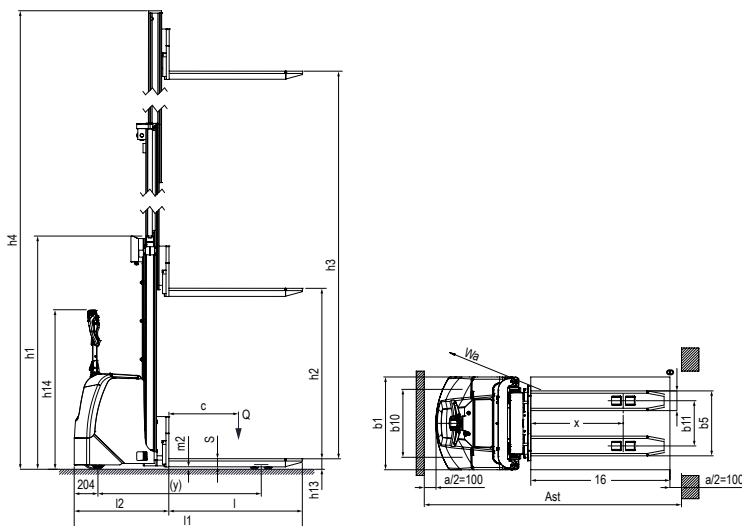

Technical data EGV PSH 14 II

| Model | EGV PSH 14-45T II | EGV PSH 14-45TF II | EGV PSH 14-50T II |
|--|----------------------|----------------------|----------------------|
| Art.-No. | N25414453 | N25414455 | N25414503 |
| Actuation | electric | electric | electric |
| Operation | pedestrian | pedestrian | pedestrian |
| Capacity (up to 2.5 m lift), kg | 1400 | 1400 | 1400 |
| Load center c, mm | 600 | 600 | 600 |
| Wheelbase y, mm | 1370 | 1370 | 1370 |
| Weight (with battery 180 Ah), kg | 1190 | 1223 | 1229 |
| Tyre type ¹ | PUR/VG + PUR | PUR/VG + PUR | PUR/VG + PUR |
| Steering rollers, mm | 250 x 101 + 100 x 38 | 250 x 101 + 100 x 38 | 250 x 101 + 100 x 38 |
| Load rollers, mm | 82 x 70 | 82 x 70 | 82 x 70 |
| Number of wheels/load rollers (x=driven) | 1x + 2/4 | 1x + 2/4 | 1x + 2/4 |
| Height, mast retracted h1, mm | 2080 | 2089 | 2285 |
| Freelift h2, mm | - | 1470 | - |
| Stroke, mm | 4410 | 4410 | 5025 |
| Height, mast extended h4, mm | 5020 | 5029 | 5635 |
| Fork height max. h3, mm | 4500 | 4500 | 5115 |
| Height of control handle max. h14, mm | 1390 | 1390 | 1390 |
| Fork height lowered h13, mm | 90 | 90 | 90 |
| Overall length L1, mm | 1966 | 1966 | 1966 |
| Length incl. apron L2 | 816 | 816 | 816 |
| Overall width b1/b2, mm | 800 | 800 | 800 |
| Fork height s, mm | 70 | 70 | 70 |
| Fork width e, mm | 170 | 170 | 170 |
| Fork length l, mm | 1150 | 1150 | 1150 |
| Outside dimension of forks b5, mm | 560 | 560 | 560 |
| Ground clearance, mm | 20 | 20 | 20 |
| Aisle width pallet Ast, mm | 2389 | 2389 | 2389 |
| Turning circle radius Wa, mm | 1613 | 1613 | 1613 |
| Travel speed with/without load, km/h | 6/6 | 6/6 | 6/6 |
| Lifting speed with/without load, m/s | 0.14/0.28 | 0.14/0.28 | 0.14/0.28 |
| Lowering speed with/without load, m/s | 0.34/0.40 | 0.34/0.40 | 0.34/0.40 |
| Gradient with/without load, % | 5/10 | 5/10 | 5/10 |
| Service brake | electric | electric | electric |
| Drive motor rating, kW | 1.2 | 1.2 | 1.2 |
| Hoist motor rating, kW | 3.2 | 3.2 | 3.2 |
| Battery ² | PzS | PzS | PzS |
| Battery voltage, V/Ah | 24/300 ³ | 24/300 ³ | 24/300 ³ |
| Battery weight, kg | 270 | 270 | 270 |
| Type of control | impulse | impulse | impulse |

¹PUR... Polyurethane, VG... Solid rubber

²PzS... Traction battery

³Unit only supplied with 300Ah battery

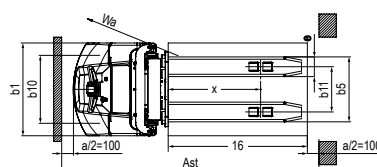
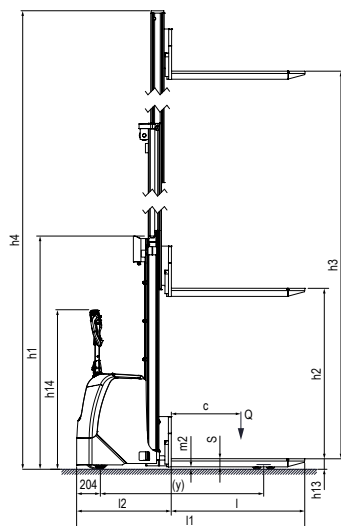

Technical data EGV PSH 16 II

| Model | EGV PSH 16-16 II | EGV PSH 16-25 II | EGV PSH 16-29 II | EGV PSH 16-35 II |
|--|----------------------|----------------------|----------------------|----------------------|
| Art.-No. | N25416161 | N25416251 | N25416291 | N25416351 |
| Actuation | electric | electric | electric | electric |
| Operation | pedestrian | pedestrian | pedestrian | pedestrian |
| Capacity (up to 2.5 m lift), kg | 1600 | 1600 | 1600 | 1600 |
| Load center c, mm | 600 | 600 | 600 | 600 |
| Wheelbase y, mm | 1370 | 1370 | 1370 | 1370 |
| Weight (with battery 180 Ah), kg | 920 | 1025 | 1050 | 1090 |
| Tyre type ¹ | PUR/VG + PUR | PUR/VG + PUR | PUR/VG + PUR | PUR/VG + PUR |
| Steering rollers, mm | 250 x 101 + 100 x 38 | 250 x 101 + 100 x 38 | 250 x 101 + 100 x 38 | 250 x 101 + 100 x 38 |
| Load rollers, mm | 82 x 70 | 82 x 70 | 82 x 70 | 82 x 70 |
| Number of wheels/load rollers (x=driven) | 1x + 2/4 | 1x + 2/4 | 1x + 2/4 | 1x + 2/4 |
| Height, mast retracted h1, mm | 1965 | 1765 | 1965 | 2265 |
| Freelift h2, mm | 1510 | - | - | - |
| Stroke, mm | 1510 | 2410 | 2810 | 3410 |
| Height, mast extended h4, mm | 1965 | 2970 | 3370 | 3970 |
| Fork height max. h3, mm | 1600 | 2500 | 2900 | 3500 |
| Height of control handle max. h14, mm | 1390 | 1390 | 1390 | 1390 |
| Fork height lowered h13, mm | 90 | 90 | 90 | 90 |
| Overall length L1, mm | 1944 | 1944 | 1944 | 1944 |
| Length incl. apron L2, mm | 795 | 795 | 795 | 795 |
| Overall width b1/b2, mm | 800 | 800 | 800 | 800 |
| Fork height s, mm | 70 | 70 | 70 | 70 |
| Fork width e, mm | 170 | 170 | 170 | 170 |
| Fork length l, mm | 1150 | 1150 | 1150 | 1150 |
| Outside dimension of forks b5, mm | 560 | 560 | 560 | 560 |
| Ground clearance, mm | 20 | 20 | 20 | 20 |
| Aisle width pallet Ast, mm | 2195 | 2195 | 2195 | 2195 |
| Turning circle radius Wa, mm | 1613 | 1613 | 1613 | 1613 |
| Travel speed with/without load, km/h | 6/6 | 6/6 | 6/6 | 6/6 |
| Lifting speed with/without load, m/s | 0.13/0.25 | 0.13/0.25 | 0.13/0.25 | 0.13/0.25 |
| Lowering speed with/without load, m/s | 0.31/0.38 | 0.31/0.38 | 0.31/0.38 | 0.31/0.38 |
| Gradient with/without load, % | 5/10 | 5/10 | 5/10 | 5/10 |
| Service brake | electric | electric | electric | electric |
| Drive motor rating, kW | 1.2 | 1.2 | 1.2 | 1.2 |
| Hoist motor rating, kW | 3.2 | 3.2 | 3.2 | 3.2 |
| Battery ² | PzS | PzS | PzS | PzS |
| Battery voltage, V/Ah | 24/225-300 | 24/225-300 | 24/225-300 | 24/225-300 |
| Battery weight, kg | 270 | 270 | 270 | 270 |
| Type of control | impulse | impulse | impulse | impulse |

¹ PUR... Polyurethane, VG... Solid rubber

² PzS... Traction battery

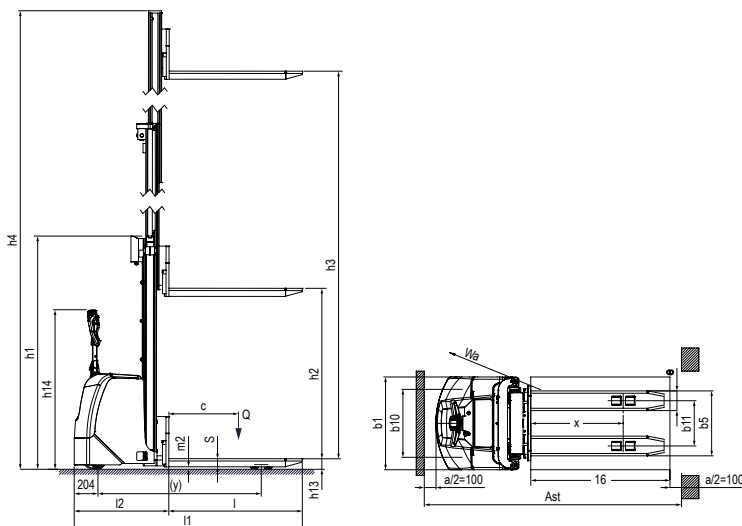

*The Hand pallet trucks
of the new generation of batteries
you will find
on pages 288-293*



HU 12-115 TP **Li-ION**



EGU 15 E **Li-ION**



EGU PS 14 **Li-ION**

Li-ION battery

This battery offers much longer operational periods and overall lifetime of the battery with shorter charges.

- The Li-ION battery has a lifespan of up to 3000 charging cycles.
- Charging time of only 2.5 hours.
- Intermediate charge is possible without affecting the lifetime of the battery.
- No loss of power when the battery charge state drops.

PRAKTIKUS HP Platformlift, mobile

Capacity 400 kg,
 platform height max. 1200 mm

For the occasional, internal application of lifting and transporting of goods.

Features

- Easy lifting by tiltable foot pedal.
- Lowering speed can be finely metered for sensitive lowering of the load.
- Ergonomic handlebar for easy operation.
- Steering roller with brake for safe parking of the hand stacker.
- Robust construction with chrome plated chassis, hard chromium plated piston and pressure relief valve.
- Covered chain deflection for increased safety.



Technical data PRAKTIKUS HP

| Model | HP 0412 |
|--|----------|
| Art.-No. | 40008779 |
| Capacity, kg | 400 |
| Platform height max. $h_3 + h_{13}$, mm | 1200 |
| Platform height min. h_{13} , mm | 200 |
| Freelift h_2 , mm | 1000 |
| Stroke h_3 , mm | 1000 |
| Lifting height per pump stroke, mm | 23 |
| Overall height h_1 , mm | 1310 |
| Overall length L_1 , mm | 1037 |
| Overall width b_1 , mm | 590 |
| Platform length P_1 , mm | 650 |
| Platform width P_2 , mm | 550 |
| Tyre type ¹ | VG/VG |
| Steering rollers, mm | 150 x 45 |
| Load rollers, mm | 150 x 45 |
| Number of wheels/load rollers | 2/2 |
| Ground clearance m_1 , mm | 50 |
| Wheelbase y , mm | 785 |
| Weight, kg | 71 |

¹ VG... Solid rubber

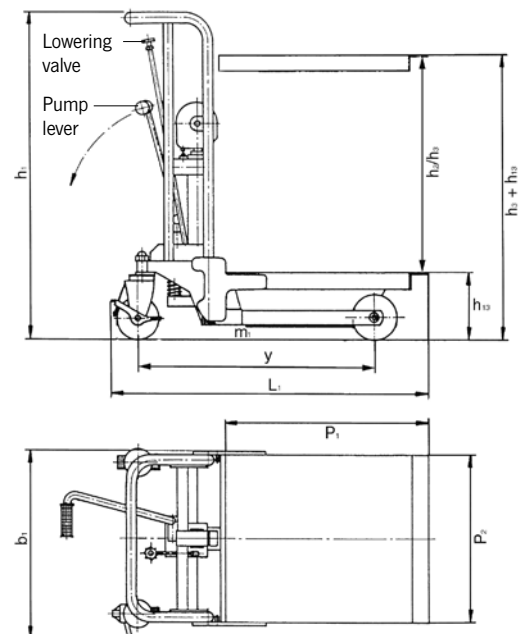



HX 150

HX Scissor elevating platform, mobile with single scissor

Capacity 150 - 750 kg,
platform height max. 1000 mm

For the independant lifting and supplying of loads within a warehouse environment.

Features

- Hydraulic lifting of the load with foot pedal.
- Lowering speed can be finely metered for sensitive lowering of the load.
- Ergonomic handlebar for easy operation, tiltable for model HX 150.
- Steering roller with brake for safe parking of the hand stacker.
- Robust construction with hard chromium plated piston and pressure relief valve.

Technical data HX

| Model | HX 150 | HX 300 | HX 500 | HX 750 |
|--|----------|----------|----------|----------|
| Art.-No. | 34600020 | 40057357 | 40057358 | 40057360 |
| Capacity, kg | 150 | 300 | 500 | 750 |
| Platform height max. $h_3 + h_{13}$, mm | 720 | 880 | 880 | 1000 |
| Platform height min. h_{13} , mm | 220 | 285 | 285 | 420 |
| Stroke h_3 , mm | 500 | 595 | 595 | 580 |
| Lifting height per pump stroke, mm | 27 | 31 | 31 | 15 |
| Overall height h_1 , mm | 960 | 984 | 984 | 990 |
| Overall length L_1 , mm | 908 | 1093 | 1093 | 1330 |
| Overall width b_1 , mm | 450 | 500 | 500 | 600 |
| Platform length P_1 , mm | 700 | 850 | 850 | 1000 |
| Platform width P_2 , mm | 450 | 500 | 500 | 510 |
| Tyre type ¹ | PUR/PUR | PUR/PUR | PUR/PUR | PUR/PUR |
| Rollers, mm | 100 x 36 | 128 x 40 | 128 x 40 | 147 x 50 |
| Number of wheels/load rollers | 2/2 | 2/2 | 2/2 | 2/2 |
| Weight, kg | 49 | 78 | 82 | 120 |

¹PUR... Polyurethane

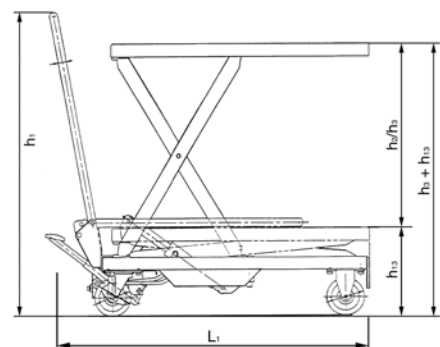
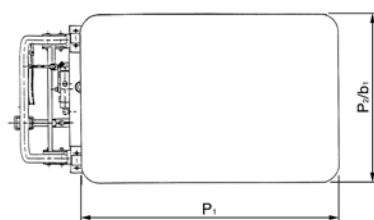

HX-D Scissor elevating platform, mobile with double scissor

Capacity 350 kg,
platform height max. 1300 mm

For the independant lifting and supplying of light up to medium loads within a warehouse environment.

Features

- Hydraulic lifting of the load with foot pedal.
- Lowering speed can be finely metered for sensitive lowering of the load.
- Ergonomic handlebar for easy operation.
- Steering roller with brake for safe parking of the hand stacker.
- Robust construction with hard chromium plated piston and pressure relief valve.
- According to EN 1570, prEN 1757-4.



Technical data HX-D

| Model | HX-D 350 |
|--|----------|
| Art.-No. | 40057361 |
| Capacity, kg | 350 |
| Platform height max. $h_3 + h_{13}$, mm | 1300 |
| Platform height min. h_{13} , mm | 370 |
| Stroke h_3 , mm | 930 |
| Lifting height per pump stroke, mm | 21 |
| Overall height h_1 , mm | 965 |
| Overall length L_1 , mm | 1140 |
| Overall width b_1 , mm | 500 |
| Platform length P_1 , mm | 910 |
| Platform width P_2 , mm | 500 |
| Tyre type ¹ | PUR/PUR |
| Load rollers, mm | 128 x 40 |
| Number of wheels/load rollers | 2/2 |
| Weight, kg | 136 |

¹PUR... Polyurethane

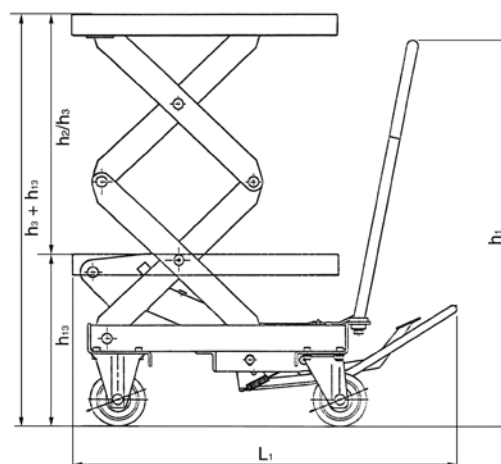
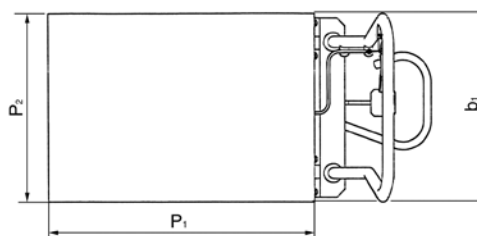



HF...SM

Scissor elevating platform,
mobile with single scissor and
- manual hydraulic

Capacity 150 - 1250 kg,
platform height max. 1050 mm

HF...SE

- electric hydraulic system

Capacity 300 - 1250 kg,
platform height max. 1050 mm

For lifting and supplying goods independent of the
location.

Features

- Manual hydraulic system with pedal or electric hydraulic system with dead man function – a main current connection is not required.
- High safety due to pressure relief and lowering valve.
- Robust single scissor construction, above 300 kg with solid steer scissor.
- Pivoting platform with mechanic adjustment for safe maintenance work.
- Compact design with low OAH.
- Steering and fixed rollers with service-free roller bearings. One steer roller can be locked in position for parking.
- According to EN 1570 and machinery directive 2006/42/EG.



Scope of delivery

- Models with electric-hydraulic pump are supplied complete with battery and charger.

Technical data HF/SM

| Model | HF 015-078 SM | HF 030-084 SM | HF 050-090 SM | HF 080-105 SM | HF 100-105 SM | HF 125-105 SM |
|---|---------------|---------------|---------------|---------------|---------------|---------------|
| Art.-No. | N24501078 | N24503084 | N24505090 | N24508105 | N24510105 | N24512105 |
| Capacity, kg | 150 | 300 | 500 | 800 | 1000 | 1250 |
| Platform height max. h_2 , mm | 780 | 840 | 900 | 1050 | 1050 | 1050 |
| Platform height min. h_1 , mm | 255 | 335 | 340 | 360 | 360 | 360 |
| Stroke h_3 , mm | 525 | 505 | 560 | 690 | 690 | 690 |
| Overall length l_1 , mm | 990 | 1050 | 1320 | 1650 | 2350 | 1650 |
| Overall width b_1 , mm | 450 | 500 | 610 | 860 | 1000 | 860 |
| Platform length l , mm | 760 | 840 | 1030 | 1350 | 2000 | 1350 |
| Platform width b_1 , mm | 450 | 500 | 610 | 840 | 1000 | 840 |
| Tyre type ¹ | VG | PUR | PUR | PA | PA | PA |
| Service brake | manual | manual | manual | manual | manual | manual |
| Number of strokes for max. lift | 14 | 18 | 29 | 40 | 80 | 80 |
| Weight (with battery and battery charger), kg | 41 | 83 | 109 | 222 | 286 | 230 |

¹PA... Polyamide, PUR... Polyurethane, VG... Solid rubber

Technical data HF/SE

| Model | HF 030-084 SE | HF 050-090 SE | HF 080-105 SE | HF 100-105 SE | HF 125-105 SE |
|---|---------------|---------------|---------------|---------------|---------------|
| Art.-No. | N24603084 | N24605090 | N24608105 | N24610105 | N24612105 |
| Capacity, kg | 300 | 500 | 800 | 1000 | 1250 |
| Platform height max. h_2 , mm | 840 | 900 | 1050 | 1050 | 1050 |
| Platform height min. h_1 , mm | 335 | 340 | 360 | 360 | 360 |
| Stroke h_3 , mm | 505 | 560 | 690 | 690 | 690 |
| Overall length l_1 , mm | 1130 | 1330 | 1650 | 2350 | 1650 |
| Overall width b_1 , mm | 500 | 610 | 860 | 1000 | 860 |
| Platform length l , mm | 840 | 1030 | 1350 | 2000 | 1350 |
| Platform width b_1 , mm | 500 | 610 | 840 | 1000 | 840 |
| Tyre type ¹ | PUR | PUR | PA | PA | PA |
| Service brake | manual | manual | manual | manual | manual |
| Number of strokes for max. lift | electric | electric | electric | electric | electric |
| Weight (with battery and battery charger), kg | 120 | 158 | 270 | 397 | 278 |

¹PA... Polyamide, PUR... Polyurethane

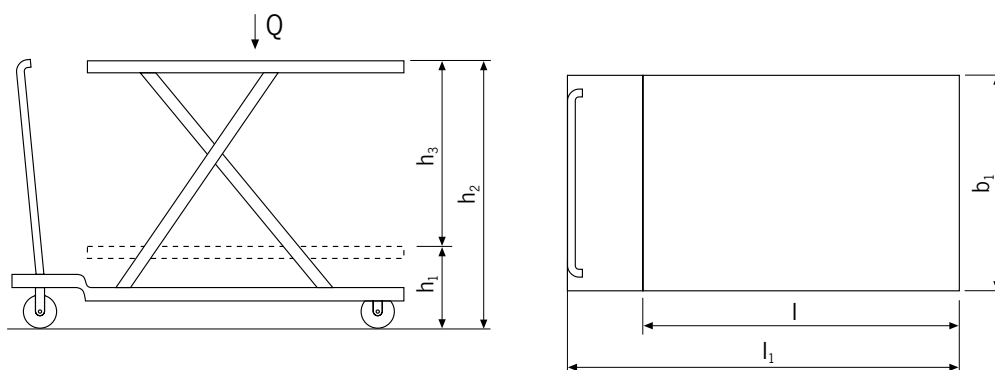



HF...DM

Scissor elevating platform,
mobile with double vertical
scissor and
- manual hydraulic

HF...DE

- electric hydraulic system

Capacity 125 - 800 kg,
platform height max. 1900 mm

For lifting and supplying goods independent of the
location.

Features

- Manual hydraulic system with pedal or electric hydraulic system with dead man function – a main current connection is not required.
- High safety due to pressure relief and lowering valve.
- Robust single scissor construction, above 300 kg with solid steer scissor.
- Pivoting platform with mechanic adjustment for safe maintenance work.
- Compact design with low OAH.
- Steering and fixed rollers with service-free roller bearings. One steer roller can be locked in position for parking.
- According to EN 1570 and machinery directive 2006/42/EG.



Scope of delivery

- Models with electric-hydraulic pump are supplied complete with battery and charger.

Technical data HF/DM

| Model | HF 012-142 DM | HF 045-155 DM | HF 050-190 DM | HF 080-190 DM |
|---|---------------|---------------|---------------|---------------|
| Art.-No. | N24701142 | N24704155 | N24705190 | N24708190 |
| Capacity, kg | 125 | 450 | 500 | 800 |
| Platform height max. h_2 , mm | 1420 | 1550 | 1900 | 1900 |
| Platform height min. h_1 , mm | 430 | 295 | 490 | 490 |
| Stroke h_3 , mm | 990 | 1255 | 1410 | 1410 |
| Overall length l_1 , mm | 1090 | 1350 | 1650 | 1650 |
| Overall width b_1 , mm | 500 | 665 | 860 | 860 |
| Platform length l , mm | 840 | 1030 | 1350 | 1350 |
| Platform width b_1 , mm | 500 | 610 | 840 | 840 |
| Tyre type ¹ | PUR | PUR | PA | PA |
| Service brake | manual | manual | manual | manual |
| Number of strokes for max. lift | 19 | 71 | 80 | 160 |
| Weight (with battery and battery charger), kg | 100 | 143 | 306 | 315 |

¹PA... Polyamide, PUR... Polyurethane

Technical data HF/DE

| Model | HF 012-142 DE | HF 045-155 DE | HF 050-190 DE | HF 080-190 DE |
|---|---------------|---------------|---------------|---------------|
| Art.-No. | N24801142 | N24804155 | N24805190 | N24808190 |
| Capacity, kg | 125 | 450 | 500 | 800 |
| Platform height max. h_2 , mm | 1420 | 1550 | 1900 | 1900 |
| Platform height min. h_1 , mm | 430 | 295 | 490 | 490 |
| Stroke h_3 , mm | 990 | 1255 | 1410 | 1410 |
| Overall length l_1 , mm | 1090 | 1350 | 1650 | 1650 |
| Overall width b_1 , mm | 500 | 665 | 860 | 860 |
| Platform length l , mm | 840 | 1030 | 1350 | 1350 |
| Platform width b_1 , mm | 500 | 610 | 840 | 840 |
| Tyre type ¹ | PUR | PUR | PA | PA |
| Service brake | manual | manual | manual | manual |
| Number of strokes for max. lift | electric | electric | electric | electric |
| Weight (with battery and battery charger), kg | 147 | 190 | 352 | 363 |

¹PA... Polyamide, PUR... Polyurethane

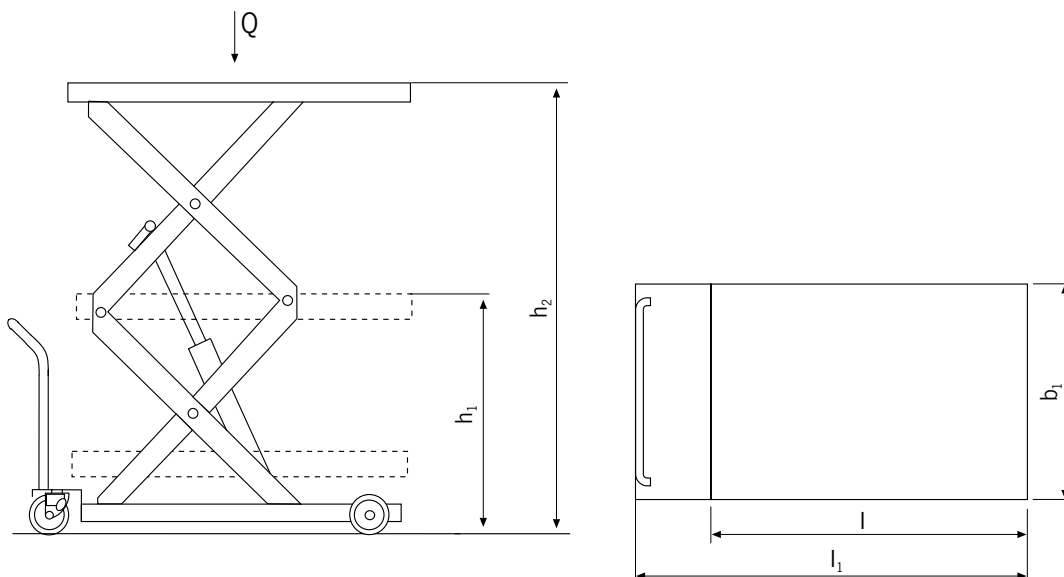



HT 08 M

Mobile elevating work bench with
- manual-hydraulic lift

HT 08 E

Mobile elevating work bench with
- electric-hydraulic lift

Capacity 800 kg,
platform height max. 1475 mm

For lifting and transporting of heavy loads in manufacturing and assembly processes.

Features

- Triplex mast for lifting heights up to 1475 mm
- Ergonomic handlebar for easy operation.
- Double-acting hand pump with increased lift per handle stroke (HT 08 M).
- Electric hydraulic unit with battery for comfortable and easy lifting (HT 08 E).
- Steering roller with brake for safe parking of the hand stacker.
- Robust construction with hard chromium plated piston.

Scope of delivery HT 08 E

- Battery and integrated battery charger.

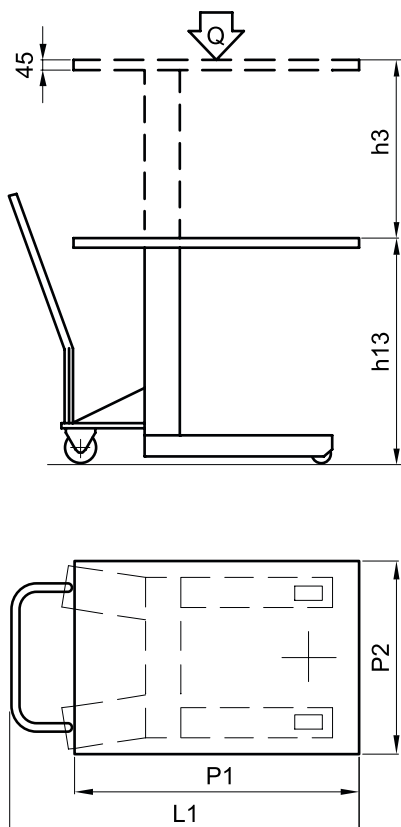

Technical data HT 08 M and HT 08 E

| Model | HT 08 M | HT 08 E |
|--------------------------------------|-----------|------------|
| Art.-No. | N24380120 | N24380129 |
| Capacity, kg | 800 | 800 |
| Platform height max. h3 + h13, mm | 1475 | 1475 |
| Platform height min. h13, mm | 700 | 700 |
| Stroke h3, mm | 775 | 775 |
| Overall length L1, mm | 980 | 980 |
| Platform length P1, mm | 800 | 800 |
| Platform width P2, mm | 750 | 750 |
| Tyre type ¹ | PUR/PUR | PUR/PUR |
| Brake | manual | manual |
| Lifting height per pump stroke, mm | 12.5 | - |
| Lifting speed with/without load, m/s | - | 0.08/0.125 |
| Hoist motor rating, kW | - | 0.8 |
| Battery voltage, V/Ah | - | 12/100 |
| Battery charger, V/A | - | 12/10 |
| Weight, kg | 134 | 152 |
| Battery weight, kg | - | 25 |

¹PUR... Polyurethane

HTF-G SILVERLINE Flat scissor lifting table

Capacity 1000 kg

For the professional lifting and handling of loads within a warehouse environment.

Features

- Extremely low-profile design reducing cost and effort for a pit-installation.
- The ramp allows loading the platform directly with a pallet truck or trolley.
- Safe operation due to push-button for up/down in dead man's control, as well as emergency stop.
- Overload protection by pressure control valve.
- Integrated pipe burst valve and mechanical rests safe maintenance and operation.
- According to EN 1570-1 and all UVV safety regulations.



Technical data HTF-G

| Model | HTF-G |
|----------------------------|----------|
| Art.-No. | 40047380 |
| Capacity, kg | 1000 |
| Platform length L, m | 1.45 |
| Platform width B, m | 1.14 |
| Platform height min. C, mm | 82 |
| Lift H, m | 0.76 |
| Lifting time, sec. | 18 |
| Motor, kW | 0.75 |
| Weight, kg | 250 |

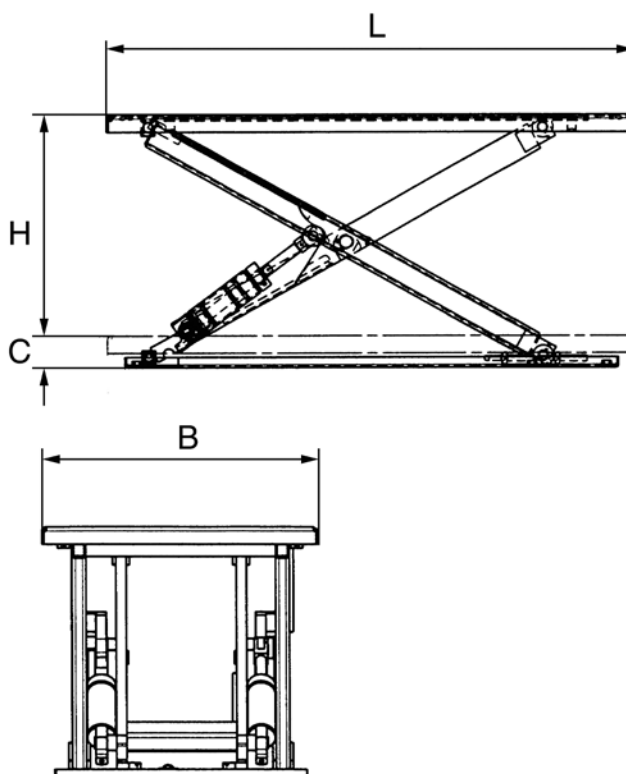

HTF-U SILVERLINE
Flat scissor lifting table

Capacity 1000 kg

For the professional lifting and handling of loads within a warehouse environment.

Features

- Extremely low-profile design lowering the cost and effort for a pit installation.
- U-design for direct access of industrial trucks.
- Safe operation due to push-button for up/down in dead man's control, as well as emergency stop.
- Overload protection by pressure control valve.
- Integrated pipe burst valve and mechanical rests safe maintenance and operation.
- According to EN 1570-1 and all UVV safety regulations.

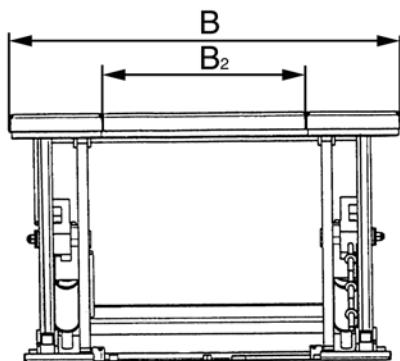
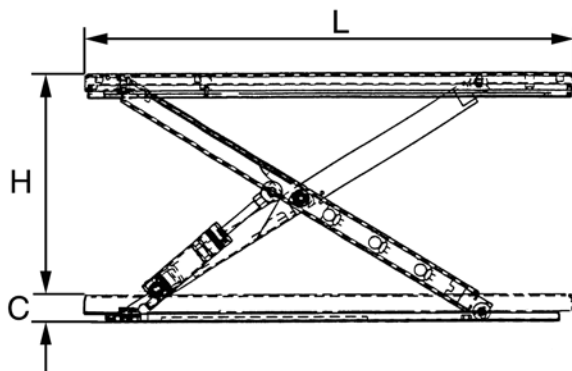

Technical data HTF-U SILVERLINE

| Model | HTF-U |
|------------------------------|----------|
| Art.-No. | 40047381 |
| Capacity, kg | 1000 |
| Platform B ₂ , mm | 585 |
| Platform length L, m | 1.45 |
| Platform width B, m | 1.14 |
| Platform height min. C, mm | 80 |
| Lift H, m | 0.76 |
| Lifting time, sec. | 18 |
| Motor, kW | 0.75 |
| Weight, kg | 235 |

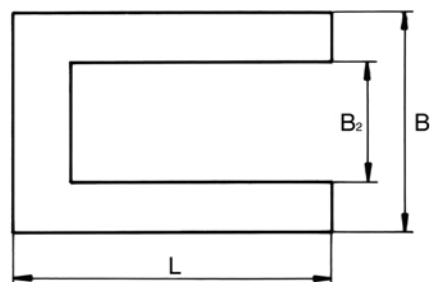

HTH-E SILVERLINE Handling table

Capacity 500 - 3000 kg

For the professional lifting and handling of heavy loads and palletised goods at workplaces

Features

- Smooth hydraulic ram action of working height for ergonomic working conditions.
- Safe operation due to push-button for up/down in dead man's control, as well as emergency stop.
- Overload protection by pressure control valve.
- Integrated pipe burst valve and mechanical rests safe maintenance and operation.
- According to EN 1570-1 and all UVV safety regulations.



Technical data HTH-E SILVERLINE

| Model | HTH-E | HTH-E | HTH-E | HTH-E |
|----------------------------|----------|----------|----------|----------|
| Art.-No. | 40049470 | 40049471 | 40049472 | 40049473 |
| Capacity, kg | 500 | 1000 | 2000 | 3000 |
| Platform length L, m | 1.3 | 1.3 | 1.3 | 1.3 |
| Platform width B, m | 0.8 | 0.8 | 0.8 | 0.8 |
| Platform height min. C, mm | 190 | 190 | 190 | 220 |
| Lift H, m | 0,82 | 0,82 | 0,82 | 0,80 |
| Lifting time, sec. | 15.0 | 25 | 40 | 26 |
| Motor, kW | 0.75 | 0.75 | 0.75 | 1.50 |
| Weight, kg | 160 | 220 | 280 | 320 |

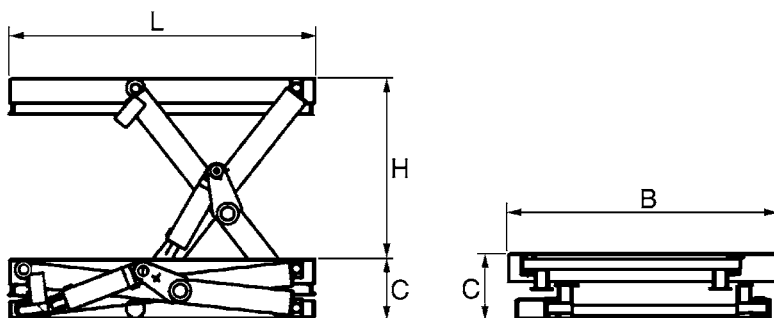

Steerman® SX und S Heavy load moving systems

Capacity 10 - 60 t

These universal heavy load moving systems have been designed for the safe and cost saving transport of loads up to 60 tons. Individual configuration of steering and rear skates also allows higher capacities.

Transport of heavy loads (e.g. machines, construction parts, steel structures) is normally made with a stable three point loading system.

Transport of extremely bulky or heavy loads with an unfavourable center of balance, may also be executed with a four point loading system. The robust towing bar in connection with the unique turntable on large diameter thrust bearings allows effortless steering of the load.

The rear skates are aligned parallel by means of a tie rod and kept in position, thus ensuring time saving and smooth transportation of the load.

The skates are powder coated and all connecting elements corrosion-resistant. Highest safety requirements have been considered.

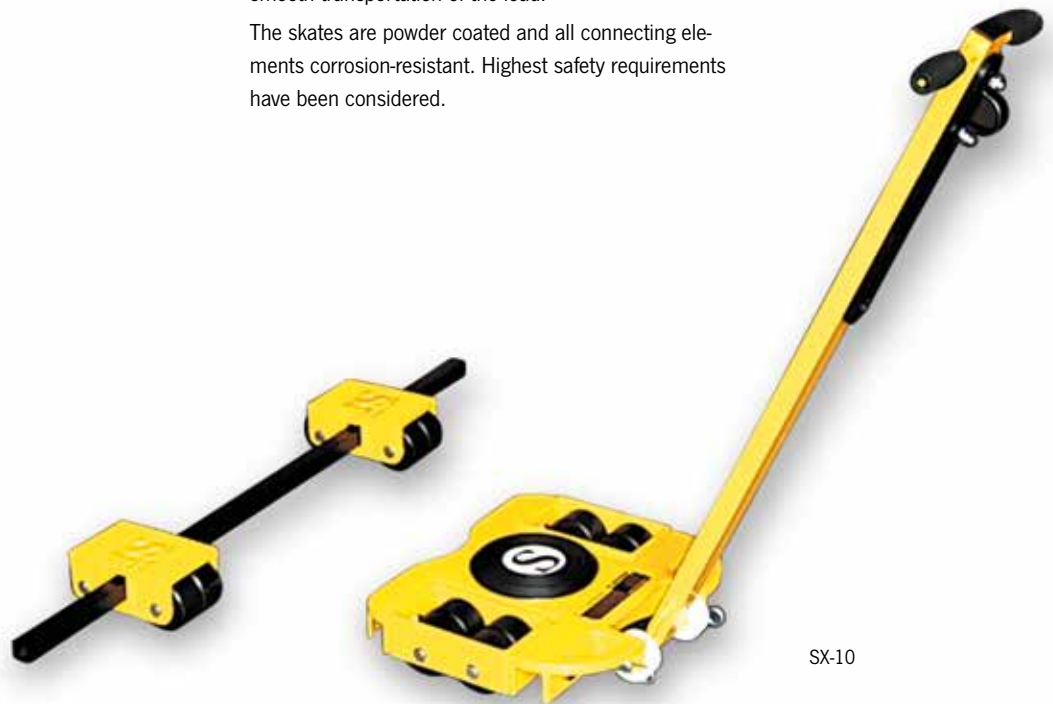

SX-10



Rollers with ball bearing



Chassis from ductile graphite iron



Ball bearing for turning plate



Features

- The modular design ensures an extremely simple operation and simultaneously offers a wider range of combinations.
- The construction of the load moving systems is extremely robust and resistant to distortion.
- The skates are smooth-running and provide an incredibly low rolling resistance even with the heaviest loads.
- Twin rollers (instead of one wide roller) ensure low rolling resistance even at a narrow curve radius.
- The universal joint suspension of the roller groups contributes to a positive contact when travelling over uneven floors.
- The roller wheels are manufactured with abrasion-resistant, elastic polyamide. They are protected against breakage and have high chemical resistance.
- Each individual roller is made from high tensile material which ensures extremely quiet running.
- The rollers are suitable for all in-plant floors and will not damage normal floor covering.
- The load moving systems can be easily dismantled and facilitate transport even in small trucks.
- The load moving systems have been developed for professional applications and are practically maintenance-free.
- All rollers are provided with two encapsulated, lifetime lubricated ball bearings.
- The front steering skate is equipped with an amply dimensioned axial ball bearing underneath the turntable.
- The front and rear skates are available individually.



S-60

Technical data Steerman® SX and S

| Model | Art.-No. | Capacity t | Overall height mm | Number of rollers | Roller diameter mm | Colour of rollers | Weight kg |
|-------|-----------|---------------|----------------------|----------------------|--------------------------|----------------------|--------------|
| SX-10 | N13600977 | 10 | 102 | 16 | 82 | black | 54 |
| SX-20 | N13600979 | 20 | 102 | 32 | 82 | black | 76 |
| SX-30 | N13600981 | 30 | 110 | 48 | 82 | black | 136 |
| S-60 | N13601094 | 60 | 170 | 48 | 115 | black | 302 |

LF Load moving skates and systems with fixed wheels

Capacity 1 - 6 t

The components of the load moving skates can be universally combined and are ideal for the transport of medium heavy loads of all kinds.

The components can be used individually or adapted to a load moving system. The units are maintenance-free.

Features

- Solid forged steel construction.
- Anti-slip rubber lining.
- Abrasion-resistant nylon wheels.
- Models LF-2,5 and above are provided with two enclosed ball bearings per wheel.



LF-1

LF-2

Technical data LF

| Model | Art.-No. | Capacity t | Wheels | Number of rollers | Wheels diameter x width mm | Dimensions L x W x H mm | Weight kg |
|--------|-----------|---------------|--------|----------------------|----------------------------------|-------------------------------|--------------|
| LF-1 | N13600006 | 1.0 | fixed | 4 | 100 x 35 | 400 x 228 x 120 | 7.0 |
| LF-2 | N13600007 | 2.0 | fixed | 8 | 100 x 35 | 400 x 228 x 120 | 8.0 |
| LF-2,5 | N13600008 | 2.5 | fixed | 2 | 85 x 90 | 275 x 120 x 100 | 4.0 |
| LF-3 | N13600009 | 3.0 | fixed | 4 | 85 x 85 | 400 x 228 x 100 | 9.5 |
| LF-6 | N13600010 | 6.0 | fixed | 6 | 85 x 85 | 415 x 210 x 100 | 12.0 |



LF-2,5

LF-3

LF-6

LFL

Load moving skates and systems with steerable wheels

Capacity 1 - 2 t

The components of the load moving skates can be universally combined and are ideal for the transport of medium heavy loads of all kinds.

The components can be used individually or adapted to a load moving system. The units are maintenance-free.

Features

- Solid forged steel construction.
- Anti-slip rubber lining.
- Abrasion-resistant nylon wheels.
- Model LFL-1-2 uses two steerable and two fixed wheels
- Model LFL-1-4 and LFL-2-4 uses four steerable wheels.



LFL-1-2

Technical data LFL

| Model | Art.-No. | Capacity t | Wheels | Number of rollers | Swivel roller diameter x width mm | Fixed roller diameter x width mm | Dimensions L x W x H mm | Weight kg |
|---------|-----------|---------------|--------------------------|----------------------|---|--|-------------------------------|--------------|
| LFL-1-2 | N13600011 | 1.0 | 2 x fixed, 2 x steerable | 4 | 75 x 46 | 100 x 35 | 430 x 340 x 120 | 13.0 |
| LFL-1-4 | N13600012 | 1.0 | 4 x steerable | 4 | 75 x 46 | - | 430 x 340 x 120 | 14.0 |
| LFL-2-4 | 192025595 | 2.0 | 4 x steerable | 4 | 80 x 40 | - | 430 x 400 x 130 | 20.0 |



LFL-1-4

Load Moving Systems

LX Heavy load moving system

Capacity 6 t and 12 t

These three point loading systems comprise of a steerable front and a pair of adjustable rear skates.

The heavy load moving systems are supplied ready-to-use.

The steerable front skates (LX-6F and LX-12F) are provided with an appropriate towing bar. The rear skates (LX-12R) are identical in construction and are equipped with two adjustable tie rods.

The wheels are made of hardwearing nylon.

The front and rear skates can accept each 50% of the total capacity.



LX-6

Technical data LX

| Model | Art.-No. | Capacity t | Number of wheels front skate | Number of wheels rear skate | Wheels diameter x width mm | Load area front skate mm | Load area rear skate mm | Adjustment range rear skates mm | Height mm | Weight kg |
|-------|-----------|---------------|------------------------------------|-----------------------------------|----------------------------------|--------------------------------|-------------------------------|--|--------------|--------------|
| LX-6 | N13600004 | 6.0 | 4 | 8 | 85 x 90 | 185 x 150 | 300 x 250 | 500 - 1400 | 115 | 45.0 |
| LX-12 | N13600005 | 12.0 | 8 | 8 | 85 x 90 | 400 x 220 | 300 x 250 | 500 - 1400 | 115 | 80.0 |



LX-12



Hydraulic jacks & tools

A characteristic of this “force-oriented” hydraulic programme is the operating pressure which can be as high as 700 bar. This guarantees a simple and safe generation of highest forces. In spite of this the units remain compact, portable and easy to operate. High-pressure hydraulic systems of this type are used in universal assembly and repair operations whereby their application in day-to-day operations is almost unlimited. The component programme allows the individual configuration of simple and also complex system solutions.

They are used in the following main industrial areas:

Heavy industry, mining, shipbuilding, offshore, aviation industries, power stations, steel construction, steel making and processing, building construction, bridge and tunnel construction, heavy steel and tank construction, metal processing workshops, and many more.

INFO

Please note our user instructions at the beginning of each chapter.

Table of contents

| | Page |
|-------------------------------------|-----------|
| Hydraulic cylinders, single-acting | 334 - 343 |
| | 352 - 355 |
| Hydraulic cylinders, double-acting | 344 - 351 |
| Accessories for hydraulic cylinders | 356 - 359 |
| Hand pumps 700 bar | 360 - 365 |
| Hand pumps up to 2000 bar | 366 |
| Foot pump 700 bar | 367 |
| Electric & Pneumatic motor pumps | 368 - 373 |
| Electric hydraulic power packs | 374 - 379 |
| Valves & Accessories | 380 - 393 |
| Puller | 394 - 399 |
| Jacks | 400 - 407 |
| Hydraulic jacks & tools | 408 - 409 |
| Test rigs | 410 - 411 |
| Presses | 412 - 414 |
| Selection & Speed charts | 415 - 419 |

Yale

HYDRAULIC JACKS & TOOLS



OFFLINE

Why hydraulics?

Hydraulics is the kind of power transmission which allows the greatest density of forces. There is no other kind of power transmission that will transmit comparable high forces with the same construction size.

Hydraulic tools

Hydraulic tools are a special type of power tools, which can be used for general assembly and repair jobs with preferably high force in lowest spaces.

Simple applications, clearness of the programme in line with robustness, short-term deliveries and universal operation possibilities have made Yale hydraulic components indispensable tools also for elaborate functions.

The unlimited power of hydraulic tools is used in applications like lifting, levelling and positioning of heaviest loads, installations of machines, assembly of complex structures as well as in general repair of maintenance jobs.

The components can also be operated in fixtures for clamping, testing, pressing, extracting, crimping, cutting, riveting and many more.

How to reach high forces in hydraulics?

| | | | | |
|-----------------------|---|-----------------|---|-------|
| area | x | pressure | = | force |
| effective piston area | x | system pressure | = | force |
| cm ² | x | bar | = | daN |

Example: Hydraulic cylinder YS-10/

| | | | | |
|----------------------|---|---------|---|-----------|
| 14.3 cm ² | x | 700 bar | = | 10010 daN |
| | | | = | 100 kN |
| | | | = | 10 t |

Linear conversion of pressure force

The above formula shows that pressure forces can be converted linearly.

Example:

A 10 ton cylinder presses at:

| | | | | |
|---------|---|---------|---|---------|
| 700 bar | - | 100 kN | = | 10 t |
| 350 bar | - | 50 kN | = | 5 t |
| 100 bar | - | 14 kN | = | 1.4 t |
| 1 bar | - | 0.14 kN | = | 0.014 t |

INFO

Der Systemdruck bestimmt die Kraft des Hydraulikzylinders. Die Fördermenge bestimmt die Ausfahrgeschwindigkeit.

Basic terms in hydraulics

Pressure

is the system pressure generated by the pump, which, however, can also be produced by an external power source, which acts on the hydraulic cylinder.

Force

is always the pressure transferred by the hydraulic cylinder (only with counterpressure).

Stroke

is the travel distance to be achieved by the force (no-load stroke, loaded stroke, return stroke).

Piston travel speed

Is the time, in which the piston of the hydraulic cylinder is to pass a certain travel distance (stroke) (no-load stroke + loaded stroke, return stroke).

Hydraulic cylinders

are available in many different designs, however, with only two basic function principles:

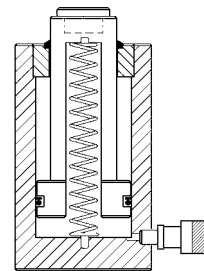

single-acting

The piston travel is achieved via hydraulic pressure and returned by spring activation (pressure build-up in one direction only).

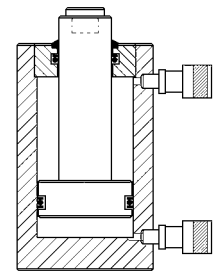

double-acting

The piston travel is achieved via hydraulic pressure in both directions. (Push forces and pulling forces are possible).



Hydraulic hand pumps

The function of a hydraulic hand pump is to convey hydraulic oil (no-load stroke) and to generate pressure, which will be converted by the hydraulic cylinder into force (loaded stroke). Hydraulic hand pumps are independent from energy and can be used in every-day applications. They are easily portable and render an extremely high power generation in connection with a corresponding hydraulic cylinder.

Hand pumps require certain manpower and are often replaced by motor pumps in case of permanent duty and high oil quantities, respectively.

Hand pumps are distinguished by:

1. oil displacement volume (1st stage / 2nd stage).
2. the function of the hydraulic cylinder: single-acting / double-acting.

Motor pumps

transmit an oil flow as soon as the pump unit is driven by the electric motor. Contrary to hand pumps, the oil flow is also available when the hydraulic cylinder is not activated (e.g. during work breaks).



Hydraulic valves

Valves are used in hydraulics to control the oil flow (generated by either hand or motor pump) in terms of direction, pressure and oil volume.

Directional valves

are required to control the direction of the oil flow and thus the work motions of the connected hydraulic cylinder (advance - hold - return).

Depending on the type of pump and cylinder, 2-, 3- or 4-way valves may be employed.

3/3-way valves for single-acting cylinders

4/3-way valves for double-acting cylinders

Controls are available with either manual or electro-magnetic valves (the latter with remote cable control).

Pressure valves

are employed to limit the system pressure in a hydraulic system or within a part of the oil circuit. Pressure valves or pressure relief valves are also installed as safety devices in order to avoid excessive increase of the system pressure beyond a given value.

Shut-off and throttle valves

are used to easily shut-off hydraulic lines by hand. On account of their sensible control mode, these valves can also be applied to throttle an oil flow and thus to control the piston advance at both lifting or lowering of the load.

Safety check valves

are used for those applications where pressure drops must be avoided.

Pressure switch

can be set to any pressure value in order to switch on/off parts of the hydraulic circuit.

For your safety

Hydraulic units are extremely robust and durable. Nevertheless you should observe the following instructions for your own safety and to increase the life expectancy of the product:

- Never exceed the max. pressure (capacity) of the hydraulic units.
- Avoid eccentric loading of the piston.
- The load must always be positioned centric and parallel on the piston. Avoid point loading!
- Never pass under a raised load, if this is not supported additionally.
- Hydraulic units must be kept clear of heat (e.g. during welding).
- Protect hydraulic hoses against damage and strong kinks. Hydraulic hoses should lie freely in a wide curve. Avoid tensile load.

Eccentric loading

In order to obtain a long life expectancy, hydraulic cylinders series YS, YLS, YFS, YCS, YCH, YH and YPL are manufactured from chromium-molybdenum steel, the cylinder housings and piston rods are hardened and tempered and provided with bronze guides. Generally, hydraulic cylinders should not be loaded eccentrically, as this can lead to reduced lifetime. In practice, a lateral loading cannot be fully avoided. In this case the maximum system pressure and the stroke of the cylinder should only be used by 50%. Ensure that the load always rests on the total area of the steel saddle and the piston, respectively. Also ensure that the entire bottom area of the hydraulic cylinder always stands on a level, sustainable ground surface.

This applies especially to flat cylinders!

Repairs

Repair and maintenance should be performed by qualified personnel only. Make sure to use original spare parts only.





Hydraulic cylinders with Yale Chro-Mo-Design

Yale hydraulic tools are designed for professional operation. A tool is only as good as its basic material. Therefore, our cylinders are manufactured from high quality chromium-molybdenum steel and are heat-treated.

Double bronze bearings

Practice has shown that hydraulic cylinders used as a tool in workshops or on construction sites are frequently subjected to eccentric loading. Yale hydraulic cylinders are provided with double bronze bearings on the plunger, which minimizes friction between plunger and body during lateral loading.

Hard chromium-plated piston

Offers excellent protection against mechanical damage and corrosion. Excellent sliding characteristics in conjunction with the upper bronze bearing in the stop ring.

Metric mounting threads and standard parts

To facilitate the installation of hydraulic cylinders in jigs and fixtures and auxiliary structures. The metric standard throughout the entire series simplifies service operations and repairs. Cylinders carry the full load even under maximum operating pressure.

Stop ring carries full pressure

As a safety factor the stop ring on all Yale hydraulic cylinders carries the full load even under maximum operating pressure.

Delivered ready to use

Yale Hydraulic cylinders are delivered ready to use incl. female coupler half, hardened saddle and mounting threads; larger cylinders come with carrying handle or transportation lugs. This also applies to customised combinations which are always supplied fully assembled.

Hardened alloy steel saddle

Metric mounting threads in cylinder base, plunger and cylinder collar (depending on series)

Two bronze bearings minimize friction even in cases of eccentric loading

INFO



Dirt wiper protects against dirt

Stop ring prevents over-stroking of the piston up to full operating pressure

Hard chromium-plated plunger

Piston and ...

... cylinder housing are made from chromium-molybdenum steel and are heat-treated.

Female coupler half CFY-1 (incl. dust cap)



YS

Universal cylinder

Single-acting with spring return,
capacity 5 - 100 t

Robust construction with long guides allows the units to withstand abuse and better tolerate eccentric and side loading, yet is convenient to use with only one quick-release coupler hose connection and a spring return.

Universal cylinders are designed for all jobs where high forces but compact dimensions are required: e.g. straightening steel constructions, removing parts like shafts, axles, lifting, positioning, weighing, supporting, testing as well as for all general assembly and repair applications. Due to the various mounting threads the cylinders can easily be installed in clamping devices, welding fixtures, frame presses etc.

Features

- Yale ChroMo-Design.
- Operating pressure max. 700 bar.
- Single-acting with spring return.
- Robust design with long piston bearings to withstand eccentric loading.
- Cylinder body and piston are made from solid chromium-molybdenum steel and heat-treated.
- Hard-chromium plated piston with replaceable, heat-treated saddle.
- Metric mounting threads on cylinder collar, in the base and piston rod (5 to 30t).
- Stop ring can bear full capacity (pressure) and is fitted with dirt wiper.
- Interchangeable hardened saddle.
- Dirt wiper protects against dirt.
- Oil port thread 3/8 NPT.
- Incl. female coupler half model CFY-1.
- YS-50/100 and YS-50/160 with carrying handle, YS-50/320 up to YS-100/200 with lifting rings.

INFO

Selection charts "cylinder/hand pumps" can be found on pages 416-417.

Travel-speed charts are supplied on pages 418-419.

Technical data YS

| Cylinder size | Model | Art.-No. | Capacity | Stroke | Effective plunger area | Oil volume max. | Closed height | Cylinder outside diameter | Weight |
|---------------|------------|-----------|----------|--------|------------------------|-----------------|---------------|---------------------------|--------|
| t | | | kN | mm | cm ² | cm ³ | mm | mm | kg |
| 5 | YS-5/15 | N11100001 | 50 | 15 | 7.2 | 11 | 45 | 41 | 0.9 |
| 5 | YS-5/25 | N11100002 | 50 | 25 | 7.2 | 18 | 97 | 42 | 1.0 |
| 5 | YS-5/75 | N11100003 | 50 | 75 | 7.2 | 53 | 157 | 42 | 1.5 |
| 5 | YS-5/127 | N11100004 | 50 | 127 | 7.2 | 90 | 214 | 42 | 2.0 |
| 5 | YS-5/180 | N11100005 | 50 | 180 | 7.2 | 127 | 267 | 42 | 2.4 |
| 10 | YS-10/25 | N11100006 | 100 | 25 | 14.3 | 37 | 90 | 57 | 1.6 |
| 10 | YS-10/50 | N11100007 | 100 | 50 | 14.3 | 73 | 125 | 57 | 2.1 |
| 10 | YS-10/100 | N11100008 | 100 | 100 | 14.3 | 146 | 178 | 57 | 2.8 |
| 10 | YS-10/150 | N11100009 | 100 | 150 | 14.3 | 218 | 250 | 57 | 4.1 |
| 10 | YS-10/200 | N11100010 | 100 | 200 | 14.3 | 291 | 300 | 57 | 4.7 |
| 10 | YS-10/250 | N11100011 | 100 | 250 | 14.3 | 363 | 352 | 57 | 5.5 |
| 10 | YS-10/300 | N11100012 | 100 | 300 | 14.3 | 436 | 407 | 57 | 6.3 |
| 15 | YS-15/25 | N11100013 | 150 | 25 | 21.5 | 53 | 110 | 67 | 2.7 |
| 15 | YS-15/50 | N11100014 | 150 | 50 | 21.5 | 106 | 140 | 67 | 3.3 |
| 15 | YS-15/100 | N11100015 | 150 | 100 | 21.5 | 213 | 190 | 67 | 4.3 |
| 15 | YS-15/150 | N11100016 | 150 | 150 | 21.5 | 319 | 260 | 67 | 5.8 |
| 15 | YS-15/200 | N11100017 | 150 | 200 | 21.5 | 425 | 310 | 67 | 7.0 |
| 15 | YS-15/250 | N11100018 | 150 | 250 | 21.5 | 531 | 365 | 67 | 8.0 |
| 15 | YS-15/300 | N11100019 | 150 | 300 | 21.5 | 637 | 420 | 67 | 9.0 |
| 15 | YS-15/350 | N11100020 | 150 | 350 | 21.5 | 744 | 472 | 67 | 10.0 |
| 23 | YS-23/25 | N11100021 | 230 | 25 | 32.9 | 83 | 116 | 85 | 5.0 |
| 23 | YS-23/50 | N11100022 | 230 | 50 | 32.9 | 166 | 150 | 85 | 6.0 |
| 23 | YS-23/100 | N11100023 | 230 | 100 | 32.9 | 332 | 202 | 85 | 7.5 |
| 23 | YS-23/160 | N11100024 | 230 | 160 | 32.9 | 531 | 277 | 85 | 10.0 |
| 23 | YS-23/210 | N11100025 | 230 | 210 | 32.9 | 697 | 330 | 85 | 12.0 |
| 23 | YS-23/250 | N11100026 | 230 | 250 | 32.9 | 830 | 376 | 85 | 13.5 |
| 23 | YS-23/300 | N11100027 | 230 | 300 | 32.9 | 996 | 428 | 85 | 15.0 |
| 23 | YS-23/345 | N11100028 | 230 | 345 | 32.9 | 1145 | 477 | 85 | 16.5 |
| 30 | YS-30/125 | N11100029 | 300 | 125 | 42.9 | 552 | 245 | 102 | 13.0 |
| 30 | YS-30/200 | N11100030 | 300 | 200 | 42.9 | 884 | 325 | 102 | 17.0 |
| 50 | YS-50/50 | N11100031 | 500 | 50 | 71.5 | 355 | 170 | 125 | 15.0 |
| 50 | YS-50/100 | N11100032 | 500 | 100 | 71.5 | 709 | 220 | 125 | 19.0 |
| 50 | YS-50/160 | N11100033 | 500 | 160 | 71.5 | 1135 | 285 | 125 | 24.0 |
| 50 | YS-50/320 | N11100034 | 500 | 320 | 71.5 | 2269 | 460 | 125 | 37.0 |
| 70 | YS-70/150 | N11100035 | 700 | 150 | 100.0 | 1478 | 285 | 146 | 32.0 |
| 70 | YS-70/330 | N11100036 | 700 | 330 | 100.0 | 3252 | 490 | 146 | 52.0 |
| 100 | YS-100/100 | N11100476 | 1000 | 100 | 143.0 | 1432 | 275 | 180 | 43.0 |
| 100 | YS-100/200 | N11100037 | 1000 | 200 | 143.0 | 2863 | 375 | 180 | 64.0 |



Accessories for YS cylinders like lifting claws, piston plates, base adaptors, extension tubes, support plates and threaded flanges are also available



Support plates are available as accessories



Threaded flanges are available as accessories

INFO

For accessories for cylinders series YS please see pages 356 - 358.

Hydraulic Jacks & Tools Hydraulic cylinders, single-acting

Dimensions YS

| Model | YS-5/15 | YS-5/25 | YS-5/75 | YS-5/127 | YS-5/180 | YS-10/25 | YS-10/50 | YS-10/100 | YS-10/150 | YS-10/200 |
|-------|-----------|-----------|-----------|-----------|-----------|-----------|-----------|-----------|-----------|-----------|
| A, mm | 45 | 97 | 157 | 214 | 267 | 90 | 125 | 178 | 250 | 300 |
| B, mm | 60 | 122 | 232 | 341 | 447 | 115 | 175 | 278 | 400 | 500 |
| C, mm | 45 | 92 | 152 | 209 | 262 | 88 | 119 | 172 | 244 | 294 |
| D, mm | 41 | 42 | 42 | 42 | 42 | 57 | 57 | 57 | 57 | 57 |
| E, mm | 30 | 30 | 30 | 30 | 30 | 43 | 43 | 43 | 43 | 43 |
| F, mm | 25 | 26 | 26 | 26 | 26 | 38 | 38 | 38 | 38 | 38 |
| H, mm | 19 | 19 | 19 | 19 | 19 | 17 | 19 | 19 | 21 | 21 |
| J, mm | - | 25 | 25 | 25 | 25 | - | 35 | 35 | 35 | 35 |
| K, mm | - | 5 | 5 | 5 | 5 | 3 | 6 | 6 | 6 | 6 |
| O, mm | - | M20 x 2 | M20 x 2 | M20 x 2 | M20 x 2 | - | M27 x 2 | M27 x 2 | M27 x 2 | M27 x 2 |
| P, mm | - | 13 | 13 | 13 | 13 | - | 17 | 17 | 22 | 22 |
| S, mm | - | - | - | - | - | - | - | - | - | - |
| U, mm | 28.5 | 28 | 28 | 28 | 28 | 35 | 35 | 35 | 35 | 35 |
| V, mm | 2 x 5.5 Ø | 2 x M6 | 2 x M6 | 2 x M6 | 2 x M6 | 2 x M8 | 2 x M8 | 2 x M8 | 2 x M8 | 2 x M8 |
| W, mm | - | 23 | 23 | 23 | 23 | 27 | 27 | 27 | 27 | 27 |
| X, mm | - | M42 x 1.5 | M42 x 1.5 | M42 x 1.5 | M42 x 1.5 | M57 x 1.5 | M57 x 1.5 | M57 x 1.5 | M57 x 1.5 | M57 x 1.5 |
| Z, ° | 5 | 5 | 5 | 5 | 5 | 5 | 5 | 5 | - | - |

| Model | YS-10/250 | YS-10/300 | YS-15/25 | YS-15/50 | YS-15/100 | YS-15/150 | YS-15/200 | YS-15/250 | YS-15/300 | YS-15/350 |
|-------|-----------|-----------|-----------|-----------|-----------|-----------|-----------|-----------|-----------|-----------|
| A, mm | 352 | 407 | 110 | 140 | 190 | 260 | 310 | 365 | 420 | 472 |
| B, mm | 602 | 707 | 135 | 190 | 290 | 410 | 510 | 615 | 720 | 822 |
| C, mm | 346 | 401 | 103 | 133 | 183 | 253 | 303 | 358 | 413 | 465 |
| D, mm | 57 | 57 | 67 | 67 | 67 | 67 | 67 | 67 | 67 | 67 |
| E, mm | 43 | 43 | 52 | 52 | 52 | 52 | 52 | 52 | 52 | 52 |
| F, mm | 38 | 38 | 46 | 46 | 46 | 46 | 46 | 46 | 46 | 46 |
| H, mm | 21 | 21 | 19 | 19 | 19 | 22 | 22 | 22 | 22 | 22 |
| J, mm | 35 | 35 | 40 | 40 | 40 | 40 | 40 | 40 | 40 | 40 |
| K, mm | 6 | 6 | 7 | 7 | 7 | 7 | 7 | 7 | 7 | 7 |
| O, mm | M27 x 2 | M27 x 2 | M33 x 2 | M33 x 2 | M33 x 2 | M33 x 2 | M33 x 2 | M33 x 2 | M33 x 2 | M33 x 2 |
| P, mm | 22 | 22 | 19 | 19 | 19 | 25 | 25 | 25 | 25 | 25 |
| S, mm | - | - | - | - | - | - | - | - | - | - |
| U, mm | 35 | 35 | 42 | 42 | 42 | 42 | 42 | 42 | 42 | 42 |
| V, mm | 2 x M8 | 2 x M8 | 2 x M10 | 2 x M10 | 2 x M10 | 2 x M10 | 2 x M10 | 2 x M10 | 2 x M10 | 2 x M10 |
| W, mm | 27 | 27 | 33 | 33 | 33 | 33 | 33 | 33 | 33 | 33 |
| X, mm | M57 x 1.5 | M57 x 1.5 | M67 x 1.5 | M67 x 1.5 | M67 x 1.5 | M67 x 1.5 | M67 x 1.5 | M67 x 1.5 | M67 x 1.5 | M67 x 1.5 |
| Z, ° | - | - | 5 | 5 | 5 | - | - | - | - | - |

| Model | YS-23/25 | YS-23/50 | YS-23/100 | YS-23/160 | YS-23/210 | YS-23/250 | YS-23/300 | YS-23/345 | YS-30/125 | YS-30/200 |
|-------|----------|----------|-----------|-----------|-----------|-----------|-----------|-----------|-----------|-----------|
| A, mm | 116 | 150 | 202 | 277 | 330 | 376 | 428 | 477 | 245 | 325 |
| B, mm | 141 | 200 | 302 | 437 | 540 | 626 | 728 | 822 | 370 | 525 |
| C, mm | 113 | 142 | 194 | 269 | 322 | 368 | 420 | 469 | 235 | 315 |
| D, mm | 85 | 85 | 85 | 85 | 85 | 85 | 85 | 85 | 102 | 102 |
| E, mm | 65 | 65 | 65 | 65 | 65 | 65 | 65 | 65 | 75 | 75 |
| F, mm | 56 | 56 | 56 | 56 | 56 | 56 | 56 | 56 | 65 | 65 |
| H, mm | 20 | 22 | 22 | 22 | 22 | 22 | 22 | 22 | 25 | 25 |
| J, mm | 50 | 50 | 50 | 50 | 50 | 50 | 50 | 50 | 50 | 50 |
| K, mm | 3 | 8 | 8 | 8 | 8 | 8 | 8 | 8 | 10 | 10 |
| O, mm | M40 x 2 | M40 x 2 | M40 x 2 | M40 x 2 | M40 x 2 | M40 x 2 | M40 x 2 | M40 x 2 | M36 x 2 | M36 x 2 |
| P, mm | 15 | 22 | 22 | 25 | 25 | 25 | 25 | 25 | 25 | 25 |
| S, mm | - | - | - | - | - | - | - | - | - | - |
| U, mm | 55 | 55 | 55 | 55 | 55 | 55 | 55 | 55 | 75 | 75 |
| V, mm | 4 x M10 | 4 x M10 | 4 x M10 | 4 x M10 | 4 x M10 | 4 x M10 | 4 x M10 | 4 x M10 | 4 x M10 | 4 x M10 |
| W, mm | 40 | 40 | 40 | 40 | 40 | 40 | 40 | 40 | 45 | 45 |
| X, mm | M85 x 2 | M85 x 2 | M85 x 2 | M85 x 2 | M85 x 2 | M85 x 2 | M85 x 2 | M85 x 2 | M102 x 2 | M102 x 2 |
| Z, ° | 5 | - | - | - | - | - | - | - | - | - |

Dimensions YS

| Model | YS-50/50 | YS-50/100 | YS-50/160 | YS-50/320 | YS-70/150 | YS-70/330 | YS-100/100 | YS-100/200 |
|-------|----------|-----------|-----------|-----------|-----------|-----------|------------|------------|
| A, mm | 170 | 220 | 285 | 460 | 285 | 490 | 275 | 375 |
| B, mm | 220 | 320 | 445 | 780 | 435 | 820 | 375 | 575 |
| C, mm | 165 | 215 | 280 | 455 | 280 | 485 | 270 | 370 |
| D, mm | 125 | 125 | 125 | 125 | 146 | 146 | 180 | 180 |
| E, mm | 95 | 95 | 95 | 95 | 112 | 112 | 135 | 135 |
| F, mm | 85 | 85 | 85 | 85 | 95 | 95 | 115 | 115 |
| H, mm | 29 | 29 | 29 | 29 | 30 | 30 | 60 | 60 |
| J, mm | 70 | 70 | 70 | 70 | 80 | 80 | 100 | 100 |
| K, mm | 5 | 5 | 5 | 5 | 5 | 5 | 5 | 5 |
| O, mm | 4 x M8 | 4 x M8 | 4 x M8 | 4 x M8 | 4 x M8 | 4 x M8 | 4 x M10 | 4 x M10 |
| P, mm | - | - | - | - | - | - | - | - |
| S, mm | - | 51 | 51 | 24 | 24 | 24 | 24 | 24 |
| U, mm | 95 | 95 | 95 | 95 | 110 | 110 | 145 | 145 |
| V, mm | 4 x M12 | 4 x M12 | 4 x M12 | 4 x M12 | 4 x M12 | 4 x M12 | 4 x M12 | 4 x M12 |
| W, mm | 50 | 50 | 50 | 50 | 60 | 60 | 70 | 70 |
| X, mm | M125 x 2 | M125 x 2 | M125 x 2 | M125 x 2 | M146 x 3 | M146 x 3 | M180 x 3 | M180 x 3 |
| Z, ° | - | - | - | - | - | - | - | - |

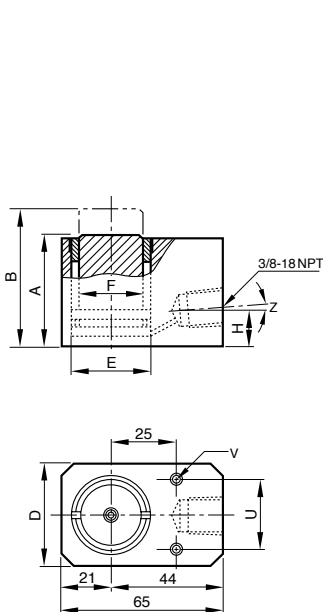

YS-5/15

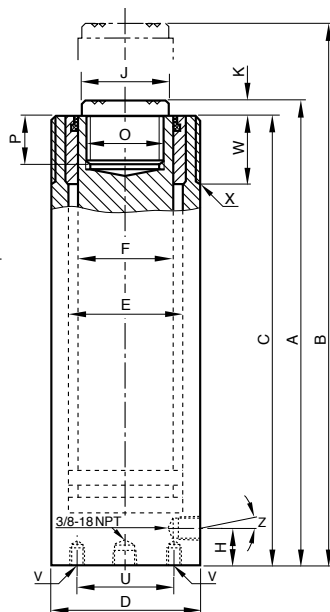

YS-5/25 up to YS-30/200

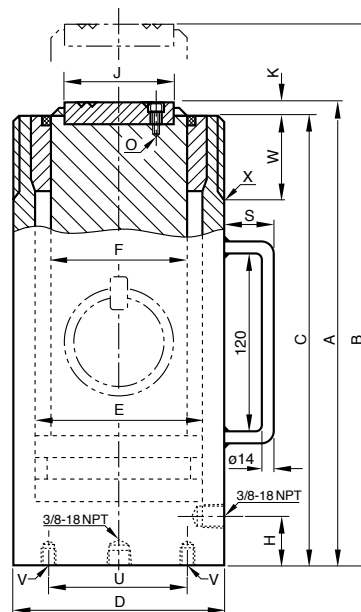

YS-50/50 up to YS-100/200

INFO

Subject to changes.



YLS



YFS

YLS and YFS Low-height and flat cylinders

Single-acting with spring return,
capacity max. 10 - 100 t

Low-height cylinders are recommended for all lifting, pushing, levelling, pressing applications especially in tight working areas.

These very compact hydraulic cylinders are designed for lifting and positioning jobs as well as all general maintenance applications, where low height, portability and light weight are needed. These versatile cylinders are found in all industrial areas like steel mills, civil engineering, heavy construction industry, power plants, off-shore industries etc. Due to their short strokes flat cylinders should not be subjected to side loading.

Features

- Yale ChroMo-Design.
- Operating pressure max. 700 bar.
- Single-acting with spring return.
- Low height for tight working areas.
- Cylinder body and piston are made from solid chromium-molybdenum steel and heat-treated.
- Stop ring can bear full capacity (pressure) and is fitted with dirt wiper.
- Oil port thread 3/8 NPT.
- Incl. female coupler half model CFY-1.
- YLS-100/55 with lifting rings,
YFS-100/15 with carrying handle.

INFO

Selection charts "cylinder/hand pumps" can be found on pages 416-417.

Travel-speed charts are supplied on pages 418-419.



Technical data YLS

| Cylinder size | Model | Art.-No. | Capacity max. | Stroke | Effective plunger area | Oil volume max. | Closed height | Cylinder outside diameter | Weight |
|---------------|------------|-----------|---------------|--------|------------------------|-----------------|---------------|---------------------------|--------|
| t | | | kN | mm | cm ² | cm ³ | mm | mm | kg |
| 10 | YLS-10/35 | N11300634 | 100 | 35 | 14.3 | 51 | 86 | 70 | 2.5 |
| 20 | YLS-20/45 | N11300635 | 200 | 45 | 28.6 | 128 | 100 | 85 | 4.0 |
| 30 | YLS-30/60 | N11300636 | 300 | 60 | 42.9 | 266 | 120 | 100 | 6.5 |
| 50 | YLS-50/60 | N11300637 | 500 | 60 | 71.5 | 426 | 122 | 125 | 10.4 |
| 100 | YLS-100/55 | N11300638 | 1000 | 55 | 143.0 | 788 | 141 | 170 | 24.0 |

Technical data YFS

| Cylinder size | Model | Art.-No. | Capacity max. | Stroke | Effective plunger area | Oil volume max. | Closed height | Cylinder outside diameter | Weight |
|---------------|------------|-----------|---------------|--------|------------------------|-----------------|---------------|---------------------------|--------|
| t | | | kN | mm | cm ² | cm ³ | mm | mm | kg |
| 10 | YFS-10/11 | N11300629 | 100 | 11 | 14.3 | 16 | 43 | 56 | 1.5 |
| 20 | YFS-20/15 | N11300630 | 200 | 15 | 28.6 | 31 | 60 | 76 | 3.0 |
| 30 | YFS-30/15 | N11300631 | 300 | 15 | 44.2 | 66 | 60 | 96 | 4.2 |
| 50 | YFS-50/15 | N11300632 | 500 | 15 | 71.5 | 107 | 70 | 145 | 8.7 |
| 100 | YFS-100/15 | N11300633 | 1000 | 15 | 143.0 | 215 | 91 | 170 | 16.0 |

Dimensions YLS and YFS

| Model | YLS-10/35 | YLS-20/45 | YLS-30/60 | YLS-50/60 | YLS-100/55 | YFS-10/11 | YFS-20/15 | YFS-30/15 | YFS-50/15 | YFS-100/15 |
|--------|-----------|-----------|-----------|-----------|------------|-----------|-----------|-----------|-----------|------------|
| A, mm | 86 | 100 | 120 | 122 | 141 | 43 | 60 | 60 | 70 | 91 |
| B, mm | 121 | 145 | 180 | 182 | 196 | 54 | 75 | 75 | 85 | 106 |
| D, mm | 70 | 85 | 100 | 125 | 170 | 56 | 76 | 96 | 145 | 170 |
| D1, mm | - | - | - | - | - | 83 | 95 | 115 | - | - |
| E, mm | 43 | 60 | 75 | 95 | 135 | 43 | 60 | 75 | 95 | 135 |
| F, mm | 38 | 50 | 57 | 75 | 120 | 38 | 50 | 57 | 75 | 120 |
| H, mm | 16 | 17 | 19 | 19 | 26 | 16 | 19 | 19 | 19 | 22 |
| M, mm | - | - | - | - | 148 | - | - | - | - | 85 |
| Q, mm | - | - | - | - | - | 28 | 38 | 48 | - | - |
| R, mm | 54 | 54 | 54 | 54 | 54 | 54 | 54 | 54 | 54 | 54 |
| S, mm | - | - | - | - | 25 | - | - | - | - | 55 |
| Z, ° | 10 | 10 | 5 | 5 | - | 10 | 5 | 5 | 5 | 5 |

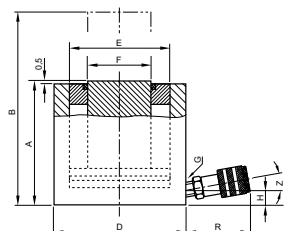

YLS

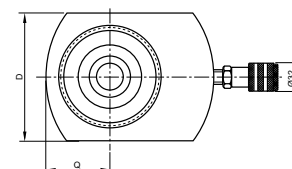
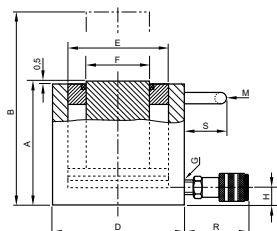

YFS

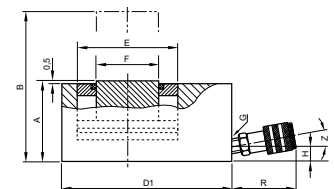



YPL

Pull cylinder

Single-acting with spring return,
capacity max. 10 - 51 t

Pull cylinders are able to produce extremely high pulling forces and can be controlled precisely by the use of hand pumps or power packs. In neutral position pull cylinders are fully extended. As soon as the cylinders are pressurized the forged links are drawn together. A built-in return spring extends the piston again as soon as the pressure is released.

Shipbuilding, heavy-vessel construction, steel construction, civil engineering as well as general repair and maintenance applications.

Features

- Yale ChroMo-Design.
- Operating pressure max. 700 bar.
- Single-acting with spring return.
- Can be operated in all positions (except model YPPS).
- Cylinder body and piston are made from solid chromium-molybdenum steel and heat-treated.
- Hard-chromium plated piston with replaceable, heat-treated saddle.
- Stop ring can bear full capacity (pressure) and is fitted with dirt wiper.
- Forged, replaceable links.
- With carrying handle and piston protection cover.
- Oil port thread 3/8 NPT.
- Incl. female coupler half model CFY-1.
- The pull cylinder YPPS-10/150 is equipped with an integrated hand pump similar to HPS-2/0,7 A.

INFO

Selection charts "cylinder/hand pumps" can be found on pages 416-417.

Travel-speed charts are supplied on pages 418-419.

Technical data YPL

| Cylinder size t | Model | Art.-No. | Capacity max. kN | Stroke mm | Effective plunger area cm ² | Oil volume max. cm ³ | Length between links mm | Weight kg |
|--------------------|-------------|-----------|---------------------|--------------|---|------------------------------------|----------------------------|--------------|
| 10 | YPL-10/150 | N11900349 | 100 | 150 | 14.2 | 213 | 750 | 9 |
| 20 | YPL-20/150 | N11900350 | 200 | 150 | 30.6 | 459 | 795 | 22 |
| 30 | YPL-30/150 | N11900351 | 300 | 150 | 42.6 | 639 | 875 | 29 |
| 51 | YPL-51/150 | N11900927 | 510 | 150 | 74.6 | 1120 | 955 | 59 |
| 10 | YPPS-10/150 | N11900001 | 100 | 150 | 14.2 | 213 | 750 | 19 |

Dimensions YPL

| Model | YPL-10/150 | YPL-20/150 | YPL-30/150 | YPL-51/150 | YPPS-10/150 |
|-------|------------|------------|------------|------------|-------------|
| A, mm | 749 | 795 | 875 | 955 | 749 |
| B, mm | 78 | 95 | 120 | 150 | 78 |
| C, mm | 32 | 35 | 56 | 70 | 32 |
| D, mm | 68 | 105 | 121 | 156 | 68 |
| E, mm | 120 | 120 | 150 | 150 | 120 |
| G, mm | 23 | 30 | 32 | 40 | 23 |
| H, mm | M24 x 1.5 | M45 x 2 | M50 x 2 | M60 x 2 | M24 x 1.5 |

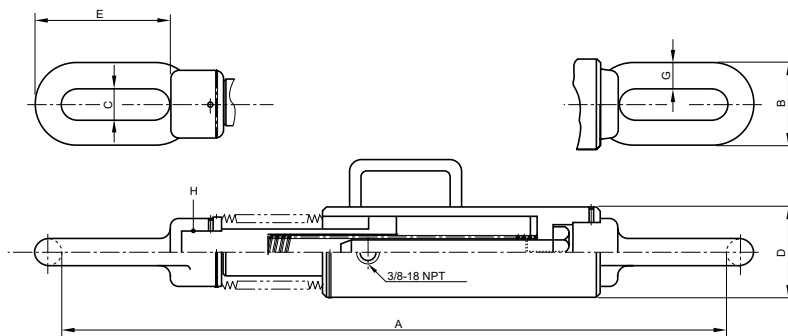



INFO

Selection charts "cylinder/hand pumps" can be found on pages 416-417.

Travel-speed charts are supplied on pages 418-419.



YCS

Hollow cylinders

Single-acting with spring return,
capacity 12 - 93 t

Due to the centre hole design a threaded rod can be placed through the hollow cylinders so that extremely high pulling forces can be achieved.

Hollow cylinders are used as the power component within hydraulic puller sets, for prestressing anker bolts, removing axles, shafts, bushings, extracting tubes, as well as for heavy-duty pulling applications.

Features

- Yale ChroMo-Design.
- Operating pressure max. 700 bar.
- Single-acting with spring return.
- With large centre hole diameter.
- Cylinder body and piston are made from solid chromium-molybdenum steel and heat-treated.
- Hard-chromium plated piston with replaceable, heat-treated saddle.
- Metric mounting threads at cylinder body and inside of piston.
- Stop ring prevents overtravel of the piston up to full operating pressure.
- Interchangeable hardened saddle.
- With inner and outer dirt wipers.
- Oil port thread 3/8 NPT.
- Incl. female coupler half model CFY-1.
- From model YCS-21/150 with carrying handle.
- From model YCS-57/70 with two lifting rings.

Function principal of the hollow cylinders

In connection with threaded rods hollow cylinders can produce extremely high forces which are helpful for various repair or assembly applications like removing press-fitted parts, prestressing anchors etc.

In addition, hollow cylinders are used as power source in puller sets and test rigs. By the use of long threaded rods and by readjusting the nut larger distances can be pulled even when using short cylinder strokes.

Technical data YCS

| Cylinder size | Model | Art.-No. | Capacity | Stroke | Effective plunger area | Oil volume max. | Closed height | Centre hole diameter | Cylinder outside diameter | Weight |
|---------------|------------|-----------|----------|--------|------------------------|-----------------|---------------|----------------------|---------------------------|--------|
| t | | | kN | mm | cm ² | cm ³ | mm | mm | mm | kg |
| 12 | YCS-12/40 | N11400070 | 120 | 40 | 17.2 | 71 | 142 | 20 | 70 | 3.5 |
| 12 | YCS-12/75 | N11400071 | 120 | 75 | 17.2 | 132 | 195 | 20 | 70 | 4.5 |
| 21 | YCS-21/50 | N11400072 | 214 | 50 | 30.5 | 153 | 173 | 27 | 100 | 8.5 |
| 21 | YCS-21/150 | N11400073 | 214 | 150 | 30.5 | 458 | 335 | 27 | 100 | 15.0 |
| 33 | YCS-33/60 | N11400074 | 335 | 60 | 47.9 | 287 | 193 | 33 | 114 | 12.0 |
| 33 | YCS-33/150 | N11400075 | 335 | 150 | 47.9 | 716 | 343 | 33 | 114 | 21.0 |
| 57 | YCS-57/70 | N11400076 | 567 | 70 | 81.0 | 562 | 242 | 42 | 150 | 25.0 |
| 62 | YCS-62/150 | N11400077 | 618 | 150 | 88.3 | 1330 | 335 | 55 | 163 | 38.0 |
| 93 | YCS-93/75 | N11400078 | 930 | 75 | 133 | 990 | 280 | 80 | 214 | 55.0 |

Dimensions YCS

| Model | YCS-12/40 | YCS-12/75 | YCS-21/50 | YCS-21/150 | YCS-33/60 | YCS-33/150 | YCS-57/70 | YCS-62/150 | YCS-93/75 |
|-------|-----------|-----------|-----------|------------|-----------|------------|-----------|------------|-----------|
| A, mm | 135 | 188 | 163 | 325 | 183 | 333 | 230 | 323 | 265 |
| B, mm | 175 | 263 | 213 | 475 | 243 | 483 | 300 | 473 | 340 |
| C, mm | 20 | 20 | 27 | 27 | 33 | 33 | 42 | 55 | 80 |
| D, mm | 70 | 70 | 100 | 100 | 114 | 114 | 150 | 163 | 214 |
| E, mm | 55 | 55 | 73 | 73 | 90 | 90 | 118 | 130 | 170 |
| F, mm | 40 | 40 | 53 | 53 | 65 | 65 | 90 | 100 | 136 |
| J, mm | 38 | 38 | 50 | 50 | 62 | 62 | 85 | 96 | 132 |
| K, mm | 3 | 3 | 3 | 3 | 3 | 3 | 3 | 3 | 5 |
| M, mm | - | - | - | 120 | - | 120 | - | - | - |
| O, mm | M30 x 1.5 | M30 x 1.5 | M40 x 1.5 | M40 x 1.5 | M48 x 1.5 | M48 x 1.5 | M65 x 2 | M78 x 2 | M115 x 2 |
| P, mm | 20 | 20 | 25 | 25 | 30 | 30 | 35 | 40 | 45 |
| R, mm | 4 | 4 | 5 | 5 | 5 | 5 | 5 | 5 | - |
| S, mm | - | - | - | 51 | - | 51 | 24 | 24 | 24 |
| T, mm | - | - | - | - | - | - | 155 | 200 | 170 |
| U, mm | 58 | 58 | 82 | 82 | 92 | 92 | 120 | 135 | 180 |
| V, mm | 2 x M8 | 2 x M8 | 2 x M10 | 2 x M10 | 4 x M10 | 4 x M10 | 4 x M12 | 4 x M12 | 4 x M16 |
| W, mm | 30 | 30 | 35 | 35 | 40 | 40 | 50 | 60 | - |
| X, mm | M70 x 2 | M70 x 2 | M100 x 2 | M100 x 2 | M110 x 2 | M110 x 2 | M150 x 3 | M160 x 3 | - |
| Y, mm | 7 | 7 | 10 | 10 | 10 | 10 | 12 | 12 | 15 |

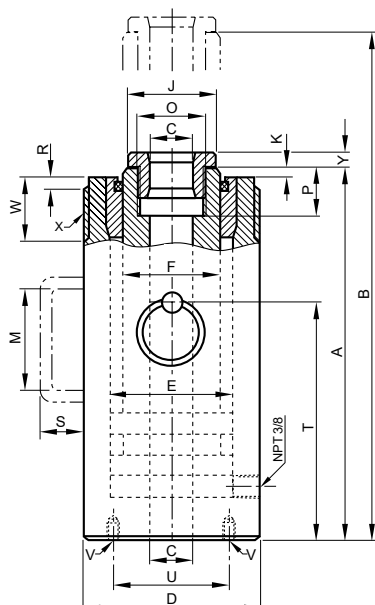



YCH Hollow cylinders

Double-acting with hydraulic return, capacity 33 - 140 t

Basically, the applications are the same as for the single-acting hollow cylinders shown on the opposite page, but for this model range the return of the piston is done hydraulically by means of the second oil port. These double-acting hollow cylinders are used when the piston needs to be retracted quickly e.g. with high-cycle pulling applications.

Features

- Yale ChroMo-Design.
- Operating pressure max. 700 bar.
- Double-acting with hydraulic return.
- With large centre hole diameter.
- Cylinder body and piston are made from solid chromium-molybdenum steel and heat-treated.
- Hard-chromium plated piston with replaceable, heat-treated saddle.
- Metric mounting threads at cylinder body and inside of piston.
- Stop ring prevents overtravel of the piston up to full operating pressure.
- Interchangeable hardened saddle.
- With inner and outer dirt wipers.
- Oil port thread 3/8 NPT.
- Incl. 2 female coupler halves model CFY-1.
- All cylinders with carrying handle, from model YCH-62/250 with 2 lifting rings.



INFO

Sonderanfertigungen bis zu einer Zugkraft von 600 t liefern wir auf Anfrage.

On request we supply special hollow cylinders with pulling capacities up to 600 tons.

Selection charts "cylinder/hand pumps" can be found on pages 416-417.

Travel-speed charts are supplied on pages 418-419.

Technical data YCH

| Cylinder size | Model | Art.-No. | Capacity push | Capacity pull | Stroke | Effective plunger area | Oil volume max. | Closed height | Centre hole diameter | Cylinder outside diameter | Weight |
|---------------|-------------|-----------|---------------|---------------|--------|------------------------|-----------------|---------------|----------------------|---------------------------|--------|
| t | | | kN | kN | mm | cm ² | cm ³ | mm | mm | mm | kg |
| 33 | YCH-33/150 | N11400079 | 335 | 180 | 150 | 47.9 | 716 | 310 | 33 | 114 | 19 |
| 33 | YCH-33/250 | N11400080 | 335 | 180 | 250 | 47.9 | 1200 | 415 | 33 | 114 | 25 |
| 62 | YCH-62/250 | N11400081 | 618 | 300 | 250 | 88.3 | 2220 | 452 | 55 | 163 | 55 |
| 93 | YCH-93/250 | N11400082 | 930 | 450 | 250 | 133.0 | 3320 | 465 | 55 | 193 | 82 |
| 100 | YCH-100/40 | N11400083 | 1000 | 500 | 40 | 143.0 | 578 | 190 | 55 | 200 | 38 |
| 140 | YCH-140/200 | N11400084 | 1400 | 700 | 200 | 200.2 | 4080 | 383 | 80 | 253 | 115 |

For double-acting hollow cylinders the "capacity push" is equivalent to the max. pulling force achieved with tensioning anchor or threaded spindle.

Dimensions YCH

| Model | YCH-33/150 | YCH-33/250 | YCH-62/250 | YCH-93/250 | YCH-100/40 | YCH-140/200 |
|-------|------------|------------|------------|------------|------------|-------------|
| A, mm | 300 | 405 | 440 | 450 | 175 | 365 |
| B, mm | 450 | 655 | 690 | 700 | 215 | 565 |
| C, mm | 33 | 33 | 55 | 55 | 55 | 80 |
| D, mm | 114 | 114 | 163 | 193 | 200 | 253 |
| E, mm | 90 | 90 | 130 | 150 | 155 | 195 |
| F, mm | 67 | 67 | 105 | 120 | 125 | 160 |
| J, mm | 62 | 62 | 96 | 110 | 110 | 145 |
| K, mm | 3 | 3 | 5 | 5 | 5 | 5 |
| M, mm | 120 | 120 | - | - | - | - |
| O, mm | M48 x 1.5 | M48 x 1.5 | M78 x 2 | M85 x 2 | M85 x 2 | M115 x 2 |
| P, mm | 30 | 30 | 40 | 45 | 45 | 50 |
| R, mm | 5 | 5 | 5 | 5 | - | - |
| S, mm | 51 | 51 | 24 | 30 | 24 | 30 |
| T, mm | - | - | 290 | 290 | 115 | 240 |
| U, mm | 92 | 92 | 135 | 160 | 165 | 210 |
| V, mm | 4 x M10 | 4 x M10 | 4 x M12 | 4 x M16 | 4 x M16 | 4 x M16 |
| W, mm | 40 | 40 | 50 | 65 | - | - |
| X, mm | M110 x 2 | M110 x 2 | M160 x 3 | M190 x 3 | - | - |
| Y, mm | 10 | 10 | 12 | 15 | 15 | 18 |

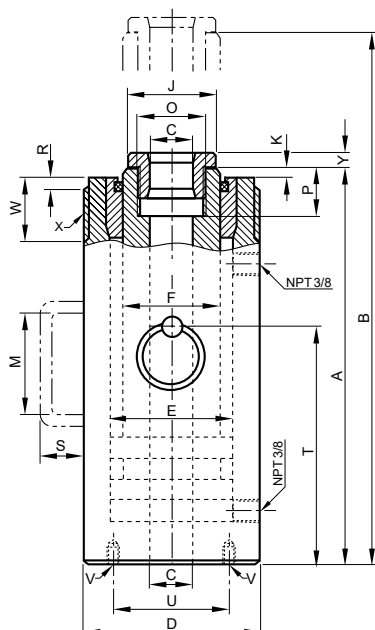



YH Universal cylinders

Double-acting with hydraulic return,
capacity 5 - 200 t

These extremely robust double-acting cylinders are especially designed for universal heavy-duty lifting and positioning applications as well as for industrial production and assembly jobs. The cylinders offer high pushing and pulling forces. The double-acting design assures a high piston retraction speed.

Major areas of application are bridge building and civil engineering, off-shore, ship building, etc. They can also be used as power source in frame presses, stamping fixtures and other industrial uses where high pushing and pulling forces are required.

Features

- Yale ChroMo-Design.
- Operating pressure max. 700 bar.
- Double-acting with hydraulic return.
- Long bronze piston guidings.
- Piston strokes from 30 up to 500 mm.
- Cylinder body and piston are made from solid chromium-molybdenum steel and heat-treated.
- Double bronze bearing of the hard chromium plated piston.
- Metric mounting threads on cylinder housing, in the bottom of the cylinder body and in the piston rod.
- Stop ring can bear full capacity (pressure) and is fitted with dirt wiper.
- Interchangeable hardened saddle.
- Dirt wiper protects against dirt.
- Oil port thread 3/8 NPT.
- Incl. 2 female coupler halves model CFY-1.
- From model YH-30/200 with carrying handle.
- From model YH-50/350 with 2 lifting rings.

INFO

For cylinders series YH accessories please see pages 358-359.

Selection charts "cylinder/hand pumps" can be found on pages 416-417.

Travel-speed charts are supplied on pages 418-419.

Technical data YH

| Cylinder size | Model | Art.-No. | Capacity push | Capacity pull | Stroke | Effective plunger area push | Effective plunger area pull | Oil volume max. | Closed height | Cylinder outside diameter | Weight |
|---------------|------------|-----------|---------------|---------------|--------|-----------------------------|-----------------------------|-----------------|---------------|---------------------------|--------|
| t | | | kN | kN | mm | cm ² | cm ² | cm ³ | mm | mm | kg |
| 5 | YH-5/30 | N11200038 | 50 | 22 | 30 | 7.2 | 3.1 | 21 | 160 | 55 | 2.5 |
| 5 | YH-5/80 | N11200039 | 50 | 22 | 80 | 7.2 | 3.1 | 57 | 210 | 55 | 3.3 |
| 5 | YH-5/150 | N11200040 | 50 | 22 | 150 | 7.2 | 3.1 | 106 | 280 | 55 | 4.4 |
| 10 | YH-10/30 | N11200041 | 100 | 45 | 30 | 14.3 | 6.4 | 44 | 175 | 67 | 4.0 |
| 10 | YH-10/80 | N11200042 | 100 | 45 | 80 | 14.3 | 6.4 | 116 | 225 | 67 | 5.0 |
| 10 | YH-10/150 | N11200043 | 100 | 45 | 150 | 14.3 | 6.4 | 218 | 295 | 67 | 6.7 |
| 10 | YH-10/250 | N11200044 | 100 | 45 | 250 | 14.3 | 6.4 | 363 | 395 | 67 | 9.0 |
| 20 | YH-20/50 | N11200045 | 200 | 100 | 50 | 28.6 | 14.3 | 142 | 195 | 85 | 7.0 |
| 20 | YH-20/150 | N11200046 | 200 | 100 | 150 | 28.6 | 14.3 | 424 | 310 | 85 | 11.0 |
| 20 | YH-20/250 | N11200047 | 200 | 100 | 250 | 28.6 | 14.3 | 707 | 410 | 85 | 14.0 |
| 30 | YH-30/200 | N11200048 | 300 | 140 | 200 | 42.9 | 20.0 | 884 | 355 | 102 | 19.0 |
| 30 | YH-30/350 | N11200049 | 300 | 140 | 350 | 42.9 | 20.0 | 1547 | 510 | 102 | 27.0 |
| 50 | YH-50/150 | N11200050 | 500 | 220 | 150 | 71.5 | 31.5 | 1064 | 325 | 125 | 27.0 |
| 50 | YH-50/350 | N11200051 | 500 | 220 | 350 | 71.5 | 31.5 | 2481 | 525 | 125 | 42.0 |
| 50 | YH-50/500 | N11200052 | 500 | 220 | 500 | 71.5 | 31.5 | 3544 | 685 | 125 | 52.0 |
| 70 | YH-70/150 | N11200053 | 700 | 330 | 150 | 100.0 | 47.2 | 1478 | 335 | 146 | 37.0 |
| 70 | YH-70/350 | N11200054 | 700 | 330 | 350 | 100.0 | 47.2 | 3449 | 540 | 146 | 56.0 |
| 100 | YH-100/50 | N11200055 | 1000 | 450 | 50 | 143.0 | 64.4 | 716 | 265 | 180 | 49.0 |
| 100 | YH-100/150 | N11200056 | 1000 | 450 | 150 | 143.0 | 64.4 | 2148 | 365 | 180 | 64.0 |
| 100 | YH-100/350 | N11200057 | 1000 | 450 | 350 | 143.0 | 64.4 | 5010 | 565 | 180 | 94.0 |
| 100 | YH-100/500 | N11200058 | 1000 | 450 | 500 | 143.0 | 64.4 | 7157 | 725 | 180 | 118.0 |
| 200 | YH-200/150 | N11200059 | 2000 | 900 | 150 | 286.0 | 128.7 | 4253 | 410 | 250 | 137.0 |
| 200 | YH-200/350 | N11200060 | 2000 | 900 | 350 | 286.0 | 128.7 | 9924 | 620 | 250 | 198.0 |
| 200 | YH-200/500 | N11200061 | 2000 | 900 | 500 | 286.0 | 128.7 | 14177 | 780 | 250 | 244.0 |



Hydraulic Jacks & Tools Hydraulic cylinders, double-acting

Dimensions YH

| Model | YH-5/30 | YH-5/80 | YH-5/150 | YH-10/30 | YH-10/80 | YH-10/150 | YH-10/250 | YH-20/50 | YH-20/150 | YH-20/250 | YH-30/200 | YH-30/350 |
|-------|-----------|-----------|-----------|-----------|-----------|-----------|-----------|----------|-----------|-----------|-----------|-----------|
| A, mm | 160 | 210 | 280 | 175 | 225 | 295 | 395 | 195 | 310 | 410 | 355 | 510 |
| B, mm | 190 | 290 | 430 | 205 | 305 | 445 | 645 | 245 | 460 | 660 | 555 | 860 |
| C, mm | 138 | 188 | 258 | 150 | 200 | 270 | 370 | 167 | 282 | 382 | 345 | 500 |
| D, mm | 55 | 55 | 55 | 67 | 67 | 67 | 67 | 85 | 85 | 85 | 102 | 102 |
| E, mm | 30 | 30 | 30 | 43 | 43 | 43 | 43 | 60 | 60 | 60 | 75 | 75 |
| F, mm | 22.4 | 22.4 | 22.4 | 32 | 32 | 32 | 32 | 42 | 42 | 42 | 55 | 55 |
| H, mm | 31 | 31 | 31 | 35 | 35 | 35 | 35 | 22 | 37 | 37 | 46 | 46 |
| I, mm | 44 | 44 | 44 | 50 | 50 | 50 | 50 | 59 | 59 | 59 | 64 | 64 |
| J, mm | - | - | - | - | - | - | - | - | - | - | 50 | 50 |
| K, mm | 4 | 4 | 4 | 5 | 5 | 5 | 5 | 5 | 5 | 5 | 10 | 10 |
| L, mm | 17 | 17 | 17 | 20 | 20 | 20 | 20 | - | 22 | 22 | 28 | 28 |
| O, mm | M18 x 1.5 | M18 x 1.5 | M18 x 1.5 | M27 x 2 | M27 x 2 | M27 x 2 | M27 x 2 | M36 x 2 | M36 x 2 | M36 x 2 | M36 x 2 | M36 x 2 |
| P, mm | 18 | 18 | 18 | 20 | 20 | 20 | 20 | 23 | 23 | 23 | 28 | 28 |
| S, mm | - | - | - | - | - | - | - | - | - | - | 51 | 51 |
| U, mm | - | - | - | - | - | - | - | - | - | - | - | - |
| V, mm | M27 x 2 | M27 x 2 | M27 x 2 | M36 x 2 | M36 x 2 | M36 x 2 | M36 x 2 | - | M45 x 2 | M45 x 2 | M36 x 2 | M36 x 2 |
| W, mm | 27 | 27 | 27 | 33 | 33 | 33 | 33 | 40 | 40 | 40 | 45 | 45 |
| X, mm | M55 x 1.5 | M55 x 1.5 | M55 x 1.5 | M67 x 1.5 | M67 x 1.5 | M67 x 1.5 | M67 x 1.5 | M85 x 2 | M85 x 2 | M85 x 2 | M102 x 2 | M102 x 2 |

| Model | YH-50/150 | YH-50/350 | YH-50/500 | YH-70/150 | YH-70/350 | YH-100/50 | YH-100/150 | YH-100/350 | YH-100/500 | YH-200/150 | YH-200/350 | YH-200/500 |
|-------|-----------|-----------|-----------|-----------|-----------|-----------|------------|------------|------------|------------|------------|------------|
| A, mm | 325 | 525 | 685 | 335 | 540 | 265 | 365 | 565 | 725 | 410 | 620 | 780 |
| B, mm | 475 | 875 | 1185 | 485 | 890 | 315 | 515 | 915 | 1225 | 560 | 970 | 1280 |
| C, mm | 313 | 513 | 673 | 321 | 526 | 250 | 350 | 550 | 710 | 391 | 601 | 761 |
| D, mm | 125 | 125 | 125 | 146 | 146 | 180 | 180 | 180 | 180 | 250 | 250 | 250 |
| E, mm | 95 | 95 | 95 | 112 | 112 | 135 | 135 | 135 | 135 | 190 | 190 | 190 |
| F, mm | 70 | 70 | 70 | 80 | 80 | 100 | 100 | 100 | 100 | 140 | 140 | 140 |
| H, mm | 55 | 55 | 55 | 58 | 58 | 66 | 66 | 66 | 66 | 80 | 80 | 80 |
| I, mm | 70 | 70 | 70 | 79 | 79 | 90 | 90 | 90 | 95 | 105 | 105 | 105 |
| J, mm | 65 | 65 | 65 | 75 | 75 | 90 | 90 | 90 | 90 | 127 | 127 | 127 |
| K, mm | 12 | 12 | 12 | 14 | 14 | 15 | 15 | 15 | 15 | 19 | 19 | 19 |
| L, mm | 31 | 31 | 31 | 35 | 35 | - | - | - | - | - | - | - |
| O, mm | M45 x 2 | M45 x 2 | M45 x 2 | M50 x 3 | M50 x 3 | M65 x 3 | M65 x 3 | M65 x 3 | M65 x 3 | M90 x 3 | M90 x 3 | M90 x 3 |
| P, mm | 31 | 31 | 31 | 35 | 35 | 40 | 40 | 40 | 40 | 55 | 55 | 55 |
| S, mm | 51 | 24 | 24 | 24 | 24 | 24 | 24 | 30 | 30 | 30 | 30 | 30 |
| U, mm | - | - | - | - | - | 110 | 110 | 110 | 110 | 160 | 160 | 160 |
| V, mm | M45 x 2 | M45 x 2 | M45 x 2 | M50 x 3 | M50 x 3 | 4 x M12 | 4 x M12 | 4 x M12 | 4 x M12 | 4 x M16 | 4 x M16 | 4 x M16 |
| W, mm | 50 | 50 | 50 | 60 | 60 | 70 | 70 | 70 | 70 | 80 | 80 | 80 |
| X, mm | M125 x 2 | M125 x 2 | M125 x 2 | M146 x 3 | M146 x 3 | M180 x 3 | M180 x 3 | M180 x 3 | M180 x 3 | M250 x 4 | M250 x 4 | M250 x 4 |

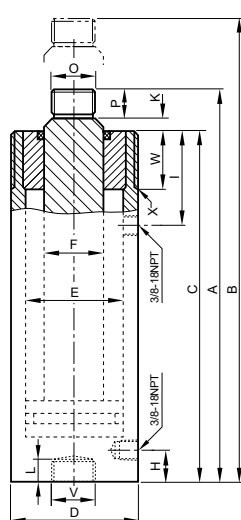

YH-5/30 up to YH 20/250

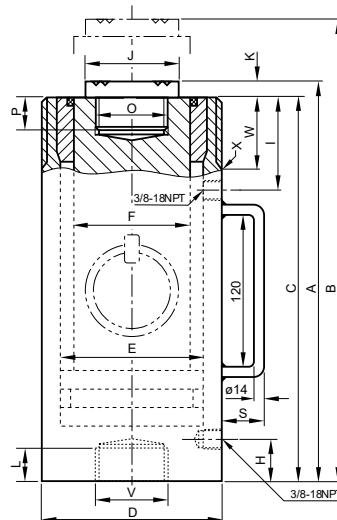

YH-30/200 up to YH 70/350

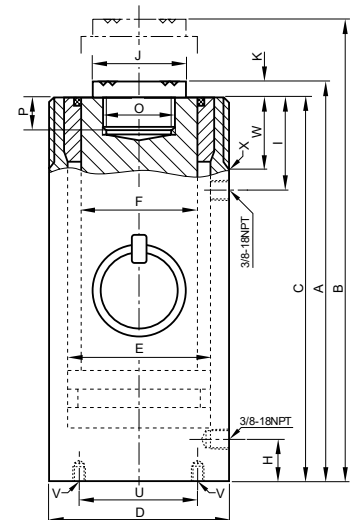

YH-100/50 up to YH 200/500





YEHB

High-tonnage cylinders

Double-acting with hydraulic return,
capacity max. 140 - 1100t

Cylinders of series YEHB are normally used for lifting, positioning or handling heavy loads. The double-acting function allows a faster piston return, even with longer hydraulic hoses.

Lifting and moving of large machinery, steel construction, bridges or similar loads, supporting of buildings and foundations.

Further applications are positioning, weighing, through pressing, stress testing or jacking of all kinds of loads.

Features

- Operating pressure max. 700 bar.
- Double-acting with hydraulic return.
- Generous guiding bands ensure a robust piston guiding.
- Hard chromium-plated piston.
- Stop ring as piston end stop.
- Interchangeable hardened saddle.
- Dirt wiper protects against dirt.
- Oil port thread 3/8 NPT.
- Incl. 2 female coupler halves model CFY-1.
- Mounting threads on request.
- All cylinders have lifting rings.



INFO

Selection charts "cylinder/hand pumps" can be found on pages 416-417.

Travel-speed charts are supplied on pages 418-419.

Technical data YEHB

| Cylinder size t | Model | Art.-No | Capacity max kN | Stroke mm | Effective plunger area cm ² | Oil volume max cm ³ | Closed height mm | Cylinder outside diameter mm | Weight kg |
|--------------------|---------------|---------|--------------------|--------------|---|-----------------------------------|---------------------|---------------------------------|--------------|
| 140 | YEHB-140/50 | - | 1407 | 50 | 201 | 1005 | 213 | 210 | 53 |
| 140 | YEHB-140/150 | - | 1407 | 150 | 201 | 3016 | 318 | 210 | 74 |
| 140 | YEHB-140/300 | - | 1407 | 300 | 201 | 6032 | 478 | 210 | 104 |
| 220 | YEHB-220/50 | - | 2199 | 50 | 314 | 1571 | 233 | 260 | 90 |
| 220 | YEHB-220/150 | - | 2199 | 150 | 314 | 4712 | 333 | 260 | 120 |
| 220 | YEHB-220/300 | - | 2199 | 300 | 314 | 9425 | 498 | 260 | 169 |
| 310 | YEHB-310/50 | - | 3036 | 50 | 434 | 2169 | 251 | 305 | 137 |
| 310 | YEHB-310/150 | - | 3036 | 150 | 434 | 6506 | 357 | 305 | 189 |
| 310 | YEHB-310/300 | - | 3036 | 300 | 434 | 13012 | 512 | 305 | 263 |
| 410 | YEHB-410/50 | - | 4008 | 50 | 573 | 2863 | 275 | 350 | 197 |
| 410 | YEHB-410/150 | - | 4008 | 150 | 573 | 8588 | 382 | 350 | 262 |
| 410 | YEHB-410/300 | - | 4008 | 300 | 573 | 17177 | 538 | 350 | 357 |
| 520 | YEHB-520/50 | - | 5114 | 50 | 731 | 3653 | 305 | 400 | 197 |
| 520 | YEHB-520/150 | - | 5114 | 150 | 731 | 10959 | 410 | 400 | 262 |
| 520 | YEHB-520/300 | - | 5114 | 300 | 731 | 21918 | 566 | 400 | 357 |
| 610 | YEHB-610/50 | - | 5987 | 50 | 855 | 4276 | 315 | 430 | 342 |
| 610 | YEHB-610/150 | - | 5987 | 150 | 855 | 12829 | 420 | 430 | 440 |
| 610 | YEHB-610/300 | - | 5987 | 300 | 855 | 25659 | 576 | 430 | 583 |
| 830 | YEHB-830/50 | - | 8149 | 50 | 1164 | 5821 | 335 | 505 | 504 |
| 830 | YEHB-830/150 | - | 8149 | 150 | 1164 | 17462 | 446 | 505 | 649 |
| 830 | YEHB-830/300 | - | 8149 | 300 | 1164 | 34925 | 606 | 505 | 858 |
| 1100 | YEHB-1100/50 | - | 10644 | 50 | 1521 | 7603 | 365 | 570 | 696 |
| 1100 | YEHB-1100/150 | - | 10644 | 150 | 1521 | 22808 | 476 | 570 | 869 |
| 1100 | YEHB-1100/300 | - | 10644 | 300 | 1521 | 45616 | 636 | 570 | 1116 |



INFO

For tilt saddles for cylinders please see pages 354-355.



YELB Hydraulic cylinders with safety lock nut

Single-acting, gravity return
capacity max. 30 - 1100t

Hydraulic cylinders with safety lock nut are recommended when loads have to remain in the lifted position over a period of time. The safety lock nut ensures a positive load hold in any position, and work can be carried out beneath the lifted load. Hydraulic pressure can be released so that cylinders work like mechanical supports. Pumps can be separated from cylinders.

Lifting and moving of large machinery, steel construction, bridges or similar loads, supporting of buildings and foundations.

For all heavy-duty jacking applications where a special safety factor is appropriate like lifting and lowering bridges, supporting buildings and foundations, jacking up heavy machines, steel sections, ship modules or similar loads.

Features

- Operating pressure max. 700 bar.
- Single-acting, gravity return.
- Generous guiding bands ensure a robust piston guiding.
- Hard chromium-plated piston with trapezoidal thread.
- Overflow hole ensures a definite piston end stop.
- Interchangeable hardened saddle.
- Oil port thread 3/8 NPT.
- Incl. female coupler half model CFY-1.
- All cylinders have lifting rings.

INFO

Further piston strokes are quoted on request.

For tilt saddles for cylinders please see pages 354 - 355.



Technical data YELB

| Cylinder size | Model | Art.-No. | Capacity max. | Stroke | Effective plunger area | Oil volume max. | Closed height | Cylinder outside diameter | Weight |
|---------------|---------------|----------|---------------|--------|------------------------|-----------------|---------------|---------------------------|--------|
| t | | | kN | mm | cm ² | cm ³ | mm | mm | kg |
| 30 | YELB-30/50 | - | 303 | 50 | 44 | 221 | 141 | 100 | 9 |
| 30 | YELB-30/100 | - | 303 | 100 | 44 | 442 | 191 | 100 | 12 |
| 30 | YELB-30/150 | - | 303 | 150 | 44 | 663 | 246 | 100 | 15 |
| 30 | YELB-30/200 | - | 303 | 200 | 44 | 884 | 296 | 100 | 18 |
| 30 | YELB-30/300 | - | 303 | 300 | 44 | 1325 | 405 | 100 | 25 |
| 50 | YELB-50/50 | - | 496 | 50 | 71 | 354 | 153 | 125 | 14 |
| 50 | YELB-50/100 | - | 496 | 100 | 71 | 709 | 203 | 125 | 19 |
| 50 | YELB-50/150 | - | 496 | 150 | 71 | 1063 | 261 | 125 | 25 |
| 50 | YELB-50/200 | - | 496 | 200 | 71 | 1418 | 311 | 125 | 30 |
| 50 | YELB-50/300 | - | 496 | 300 | 71 | 2126 | 416 | 125 | 40 |
| 100 | YELB-93/50 | - | 929 | 50 | 133 | 664 | 180 | 170 | 31 |
| 100 | YELB-93/100 | - | 929 | 100 | 133 | 1327 | 230 | 170 | 40 |
| 100 | YELB-93/150 | - | 929 | 150 | 133 | 1991 | 285 | 170 | 50 |
| 100 | YELB-93/200 | - | 929 | 200 | 133 | 2655 | 335 | 170 | 59 |
| 100 | YELB-93/300 | - | 929 | 300 | 133 | 3982 | 441 | 170 | 78 |
| 140 | YELB-140/50 | - | 1407 | 50 | 201 | 1005 | 195 | 210 | 52 |
| 140 | YELB-140/100 | - | 1407 | 100 | 201 | 2011 | 245 | 210 | 65 |
| 140 | YELB-140/150 | - | 1407 | 150 | 201 | 3016 | 309 | 210 | 83 |
| 140 | YELB-140/200 | - | 1407 | 200 | 201 | 4021 | 359 | 210 | 96 |
| 140 | YELB-140/300 | - | 1407 | 300 | 201 | 6032 | 465 | 210 | 125 |
| 220 | YELB-220/150 | - | 2192 | 150 | 314 | 4712 | 328 | 260 | 134 |
| 220 | YELB-220/300 | - | 2192 | 300 | 314 | 9425 | 488 | 260 | 201 |
| 310 | YELB-310/150 | - | 3037 | 150 | 434 | 6506 | 351 | 305 | 197 |
| 310 | YELB-310/300 | - | 3037 | 300 | 434 | 13012 | 511 | 305 | 289 |
| 410 | YELB-410/150 | - | 4008 | 150 | 573 | 8588 | 370 | 350 | 274 |
| 410 | YELB-410/300 | - | 4008 | 300 | 573 | 17177 | 530 | 350 | 395 |
| 520 | YELB-520/150 | - | 5114 | 150 | 731 | 10959 | 395 | 400 | 378 |
| 520 | YELB-520/300 | - | 5114 | 300 | 731 | 21918 | 555 | 400 | 535 |
| 610 | YELB-610/50 | - | 5987 | 50 | 855 | 4276 | 311 | 430 | 347 |
| 610 | YELB-610/150 | - | 5987 | 150 | 855 | 12829 | 421 | 430 | 472 |
| 610 | YELB-610/300 | - | 5987 | 300 | 855 | 25659 | 581 | 430 | 654 |
| 830 | YELB-830/50 | - | 8149 | 50 | 1164 | 5821 | 348 | 505 | 537 |
| 830 | YELB-830/150 | - | 8149 | 150 | 1164 | 17462 | 458 | 505 | 709 |
| 830 | YELB-830/300 | - | 8149 | 300 | 1164 | 34925 | 618 | 505 | 959 |
| 1085 | YELB-1100/50 | - | 10644 | 50 | 1520 | 7603 | 392 | 570 | 772 |
| 1085 | YELB-1100/150 | - | 10644 | 150 | 1520 | 22808 | 502 | 570 | 991 |
| 1085 | YELB-1100/300 | - | 10644 | 300 | 1520 | 45616 | 673 | 570 | 1332 |

INFO

Selection charts "cylinder/hand pumps" can be found on pages 416-417.

Travel-speed charts are supplied on pages 418-419.



INFO

Further piston strokes are quoted on request.

The use of tilt saddles is recommended.

Selection charts "cylinder/hand pumps" can be found on pages 416-417.

Travel-speed charts are supplied on pages 418-419.

YEGB

High-tonnage cylinders

Single-acting, gravity return
capacity max. 140 - 1100t

These inexpensive cylinders of series YEGB are used for all general lifting applications in any area of industry where heavy loads need to be lifted, lowered, levelled, positioned or supported.

Lifting and moving large machinery, steel construction, bridges or similar loads, supporting buildings and foundations.

For all heavy-duty jacking applications where a special safety factor is appropriate like lifting and lowering bridges, supporting buildings and foundations, jacking up heavy machines, steel sections, ship modules or similar loads.

Features

- Operating pressure max. 700 bar.
- Plunger in special piston guiding bands.
- Hard chromium-plated piston.
- Overflow hole ensures a definite piston end stop.
- Interchangeable hardened saddle.
- Oil port thread 3/8 NPT.
- Incl. female coupler half model CFY-1.
- All cylinders have lifting rings.



INFO

Available for all cylinder series YELB, YEGB and YEHB.

AYB

Tilt saddles for cylinders

Tilt saddles should be used with YELB and YEGB cylinders in cases where cylinders are operated on non-parallel surfaces.

The saddles minimize inner friction caused by eccentric loading of the cylinders. The upper part of the saddle can pivot up to 5° in all directions. Tilt saddles are fixed in the piston by means of an O-ring.

Technical data YEGB

| Cylinder size t | Model | Art.-No. | Capacity max. kN | Stroke mm | Effective plunger area cm ³ | Oil volume max. cm ³ | Closed height mm | Cylinder outside diameter mm | Weight kg |
|--------------------|---------------|----------|---------------------|--------------|---|------------------------------------|---------------------|---------------------------------|--------------|
| 140 | YEGB-140/50 | – | 1407 | 50 | 201 | 1005 | 160 | 210 | 43 |
| 140 | YEGB-140/150 | – | 1407 | 150 | 201 | 3016 | 274 | 210 | 74 |
| 140 | YEGB-140/300 | – | 1407 | 300 | 201 | 6032 | 430 | 210 | 116 |
| 220 | YEGB-220/50 | – | 2200 | 50 | 314 | 1571 | 180 | 260 | 75 |
| 220 | YEGB-220/150 | – | 2200 | 150 | 314 | 4712 | 291 | 260 | 120 |
| 220 | YEGB-220/300 | – | 2200 | 300 | 314 | 9425 | 451 | 260 | 187 |
| 310 | YEGB-310/50 | – | 3036 | 50 | 434 | 2169 | 193 | 305 | 110 |
| 310 | YEGB-310/150 | – | 3036 | 150 | 434 | 6506 | 309 | 305 | 176 |
| 310 | YEGB-310/300 | – | 3036 | 300 | 434 | 13012 | 469 | 305 | 267 |
| 410 | YEGB-410/50 | – | 4008 | 50 | 573 | 2863 | 215 | 350 | 161 |
| 410 | YEGB-410/150 | – | 4008 | 150 | 573 | 8588 | 325 | 350 | 244 |
| 410 | YEGB-410/300 | – | 4008 | 300 | 573 | 17177 | 485 | 350 | 364 |
| 520 | YEGB-520/50 | – | 5114 | 50 | 731 | 3653 | 225 | 400 | 221 |
| 520 | YEGB-520/150 | – | 5114 | 150 | 731 | 10959 | 335 | 400 | 329 |
| 520 | YEGB-520/300 | – | 5114 | 300 | 731 | 21918 | 495 | 400 | 486 |
| 610 | YEGB-610/50 | – | 5987 | 50 | 855 | 4276 | 236 | 430 | 268 |
| 610 | YEGB-610/150 | – | 5987 | 150 | 855 | 12829 | 346 | 430 | 393 |
| 610 | YEGB-610/300 | – | 5987 | 300 | 855 | 25659 | 506 | 430 | 574 |
| 830 | YEGB-830/50 | – | 8149 | 50 | 1164 | 5821 | 263 | 505 | 411 |
| 830 | YEGB-830/150 | – | 8149 | 150 | 1164 | 17462 | 373 | 505 | 583 |
| 830 | YEGB-830/300 | – | 8149 | 300 | 1164 | 34925 | 533 | 505 | 834 |
| 1085 | YEGB-1100/50 | – | 10644 | 50 | 1521 | 7603 | 292 | 570 | 582 |
| 1085 | YEGB-1100/150 | – | 10644 | 150 | 1521 | 22808 | 402 | 570 | 801 |
| 1085 | YEGB-1100/300 | – | 10644 | 300 | 1521 | 45616 | 573 | 570 | 1142 |

Technical data AYB

| Model | Art.-No. | Suitable for cylinder groups | Weight kg |
|---------|----------|------------------------------|--------------|
| AYB-50 | – | YELB-30 and YELB-50 | 0.4 |
| AYB-93 | – | YELB-93 | 0.8 |
| AYB-140 | – | YELB-140, YEGB-140, YEHB-140 | 2.0 |
| AYB-220 | – | YELB-220, YEGB-220, YEHB-220 | 3.4 |
| AYB-310 | – | YELB-310, YEGB-310, YEHB-310 | 13.0 |
| AYB-410 | – | YELB-410, YEGB-410, YEHB-410 | on request |
| AYB-520 | – | YELB-520, YEGB-520, YEHB-520 | on request |

Other sizes on request

Dimensions AYB

| Model | AYB-50 | AYB-93 | AYB-140 | AYB-220 | AYB-310 | AYB-410 | AYB-520 |
|-------|--------|--------|---------|---------|---------|---------|---------|
| L, mm | 50 | 71.5 | 94 | 113 | 139 | 159 | 179 |
| N, mm | 34 | 30 | 39.2 | 43 | 68.5 | 78 | 77 |
| O, mm | 71 | 71 | 97 | 126 | 175 | 210 | 230 |

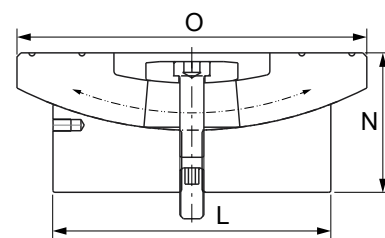



AYS

Lifting claws, piston plates, base adaptors and extension tubes, load-spreading plates

Lifting claws

In connection with the corresponding hydraulic cylinder a lifting claw represents a compact, lightweight and versatile lifting unit. The lifting claws are screwed onto the collar thread of cylinder series YS. Claws can be placed under loads with minimum clearance.

When operating lifting claws, the following aspects have to be considered:

The hydraulic cylinders need to be able to support themselves against the load. The max. force of the cylinder is reduced by 50%.

Piston plates

Piston plates can be screwed into the piston thread of cylinder series YS. They reduce the surface pressure and prevent the pistons from sinking into the ground. Also when using a piston plate in connection with a lifting claw the cylinder must be supported against the load.

Base adaptors and extension tubes

Extension tubes are mounted onto the bottom of cylinders series YS by means of the base adaptor and two hexagon socket screws (screws are included with the base adaptor). The use of extension tubes adds to the versatility of the standard cylinders.

Load-spreading plates

These load-spreading plates are recommended when slim cylinders are used for lifting operations. They prevent the cylinders from falling over and sinking into the ground. Robust steel design with carrying handle.



AYS-101
151
231



Straightening of a container box by use of a hydraulic cylinder YS-10/100, extension tube AYS-106, base adaptor AYS-103 and electric power pump PY-04/2/5/2 M.



Lifting of a container by use of an hydraulic cylinder YS-23/160, lifting claw AYS-23 and piston plate AYS-232 powered by a two-stage hand pump HPS-2/2 with base frame.

Technical data AYS

| Model | Art.-No. | Description | Suitable for cylinder | Weight kg |
|---------|-----------|---|-----------------------|-----------|
| AYS-10 | N14500303 | Lifting claw, permissible capacity 5 t | YS-10/... | 0.9 |
| AYS-15 | N14500304 | Lifting claw, permissible capacity 8 t | YS-15/... | 1.3 |
| AYS-23 | N14500311 | Lifting claw, permissible capacity 12 t | YS-23/... | 3.8 |
| AYS-53 | N14500672 | Base adaptor, 5 t | YS-5/... | 0.5 |
| AYS-54 | N14500673 | Extension tube 125 mm, 5 t | YS-5/... | 0.9 |
| AYS-55 | N14500674 | Extension tube 250 mm, 5 t | YS-5/... | 1.5 |
| AYS-56 | N14500675 | Extension tube 500 mm, 5 t | YS-5/... | 2.8 |
| AYS-101 | N14500678 | Load-spreading plate 10 t | YS-10/... | 10.5 |
| AYS-102 | N14500324 | Piston plate, round | YS-10/... | 1.5 |
| AYS-103 | N14500336 | Base adaptor, 10 t | YS-10/... | 0.7 |
| AYS-104 | N14500337 | Extension tube 125 mm, 10 t | YS-10/... | 1.2 |
| AYS-105 | N14500338 | Extension tube 250 mm, 10 t | YS-10/... | 2.2 |
| AYS-106 | N14500339 | Extension tube 500 mm, 10 t | YS-10/... | 3.9 |
| AYS-107 | N14500340 | Extension tube 750 mm, 10 t | YS-10/... | 5.9 |
| AYS-151 | N14500681 | Load-spreading plate 15 t | YS-15/... | 10.5 |
| AYS-152 | N14500325 | Piston plate, round | YS-15/... | 1.8 |
| AYS-153 | N14500506 | Base adaptor, 15 t | YS-15/... | 0.9 |
| AYS-154 | N14500507 | Extension tube 125 mm, 15 t | YS-15/... | 1.6 |
| AYS-155 | N14500508 | Extension tube 250 mm, 15 t | YS-15/... | 2.9 |
| AYS-156 | N14500509 | Extension tube 500 mm, 15 t | YS-15/... | 4.9 |
| AYS-157 | N14500510 | Extension tube 750 mm, 15 t | YS-15/... | 7.9 |
| AYS-231 | N14500684 | Load-spreading plate 23 t | YS-23/... | 10.5 |
| AYS-232 | N14500326 | Piston plate, round | YS-23/... | 2.2 |

Dimensions AYS

| Model | AYS-10 | AYS-15 | AYS-23 | AYS-53 | AYS-54 | AYS-55 | AYS-56 | AYS-101 | AYS-102 | AYS-103 | AYS-104 | AYS-105 |
|-------|-----------|-----------|---------|-----------|-----------|-----------|-----------|---------|---------|---------|---------|---------|
| A, mm | 90 | 110 | 125 | 53 | 125 | 250 | 500 | 230 | 140 | 58 | 125 | 250 |
| B, mm | 90 | 110 | 125 | 50 | - | - | - | 120 | 12 | 60 | - | - |
| C, mm | 30 | 30 | 30 | - | - | - | - | 58 | - | - | - | - |
| D, mm | 29 | 34 | 40 | - | - | - | - | - | - | - | - | - |
| E, mm | 22 | 25 | 35 | - | - | - | - | - | - | - | - | - |
| F, mm | M57 x 1.5 | M67 x 1.5 | M85 x 2 | M42 x 1.5 | M42 x 1.5 | M42 x 1.5 | M42 x 1.5 | - | M27 x 2 | M50 x 2 | M50 x 2 | M50 x 2 |

| Model | AYS-106 | AYS-107 | AYS-151 | AYS-152 | AYS-153 | AYS-154 | AYS-155 | AYS-156 | AYS-157 | AYS-231 | AYS-232 |
|-------|---------|---------|---------|---------|---------|---------|---------|---------|---------|---------|---------|
| A, mm | 500 | 750 | 230 | 140 | 70 | 125 | 250 | 500 | 750 | 230 | 160 |
| B, mm | - | - | 120 | 12 | 73 | - | - | - | - | 120 | 15 |
| C, mm | - | - | 68 | - | - | - | - | - | - | 86 | - |
| D, mm | - | - | - | - | - | - | - | - | - | - | - |
| E, mm | - | - | - | - | - | - | - | - | - | - | - |
| F, mm | M50 x 2 | M50 x 2 | - | M33 x 2 | M60 x 2 | M60 x 2 | M60 x 2 | M60 x 2 | M60 x 2 | - | M40 x 2 |

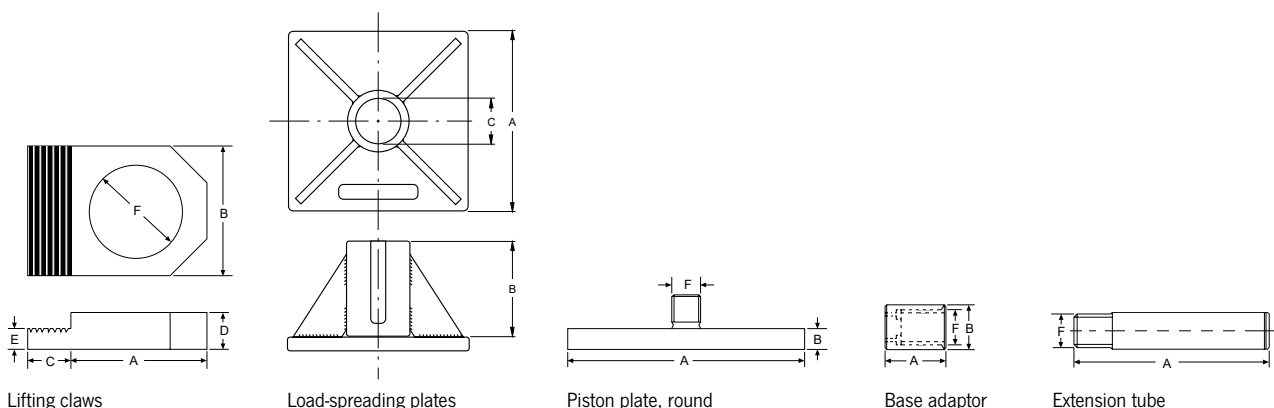



AYP

Threaded flanges

In case hydraulic cylinders have to be inserted into fixtures, press frames or similar devices, these steel flanges can be very handy. Material: weldable steel.

Technical data AYP

| Model | Art.-No. | Suitable for cylinder | Weight kg |
|-----------|-----------|---------------------------|-----------|
| AYP-1010 | N13700670 | YS-10/... | 9.7 |
| AYP-1510 | N13700671 | YS-15/... and YH-10/... | 12.6 |
| AYP-2310 | N13700672 | YS-23/... and YH-20/... | 12.1 |
| AYP-5010 | N13701058 | YS-50/... and YH-50/... | 19.6 |
| AYP-10010 | N13701059 | YS-100/... and YH-100/... | 46.0 |

Dimensions AYP

| Model | AYP-1010 | AYP-1510 | AYP-2310 | AYP-5010 | AYP-10010 |
|-------|-----------|-----------|----------|----------|-----------|
| A, mm | M57 x 1.5 | M67 x 1.5 | M85 x 2 | M125 x 2 | M180 x 3 |
| B, mm | 220 | 220 | 220 | 250 | 330 |
| C, mm | 200 | 200 | 200 | 250 | 330 |
| D, mm | 30 | 40 | 40 | 50 | 70 |
| E, mm | 120 | 120 | 120 | 225 | 300 |
| F, mm | 150 | 150 | 150 | 225 | 300 |
| G, mm | M12 | M12 | M12 | Ø 13.5 | Ø 17.5 |
| H, mm | M8 | M8 | M8 | M8 | M8 |

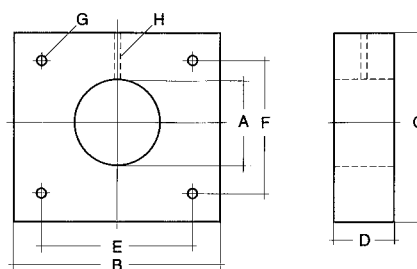

AYP

AYH

Clevis eye mountings

Clevis eye mountings are screwed onto the piston and bottom of the hydraulic cylinder whenever mounting conditions require a pivoting of the cylinder.



Technical data AYH

| Model | Art.-No. | Suitable for cylinder | Suitable for | Weight kg |
|----------|-----------|--|---------------|-----------|
| AYH-5-1 | N14500808 | YH-5/30, YH-5/80, YH-5/150 | Cylinder base | 0.3 |
| AYH-5-2 | N14500809 | YH-5/30, YH-5/80, YH-5/150 | Piston | 0.3 |
| AYH-10-1 | N14500810 | YH-10/30, YH-10/80, YH-10/150, YH-10/250 | Cylinder base | 0.6 |
| AYH-10-2 | N14500811 | YH-10/30, YH-10/80, YH-10/150, YH-10/250 | Piston | 0.6 |
| AYH-20-1 | N14500812 | YH-20/150, YH-20/250 | Cylinder base | 2.1 |
| AYH-20-2 | N14500813 | YH-20/150, YH-20/250 | Piston | 2.1 |

Dimensions AYH

| Model | AYH-5-1 | AYH-5-2 | AYH-10-1 | AYH-10-2 | AYH-20-1 | AYH-20-2 |
|---------------------|-----------|-----------|-----------|----------|----------|----------|
| A, mm | M27 x 2 | M18 x 1.5 | M36 x 2 | M27 x 2 | M45 x 2 | M36 x 2 |
| B, mm | - | 35 | - | 40 | - | 70 |
| C, mm | 35 | 35 | 38 | 38 | 50 | 50 |
| D, mm | 35 | 35 | 42 | 42 | 65 | 65 |
| E, mm | 15 | 15 | 25 | 25 | 35 | 35 |
| F, mm | 16 | 16 | 20 | 20 | 30 | 30 |
| G ¹ , mm | M35 x 1.5 | - | M40 x 1.5 | - | M70 x 2 | - |
| H, mm | - | - | - | 21 | - | 24 |
| J, mm | 18 | - | 21 | - | 23 | - |

¹G = retainer nut according to DIN 981

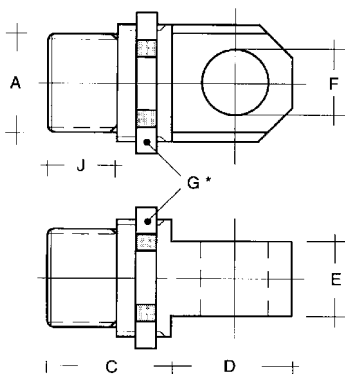

AYH-...-1 for cylinder base

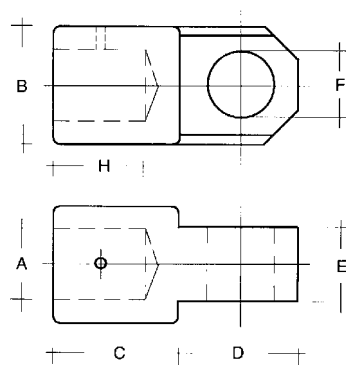

AYH-...-2 for piston

INFO

Build-up and description of Yale hand pumps

Hand pumps are the most common power source within the area of "High-Pressure Hydraulic Tools". For this reason our hand pumps have been carefully designed and equipped with many details which make the pumps very versatile and handy in every-day applications.

Relief valve/hand wheel

The fine-adjustment relief valve in connection with the large hand wheel allows millimeter increments when lifting and lowering even highest loads. The fact that sometimes hundreds of tons are controlled by this hand wheel underlines the importance of this feature.

Sturdy "all-metal-design"

The robust pump head and the absence of any plastic parts result in a long service life and easy maintenance over many years. Plastic reservoirs filled with oil may present a fire risk in connection with welding or similar work!

Carrying handle

A handy carrying handle on all our hand pumps facilitates transportation enormously.

Pressure relief valves

All hand pumps are equipped with two pressure relief valves. They are easily adjustable from outside if pumps must be re-adjusted or a lower operating pressure should not be exceeded.

Reservoir ventilation

All hand pumps are equipped with a reservoir ventilation plug. This ensures perfect suction of hydraulic oil and allows you to use the total oil capacity of the reservoir.

Two-stage output

All hand pumps have two-stage design (except HPS-1/0,7). This allows an increased speed and efficient working during unloaded conditions of the hydraulic cylinder. The switch-over from the low pressure to the high pressure stage is done automatically.

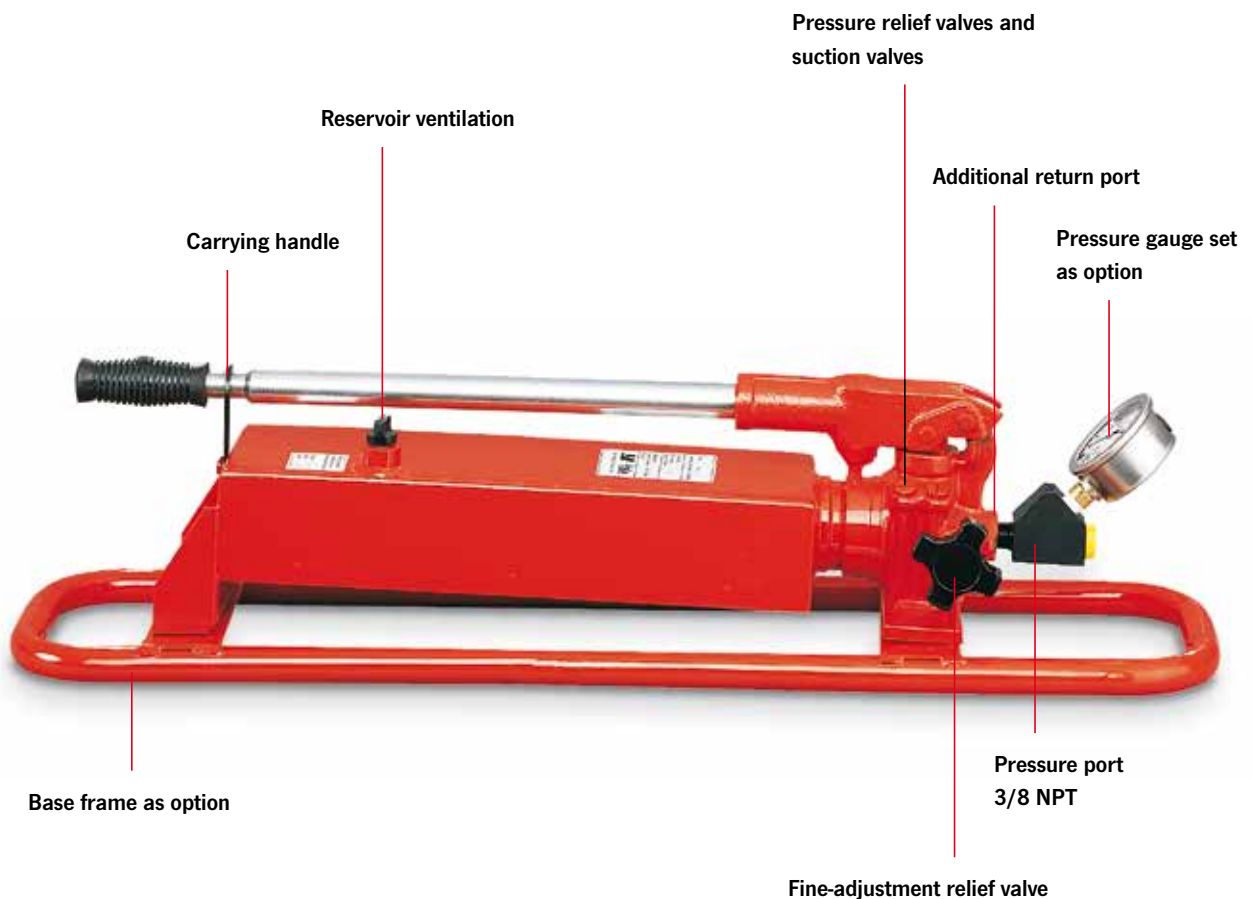

Delivered ready to use

All hand pumps are supplied ready to use incl. hydraulic oil.

Easy-maintenance-design

There is no need to disassemble the hand pumps in case of service work. All parts like suction and pressure valves, seals, packings etc. are accessible from the outside.

All hand pumps have the same design

The same design (build-up) for all hand pumps with the exception of the reservoirs allows the interchangeability of all components. Therefore spare part stocks can be kept to an absolute minimum. Only one spare part kit is necessary to service all hand pumps.

Excellent suction properties

Hand pumps suck and displace 100% of their volume per stroke. This results both in a high efficiency as well as a rapid cylinder movement.

Interchangeability

All hydraulic cylinders, hand pumps and other components are fully interchangeable and can be combined with all other 700 bar hydraulic lines. All components have the standard oil port and same coupler parts.

Additional return oil port

All hand pumps are equipped with a return port to the reservoir. This detail is very advantageous as many hand pumps are integrated in more complex hydraulic circuits.

Base frame

On request you can get base frames for the most common hand pumps. These base frames add to the stability and protection of the hand pumps, in particular when used in the field or on a construction site.

Pressure gauge

Appropriate pressure gauges with the corresponding adaptors are shown.

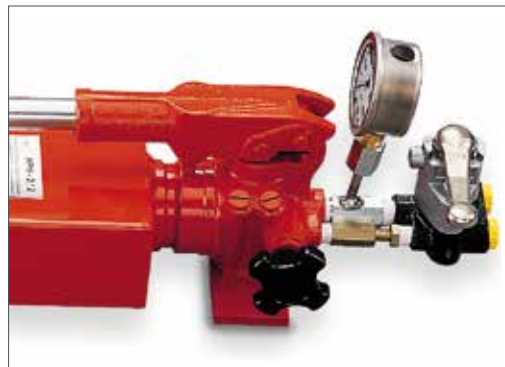

Hand pump HPH...

With integrated pressure gauge GGY-631 and gauge adaptor set GA-704.

Hand pumps for double-acting cylinders with relief valve and 4/2-way directional valve

Unlike conventional pumps, all hand pumps of the model HPH (with 4/2-way directional valve for double-acting cylinders) include a precision relief valve in addition to the directional control valve. Manual directional control valves switch over abruptly, thus causing undesired pressure surges in the system under load.

The additional relief valve in all HPH-hand pumps allows a precise lowering of the load without any pressure shocks. All components have the standard oil port and same coupler parts.

Further advantage of this design:

The pressure gauge shows the pressure as pushing and as pulling force. The combination of a 4-way directional valve with a sensitive relief valve allows a controlled pressure relief without pressure shocks.

OFFLINE

INFO

Selection charts "cylinder/hand pumps" can be found on pages 416-417.



HPS Hand pumps for single-acting cylinders

Hand pumps are easy to use and operate independently of any external energy source. They are designed for a maximum 700 bar system pressure and will allow each hydraulic cylinder to utilize its maximum capacity.

The two-stage system reduces pumping time.

Stage 1 allows rapid piston travel under no load or light load conditions. The pump automatically switches to stage 2 when the piston is loaded and a higher force is required from top. The hand pump is an all-steel construction designed for rough use and has a high-efficiency pumping action. The handle can be locked for easy carrying.

The large and easy-to-control return valve allows the operator to precisely control the return stroke. Other standard features include a large and easy-to-control hand wheel, air bleeding and oil filling plug, large support feet for stability, tilted tank to increase usable oil volume and ergonomic handle grip.

Features

- Operating pressure max. 700 bar.
- Two-stage operation with automatic switch-over (except HPS-1/0,7 A).
- Large reservoir volumes.
- With pressure relief valves, adjustable from the outside.
- Precision-adjustable relief valve (handwheel).
- Robust all-steel construction.
- HPH-pumps are equipped with a 4-way control valve plus a precision-adjustable relief valve.
- Oil port thread 3/8 NPT.
- Incl. oil filling.

Option

- Pressure gauges with corresponding adaptors are also available as accessories.

INFO

Hydraulic hoses are the connection between hand pump and hydraulic cylinders and need to be selected separately. Please see page 391.

Technical data HPS

| Model | Art.-No. | Displacement | Reservoir volume cm ³ | Displacement 1 st stage cm ³ | Displacement 2 nd stage cm ³ | Weight kg |
|-------------|-----------|--------------|-------------------------------------|--|--|--------------|
| HPS-1/0,7 A | N12101011 | single-stage | 700 | – | 2 | 7.0 |
| HPS-2/0,3 A | N12101127 | two-stage | 300 | 5 | 1 | 3.5 |
| HPS-2/0,7 A | N12101012 | two-stage | 700 | 11 | 2 | 7.0 |
| HPS-2/1,3 A | 192085595 | two-stage | 1300 | 11 | 2 | 9.0 |
| HPS-2/2 A | N12101013 | two-stage | 2000 | 11 | 2 | 10.0 |
| HPS-2/4 A | N12101014 | two-stage | 4000 | 11 | 2 | 13.0 |
| HPS-2/6 A | N12101015 | two-stage | 6000 | 11 | 2 | 21.0 |
| HPS-2/10 A | N12101016 | two-stage | 10000 | 11 | 2 | 27.0 |

Dimensions HPS

| Model | HPS-1/0,7 A | HPS-2/0,3 A | HPS-2/0,7 A | HPS-2/1,3 A | HPS-2/2 A | HPS-2/4 A | HPS-2/6 A | HPS-2/10 A |
|-------|-------------|-------------|-------------|-------------|-----------|-----------|-----------|------------|
| A, mm | 505 | 410 | 505 | 630 | 520 | 645 | 645 | 800 |
| B, mm | 85 | 100 | 85 | 80 | 70 | 65 | 65 | 65 |
| C, mm | 135 | 105 | 135 | 135 | 145 | 160 | 215 | 250 |
| D, mm | 150 | 125 | 150 | 150 | 150 | 150 | 180 | 190 |
| E, mm | 43 | 35 | 43 | 43 | 43 | 43 | 43 | 43 |
| F, mm | 52 | 35 | 52 | 52 | 52 | 52 | 52 | 52 |

Dimensions approx.

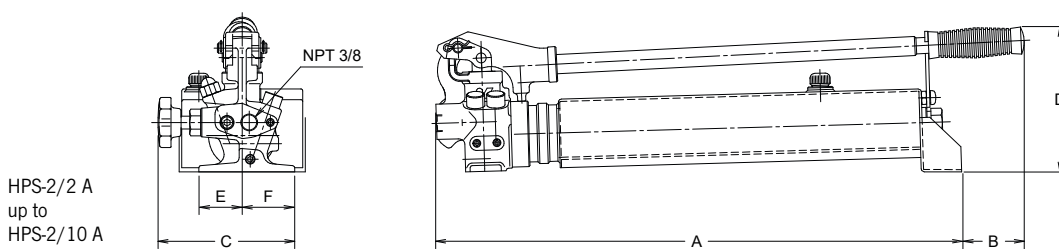
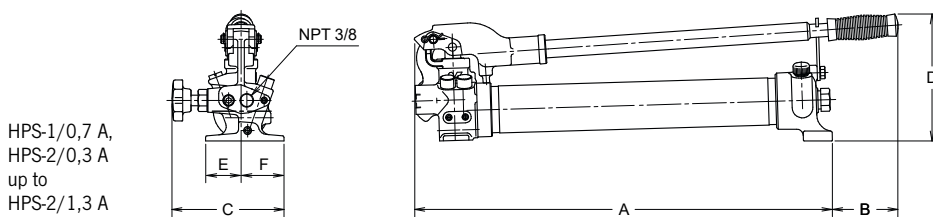



HPH Hand pumps for double-acting hydraulic cylinders

With 4-way valve and relief valve (hand wheel)

All hand pumps of type HPH are designed as double-acting cylinders. Basically, they do not differ from series HPS, but are equipped with a 4/3-way directional valve.

The precision-adjustable relief valve remains unaffected and permits a sensitive pressure relief.

Option

- Pressure gauges with corresponding adaptors are also available as accessories.

Technical data HPH

| Model | Art.-No. | Displacement | Reservoir volume cm ³ | Displacement 1 st stage cm ³ | Displacement 2 nd stage cm ³ | Weight kg |
|-------------|-----------|--------------|-------------------------------------|--|--|--------------|
| HPH-2/0,7 A | N12101018 | two-stage | 700 | 11 | 2 | 8 |
| HPH-2/2 A | N12101019 | two-stage | 2000 | 11 | 2 | 11 |
| HPH-2/4 A | N12101020 | two-stage | 4000 | 11 | 2 | 14 |
| HPH-2/6 A | N12101021 | two-stage | 6000 | 11 | 2 | 22 |
| HPH-2/10 A | N12101022 | two-stage | 10000 | 11 | 2 | 28 |

Dimensions HPH

| Model | HPH-2/0,7 A | HPH-2/2 A | HPH-2/4 A | HPH-2/6 A | HPH-2/10 A |
|-------|-------------|-----------|-----------|-----------|------------|
| A, mm | 505 | 520 | 645 | 645 | 800 |
| B, mm | 85 | 70 | 65 | 65 | 65 |
| C, mm | 160 | 160 | 160 | 200 | 160 |
| D, mm | 150 | 150 | 150 | 180 | 190 |
| E, mm | 43 | 43 | 43 | 43 | 43 |
| F, mm | 52 | 25 | 52 | 52 | 52 |
| G, mm | 85 | 85 | 85 | 85 | 85 |

Dimensions approx.

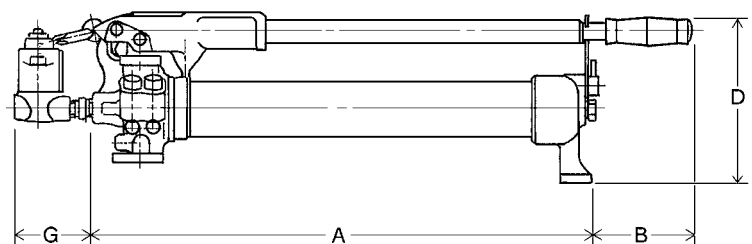
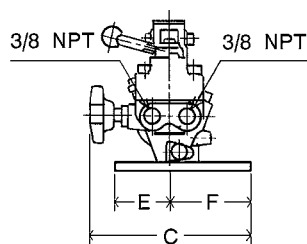

HPB

Base frames for hand pumps

These base frames add to the stability of your hand pump, in particular when used in the field or on a construction site where hand pumps are frequently operated on uneven and soft ground.

At the same time, the hand pumps are protected from sand, humidity and possible damage.

The assembly of the base frames is very easy; just three holes have to be bored to mount the frame to the hand pump.



Technical data HPB

| Model | Art.-No. | Suitable for hand pump | Weight kg |
|-------|-----------|---|-----------|
| HPB-2 | N14500205 | HPS-1/0,7 A + HPS-2/0,7 A + HPS-2/2 A + HPH-2/0,7 A + HPH-2/2 A | 1.3 |
| HPB-4 | N14500206 | HPS-2/4 A + HPS-2/6 A + HPH-2/4 A + HPH-2/6 A | 1.8 |

Dimensions HPB

| Model | HPB-2 | HPB-4 |
|-------|-------|-------|
| A, mm | 765 | 885 |
| B, mm | 190 | 190 |

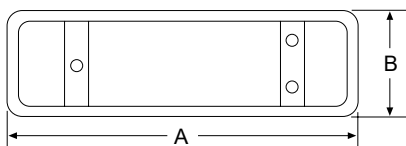



TWAZ Hand pumps model

Operating pressure max. 2000 bar

These high-performance hand pumps allow a very rapid pressure build-up due to their two-stage design. Both pressure stages are equipped with a limiting valve which can easily be adjusted from outside.

High-pressure hand pumps are used for special applications like pressurizing hydraulic nuts and safety couplings, hydrostatic testing, bolt tensioners, high-pressure oil injection for bushing removal, pretensioning anchors, for test applications in laboratories and as a power source within test stands and propeller press systems.

Accessories for hand pumps TWAZ



Option:
pressure gauge,
GGY-2500.



Option:
pressure gauge-adaptor,
GA-2000.



Option:
adaptor,
FY-201
(M22 x 1.5 on G 1/4).



Option:
hydraulic hoses,
HH-2001-20,
max. pressure: 2000 bar.

Technical data TWAZ

| Model | Art.-No. | Pressure max. bar | Reservoir volume cm ³ | Displacement 1 st stage cm ³ | Displacement 2 nd stage cm ³ | Oil port | Pressure gauge | Pressure gauge model | Gauge adaptor model | Pressure relief valve | Weight kg |
|----------|-----------|----------------------|-------------------------------------|--|--|-----------|----------------|----------------------|---------------------|-----------------------|--------------|
| TWAZ-0,7 | N12201100 | 2000 | 700 | 8 | 0.6 | M22 x 1.5 | optional | GGY-2500 | GA-2000 | yes | 7.0 |
| TWAZ-1,3 | N12201101 | 2000 | 1300 | 13 | 1.0 | M22 x 1.5 | optional | GGY-2500 | GA-2000 | yes | 9.0 |
| TWAZ-2,3 | N12201102 | 2000 | 2300 | 31 | 1.6 | M22 x 1.5 | optional | GGY-2500 | GA-2000 | yes | 16.0 |

FPS Foot pump

Operating pressure 700 bar

Used to operate single-acting hydraulic cylinders, especially for repeated applications, such as checking of welding samples, pressing of connection components (crimping), actuating of clamping devices, as well as for all applications, where it is necessary to keep hands free.

The pump can be used everywhere, as it is independent of an external energy source and is easily portable. An extremely good stability guarantees a comfortable and safe operation up to the highest pressure. It is a “real” foot operated pump, as the return stroke of the connected hydraulic cylinder is released by foot control.

Features

- Operating pressure max. 700 bar.
- Absolute stability due to large base plate.
- Minimized labour fatigue.
- Operating pressure adjustable. Valves accessible from the outside.
- Return stroke of cylinder also controlled by foot operation.
- Oil port 3/8 NPT.

Options

- Pressure gauges and suitable adaptors.
- Hydraulic hoses



Technical data FPS

| Model | Art.-No. | Operating pressure max. bar | Displacement 1 st stage cm ³ | Displacement 2 nd stage cm ³ | Reservoir volume useable cm ³ | Weight kg |
|-------------|-----------|-----------------------------|--|--|--|-----------|
| FPS-2/0,5 A | N12501128 | 700 | 11 | 2 | 500 | 7 |

INFO

The Yale Electric power pack PYB

Hand pumps are the most common power source within the area of "High-Pressure Hydraulic Tools". Using a hand pump can require a higher force. The new cordless power pack PYB is a highly efficient replacement for a standard hydraulic hand pump.

Adding this pump to our sales programme enables us to offer four pump types - giving the user more flexible options to choose from.

Relief valve

The fine-adjustment relief valve in connection with the lever allows millimeter increments when lifting and lowering even the highest loads. The fact that sometimes hundreds of tons are controlled by this hand wheel underlines the importance of this feature.

Robust aluminium/metal construction

The aluminium die-cast housing ensures low weight and protects the battery. Plastic reservoirs filled with oil may present a fire risk in connection with welding or similar hot work!

Shoulder belt

A shoulder belt can be attached to the lifting eyes making it easier to carry the pump.

Pressure relief valves

The electric power packs PYB are equipped with two internal pressure relief valves. The high pressure stage is set to a maximum operating pressure of 700 bar, to avoid over-pressurization of the system.

NEW DEVELOPMENT
CORDLESS TECHNOLOGY
FOR MOBILE OPERATION



Rubber tank bladder

The rubber tank bladder of the PYB enables the pump to be used in any position. The total available oil volume can be used.

Two-stage output

Both PYB power packs have a two-stage design. This allows increased speeds and efficient working during unloaded conditions of the hydraulic cylinder. The switch-over from the low pressure to the high pressure stage is done automatically.

Both pumps PYB are “identical”.

Except for the reservoir and the cover both units are identical. Which means that nearly all parts are interchangeable.

So keeping spare parts can be minimized, e.g. only one seal kit has to be stocked to service both pumps

Excellent suction properties

Hand pumps draw and displace 100% of their volume per stroke. This results both in a high efficiency as well as a rapid cylinder movement.

Interchangeability

All hydraulic cylinders, hand pumps and other components are fully interchangeable and can be combined with all other 700 bar hydraulic lines. The PYB is equipped with a female coupler half CFY-1

Pressure gauge

Appropriate pressure gauges with the corresponding adaptors are shown in this catalogue.



Cordless power pack: PYB-1,0 c/w optional gauge adaptor set GYA-63.

Battery and charger

The batteries and chargers are HIKOKI original parts and are commercially available. Which means every customer can decide if and how many batteries and chargers they want to order with Columbus McKinnon or if they want to purchase the necessary parts locally.



Possible applications and devices to be combined



Lifting wedges
HK-16T
16t



Spreading wedges
YSW-14T
14t



Low-profile and flat cylinders
YLS and YFS
10 - 100t



Spreaders
YHS
0.5 - 1.5t



Nut splitters
YNS/YNS-AH
SW 11 - 89mm



PYB-1,0
with optional
pressure gauge
GYA-63

PYB-0,6

PYB Elektric power pack, battery driven

Operating pressure max. 700 bar

The Yale PYB cordless power pack provides a flexible edition to the Yale hydraulic programme.

This extremely compact and lightweight power pack gives the user the freedom to operate in areas where there is no power source, increasing productivity over the conventional hand pump and all at the push of a button.

The power pack utilises a standard HiKOKI LH-ION battery and charger to maximize operation.

Ideal for a range of applications using small to mid size single-acting cylinders, hydraulic spreaders, lifting wedges nut splitters and much more.

Features

- Operating pressure max. 700 bar
- One-Hand-Operation. Push-button integrated into ergonomic handle.
- Two-stage operation with automatic switch-over.
- With internal pressure relief valve.
- Reservoir made from aluminium, extreme low weight.
- Protective cover to prevent inadvertent switch on of pump.
- Rubber tank bladder enables the pump to be used in any position.

Options/Accessories

Standard HiKOKI batteries (Typ BSL36A18x2) and chargers are exclusively used.

- Battery model PYB-BAT, 18V, weight 0.7 kg
Art.-No. 192043950
- Quick-charger model PYB-CHARG,
230V and 12V (car plug socket incl.)
Art.-No. 192043961
- Pressure gauge set model GYA-63 consisting of:
gauge GGY 632, Ø 63 mm, 0 - 1000 bar and adaptor.
Art.-No. N14200497
- Hydraulic hose model HHC (to complete the connection a male coupler half CMY-1 is required)

Scope of delivery

- Electric power pack, battery driven
- Oil filled ready for work
- Female coupler half CFY-1
- Shoulder belt



Ideal application in combination with compact, portable hydraulic tools like spreaders, lifting wedges, low profile and flat cylinders as well as nut splitters.

Technical data PYB

| Model | Art.-No. | Displacement | Reservoir volume | Displacement 1 st stage | Displacement 2 nd stage | Weight without battery | Operational weight c/w battery |
|---------|-----------|--------------|------------------|------------------------------------|------------------------------------|------------------------|--------------------------------|
| | | | cm ³ | l/min | l/min | kg | kg |
| PYB-0,6 | 192043421 | two-stage | 600 | 0.7 | 0.06 | 4.8 | 5.5 |
| PYB-1,0 | 192043988 | two-stage | 1000 | 0.7 | 0.06 | 5.7 | 6.4 |

Dimensions PYB

| Model | PYB-0,6 | PYB-1,0 |
|-------|---------|---------|
| A, mm | 245 | 290 |
| B, mm | 100 | 100 |
| C, mm | 120 | 120 |
| D, mm | 200 | 229 |
| E, mm | 148 | 166 |
| F, mm | 88 | 106 |

Dimensions approx.

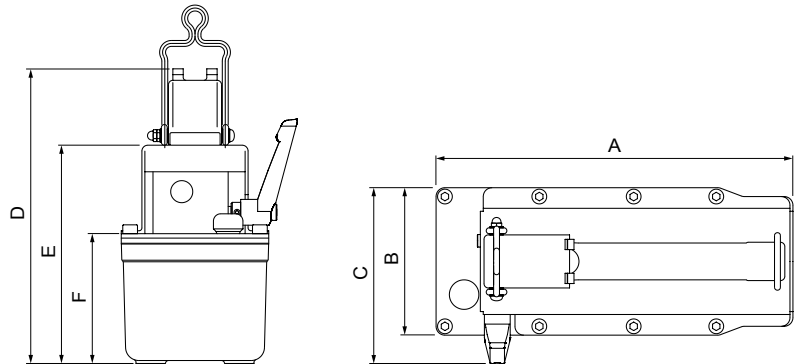

INFO

Battery and charger are not supplied in the standard scope of delivery. These items must be ordered separately.

Comparison

| Cylinder size t | Hand pump | | Electric power pack PYB | |
|--------------------|--------------------------------------|------------------------------------|-------------------------|------|
| | No. of pump strokes for 10 mm stroke | | Piston travel speed | |
| | HPS-2/0,7 A up to HPS-2/10 A LP | HPS-1/0,7 A up to HPS-2/10 A HP | in mm/s | |
| | LP | HP | LP | HP |
| 5 | 1 | 4 | 16.2 | 1.4 |
| 10 | 1 | 7 | 8.2 | 0.7 |
| 15 | 2 | 11 | 5.4 | 0.5 |
| 20 | 2 | 14 | 4.1 | 0.35 |
| 21 | 2 | 15 | 3.8 | 0.33 |
| 23 | 3 | 17 | 3.5 | 0.3 |
| 30 | 3 | 22 | 2.7 | 0.23 |

LP = Low-pressure stage (unloaded stroke)
HP = High-pressure stage (loaded stroke)



Shoulder belt



Hydraulic hose
HHC



Optional pressure gauge set
GYA-63



Quick-charger
PYB-CHARG



Battery
PYB-BAT



One-Hand-Operation
push-button integrated into ergonomic handle.



PY-04/2/5/2M

PY-04/2/5/4M

Operation of the power pump

PY-04/2/5/2E:

By activating push-button number 1, the motor starts and the cylinder advances. In the neutral position the pressure is held. By activating push-button number 2, the solenoid valve is activated, the pressure decreases and the hydraulic cylinder retracts.

PY-04

Electric motor pumps, portable

Operating pressure max. 700 bar

These light-weight but powerful two-stage pumps are particularly designed for maintenance and repair jobs. Depending on their type, they can either operate single-acting or double-acting hydraulic cylinders.

The ideal combination of manually operated valve and remote pendant control provides the operator with ample freedom of motion and ensures a safe “holding of the load”.

The remote pendant control (1.5 m) is used to start the motor even under full load. The function for both manual valves is as follows: – advance – hold – return – With their light weight and convenient carrying handle, these pumps can be easily transported. Pumps are equipped with thermal overload protection and are supplied with hydraulic oil.

Operation of the power pump

PY-04/2/5/2M:

The 2/2-way manual valve operates together with a pilot operated unloading valve, so that the two valve positions result in the following two control possibilities:

Valve handle position 1:

Cylinder holds pressure after motor stop.

Valve handle position 2:

Cylinder automatically retracts after motor stop.

Technical data PY-04

| Model | Art.-No. | Control valve | Operating pressure max. bar | No load stroke l/min up to 30 bar | Under load stroke l/min up to 700 bar | Useable reservoir volume l | Connecting value | Cable remote control m | Speed rpm | Protection standard | Weight, without oil, approx. kg |
|---------------|-----------|----------------------|-----------------------------|-----------------------------------|---------------------------------------|----------------------------|---------------------|------------------------|-----------|---------------------|---------------------------------|
| PY-04/2/5/2 M | N12300132 | 2/2-way manual valve | 700 | 40 | 0.23 | 5.0 | 0.37 kW - 230 V-1Ph | 1.5 | 2800 | IP 50 | 24 |
| PY-04/2/5/4 M | N12300193 | 4/3-way manual valve | 700 | 4.0 | 0.23 | 5.0 | 0.37 kW - 230 V-1Ph | 1.5 | 2800 | IP 50 | 26 |
| PY-04/2/5/2 E | N12300043 | 2/2-way solenoid | 700 | 4.0 | 0.23 | 5.0 | 0.37 kW - 230 V-1Ph | 1.5 | 2800 | IP 50 | 28 |

PAY Mini hydraulic pumps, with compressed air driven motor

Operating pressure max. 700 bar

These mini-pumps are driven by an air-powered motor and can be connected to any supply source of compressed air. These compact low-cost pumps can operate all single-acting or double-acting hydraulic cylinders up to a max. operating pressure of 700 bar.

Due to large reservoirs, large cylinders or multiple cylinders can be operated. The use of an inline air filter-lubricator is recommended.

The hydraulic pressure can be infinitely adjusted on the regulator of the air-lubricator unit. The air-driven motor guarantees 100% explosion protection.

Pumps for double-acting hydraulic cylinders are equipped with an additional 4-way control valve type VHH-4/3. The connected hydraulic cylinder is controlled – advance – hold – return – by the universal pedal, which can be either hand or foot-operated.



Control of cylinder motion

- Pedal in neutral position – motor stands still, cylinder stands, pressure is held.
- Pedal depressed – motor starts, cylinder advances, pressure is built-up.
- Pedal pushed forward – motor stands still, pressure is released, cylinder retracts.

Technical data PAY

| Model | Art.-No. | For cylinders | Reservoir volume l | Oil pressure max. bar | Oil displacement l/min | Required air pressure bar | Air consumption l/min | Oil port | Air port | Weight kg |
|----------|-----------|---------------|--------------------|-----------------------|------------------------|---------------------------|-----------------------|----------|----------|-----------|
| PAY-6 | N12300133 | single-acting | 1.5 | 700 | 1.28 - 0.14 | 7 | 560 | 3/8 NPT | 1/4 NPT | 6.3 |
| PAY-6-5 | N12300715 | single-acting | 5.0 | 700 | 1.28 - 0.14 | 7 | 560 | 3/8 NPT | 1/4 NPT | 12.0 |
| PAY-64 | N12300279 | double-acting | 1.5 | 700 | 1.28 - 0.14 | 7 | 560 | 3/8 NPT | 1/4 NPT | 7.5 |
| PAY-64-5 | N12300006 | double-acting | 5.0 | 700 | 1.28 - 0.14 | 7 | 560 | 3/8 NPT | 1/4 NPT | 13.0 |

INFO



PY-11/3/20/4M



PY-07/3/10/3E

PYE and PY

Electric hydraulic power packs

Single-stage and two-stage

Power packs are easy to operate as they are fully assembled and easy to control.

The use of power packs is always recommended when jobs have to be done in a time-saving and efficient way, when repeating jobs have to be finished off, quick cylinder cycles have to be achieved or if large oil volumes in connection with high-tonnage cylinders have to be transmitted.

Two-stage output

The standard power packs are equipped with two-stage pumps, which means that a low pressure stage fills the connected hydraulic cylinder quickly up to a pressure of 80 bar. The high pressure stage is activated automatically from 80 bar up to 700 bar, while the low pressure stage is discharged back to the reservoir. This economic solution avoids heating-up, saves energy and keeps the power packs compact.

Single-stage output model PYE

The hydraulic packs have single-stage pumps. These packs deliver between 0 and 700 bar with the same volume (high-pressure stage).

Control/Operation

The motion control of the connected hydraulic cylinder is done by operating the directional valve.

Do you have a single-acting or a double-acting hydraulic cylinder?

The directional control valve has to correspond to the a.m. functional principle of the hydraulic cylinder to be operated. Depending on these principles the power packs are equipped with a:

- 3/3-way valve to operate single-acting hydraulic cylinders (connection with one hydraulic hose)
- 4/3-way valve to operate double-acting hydraulic cylinders (connection with two hydraulic hoses)

The directional control valves are available either as manual or solenoid operated valves.

Operation of the directional valves

Depending on the way of operation, there are manual or solenoid operated valves. Manual valves are controlled by shifting the operating lever and represent the economic way of control.

These valves have 3 lever positions:
– advance – hold – return –

Solenoid valves

Solenoid valves have the advantage that they are controlled by a pendant remote control box which makes the operator independent from the power pack, making it easier for him to monitor the job.

The solenoid valves are controlled by two push-buttons – **advance** – **return** –

In neutral position – **hold** – the valves rest in pressure-less circuit. Pressure and force of the connected cylinder are held without pressure drop. The complete electrical set-up (with 24V control) belongs to the scope of delivery. Solenoid valves allow a very ergonomic operation and offer a quick and precise switching (millimeterwise) of the connected hydraulic cylinder.

Pressureless circuit

In neutral position all directional valves rest in pressure-less circuit which means that the oil flow coming from the rotating pump is guided back to the reservoir without creating any pressure build-up.

Special solenoid valve configurations

Some applications require a special valve configuration, e.g. the independent control of several hydraulic cylinders from a single power pack. In such cases the complete valve build-up and electrical control is designed according to customer's requirements.

Pressure-Guard power packs

By using an electro-hydraulic pressure switch and a special electric control, power packs automatically control their pre-adjusted pressure. In applications where the pressure (load) should be applied over a very long period, the connected power pack is switched on and off automatically and replaces the pre-set pressure in case a pressure drop has occurred.

Trolleys

For all power packs we offer a cart-frame for flexible movement from job to job. Cart-frames are equipped with 2 fixed and 2 swivel castors.

Oil cooler

For certain applications, especially when power packs are continuously operated and the oil temperature could exceed 60 °C, the use of an oil cooler is recommended.

Hydraulic oil

All power packs are designed for an operation with standard hydraulic oil (specification ISO VG 32).

For certain operating conditions the viscosity class of the hydraulic fluid can be varied.

All power packs are supplied including oil.

Features

- Robust packs, also capable for continuous applications.
- Suitable for all jobs in workshops and on construction sites where hydraulic force is required; supplied ready to use.
- On-off motor switch and 3 m motor connecting cable.
- With carrying handles, oil level gauge, oil filler/reservoir ventilation plug.
- Incl. pressure gauge GGY-631.
- Two-stage displacement, which means a rapid advance without load, as well as an automatic switch into the 2. phase by a congruous load.
- Low noise level due to standard motors with 1450 rpm.
- Further motor voltage and oil reservoirs on request.
- With manual or solenoid operated directional valves.
- Solenoid valves with 3 m remote control box (with 2 push-buttons) and pressure set valve as standard. Adjustable from 0 - 700 bar.
- 24V - low voltage control includes a sturdy metal electric control box and ready to use set up.



Two-stage electric hydraulic power packs, 700 bar

| Model | Reservoir size | | | | Control valve (directional valve) | | | | Motor-power kw | Displacement, two-stage | |
|----------------|----------------|------|------|------|-----------------------------------|---------|----------------|---------|----------------|--------------------------|----------------------------|
| | 10 l | 20 l | 30 l | 50 l | manual valve | | solenoid valve | | | approx. l/min 0 - 80 bar | approx. l/min 80 - 700 bar |
| | | | | | 3/3-way | 4/3-way | 3/3-way | 4/3-way | | | |
| PY-07/3/10/3 M | • | – | – | – | • | – | – | – | 0.75 | 6.0 | 0.6 |
| PY-07/3/10/4 M | • | – | – | – | – | • | – | – | 0.75 | 6.0 | 0.6 |
| PY-07/3/20/3 M | – | • | – | – | • | – | – | – | 0.75 | 6.0 | 0.6 |
| PY-07/3/20/4 M | – | • | – | – | – | • | – | – | 0.75 | 6.0 | 0.6 |
| PY-07/3/20/3 E | – | • | – | – | – | – | • | – | 0.75 | 6.0 | 0.6 |
| PY-07/3/20/4 E | – | • | – | – | – | – | – | • | 0.75 | 6.0 | 0.6 |
| | | | | | | | | | | | |
| PY-11/3/20/3 M | – | • | – | – | • | – | – | – | 1.1 | 8.5 | 1.0 |
| PY-11/3/20/4 M | – | • | – | – | – | • | – | – | 1.1 | 8.5 | 1.0 |
| PY-11/3/30/3 M | – | – | • | – | • | – | – | – | 1.1 | 8.5 | 1.0 |
| PY-11/3/30/4 M | – | – | • | – | – | • | – | – | 1.1 | 8.5 | 1.0 |
| PY-11/3/20/3 E | – | • | – | – | – | – | • | – | 1.1 | 8.5 | 1.0 |
| PY-11/3/20/4 E | – | • | – | – | – | – | – | • | 1.1 | 8.5 | 1.0 |
| PY-11/3/30/3 E | – | – | • | – | – | – | • | – | 1.1 | 8.5 | 1.0 |
| PY-11/3/30/4 E | – | – | • | – | – | – | – | • | 1.1 | 8.5 | 1.0 |
| | | | | | | | | | | | |
| PY-22/3/30/3 M | – | – | • | – | • | – | – | – | 2.2 | 18.0 | 2.1 |
| PY-22/3/30/4 M | – | – | • | – | – | • | – | – | 2.2 | 18.0 | 2.1 |
| PY-22/3/50/3 M | – | – | – | • | • | – | – | – | 2.2 | 18.0 | 2.1 |
| PY-22/3/50/4 M | – | – | – | • | – | • | – | – | 2.2 | 18.0 | 2.1 |
| PY-22/3/30/3 E | – | – | • | – | – | – | • | – | 2.2 | 18.0 | 2.1 |
| PY-22/3/30/4 E | – | – | • | – | – | – | – | • | 2.2 | 18.0 | 2.1 |
| PY-22/3/50/3 E | – | – | – | • | – | – | • | – | 2.2 | 18.0 | 2.1 |
| PY-22/3/50/4 E | – | – | – | • | – | – | – | • | 2.2 | 18.0 | 2.1 |

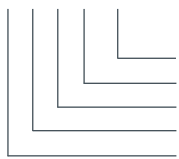

Code explanation

- Directional valve : 3 = for single-acting, 4 = for double-acting cylinder, M = manual valve, E = solenoid valve
- Reservoir size : in liters (other reservoir sizes on request)
- Motor voltage : 3 = 380-420 V, 3-phase (Euro-voltage), 2 = 230 V, 1-phase, (other voltages on request)
- Hoist motor : 07 = 0.75 kW, 11 = 1.1 kW, 22 = 2.2 kW, 30 = 3 kW, 55 = 5.5 kW, 75 = 7.5 kW, 110 = 11 kW
- Type of motor : PY = electric motor, PAY = air motor, PGY = petrol driven motor (4 cycle)

Single-stage electric hydraulic power packs, 700 bar

| Model | Reservoir size | | | | Control valve (directional valve) | | | | Motor-power kw | Displacement l/min 0 - 700 bar |
|-----------------|----------------|------|------|------|-----------------------------------|---------|----------------|---------|----------------|--------------------------------|
| | 10 l | 20 l | 30 l | 50 l | manual valve | | solenoid valve | | | |
| | | | | | 3/3-way | 4/3-way | 3/3-way | 4/3-way | | |
| PYE-03/3/10/3 M | • | – | – | – | | | | | 0.35 | 0.3 |
| PYE-03/3/10/4 M | • | – | – | – | | | | | 0.35 | 0.3 |
| PYE-07/3/10/3 M | • | – | – | – | | | | | 0.75 | 0.6 |
| PYE-07/3/10/4 M | • | – | – | – | | | | | 0.75 | 0.6 |
| PYE-07/3/20/4 M | – | • | – | – | | | | | 0.5 | 0.6 |
| PYE-11/3/20/3 M | – | • | – | – | | | | | 1.1 | 1.0 |
| PYE-11/3/20/4 M | – | • | – | – | | | | | 1.1 | 1.0 |
| PYE-11/3/30/4 M | – | – | • | – | | | | | 1.1 | 1.0 |
| PYE-22/3/20/3 M | – | • | – | – | | | | | 2.2 | 2.1 |
| PYE-22/3/20/4 M | – | • | – | – | | | | | 2.2 | 2.1 |
| PYE-22/3/30/4 M | – | – | • | – | | | | | 2.2 | 2.1 |
| PYE-22/3/50/4 M | – | – | – | • | | | | | 2.2 | 2.1 |

All valve and reservoir combinations available.

High-performance electric hydraulic power packs, 700 bar, single-stage

| Model | Reservoir size | | | | Control valve (directional valve) | | | | Motor-power kw | Displacement l/min 0 - 700 bar |
|-------------------|----------------|------|-------|-------|-----------------------------------|---------|----------------|---------|----------------|--------------------------------|
| | 50 l | 70 l | 100 l | 150 l | manual valve | | solenoid valve | | | |
| | | | | | 3/3-way | 4/3-way | 3/3-way | 4/3-way | | |
| PYE-40/3/50/4 M | • | – | – | – | | | | | 4.0 | 2.7 |
| PYE-55/3/70/4 M | – | • | – | – | | | | | 5.5 | 4.0 |
| PYE-75/3/100/4 M | – | – | • | – | | | | | 7.5 | 6.0 |
| PYE-110/3/150/4 M | – | – | – | • | | | | | 11.0 | 8.0 |
| PYE-180/3/150/4 M | – | – | – | • | | | | | 18.0 | 12.0 |

All valve and reservoir combinations available.

Hydraulic power pack with protection cage

This power pack is specially designed for general lifting applications in construction areas. Equipped with an optimized valve configuration, including 4-way manual directional valve VHP-4/3-1, safety-check valve VSM-21, pressure relief valve VPR-1 and two pressure gauges for permanent load control.



Hydraulic power pack with 4-way manifold MY-44-GYA

The most economic way for a pressure-independent and individual control of four single-acting hydraulic cylinders. The additionally mounted safety-check valve VSM-21 avoids uncontrolled pressure drops, and the built-in throttle valve allows a precise (millimeterwise) lowering even of the highest loads. Four pressure gauges allow a permanent reading of the individual loads. On request, the power packs can be equipped with a handy cart-frame to make the operation flexible. This type of power pack can be supplied in all sizes of the PY and PYE series.



Hydraulic power pack with 4-times solenoid valve

The quadruple solenoid valve block ensures a pressure-independent and individual control of four double-acting hydraulic cylinders. Solenoid valves offer several well-known advantages such as: ergonomic and safe control by pendant remote control, exact load hold, precise and quick switch characteristics and many more.



Double-hydraulic power pack

In order to realise very high oil flows, two independent pump systems can be combined in one large reservoir. A gear pump ensures an extremely high oil flow up to 250 bar while the high-pressure stage is generated by a high-performance radial piston pump. Each pump is equipped with its own solenoid control valve so that the individual oil flows can be generated or discharged on request.





PMF-15/3/40/4 x 3 M

PMF Multiple-flow hydraulic power packs

Multiple-flow hydraulic pumps can advance four cylinders with the same speed at the same time by injecting equal amounts of hydraulic oil into each individual cylinder. This principle allows a synchronized lifting of machines or similar loads from a central point. Even under different loading conditions the cylinders advance in synchronisation.

Levelling of a lopsided load is easily possible by an individual control of each single cylinder. The lifting phase is initiated by a push-button remote control box and can be interrupted and continued at any time.

Lowering of the load is done by operating the directional valve in connection with the throttle valve individually for each circuit. The multiple-flow pumps can drive all kinds of hydraulic cylinders, machine jacks or stage lifts.

Features

- 4-point synchronized lift due to 4 equal, independent and individual oil flows.
- 4 manually operated directional valves, or 4 solenoid directional valves allow an individual or joint control of all 4 connected cylinders (easy levelling of loads).
- Safe load hold due to check valve in each circuit.
- One-man central operation.
- Motor on-off switch by means of a pendant remote control box in connection with manual valves
- A complete remote control box to operate the solenoid valves.

Options

- All pump packs are also available with 4/3 direction-valves (for controlling the double-acting hydraulic cylinders).
- All power packs can be supplied with a protection frame suitable for on-site operation. Also cart-frames with 2 fixed and 2 swivel castors are available on request.

Scope of delivery

For each of the four circuits the ready-to-use supply includes: glycerine-damped pressure gauge, 3-way control valve, safety-check valve, a female coupler-half as connecting port. Furthermore: hydraulic oil, carrying handles, motor on-off switch, motor connecting cable, pendant remote control, electro-box with transformer and motor relais, oil level gauge and oil-filler/ventilation plug. All multiple-flow power packs are also available with 4-way directional valves in order to operate double-acting hydraulic cylinders.

INFO

All extra loads can be meter-read permanently.

PMF

4-multiple-flow power packs with solenoid directional valves

4-multiple-flow power packs with solenoid directional valves to advance 4 hydraulic cylinders independently and in a synchronized way by means of solenoid valves with a pendant remote control box.

The solenoid valves in connection with safety-throttle valves allow a precise control of all connected hydraulic cylinders.

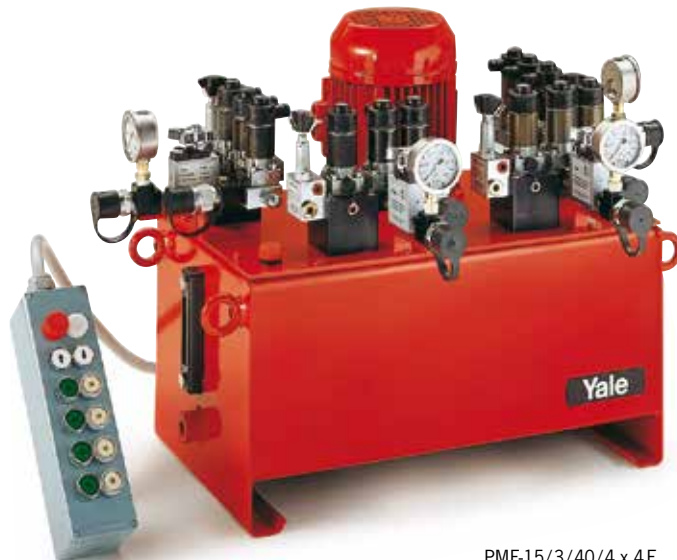

PMF-15/3/40/4 x 4 E

Technical data PMF

| Model | Art.-No. | Operating pressure max. bar | Displacement l/min | Manual valve | Solenoid valve | Motor remote control | Reservoir size l | E-motor |
|-----------------------|-----------|-----------------------------|--------------------|--------------|----------------|----------------------|------------------|------------------------|
| PMF-07/3/20/2 x 3 M | N12300047 | 2 x 700 | 2 x 0.3 | • | – | • | 20 | 0.75 kW - 400 V - 3 Ph |
| PMF-07/3/20/2 x 3 E | – | 2 x 700 | 2 x 0.3 | – | • | – | 20 | 0.75 kW - 400 V - 3 Ph |
| PMF-15/3/20/2 x 3 M | 192018656 | 2 x 700 | 2 x 0.6 | • | – | • | 20 | 1.5 kW - 400 V - 3 Ph |
| PMF-15/3/20/2 x 3 E | – | 2 x 700 | 2 x 0.6 | – | • | – | 20 | 1.5 kW - 400 V - 3 Ph |
| PMF-15/3/40/4 x 3 M | N12300924 | 4 x 700 | 4 x 0.3 | • | – | • | 40 | 1.5 kW - 400 V - 3 Ph |
| PMF-15/3/40/4 x 3 E | N12300003 | 4 x 700 | 4 x 0.3 | – | • | – | 40 | 1.5 kW - 400 V - 3 Ph |
| PMF-30/3/40/4 x 3 M | N12300007 | 4 x 700 | 4 x 0.6 | • | – | • | 40 | 3.0 kW - 400 V - 3 Ph |
| PMF-30/3/40/4 x 3 E | N12300005 | 4 x 700 | 4 x 0.6 | – | • | – | 40 | 3.0 kW - 400 V - 3 Ph |
| PMF-55/3/100/4 x 3 E | – | 4 x 700 | 4 x 1.0 | – | • | – | 100 | 5.5 kW - 400 V - 3 Ph |
| PMF-110/3/100/4 x 3 E | – | 4 x 700 | 4 x 2.1 | – | • | – | 100 | 11.0 kW - 400 V - 3 Ph |

INFO

All multiple-flow power packs are also available with 4-way directional valves in order to operate double-acting hydraulic cylinders model PMF.



This port can easily be used to connect a pressure gauge and a pressure relief valve (e.g. VPR-1). The oil port T shall always be connected to the reservoir without any back pressure.

VHP und VHH Directional valves

Manually operated, 700 bar

These directional valves control the oil flow in combination with hydraulic power packs (YHH-4/3 with hand pumps).

All valves have 3 lever positions to control movement of the connected hydraulic cylinder:

1. left: cylinder advance.
2. middle: cylinder neutral (pressureless circuit).
3. right: cylinder retracts.

In the middle position (hold) the piston of the cylinder stops and the oil flow is guided in a circuit back to the reservoir (P to T). The valves can be flanged directly onto power packs but can also be connected by using hydraulic piping.

In addition, all valves are equipped with a second pressure oil port P at the back of the valve base.

Technical data VHP and VHH

| Model | Art.-No. | Pressure max. l/min | Size | Oil ports | Hydraulic symbol | Applications |
|--------------|-----------|---------------------|----------------------|-----------|------------------|---|
| VHP-3/3-1 | N14100718 | 8 - 16 | 1 | 3/8 NPT | | 3/3-way valve with "open centre" in middle position (pressureless circuit) to control single-acting hydraulic cylinders |
| VHP-3/3-2 | N14100720 | 20 - 40 | 2 | 3/8 NPT | | |
| VHP-3/3-1 CC | N14100719 | 8 - 16 | 1 | 3/8 NPT | | 3/3-way valve with "closed centre" in middle position to control single-acting hydraulic cylinders |
| VHP-3/3-2 CC | N14100721 | 20 - 40 | 2 | 3/8 NPT | | |
| VHP-4/3-1 | N14100227 | 8 - 16 | 1 | 3/8 NPT | | 4/3-way valve with "open centre" in middle position (pressureless circuit) to control double-acting hydraulic cylinders |
| VHP-4/3-2 | N14100228 | 20 - 40 | 2 | 3/8 NPT | | |
| VHP-4/3-1 CC | N14100322 | 8 - 16 | 1 | 3/8 NPT | | 4/3-way valve with "closed centre" in middle position to control double-acting hydraulic cylinders |
| VHP-4/3-2 CC | N14100335 | 20 - 40 | 2 | 3/8 NPT | | |
| VHH-4/3 | N14100226 | 2 - 3 | small special design | 1/4 NPT | | 4/3-way valve with "open centre" in middle position (pressureless circuit) to control double-acting hydraulic cylinders. Special design to be mounted directly to all HPS hand pumps (with connecting set FY-703). Also suitable for small hydraulic power packs. |

VEP

Directional valves

Solenoid incl. pressure set valve, 700 bar

Solenoid operated valves are used to control the connected hydraulic cylinder by means of a pendant remote control or further electrical controls like pressure switches or limit switches.

Control principle

All solenoid valves have 3 positions:

– advance – hold – return –

In neutral position (stop) the valves switch to “pressure-less circuit” so that the oil flow is guided back to the reservoir while the connected cylinder is safely held under pressure.

Normally, solenoid valves are mounted directly onto power packs but can also be connected by using hydraulic piping.

Design

Long-life, direct-control ball seal valves with leak-free “load hold function” in neutral position.

The solenoids guarantee a very quick reaction of the valves so that cylinders can be controlled millimeterwise.

The valves are suitable for continuous operation (100% on/off duration).

Modular design

The modular principle allows special valve configurations e.g. control of multiple cylinder systems or specific control sequences.

Pressure adjustment

All solenoid valves are equipped with a precision-adjustable pressure set valve which allows the system pressure (force of cylinder) to be limited to any value from 0 to 700 bar.



VEP-3/3-1

VEP-4/3-1

Pressure gauge

A glycerine-damped pressure gauge GGY-631 is standard with solenoid valves, 0 - 1000 bar, Ø 63 mm.

Mounting flange

The valve flanges are designed in a way that valves (with pressure connector) can easily be mounted onto power packs.

Option

The connector model FY-905 is to be ordered separately.

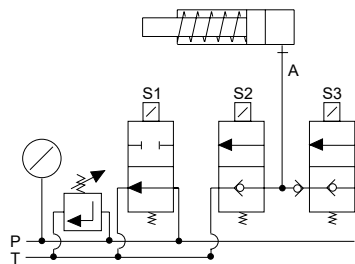

VEP-3/3-1 and VEP-3/3-2 for single-acting cylinders

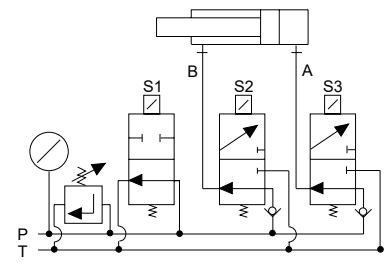

VEP-4/3-1 and VEP-4/3-2 for double-acting cylinders

INFO

If oil ports A and B should have 3/8 NPT the adaptor model FY-30 is to be ordered separately.

Technical data VEP

| Model | Art.-No. | Control | For cylinders | Operating pressure max. bar | Size | Oil flow max. l/min | Control voltage | Oil ports P T | Pressure relief valve | Weight kg |
|-----------|-----------|---------|---------------|-----------------------------|------|---------------------|-----------------|---------------|-----------------------|-----------|
| VEP-3/3-1 | N14100404 | 3/3-way | single-acting | 700 | 1 | 12 | 24 V = | 3/8 NPT | yes | 4.1 |
| VEP-3/3-2 | N14100405 | 3/3-way | single-acting | 700 | 2 | 25 | 24 V = | 3/8 NPT | yes | 7.9 |
| VEP-4/3-1 | N14100403 | 4/3-way | double-acting | 700 | 1 | 12 | 24 V = | 3/8 NPT | yes | 4.1 |
| VEP-4/3-2 | N14100406 | 4/3-way | double-acting | 700 | 2 | 25 | 24 V = | 3/8 NPT | yes | 7.9 |



Selection advice

If the valve is to be screwed directly into a hydraulic cylinder, please order model VSM-11.

If the valve is to be combined with the directional valve of a power pack, please order model VSM-21. (see picture on page 380).

VSM Safety-check valves

700 bar

These safety-check valves are used for those applications where pressure drops must be avoided (e.g. holding of a lifted load). Depending on the location in a hydraulic circuit, these valves can have different functions.

The model VSM-11 can be directly screwed into the oil port of a hydraulic cylinder and works at this location as a "hose break fuse". The design of the VSM-21 is suitable for a combination with VHP directional valves.

At this location the VSM-21 ensures that the pressure is held precisely and that pressure drops caused by operating the directional valve are avoided.

Operation

After closing the relief valve (hand wheel) the cylinder can be advanced via the by-pass. In direction to the cylinder the valves always have free flow. The built-in check valve ensures that a pressurized cylinder (e.g. a lifted load) is held precisely in stop position.

A smooth lowering speed can be adjusted by opening the throttle valve (hand wheel) in order to relieve the pressure.

A safety pressure valve protects the cylinder from being overloaded by external loading.

Technical data VSM

| Model | Art.-No. | Operating pressure max. bar | Control | Oil-port cylinder side A | Oil-port pump side B | Width mm | Weight kg |
|--------|-----------|-----------------------------|-------------|--------------------------|----------------------|----------|-----------|
| VSM-11 | N14100921 | 700 | Check valve | 3/8-18 NPT outer | 3/8-18 NPT inner | 6 | 0.9 |
| VSM-21 | N14100972 | 700 | Check valve | 3/8-18 NPT inner | 3/8-18 NPT outer | 6 | 1.0 |

Dimensions VSM (housing incl. hand wheel)

| Model | VSM-11 | VSM-21 |
|------------|--------|--------|
| Length, mm | 65 | 65 |
| Width, mm | 60 | 60 |
| Height, mm | 110 | 110 |

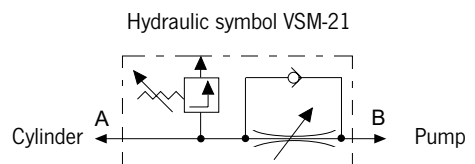

VHM Throttle-/Shut-off valves

700 bar

These valves are used to shut-off hydraulic lines especially in multiple cylinder systems. The needle valve VHM-1 also allows to throttle an oil flow especially in connection with lifting applications.



VHM-1-E



VHM-2

Technical data VHM

| Model | Art.-No. | Operating pressure max. bar | Control | Oil ports both ends | Width mm | Weight kg |
|---------|-----------|-----------------------------|---------|---------------------|----------|-----------|
| VHM-1-E | N14101313 | 700 | Needle | 3/8-NPT inner | 4 | 0.7 |
| VHM-2 | N14100344 | 700 | Ball | 3/8-NPT inner | 6 | 0.9 |

Dimensions VHM

| Model | VHM-1-E | VHM-2 |
|------------|---------|-------|
| Length, mm | 70 | 75 |
| Width, mm | 30 | 45 |
| Height, mm | 80 | 75 |

Hydraulic symbol

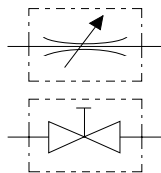

VPS Pressure switch

Adjustable between 100 - 800 bar

As soon as the pressure has reached the set value, a micro-switch (altering contact) is activated.

This signal can be used:

- For automatic pressure limiting.
- To report a certain pressure value.
- As an automatic motor on/off switch with pressure guard power packs.



Technical data VPS

| Model | Art.-No. | Control range bar | Electric data | Oil ports | Difference of switch point bar | Repeat accuracy bar | Weight kg |
|-------|-----------|-------------------|---------------|-----------|--------------------------------|---------------------|-----------|
| VPS-1 | N14100639 | 100 - 800 | 5 A/250V | 3/8 NPT | 25 - 70 | 10 | 0.5 |

Dimensions VPS

| Model | VPS-1 |
|--------------------|----------|
| Height x width, mm | 130 x 85 |

Hydraulic symbol

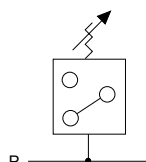

As soon as the pressure has reached the set value, a micro-switch (alternating contact) is activated. Should the pressure drop, the micro-switch starts the pump again in order to rebuild the pressure.



VPR Pressure relief valves

0 - 700 bar

Pressure relief valves are used if the system pressure (force of the connected hydraulic cylinder) should not exceed a certain value. These precision valves can be easily adjusted and are characterized by precise repetition. The question of a pressure relief valve only depends on the displacement of the high pressure stage of the power pack.

After achieving the set pressure value, the excessive oil is guided back to the reservoir (pressureless).

Technical data VPR

| Model | Art.-No. | Control range bar | Oil ports P | Oil ports T | Oil flow max. l/min | Weight kg |
|-------|-----------|-------------------|-------------|-------------|---------------------|-----------|
| VPR-1 | N14100722 | 0-700 | G 3/8 | G 1/4 | 10 | 0.8 |

Dimensions VPR

| Model | VPR-1 |
|------------|-------|
| Length, mm | 120 |
| Ø, mm | 40 |

Hydraulic symbol

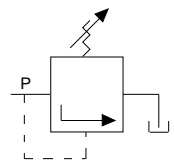

**MY
Manifolds**

700 bar

Manifolds are used when several hydraulic cylinders have to be connected to one hydraulic pump. All manifolds are equipped with 3/8 NPT inner oil ports, so that fittings, hydraulic hoses and couplers can easily be attached.

To connect a manifold directly to a hand pump a FY-1 double nipple is recommended.

Each manifold is supplied with three steel blind plugs in case not all the oil ports are required.



Technical data MY

| Model | Art.-No. | Oil ports | Weight kg |
|-------|-----------|-------------------|-----------|
| MY-1 | N14100164 | 6 x 3/8-NPT inner | 0.5 |
| MY-2 | N14100247 | 4 x 3/8-NPT inner | 0.6 |
| MY-4 | N14100198 | 7 x 3/8-NPT inner | 1.4 |

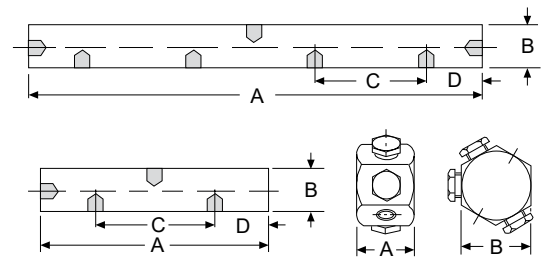

Dimensions MY

| Model | MY-1 | MY-2 | MY-4 |
|-------|------|------|------|
| A, mm | 40 | 150 | 330 |
| B, mm | 50 | 40 | 40 |
| C, mm | - | 90 | 90 |
| D, mm | - | 30 | 30 |



MY Manifolds

With shut-off valve, 700 bar

Manifolds with shut-off valves are used when different pressures must be maintained in each hydraulic line and therefore allow the lifting of unequal loads. The manifolds are fully assembled and can be screwed directly to a hand pump or power pack. Depending on the way of assembly a short hose HHC-10 and a coupler half CFY-1 can be helpful.

Manifolds models MY ... GYA are equipped with the corresponding number of shut-off valves plus pressure gauge sets (GYA-63) which allow a permanent reading of each individual load.

Technical data MY

| Model | Art.-No. | Version | Weight kg |
|-----------|-----------|---|-----------|
| MY-22 | N14100503 | 2-way manifold with 2 shut-off valves | 1.8 |
| MY-44 | N14100504 | 4-way manifold with 4 shut-off valves | 3.7 |
| MY-66 | N14101056 | 6-way manifold with 6 shut-off valves | 5.5 |
| MY-22-GYA | N14101024 | 2-way manifold with 2 shut-off valves and 2 pressure gauges | 2.8 |
| MY-44-GYA | N14101025 | 4-way manifold with 4 shut-off valves and 4 pressure gauges | 5.7 |
| MY-66-GYA | N14101057 | 6-way manifold with 6 shut-off valves and 6 pressure gauges | 8.5 |

Assembly examples:



Hand pump
HPS-2/2 A with MY-44



Electric hydraulic pump
PY-07/3/20/3 M with VSM-21 and MY-44

HPK-10 Transportation box

For hand pumps, hydraulic cylinders and accessories

For easy transportation and protection of your valuable tools. Large enough to take a hand pump with pressure gauge and hydraulic hose plus several hydraulic cylinders.

The sturdy sheet metal box is equipped with a solid handle and two clasps.

HPK-10

Dimensions (L x W x H): 800 x 300 x 170 mm,
weight: approx. 7.8 kg.



HFY Hydraulic oil

For all hand pumps and power packs

The high quality of the Yale hydraulic oil guarantees a long service life for your equipment.

The high grade HLP oil comes as follows:

Features

- Class of viscosity ISO VG 32.
- High lubrication index.
- High pressure resistance
- Favourable temperature/viscosity index.
- Protection against corrosion and cavitation.
- Minimizes the formation of foam and sludge.
- Good derivation of temperature.
- No aging problems
- Good compatibility with all sealing materials.
- Fulfills all requirements of DIN 51524 part 2.



Technical data HFY

| Model | Art.-No. | Content l |
|--------|-----------|--------------|
| HFY-1 | N14300194 | 1 |
| HFY-5 | N14300195 | 5 |
| HFY-10 | N14301061 | 10 |
| HFY-20 | N14301062 | 20 |



GGY

Pressure gauges

The use of pressure gauges is recommended when the operating pressure (the force of the connected cylinder) should be monitored. Yale pressure gauges are equipped with a stainless steel housing and an acrylic plastic face cover plate.

To absorb pressure shocks gauges are glycerine-filled, thus contributing to a long service life. Also, when fitted to a motor pump, the pointer will stay jitterfree.

For the calculation of applied cylinder forces corresponding converting charts (pressure vs. force) can be supplied for all Yale hydraulic cylinders free of charge.

Technical data GGY

| Model | Art.-No. | Pressure range bar | Scale diameter mm | Glycerine- damped | Oil port DIN 16288 | Spanner size | Accuracy class % |
|--------------------------|-----------|-----------------------|-------------------------|----------------------|-----------------------|-----------------|------------------------|
| GGY-631 | N14100168 | 0 - 1000 | 63 | yes | G 1/4 | 14 | 1.6 |
| GGY-632 | N14100663 | 0 - 1000 | 63 | yes | 1/4 NPT | 14 | 1.6 |
| GGY-633 | N14100877 | 0 - 160 | 63 | yes | G 1/4 | 14 | 1.6 |
| GGY-634 | N14100878 | 0 - 250 | 63 | yes | G 1/4 | 14 | 1.6 |
| GGY-635 | N14100879 | 0 - 400 | 63 | yes | G 1/4 | 14 | 1.6 |
| GGY-636 | N14100880 | 0 - 600 | 63 | yes | G 1/4 | 14 | 1.6 |
| GGY-1001 | N14100169 | 0 - 1000 | 100 | yes | G 1/2 | 22 | 1.0 |
| GGY-1001 SZ ¹ | N14100698 | 0 - 1000 | 100 | yes | G 1/2 | 22 | 1.0 |
| GGY-1002 | N14100664 | 0 - 250 | 100 | yes | G 1/2 | 22 | 1.0 |
| GGY-1003 | N14100696 | 0 - 400 | 100 | yes | G 1/2 | 22 | 1.0 |
| GGY-1004 | N14100697 | 0 - 700 | 100 | yes | G 1/2 | 22 | 1.0 |
| GGY-1005 | N14101023 | 0 - 160 | 100 | yes | G 1/2 | 22 | 1.0 |
| GGY-2500 | N14100658 | 0 - 2500 | 100 | yes | G 1/2 | 22 | 1.6 |

¹GGY-1001 SZ = with maximum pointer



GYA-63

Pressure gauge set

Consisting of pressure gauge GGY-632 (diameter Ø 63 mm, glycerine-damped) and corresponding gauge adaptor. This pressure gauge set is suitable for connection to all HPS hand pumps.

Assembled ready to use, compact design with 45° inclination for easy reading.

Technical data GYA-63

| Model | Art.-No. | Pressure gauge bar | Oil port pump | Oil port hose | Weight kg |
|--------|-----------|---|---------------|---------------|--------------|
| GYA-63 | N14200497 | 0 - 1000 bar, Ø 63 mm, glycerine-damped | 3/8-NPT outer | 3/8-NPT inner | 0.5 |

GA
Pressure gauge adaptor

Gauge connection with sleeve nut and 30° inclination for easy reading.

Suitable for all hand pumps series HPS.



Technical data GA

| Model | Art.-No. | Oil port gauge | Oil port pump | Oil port hose |
|--------|-----------|----------------|---------------|---------------|
| GA-700 | N14200201 | G 1/4 | 3/8-NPT outer | 3/8-NPT inner |
| GA-701 | N14200208 | G 1/2 | 3/8-NPT outer | 3/8-NPT inner |

GA
Pressure gauge adaptor set

For double-acting hand pumps model HPH, for mounting between 4/3-directional valve and hand pump.

Features

- Advantage: shows both the pushing force and the pulling force of the connected hydraulic cylinder.
- 30° inclination for easy reading.
- Pressureless return line by means of telescopic double nipple.



Technical data GA

| Model | Art.-No. | Oil port gauge | Oil port | Telescopic nipple |
|--------|-----------|----------------|-------------------|-------------------|
| GA-703 | N14200202 | G 1/2 | 2 x 3/8-NPT outer | 2 x 1/4-NPT outer |
| GA-704 | N14200640 | G 1/4 | 2 x 3/8-NPT outer | 2 x 1/4-NPT outer |

GA-2000
Pressure gauge adaptor

This pressure gauge adaptor is suitable for connection to all TWAZ hand pumps (2000 bar). Suitable for pressure gauge GGY-2500.



Technical data GA-2000

| Model | Art.-No. | Operating pressure max. bar | Oil port gauge | Oil port pump | Oil port hose |
|---------|-----------|-----------------------------|----------------|----------------------------------|--------------------------------|
| GA-2000 | N14200419 | 2000 | G 1/2 | M22 x 1.5 outer (with seal cone) | M22 x 1.5 innen (for FY - 201) |



CFY, CMY, CCY Hydraulic couplers

Yale hydraulic couplers are self-sealing which means that the coupler halves only have to be closed hand-tight. Both female and male parts have inner balls which seal the coupler halves in uncoupled condition, so that no hydraulic fluid will leak.

Please note that all Yale hydraulic cylinders are equipped with the standard female coupler half CFY-1 and dust cap CDF-9.

Technical data CFY, CMY and CCY

| Model | Art.-No. | Description | Pressure max. bar | Pressure max. bar |
|--------------------|-----------|---------------------------------|-------------------|-------------------|
| CFY-1 | N14200166 | Coupler half, female (standard) | 3/8-NPT, outer | 700 |
| CFY-2 | N14200482 | Coupler half, female | 3/8-NPT inner | 700 |
| CFY-18 | N14200420 | Coupler half, female | M18 x 1.5 outer | 700 |
| CFY-10-S | N14200814 | Coupler half, female | Pipe Ø 10 mm | 700 |
| CMY-1 | N14200167 | Coupler half, male | 3/8-NPT, inner | 700 |
| CCY-1 | N14200165 | Coupler halves, female + male | 3/8-NPT | 700 |
| CDF-9 ¹ | N14200396 | Dust cap, rubber | - | - |

¹fits to female and male coupler halves (standard with all female coupler halves)

Dimensions CFY, CMY and CCY

| Model | CFY-1 | CFY-2 | CFY-18 | CFY-10-S | CMY-1 | CCY-1 |
|-------|-------|-------|--------|----------|-------|-------|
| A, mm | - | - | - | - | - | 87 |
| B, mm | 72 | 78 | 72 | 72 | - | - |
| C, mm | - | - | - | - | 40 | - |
| D, mm | 35 | 35 | 35 | 35 | - | - |
| E, mm | 14 | 27 | 24 | 24 | - | - |
| F, mm | - | - | - | - | 32 | - |

INFO

Hydraulic couplers must always be completely closed, since otherwise the circulation cannot be released.

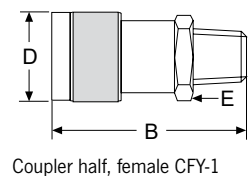
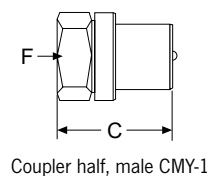
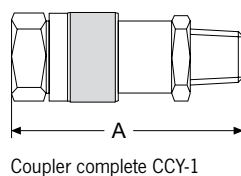

HHC Hydraulic hoses

Durable but highly flexible thermoplast hydraulic hoses guarantee a very long life.

The 4-layer build-up includes 2 layers of high tensile steel fabric and robust fitting with 19 mm hexagon.

The volumetric expansion is very low. Hydraulic hoses model HHC are equipped with a male coupler half as standard.

Standard length are as per the chart below, further lengths or hoses with larger diameters are quoted on request.



Technical data HHC

| Model | Art.-No. | Length m | Operating pressure bar | Burst pressure bar | Connection 2 male coupler half CMY-1 | Connection 1 thread nipple 3/8-NPT, outer | External diameter approx. mm | Bend radius min. mm | Width mm |
|---------|-----------|-------------|---------------------------|-----------------------|---|--|------------------------------------|---------------------------|-------------|
| HHC-5 | N14200330 | 0.5 | 700 | 2800 | | | 14 | 100 | 6.3 |
| HHC-10 | N14200300 | 1 | 700 | 2800 | | | 14 | 100 | 6.3 |
| HHC-20 | N14200151 | 2 | 700 | 2800 | | | 14 | 100 | 6.3 |
| HHC-30 | N14200331 | 3 | 700 | 2800 | | | 14 | 100 | 6.3 |
| HHC-40 | N14200152 | 4 | 700 | 2800 | | | 14 | 100 | 6.3 |
| HHC-60 | N14200209 | 6 | 700 | 2800 | | | 14 | 100 | 6.3 |
| HHC-80 | N14200313 | 8 | 700 | 2800 | | | 14 | 100 | 6.3 |
| HHC-100 | N14200332 | 10 | 700 | 2800 | | | 14 | 100 | 6.3 |
| HHC-120 | N14200702 | 12 | 700 | 2800 | | | 14 | 100 | 6.3 |
| HHC-150 | N14200703 | 15 | 700 | 2800 | | | 14 | 100 | 6.3 |

How to order

Hydraulic hose for all standard combinations (– pump – hose – cylinder –):

Order a standard hose with female coupler half model HHC-... (e.g. HHC-20).

Hydraulic hose for coupling connections on both sides (both ends with CMY-1):

Order a complete coupler CCY-1 in addition to a standard hose HHC-... (recommended for long hydraulic hoses).

Hydraulic extension hose (one male coupler half, one female coupler half):

Order a female coupler half CFY-2 (inner thread) in addition to a standard hose model HHC-...

Hydraulic hose without any coupler parts (both ends with threaded nipples):

Order model HH-... (both ends 3/8-NPT outer).











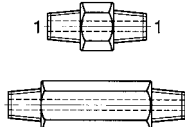

FY Fittings, reducers, connectors

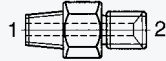
Fittings are useful for versatile combinations of hydraulic cylinders.

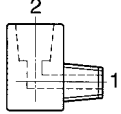

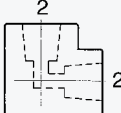

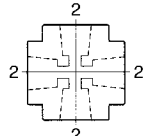

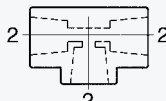



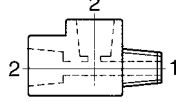

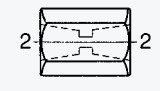

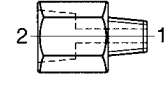

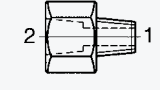
Yale high pressure fittings have been designed to give a variety of connections, extensions and combinations. The fittings are designed for a max. system pressure of 700 bar.

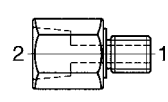
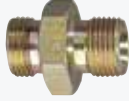
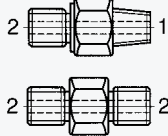
For improved sealing of 3/8 NPT connections use two layers of teflon tape and tighten accordingly.

Technical data FY

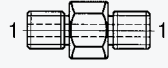
| Model | Art.-No. | | Description | Figures | Connection 1 | Connection 2 |
|-------------------------|-------------------------------------|---|--------------------------------------|---|---|--|
| FY-1 FY-1L | N14200153 N14200659 |  | Double nipple Double nipple, long |  | 3/8 NPT outer 3/8 NPT outer | - - |
| FY-13 FY-17 FY-18 | N14200244 N14200342 N14200343 |  | Double nipple |  | 1/4 NPT outer 3/8 NPT outer 3/8 NPT outer | R 1/4 outer M14 x 1.5 (for sleeve nut) R 1/4 outer |
| FY-2 | N14200154 |  | Elbow |  | 3/8 NPT outer | 3/8 NPT inner |
| FY-3 | N14200155 |  | Elbow |  | - | 3/8 NPT inner |
| FY-6 | N14200158 |  | Cross |  | - | 3/8 NPT inner |
| FY-4 | N14200156 |  | Tee |  | - | 3/8 NPT inner |

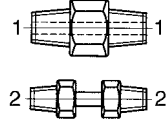
Technical data FY

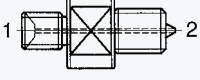
| Model | Art.-No. | | Description | Figures | Connection 1 | Connection 2 |
|---|---|---|--|--|---|---|
| FY-5 | N14200157 |  | Tee |  | 3/8 NPT outer | 3/8 NPT inner |
| FY-7 FY-11 | N14200159 N14200243 |  | Connection |  | - | 3/8 NPT inner 1/4 NPT inner |
| FY-8 FY-9 | N14200199 N14200224 |  | Adaptor |  | 3/8 NPT outer 1/4 NPT outer | R 1/2 inner 3/8 NPT inner |
| FY-10 FY-12 | N14200245 N14200246 |  | Adaptor |  | 3/8 NPT outer 1/2 NPT outer | 1/4 NPT inner 3/8 NPT inner |
| FY-16 FY-19 FY-20 FY-30 FY-33 | N14200323 N14200353 N14200354 N14200693 N14200889 |  | Adaptor |  | 3/8 NPT outer M18 x 1,5 outer M14 outer G 3/8 outer 3/8 NPT outer | M18 x 1,5 inner 3/8 NPT inner 3/8 NPT inner 3/8 NPT inner M14 x 1.5 inner |
| FY-26 FY-27 | N14200654 N14200655 |  | Double nipple |  | 3/8 NPT outer G 3/8 outer | G 3/8 outer G 3/8 outer |
| FY-31 FY-32 | N14200694 N14200695 |  | Connection |  | 3/8 NPT inner 3/8 NPT inner | M18 x 1.5 inner M20 x 1.5 inner |
| FY-35 | N14200890 |  | Double nipple |  | M 14 outer | - |
| FY-703 | N14200203 |  | Connecting set for 4/3-way valve to HPS hand pumps (telescopic nipple) |  | 3/8 NPT outer | 1/4 NPT outer |
| FY-201 | N14200487 |  | Adaptor for TWAZ hand pumps 2000 bar |  | R1/4 outer | M22 x 1.5 outer (with seal cone) |



BMZ Hydraulic puller with integrated hydraulics

Pulling force max. 6, 8 and 11 t

Hydraulic pullers are a valuable tool for the maintenance engineer. The pullers allow time and cost savings as they offer high working safety and can be operated in all positions. Hydraulic pullers are used in all kinds of industries, workshops and in many repair and assembly jobs to remove or install interference fit parts, such as: gears, couplings, bearings, wheels, pulleys, axles, shafts, break drums and many other press fit components. Damage to parts is minimized through the use of controlled hydraulic power, whilst machine down-time can be reduced drastically.

Features

- Drop-forged alloy steel jaws.
- Hard chromium plated piston, spring return.
- No radial moment of torsion.
- No spindle wear.
- Integrated hydraulic cylinder and pump.
- Quick adjustment with trapezoid speed nut.
- 3 and 2-jaw design.
- Pump lever can rotate through 360°.
- Piston with durable, spring loaded centering tip.
- Supplied in a sturdy plastic box.

Technical data BMZ

| Model | Art.-No. | Pulling force max. t | Stroke mm | Weight kg |
|--------|-----------|----------------------|-----------|-----------|
| BMZ-6 | N13500610 | 6 | 82 | 4.9 |
| BMZ-8 | N13500611 | 8 | 82 | 6.6 |
| BMZ-11 | N13500612 | 11 | 82 | 8.0 |

Dimensions BMZ

| Model | BMZ-6 | BMZ-8 | BMZ-11 |
|--------------------|-------|-------|--------|
| Reach max. A, mm | 160 | 200 | 230 |
| Width Ø max. B, mm | 200 | 250 | 280 |
| Length C, mm | 320 | 320 | 345 |

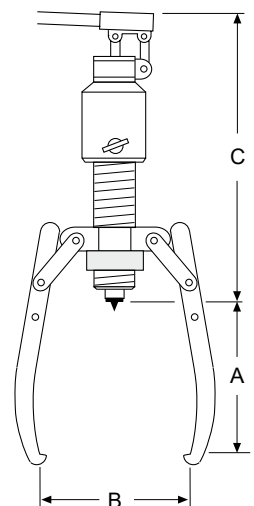





BMZ-1010
BMZ-1510



BMZ-2311

BMZ Puller sets with separate hydraulics 10, 15 and 23 t

Pulling force max. 10 - 23 t

The harder the pulling force, the tighter the grip of the jaws. Longer jaws up to 1000 mm are available on request.

Features

- High quality components from our standard hydraulic programme.
- Modular system, hydraulic parts can also be used for many other applications.
- Long-life hydraulic cylinders manufactured from chromium-molybdenum steel.
- Two-stage quick-action hand pumps.
- Incl. high pressure hydraulic hose with quick coupler, L = 2.0 m.
- All complete sets are supplied in metal box model HPK-10 or wooden case.
- All sets are supplied ready to use.

Scope of delivery

- Pressure gauge set model GYA-63.



Accessories for BMZ-2300 and BMZ-2311: BMZ-2308 extensions of pulling arms increase the reach (A) up to 395 mm. BMZ-2309 up to 495 mm.



Pressure gauge set GYA-63 is part of the scope of delivery.

BMZ-1010 and 1510

The harder the pulling force, the tighter the grip of the jaws. Longer jaws up to 1000 mm are available on request.

BMZ-2311

The radially adjustable pulling arms can be locked in any position.

Technical data BMZ

| Model | Art.-No. | Pulling force max. t | Hydraulic cylinder model | Hand pump model | Hydraulic hose model | Stroke of the cylinder mm | Weight kg |
|----------|-----------|----------------------|--------------------------|------------------|----------------------|---------------------------|-----------|
| BMZ-1000 | N13500613 | 10 | without | without | without | - | 9.5 |
| BMZ-1010 | N13500614 | 10 | with YS-10/150 | with HPS-2/0,7 A | HHC-20 | 150 | 21.5 |
| BMZ-1500 | N13500615 | 15 | without | without | without | - | 9.5 |
| BMZ-1510 | N13500616 | 15 | with YS-15/150 | with HPS-2/0,7 A | HHC-20 | 150 | 23.5 |
| BMZ-2300 | N13500617 | 23 | without | without | without | - | 56.8 |
| BMZ-2311 | N13500600 | 23 | with YS-23/160 | with HPS-2/0,7 A | HHC-20 | 160 | 106.0 |

Dimensions BMZ

| Model | BMZ-1000 | BMZ-1500 | BMZ-2300 |
|--------------------|----------|----------|----------|
| Reach max. A, mm | 300 | 300 | 190 |
| Width Ø max. B, mm | 350 | 350 | 700 |

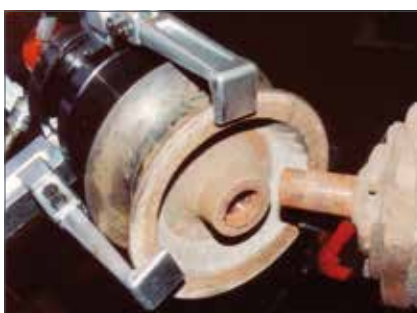
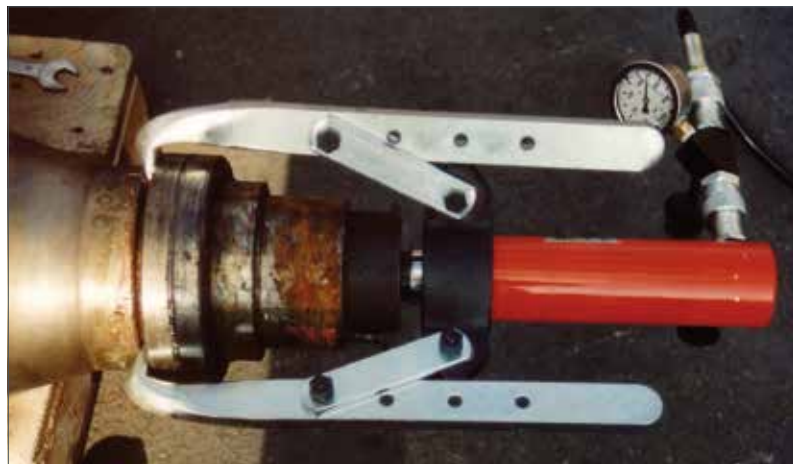
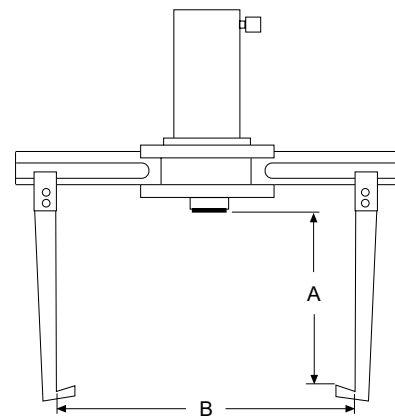
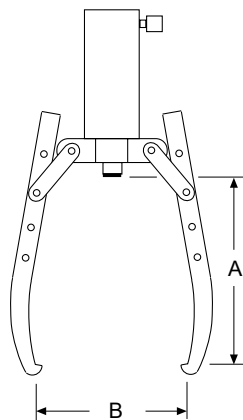

INFO

The set "Cross-bearing puller" have reduced max. pulling forces.



3-Grip puller sets

For all pulling jobs where solid parts have to be removed, e.g. gears, belt pulleys, sprockets, flywheels, couplers, shafts, axles etc. The sets can be used as both 3-jaw and 2-jaw puller.

| Model | Art.-No. | Pulling force max. t |
|-----------|-----------|-------------------------|
| YHP-252 G | N13500005 | 20 |
| YHP-352 G | N13500006 | 30 |
| YHP-552 G | N13500007 | 50 |



Cross-bearing puller sets

For all pulling jobs where multi-segmented parts have to be removed: ball bearings, roller bearings and similar parts. Puller sets are supplied complete with bearing puller attachment and bearing cup puller.

| Model | Art.-No. | Pulling force max. t |
|-----------|-----------|-------------------------|
| YHP-262 G | N13500008 | 10 |
| YHP-362 G | N13500009 | 15 |
| YHP-562 G | N13500010 | 25 |



Multi-purpose puller sets

These multi-purpose puller sets are universal combinations of both a.m. sets and include all necessary parts from 3-grip puller set and crosshead puller set.

| Model | Art.-No. | Pulling force max. t |
|------------|-----------|-------------------------|
| YHP-2752 G | N13500011 | 20/10 |
| YHP-3752 G | N13500012 | 30/15 |
| YHP-5752 G | N13500013 | 50/25 |

Type of puller set

| Model | 3-grip puller set | | | Crosshead puller set | | | Multi purpose puller set | | |
|---|-------------------|-----------|-----------|----------------------|-----------|-----------|--------------------------|------------|------------|
| | YHP-252 G | YHP-352 G | YHP-552 G | YHP-262 G | YHP-362 G | YHP-562 G | YHP-2752 G | YHP-3752 G | YHP-5752 G |
| Art.-No. | N13500005 | N13500006 | N13500007 | N13500008 | N13500009 | N13500010 | N13500011 | N13500012 | N13500013 |
| Nennkraft, t | 20 | 30 | 50 | 10 | 20 | 25 | 20/10 | 30/15 | 50/25 |
| Hand pump, model HPS-1/07 A (part 1) | • | • | – | • | • | – | • | • | – |
| Hand pump, model HPS-2/2 A (part 1) | – | – | • | – | – | • | – | – | • |
| Pressure gauge set, model GYA-63 (part 2) | • | • | • | • | • | • | • | • | • |
| Hydraulic hose, model HHC-20 (part 3) | • | • | • | • | • | • | • | • | • |
| Hollow cylinder (part 4), model | YCS-21/50 | YCS-33/60 | YCS-57/70 | YCS-21/50 | YCS-33/60 | YCS-57/70 | YCS-21/50 | YCS-33/60 | YCS-57/70 |
| Triple crosshead (part 5) | • | • | • | – | – | – | • | • | • |
| Double crosshead (part 6) | • | • | • | – | – | – | • | • | • |
| Grip arm, 3 pcs. (part 8) | • | • | • | – | – | – | • | • | • |
| Spindle (part 9) | • | • | • | • | • | • | • | • | • |
| Strap, 6 pcs. (part 10) | • | • | • | – | – | – | • | • | • |
| Strap screws + strap nuts, 6 pcs. (part 11) | • | • | • | – | – | – | • | • | • |
| Mounting screws, 2 pcs. (part 13a) | • | • | • | – | – | – | • | • | • |
| Mounting screws, 2 pcs. (part 13b) | – | – | – | • | • | • | • | • | • |
| Saddle with internal thread (part 14) | • | • | • | • | • | • | • | • | • |
| Smooth saddle (part 15) | • | • | • | • | • | • | • | • | • |
| Slotted crosshead (part 16) | – | – | – | • | • | • | • | • | • |
| Slide plate, 2 pcs. (part 17) | – | – | – | • | • | • | • | • | • |
| Nut, 2 pcs. (part 18) | – | – | – | • | • | • | • | • | • |
| Washer, 2 pcs. (part 19) | – | – | – | • | • | • | • | • | • |
| Pulling leg, short, 2 pcs. (part 20), mm | – | – | – | 280 | 255 | 455 | 280 | 255 | 455 |
| Pulling leg, long, 2 pcs. (part 21), mm | – | – | – | 460 | 505 | 773 | 460 | 505 | 773 |
| Leg end, 2 pcs. (part 24) | – | – | – | • | • | • | • | • | • |
| Leg connector, 2 pcs. (part 25) | – | – | – | • | • | • | • | • | • |
| Bearing puller attachment (part 26) | – | – | – | • | • | • | • | • | • |
| Bearing cup pulling attachment (part 27) | – | – | – | • | • | • | • | • | • |
| Storage case (part 29) | • | • | • | • | • | • | • | • | • |
| Weight, kg | 40 | 65 | 120 | 46 | 86 | 156 | 91 | 172 | 295 |

The symbols stand for: • including complete set, – not included

Dimensions hydraulic puller set YHP

| Model | 20t | 30t | 50t |
|--------------|----------|----------|----------|
| 3-grip A, mm | 300 | 520 | 700 |
| C, mm | 0 - 817 | 0 - 977 | 0 - 1233 |
| 3-grip B, mm | 500 | 900 | 1200 |
| D, mm | 25 - 155 | 30 - 250 | 75 - 330 |
| 2-grip A, mm | 300 | 520 | 700 |
| E, mm | 152 | 250 | 330 |
| 2-grip B, mm | 420 | 700 | 1000 |
| F, mm | 140 | 150 | 150 |
| G, mm | 30 - 180 | 75 - 230 | 75 - 230 |

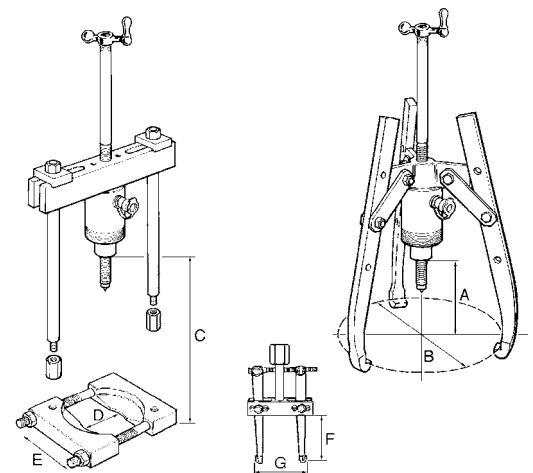



AJH-620

AJS-65

AJS-104

AJH und AJS

Aluminium hydraulic jacks

Capacity 6.5 - 100 t

Aluminium jacks combine light weight with high lifting capacity. The use of high tensile aluminium alloy allows lifting capacities of up to 100 tons resulting in a very favourable 1.8 tons lifting capacity per 1 kg weight ratio. Operation of Yale hydraulic jacks is very simple. Jacks are supplied ready for use, i.e. including hydraulic oil, operating lever and, where applicable, carrying handle and lifting claw.

Aluminium jacks with lifting claw

Jacks from 20 tons are available with a lifting claw. In this case the jacks are provided with an elongated base plate. The max. permissible working load of the lifting claws is 40% of the jack capacity.

Aluminium jacks with safety lock nut

Jacks from 20 tons can be supplied with a safety lock nut. This device allows absolute safe jacking over a long period. In this case the hydraulic jack can be operated like a mechanical support and the hydraulic system can be totally released.

Application

Hydraulic jacks are universally popular tools for use in workshops or on site for all kinds of lifting and assembly applications, for construction, shipbuilding, power plants, general engineering, metal fabrication and many more. Applications are unlimited. Standard jacks with plain piston and jacks with safety lock nuts cannot be used with a lifting claw. To increase stability, all jacks with long stroke (305 mm) are equipped with an elongated base plate.

Features

- Strokes from 75 - 305 mm.
- Extremely low weight.
- The 6.5 and 10 tons jacks can be operated in any position (also upside down) and are equipped with spring return piston and stop ring.
- The 20 to 100 tons jacks can be operated vertically or with front face in horizontal position.
- All jacks are provided with an overload protection valve.
- From 20 tons capacity with additional mechanical stroke limiter.
- All jacks with hardened alloy steel saddle and sensitive lowering valve which is activated by the operating lever.



AJH-630 SR

Technical data AJH and AJS

| Model | Art.-No. | Capacity t | Capacity of lifting claw max. t | Stroke mm | Overall height mm | Base plate mm | Height of lifting claw min. mm | Weight kg |
|----------|-----------|---------------|---------------------------------------|--------------|----------------------|------------------|--------------------------------------|--------------|
| AJS-65 | N13200950 | 6,5 | – | 75 | 131 | 159 x 76 | – | 3.6 |
| AJS-104 | N13200951 | 10 | – | 115 | 182 | 171 x 76 | – | 6.3 |
| AJH-620 | N13200952 | 20 | – | 152 | 265 | 180 x 120 | – | 10.9 |
| AJH-1220 | N13200955 | 20 | – | 305 | 440 | 250 x 120 | – | 16.7 |
| AJH-630 | N13200958 | 30 | – | 152 | 265 | 200 x 140 | – | 15.4 |
| AJH-1230 | N13200961 | 30 | – | 305 | 452 | 275 x 140 | – | 23.4 |
| AJH-660 | N13200964 | 60 | – | 152 | 293 | 250 x 190 | – | 27.4 |
| AJH-1260 | N13200967 | 60 | – | 305 | 500 | 340 x 190 | – | 43.7 |
| AJH-6100 | N13200970 | 100 | – | 152 | 315 | 305 x 250 | – | 49.0 |

Jacks with lifting claw

| Model | Art.-No. | Capacity t | Capacity of lifting claw max. t | Stroke mm | Overall height mm | Base plate mm | Height of lifting claw min. mm | Weight kg |
|------------|-----------|---------------|---------------------------------------|--------------|----------------------|------------------|--------------------------------------|--------------|
| AJH-620 C | N13200953 | 20 | 8 | 152 | 280 | 250 x 120 | 67 | 14.5 |
| AJH-1220 C | N13200956 | 20 | 8 | 305 | 452 | 250 x 120 | 67 | 22.2 |
| AJH-630 C | N13200959 | 30 | 12 | 152 | 284 | 275 x 140 | 72 | 20.3 |
| AJH-1230 C | N13200962 | 30 | 12 | 305 | 472 | 275 x 140 | 72 | 31.0 |
| AJH-660 C | N13200965 | 60 | 24 | 152 | 327 | 340 x 190 | 72 | 43.1 |
| AJH-1260 C | N13200968 | 60 | 24 | 305 | 533 | 340 x 190 | 72 | 64.9 |

Jacks with safety lock nut

| Model | Art.-No. | Capacity t | Capacity of lifting claw max. t | Stroke mm | Overall height mm | Base plate mm | Height of lifting claw min. mm | Weight kg |
|-------------|-----------|---------------|---------------------------------------|--------------|----------------------|------------------|--------------------------------------|--------------|
| AJH-620 SR | N13200954 | 20 | – | 152 | 291 | 180 x 120 | – | 10.9 |
| AJH-1220 SR | N13200957 | 20 | – | 305 | 464 | 250 x 120 | – | 16.7 |
| AJH-630 SR | N13200960 | 30 | – | 152 | 294 | 200 x 140 | – | 15.4 |
| AJH-1230 SR | N13200963 | 30 | – | 305 | 480 | 275 x 140 | – | 23.4 |
| AJH-660 SR | N13200966 | 60 | – | 152 | 330 | 250 x 190 | – | 27.4 |
| AJH-1260 SR | N13200969 | 60 | – | 305 | 536 | 340 x 190 | – | 43.7 |
| AJH-6100 SR | N13200971 | 100 | – | 152 | 366 | 305 x 250 | – | 53.0 |

Hydraulic Jacks & Tools

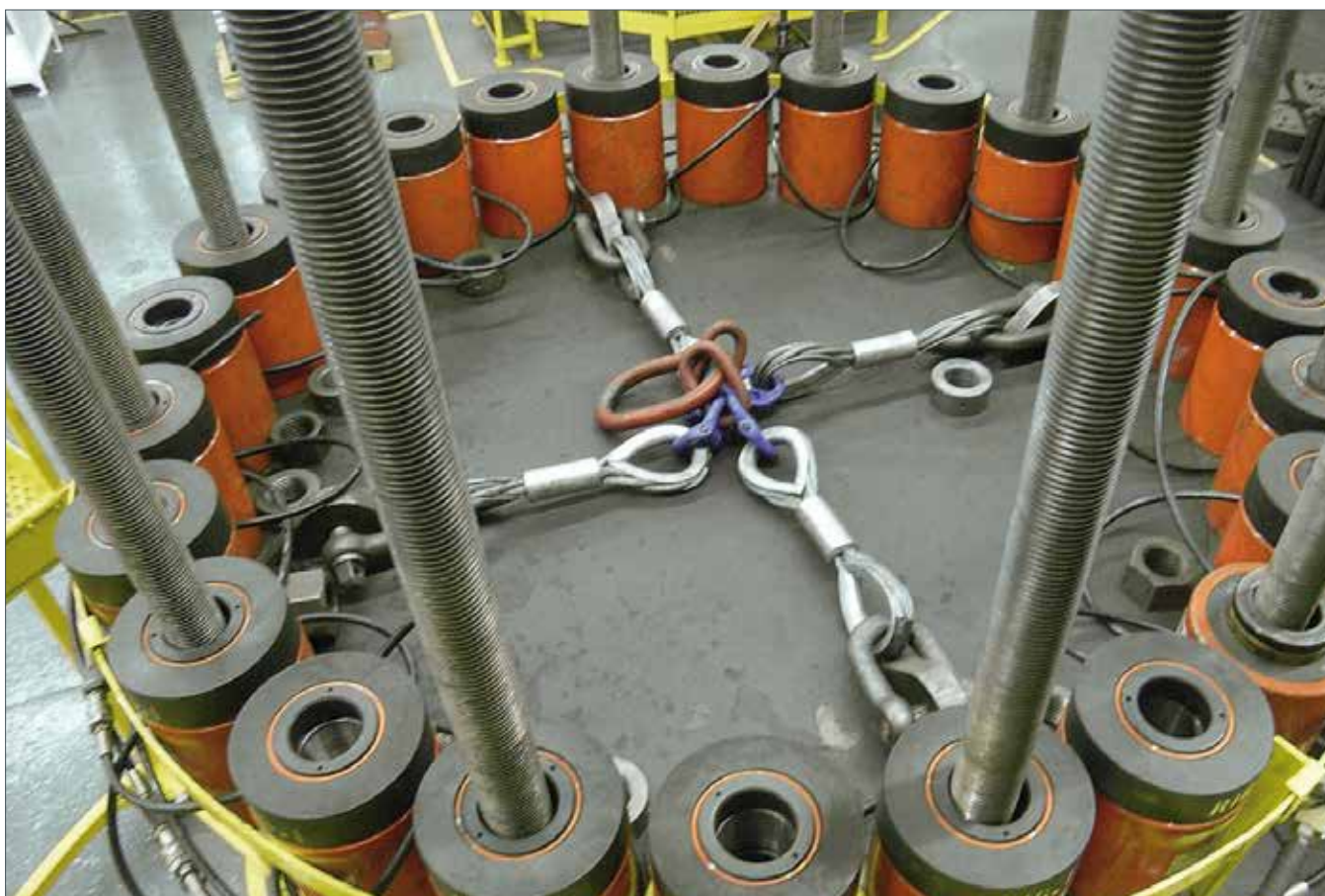

YAM

Machine jacks with lifting claw

Capacity 2 - 15 t

Machine jacks with lifting claw are used in applications where space below the load is restricted, thus preventing the use of traditional lifting equipment.

Typical applications for machine jacks are lifting, positioning and transportation of machines, heavy steel constructions or similar loads, as well as general repair and assembly applications.

The jacks are also useful for applications like leveling of high-rise warehouses, heavy-duty scaffolds, large frame-works etc.

Features

- Offers safe lifting of machines with an extremely low clearance.
- Incl. safety pressure valve to prevent overload.
- Large base offers increased stability under load.
- Pump lever can rotate through 270° (excluding YAM-2).
- Same load can be lifted on either the head or the claw of jack.
- Spring return of the lifting claw (only YAM-5 and YAM-10).
- Precision-adjustable lowering valve.
- Jacks are supplied ready to use incl. pump lever, and are filled with oil.



Technical data YAM

| Model | Art.-No. | Capacity on the claw t | Stroke mm | Weight kg |
|----------|-----------|------------------------|-----------|-----------|
| YAM-2 | N13100912 | 2 | 113 | 8 |
| YAM-5 | N13100627 | 5 | 120 | 19 |
| YAM-10 | N13100628 | 10 | 145 | 38 |
| YAM-15.1 | N13100914 | 15 | 140 | 53 |

Dimensions YAM

| Model | YAM-2 | YAM-5 | YAM-10 | YAM-15.1 |
|-------|-------|-------|--------|----------|
| A, mm | 235 | 290 | 325 | 344 |
| B, mm | 180 | 257 | 280 | 321 |
| C, mm | 125 | 182 | 240 | 258 |
| D, mm | 50 | 75 | 100 | 110 |
| E, mm | 50 | 57 | 60 | 60 |
| F, mm | 85 | 117 | 150 | 168 |
| G, mm | 16 | 26 | 33 | 33 |

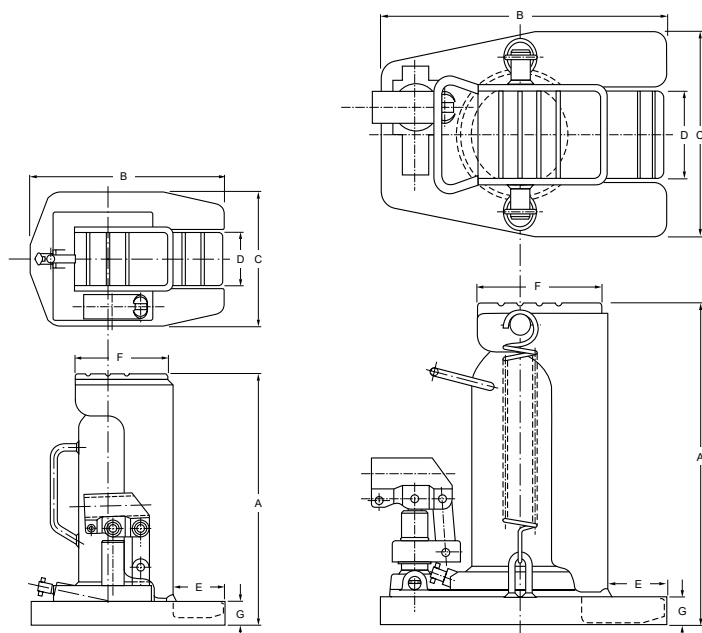



YAP Hydraulic machine jacks

Capacity 4.5 - 50 t

Hydraulic machine jacks are designed for the safe lifting and positioning of machines and similar heavy equipment.

Features

- These jacks are operated with external pumps, e.g. hand or motor pumps but also with synchronous power packs.
- The compact construction allows operation even in extremely confined areas.
- 3 hook-in positions of the lifting claw provide high flexibility (model YAP-5130 4 hook-in positions).
- The load can be lifted with either the lifting claw or with the head of the jack.
- Welded, distortion-proof steel construction.
- High quality, durable hydraulic components.
- The flat lifting claw allows low jacking height.
- Safe stability due to swivel-mounted support feet.
- The connection between jack and pump is made by a hydraulic hose.
- The jacks are delivered ready-to-use inclusive of carrying handles and coupling half.

Technical data YAP

| Model | Art.-No. | Capacity t | Stroke mm | Height for applications min. in mm | Pressure max. bar | Weight approx. kg |
|-----------|-----------|------------|-----------|------------------------------------|-------------------|-------------------|
| YAP-5130 | N13101114 | 4,5 | 133 | 15 | 700 | 13.5 |
| YAP-10150 | N13101115 | 10 | 155 | 20 | 700 | 23.0 |
| YAP-15150 | N13101116 | 15 | 155 | 25 | 700 | 40.0 |
| YAP-25150 | N13101117 | 23 | 155 | 30 | 700 | 60.0 |
| YAP-50150 | N13101118 | 50 | 155 | 35 | 700 | 165.0 |

Dimensions YAP

| Model | YAP-5130 | YAP-10150 | YAP-15150 | YAP-25150 | YAP-50150 |
|------------|----------|-----------|-----------|-----------|-----------|
| A min., mm | 15 | 20 | 25 | 30 | 35 |
| A max., mm | 232 | 273 | 291 | 300 | 375 |
| B, mm | 228 | 277 | 328 | 387 | 540 |
| H, mm | 252 | 283 | 316 | 330 | 405 |
| L, mm | 161 | 194 | 245 | 278 | 375 |

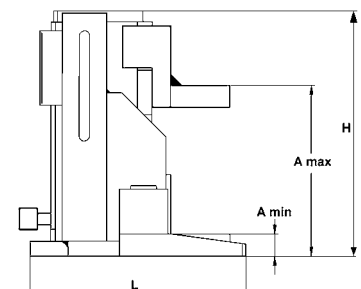
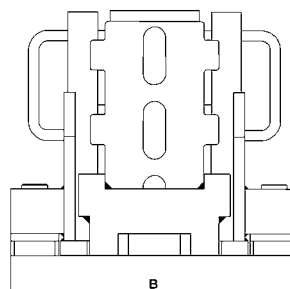

YAS

Hydraulic machine jacks

Capacity 3 - 25 t

Hydraulic machine jacks are designed for the safe lifting and positioning of machines and similar heavy equipment.

Features

- Integrated hydraulic pump.
- Pump lever swivel mounted 270° for operation even in extremely confined areas.
- Same load can be lifted on either the head or the claw of jack.
- Welded, distortion-proof steel construction.
- High quality, durable hydraulic components.
- The flat lifting claw allows low jacking height.
- The additional connect coupler (10t capacity and larger) for external pump operation, allows connection of hand, motor or synchronous lifting pumps (max. pressure 520 bar).
- Safe stability due to swivel-mounted support feet.
- Sensitive lowering valve for slow lowering of loads without jerks.
- When operating the jack with an external pump the installation of a manometer is mandatory.
- The integrated hydraulic pump is protected by a pressure-limiting valve.
- The jacks are delivered ready-to-use inclusive of carrying handles, hydraulic oil filling and pump lever.
- YAS-15 and YAS-25 with twin pump for higher lifting speed as well as wheels for easy transportation.



Technical data YAS

| Model | Art.-No. | Capacity t | Stroke mm | Height for applications min. in mm | Pressure max. bar | Weight approx. kg |
|--------|-----------|------------|-----------|------------------------------------|-------------------|-------------------|
| YAS-3 | N13101119 | 3 | 140 | 12 | 520 | 15.0 |
| YAS-5 | N13101120 | 5 | 140 | 15 | 520 | 19.0 |
| YAS-10 | N13101121 | 10 | 140 | 20 | 520 | 28.0 |
| YAS-15 | N13101122 | 15 | 140 | 25 | 520 | 50.0 |
| YAS-25 | N13101123 | 25 | 140 | 30 | 520 | 72.0 |

Dimensions YAS

| Model | YAS-3 | YAS-5 | YAS-10 | YAS-15 | YAS-25 |
|------------|-------|-------|--------|--------|--------|
| A min., mm | 12 | 15 | 20 | 25 | 30 |
| A max., mm | 230 | 232 | 300 | 291 | 300 |
| B, mm | 207 | 228 | 277 | 328 | 387 |
| H, mm | 250 | 252 | 252 | 316 | 330 |
| L, mm | 198 | 216 | 271 | 345 | 388 |

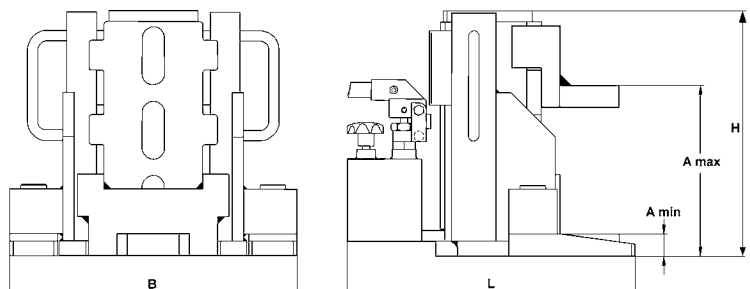



ST Hydraulic stage lifts

Capacity 50 - 100 t

For compact, low-headroom and universal applications. Stage lifts are hydraulic lifting devices which are designed to lift and lower loads over high distances.

Stage lifts overcome the usual limitations of their lifting height imposed by stroke length. Stage lifts operate with “double-acting” hydraulic cylinders (return stroke by hydraulic pressure) and are equipped with a load spreading plate and a piston support plate.

Operation

A stage lift operates inverted and lifts the load via the bottom of the cylinder whilst it climbs on a pile of support bars (wood or aluminium). In principle, the load can be lifted to any height although stage lifts are still compact and versatile for low-headroom lifting applications.

The simple “3-step operation” eliminates the need for additional holding arrangements and the repositioning or replacing of cylinders which are normally required for a higher lifting distance. A stage lift climbs up and down on its own.

Control

Depending on the power pack, selected stage lifts can be controlled individually (by hand or motor pump) or together in a synchronized arrangement with multi-flow pumps.

Features

- Yale ChroMo-Design.
- Low-cost lifting systems possible, (3-point resp. 4-point).
- Low weight (e.g. 60 kg for a 50 t unit).
- Stage lift body made from high-grade aluminium.
- Hydraulic cylinders are made from robust chromium-molybdenum steel with double bronze bearings ensure a longlife service system.
- Large-diameter tilt saddle.
- Incl. coupler halves, non-interchangeable on request



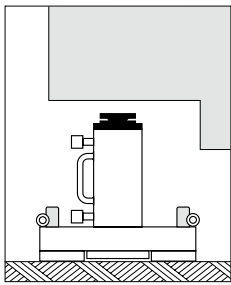

1. Stage: Initial position, stage lift rests on the ground under the load.

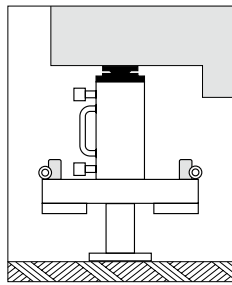

2. Stage: Step 1, load is raised.

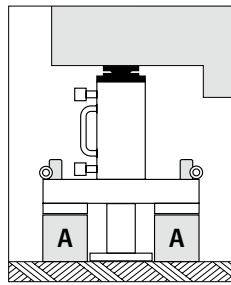

3. Stage: Two support bars type "A" are positioned in place.

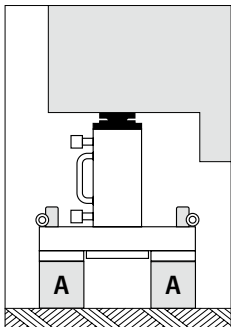

4. Stage: Piston is retracted and load rests on support bars type "A".

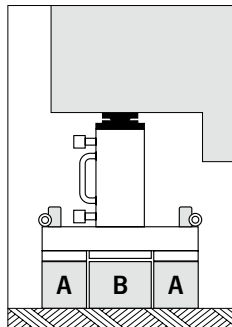

5. Stage: Broader middle bar "B" is inserted.

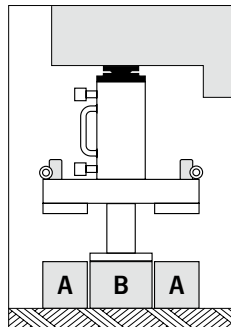

6. Stage: Step 2, load raised on broader middle bar "B".

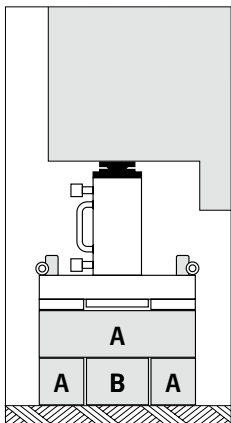

7. Stage: Two bars "A" are inserted and rotated at 90°, piston is retracted and middle bar is inserted.

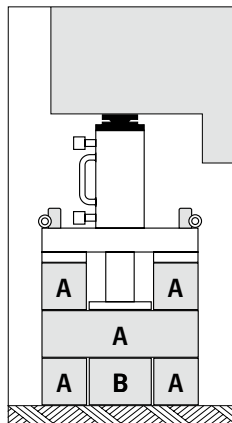

8. Stage: Load is lifted on middle bar (3rd step), two support bars type "A" are positioned at 90° and load rests on support bars "A".

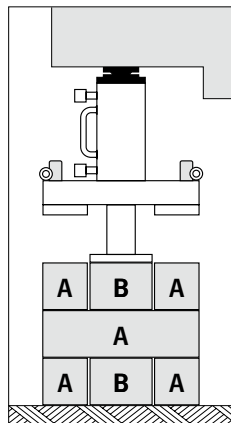

9. Stage: Piston is retracted, middle bar type "B" is inserted and lifts the 4th step on middle bar "B" and so on...

Technical data ST

| Model | Art.-No. | Capacity max. t | Stroke mm | Overall height mm | Load-spreading plate mm | Piston plate Ø mm | Weight approx. kg |
|----------|-----------|--------------------|--------------|----------------------|----------------------------|----------------------|----------------------|
| ST-5015 | N15000923 | 50 | 150 | 396 | 425 x 425 | 160 | 60 |
| ST-10015 | - | 100 | 150 | 455 | 525 x 525 | 180 | 115 |

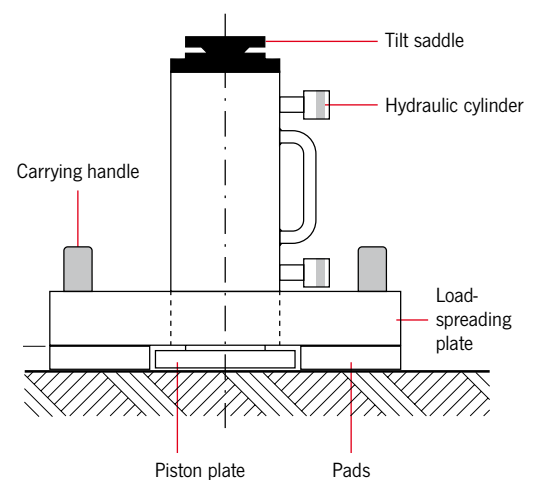



YHS Hydraulic spreader

Capacity max. 0.5 - 1.5 t

These universal power tools can be used for all repair, maintenance and assembly work requiring precisely controlled power, e.g. aligning of containers and shells, lifting, positioning or aligning of machinery and structural components, forcing-off of shutterings and moulds. Applications are unlimited.

The spreaders can be operated with all hand pumps.

Features

- Operating pressure max. 700 bar.
- Single-acting with spring return.
- Works in all positions.
- Spreader arms of high-tensile steel.
- Incl. female coupler half CFY-1 with dust cap.

Technical data YHS

| Model | Art.-No. | Capacity max. kN | Capacity max. t | Operating pressure max. bar | Oil volume max. cm ³ | Spread width min. mm | Spread width max. mm | Weight kg |
|--------|-----------|------------------|-----------------|-----------------------------|---------------------------------|----------------------|----------------------|-----------|
| YHS-05 | N13400910 | 5 | 0.5 | 700 | 10 | 16 | 75 | 1.9 |
| YHS-11 | N13900767 | 10 | 1.0 | 700 | 10 | 14 | 85 | 2.1 |
| YHS-15 | N13900609 | 15 | 1.5 | 700 | 70 | 35 | 220 | 6.9 |



YCC-201 Hydraulic chain cutter

This hydraulic chain cutter has been designed for cutting high-tensile, grade 10 chains up to a material diameter of 13 mm. The open design allows easy positioning of the chain. The unit can be operated using the standard hand or motor pumps.

Recommended pump:

Electric power pack model PY-04/2/5/2M

Features

- Cutting performance:
 - max. material dimension grade 10 Ø: 13 mm
 - max. cutting force: 23 t
 - Weight: 37.4 kg
- Solid, stable and rigid body
- Built-in standard hydraulic cylinder, single-acting with spring return
- Both through-hardened cutting blades are identical in construction, can be re-sharpened and are easy to remove

PPS Hydraulic propeller press system

Operating pressure max. 2000 bar

The hydraulic propeller press system is used to press-fit large propellers onto the drive shaft of ships.

To this end the special flat cylinders can be linked together to build a chain of any length and press force. The cylinders are provided with appropriate link eyes at both sides.

The max. operating pressure of 2000 bar ensures high pressure forces up to 1600t or more.

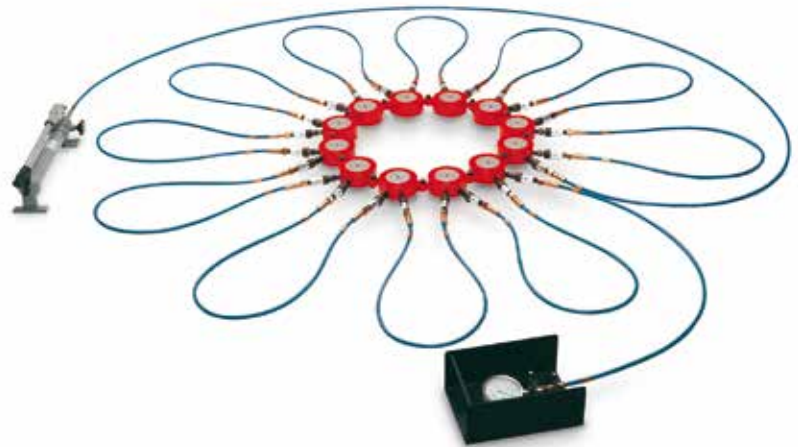

A complete hydraulic propeller press system with 12 cylinders with a total capacity of 1200 tons. The system is complete with appropriate connecting hoses with quick-release couplers, pressure gauge and hand pump TWAZ-2,3. All parts are designed for a maximum operating pressure of 2000 bar.

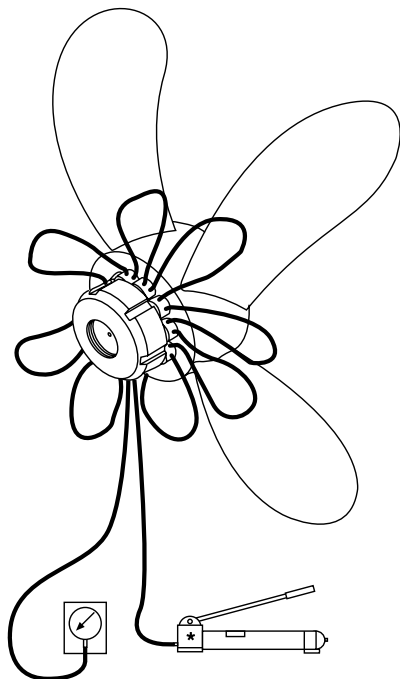

Special flat hydraulic cylinder

With link connections at both sides and 2 male quick connect coupler halves

Capacity max. 100 t.

Stroke 10 mm.

Pressure max. 2000 bar.

Diameter 127 mm.

Closed height 50 mm.

(Couplings do not belong to the scope of supply and must be ordered separately)



Link plates and lifting hooks

They are used to connect the cylinders and to handle the complete chain with a crane. 2 pieces of link plates and lifting hooks as well as the corresponding number of high-pressure hoses (with female quick connect couplers at both ends) belong to a complete set.





RPYS-1215 Hydraulic test rig for hoisting equipment

Capacity max. 12 t

For testing pul-lifts, lever hoists, chain blocks, wire rope pullers as well as other lifting equipment after repair or inspection.

Testing of hoisting equipment

The lifting unit is placed between upper and lower shackle, the chain is tensioned against the oil cushion of the partly advanced piston of the hydraulic cylinder.

The applied force can be read at the pressure gauge.

Testing of the hoist brake

For a functional test of the hoist brake the hand pump may be used to apply a counter pressure and thus increase the pulling force after a general test.

Frequent use

For frequent testing, the hand pump may be replaced by a low-cost air hydraulic (model PAY-6) or electric pump (model PY-04/2/5/2 M).

Pressure gauge

To read pulling forces more easily, the test rig is equipped with two high-quality pressure gauges.

Quick couplers allow an easy replacement of pressure gauges.

Pressure gauge 1 for small test items: GGY-1005, display: 0 - 160 bar, Ø 100 mm, Kl. 1.0 %

Pressure gauge 2 for big test items: GGY-1003, display: 0 - 400 bar, Ø 100 mm, Kl. 1.0 %



Permanent load lifting magnet TPM 0,3 for a test in the test rig RPYS-1215 complete with the test plate AYP-1215-S



AYP-1215-S Test plate for permanent load lifting magnets

Test load max. 12 t

For testing of permanent load lifting magnets according to DIN EN 13155.

The plate is placed into the 12 ton test rig RPYS-1215 (or other versions of this test rig) and connected to the frame with a bolt.

The test plate with a standardised surface according to DIN EN 13155 kann be adjusted horizontally to align it steadily.

Dimensions: 800 x 490 x 60 mm

Features

- Fully welded, low-strain press-frame.
- Upper and lower hook suspension by means of shackles, incl. two 5 tons pull-rings for smaller test units.
- Lateral pump table.
- Infinite adjustment of the pulling force.
- Chart for easy determination of test force.
- Removable lower suspension e.g. for testing of plate clamps.
- Base pre-drilled for mounting.
- High-quality hydraulic components.
- YCS-21/150 hollow cylinder made from chromium-molybdenum steel, heat-treated and hard chromium-plated. Long cylinder stroke of 150 mm with bronze bearings.
- Two-stage quick action hand pump HPS-2/0,7A.
- High-strength threaded bar M27.
- Fine-adjustment pressure valve.

Technical data RPYS

| Model | Art.-No. |
|-----------|-----------|
| RPYS-1215 | N13700895 |

Dimensions RPYS

| Model | RPYS-1215 |
|---------------------|-------------|
| A, mm | 2580 - 2730 |
| B, mm | 2160 |
| C, mm | 1840 |
| D, mm | 500 |
| E, mm | 630 |
| F, mm | 760 |
| G ¹ , mm | 1030 - 1425 |
| H, mm | 750 |
| J, mm | 150 |
| Weight, kg | 225 |

¹700 mm with 5 t pull-rings

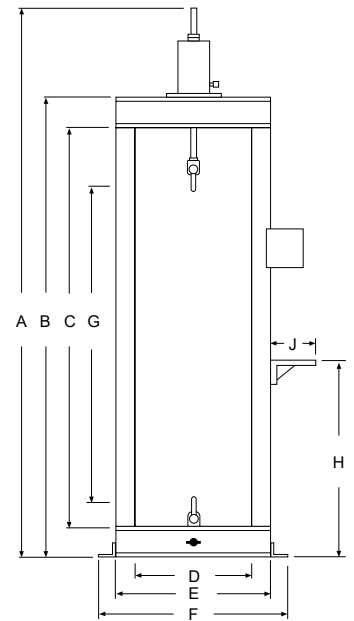

INFO

The test rigs are delivered complete and ready to use.



**RPYS-1535
Hydraulic test rig
for steel winches**

Capacity max. 15 t

For the testing of steel winches or similar lifting devices we offer a specific test rig.

Features

- Max. capacity 15 t.
- With hydraulic cylinder model YS-15/350.
- Stroke: 350 mm.

Scope of delivery

- Incl. two-stage hand pump model: HPS-2/2 A.
- Fine-adjustment pressure valve 0 - 700 bar.
- Hydraulic hose 2 m, model: HHC-20.
- Pressure gauge: GGY-1004, display: 0 - 700 bar, Ø 100 mm, Kl. 1.0%.



RPY-10 ... (10t press)
RPY-23 ... (23t press)

RPY and RPES Universal workshop presses

Capacity 10 - 200t

For all repair and assembly jobs.

According to European standards, all Yale workshop presses can be used without any additional protection devices as the piston speed is below 10 mm/s.

For special applications additional safety equipment (e.g. protection grid or two-hand-safety-control) can be offered on request.

Applications

- Pressing and removing of bolts, shafts, bearings.
- Straightening of beams, profiles, axles, shafts.
- Forming, bending, crimping.
- General load tests and tests of weld specimens.
- Stamping, cutting, punching.
- Pre-adjustment of tools.

Equipment of all presses

Features

- All workshop presses are ready to use, including hydraulic oil, oil level gauge.
- High pressure-hydraulic hoses.
- Glycerine-damped pressure gauges.
- Fixing holes in base profiles, adjusting device for press table and head, swivelling pump console, conversion chart: Pressure-force etc.

Description of the hydraulic cylinders

Features

- Cylinders made from chromium-molybdenum steel, heat-treated and with metric mounting threads in the piston.
- Double bronze bearing of the hard chromium-plated piston.
- Piston return through spring or hydraulically.
- Mounting thread in the piston.
- Available piston strokes from 150 up to 500 mm.

Description of the press-frame

Features

- Robust, torsion-resistant construction.
- Solid, precision-welded press-frames.
- Open construction, easily accessible from all sides.
- 50 and 100 tons workshop presses with adjustable press table and press head (frames for adjustments are part of the delivery package).
- 200t press with adjustable table and fix welded press head.
- Four locking bolts ensure a precisely aligned press head and press table and increase the stability of the frame (50 and 100t).
- 50, 100 and 200 t presses with pivoting pump table with peripheral passage for straightening of exceptionally long parts.
- Modular system: Large variety of combinations of hydraulic cylinders and pumps possible.
- Drive either by hand or electric hydraulic pumps.



RPY-50 ... (50t press)
RPY-100 ... (100t press)

INFO

The press head of the 200t model is fix welded to the press-frame.

Workshop presses are delivered ready to use.

Description of the hand pumps

Features

- All hand pumps with two-stage displacement.
- Glycerine-damped pressure gauge, Ø63 mm, class 1.6 %.
- Hydraulic hose, L = 2.0 m with male coupler half.

Description of the hydraulic power packs

Features

- Longlife radial piston pumps, from 50 t with two-stage displacement.
- Pressure pre-set valve on request (standard equipment for the solenoid valves).
- Glycerine-damped pressure gauge, Ø100 mm, class 1.0 %.
- Control by manual directional valve (with motor start-stop remote control) or solenoid valve with pendant remote control box.



RPES 10 ... (10t press)
RPES 30 ... (30t press)

Technical data RPY and RPES

| Model | Art.-No. | Frame design | Capacity t | Cylinder model | Cylinder stroke in mm | Piston return | Type of pump | Valve control | Pump model |
|---------------------|-----------|--------------|------------|----------------|-----------------------|---------------|--------------|---------------|--------------------|
| RPY-1015 M-2 | N13700896 | bench press | 10 | YS-10/150 | 150 | spring | manual | manual | HPS-2/0,7 A |
| RPY-1025 EM-PYE 07 | N13700021 | bench press | 10 | YS-10/250 | 250 | spring | electric | manual | PYE-07/3/10/3M-RPY |
| RPY-2316 M-2 | N13700898 | bench press | 23 | YS-23/160 | 160 | spring | manual | manual | HPS-2/0,7 A |
| RPY-2325 M-2 | N13700900 | bench press | 23 | YS-23/250 | 250 | spring | manual | manual | HPS-2/2 A |
| RPY-2325 EM-PYE 07 | N13700017 | bench press | 23 | YS-23/250 | 250 | spring | electric | manual | PYE-07/3/10/3M-RPY |
| RPES-1015 M-2 | N13700004 | floor press | 10 | YS-10/150 | 150 | spring | manual | manual | HPS-2/0,7 A |
| RPES-1025 EM-PYE 07 | N13700022 | floor press | 10 | YS-10/250 | 250 | spring | electric | manual | PYE-07/3/10/3M-RPY |
| RPES-2316 M-2 | N13700006 | floor press | 23 | YS-23/160 | 160 | spring | manual | manual | HPS-2/0,7 A |
| RPES-2325 M-2 | N13700900 | floor press | 23 | YS-23/250 | 250 | spring | manual | manual | HPS-2/2 A |
| RPES-2325 EM-PYE 07 | N13700020 | floor press | 23 | YS-23/250 | 250 | spring | electric | manual | PYE-07/3/10/3M-RPY |
| RPY-5015 EM | N13701005 | floor press | 50 | YH-50/150 | 150 | hydraulic | electric | manual | PY-04/2/5/4M |
| RPY-5035 EM | N13700912 | floor press | 50 | YH-50/350 | 350 | hydraulic | electric | manual | PY-04/2/5/4M |
| RPY-5035 EE | N13700913 | floor press | 50 | YH-50/350 | 350 | hydraulic | electric | solenoid | PYS-07/3/10/4 E |
| RPY-5050 EE | N13701006 | floor press | 50 | YH-50/500 | 500 | hydraulic | electric | solenoid | PYS-07/3/10/4 E |
| RPY-10035 EM | N13700914 | floor press | 100 | YH-100/350 | 350 | hydraulic | electric | manual | PY-07/3/10/4 M-RPY |
| RPY-10035 EE | N13700915 | floor press | 100 | YH-100/350 | 350 | hydraulic | electric | solenoid | PY-07/3/10/4 E |
| RPY-10050 EM | N13700916 | floor press | 100 | YH-100/500 | 500 | hydraulic | electric | manual | PY-07/3/10/4 M-RPY |
| RPY-10050 EE | N13701008 | floor press | 100 | YH-100/500 | 500 | hydraulic | electric | solenoid | PY-07/3/10/4 E |
| RPY-20035 EM | N13700917 | floor press | 200 | YH-200/350 | 350 | hydraulic | electric | manual | PY-11/3/20/4 M-RPY |
| RPY-20035 EE | N13700918 | floor press | 200 | YH-200/350 | 350 | hydraulic | electric | solenoid | PY-11/3/20/4 E |
| RPY-20050 EM | N13700919 | floor press | 200 | YH-200/500 | 500 | hydraulic | electric | manual | PY-11/3/20/4 M-RPY |
| RPY-20050 EE | N13701017 | floor press | 200 | YH-200/500 | 500 | hydraulic | electric | solenoid | PY-11/3/20/4 E |

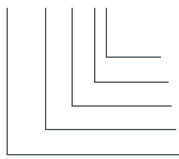

Code explanation

- Valve control : M = manual pump, E = solenoid valve with pendant remote control
- Pump : M = manual pump, E = electric pump
- Piston stroke : 15 = 150mm, 16 = 160mm, 25 = 250mm, 35 = 350mm, 50 = 500mm
- Capacity max. : 10 = 10t, 23 = 23t, 50 = 50t, 100 = 100t, 200 = 200t
- Model

Dimensions RPY and RPES (only frame)

| Model | RPY-10 | RPY-23 | RPES-10 | RPES-23 | RPY-50 | RPY-100 | RPY-200 |
|--------------------|--------|--------|---------|---------|--------|---------|---------|
| A min., mm | - | - | 50 | 50 | 280 | 270 | 320 |
| A max., mm | 440 | 440 | 930 | 930 | 1120 | 830 | 1000 |
| B, mm | 380 | 380 | 700 | 700 | 820 | 1000 | 1000 |
| C, mm | 510 | 510 | 650 | 650 | 1020 | 1300 | 1400 |
| D, mm | - | - | 500 | 500 | 1200 | 1480 | 1580 |
| E, mm | 180 | 180 | - | - | 920 | 860 | 1040 |
| F, mm | - | - | 150 | 150 | 140 | 140 | 170 |
| G, mm | - | - | 240 | 240 | 255 | 335 | 450 |
| H, mm | 840 | 840 | 1695 | 1695 | 2000 | 2000 | 2430 |
| I, mm | 300 | 300 | 245 | 245 | 315 | 395 | 550 |
| K, mm | - | - | - | - | 1000 | 1000 | 1000 |
| L, mm | - | - | - | - | 383 | 333 | 400 |
| Weight approx., kg | 77 | 77 | 94 | 94 | 450 | 950 | 2380 |

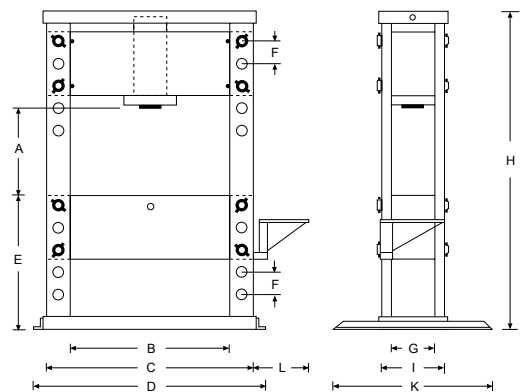

RPY-50, 100 and 200

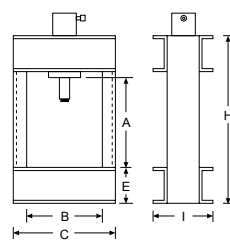

RPY-10 up to 23

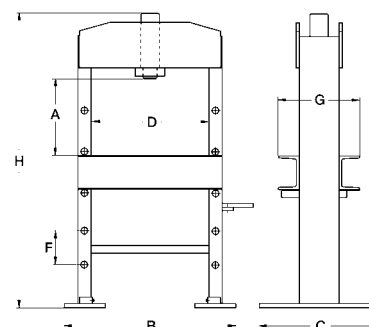

RPES-10 up to 30

Selection chart for single-acting systems

Which hand pump is suitable for which hydraulic cylinder?

The appropriate hand pump model basically depends on the oil volume of the selected hydraulic cylinders.

To assist you in your choice please find proposals for the most common cylinders in our range.

How to find the right hand pump in the following charts?

The chosen hydraulic cylinder can be found in the first column.

Several hydraulic cylinders connected to one hand pump:

In those cases where several hydraulic cylinders are connected to one hand pump, the oil volume must be multiplied by the number of connected cylinders. The reservoir of the hand pump must be at least equal to the required total oil volume (plus reserve). If the reserve is very small it may be necessary to top up the reservoir after the air-bleeding procedure, depending on the length of the hydraulic hose. During further operation there is no need to consider the volume of the connected hydraulic hose (regardless of the length) because hoses always remain filled.

Double-acting systems:

Please note that while advancing a double-acting cylinder, about 1/3 of the cylinder's oil volume flows back to the reservoir (coming from the piston chamber). After the air-bleeding procedure both oil chambers will remain filled.



INFO

Please contact us for any questions regarding the configuration of complex systems according to your specific requirement.

Selection chart for single-acting systems

| Model | Oil volume cm ³ | Hand pumps single-stage HPS-1/0,7A 700 cm ³ | Hand pumps two-stage HPS-2/0,3A 300 cm ³ | Hand pumps two-stage HPS-2/0,7A 700 cm ³ | Hand pumps two-stage HPS-2/1,3A 1300 cm ³ | Hand pumps two-stage HPS-2/2A 2000 cm ³ | Hand pumps two-stage HPS-2/4A 4000 cm ³ | Hand pumps two-stage HPS-2/6,5A 6500 cm ³ |
|------------|-------------------------------|---|--|--|---|---|---|---|
| YS-5/15 | 11 | +++ | +++ | - | - | - | - | - |
| YS-5/25 | 18 | +++ | +++ | +++ | - | - | - | - |
| YS-5/75 | 53 | +++ | +++ | +++ | - | - | - | - |
| YS-5/127 | 90 | +++ | +++ | +++ | - | - | - | - |
| YS-5/180 | 127 | +++ | +++ | +++ | - | - | - | - |
| YS-10/25 | 37 | +++ | ++ | +++ | - | - | - | - |
| YS-10/50 | 73 | +++ | ++ | +++ | - | - | - | - |
| YS-10/100 | 146 | +++ | ++ | +++ | - | - | - | - |
| YS-10/150 | 218 | +++ | - | +++ | - | - | - | - |
| YS-10/200 | 291 | +++ | - | +++ | - | - | - | - |
| YS-10/250 | 363 | +++ | - | +++ | ++ | - | - | - |
| YS-10/300 | 463 | ++ | - | +++ | ++ | - | - | - |
| YS-15/25 | 53 | +++ | ++ | +++ | - | - | - | - |
| YS-15/50 | 106 | +++ | ++ | +++ | - | - | - | - |
| YS-15/100 | 213 | +++ | - | +++ | ++ | - | - | - |
| YS-15/150 | 319 | +++ | - | +++ | ++ | - | - | - |
| YS-15/200 | 425 | ++ | - | +++ | ++ | ++ | - | - |
| YS-15/250 | 531 | ++ | - | +++ | +++ | ++ | - | - |
| YS-15/300 | 637 | - | - | - | +++ | +++ | - | - |
| YS-15/350 | 744 | - | - | - | +++ | +++ | - | - |
| YS-23/25 | 83 | +++ | - | +++ | - | - | - | - |
| YS-23/50 | 166 | +++ | - | +++ | - | - | - | - |
| YS-23/100 | 332 | +++ | - | +++ | ++ | ++ | - | - |
| YS-23/160 | 531 | ++ | - | +++ | +++ | ++ | - | - |
| YS-23/210 | 697 | - | - | - | +++ | ++ | - | - |
| YS-23/250 | 830 | - | - | - | +++ | ++ | - | - |
| YS-23/300 | 996 | - | - | - | +++ | ++ | - | - |
| YS-23/345 | 1145 | - | - | - | +++ | +++ | - | - |
| YS-30/125 | 552 | ++ | - | +++ | +++ | +++ | - | - |
| YS-30/200 | 884 | - | - | - | +++ | +++ | - | - |
| YS-50/50 | 355 | ++ | - | +++ | +++ | +++ | - | - |
| YS-50/100 | 709 | - | - | - | +++ | +++ | - | - |
| YS-50/160 | 1135 | - | - | - | +++ | +++ | - | - |
| YS-50/320 | 2269 | - | - | - | - | - | +++ | ++ |
| YS-70/150 | 1478 | - | - | - | - | +++ | +++ | ++ |
| YS-70/330 | 3252 | - | - | - | - | - | ++ | +++ |
| YS-100/100 | 1432 | - | - | - | - | +++ | ++ | ++ |
| YS-100/200 | 2863 | - | - | - | - | - | +++ | ++ |
| YLS-10/35 | 51 | +++ | +++ | +++ | - | - | - | - |
| YLS-20/45 | 128 | +++ | ++ | +++ | - | - | - | - |
| YLS-30/60 | 266 | ++ | ++ | +++ | - | - | - | - |
| YLS-50/60 | 426 | ++ | - | +++ | ++ | ++ | - | - |
| YLS-100/55 | 788 | - | - | - | +++ | +++ | - | - |
| YFS-10/11 | 16 | +++ | +++ | +++ | - | - | - | - |
| YFS-20/15 | 31 | +++ | +++ | +++ | - | - | - | - |
| YFS-50/15 | 107 | +++ | ++ | +++ | - | - | - | - |
| YFS-100/15 | 215 | +++ | - | +++ | - | - | - | - |
| YCS-12/40 | 71 | +++ | +++ | +++ | - | - | - | - |
| YCS-12/75 | 132 | +++ | +++ | +++ | - | - | - | - |
| YCS-21/50 | 153 | +++ | ++ | +++ | - | ++ | - | - |
| YCS-21/150 | 458 | +++ | - | +++ | ++ | ++ | - | - |
| YCS-33/60 | 287 | +++ | - | +++ | - | - | - | - |
| YCS-33/150 | 716 | - | - | - | +++ | +++ | - | - |
| YCS-57/70 | 562 | ++ | - | +++ | +++ | +++ | - | - |
| YCS-62/150 | 1330 | - | - | - | - | +++ | +++ | - |
| YCS-93/75 | 990 | - | - | - | +++ | +++ | - | - |

+++ recommended hand pump

++ these combinations can also be used, but the oil volume of the hand pump is quite small

- these combinations should not be chosen, because the oil volumes of the hand pumps are too small to fill the selected cylinder (too large and bulky, respectively)



Selection chart for double-acting systems

| Model | Oil volume cm ³ | Hand pumps two-stage HPH-2/0,7A 700 cm ³ | Hand pumps two-stage HPH-2/2A 2000 cm ³ | Hand pumps two-stage HPH-2/4A 4000 cm ³ | Hand pumps two-stage HPH-2/6,5A 6500 cm ³ | Hand pumps two-stage HPH-2/10A 10000 cm ³ |
|-------------|-------------------------------|--|---|---|---|---|
| YCH-33/150 | 716 | ++ | +++ | - | - | - |
| YCH-33/250 | 1200 | - | +++ | ++ | - | - |
| YCH-62/250 | 2220 | - | +++ | +++ | - | - |
| YCH-93/250 | 3320 | - | - | +++ | ++ | - |
| YCH-100/40 | 578 | +++ | +++ | - | - | - |
| YCH-140/200 | 4080 | - | - | +++ | ++ | - |
| YH-5/30 | 21 | +++ | - | - | - | - |
| YH-5/80 | 57 | +++ | - | - | - | - |
| YH-5/150 | 106 | +++ | - | - | - | - |
| YH-10/30 | 44 | +++ | - | - | - | - |
| YH-10/80 | 116 | +++ | - | - | - | - |
| YH-10/150 | 218 | +++ | - | - | - | - |
| YH-10/250 | 363 | +++ | ++ | - | - | - |
| YH-20/50 | 142 | +++ | ++ | - | - | - |
| YH-20/150 | 424 | +++ | +++ | - | - | - |
| YH-20/250 | 707 | ++ | +++ | - | - | - |
| YH-30/200 | 884 | - | +++ | - | - | - |
| YH-30/350 | 1547 | - | +++ | - | - | - |
| YH-50/150 | 1064 | - | +++ | - | - | - |
| YH-50/350 | 2481 | - | ++ | +++ | - | - |
| YH-50/500 | 3544 | - | - | +++ | ++ | - |
| YH-70/150 | 1478 | - | +++ | - | - | - |
| YH-70/350 | 3449 | - | - | +++ | ++ | - |
| YH-100/50 | 716 | +++ | +++ | - | - | - |
| YH-100/150 | 2148 | - | +++ | +++ | - | - |
| YH-100/350 | 5010 | - | - | ++ | +++ | - |
| YH-100/500 | 7157 | - | - | - | ++ | +++ |
| YH-200/150 | 4253 | - | - | +++ | +++ | - |
| YH-200/350 | 9924 | - | - | - | ++ | +++ |
| YH-200/500 | 14177 | - | - | - | - | +++ |

+++ recommended hand pump

++ these combinations can also be used, but the oil volume of the hand pump is quite small

- these combinations should not be chosen, because the oil volumes of the hand pumps are too small to fill the selected cylinder (too large and bulky, respectively)

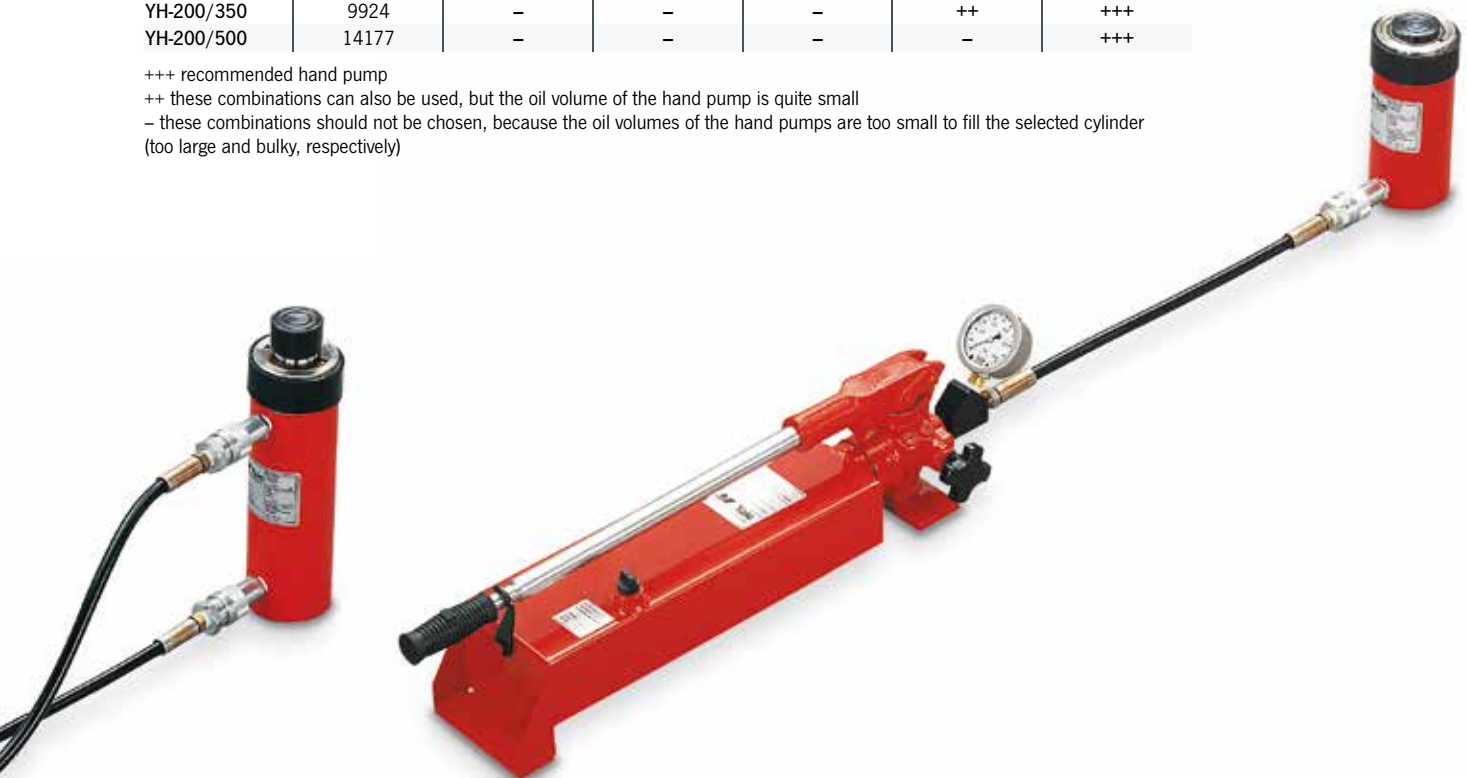

Pump and cylinder speed chart

Hand pumps

For hand pumps the figures given correspond to the number of pump strokes to achieve a piston travel of 10 mm.

Power pumps

For power pumps the piston travel speed is indicated in mm/s.

Double-acting hydraulic cylinders

Please note that double-acting cylinders (YCH, YH and YEHB) always retract faster than they advance, due to the different oil chamber volumes.

Reservoir volumes

The reservoir volumes of hand pumps shall at least correspond to the oil volume which is necessary to advance all connected hydraulic cylinders (plus reserve). Motor pump reservoirs should have at least twice the total required oil quantity (better 3 or 4 times) depending on the operation conditions. For continuous operation choose extra large reservoirs to avoid excessive heating-up of the hydraulic oil.

Hand pumps

| Cylinder size t | Number of pump strokes for 10 mm strokes | |
|--------------------|--|--------------------------------------|
| | HPS-2/0,7A up to HPS-2/10 A ND | HPS-1/0,7A up to HPS-2/10 A HD |
| 5 | 1 | 4 |
| 10 | 1 | 7 |
| 15 | 2 | 11 |
| 20 | 2 | 14 |
| 21 | 2 | 15 |
| 23 | 3 | 17 |
| 30 | 3 | 22 |
| 33 | 4 | 24 |
| 50 | 5 | 35 |
| 57 | 6 | 40 |
| 62 | 7 | 44 |
| 70 | 8 | 49 |
| 85 | 9 | 61 |
| 93 | 10 | 66 |
| 100 | 11 | 72 |
| 140 | 15 | 100 |
| 200 | 22 | 142 |
| 220 | 24 | 157 |
| 340 | 32 | 205 |
| 430 | 47 | 308 |
| 560 | 62 | 402 |
| 670 | 74 | 481 |
| 880 | 97 | 628 |

ND = Low-pressure stage (unloaded stroke)
HD = High-pressure stage (loaded stroke)



Power pumps

| Cylinder size t | Piston travel speed in mm/s | | | | | | | | | | | | | |
|--------------------|-----------------------------|-------------|-------------|-------------|-------------|-------------|-------------|-------------|--------------|--------------|--------------|---------------|---------------|--|
| | PY-04 ND | PY-04 HD | PY-07 ND | PY-07 HD | PY-11 ND | PY-11 HD | PY-22 ND | PY-22 HD | PYE-40 HD | PYE-55 HD | PYE-75 HD | PYE-110 HD | PYE-180 HD | |
| 5 | 99.9 | 5.4 | 155.9 | 14.2 | - | - | - | - | 63.8 | - | - | - | - | |
| 10 | 48.7 | 2.6 | 75.9 | 6.9 | 103.5 | 11.5 | - | - | 31.1 | 46 | 69 | - | - | |
| 15 | 33.3 | 1.8 | 51.9 | 4.7 | 70.8 | 7.9 | - | - | 21.2 | 31.5 | 47.2 | 62.9 | - | |
| 20 | 25.0 | 1.4 | 39.0 | 3.5 | 53.2 | 5.9 | 106.9 | 12.4 | 15.9 | 23.6 | 35.4 | 47.3 | 75.0 | |
| 21 | 23.2 | 1.3 | 36.1 | 3.3 | 49.3 | 5.5 | 99.1 | 11.5 | 14.8 | 21.9 | 32.8 | 43.8 | 69.5 | |
| 23 | 21.3 | 1.2 | 33.2 | 3.0 | 45.3 | 5.0 | 91.1 | 10.6 | 13.6 | 20.1 | 30.2 | 40.3 | 63.9 | |
| 30 | 16.0 | 0.9 | 24.9 | 2.3 | 34.0 | 3.8 | 68.4 | 7.9 | 10.2 | 15.1 | 22.7 | 30.2 | 48.0 | |
| 33 | 14.8 | 0.8 | 23.1 | 2.1 | 31.5 | 3.5 | 63.4 | 7.4 | 9.5 | 14 | 21 | 28.0 | 44.5 | |
| 50 | 10.0 | 0.5 | 15.6 | 1.4 | 21.2 | 2.4 | 42.6 | 4.9 | 6.4 | 9.4 | 14.1 | 18.8 | 29.9 | |
| 57 | 8.8 | 0.5 | 13.7 | 1.2 | 18.7 | 2.1 | 37.7 | 4.4 | 5.6 | 8.3 | 12.5 | 16.7 | 26.4 | |
| 62 | 8.0 | 0.4 | 12.4 | 1.1 | 17.0 | 1.9 | 34.1 | 4.0 | 5.1 | 7.5 | 11.3 | 15.1 | 24.0 | |
| 70 | 7.2 | 0.4 | 11.2 | 1.0 | 15.3 | 1.7 | 30.7 | 3.6 | 4.6 | 6.8 | 10.2 | 13.6 | 21.5 | |
| 85 | 5.8 | 0.3 | 9.0 | 0.8 | 12.3 | 1.4 | 24.7 | 2.9 | 3.7 | 5.4 | 8.2 | 10.9 | 17.3 | |
| 93 | 5.4 | 0.3 | 8.4 | 0.8 | 11.4 | 1.3 | 22.9 | 2.7 | 3.4 | 5.1 | 7.6 | 10.1 | 16.1 | |
| 100 | 4.9 | 0.3 | 7.7 | 0.7 | 10.5 | 1.2 | 21.1 | 2.5 | 3.2 | 4.7 | 7.0 | 9.3 | 14.8 | |
| 140 | 3.5 | 0.2 | 5.5 | 0.5 | 7.5 | 0.8 | 15.0 | 1.7 | 2.2 | 3.3 | 5.0 | 6.7 | 10.6 | |
| 200 | 2.5 | 0.1 | 3.9 | 0.4 | 5.3 | 0.6 | 10.7 | 1.2 | 1.6 | 2.4 | 3.5 | 4.7 | 7.5 | |
| 220 | 2.2 | 0.1 | 3.5 | 0.3 | 4.8 | 0.5 | 9.6 | 1.1 | 1.4 | 2.1 | 3.2 | 4.3 | 6.8 | |
| 340 | - | - | 2.7 | 0.2 | 3.7 | 0.4 | 7.4 | 0.9 | 1.1 | 1.6 | 2.4 | 3.3 | 5.2 | |
| 430 | - | - | 1.8 | 0.2 | 2.4 | 0.3 | 4.9 | 0.6 | 0.7 | 1.1 | 1.6 | 2.2 | 3.4 | |
| 560 | - | - | 1.4 | 0.1 | 1.9 | 0.2 | 3.8 | 0.4 | 0.6 | 0.8 | 1.2 | 1.7 | 2.6 | |
| 670 | - | - | 1.1 | 0.1 | 1.6 | 0.2 | 3.1 | 0.4 | 0.5 | 0.7 | 1.0 | 1.4 | 2.2 | |
| 880 | - | - | 0.9 | 0.1 | 1.2 | 0.1 | 2.4 | 0.3 | 0.4 | 0.5 | 0.8 | 1.1 | 1.7 | |

ND = Low-pressure stage (unloaded stroke)
 HD = High-pressure stage (loaded stroke)
 - = combination not recommended or not possible



Workshop Equipment

The product division “Workshop equipment” comprises a modern, high performance system, which, due to its versatility and flexibility, ensures that a multitude of applications in workshops are significantly simplified.

Hydraulic car jacks up to 50t and hydraulic trolley jacks up to 15t and many other products make daily working life easier and more ergonomic.

Workshop presses with a capacity of up to 100t are an indispensable tool when removing or inserting bearings or bushes etc.

The following applies also to our workshop equipment: dependability is ensured through a combination of high quality, functionality and safety.

Table of contents

| | Page |
|-------------------------------------|------------------|
| Jacks | 422 - 425 |
| Workshop presses | 426 - 428 |
| Workshop presses/Accessories | 429 |
| Service jacks | 430 - 431 |
| Supporting stand | 432 |
| Hydraulic repair set | 433 |

PFAFF

silberblau

WORKSHOP EQUIPMENT



PFAFF
silberblau



HWH 2K, 3t



HWH KS, 5t

HWH 2K PROLINE

Hydraulic car jack

-with 2 pistons

HWH 2KS PROLINE

-with 2 pistons and spindle

HWH KS PROLINE

-with piston and spindle

Capacity 2 - 30t

For lifting vehicles on one side (the lifted load must be secured mechanically with supporting stands, for example).

Features

- Versions with hydraulic piston and mechanical spindle drive resp. with two hydraulic pistons.
- With carrying bracket from load capacity 20t.
- Extremely low design with model HWH 2K/D (incl. one pressure section for lift extension).
- With integrated pressure control valve for a longer service life of the jack.
- Integrated seat valve for controlled lowering of the load.



HWH 2K NB, 10t



HWH 2KS, 10t



HWH KS, 20t

Technical data HWH 2K PROLINE and HWH 2KS PROLINE

| Model | Art.-No. | Capacity t | Weight kg |
|-----------------------------|----------|------------|-----------|
| HWH 2K 3,0 | 32301016 | 3 | 4.87 |
| HWH 2K 5,0 | 32304001 | 5 | 6.3 |
| HWH 2KS 10,0 | 32304002 | 10 | 8.8 |
| HWH 2KS 12,0 | 32307014 | 12 | 11.0 |
| HWH 2K NB 10,0 ¹ | 32306034 | 10 | 7.9 |
| HWH 2K/D 10,0 ² | 32304003 | 10 | 6.5 |

¹horizontal pump unit ²with replaceable pressure section (height 45 mm)

Dimensions HWH 2K PROLINE and HWH 2KS PROLINE

| Model | HWH 2K 3,0 | HWH 2K 5,0 | HWH 2KS 10,0 | HWH 2KS 12,0 | HWH 2K NB 10,0 ¹ | HWH 2K/D 10,0 ² |
|------------|------------|------------|--------------|--------------|-----------------------------|----------------------------|
| a, mm | 107 | 98 | 129 | 185 | ∅ | 140 |
| b, mm | 90 | 120 | 164 | 185 | 127 | 164 |
| c, mm | 124 | 134 | 160 | 176 | 197 | 160 |
| H min., mm | 185 | 215 | 200 | 230 | 175 | 120 |
| H max., mm | 400 | 520 | 530 | 570 | 385 | 230 |
| h1, mm | 110 | 145 | 130 | 130 | 104 | 54 |
| h2, mm | 105 | 160 | 132 | 125 | 106 | 56 |
| hTr, mm | - | - | 68 | 85 | - | - |
| ∅ k, mm | 60 x 35 | 43 | 40 | 48 | 43 | 38 |
| l, mm | 115 | 134 | 116 | 53 | 136 | 112 |
| m, mm | 80 | 90 | 116 | 133 | 116 | 116 |
| Tr, mm | - | - | 32 x 5 | 40 x 6 | - | - |
| ∅ z1, mm | 32 | 39 | 52.58 | 61.5 | 52.5 | 52.5 |
| ∅ z2, mm | 23 | 29 | 39.5 | 48.5 | 39.5 | 39.5 |

¹horizontal pump unit ²with replaceable pressure section (height 45 mm)

Technical data HWH KS PROLINE with piston and spindle

| Model | Art.-No. | Capacity t | Weight kg |
|-------------|----------|------------|-----------|
| HWH KS 2,0 | 32300002 | 2 | 2.9 |
| HWH KS 3,5 | 32302004 | 3.5 | 2.9 |
| HWH KS 5,0 | 32303000 | 5 | 3.9 |
| HWH KS 8,0 | 32305003 | 8 | 5.7 |
| HWH KS 10,0 | 32306026 | 10 | 5.7 |
| HWH KS 12,0 | 32307006 | 12 | 7.1 |
| HWH KS 15,0 | 32308002 | 15 | 8.3 |
| HWH KS 20,0 | 32309009 | 20 | 10.7 |
| HWH KS 25,0 | 32310007 | 25 | 13.1 |
| HWH KS 30,0 | 32311003 | 30 | 14.5 |

Dimensions HWH KS PROLINE with piston and spindle

| Model | HWH KS 2,0 | HWH KS 3,5 | HWH KS 5,0 | HWH KS 8,0 | HWH KS 10,0 | HWH KS 12,0 | HWH KS 15,0 | HWH KS 20,0 | HWH KS 25,0 | HWH KS 30,0 |
|------------|------------|------------|------------|------------|-------------|-------------|-------------|-------------|-------------|-------------|
| a, mm | 34 | 34 | 38 | 105 | 105 | 116 | 121 | 110 | 122 | 122 |
| b, mm | 105 | 105 | 110 | 122 | 122 | 120 | 130 | 164 | 185 | 185 |
| c, mm | 103 | 103 | 110 | 124 | 124 | 134 | 139.5 | 160 | 176 | 176 |
| H min., mm | 170 | 170 | 212 | 220 | 220 | 230 | 230 | 240 | 240 | 240 |
| H max., mm | 377 | 377 | 462 | 480 | 480 | 497 | 495 | 505 | 515 | 482 |
| h1, mm | 115 | 115 | 150 | 150 | 150 | 157 | 155 | 155 | 157 | 142 |
| hTr, mm | 92 | 92 | 100 | 110 | 110 | 110 | 110 | 110 | 118 | 100 |
| ∅ k, mm | 28 | 28 | 40 | 48 | 48 | 48 | 60 | 60 | 65 | 65 |
| l, mm | 116 | 113 | 113 | 116 | 116 | 116 | 116 | 116 | 120 | 116 |
| m, mm | 58 | 58 | 65 | 80 | 80 | 90 | 95 | 116 | 133 | 133 |
| Tr, mm | 20 x 4 | 20 x 4 | 24 x 5 | 32 x 5 | 32 x 5 | 35 x 6 | 40 x 6 | 45 x 6 | 48 x 6.35 | 48 x 6.35 |
| ∅ z1, mm | 24.9 | 24.9 | 29.9 | 39.5 | 39.5 | 43.5 | 48.5 | 54.5 | 59.5 | 61.5 |

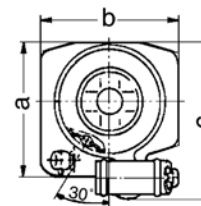
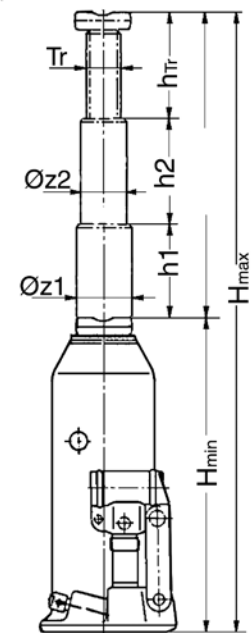
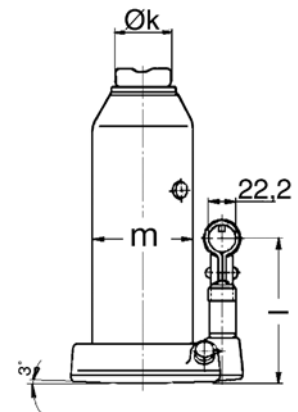

INFO

HWH KS PROLINE with capacity of 50t and 100t available on request.



JH Universal jacks

Capacity 2 - 50 t

Universal jacks supply high forces for general operations like lifting, pushing, moving, supporting of all kind of loads.

Features

- Robust, long life design.
- Pressure relief valve
- Precise controlled lowering.
- Additional screw extension of the piston (up to 20 t).
- Grooved saddle.
- Large base plates for increased stability.
- JH-50-2 with two-stage pump.
- Incl. operating lever.



JH-50-2

Technical data JH

| Model | Art.-No. | Capacity t | Stroke mm | Additional screw extension mm | Closed height mm | Base plate mm | Pump | Weight kg |
|---------|-----------|---------------|--------------|-------------------------------------|------------------------|------------------|--------------|--------------|
| JH-2 B | N13300003 | 2 | 115 | 50 | 181 | 90 x 95 | single-stage | 2.7 |
| JH-4 B | N13300004 | 4 | 126 | 60 | 205 | 115 x 110 | single-stage | 3.7 |
| JH-6 B | N13300005 | 6 | 130 | 75 | 219 | 115 x 110 | single-stage | 4.7 |
| JH-8 B | N13300006 | 8 | 152 | 70 | 225 | 120 x 120 | single-stage | 5.7 |
| JH-12 B | N13300007 | 12 | 153 | 80 | 240 | 140 x 130 | single-stage | 8.0 |
| JH-20 B | N13300008 | 20 | 153 | 80 | 240 | 160 x 155 | single-stage | 11.0 |
| JH-30 | N13300408 | 30 | 180 | - | 280 | 210 x 180 | single-stage | 22.0 |
| JH-50-2 | N13300893 | 50 | 178 | - | 305 | 255 x 190 | two-stage | 53.0 |

MH Machine jack

Capacity 5 - 25 t

For lifting heavy machinery and other loads.

Features

- Can be used in every position.
- Lifting by means of a hand pump.
- Lowering by means of a precision lowering valve.
- With carrying handle for MH 50 and MH 100.
- With carriage for MH 250.
- Pressure control valve for a longer service life of the jack.
- Integrated lifting limitation.
- Low application height of the claw.
- Slewing claw (MH 50 and MH 100)
- Large base plate for a high level of stability.
- Stable construction with hard-chromium plated piston rod.



Technical data MH

| Model | Art.-No. | Capacity t | Stroke mm | Application height min. with claw mm | Application height min. with head mm | Pump lever force with full load daN | Weight kg |
|--------|----------|---------------|--------------|--|--|---|--------------|
| MH 50 | 40014771 | 5 | 205 | 25 | ≤ 368 | 38 | 25 |
| MH 100 | 40014772 | 10 | 230 | 30 | ≤ 420 | 40 | 35 |
| MH 250 | 40014773 | 25 | 215 | 58 | ≤ 505 | 40 | 109 |

Dimensions MH

| Model | MH 50 | MH 100 | MH 250 |
|---------|-------|--------|-----------|
| A, mm | 393 | 449 | - |
| B, mm | 320 | 325 | 459 |
| C, mm | 213 | 205 | 420 |
| D, mm | 115 | 120 | 220 |
| E, mm | 53 | 55 | 90 |
| G, mm | 25 | 30 | 58 |
| H, mm | 368 | 420 | 505 |
| H1, mm | 573 | 650 | 720 |
| H2, mm | 205 | 230 | 215 |
| J, mm | 77 | 74.5 | 142.5 |
| K, mm | 93 | 108 | 175 |
| L, mm | 520 | 520 | 920/840 |
| M, mm | 740 | 745 | 1305/1225 |
| N, mm | 140 | 170 | 210/283 |
| Ø Z, mm | 76 | 91 | 155 |

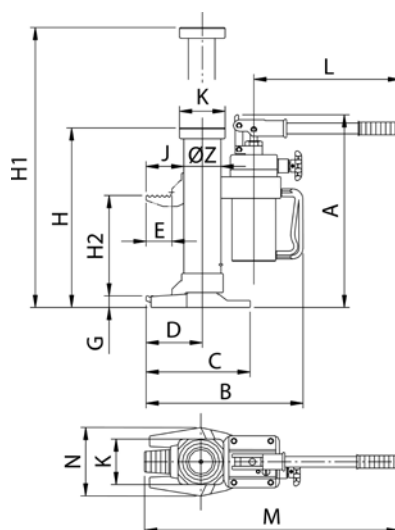



HWPHP Workshop press with hydraulic hand pump

Capacity 15 - 50t

Suitable for pressing bearings and bushes in and out, pressing and bending components, for straightening shafts and alignment work.

Features

- Versions for 15t and 20t with supporting plate, prism set and centering device (accessories optional for higher tonnages).
- Fitted with two-stage hand pump.
- With manometer as standard.
- With hand cable winch for table adjustment (from model HWPHP 30).

INFO

Intended use:

A workshop press/straightening press is a press with a slow closing speed of 25 mm/s and a maximum pressing capacity of 10 full load/full lift presses per hour.

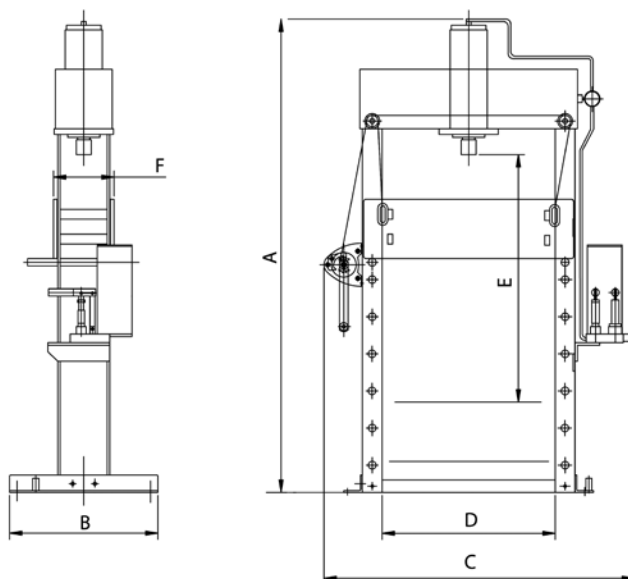

Technical data HWPHP

| Model | HWPHP 15 | HWPHP 20 | HWPHP 30 | HWPHP 40 | HWPHP 50 |
|----------------------------|----------|----------|----------|----------|----------|
| Art.-No. | 40012730 | 40012731 | 40012732 | 40012733 | 40012734 |
| Capacity, t | 15 | 20 | 30 | 40 | 50 |
| Operating pressure, bar | 240 | 320 | 250 | 330 | 330 |
| Lifting height, mm | 190 | 190 | 190 | 190 | 190 |
| Total height A, mm | 1870 | 1870 | 1920 | 2010 | 2030 |
| Total depth B, mm | 500 | 500 | 600 | 780 | 850 |
| Total width C, mm | 940 | 940 | 1260 | 1335 | 1350 |
| Clear working width D, mm | 550 | 550 | 700 | 775 | 775 |
| Clear working height E, mm | 940 | 940 | 1000 | 1125 | 1155 |
| Table width F, mm | 185 | 185 | 245 | 258 | 304 |
| Weight, kg | 160 | 160 | 250 | 310 | 420 |

HWPEP Workshop press with hydraulic electric pump

Capacity 30 - 100t

Compressed productivity in press form for repair and assembly work. This is what the workshop press offers with its reliable single- or two-stage electric pump and pressing power of up to 100 tons. Whether you are pressing bearings and bushes in and out, straightening axles, beams and shafts, or bending, pressing or setting up tools ...

The high performance of this press is based on optimized technology. For example, the press comes with a high pressure unit with a manometer, a control valve and three-way valve, an adjustable pick-up table and high-quality pistons made of chrome-plated hardened and tempered special steel.

Features

- Fitted with single- or two-stage electric pump.
- With manometer as standard.
- With hand cable winch for table adjustment.



With hand cable winch for table adjustment

At all models HWPHP and HWPEP as of 30t as standard

INFO

Accessories available as options, please see page 429.

Units with pressing power of 150/200/300t on request.

Technical data HWPEP with one-stage electric pump

| Model | HWPEP-1 30 | HWPEP-1 40 | HWPEP-1 50 | HWPEP-1 100 |
|----------------------------|----------------------|------------|------------|-------------|
| Art.-No. | 40012735 | 40012736 | 40012737 | 40012738 |
| Capacity, t | 30 | 40 | 50 | 100 |
| Operating pressure, bar | 250 | 330 | 330 | 320 |
| Lifting height, mm | 260 | 260 | 260 | 300 |
| Total height A, mm | 1880 | 2010 | 2030 | 2170 |
| Total depth B, mm | 660 | 780 | 850 | 1000 |
| Total width C, mm | 1240 | 1315 | 1410 | 1700 |
| Clear working width D, mm | 700 | 775 | 775 | 1000 |
| Clear working height E, mm | 1000 | 1125 | 1155 | 1075 |
| Table width F, mm | 245 | 258 | 300 | 415 |
| Closing speed, mm/s | 5.1 | 5.1 | 4.1 | 2.9 |
| Motor | 400V/1.5 kW | | | 400V/3 kW |
| ED, % | S 3-30% ¹ | | | |
| Weight, kg | 280 | 340 | 450 | 920 |

Technical data HWPEP with two-stage electric pump

| Model | HWPEP-2 30 | HWPEP-2 40 | HWPEP-2 50 | HWPEP-2 100 |
|---|----------------------|------------|------------|-------------|
| Art.-No. | 40012739 | 40012740 | 40012741 | 40012742 |
| Capacity, t | 30 | 40 | 50 | 100 |
| Operating pressure, bar | 250 | 330 | 330 | 320 |
| Lifting height, mm | 260 | 260 | 260 | 300 |
| Total height A, mm | 1880 | 2010 | 2030 | 2170 |
| Total depth B, mm | 660 | 780 | 850 | 1000 |
| Total width C, mm | 1240 | 1315 | 1460 | 1700 |
| Clear working width D, mm | 700 | 775 | 775 | 1000 |
| Clear working height E, mm | 1000 | 1125 | 1155 | 1075 |
| Table width F, mm | 245 | 258 | 300 | 415 |
| Closing speed, mm/s – 1 st stage | 25 | 25 | 25 | 25 |
| Closing speed, mm/s – 2 nd stage | 4.2 | 4.2 | 3.3 | 2.9 |
| Motor | 400V/2.2 kW | | | 400V/3 kW |
| ED, % | S 3-30% ¹ | | | |
| Weight, kg | 280 | 340 | 450 | 920 |

¹ maximum pressing capacity of 10 full load/full lift presses per hour

INFO

Intended use:

A workshop press/straightening press is a press with a slow closing speed of 25 mm/s and a maximum pressing capacity of 10 full load/full lift presses per hour.

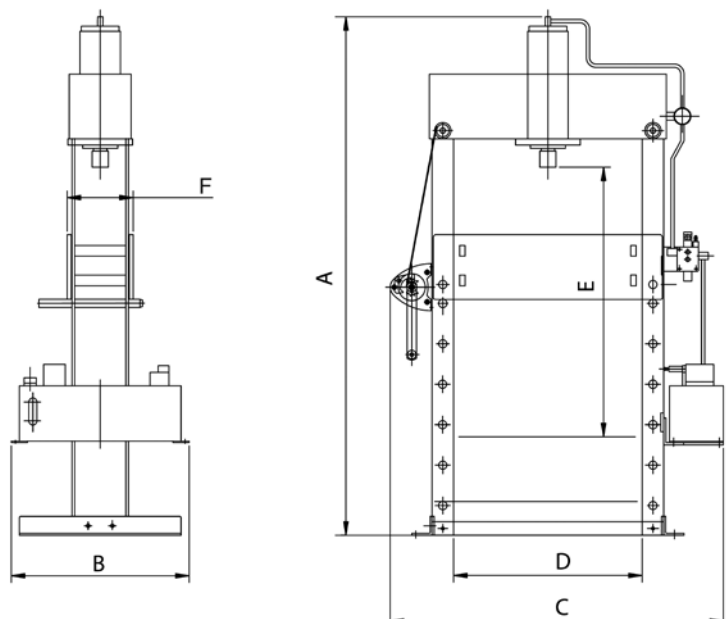

Accessories for workshop presses HWPHP and HWPEP

Technical data accessories - supporting plate

| Art.-No. | suitable for workshop press | Length mm | Width mm | Bore hole diameter mm |
|----------|-----------------------------|--------------|-------------|--------------------------|
| - | 15/20t ¹ | 240 | 240 | 20/25/35 |
| 40005478 | 30/40t | 240 | 290 | 20/25/35 |
| 40005479 | 50t | 350 | 320 | 20/25/35 |
| 40005480 | 100t | 420 | 300 | 20/25/35 |

¹included in scope of delivery

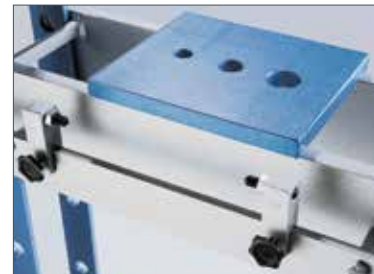

Technical data accessories - prism set

| Art.-No. | suitable for workshop press | Length mm | Width mm |
|----------|-----------------------------|--------------|-------------|
| - | 15/20t ¹ | 195 | 110 |
| 40005482 | 30/40t | 265 | 140 |
| 40005483 | 50t | 300 | 160 |
| 40005484 | 100t | 425 | 240 |

¹included in scope of delivery

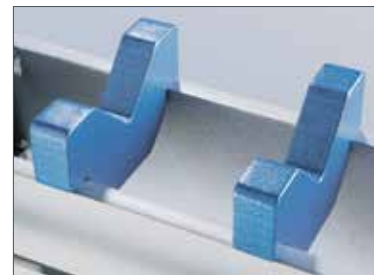

Technical data accessories - centering device

| Art.-No. | suitable for workshop press | Length mm |
|----------|-----------------------------|--------------|
| - | 15/20t ¹ | 650 |
| 40005485 | 30t | 650 |
| 40005486 | 40/50t | 900 |
| 40005487 | 100t | 1200 |

¹included in scope of delivery



Technical data accessories - pressing pin set

| Art.-No. | suitable for workshop press | Version | Diameter mm |
|------------|-----------------------------|---------|--------------------------------|
| 40005488 | 15 - 40t | 6-part | 12, 14, 16, 18, 20, 22 |
| 40005489 | 15 - 40t | 8-part | 12, 14, 16, 18, 20, 22, 25, 30 |
| N040005490 | 50 - 100t | 6-part | 12, 14, 16, 18, 20, 22 |
| N040005491 | 50 - 100t | 8-part | 12, 14, 16, 18, 20, 22, 25, 30 |





HRH P PROLINE Hydraulic service jack

Capacity 2 - 15 t

For lifting vehicles on one side (the lifted load must be secured mechanically with supporting stands, for example) and for lifting vehicles with a small ground clearance.

Features

- Quick-lift function as standard
- Controlling, lifting and lowering via the draw bar
- Integrated pressure control valve for a longer service life of the jack.



Technical data HRH P PROLINE

| Model | Art.-No. | Quick lift | Capacity t | Höhe min. mm | Height max. mm | Dimensions max L x W x H mm | Weight kg |
|--------------------------|----------|------------|---------------|-----------------|-------------------|-----------------------------------|--------------|
| HRH P 2,0 | 32345006 | X | 2 | 80 | 500 | 730 x 340 x 160 | 36 |
| HRH P 2,0 L ² | 32345005 | X | 2 | 90 | 500 | 950 x 340 x 126 | 41 |
| HRH P 3,0 H ¹ | 32346028 | X | 3 | 130 | 860 | 1620 x 460 x 210 | 88 |
| HRH P 4,0 | 32346001 | X | 4 | 145 | 560 | 1270 x 465 x 200 | 70 |
| HRH P 6,0 | 32347016 | X | 6 | 155 | 570 | 1395 x 470 x 210 | 90 |
| HRH P 8,0 H ¹ | 40016051 | X | 8 | 180 | 960 | 1830 x 475 x 350 | 160 |
| HRH P 10,0 | 32348004 | X | 10 | 170 | 670 | 1700 x 470 x 280 | 136 |
| HRH P 15,0 | 32349019 | X | 15 | 200 | 600 | 1790 x 475 x 325 | 162 |

H¹ = Lift-up jack L² = long

HRH S SILVERLINE Hydraulic service jack

Capacity 2 - 5 t

For lifting vehicles on one side (the lifted load must be secured mechanically with supporting stands, for example).

Features

- Quick-lift function as standard
- Integrated pressure control valve for a longer service life of the jack.
- Lockable pump lever



Technical data HRH S SILVERLINE

| Model | Art.-No. | Quick lift | Capacity t | Height min. mm | Height max. mm | Dimensions max L x W x H mm | Weight kg |
|-------------|----------|------------|---------------|-------------------|-------------------|-----------------------------------|--------------|
| HRH S 2,0 L | 40008532 | X | 2 | 140 | 800 | 1350 x 430 x 190 | 75 |
| HRH S 3,0 L | 40008533 | X | 3 | 125 | 605 | 1310 x 320 x 185 | 70 |
| HRH S 5,0 L | 40008534 | X | 5 | 145 | 560 | 1420 x 350 x 198 | 95 |



UB Supporting stand

Capacity 2 - 12 t

For mechanical support of lifted loads and for jacking-up loads which must be held for a long period of time.

Features

- Stamp with six height adjustments, locking with pin and cotter pin. For capacities above 12 t adjustment through threaded spindle.
- High level of stability.

Technical data UB

| Model | Art.-No. | Capacity t | Height min. mm | Height max. mm | Height adjustment mm | Raster points | Spread angle | Weight kg |
|---------|-----------|------------|----------------|----------------|----------------------|---------------|--------------|-----------|
| UB 2H | 192019922 | 2 | 505 | 755 | 250 | 5 | 3 x 120° | 6.6 |
| UB 3 | 192019936 | 3 | 346 | 510 | 164 | 5 | 3 x 120° | 4.7 |
| UB 5 | 192019941 | 5 | 406 | 567 | 161 | 5 | 3 x 120° | 7.2 |
| UB 8 | 192019946 | 8 | 424 | 633 | 209 | 5 | 3 x 120° | 11.5 |
| UB 8H | 192019951 | 8 | 605 | 870 | 265 | 6 | 3 x 120° | 15.0 |
| UB 12S | 192019953 | 12 | 320 | 500 | 180 | spindle | 4 x 90° | 11.6 |
| UB 12HS | 192019954 | 12 | 475 | 725 | 250 | spindle | 4 x 90° | 15.0 |

HAW S Hydraulic repair set

Pressing power 4 and 10 t

A useful tool for repairs on car/truck bodies for quick planishing, spreading and pressing with high loads.

Features

- Available in two versions for 4 t and 10 t.
- All parts are packed in a stable plastic case.



Technical data HAW S

| Model | Art.-No. | Pressing power t | Cylinder stroke mm | Weight kg |
|------------|----------|------------------|--------------------|-----------|
| HAW S 4,0 | 32453025 | 4 | 127 | 20.5 |
| HAW S 10,0 | 32457050 | 10 | 152 | 34.5 |



Returns – We need your support!

Dear Sirs,

COLUMBUS McKINNON Industrial Products GmbH manufactures worldwide according to uniform, controlled standards of EN ISO 9001. This is a guarantee for our business partners that given standards in design and development, manufacturing, assembly and service are complied with. In spite of all our efforts, should there still be a reason to complain about one of our products, we kindly ask you to inform before you return the goods to us. We will be happy to help you!

To organize returns as quickly and easy as possible we summarize the process in three steps:

Call us to receive a CMCO return delivery note

- Print out CMCO return delivery note
- Stick CMCO return delivery note on the outside of the package

This easy sequence will be valid for warranty returns, for service returns and for other return deliveries. In case the goods should be shipped directly from your end user we appreciate that you forward the CMCO return delivery note to your customer.

Please note that products can only be returned with our prior approval and must be accompanied by a CMCO return delivery note. Goods arriving without the return delivery note will not be accepted by our goods-in department.

In case of potential transport damage, a damage confirmation report provided by the forwarder is required by our insurance company. Please indicate potential transport damages immediately to your logistics partner and refuse acceptance.

If the reason for the return delivery is not within CMCO's responsibility or in case of unjustified complaint we - much to our regret - will have to pass on the costs to the customer. For costs arising for equipment being returned to stock and the necessary inspection, we will levy a restocking charge of 20%. The amount will be deducted from our credit memo after inspection and acceptance of the goods.

We thank you for your understanding!
Our sales team is available for any further questions.

Best regards,
COLUMBUS McKINNON Industrial Products GmbH

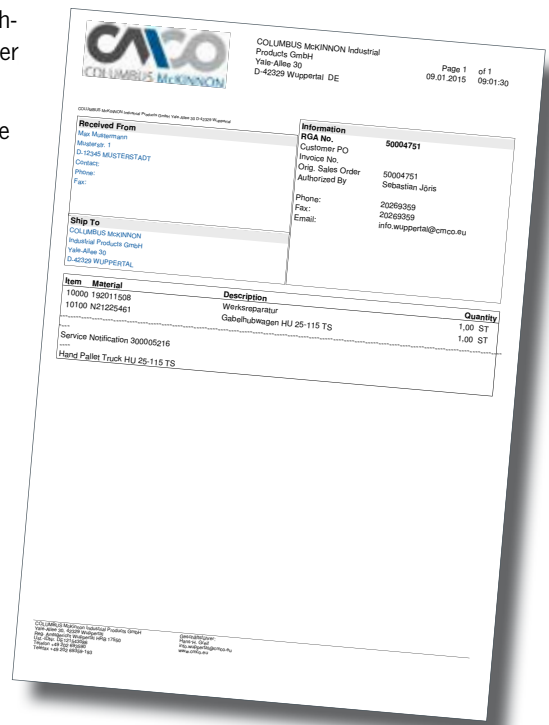

COLUMBUS MCKINNON Industrial Products GmbH

Yale-Allee 30
42329 Wuppertal
Phone: +49 (0) 202/693 59-0
Fax: +49 (0) 202/693 59-127
Web Site: www.cmco.eu, www.yale.de
e-mail: info.wuppertal@cmco.eu

COLUMBUS MCKINNON Engineered Products GmbH

Am Silberpark 2-8
86438 Kissing
Phone: +49 8233 2121-777
Fax: +49 (0) 82 33/21 21-805
Web Site: www.pfaff-silberblau.com
e-mail: sales.kissing@cmco.eu

Subject to engineering changes and improvements.
No warranty for printing errors or mistakes.
Effective October 2021.

Reproduction or reprinting of this catalogue can only
be carried out with written permission from
COLUMBUS MCKINNON Industrial Products GmbH.

PFAFF

silberblau

