



Case lifters help keep sick days down

Workstation designers are increasingly aware of the importance of ergonomics on the job. Musculoskeletal disorders are among the primary causes for worker absences. In order to sustainably reduce times absent due to sickness and disability, it is important to minimize the strain placed on workers' bodies.

Workers who continuously and repetitively lift and lower loads are especially prone to incorrect work posture that can lead to overexertion. Bending of the torso (below 800 mm) places a disproportionate strain on the human body. The electric case lifter literally takes the load off employees' backs by doing the raising and lowering for them. It serves to bring workpieces into the correct grab area or to deliver finished products directly to dollies for further transport. In particular where heavy loads are involved, the case lifter is a great help in supplying materials to the workstation. It can also be positioned at the beginning or end of a conveyor track to feed or remove conveyed items.

Moreover, it slashes the time required for parts supply and removal by up to 68% (MTM – Method of Time Measurement). Employees can then concentrate their efforts on their value-adding assembly work.

Rexroth's case lifter offers you many advantages, including the following:

- ▶ Compared with manual mode, automatic mode further reduces waiting times
- ▶ In addition to stationary operation, rollers also allow for semi-mobile use
- ▶ Suitable for loads up to 220 kg
- ▶ Space-saving thanks to the compact, closed aluminum housing
- ▶ Suitable for use in ESD-sensitive areas
- ▶ The 10 mm slot enables simple mounting of components from the Basic Mechanic Elements modular system

CASE LIFTER OVERVIEW

Electric case lifter
Accessories



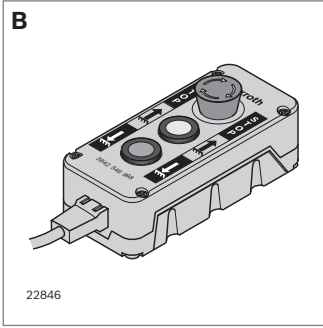

Basic hand switch (B)

- ▶ Push button for manual lifting and lowering
- ▶ With emergency stop
- ▶ Can be replaced with Comfort hand switch (D)
- ▶ Not suitable for oily environments, solution on request

		No.
B	Basic hand switch	3 842 546 998

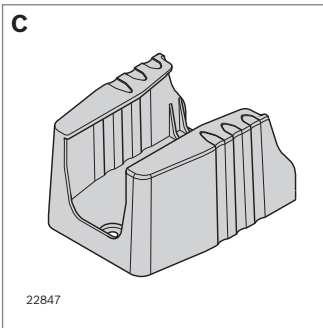

Holder for hand switch (C)

- ▶ To stow Basic and Comfort hand switches

Scope of delivery: Includes fastening material for 10 mm slot

		No.
C	Holder for hand switch	3 842 548 038

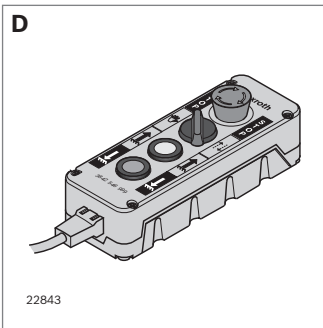

Comfort hand switch (D)

- ▶ For selection of "Manual" or "Automatic" mode
- ▶ Push button for manual lifting and lowering in "Manual" mode
- ▶ With emergency stop
- ▶ Not suitable for oily environments, solution on request

		No.
D	Comfort hand switch	3 842 546 999

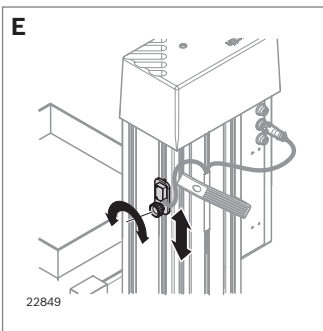

Comfort sensor unit (E)

- ▶ Works with the Comfort hand switch to control stacking and de-stacking in automatic mode

Scope of delivery: Includes fastening material for 10 mm slot

		ESD	No.
E	Comfort sensor unit	⚡	3 842 547 200

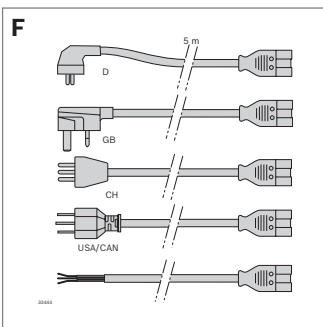

Mains cable (F)

- ▶ Ready-to-use; for simple, secure plug-and-play installation

		L (m)	No.
F	HD mains cable	D/F	5 3 842 554 183
		GB	5 3 842 555 603
		CH	5 3 842 555 605
		Open end	5 3 842 555 607
		Mains cable	USA/CAN*

*UL and CSA test marks

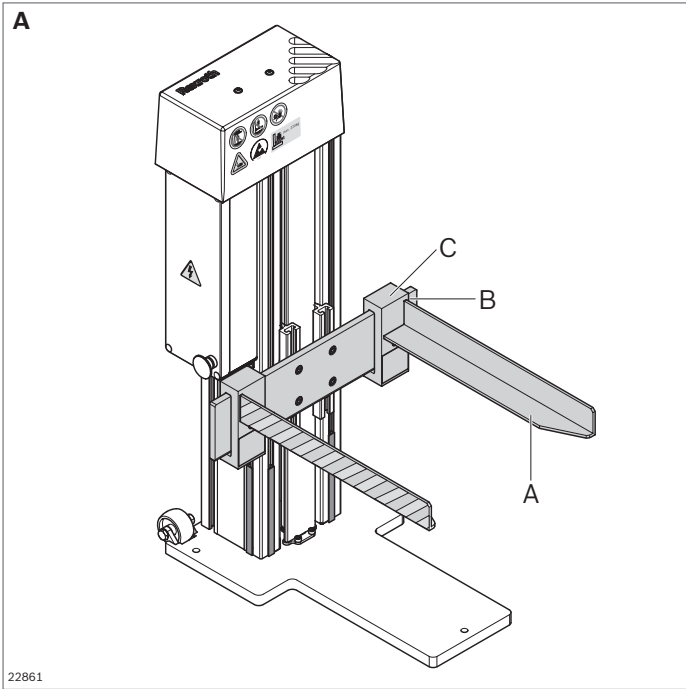

Case lifter – accessories

Forks (A)

- For support of containers (A1) or dollies (A2)

Material: Steel; powder-coated; black, with yellow safety mark on the side

Scope of delivery: Kit with two forks (left and right), incl. fastening material

	L (mm)	ESD	No.
A Forks	400		3 842 549 435
	600		3 842 549 442

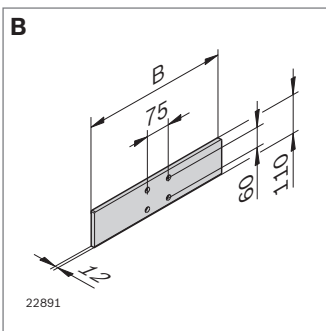
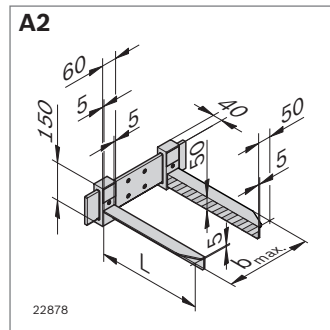
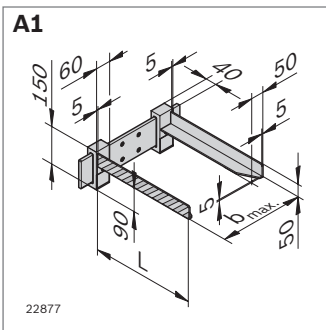

Attachment plate (B)

- For attaching forks or suspension straps
- Suitable for all case lifters

Material: Steel, galvanized

Scope of delivery: Includes fastening material (with case lifter)

	B (mm)	b _{max} (mm)	ESD	No.
B Attachment plate	450	400		3 842 549 427
	650	600		3 842 549 428

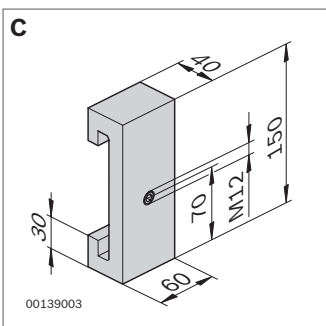

Suspension strap (C)

- Suitable for attachment plate B
- For attaching individual supports

Material: Steel; preserved

Scope of delivery: Incl fastening material

		ESD	No.
C Suspension strap	Set		3 842 549 449

D

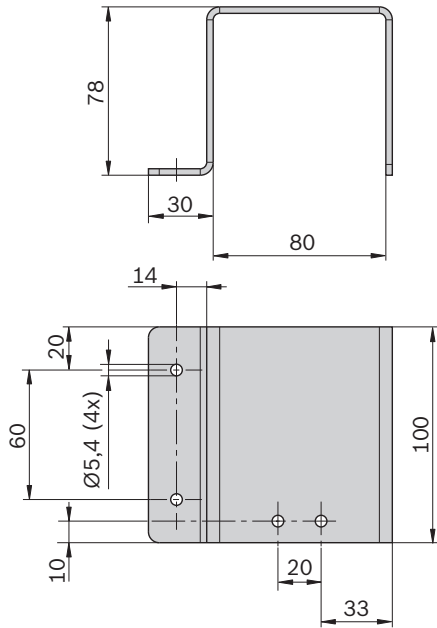

39372

Protective sheet (D)

- ▶ Protective sheet for rear of case lifter
- ▶ Additional robust impact protection for plug connections (hand switch and sensor unit)

Material: Aluminum, anodized

Scope of delivery: Includes fastening material for 10 mm slot

	No.
D Protective sheet	3 842 564 128

