

45° ANGLE TRANSFER

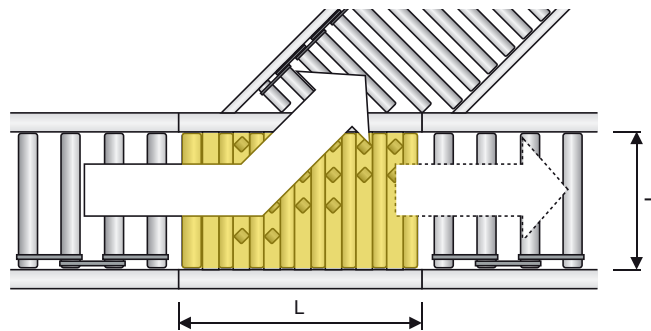

Itoh-Denki Pop-Up transfer modules use 24V DC Brushless Motorized Roller technology in a very compact « cassette » structure. This makes it easy to integrate into both new and reconditioned conveyors. It can be used on conveyor lines for order picking, distribution or on assembly lines to adapt to your logistics changes.



ADVANTAGES

HIGH CAPACITY TRANSFER

Three compact and powerful brushless motorized rollers provide efficient and maintenance free operation. The speed of movement ensures a high capacity of loads to be sorted.

MONOENERGY AND ECONOMICAL

Pop-Up requires a 24V DC supply only. Only two motors operate simultaneously and consume 160W at nominal speed.

COMPACT AND LIGHT

The Pop-Up diverter is a compact system (169mm high) and is one of the lightest modules on the market.

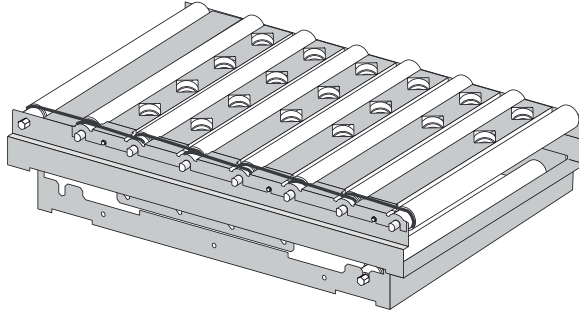

ENVIRONMENT

Pop-Up operates without pneumatic or oil, allowing a clean and quieter environment.

QUICK AND EASY TO INSTALL

The compact and light cassette makes it easy to integrate the Pop-Up diverter in new or existing conveyor systems. This complete transfer table is mounted with only 4 screws.

MODULAR

Our product offers various application possibilities. It can be easily moved on the conveyor line to fit your logistics development.

TRANSFER CAPACITY

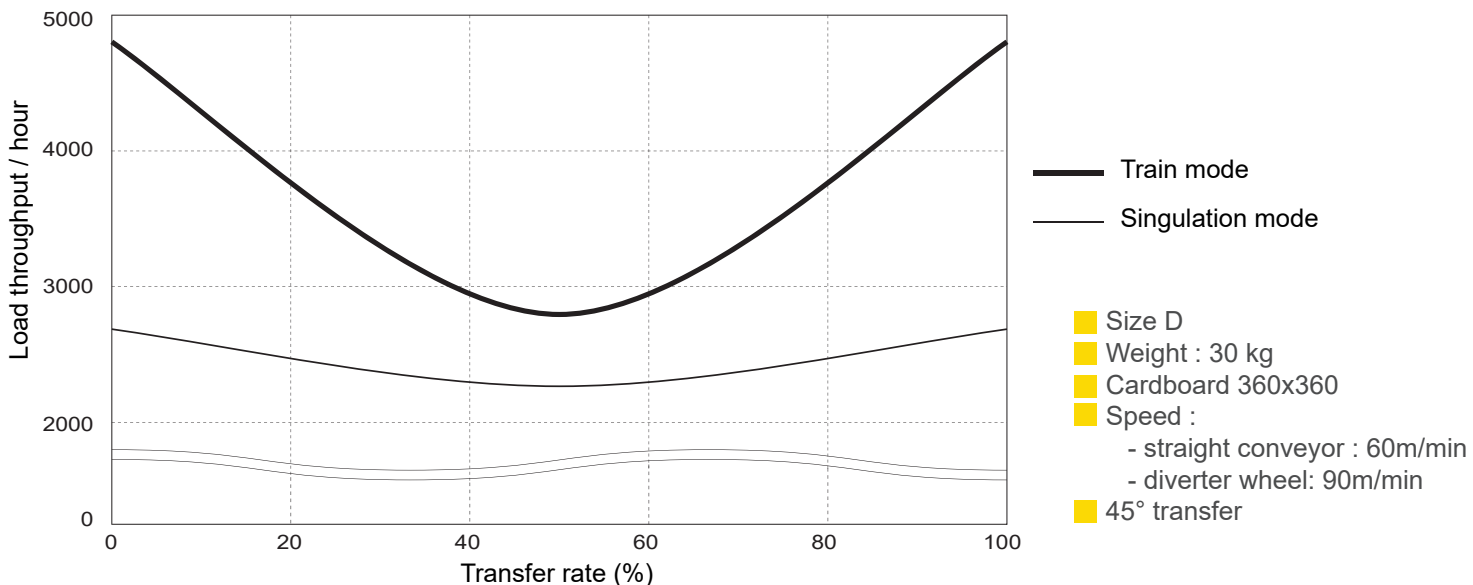

The load throughput depends on the size and material of the package to be transported, as well as speed, transfer mode, transfer rate...

The diagram is given as an indication.

STRUCTURES AND DIMENSIONS

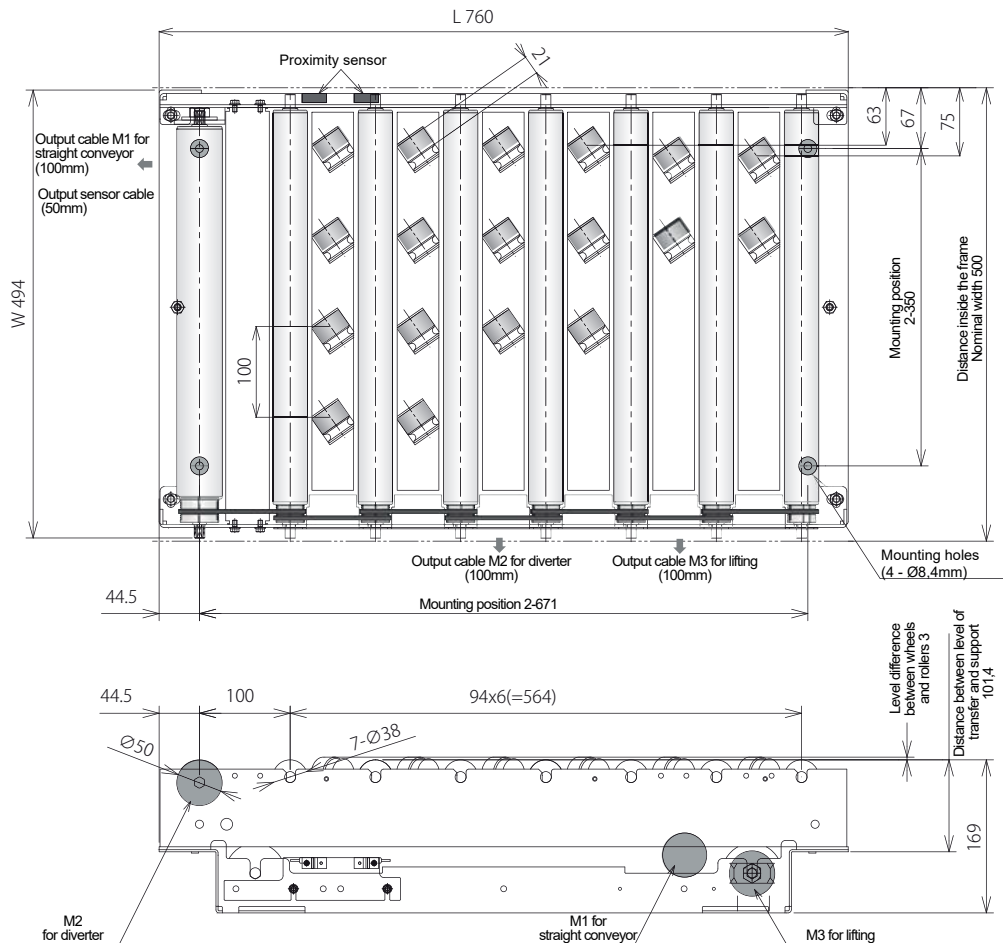

GENERAL TECHNICAL DATA

Size		A	B	C	D
Dimension WxLxH (mm)	Width W (mm)	394	494	594	694
	Length L (mm)	760			
	Height H (mm)	169			
Frame width mini (mm)		400	500	600	700
Load dimensions WxL (mm)	Mini	300x300			
	Max.	300x650	400x650	500x650	600x650
Max load to be conveyed (Kg)		30			
Number of diverter wheels		14	18	18	24
Number of transfer free rollers		7			
Transfer angle		45° (30° option)			
Transfer direction		Right or left (to specify)			
Weight (Kg)		46	49	51	54

TRANSFER TO LEFT

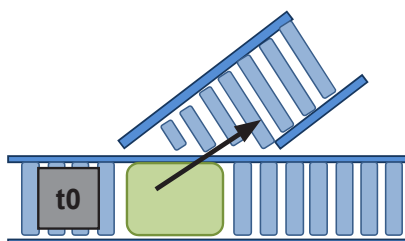

TRANSFER TO RIGHT

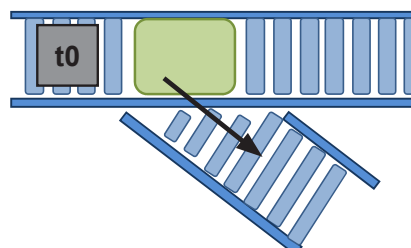

The informations in this document are indicative and could be modified.

CONTROL

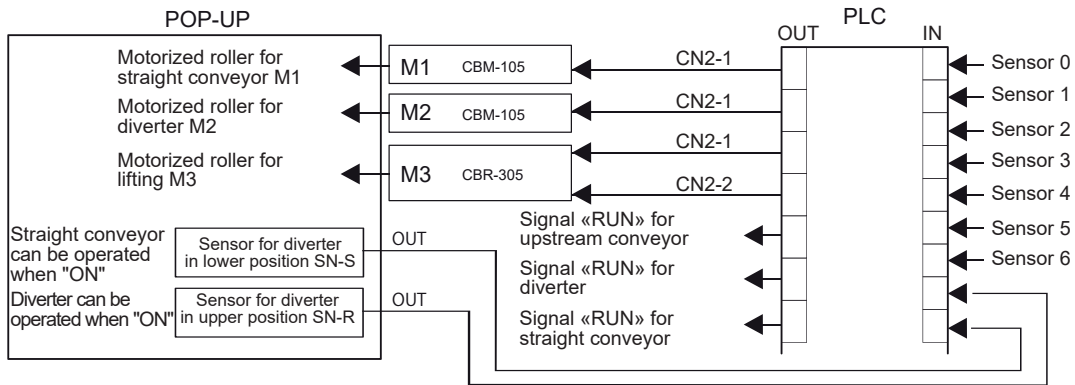
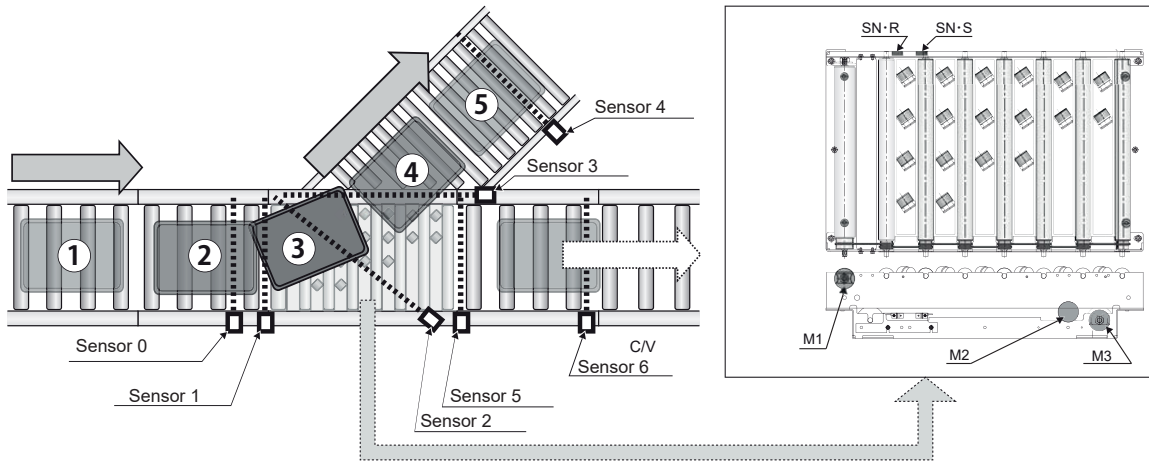

REFERENCES

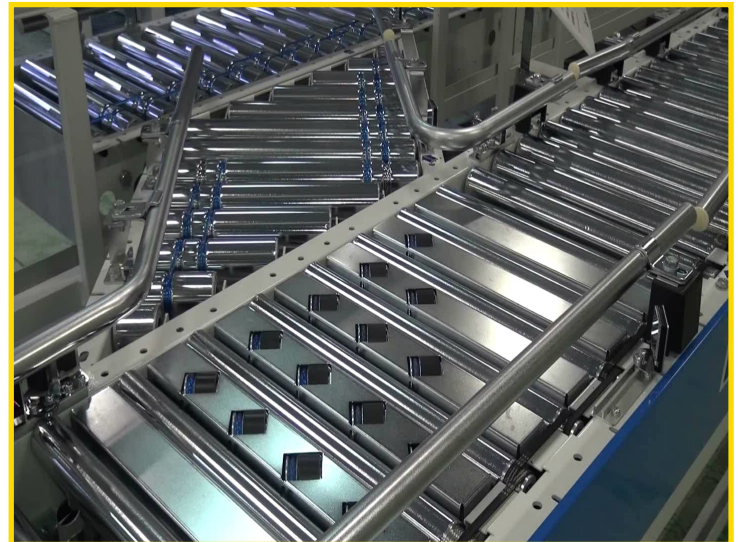
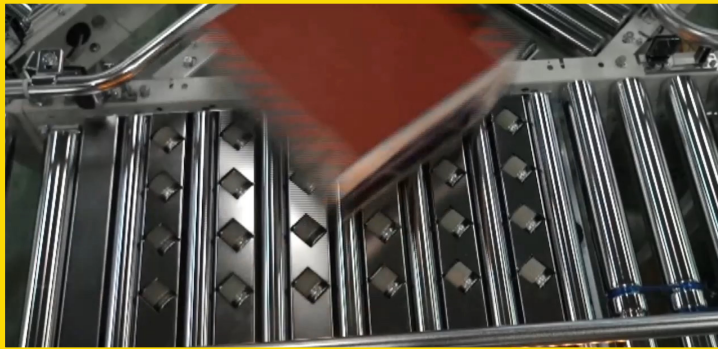

CONTACTS

ITOH DENKI EUROPE S.A.S.

490 Av. des Jourdiés
 P.A.E. les Jourdiés
 74800 St Pierre en Faucigny - France
 Tél. : +33 (0)4 50 03 09 99
 Fax : +33 (0)4 50 03 07 60
 E-mail : info@itoh-denki.com

SUCCURSALE ITOH DENKI ANGLETERRE

Suite 1 Trinity Space Centre
 Waldorf Way
 Wakefield WF2 8DH - UK
 Tel : +44 (0)1924 366 539
 Fax : +33 (0)4 50 03 07 60
 E-mail : info@itoh-denki.com

SUCCURSALE ITOH DENKI ALLEMAGNE

Neumeyerstrabe 48
 90411 NÜRNBERG - Deutschland
 Tel : +49 911 25 26 - 200
 Fax : +49 911 25 26 - 201
 E-mail : info@itoh-denki.de