

CIRCUIT BOARD
HB510N / BN
HB510P / BP

TECHNICAL DOCUMENTATION

SUMMARY

1. Presentation of the PowerMoller range	Page 3
2. Presentation of the circuit board	Page 4
<i>General description</i>	
<i>Dimensions</i>	
<i>General specifications</i>	
<i>Electric diagram</i>	
3. Technical data depending on the motorized roller	Page 6
<i>With PM500FE (50E) / PM500FE-B (50EB) motorized roller</i>	
<i>With PM605FE (60E) / PM605FE-B (60EB) motorized roller</i>	
<i>With PM500FP motorized roller (50P)</i>	
4. Location and specifications of items	Page 12
<i>Location of items</i>	
<i>Specifications of connectors</i>	
<i>Connector CN1 - 24 VDC power supply</i>	
<i>Connector CN2 - Input / Output (E/S)</i>	
<i>Connector CN3 - Sensor</i>	
<i>Connectors CN4 et CN5 - Communication cable</i>	
<i>Connector CN6 - Motor</i>	
<i>Led1, Led2 and Led3</i>	
<i>Dip-switch SW1 - Selection and configuration of functions</i>	
<i>Dip-switch SW2 - Selection and configuration of functions</i>	
<i>SW3 - Selection fixed speed</i>	
5. Temporisations	Page 21
<i>Run holding timer</i>	
<i>Sensor timer</i>	
<i>Jam timer</i>	
<i>Initialisation</i>	
6. Functions and settings	Page 24
<i>Transfer modes</i>	
<i>Synchronisation</i>	
<i>«Forced start» function</i>	
<i>«Forced stop» function</i>	
7. Block creation	Page 29
<i>Setting logic flow direction relative to load move direction</i>	
<i>Setting motorized rotation direction relative to logic flow direction</i>	
<i>Speed variation</i>	
<i>Setting internal speed by rotary switch SW3</i>	
<i>External speed control by analogic voltage 0-10V</i>	
<i>Internal and external speed variation</i>	
<i>Error signal recovery</i>	
<i>Individual management</i>	
<i>Block management</i>	
<i>Implementation of several functions in the same block</i>	
Recommended setting order	Page 38
Appendix 1: Incorporation declaration	Page 39

1 - PRESENTATION OF THE POWER MOLLER® PRODUCT RANGE

POWER MOLLER®

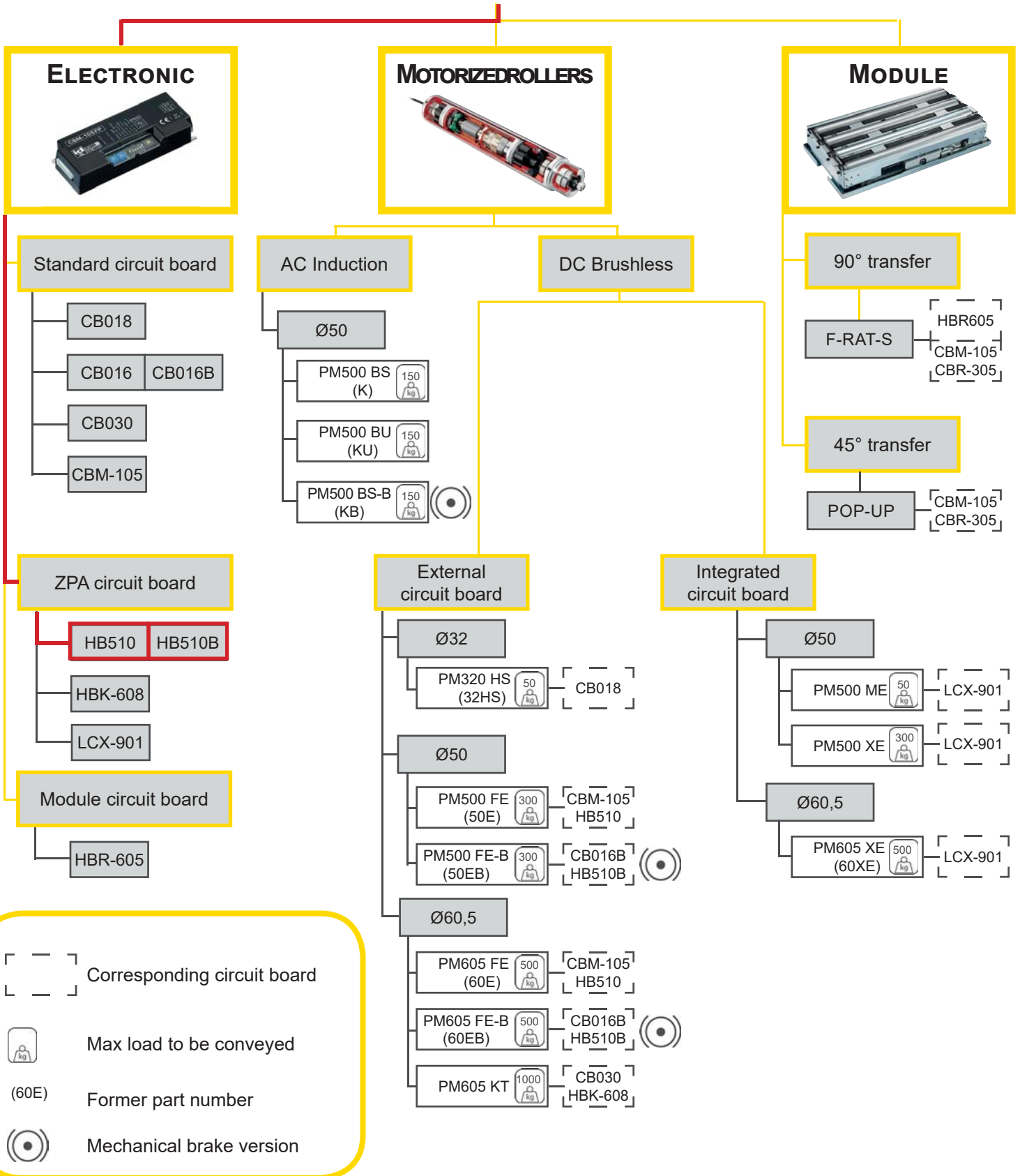

- [- -] Corresponding circuit board
- Max load to be conveyed
- (60E) Former part number
- Mechanical brake version

2. PRESENTATION OF THE CIRCUIT BOARD

GENERAL DESCRIPTION



- ⇒ PNP version without brake : HB510P
- ⇒ NPN version without brake : HB510N

- ⇒ PNP version with brake : HB510BP
- ⇒ NPN version with brake: HB510BN

- Fasteners
 - 4 M4 x 15 cross-head screws
 - 4 M4 washers
 - 4 M4 nuts
- 1 connector WAGO 734-102 (2 points)
- 1 connector WAGO 733-105 (5 points) (in option)
- 1 connector WAGO 733-103 (3 points)
- 1 communication cable

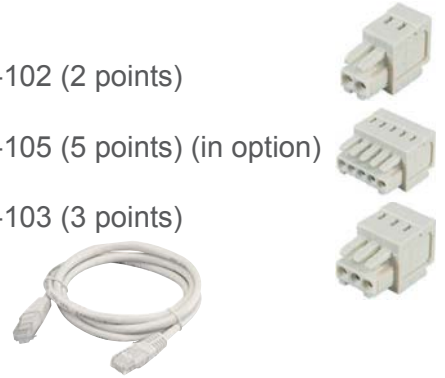

Compatible motorized rollers series:
 Serie PM500FE (50E) / PM500FE-B (50EB)
 Serie PM605FE (60E) / PM605FE-B (60EB)
 Serie PM500FP (50P)
 Serie PM500FS (50) / PM500FS-B (50B) (Old range)

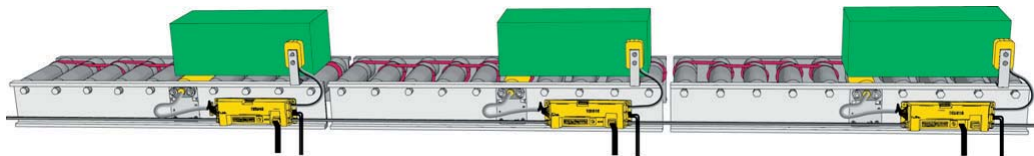
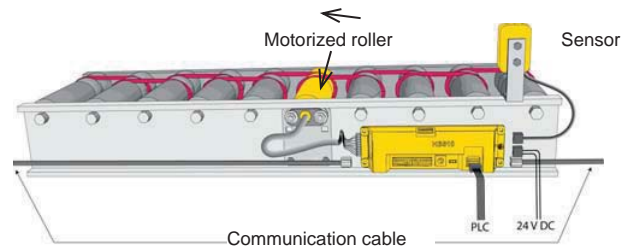

The circuit board HB510 must be associated with only one motor :
1 Power Moller® 24 brushless = 1 HB510

! The circuit board HB510 is not compatible with others circuit board type HBxxx.

DIMENSIONS

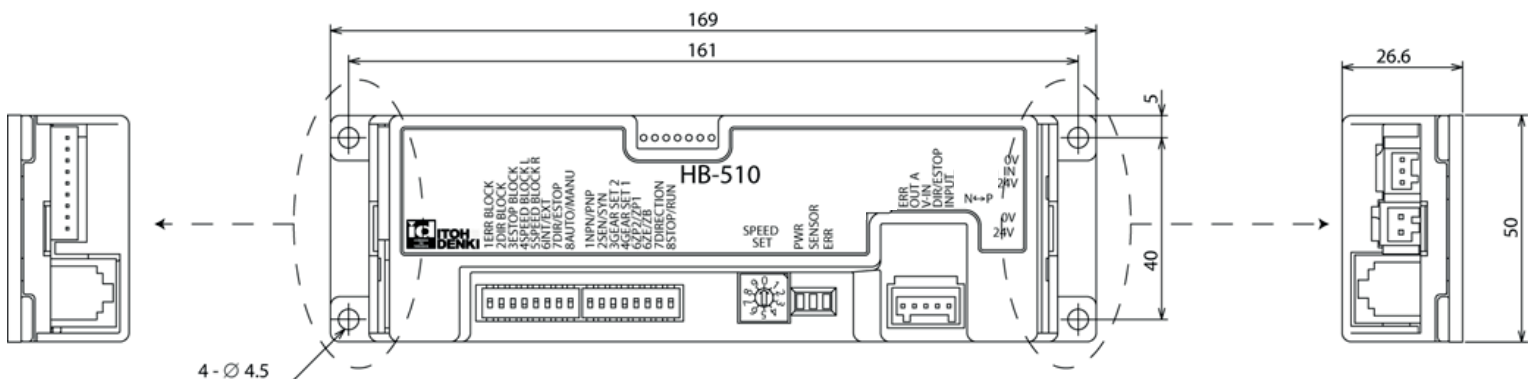

GENERAL SPECIFICATIONS

Nominal voltage	24VDC \pm 10%
Input current without motorized roller	0.06A
Input power without motorized roller	1.5W
Current limitation	4A
Motor acceleration time	200ms
Protection index	IP20
Protection	Integrated 5A fuse Against inversion of polarity (24 V and 0 V) Thermal protection (70°C for the circuit board, 105°C for the motor)
Input voltage on connector CN2 if different to 0 or 24V	< 1V for NPN > 15V for PNP
Sensor input (sensor not supplied)	NO contact (normally open), 24 V, max. 35 mA

Power supply	TBTS 24VDC \pm 10% - ripple < 10% A stabilised power supply is recommended
Environment	Temperature range 0 / +40 °C Relative humidity < 90% condensation-free (avoid thermal shocks) Neither corrosive nor explosive atmosphere Vibrations <0.5 G Indoor use CE marking in accordance with EMC directive 89/336/EEC
Degree of protection	The circuit board must be protected against impacts and against water and dust ingress, as appropriate for its environment (UTE C 15-103 : 97 ou HD 384.3S2 : 95 et 384.5-51S2 : 96)

ELECTRIC DIAGRAM

PNP (HB510P / HB510BP)

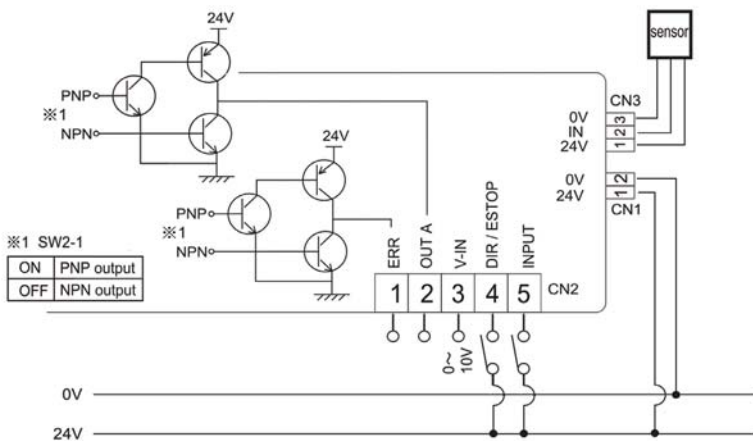

NPN (HB510N / HB510BN)

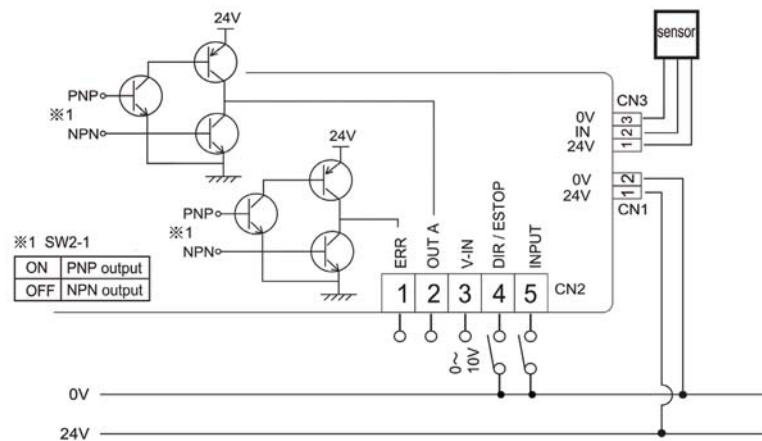

3. TECHNICAL DATAS ACCORDING MOTORIZED ROLLER

CHARACTERISTIC WITH PM500FE (50E) / PM500FE-B (50EB) MOTORIZED ROLLER

PM500FE (50E) / PM500FE-B (50EB) Speed code 55

S (m/min) +/- 3%		Speed selection		Tangential force (N)		Torque (Nm)		Current (A)		
No load	Nominal	Internal SW3	By external voltage (V)	Nominal	Start-up	Nominal	Start-up	No load	Nominal	Start-up
61,7	49,4	9	9,5+/-0,2	37,9	111,8	0,9	2,8	0,6	2,5	4,0
56,6	49,4	8	8,5+/-0,2	37,9		0,9		0,6	2,5	
51,4	49,4	7	7,5+/-0,2	37,9		0,9		0,5	2,5	
46,3	46,3	6	6,5+/-0,2	38,2		1,0		0,5	2,5	
41,1	41,1	5	5,5+/-0,2	38,6		1,0		0,4	2,5	
36,0	36,0	4	4,5+/-0,2	39,0		1,0		0,4	2,1	
30,9	30,9	3	3,5+/-0,2	39,4		1,0		0,4	1,9	
25,7	25,7	2	2,5+/-0,2	39,8		1,0		0,3	1,7	
20,6	20,6	1	1,5+/-0,2	40,1		1,0		0,3	1,5	
15,4	15,4	0	0,5+/-0,2	40,6		1,0		0,2	1,2	

Reduction ratio : 1/12,64

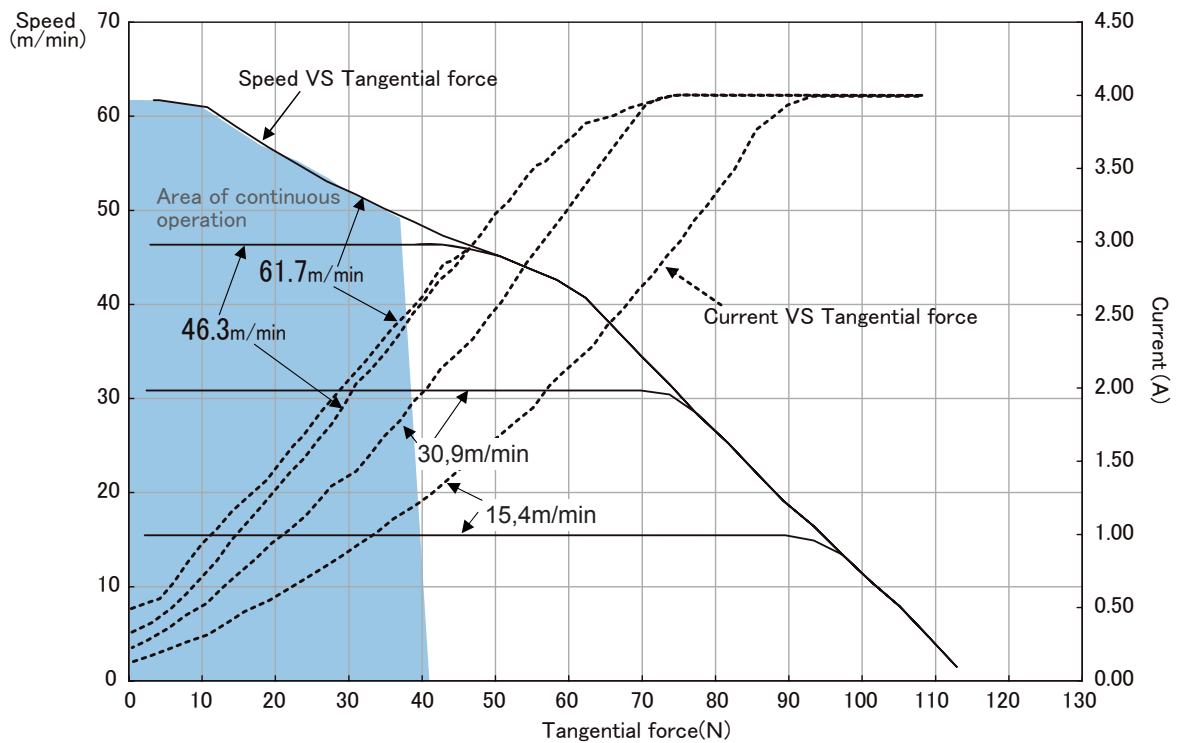

PM500FE (50E) / PM500FE-B (50EB) Speed code 25

S (m/min) +/- 3%		Speed selection		Tangential force (N)		Torque (Nm)		Current (A)		
No load	Nominal	Internal SW3	By external voltage (V)	Nominal	Start-up	Nominal	Start-up	No load	Nominal	Start-up
29,3	26,3	9	9,5+/-0,2	67,7	225,5	1,7	5,6	0,8	2,6	4,0
26,8	26,3	8	8,5+/-0,2	67,7		1,7		0,7	2,6	
24,4	24,4	7	7,5+/-0,2	68,3		1,7		0,6	2,5	
21,9	21,9	6	6,5+/-0,2	69,3		1,7		0,6	2,5	
19,5	19,5	5	5,5+/-0,2	70,1		1,8		0,5	2,3	
17,1	17,1	4	4,5+/-0,2	71,1		1,8		0,5	2,1	
14,6	14,6	3	3,5+/-0,2	72,2		1,8		0,4	1,8	
12,2	12,2	2	2,5+/-0,2	73,0		1,8		0,4	1,6	
9,8	9,8	1	1,5+/-0,2	74,0		1,9		0,3	1,4	
7,3	7,3	0	0,5+/-0,2	75,0		1,9		0,3	1,2	

Reduction ratio : 1/26,67

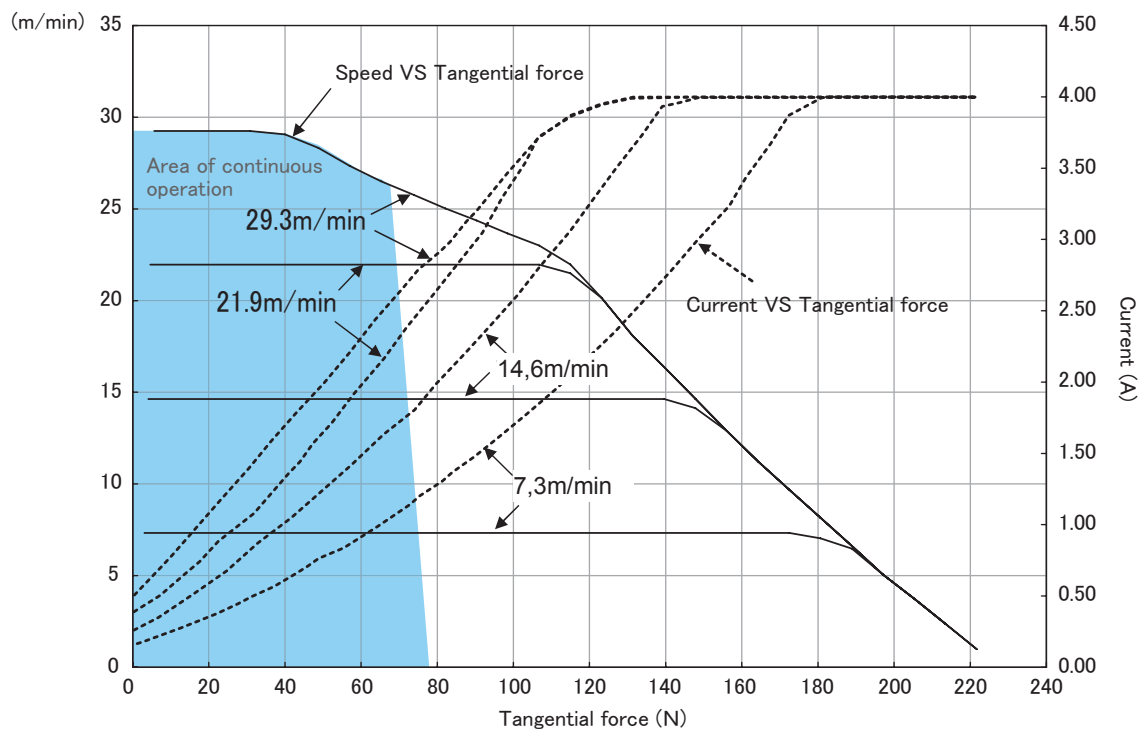

PM500FE (50E) / PM500FE-B (50EB) Speed code 15

S (m/min) +/- 3%		Speed selection		Tangential force (N)		Torque (Nm)		Current (A)		
No load	Nominal	Internal SW3	By external voltage (V)	Nominal	Start-up	Nominal	Start-up	No load	Nominal	Start-up
17,4	13,9	9	9,5+/-0,2	118,6	349,8	3,0	8,7	0,6	2,5	4,0
15,9	13,9	8	8,5+/-0,2	118,6		3,0		0,6	2,5	
14,5	13,9	7	7,5+/-0,2	118,6		3,0		0,5	2,5	
13,0	13,0	6	6,5+/-0,2	119,5		3,0		0,5	2,5	
11,6	11,6	5	5,5+/-0,2	120,7		3,0		0,4	2,5	
10,1	10,1	4	4,5+/-0,2	122,0		3,0		0,4	2,1	
8,7	8,7	3	3,5+/-0,2	123,2		3,1		0,4	1,9	
7,2	7,2	2	2,5+/-0,2	124,4		3,1		0,3	1,7	
5,8	5,8	1	1,5+/-0,2	125,6		3,1		0,3	1,5	
4,3	4,3	0	0,5+/-0,2	127,1		3,2		0,2	1,2	

Reduction ratio : 1/44,90

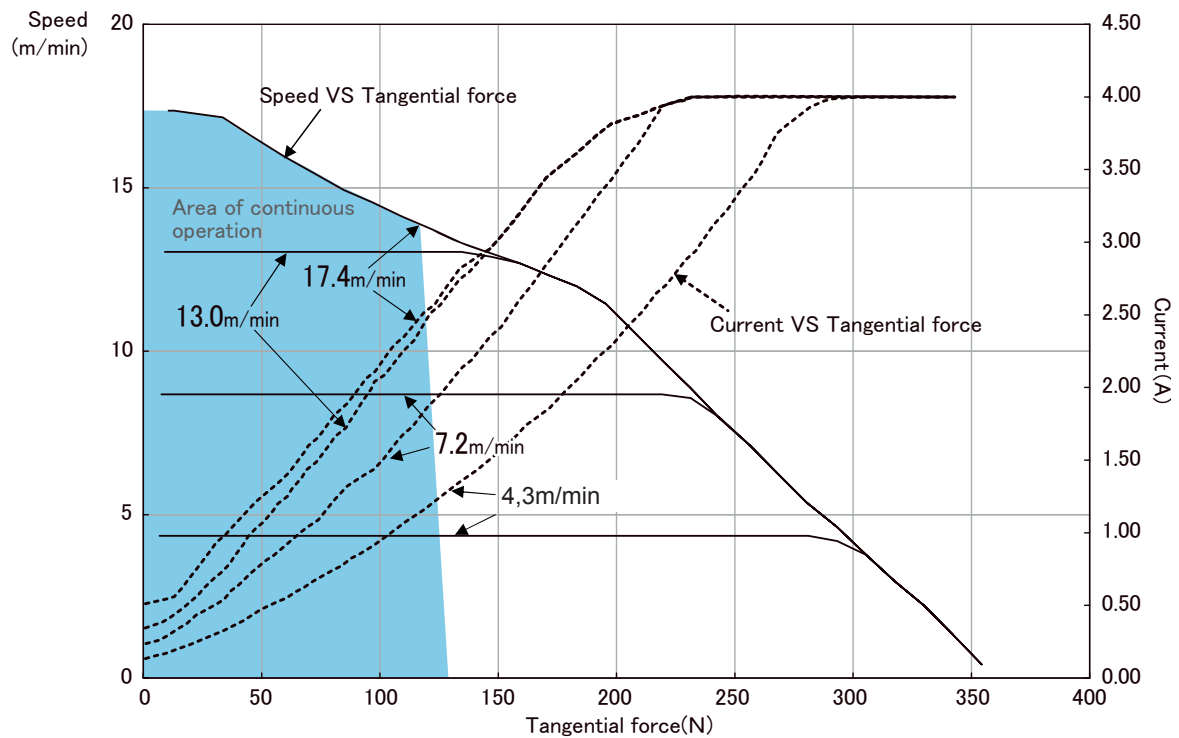

CHARACTERISTIC WITH PM605FE (60E) / PM605FE-B (60EB) MOTORIZED ROLLER

PM605FE (60E) / PM605FE-B (60EB) Speed code 55

S (m/min) +/- 3%		Speed selection		Tangential force (N)		Torque (Nm)		Current (A)		
No load	Nominal	Internal SW3	By external voltage (V)	Nominal	Start-up	Nominal	Start-up	No load	Nominal	Start-up
74,7	59,8	9	9,5+/-0,2	31,3	92,4	0,7	2,3	0,6	2,5	4,0
68,5	59,8	8	8,5+/-0,2	31,3		0,7		0,6	2,5	
62,2	59,8	7	7,5+/-0,2	31,3		0,7		0,5	2,5	
56,0	56,0	6	6,5+/-0,2	31,6		0,8		0,5	2,5	
49,7	49,7	5	5,5+/-0,2	31,9		0,8		0,4	2,5	
43,6	43,6	4	4,5+/-0,2	32,2		0,8		0,4	2,1	
37,4	37,4	3	3,5+/-0,2	32,6		0,8		0,4	1,9	
31,1	31,1	2	2,5+/-0,2	32,9		0,8		0,3	1,7	
24,9	24,9	1	1,5+/-0,2	33,1		0,8		0,3	1,5	
18,6	18,6	0	0,5+/-0,2	33,6		0,8		0,2	1,2	

Reduction ratio : 1/12,64

PM605FE (60E) / PM605FE-B (60EB) Speed code 25

S (m/min) +/- 3%		Speed selection		Tangential force (N)		Torque (Nm)		Current (A)		
No load	Nominal	Internal SW3	By external voltage (V)	Nominal	Start-up	Nominal	Start-up	No load	Nominal	Start-up
35,5	31,8	9	9,5+/-0,2	56,0	186,4	1,4	4,6	0,8	2,6	4,0
32,4	31,8	8	8,5+/-0,2	56,0		1,4		0,7	2,6	
29,5	29,5	7	7,5+/-0,2	56,4		1,4		0,6	2,5	
26,5	26,5	6	6,5+/-0,2	57,3		1,4		0,6	2,5	
23,6	23,6	5	5,5+/-0,2	57,9		1,5		0,5	2,3	
20,7	20,7	4	4,5+/-0,2	58,8		1,5		0,5	2,1	
17,7	17,7	3	3,5+/-0,2	59,7		1,5		0,4	1,8	
14,8	14,8	2	2,5+/-0,2	60,3		1,5		0,4	1,6	
11,9	11,9	1	1,5+/-0,2	61,2		1,6		0,3	1,4	
8,8	8,8	0	0,5+/-0,2	62,0		1,6		0,3	1,2	

Reduction ratio : 1/26,67

PM605FE (60E) / PM605FE-B (60EB) Speed code 15

S (m/min) +/- 3%		Speed selection		Tangential force (N)		Torque (Nm)		Current (A)		
No load	Nominal	Internal SW3	By external voltage (V)	Nominal	Start-up	Nominal	Start-up	No load	Nominal	Start-up
21,1	16,8	9	9,5+/-0,2	98,0	289,1	2,5	7,2	0,6	2,5	4,0
19,2	16,8	8	8,5+/-0,2	98,0		2,5		0,6	2,5	
17,5	16,8	7	7,5+/-0,2	98,0		2,5		0,5	2,5	
15,7	15,7	6	6,5+/-0,2	98,8		2,5		0,5	2,5	
14,0	14,0	5	5,5+/-0,2	99,8		2,5		0,4	2,5	
12,2	12,2	4	4,5+/-0,2	100,8		2,5		0,4	2,1	
10,5	10,5	3	3,5+/-0,2	101,8		2,6		0,4	1,9	
8,7	8,7	2	2,5+/-0,2	102,8		2,6		0,3	1,7	
7,0	7,0	1	1,5+/-0,2	103,8		2,6		0,3	1,5	
5,2	5,2	0	0,5+/-0,2	105,0		2,6		0,2	1,2	

Reduction ratio : 1/44,90

CHARACTERISTIC WITH PM500FP (50P) MOTORIZED ROLLER

PM500FP (50P) Speed code 55

S (m/min) +/- 3%		Speed selection		Tangential force (N)		Torque (Nm)		Current (A)		
No load	Nominal	Internal SW3	By external voltage (V)	Nominal	Start-up	Nominal	Start-up	No load	Nominal	Start-up
67,0	56,6	9	9,5+/-0,2	42,8	136,1	1,1	3,4	0,9	3,2	4,0
61,4	56,6	8	8,5+/-0,2	42,8		1,1		0,8	3,2	
55,8	55,8	7	7,5+/-0,2	42,9		1,1		0,8	3,2	
50,3	50,3	6	6,5+/-0,2	43,2		1,1		0,7	3,0	
44,7	44,7	5	5,5+/-0,2	43,5		1,1		0,6	2,8	
39,1	39,1	4	4,5+/-0,2	43,9		1,1		0,6	2,5	
33,5	33,5	3	3,5+/-0,2	44,3		1,1		0,5	2,2	
27,9	27,9	2	2,5+/-0,2	44,7		1,1		0,5	1,9	
22,3	22,3	1	1,5+/-0,2	45,1		1,1		0,4	1,6	
16,8	16,8	0	0,5+/-0,2	45,5		1,1		0,3	1,4	

Reduction ratio : 1/11,64

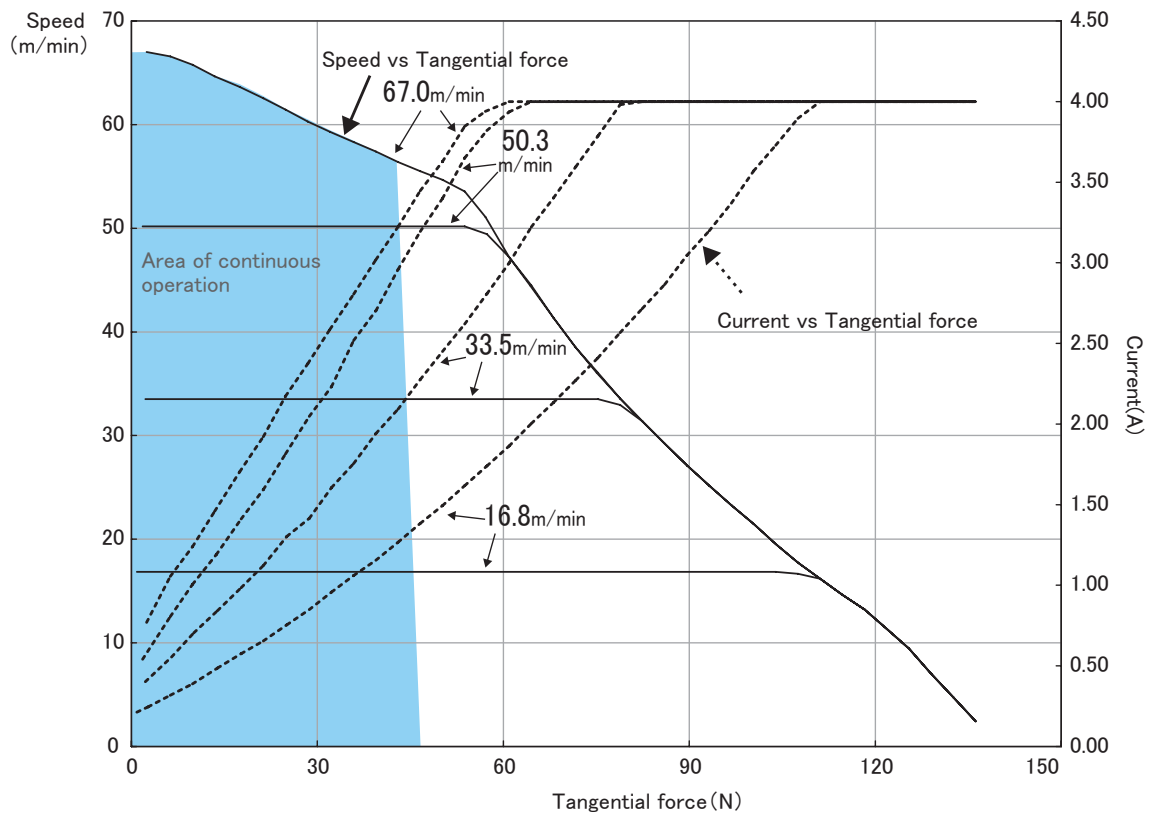

PM500FP (50P) Speed code 15

S (m/min) +/- 3%		Speed selection		Tangential force (N)		Torque (Nm)		Current (A)		
No load	Nominal	Internal SW3	By external voltage (V)	Nominal	Start-up	Nominal	Start-up	No load	Nominal	Start-up
17,8	15,0	9	9,5+/-0,2	142,1	452,1	3,6	11,3	0,9	3,2	4,0
16,3	15,0	8	8,5+/-0,2	142,1		3,6		0,8	3,2	
14,8	14,8	7	7,5+/-0,2	142,4		3,6		0,8	3,2	
13,3	13,3	6	6,5+/-0,2	143,4		3,6		0,7	3,0	
11,8	11,8	5	5,5+/-0,2	144,7		3,6		0,6	2,8	
10,4	10,4	4	4,5+/-0,2	146,0		3,6		0,6	2,5	
8,9	8,9	3	3,5+/-0,2	147,2		3,7		0,5	2,2	
7,4	7,4	2	2,5+/-0,2	148,5		3,7		0,5	1,9	
5,9	5,9	1	1,5+/-0,2	149,8		3,7		0,4	1,6	
4,4	4,4	0	0,5+/-0,2	151,1		3,8		0,3	1,4	

Reduction ratio : 1/43,95

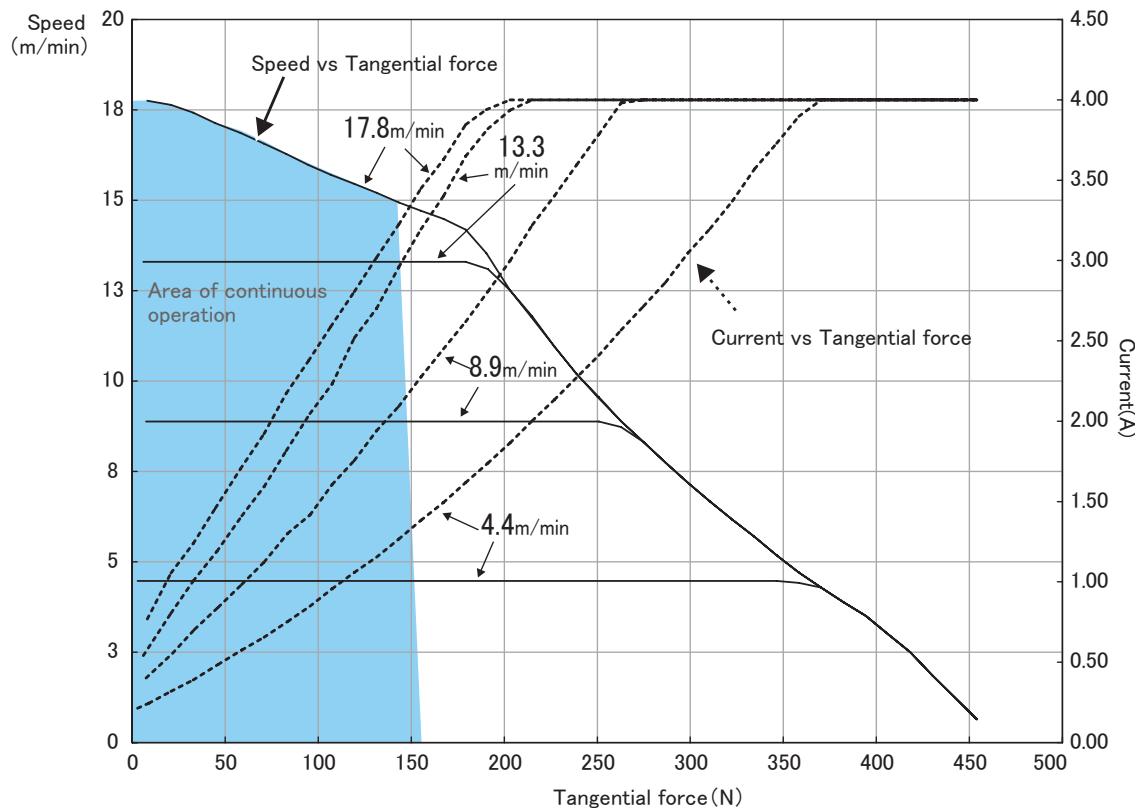

■ CN1 CONNECTOR - 24 VDC POWER SUPPLY

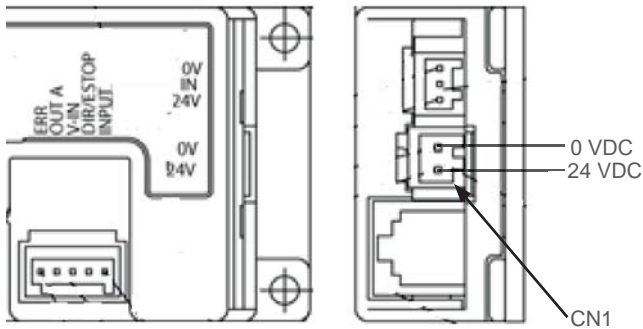

- 24 V dc switch-mode power supply, which can accept an overcurrent of 150% for 3 to 5 s, is recommended.
- The +24 V dc circuit is protected by a 7A fuse.
- Connector WAGO 734-102, wire-cross section 1,5mm² max (AWG : 20~14)

! Provide a power supply that is sufficiently powerful in function of the type and number of motorized rollers to be powered.

The stabilized power supplies 24V shall be sized according to the number of motorized rollers that shall work. It is possible to link some group of motorized rollers to the power supplies. These groups being link together thanks to communication cable.

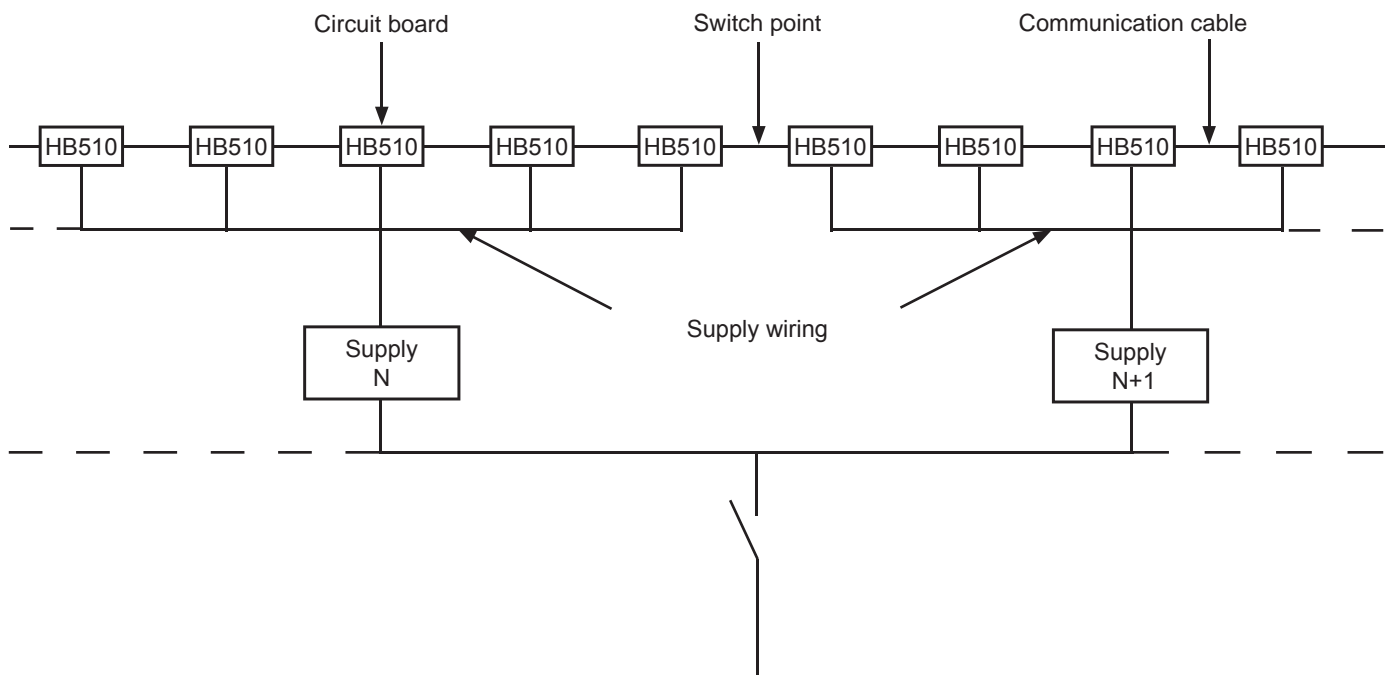

! It is mandatory to link the 0V in between the power supplies. They shall be controlled simultaneously to avoid creating problem in transition point.

! Make sure that the power supply is OFF before plugging / unplugging the motor connector CN6.

! Do not use the 24 V dc circuit-breaker or the 24 V dc power-supply circuit-breaker to turn the motorized roller "On/Off". You must use Terminal 5 of the CN2 connector.

CONNECTOR CN2 - INPUTS / OUTPUTS (I/O)

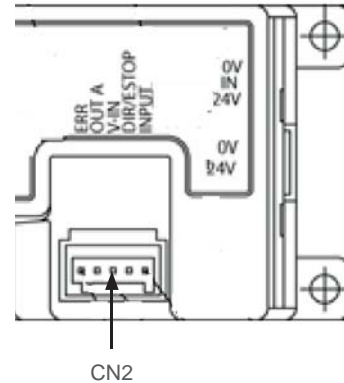
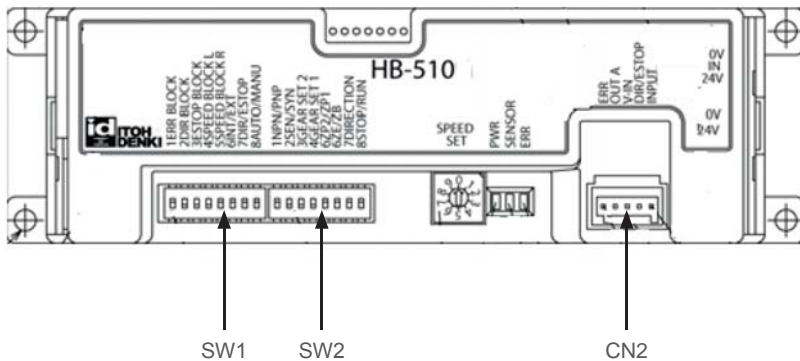

- Connector WAGO 734-105, Wire cross-section 0,08~0,5mm² max (AWG : 28~20)

CN2			Related Parameters	
Terminal	Description		SW1	SW2
1-ERR	Error signal 24V output, 25mA maxi to adjust in terms of the automatism with a resistor not supplied (open collector) The error signal is sent when everything is normal.			
2-OUT A	Synchronisation This output allows to synchronize the start-up and stop of several motors on a same zone. (wire this output to the Run/Stop terminal of the circuit boards of the other motorized rollers). 24V output, 25mA maxi (to adjust in terms of the automatism with a resistor not supplied).			
	Sensor signal This output allows to recover the sensor status. 24V output, 25mA maxi (to adjust in terms of the automatism with a resistor not supplied).			
3-V-IN	Speed variation Speed variation by analogic external voltage 0-10V (input current 4,5mA to 10V)			
4-DIR E-STOP	Transfer direction Reverse load transfer direction and logic of defined zones (input current 1mA to 24V)			
	Emergency stop Allow an emergency stop of all the defined zones with input on terminal 4 of connector CN2 of one circuit board of the zone (input current 1mA to 24V)			
5-INPUT	Start / Forced Stop Forced start to evacuate load on the last zone. (24V, 1mA)			
	Forced stop to keep a load on the zone even if the downstream zone is empty. (24V, 1mA)			

⚠ Prioritized : E-Stop > Initialisation > Start / Stop forced

⚠ The function E-Stop allows to stop together all the motorized rollers managed by the block but not allows to turn off the 24VDC supply.

Output error signal, synchronisation and sensor signal 24VDC - 25mA max to add according to the automation with a resistor (not supplied) to add.

PNP (HB510P / HB510BP)

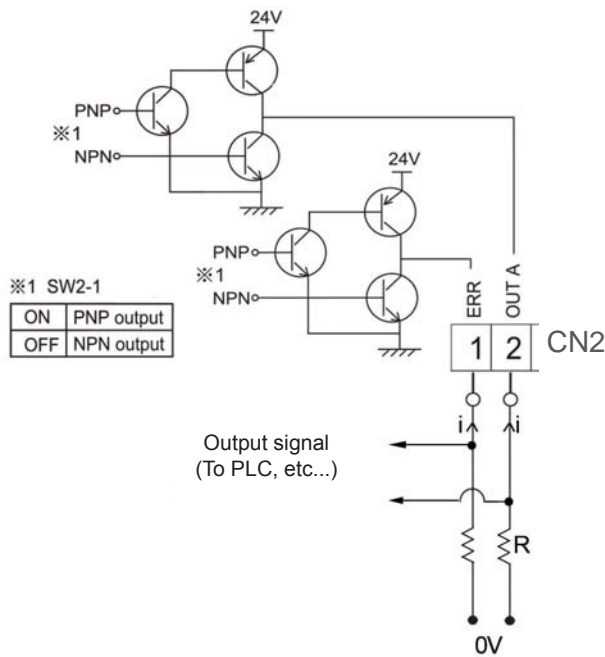

NPN (HB510N / HB510BN)

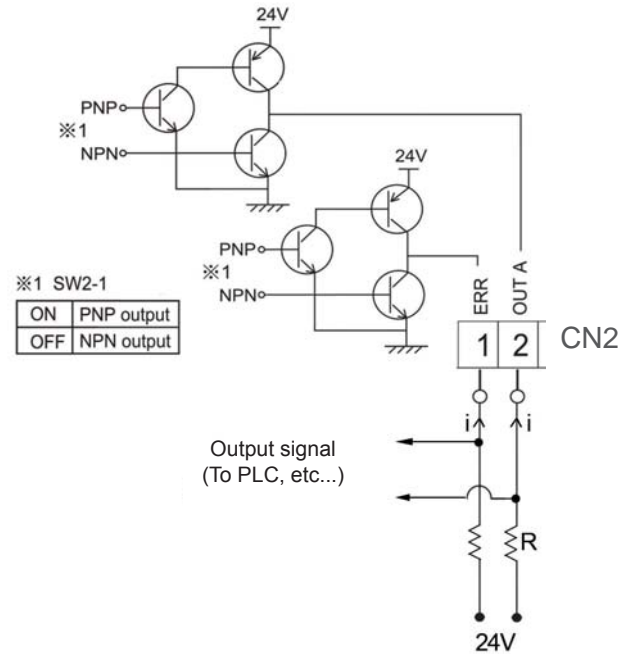

We must adjust the resistance «R» so that the current «i» does not exceed 25mA.

$$25\text{mA} \geq \frac{24}{R} \quad R \geq \frac{24}{0,025}$$

$$R \geq 960\Omega$$

In the event of a current ≥ 25 mA, there is a risk of damaging the transistor.

CONNECTOR CN3 - SENSOR

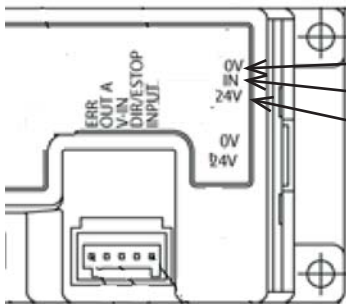

⚠ Use a sensor type NO (open contact), 24V, 35mA max

0V
Sensor state
24VDC

• Connector WAGO 733-103, wire-cross section 0,08 - 0,5 mm² max (AWG : 28~20)

CONNECTORS CN4 AND CN5 - COMMUNICATION CABLE

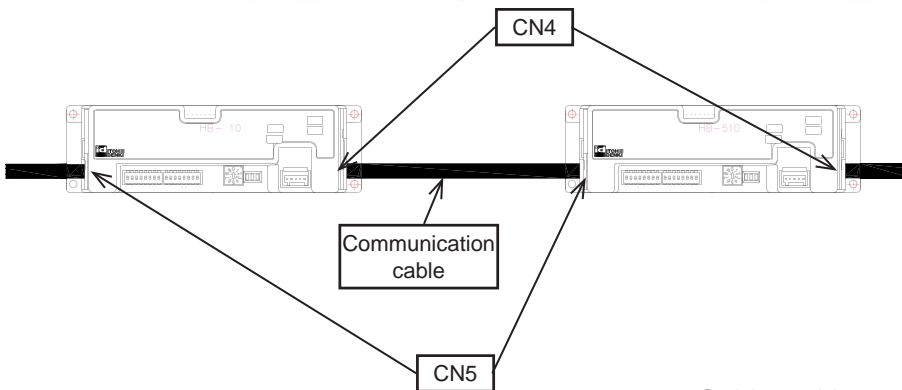
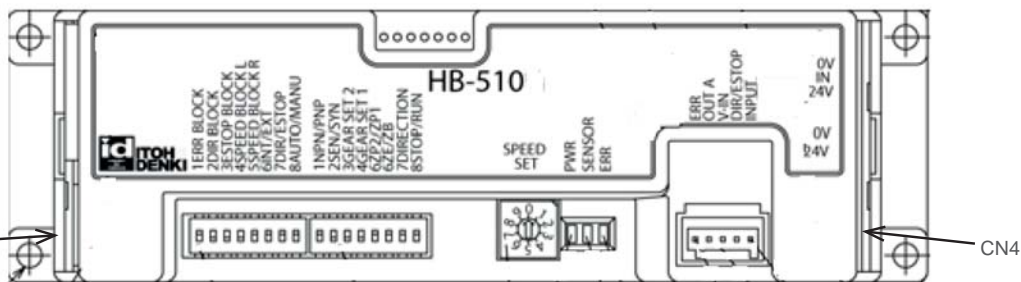

• Cables with connector RJ45.

⚠ Always connect the connector CN4 circuit board to the CN5 connector of another circuit board.

Cable lengths (mm)	Reference
1000	CCOM-HB5X-1000
2000	CCOM-HB5X-2000
3000	CCOM-HB5X-3000

CONNECTOR CN6 - MOTOR

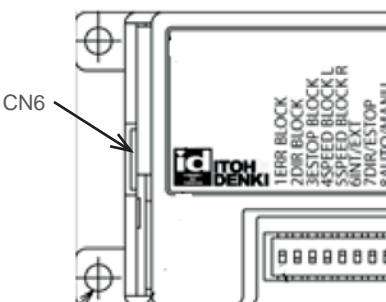

⚠ Do not disconnect the motor connector during operating.

Motorized roller	Connector	Circuit board
PM500FE PM605FE PM500FS PM500FP	JST#S9B-XH-A 9 pins	HB510 N / P
PM500FE-B PM605FE-B PM500FS-B	JST#S10B-XH-A 10 pins	HB510 BN / BP

LED1, LED2 AND LED3

Color, state and speed flash allow to see the following indications :

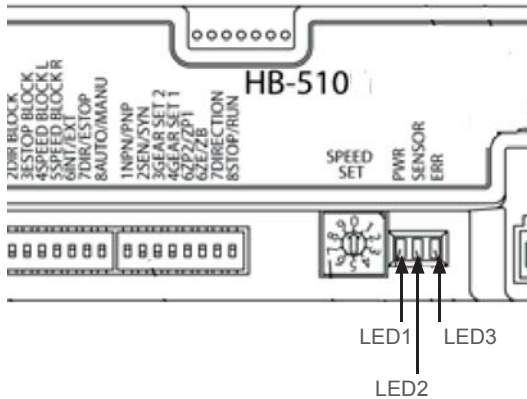











LED1		Green	Supply Motorized roller state
LED2		Orange	Sensor state
LED3		Red	Error signal

LED 1			
	Led off	Led on	1 flash per seconde
	OFF	ON	Motorize roller operate

LED 2			
	Led off	Led on	1 flash per seconde
	- OFF - No load behind the sensor	ON	Motorize roller operate

LED 3				
	Led off	Led on	1 flash per seconde	6 flashes per seconde
	OFF	- Thermal release - Motorized roller not connected	- Motorized roller blocked more than 4s - Fuse out of service - Insufficient power voltage	Overload

LED1	LED2	LED 3	Output signal		Cause	Motorized roller condition	Solutions
			PNP	NPN			
			24V	0V	-	-	-
			No signal		Thermal default	Stopped	In case of manual restart (SW1-8 ON), 1 minute after drops below the thermal trip threshold, signal Run → Stop → Run
			24V	0V	The motorized roller is jammed for more than 4 seconds.	Power reduce	Remove the overload cause.
			No signal		Connector CN6 disconnected.	No power	Remove power and properly connect the motorized roller.
			No signal		Jam / blocking load	Stopped	Remove the jam / blocking cause and secure the supply voltage above 18VDC or replace the circuit board if it's the fuse.
			No signal		Input voltage insufficiente or fuse	Stopped	
			24V	0V	Overload	-	-

- In case of power failure, the LED 3 lights up briefly to signal a fault in the power supply.
- In case of motorized roller blocking, it gives jolts to release the load. If the problem persists beyond 4s, the motorized roller stopped and the circuit board will fault.
- To restart the motorized roller, must give an order to the terminal 5 (Start / Stop) or 4 (Direction) of connector CN2 after remove the fault cause (release of blocked load, cooling the thermal protection...)
- After a power failure, on restart, the motorized rollers operate a certain period to allow the possible load detection (between two sensors), and management zones of the circuit board is active. (see chapter «Initialisation»)
- In the case where the LED 1 is flashing slowly, and LED 2 flashes quickly, this indicates a current limiting (overload), but the circuit board does not go in default.
- When the current absorbed reaches 4A*, the Led 3 flashing 6 time per second to signal the overload state.

*Except starting current peak.

■ DIP-SWITCH SW1 - SELECTION AND CONFIGURATION OF THE FUNCTIONS

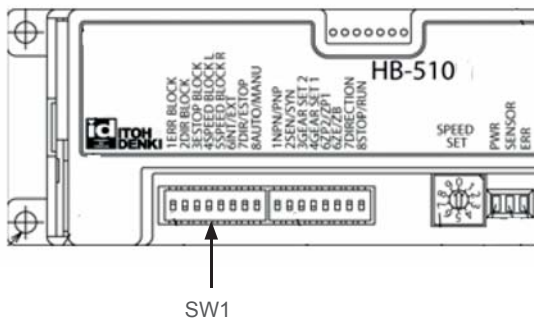

The positioning of the SW1 dip-switches are used to set the following functions :

Dip switches	Position	Function	Position	Function	Initial setting
1	ON 	Transmission of the error signal to the circuit board connected to the right on the CN4 connector	OFF 	No transmission of the error signal	ON
2	ON 	Direction transmission	OFF 	No direction transmission to the right circuit board	ON
3	ON 	Emergency stop signal transmission to the circuit board connected to the right on the connector CN4	OFF 	No transmission of the emergency stop signal	ON
4	ON 	External voltage speed variation transmission to the circuit board connected to the left on CN5	OFF 	No external voltage speed variation transmission to the circuit board connected to the left on CN5	ON
5	ON 	External voltage speed variation transmission to the circuit board connected to the right on CN4	OFF 	No external voltage speed variation transmission to the circuit board connected to the right on CN4	ON
6	ON 	Speed selection by external analogic voltage	OFF 	Speed selection by SW3	ON
7	ON 	Selection of emergency stop (E-stop)	OFF 	Selection of direction (DIR)	ON
8	ON 	Manual restart after thermal fault	OFF 	Automatic restart after thermal fault	ON

DIP-SWITCH SW2 - SELECTION AND CONFIGURATION OF THE FUNCTIONS

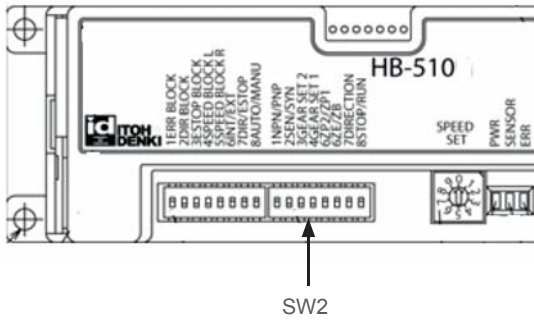

The positioning of the SW2 dip-switches are used to set the following functions :

Dip switches	Position	Function	Position	Function	Initial setting HB510-P	Initial setting HB510-N
1	ON	Selection PNP output signal	OFF	Selection NPN output signal	ON	OFF
2	ON	Selection output signal for synchronisation	OFF	Selection sensor status on output signal	ON	ON
3 / 4	ON OFF 3 4	Motorized roller speed : code 15 / 25	OFF ON 3 4	Motorized roller speed : code 55	OFF ON 3 4	OFF ON 3 4
5	ON	Mode ZPA : train mode	OFF	Mode ZPA : singulated	ON	ON
6	ON	Selection intermediate zone	OFF	Selection end zone	ON	ON
7	ON	Selection motorized roller serie PM500FE or PM605FE	OFF	Selection motorized roller serie PM500FS or PM500FP	ON	ON
8	ON	Selection forced start	OFF	Selection forced stop	ON	ON

SW3 - SELECTION FIXED SPEED

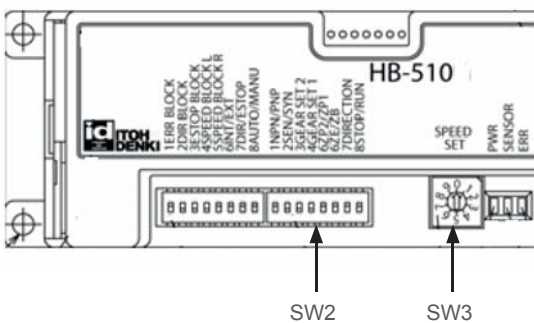

Load (min)	Nom	Selection Internal Sélecteur SW3	Ext. une te
61.7	49.4	9	9.5±0.1
56.6	49.4	8	8.5±0.2
51.4	49.4	7	7.5±0.2
46.3	46.3	6	6.5±0.2
41.1	41.1	5	5.5±0.2
36.0	36.0	4	4.5±0.2
30.9	30.9	3	3.5±0.2
	25.7	2	
	20.6	1	

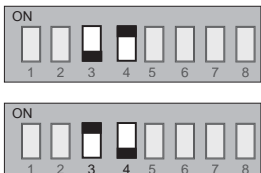

Speed code 55

Speed code 15 / 25

Position SW2-3 and 4 according to motorized roller speed code, then SW3 to adjust speed.



Right position SW2-3 and 4 as shown. Not position on ON-ON or OFF-OFF.

5. TIMERS

■ RUN HOLDING TIMER

This is the start-up motorized roller timer of zone «N-1» relative to the state «OFF» of the cell of the zone «N-1». It allows motorized roller of zone «N-1» to operate during the time it takes to evacuate the load on zone «N-1».

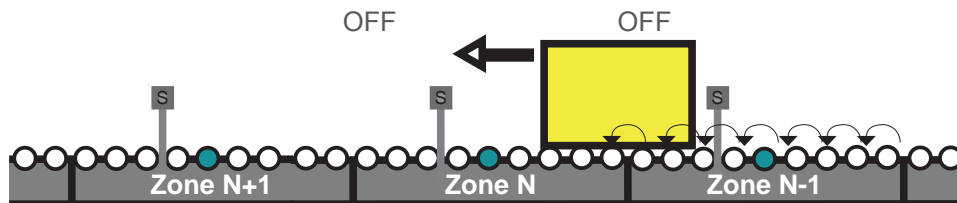

The time of timer depend of SW2 dip-switches 3 and 4 setting (see table below).

■ SENSOR TIMER

This is the start-up motorized roller timer of zone «N» relative to the state «OFF» of the cell of the zone «N-1». It allows motorized roller of zone «N» to operate during the time it takes to receipt load to the cell of the zone «N».

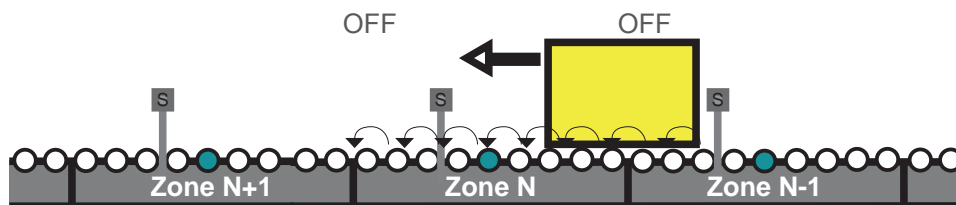

Timer depending on speed code

Speed code	SW2		Timer (s)
	3	4	
15 / 25 / 55*	ON 	OFF 	4 ~ 14
55	OFF 	ON 	1 ~ 4
Not position	OFF 	OFF 	0,3 ~ 1,2
	ON 	ON 	Start-up motorized roller except cells of zone and the downstream, which are «ON»

! Position correctly SW2-3 and 4. Do not position on ON-ON or OFF-OFF.
 Motorized roller stop if sensor S1 detects nothing after the time defined by SW2.
 The delay time is defined for the time it takes to move load over a distance of about 1 m.

*55 : In case of failure of the delay time.

JAM TIMER

Detection jam / blocking loads

When a load is on the zone (state sensor is ON) and the next zone is free, the circuit board will start-up the motorized roller. If the sensor state doesn't change (stay ON) for a defined period (Time depending on speed code) so it means there is a Jam : motorized roller stop and an error signal is sent.

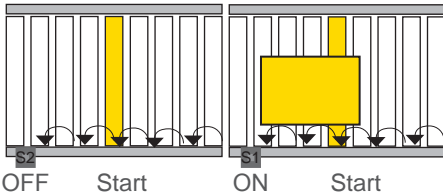

In combination with «Sensor timer» and «Run holding timer», it allows HB510 to detect the jam / blocking at the sensor or between the sensors.

Jam / blocking between the sensors

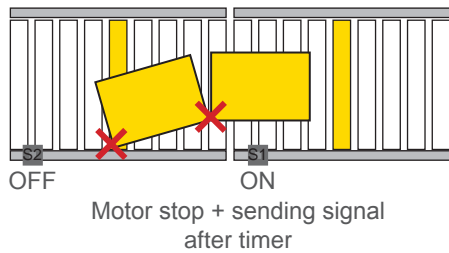
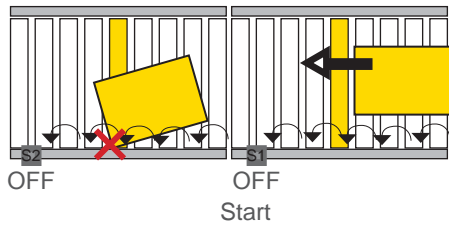

Jam / blocking at the sensor

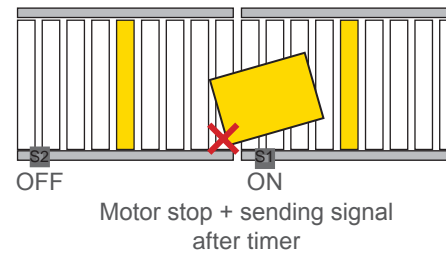
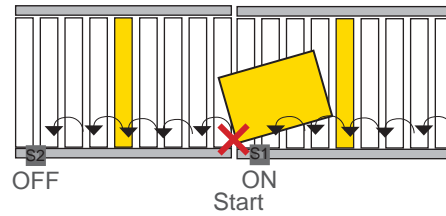

Timer depending on speed code

Speed code	SW2		Timer (s)
	3	4	
15 / 25 / 55*	ON <input type="checkbox"/>	OFF <input type="checkbox"/>	7,5 ~ 27
55	OFF <input type="checkbox"/>	ON <input type="checkbox"/>	1 ~ 8
Not position	OFF <input type="checkbox"/>	OFF <input type="checkbox"/>	0,6 ~ 2,2
	ON <input type="checkbox"/>	ON <input type="checkbox"/>	Start-up motorized roller except cells of zone and the downstream, which are «ON»

*In case of failure of the delay time.

Position correctly SW2-3 and 4. Do not position on ON-ON or OFF-OFF. The delay time is defined for the time it takes to move load over a distance of about 2 m.

INITIALIZATION

When powering, or after unblocking emergency stop, loads which are located between the areas of sensors are conveyed at the minimum speed until the next zone. Loads which are in front of sensor don't move.

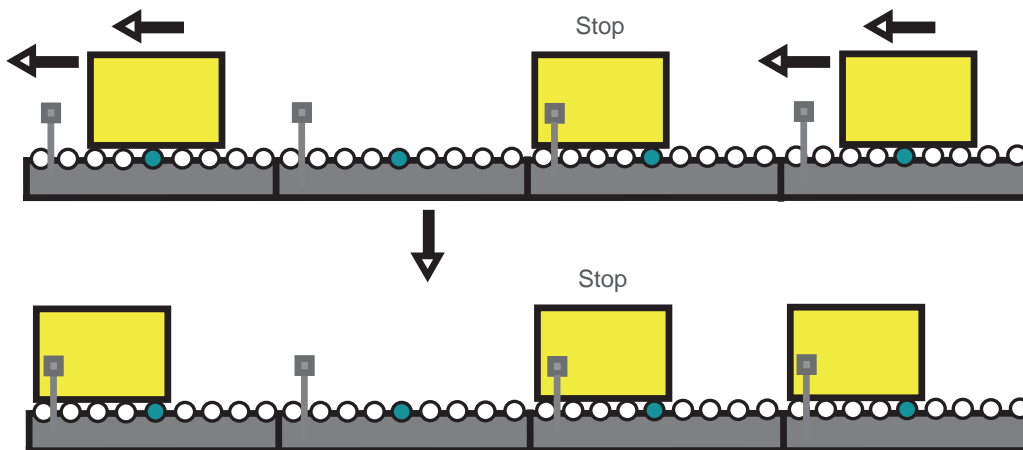

When the initialization phase is complete, circuit board management zones activates.

Speed code	SW2		Initialization time(s)
	3	4	
15 / 25 / 55*	ON 	OFF 	14
55	OFF 	ON 	4

Initialization function is est priority over the order «Start / Stop forced» but not priority to «E-Stop».

6. FUNCTIONS AND SETTINGS

TRANSFER MODES

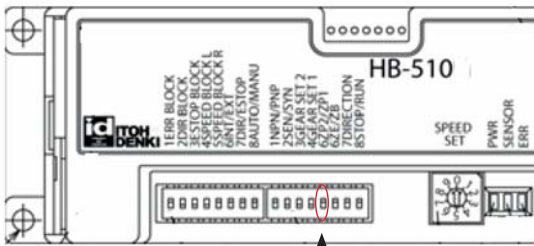

ON



Load transfer train mode

OFF



Load transfer singulated mode

SW2

A - Load transfer singulated mode

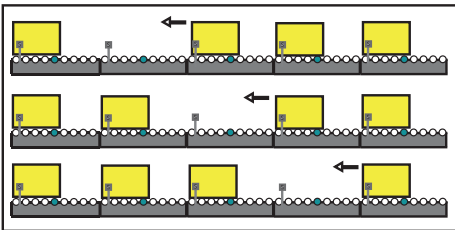

This transfer mode allows to move load step by step : when the downstream zone sensor detects that it's free, it send signal which active upstream zone to move load one by one, zone by zone.

B - Load transfer train mode

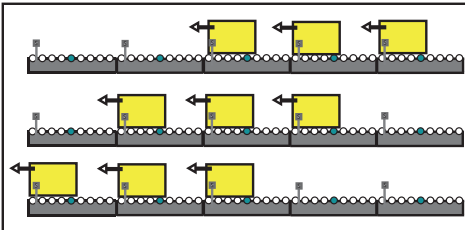

This transfer mode allows to move load together : when the downstream zone sensor detects that it's free, it send signal which active together all the upstream zones to move load together.

C - Short and long load transfer

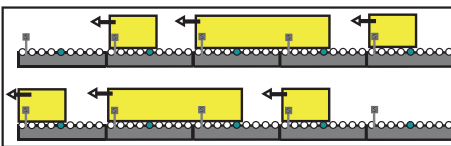

It allows conveying loads which are longer than one zone. Indeed, thanks to a patented management system call «Flexible management», if the load take several zones by its length, these zones are recognized like one zone. It allow a continuous conveyor of different length of load without change length zone. Flexible zone management is possible when all the zones operate in train mode.

D - Spacing load / Discard management

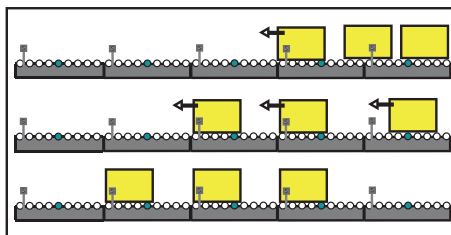

Thanks to the two transfer modes explained above, we can manage discards between load in order to ensure proper distance. Indeed, if the conveyor is in train mode, configuring just one zone in singulated mode, upstream load wait that the load which is in the singulated mode zone leave this zone.



This function is not compatible with «flexible zone management» and it does not allow to separate loads which are touching eachothers.

SYNCHRONIZATION

Depending on of conveyor's length, weight and dimensions of load to be conveyed, it's possible to place several motorized rollers in a zone. In this case, a synchronized mode is used to manage together all the motorized rollers of this zone.

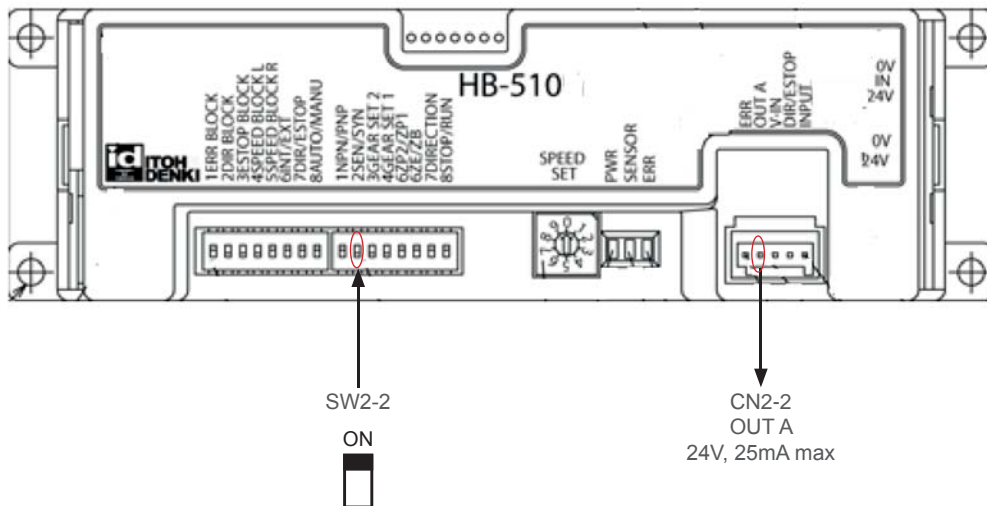

Output CN2-2 Out A and SW2-2 in position «ON» allows to synchronize start and stop of several motors on a same zone.

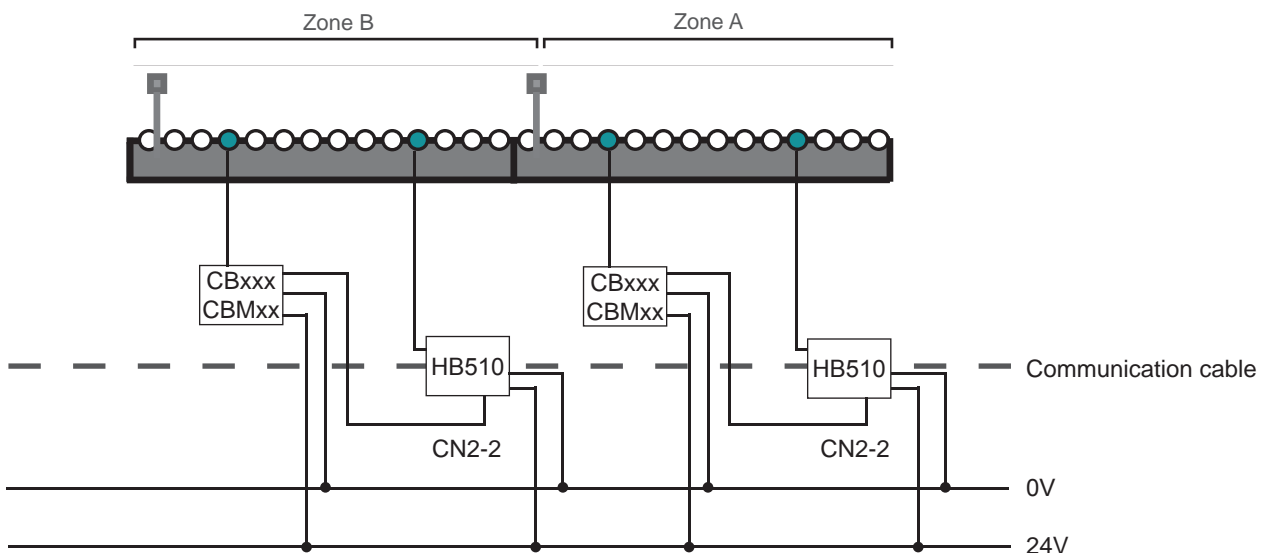

Connect terminal 2 of connector CN2 of circuit board HB510 to terminal Start/Stop of connector of circuit board CBM105xxx or CB016xxx of the others motorized rollers.

0V of circuit board HB510 must imperatively be connected to terminal 0V of CBM-105 or CB016.

FUNCTION «FORCED START»

It's possible to forced start of zone with SW2-8 in position ON and to sent signal on terminal CN2-5. This function will be useful for the beginning or the end of zone.

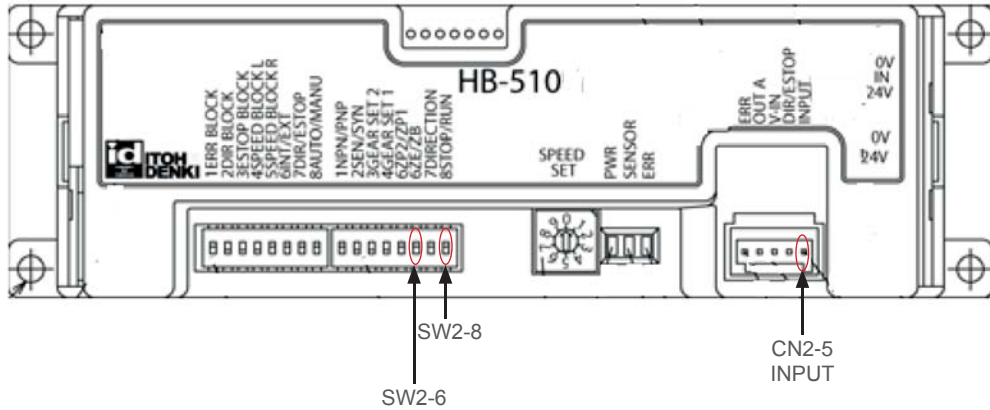

First zone control

All the zones must be configured in intermediate zones, SW2-6 on «ON».

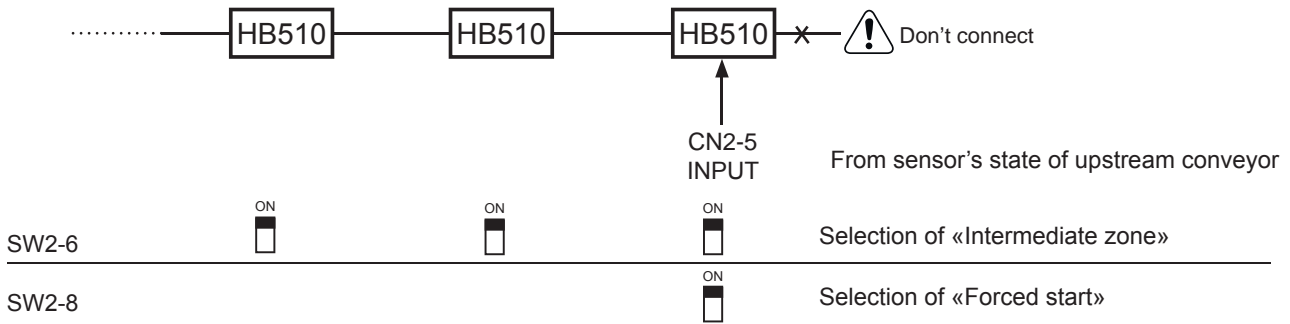
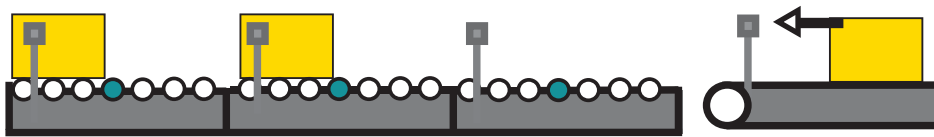

The reception of load of upstream conveyor on the first zone will be performed with signal «Forced start» on «INPUT» of terminal CN2 of circuit board HB510. For this, don't connect communication cable to terminal CN4. When the load is detected by sensor, and when the downstream zone is busy, the load stop even if the «Forced start» is active (Zone management overrides). The upstream conveyor have to be manage to move load when the first zone is free and stop when it is busy.

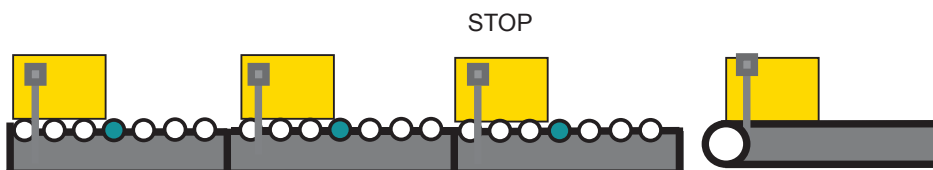

End of zone control

All the zones must be configured in intermediate zones, SW2-6 on «ON», except the last which has to be configured in end zone, SW2-6 on «OFF».

To evacuate the last zone, a forced start signal shall be given to the circuit board of the last zone.

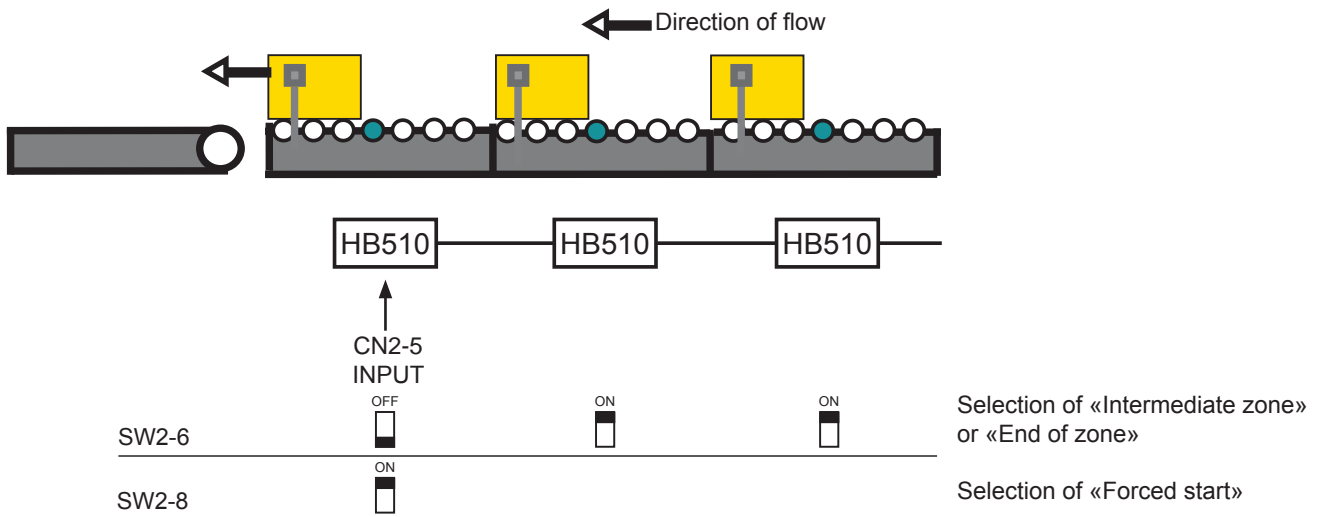

The load move while the signal «Forced start» on terminal CN2-5 is activated and stop when it disable. To evacuate several loads, the forced start signal on terminal CN2-5 shall remain, the time that the loads are evacuated.

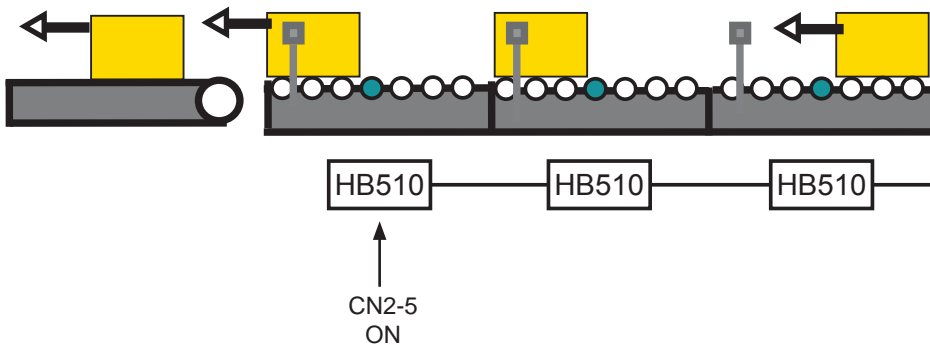

if the signal «Forced start» is disable and the last zone is empty, the load move and stop automatically when the sensor detect it.

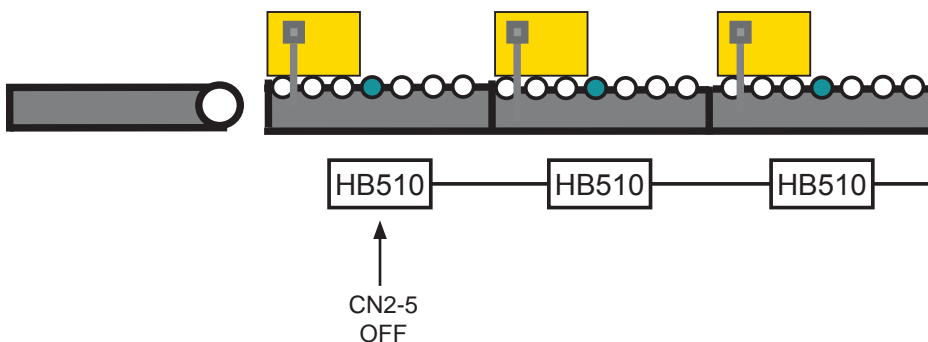

■ FUNCTION «FORCED STOP»

It's possible to force a stop on a zone to put SW2-8 on position OFF and by sending a signal on terminal CN2-5. The load will move to sensor of zone B (for example), then stop. ZPA function will restart once the signal of CN2-5 is removed.

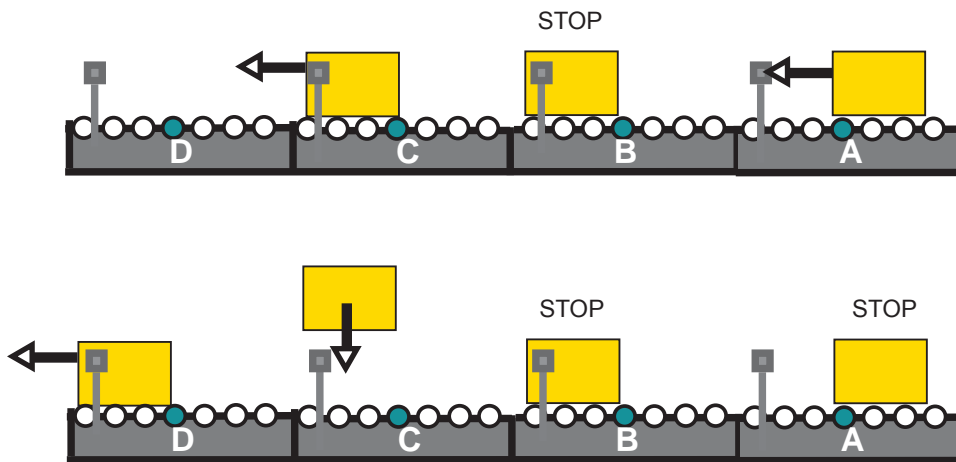
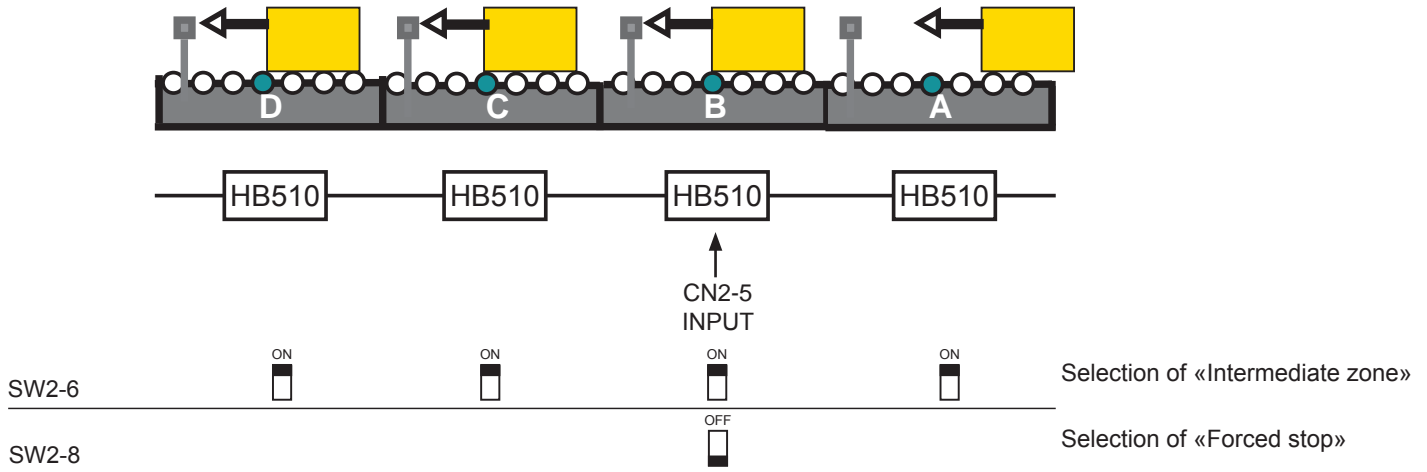

This function allows :

- inserting a load by creating empty zones downstream of the stopped zone
- generate spaces between the loads

7. BLOCK CREATION

It's possible to create block of zones which are connected by communication cable to perform controls or specific management with SW1 like :

- Direction of flow management
- Speed variation with voltage 0-10V
- Error signal transmission
- Emergency stop

Depending on desired controls, you can create a block controlling signals transmission by communication cable of HB510 with dip-switches SW1-1 to SW1-5.

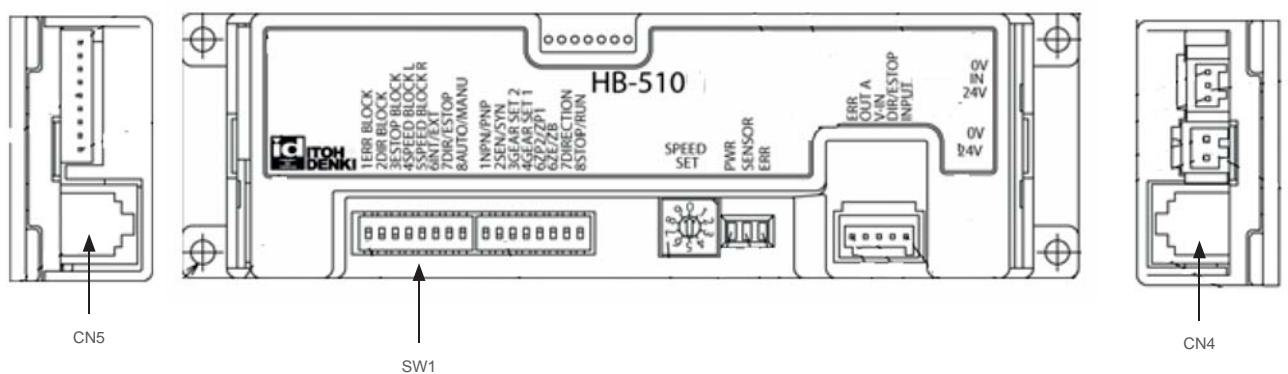

- **HB510** — Transmission activated
- **HB510** ✗ — Transmission right deactivated
- ✗ **HB510** — Transmission left deactivated

		Initial setting	ON	OFF
Error signal	SW1-1	ON		
Direction (flow direction)	SW1-2	ON		— HB510 ✗ —
Emergency stop	SW1-3	ON	— HB510 —	
Speed variation	SW1-4	ON		✗ HB510 —
	SW1-5	ON		— HB510 ✗ —

SETTINGS LOGIC FLOW DIRECTION RELATIVE TO LOAD MOVE DIRECTION

Before proceeding to other settings, it is imperative to first set the flow direction.

Direction of loads move = Direction of circuit board logic flow

Logic flow by circuit board HB510 is determine for a load transfer right to left relative to the circuit board in front view.

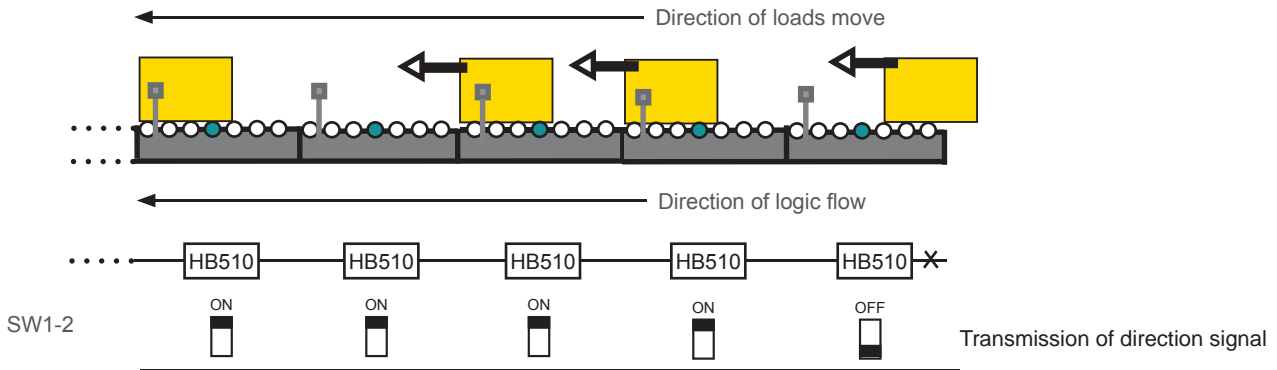

Direction of loads move ≠ Direction of circuit board logic flow

If transfer load direction requested is opposite to flow logic direction, it's possible to inverse it. For this, put the dip-switch SW1-2 on ON for all circuit boards of the conveyor in order to transmit signal to the others and send signal of inversion of flow direction on terminal 4 of CN2. Motorized rollers will turn in the opposite direction and logic flow will be inverted. (30 circuit board max).

It's possible to send signal of flow inversion on any circuit board provided that SW1-7 is on OFF. If direction of rotation of motorized rollers is inverted compared to flow direction, it have to setting rotation direction of motorized roller. (see next paragraph).

! You must redefine last zone and repositione sensors in order to they are at the end of each zone.

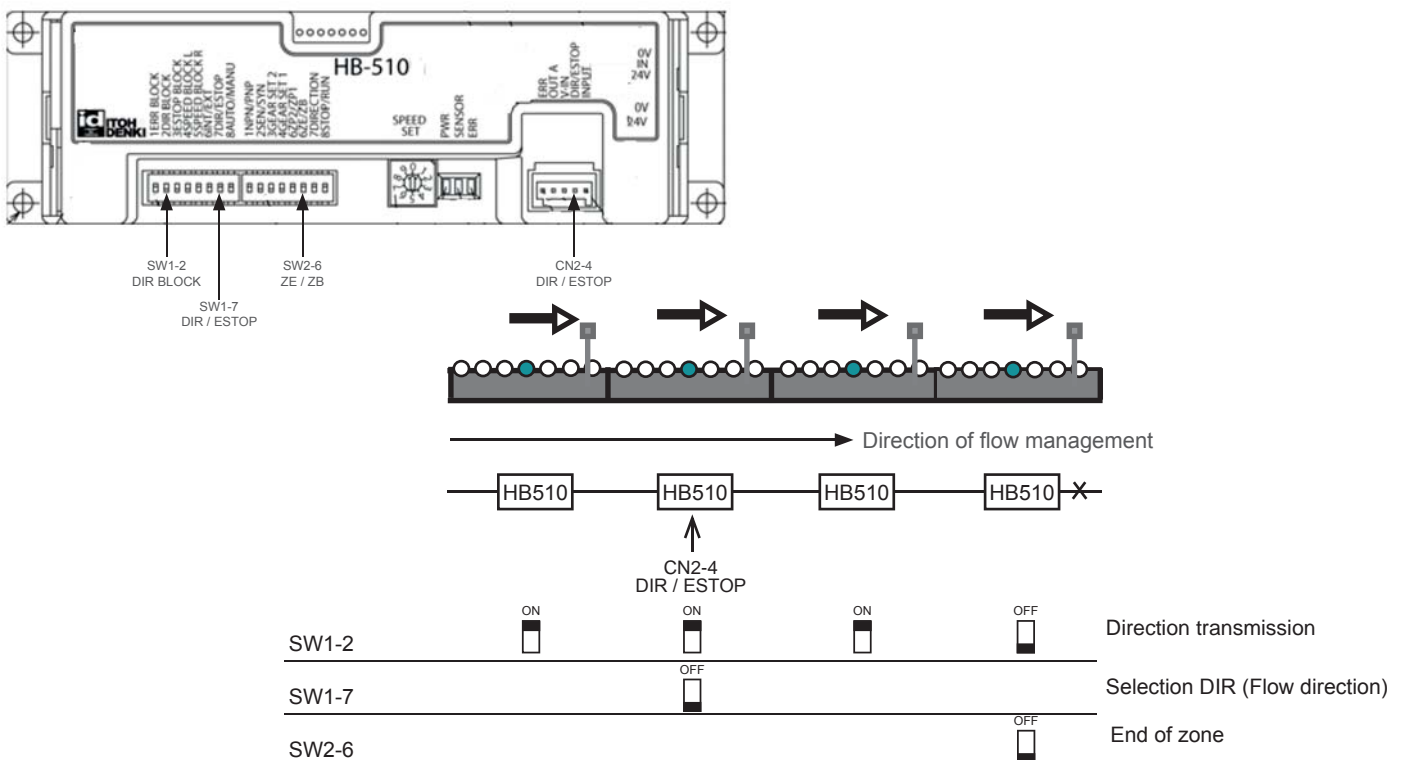

■ SETTINGS MOTORIZED ROLLERS ROTATION DIRECTION RELATIVE TO LOGIC FLOW DIRECTION

Direction of motorized roller rotation depend on :

- Motorized roller series (Type FE or FS/FP)
- Location of circuit board (HB510) and motorized rollers on conveyor

This setting is performed with dip-switch SW2-7

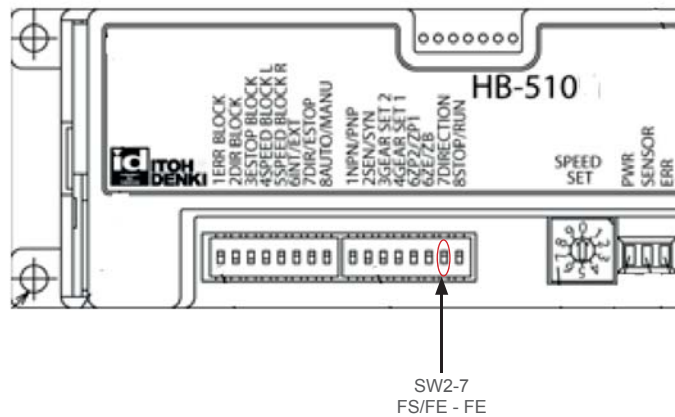

• Straight line - Circuit board and motor are on the same side

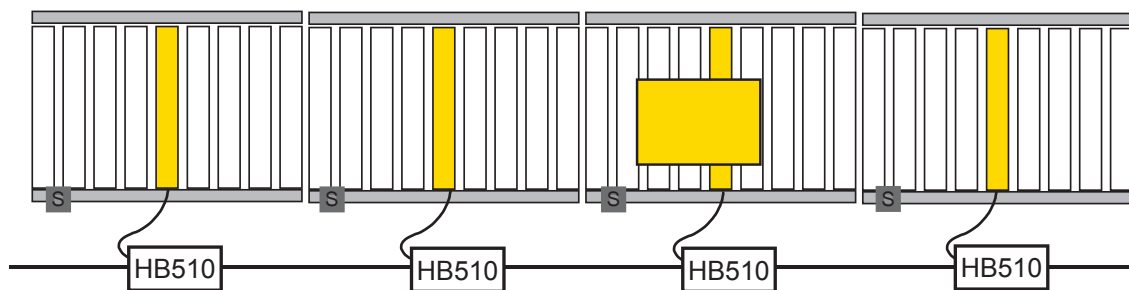

SW2-7	PM500FE - 605FE	PM500FS/FP
ON 		
OFF 		

Front view of the circuit board HB510

Don't change the direction of rotation during the motorized roller turn. First, stop the motor and then, change the direction of rotation.

• Straight line - Circuit board opposite to the motorized roller

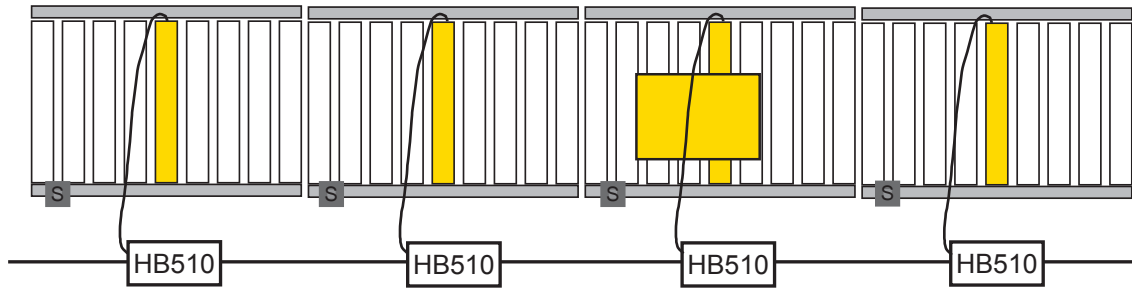

	SW2-7	PM500FE - 605FE	PM500FS/FP
ON			
OFF			

Front view of the circuit board HB510

For this configuration, it is necessary to use an extension motor cable.

Cable extension length	Reference
1,2m	ACE-CBM-B1200
2,7m	ACE-CBM-B2700

• Curve - All circuit board are on the same side

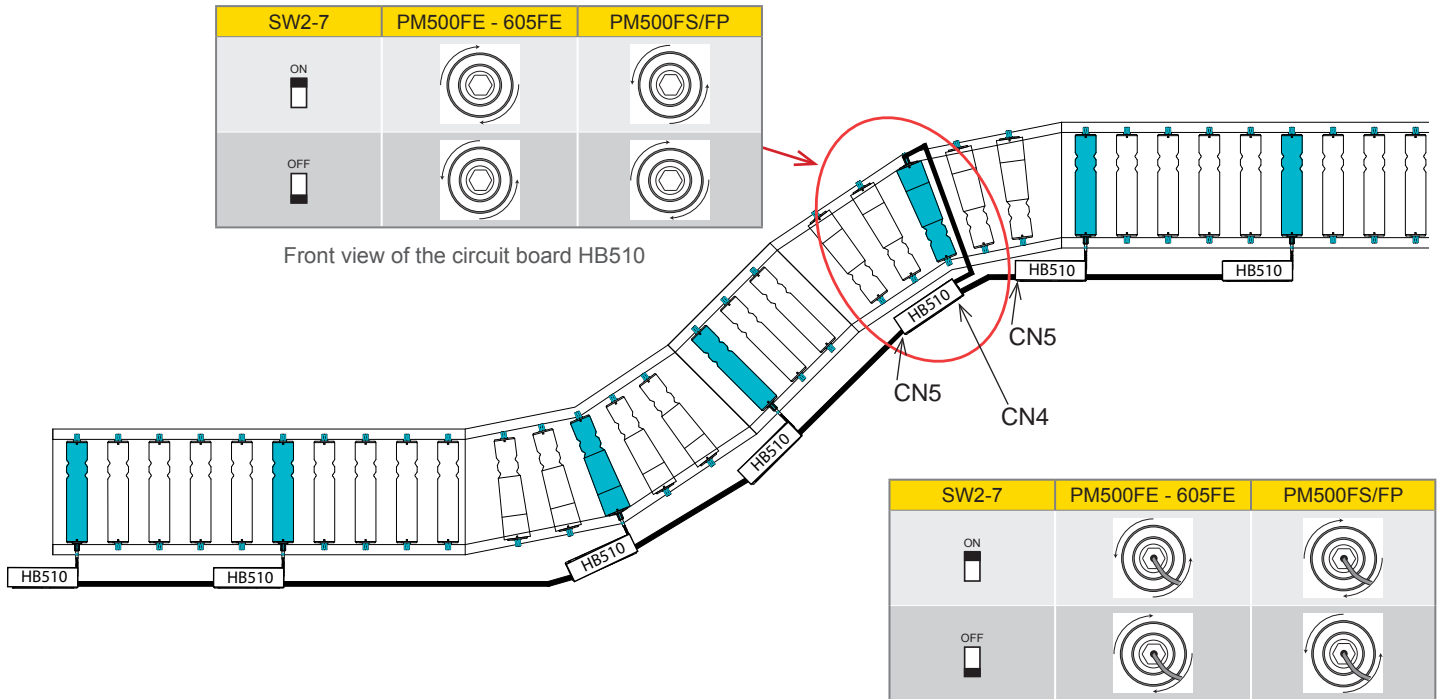

• Curve - Circuit board are not all on the same side

The sides of connectors CN4 and CN5 are inverted compared to the others circuit board HB510 which are on the opposite side of the conveyor.

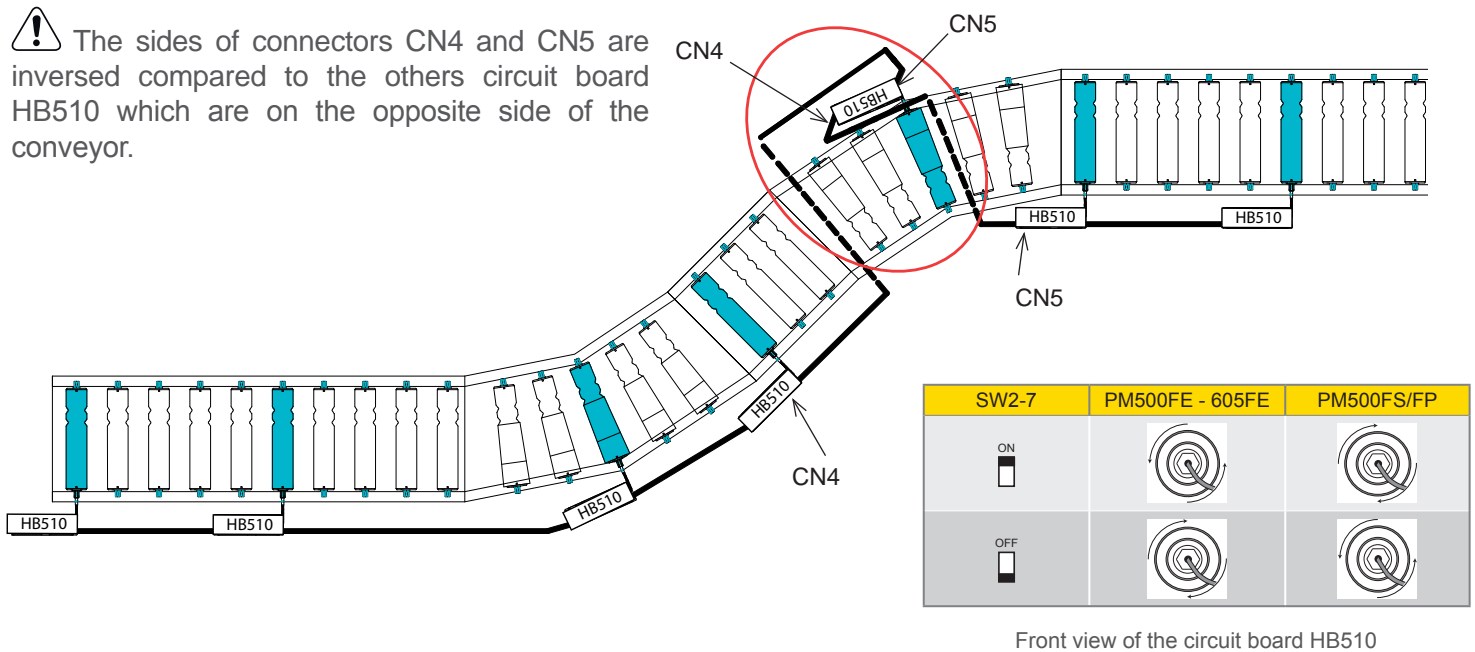

SPEED VARIATION

To adapt to the speed of conveyor which are upstream or downstream, to the cadence of the machine and the regulation of cadence, HB510 circuit board have a function of individual internal speed variation with integrated potentiometer or by external control while maintaining rated torque of the motorized roller.

It can also vary speed of up to 30 zones together, by sending an analogic voltage to only one circuit board «pilot». This «pilot» circuit board transfer information to the other circuit boards connected by communication cable. To increase the number of zones to manage above 30 zones, we just send an analogic voltage to another circuit board of the next group of zones. We can also combine the management of grouped and individual speed to create zones with specific speed.

SETTING INTERNAL SPEED BY ROTARY SWITCH SW3

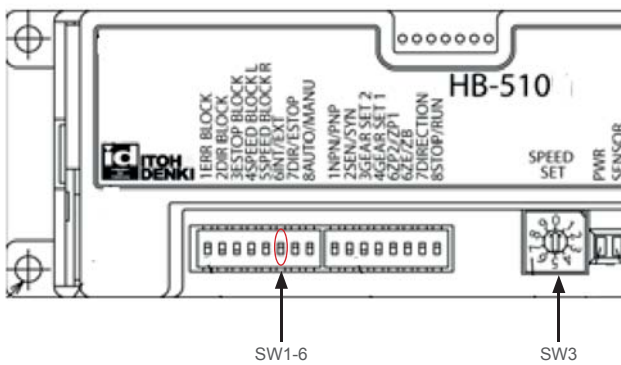

- SW1-4 OFF
- SW1-5 OFF } Transmission inactive
- SW1-6 OFF Setting internal speed
(⚠️ Priority over external speed control)
- SW3 See characteristics of each motorized roller

Example for PM500FE series speed code 15

No load	Nominal	Internal SW3
17,4	13,9	9
15,9	13,9	8
14,5	13,9	7
13,0	13,0	6
11,6	11,6	5
10,1	10,1	4
8,7	8,7	3
7,2	7,2	2
5,8	5,8	1
4,3	4,3	0

⚠️ The set speed with SW3 can't be transmitted to the others circuit boards.

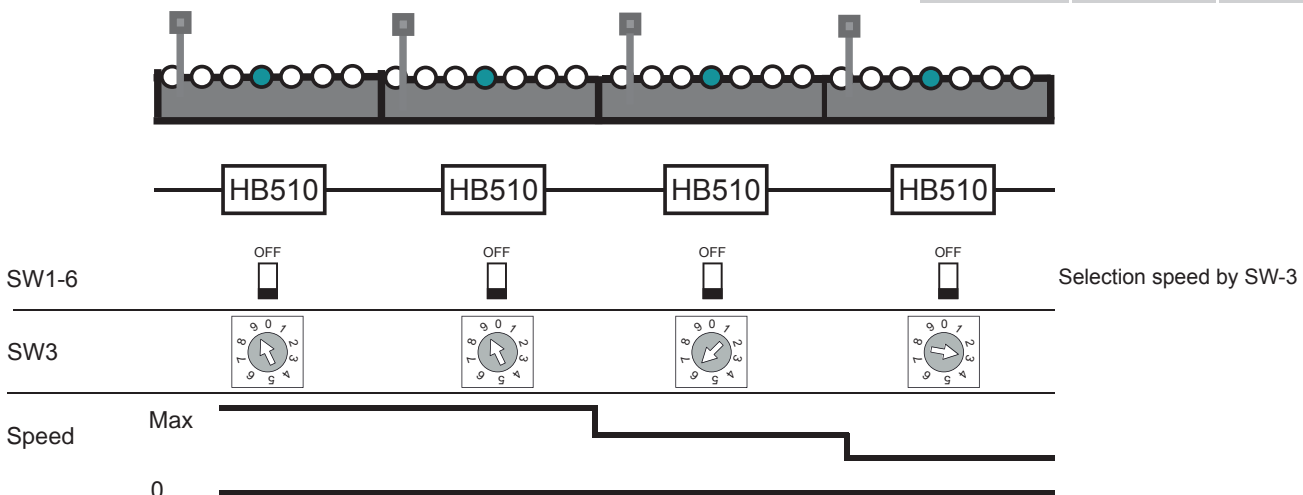

EXTERNAL SPEED CONTROL BY ANALOGIC VOLTAGE 0-10V

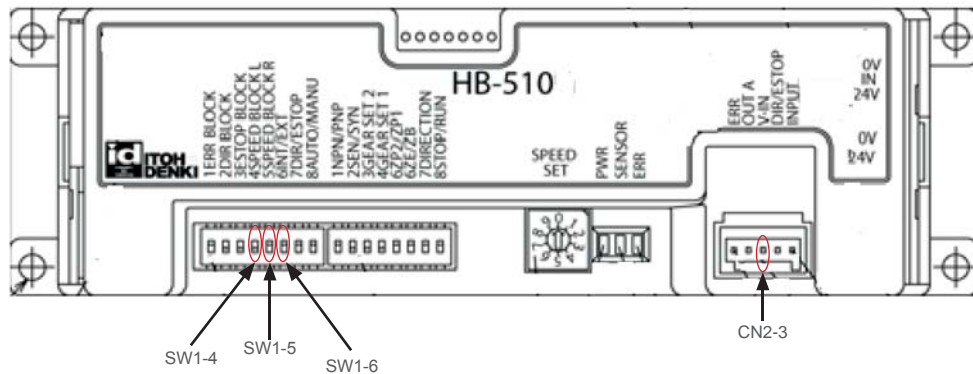

Selection direction of transmission

It can also be vary speed of 30 circuit board maximum starting from circuit board which have analogic voltage 0-10V («pilot» circuit board).

To increase the number of circuit boards to be vary the speed, just add pilot circuit boards.

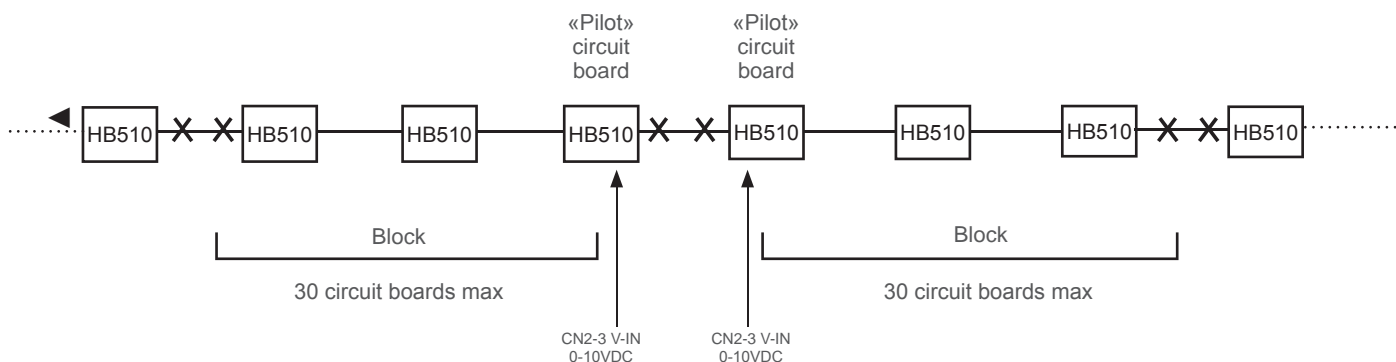

SW1-4	<input type="checkbox"/> ON	<input type="checkbox"/> OFF	<input type="checkbox"/> ON	<input type="checkbox"/> ON	<input type="checkbox"/> OFF	<input type="checkbox"/> ON	<input type="checkbox"/> ON	<input type="checkbox"/> OFF
SW1-5	<input type="checkbox"/> OFF	<input type="checkbox"/> ON	<input type="checkbox"/> ON	<input type="checkbox"/> OFF	<input type="checkbox"/> ON	<input type="checkbox"/> ON	<input type="checkbox"/> OFF	<input type="checkbox"/> ON
SW1-6	<input type="checkbox"/> ON	<input type="checkbox"/> ON	<input type="checkbox"/> ON	<input type="checkbox"/> ON	<input type="checkbox"/> ON	<input type="checkbox"/> ON	<input type="checkbox"/> ON	<input type="checkbox"/> ON

Application of analogic voltage 0-10V on terminal 3 of CN2

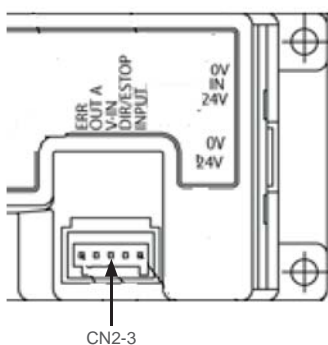

See characteristics of each motorized roller

No load	Nominal	Internal SW3	External by voltage
17,4	13,9	9	9,5+/-0,2
15,9	13,9	8	8,5+/-0,2
14,5	13,9	7	7,5+/-0,2
13,0	13,0	6	6,5+/-0,2
11,6	11,6	5	5,5+/-0,2
10,1	10,1	4	4,5+/-0,2
8,7	8,7	3	3,5+/-0,2
7,2	7,2	2	2,5+/-0,2
5,8	5,8	1	1,5+/-0,2
4,3	4,3	0	0,5+/-0,2

⚠ Connect all the 0V of the external analogic alimentation 0-10VDC of speed variation together and to the 0V of the alimentation of HB510.

⚠ Do not exceed 10VDC for varying the speed by external analogic voltage.

INTERNAL AND EXTERNAL SPEED VARIATION

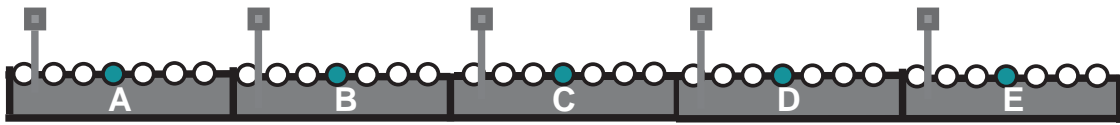

CN2-3
V-IN
0-10 VDC

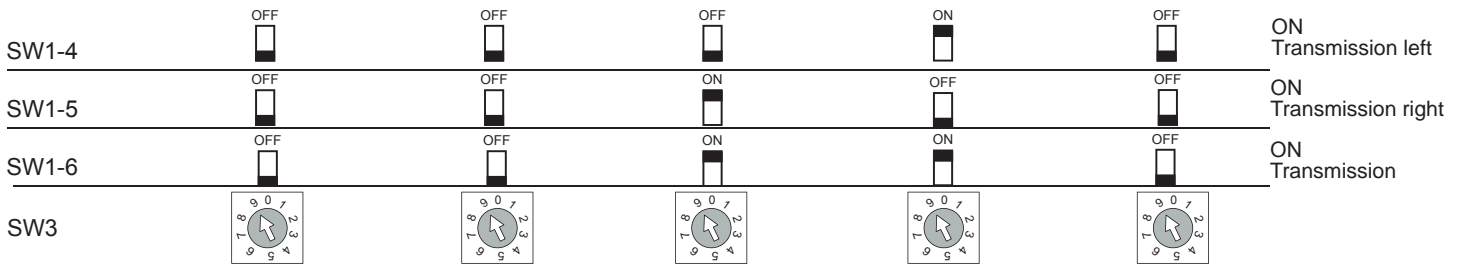

	A	B	C	D	E
Zone(s) of variation	A	B	C and D		E
Injection DC 0-10V	NA	NA	C or D		NA

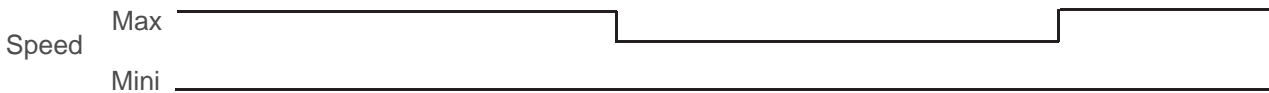

ERROR SIGNAL RECOVERY

In case of anomaly, red LED give signal (see chapter «Error signal») but it's possible to retrieve this signal on a PLC to locate the zone or the bloc of zones in fault from a monitoring station. We can manage it individually or grouping circuit boards HB510 (in block).

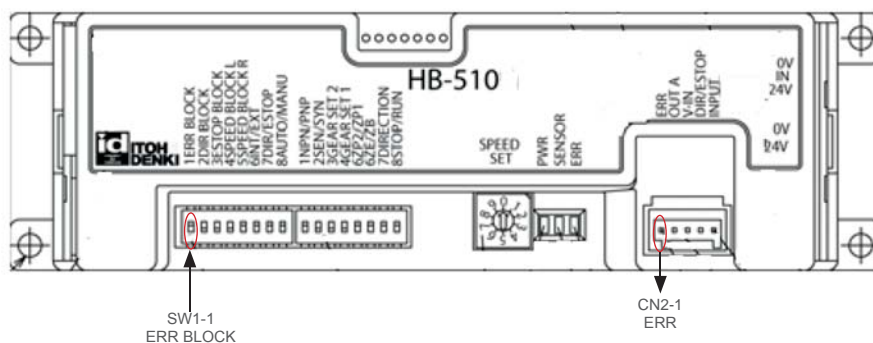

INDIVIDUAL MANAGEMENT

Putting SW1-1 on position OFF for all the circuit boards, it's possible retrieve individually the signal on terminal 1 of connector CN2.

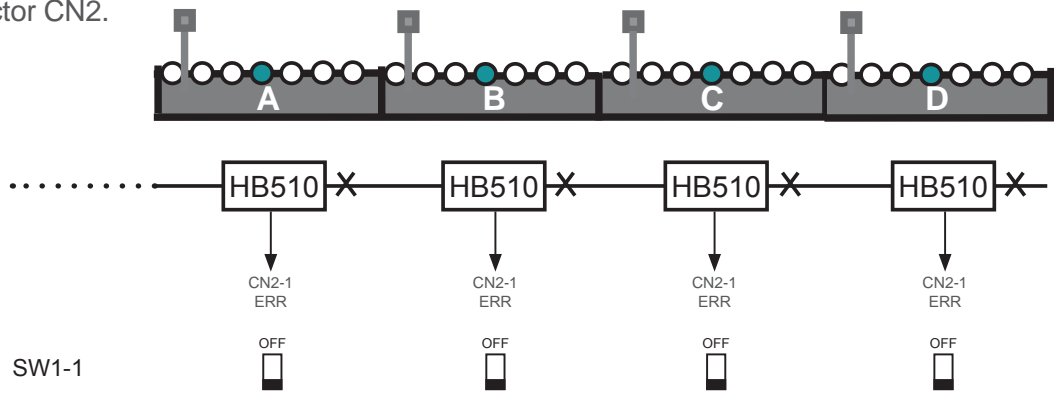

BLOCK MANAGEMENT

To create a block, put dip-switch SW1-1 on ON for all the circuit boards of the block except the circuit board at the right end (front view of the circuit board).

If a fault appear in this block, red LED of the circuit board of the zone in fault light and, in the same time, an error signal will be sent on terminal 1 of CN2 of all the circuit boards of the block.

To locate this signal, just connect terminal 1 of CN2 of one of the circuit boards of the block to a PLC, for example. The downstream zones of the zone in fault continue to function normally and the upstream zones accumulate to the zone in fault.

In case of management of error by block, it's not possible to specify the location in fault but the block where the zone in fault is.

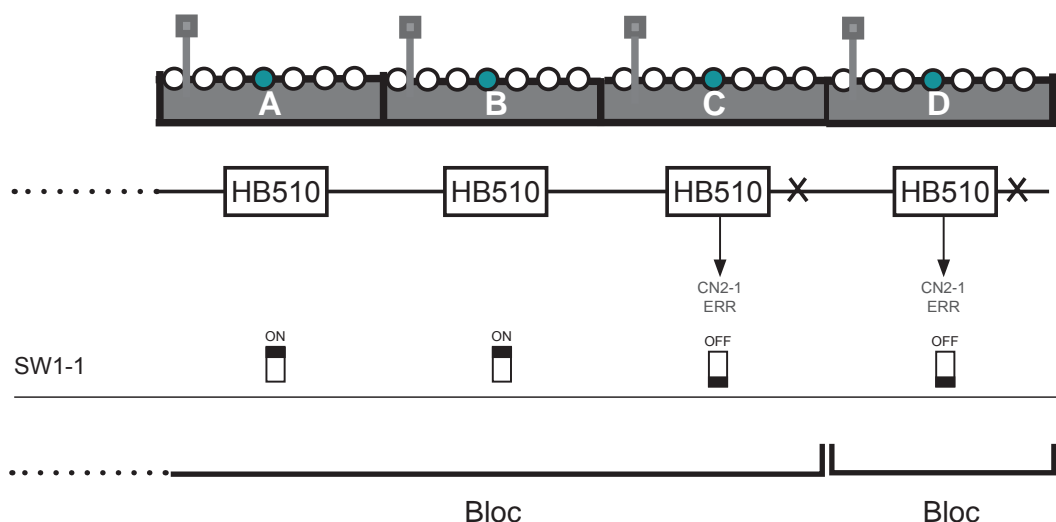

Zone of emission of error signal	Recovery error signal by terminal 1 of CN2
A	A, B or C
B	
C	
D	D

IMPLEMENTATION OF SEVERAL FUNCTIONS IN THE SAME BLOCK

With dip-switches SW1 / SW2 and input / output signal of CN2, it's possible to apply several functions in a block delimited by SW1.

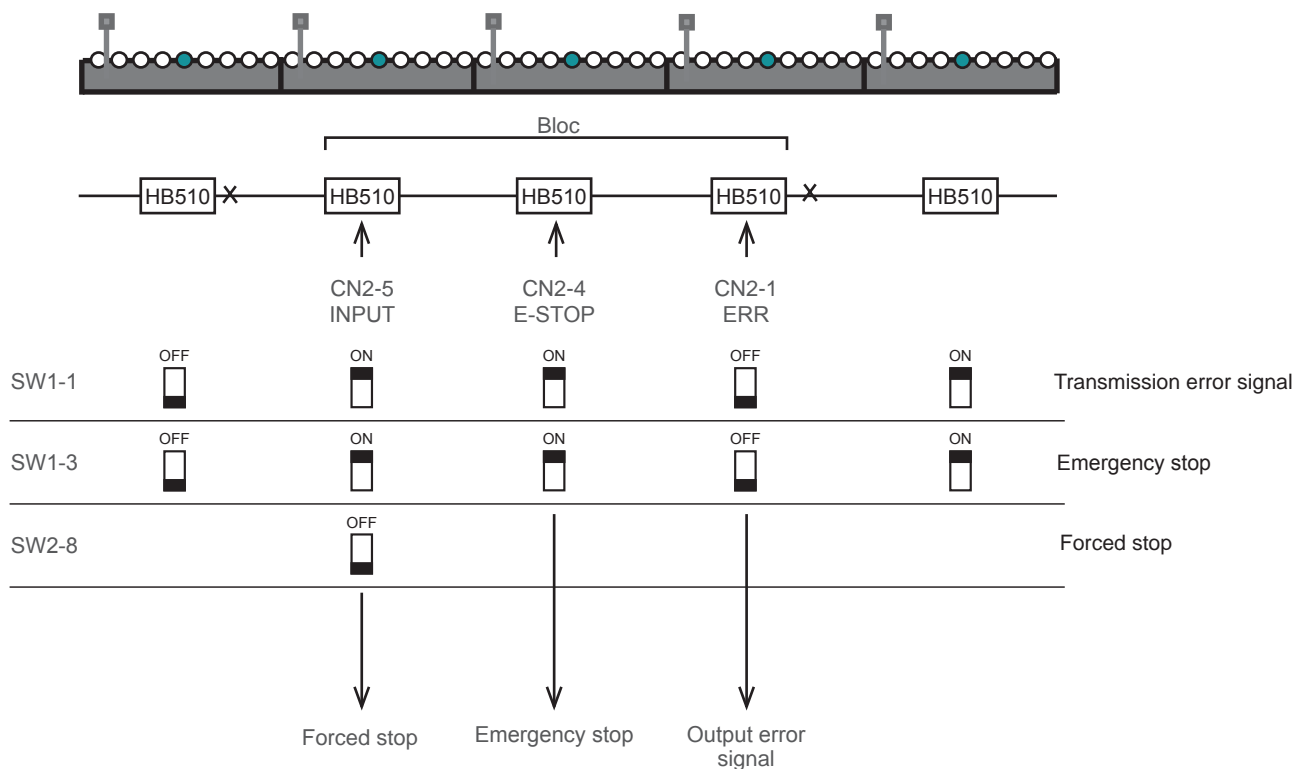

RECOMMENDED SETTING ORDER

Order	Control / Setting	Topics	Pages
1	Setting flow direction of loads	<ul style="list-style-type: none"> Setting logic flow direction relative to load move direction. Setting motorized roller direction relative to logic flow direction 	30 31-33
2	Control end of zone	<ul style="list-style-type: none"> Control end of zone 	27
3	Timers setting	<ul style="list-style-type: none"> Timers 	21-22
4	ZPA mode setting	<ul style="list-style-type: none"> Transfer mode 	24
5	Speed setting	<ul style="list-style-type: none"> Speed variation 	34-36
6	Control first zone	<ul style="list-style-type: none"> Control first zone 	26
7	Control forced stop	<ul style="list-style-type: none"> Function «Forced stop» 	28
8	Control input / output	<ul style="list-style-type: none"> Connector CN2 	14-15
9	Synchronization other motorized rollers	<ul style="list-style-type: none"> Synchronization 	25
10	Blocks setting	<ul style="list-style-type: none"> Block creation 	29-39

▶ APPENDIX 1

INCORPORATION DECLARATION

IN ACCORDANCE WITH THE EC MACHINERY DIRECTIVE 2006/42/EC, ANNEX II B

The manufacturer :

ITOH DENKI CO., Ltd
1146-2 Asazuma-Cho, Kasai, Hyogo 679-0180 Japan

Distributed in Europe by::

ITOH DENKI Europe SAS
490 avenue des Jourdiés - ZAE les Jourdiés - BP 323
74807 St Pierre en Faucigny Cedex - France

hereby declares that the product series:

CIRCUIT BOARD HB510

is an incomplete machine as defined in the EC Machinery Directive and therefore does not fully meet the requirements of this Directive. Service entry is prohibited until the whole machine/system in which it is incorporated is declared to be in compliance with the EC Machinery Directive.

The health and safety requirements of Annex I have been applied. The special technical documents in accordance with Annex VII have been drawn up (and, if appropriate, submitted to the competent authorities).

Person authorized to compile the technical documentation :

Toshiyuki TACHIBANA
ITOH DENKI CO., Ltd
1146-2 Asazuma-Cho, Kasai, Hyogo 679-0180 Japan

EC Directives applied:

- **Machinery Directive 2006/42/CE**
- **European EMC Directive CEM 2004/108/CE**
- **European RoHS Directive RoHS 2011/65/EU**

Saint Pierre en Faucigny, 24 february 2015

K. TAMURA, Managing Director

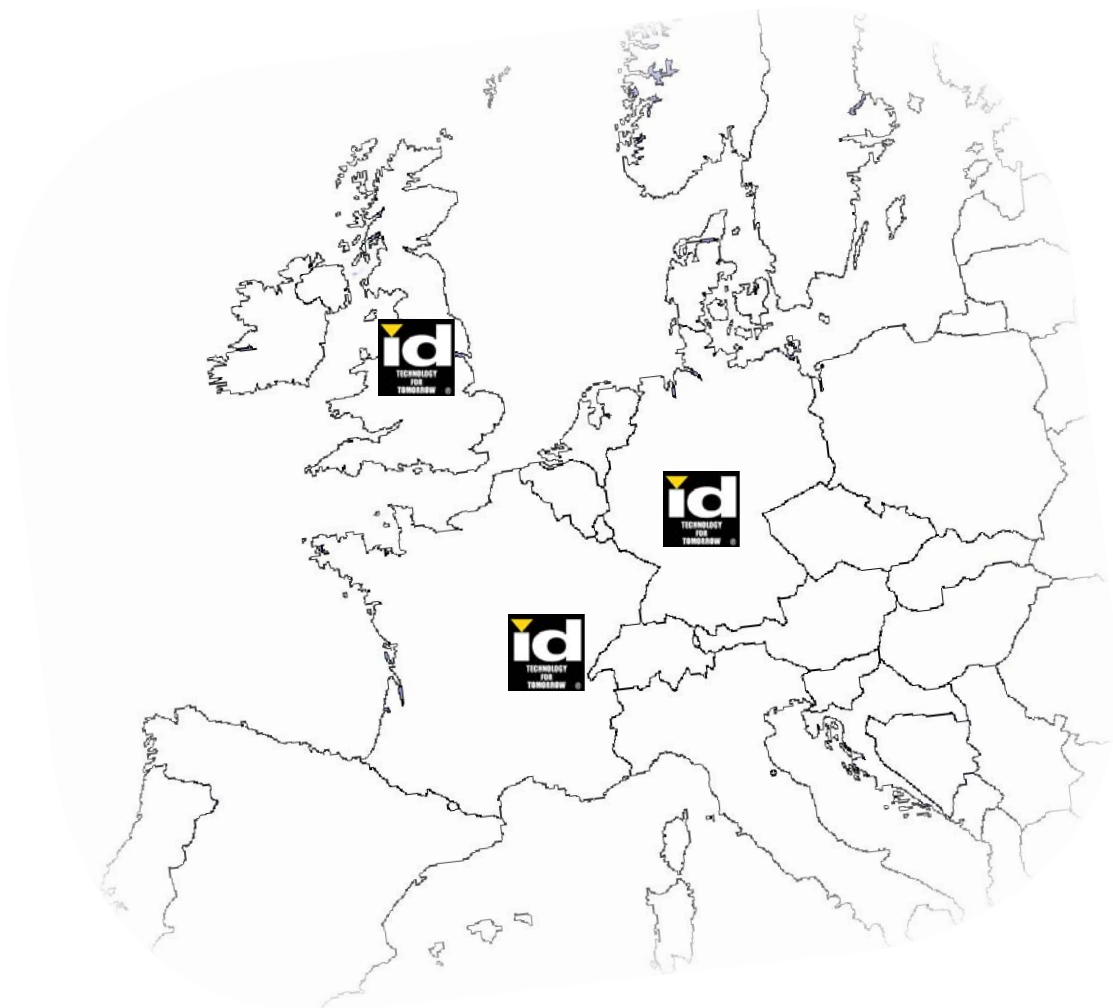

ITOH DENKI EUROPE S.A.S.

490 Av. des Jourdiés
Z.A.E. les Jourdiés
74800 St Pierre en Faucigny - France
Tél. : +33 (0)4 50 03 09 99
Fax : +33 (0)4 50 03 07 60
E-mail : info@itoh-denki.com

SUCCURSALE ITOH DENKI ANGLETERRE

Suite 1 Trinity Space Centre
Waldorf Way
Wakefield WF2 8DH - UK
Tél : +44 (0)1924 366 539
Fax : +33 (0)4 50 03 07 60
E-mail : info@itoh-denki.com

SUCCURSALE ITOH DENKI ALLEMAGNE

Neumeyerstrabe 48
90411 NÜRNBERG - Deutschland
Tel : +49 911 25 26 - 200
Fax : +49 911 25 26 - 201
E-mail : info@itoh-denki.de