

# PM500FE-B SERIE

TECHNICAL DOCUMENTATION



## SUMMARY

1 - Presentation of the PowerMoller product range	Page 5
2 - Presentation of the series	Page 6
General characteristics	
Structure and description	
Applications	
Characteristics depending on circuit board	
3 - Transfer capacity	Page 11
Ribbed belt drive	
4 - Presentation of the different fixing options	Page 13
5 - Dimensional characteristics	Page 15
Grooved tube - Hexagonal shaft with spring on free end	
Grooved tube - M8 threaded shaft with screw on free end	
Roller with pulley for ribbed belt - Hexagonal shaft with spring on free end	
Roller with pulley for ribbed belt- M8 threaded shaft with screw on free end	
Roller with pulley for round belt - Hexagonal shaft with spring on free end	
Roller with pulley for round belt - M8 threaded shaft with screw on free end	
Roller without drive - Hexagonal shaft with spring on free end	
Roller without drive - M8 threaded shaft with screw on free end	
6 - Dimensional characteristics - miscellaneous	Page 23
PVC sleeve	
Coated in natural rubber, nitrile rubber and polyurethane	
Crowned machining	
7 - Belt conveyor application	Page 24
Condition of use and recommendation	
Structure	
Transfer capacity	
Dimensional characteristics and weight	
Tube specification	
8 - Mounting on the frames	Page 30
Mounting plate for plain 11.1 mm hexagonal shaft - Flat on top	
Mounting plate for plain 11.1 mm hexagonal shaft - Angle on top	
Mounting plate for threaded hexagonal shaft - Flat on top	
Mounting plate for threaded hexagonal shaft - Angle on top	
M8 threaded fixed shaft	
9 - Wiring	Page 32
With CB016BP circuit board	
With HB510BP circuit board	
10 - Accessories	Page 33
<i>Ribbed belts</i>	
<i>Extension cables</i>	
<i>Rounded belts</i>	
<i>24 VDC power supply</i>	
<i>24 VDC distribution connector</i>	
11 - Product identification	Page 35
<i>Round label</i>	
<i>Square label</i>	
12 - Quotation/order	Page 36
Annex 1 : Incorporation declaration	Page 38



# 1 - PRESENTATION OF THE POWER MOLLER® PRODUCT RANGE

## POWER MOLLER®

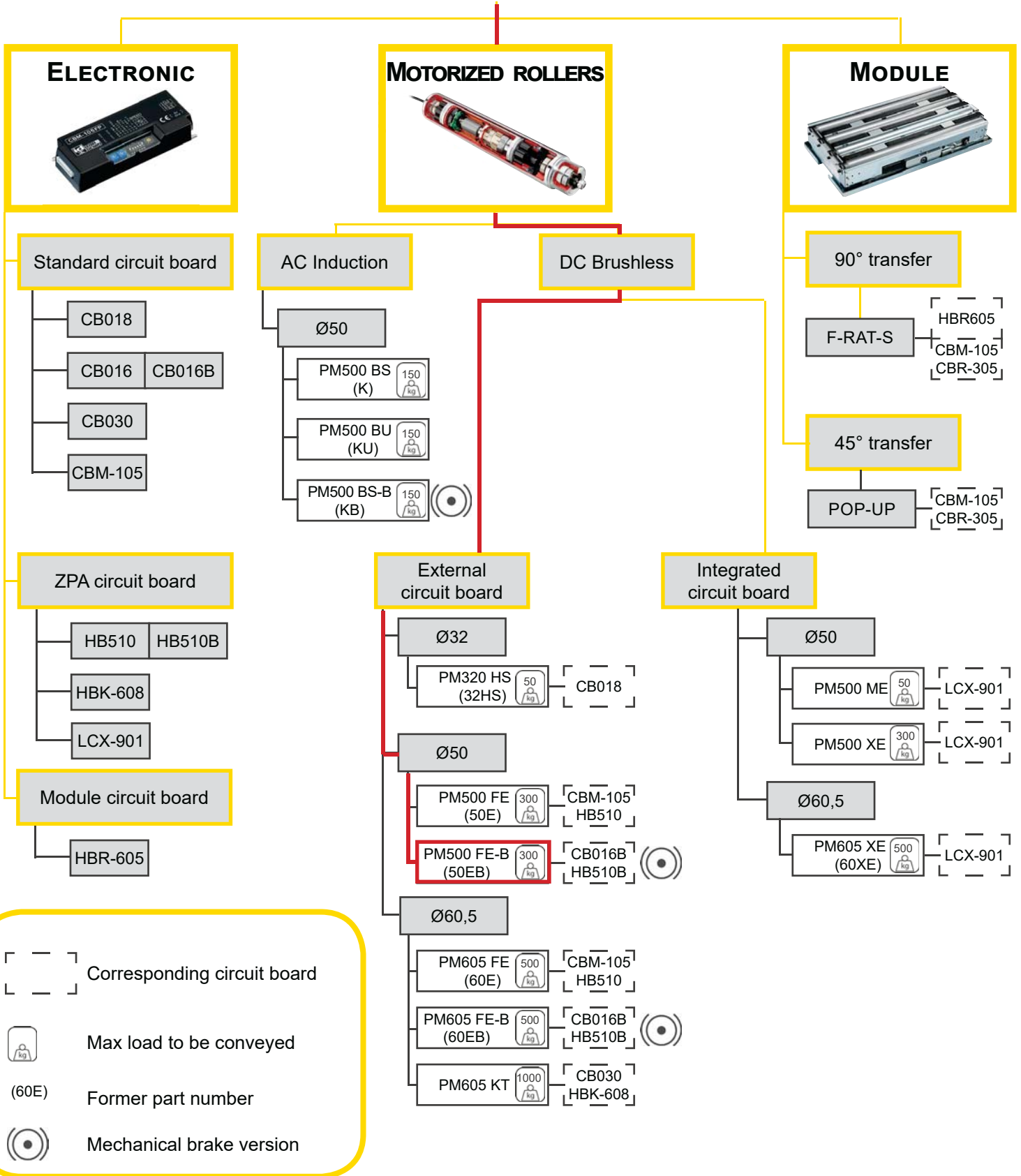

## 2 - PRESENTATION OF THE SERIES



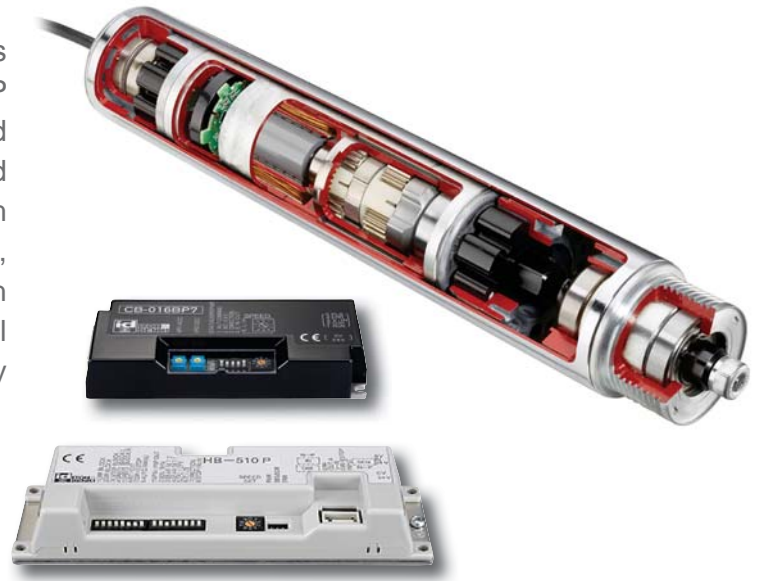









The motorized roller PM500FE-B with brushless technology 24VDC, used with circuit board CB016BP or HB510BP is designed for conveying light and medium loads for order preparation, distribution, and for assembly lines. This circuit board is separated from the gear-motor in order to optimize the performance, durability of the roller and to offer diverse functions such as pulse signals, acceleration/deceleration, optional position holder... The assembly can be controlled by PLC.



### General characteristics

<b>ELECTROMECHANICAL</b>	<b>Direct current and brushless 24 VDC</b>		24 VDC (+ /- 10 %) – ripple ratio < 10 %		
	<b>Isolation class</b>		E		
	<b>Operation at 40°C</b>	<b>Continuous</b>	100%		
		<b>Intermittent</b>	1800 starts / hour maxi Minimum duty cycle = 1 s ON / 1 s OFF ED = ON / (ON+OFF) ≤ 50 %		
	<b>Brake</b>		Dynamic braking, then mechanical braking-operated		
	<b>Protection index</b>		IP54 (IP65 or cold room, contact us)		
	<b>Cable length</b>		300 mm with JST connector - 9 pins		
	<b>Protection</b>		Thermal protection (>95°C for circuit board, >110°C for motor) Protection against induced voltage		
	<b>Environment</b>		0/+40 °C - no condensation - or corrosive or explosive atmosphere - Vibrations < 0,5 G		
	<b>Sound level</b>		≈ 52 dB nominal 1 metre away		
	<b>Speed code</b>		15	25	55
	<b>Reduction ratio</b>		1/44,90	1/26,67	1/12,64
	<b>Brake's torque (Nm)</b>		9,4	4,6	2,2
	<b>Absorbed brake power (W)</b>		2,5		
	<b>Absorbed current brake (A)</b>		0,21		
	<b>Action time of the mechanical brake</b>		200ms		
	<b>Connector</b>		Male 10-pin JST#S9B-XH-A		
<b>CONTROL</b>	<b>Circuit board functions</b>		See the characteristics of CB016BP (page 7) and HB510BP (page 8)		

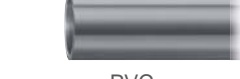
 The PM500FE-B motorized roller is designed exclusively for indoor use.

<p><b>Shaft and flange motor side :</b></p>	 Plain hexagonal  Threaded hexagonal	<ul style="list-style-type: none"> <li>• Plain hexagonal 11.1 mm shaft or M12 threaded</li> <li>• Heat-treated and phosphated steel shaft</li> <li>• Zamac (zinc, aluminium and magnesium alloy) endcaps</li> </ul>
<p><b>Shaft and flange free side :</b></p>	 Hexagonal spring loaded  Set screw	<ul style="list-style-type: none"> <li>• Smooth hexagonal 11.1mm shaft with spring, or shaft Ø15mm, 13mm M8 threaded flat metal strip</li> <li>• Heat-treated and phosphated steel shaft</li> <li>• Zamac (zinc, aluminium and magnesium alloy) flange</li> </ul>
<p><b>Tube :</b></p>	 Zinc plated steel  Stainless steel	<ul style="list-style-type: none"> <li>• Tube in precision cold drawn steel, ST37-2 quality, outer diam. 50 mm</li> <li>• Zinc-coated or stainless steel (304L)</li> </ul>
<p><b>Pulleys :</b></p>	 Ribbed  Grooves	<ul style="list-style-type: none"> <li>• Ribbed belts, 8 teeth, Zamac (zinc, aluminium and magnesium alloy) with smooth hexagonal shaft with spring or M8 threaded</li> <li>• Round belts, diam. 4 or 5 mm with smooth</li> <li>• Hexagonal shaft with spring or M8 threaded shaft</li> </ul>
<p><b>Grooves :</b></p>	 Grooves	<ul style="list-style-type: none"> <li>• Grooves in different positions from 33 to 300 mm from the edge of the tube</li> <li>• Depth 5,8mm</li> <li>• For round belts Ø 4 or 5 mm</li> </ul>
<p><b>Sleeve :</b></p>	 Tapered  PVC	<ul style="list-style-type: none"> <li>• Conical PVC sleeve (PP) for inner radius (Ri) 800 or 850 mm</li> <li>• Grey/black PVC sleeve thickness 2 or 3 mm (58 ShA)</li> </ul>
<p><b>Lagging :</b></p>	 Polyurethane  Natural rubber / nitrile	<ul style="list-style-type: none"> <li>• Polymerized polyurethane coating, thickness 3 mm, 90 ShA, grey</li> <li>• Natural hot vulcanized rubber coating, thickness 3 mm, 60~65 Sha</li> </ul>

**Structure and description**

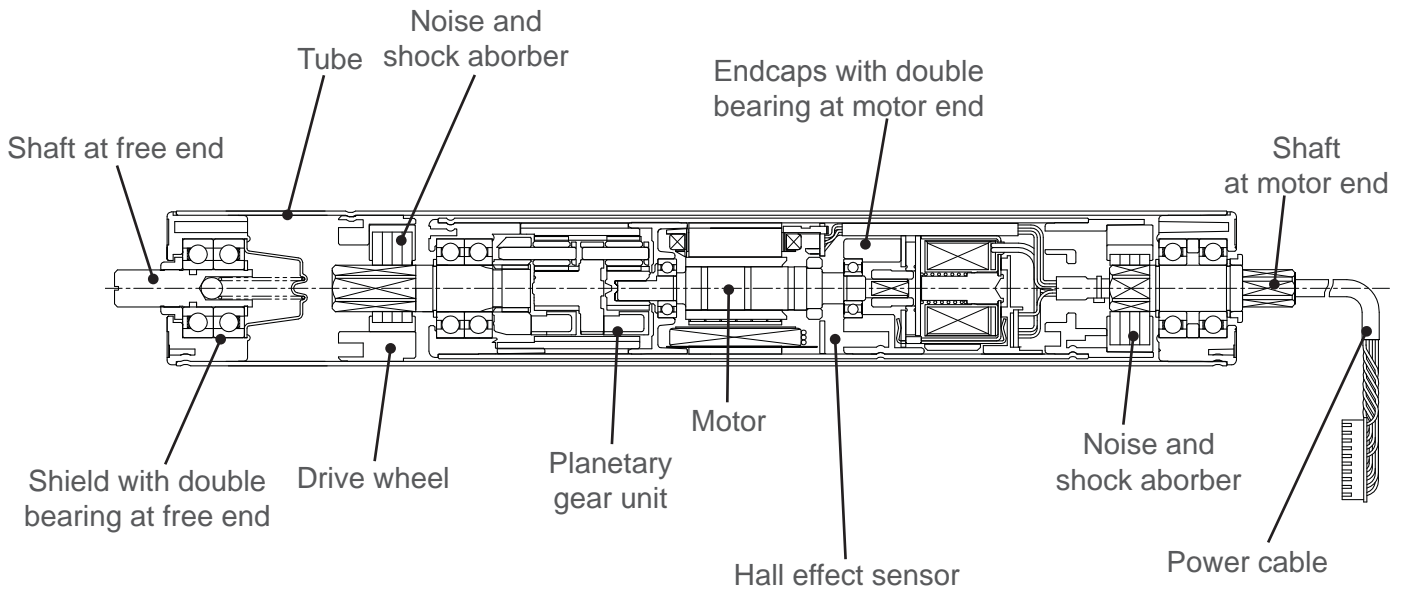

**Applications**

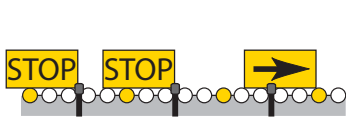

Zero pressure accumulation (ZPA)

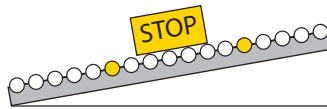

Position holding

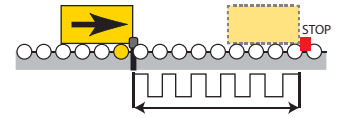

Stopping distance controlled by pulsed signal (CB016BP)

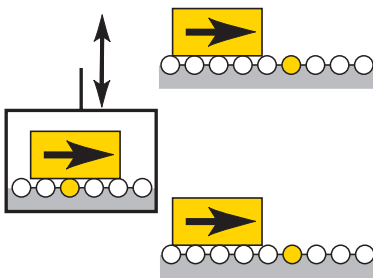

Lift

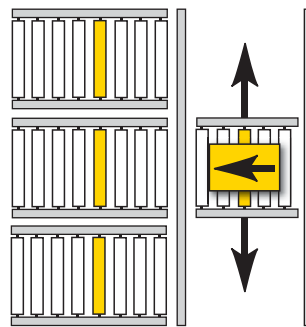

Cross transfer

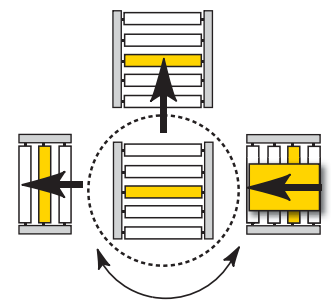

Turn table

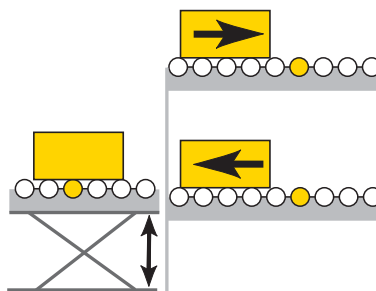

Lift table



## Characteristics depending on circuit board

### WITH CB016BP

CHARACTERISTICS		SPEED CODE 15	SPEED CODE 25	SPEED CODE 55	
ELECTROMECHANIC	Motor	Direct current and brushless 24 VDC			
	Absorbed power (W)	nominal	25 - 67,2		
		start-up	96		
	Tangential force (N)	nominal	133,9 - 143,9	78 - 86	42,8 - 46
		start-up	349,8	225	111,8
	Operation	Continuous or intermittent 1800 starts/h max. Minimum duty cycle : 1s ON / 1s OFF			
	Brake	Type	Mechanical braking then dynamic braking-operated		
		Absorbed power (W)	2,5		
		Torque (Nm)	9,4	4,6	2,2
	Speed (m/min)	no load	2,2 - 17,4	3,7 - 29,3	7,7 - 61,7
nominal		2,2 - 13,3	3,7 - 25,4	7,7 - 47,3	
Protection index (motorized roller)	IP54, 65 ( <i>Contact us for other classes</i> )				
Lenght	350 to 1200 mm	325 to 1200 mm	325 to 1200 mm		
Static load max.	300 - 1200 mm = 65 - 15 kg per roller				
CONTROL	Input signal	Start / Stop, Direction of rotation			
	Selection of rotation direction	By dip switch (CW/CCW) or input signal			
	Speed setting	20 speeds with a rotating switch			
		20 speeds by external analog voltage of 0-10VDC			
	Acceleration / Deceleration	Adjustable with potentiometer from 0 to 2,5s			
	Servo-brake activation	ON/OFF by dip switch			
	Pulse signal output (imp./tour)	89,9	53,34	25,28	
	Error signal out-put	Over-heating, wiring error, under-voltage, over-voltage...			
Protection	Against polarity reversal 0/24V and power backfeed, fuse, integrated thermal protection				

*For other specifications, please contact us.*

## WITH HB510BP

CHARACTERISTICS		SPEED CODE 15	SPEED CODE 25	SPEED CODE 55	
<b>ELECTROMECHANIC</b>	Motor	Direct current and brushless 24 VDC			
	Absorbed power (W)	nominal	29,3 - 60	28,8 - 61,9	29,3 - 60
		start-up	96		
	Tangential force (N)	nominal	118,6 - 127,1	67,7 - 75,0	37,9 - 40,6
		start-up	349,8	225,5	111,8
	Operation	Continuous or intermittent 1800 starts/h max. Minimum duty cycle : 1s ON / 1s OF			
	Brake	Type	Mechanical braking then dynamic braking-operated		
		Absorbed power (W)	2,5		
		Torque (Nm)	9,4	4,6	2,2
	Nominal speed (m/min)	no load	4,3 - 17,4	7,3 - 29,3	15,4 - 61,7
nominal		4,3 - 13,9	7,3 - 26,3	15,4 - 49,4	
Protection index (motor roller)	IP54, 65, cold room ( <i>Contact us for other classes</i> )				
Lenght	350 to 1200 mm	325 to 1200 mm	325 to 1200 mm		
Static load max.	300 - 1200 mm = 65 - 15 kg per roller				
<b>CONTROL</b>	Speed setting	10 speeds with a rotating switch			
		10 speeds by external analog voltage of 0-10VDC			
	Error signal in-put	Over-heating, wiring error, under-voltage, over-voltage...			
	Sensor output signal	Recovery sensor state for PLC			
	Protection	Against polarity reversal 0/24V and power backfeed, fuse, integrated thermal protection			
	Sensor timer	Timing sequence of the motorized roller depending on the sensor status of the downstream zone			
	Run holding timer	Timing sequence of the motorized roller depending on the sensor status of the zone to be left			
	Jam timer	Jam/blockage detection of the load depending on the sensor status time			
	Emergency stop	Stop of the motorized rollers of all the defined zones			
	Transfer mode	Selection of train mode or singulation mode by dip switch			
	Transfer direction and logic	Invert the direction of travel and logic for all the defined zones			
	Synchronization function	Synchronization of several motorized rollers in the same zone			
	Forced Start / Forced Stop	The forced start enables evacuating the load of the last zone The forced stop enables inserting load in a defined location			
	Speed control block area	Speed variation simultaneous and synchronized of several motorized rollers			
Modification program	Contact us				

### 3 - TRANSFER CAPACITY

Driven by ribbed belts

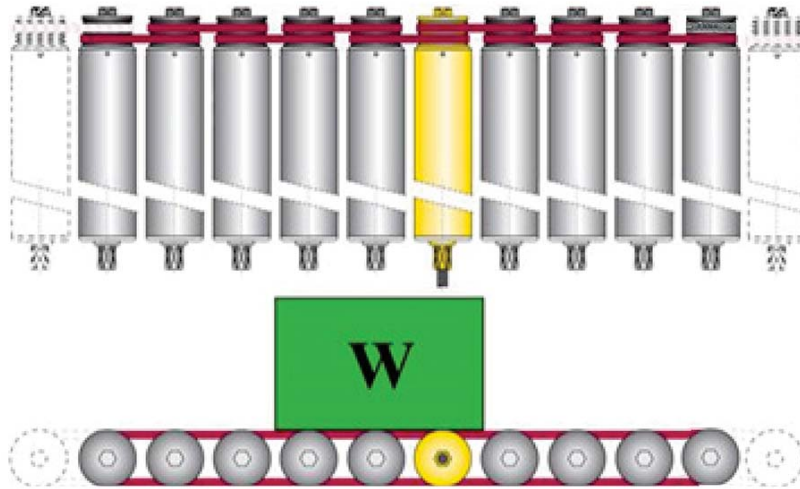

WITH CB016BP

PM500FE-B 15m/min

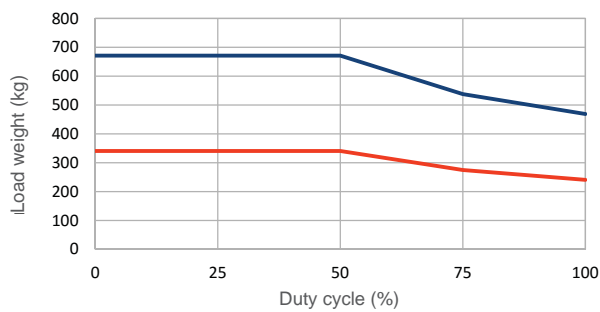

PM500FE-B 25m/min

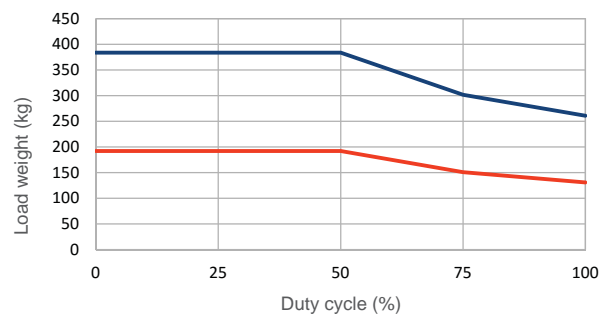

PM500FE-B 55m/min

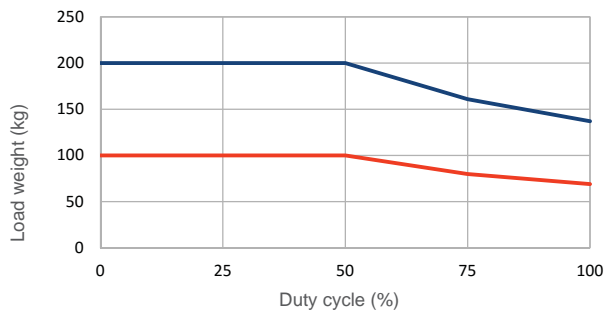

- Load to transport
  - Plastic box ( $\mu = 0,03$ )
  - Cardboard box ( $\mu = 0,06$ )
- 9 slave rollers driven by 1 motorized roller



These curves are given as a guide. Transfer capacity depends on the nature and quality of the transported load, the belt tension, the quality of the bearings, the nature of the sleeves, the ambient temperature...

Due to the maximum static load of the PM500FE which is 300 kg max, note that practically the PM500FE can't convey more than 300 kg but the above curves are giving an idea of the theoretical limits of the PM500FE.

## WITH HB510BP

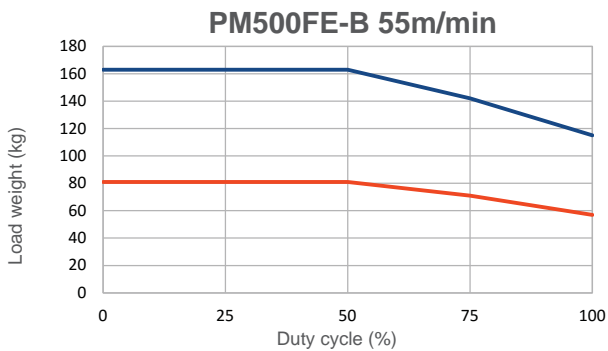
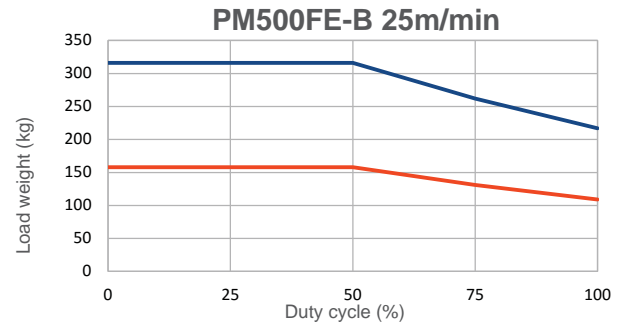
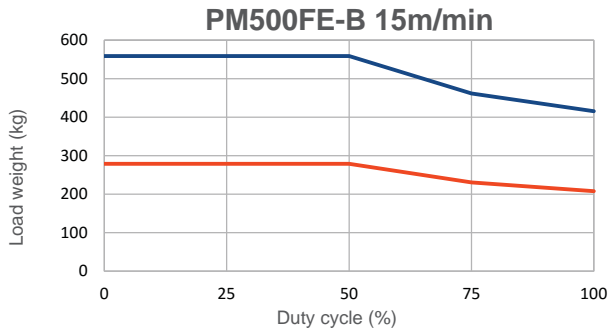











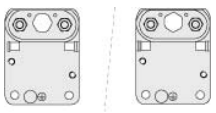
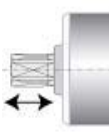

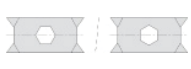

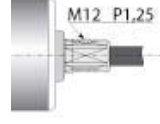

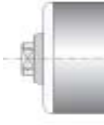

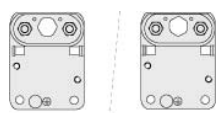
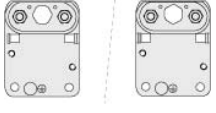
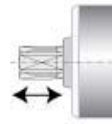

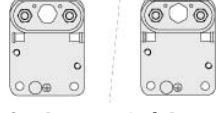
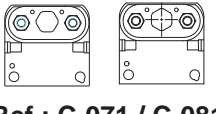
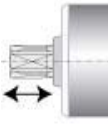
- Load to transport
  - Plastic box ( $\mu = 0,03$ )
  - Cardboard box ( $\mu = 0,06$ )
- 9 slave rollers driven by 1 motorized roller

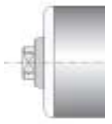

*These curves are given as a guide. Transfer capacity depends on the nature and quality of the transported load, the belt tension, the quality of the bearings, the nature of the sleeves, the ambient temperature...*

*Due to the maximum static load of the PM500FE-B which is 300 kg max, note that practically the PM500FE-B can't convey more than 300 kg but the above curves are giving an idea of the theoretical limits of the PM500FE-B.*

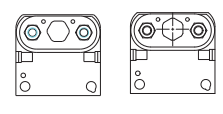
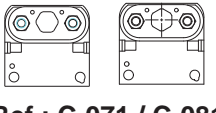
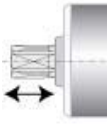
## 4 - PRESENTATION OF THE DIFFERENT FIXING OPTIONS

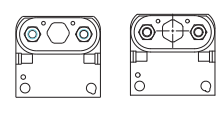
FREE SIDE FIXING		MOTOR SIDE FIXING	
 <b>Ref : A-071-G / A-081-G</b> <i>(optional)</i>			 <b>Ref : P-0B1 / P-0C1</b> <i>(obligatory)</i>
 <b>Vis M8 x 14</b> <i>(obligatory)</i>			 <b>Ref : P-0B1 / P-0C1</b> <i>(obligatory)</i>
			 <b>Ref : A-071-G / A-081-G</b> <i>(obligatory)</i>
 <b>Ref : A-071-G / A-081-G</b> <i>(optional)</i>			 <b>Ref : A-071-G / A-081-G</b> <i>(obligatory)</i>
 <b>Ref : C-071 / C-081</b> <i>(optional)</i>			 <b>Ref : P-0B1 / P-0C1</b> <i>(obligatory)</i>
 <b>Vis M8 x 14</b> <i>(obligatory)</i>			 <b>Ref : P-0B1 / P-0C1</b> <i>(obligatory)</i>
			 <b>Ref : C-071 / C-081</b> <i>(optional)</i>
 <b>Ref : C-071 / C-081</b> <i>(optional)</i>			 <b>Ref : C-071 / C-081</b> <i>(optional)</i>

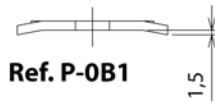
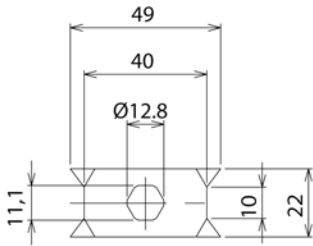

**Ref. P-0B1**

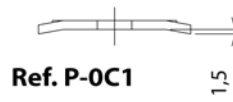
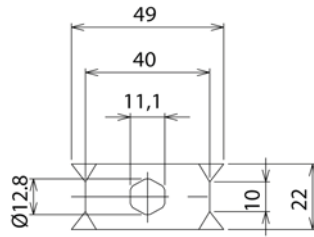
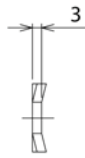

**Ref. P-0C1**

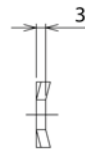

**Ref. FEY01**

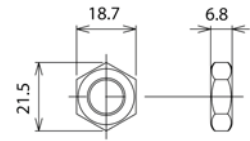

**Note :**  
 Nut ref. FEY01 should be used with the claw plate ref. P-0B1 or P-0C1.

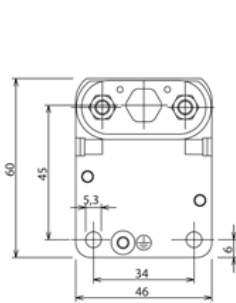

**Ref. A-071-G**

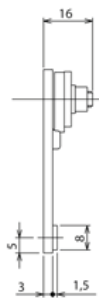

2 nuts M5  
 2 cruciform bolt M5x15  
 2 spring washer M5

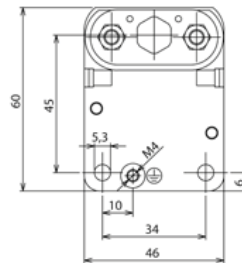

**Ref. A-081-G**

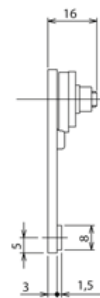

2 nuts M5  
 2 cruciform bolt M5x15  
 2 spring washer M5

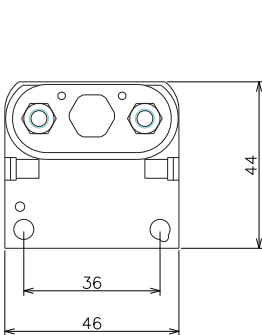

**Ref. C-071**

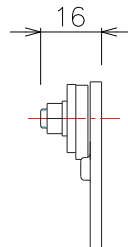

2 nuts M5  
 2 cruciform bolt M5x15  
 2 spring washer M5

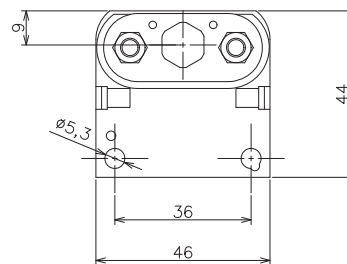

**Ref. C-081**

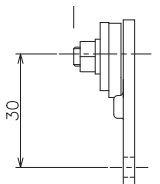

2 spring washer M5  
 2 nuts M5  
 2 cruciform bolt M5x15

## 5 - DIMENSIONAL CHARACTERISTICS

### Grooved tube - Hexagonal shaft with spring on free end

**PM500FE-B (50EB)** - Hexagonal threaded shaft motor side and hexagonal shaft with spring on free end

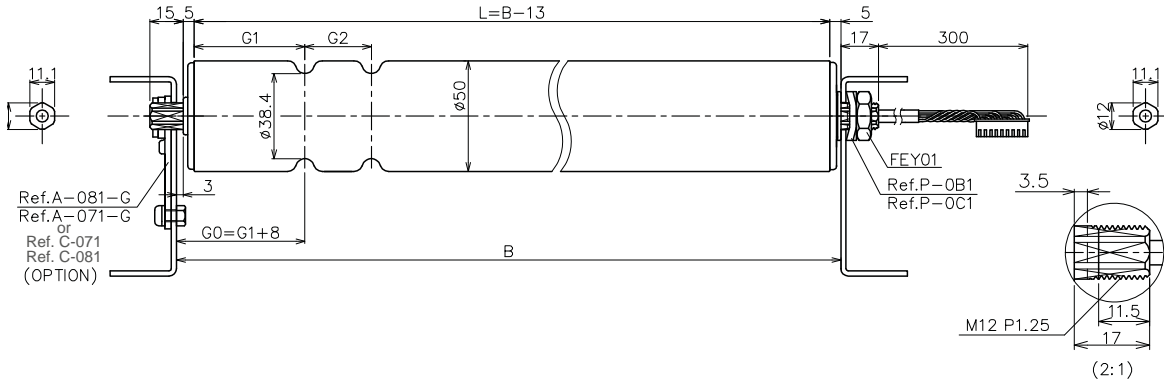

**PM500FE-B (50EB)** - Hexagonal plain shaft motor side and hexagonal shaft with spring on free end

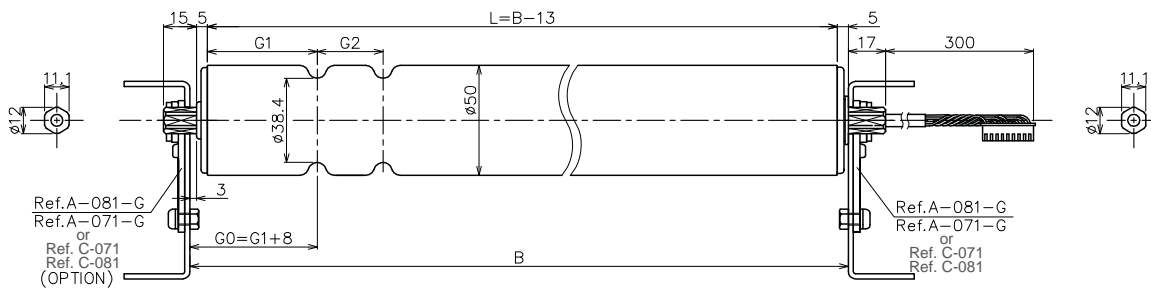

Dimensions PM500FE-B (50EB)

#### STEEL TUBE

Speed code	Dimension (B)	Tube length (L)	Grooves for steel tube Depth = 5.8mm			
	mini ≤ B ≤ max	mini ≤ L ≤ max	G0 mini	G1 mini	G2 mini	G1+G2 max
15	$348+G1+G2 \leq B \leq 1213$	$335+G1+G2 \leq L \leq 1200$	≥ 41	≥ 33	≥ 22	≤ 300
25 / 55	$318+G1+G2 \leq B \leq 1213$	$305+G1+G2 \leq L \leq 1200$				

#### STAINLESS STEEL TUBE

Speed code	Dimension (B)	Tube length (L)	Grooves for stainless steel tube Depth = 5,2mm			
	mini ≤ B ≤ max	mini ≤ L ≤ max	G0 mini	G1 mini	G2 mini	G1 + G2 max
15	$348+G1+G2 \leq B \leq 1213$	$270+G1+G2 \leq L \leq 1200$	≥ 41	≥ 33	≥ 30	≤ 300
25 / 55	$318+G1+G2 \leq B \leq 1213$	$240+G1+G2 \leq L \leq 1200$				

#### WEIGHT / STATIC LOAD / AXIAL FORCE

Tube length		350	400	500	600	700	800	900	1000	1100	1200
Weight (Kg)	15 m/min	3,1	3,2	3,3	3,5	3,7	3,8	4,0	4,2	4,3	4,5
	25m/min	2,8	2,9	3,1	3,2	3,4	3,6	3,7	3,9	4,1	4,2
	55m/min	2,9	3,0	3,1	3,2	3,5	3,6	3,8	3,9	4,1	4,3
Static load max (kg)		65	55	45	35	30	25	20	20	15	15
Axial force max (N)		290									

**Grooved tube - M8 threaded shaft with screw on free end**

**PM500FE-B (50EB)** - Hexagonal threaded shaft motor side and M8 threaded shaft with screw on free end

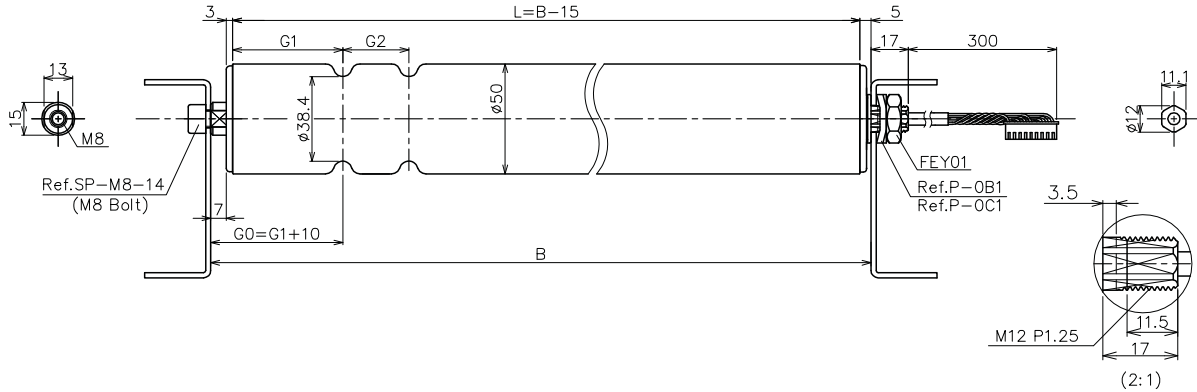

**PM500FE-B (50EB)** - Hexagonal plain shaft motor side and M8 threaded shaft with screw on free end

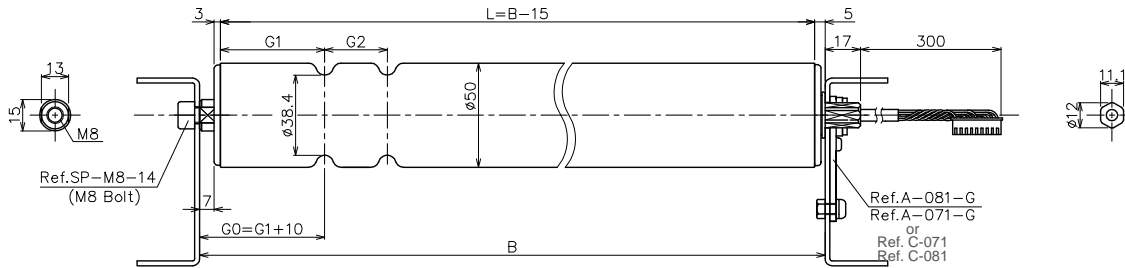

**Dimensions PM500FE-B (50EB)**

**STEEL TUBE**

Speed code	Dimension (B)	Tube length (L)	Grooves for steel tube Depth = 5.8mm			
	mini ≤ B ≤ max	mini ≤ L ≤ max	G0 mini	G1 mini	G2 mini	G1+G2 max
15	350+G1+G2 ≤ B ≤ 1213	335+G1+G2 ≤ L ≤ 1200	≥ 43	≥ 33	≥ 22	≤ 300
25 / 55	320+G1+G2 ≤ B ≤ 1213	305+G1+G2 ≤ L ≤ 1200				

**STAINLESS STEEL TUBE**

Speed code	Dimension (B)	Tube length (L)	Grooves for stainless steel tube Depth = 5.2mm			
	mini ≤ B ≤ max	mini ≤ L ≤ max	G0 mini	G1 mini	G2 mini	G1+G2 max
15	350+G1+G2 ≤ B ≤ 1213	335+G1+G2 ≤ L ≤ 1200	≥ 43	≥ 33	≥ 30	≤ 300
25 / 55	320+G1+G2 ≤ B ≤ 1213	305+G1+G2 ≤ L ≤ 1200				

**WEIGHT / STATIC LOAD / AXIAL FORCE**

Tube length		350	400	500	600	700	800	900	1000	1100	1200
Weight (Kg)	15 m/min	3,1	3,2	3,3	3,5	3,7	3,8	4,0	4,2	4,3	4,5
	25m/min	2,8	2,9	3,1	3,2	3,4	3,6	3,7	3,9	4,1	4,2
	55m/min	2,9	3,0	3,1	3,3	3,4	3,6	3,8	3,9	4,1	4,3
Static load max (kg)		65	55	45	35	30	25	20	20	15	15
Axial force max (N)		290									



**Roller with pulley for ribbed belt - Hexagonal shaft with spring on free end**

**PM500FE-B (50EB)** - Hexagonal threaded shaft motor side and hexagonal shaft with spring on free end

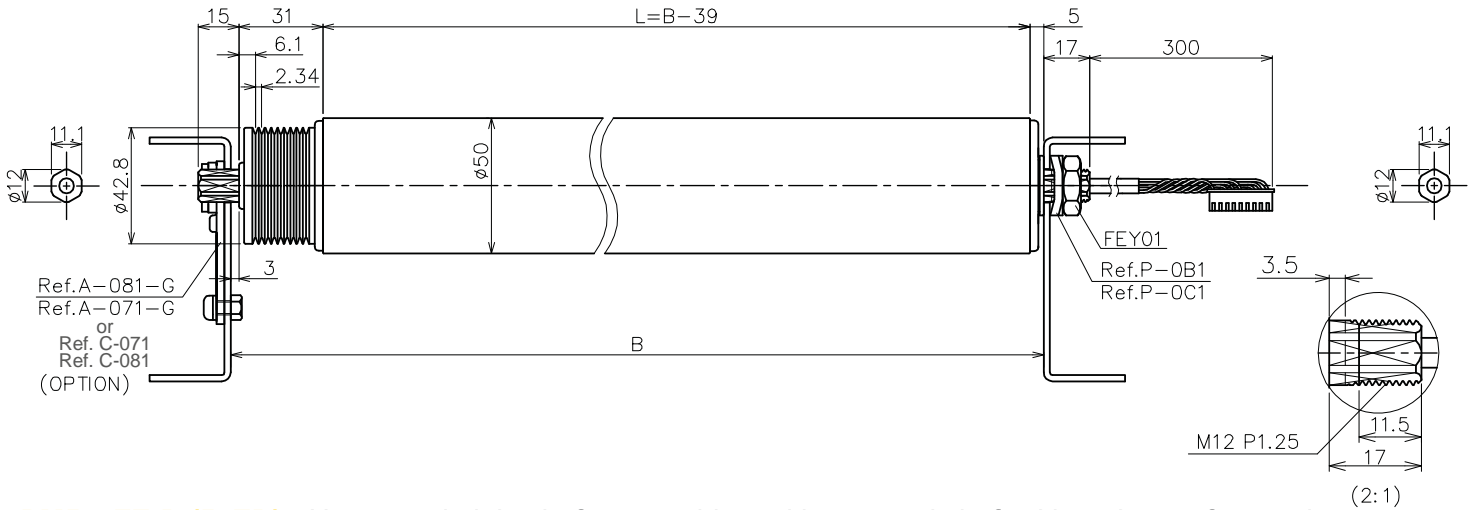

**PM500FE-B (50EB)** - Hexagonal plain shaft motor side and hexagonal shaft with spring on free end

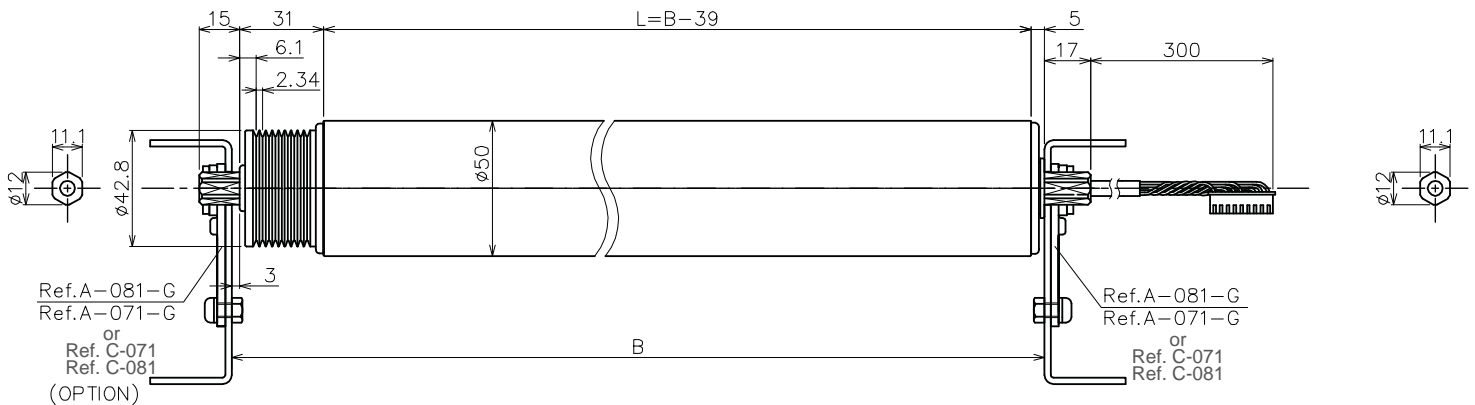

**Dimensions PM500FE-B (50EB)**

Speed code	Dimension (B)	Tube length (L)
	mini ≤ B ≤ max	mini ≤ L ≤ max
15	399 ≤ B ≤ 1239	360 ≤ L ≤ 1200
25 / 55	374 ≤ B ≤ 1239	335 ≤ L ≤ 1200

**WEIGHT / STATIC LOAD / AXIAL FORCE**

Tube length		350	400	500	600	700	800	900	1000	1100	1200
Weight (Kg)	15 m/min	/	3,3	3,5	3,7	3,8	4,0	4,1	4,3	4,5	4,6
	25m/min	3,0	3,1	3,2	3,4	3,6	3,7	3,9	4,1	4,2	4,4
	55m/min	3,0	3,1	3,2	3,4	3,6	3,8	3,9	4,1	4,3	4,4
Static load max (kg)		65	55	45	35	30	25	20	20	15	15
Axial force max (N)		290									

■ Roller with pulley for ribbed belt - M8 threaded shaft with screw on free end .....

PM500FE (50EB) - Hexagonal threaded shaft motor side and M8 threaded shaft with screw on free end

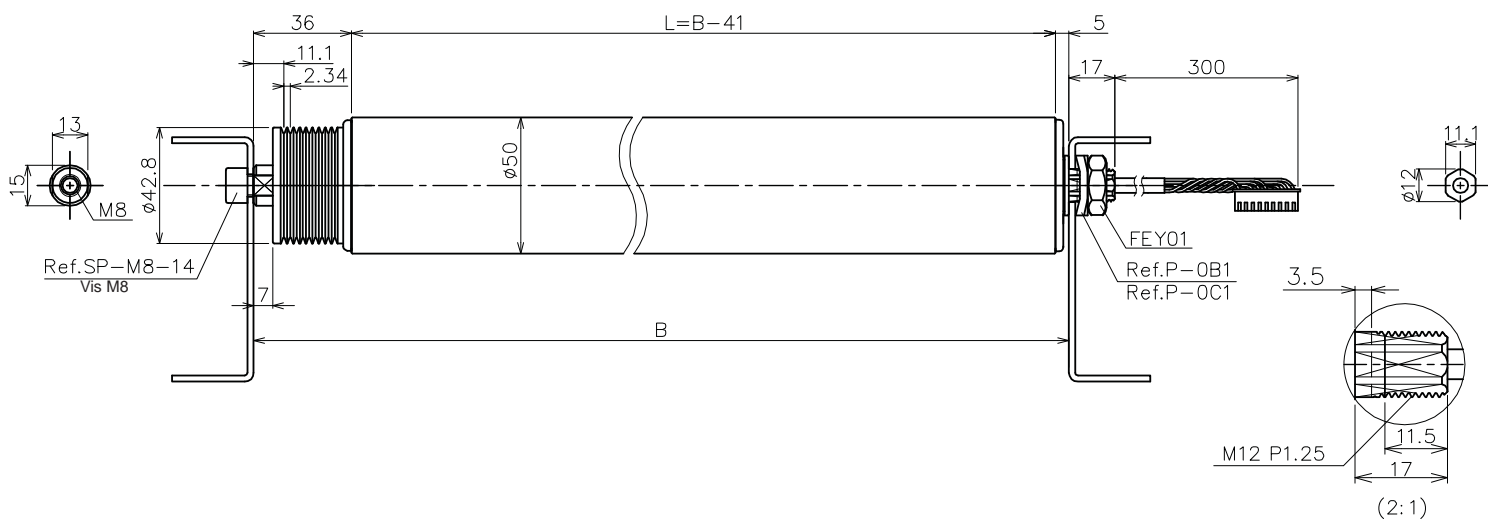

PM500FE (50EB) - Hexagonal plain shaft motor side and M8 threaded shaft with screw on free end

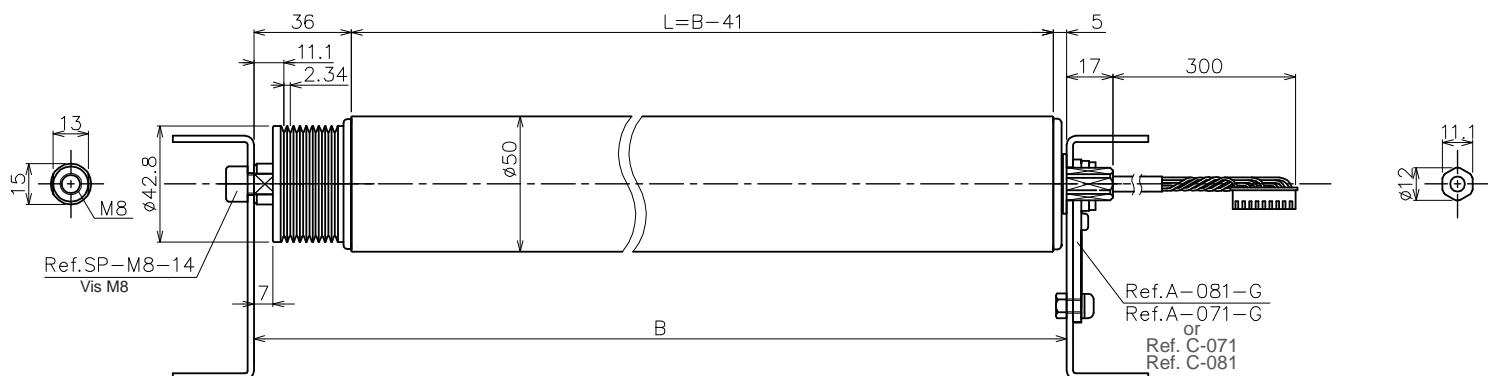

Dimensions PM500FE-B (50EB)

Speed code	Dimension (B)	Tube length (L)
	mini ≤ B ≤ max	mini ≤ L ≤ max
15	391 ≤ B ≤ 1241	350 ≤ L ≤ 1200
25 / 55	366 ≤ B ≤ 1241	325 ≤ L ≤ 1200

WEIGHT / STATIC LOAD / AXIAL FORCE

Tube length		350	400	500	600	700	800	900	1000	1100	1200
Weight (Kg)	15 m/min	3,2	3,3	3,4	3,6	3,8	3,9	4,1	4,2	4,4	4,6
	25m/min	2,9	3,0	3,2	3,3	3,5	3,7	3,8	4,0	4,1	4,3
	55m/min	3,0	3,0	3,2	3,4	3,5	3,7	3,9	4,0	4,2	4,4
Static load max (kg)		65	55	45	35	30	25	20	20	15	15
Axial force max (N)		290									

**Roller with pulley for round belt - Hexagonal shaft with spring on free end**

**PM500FE-B (50EB)** - Hexagonal threaded shaft motor side and hexagonal shaft with spring on free end

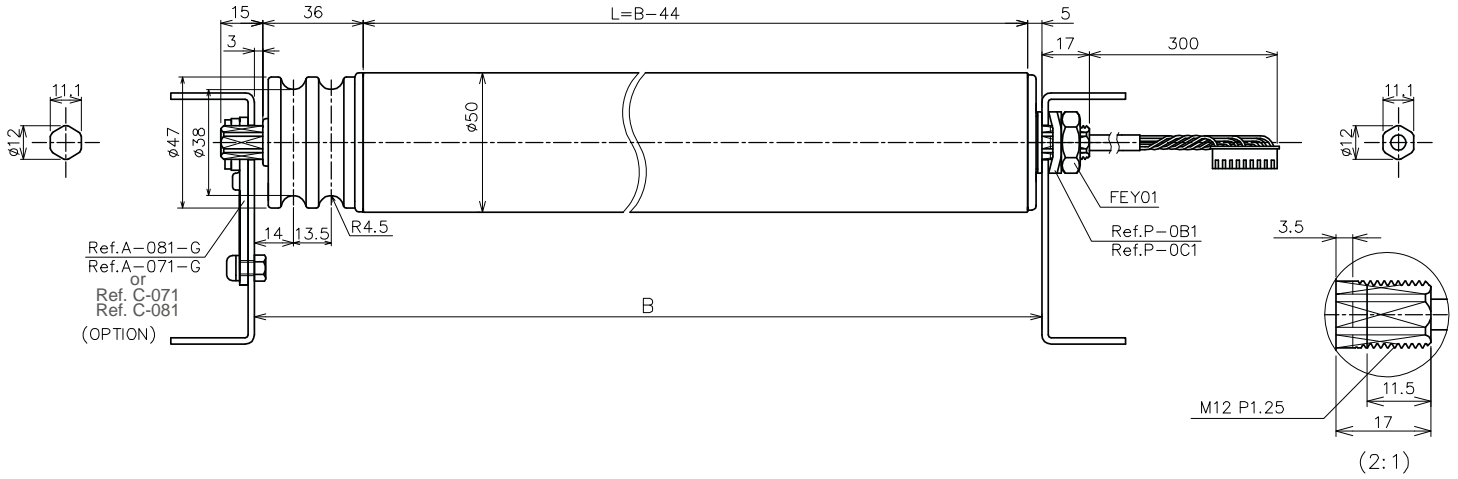

**PM500FE-B (50EB)** - Hexagonal plain shaft motor side and hexagonal shaft with spring on free end

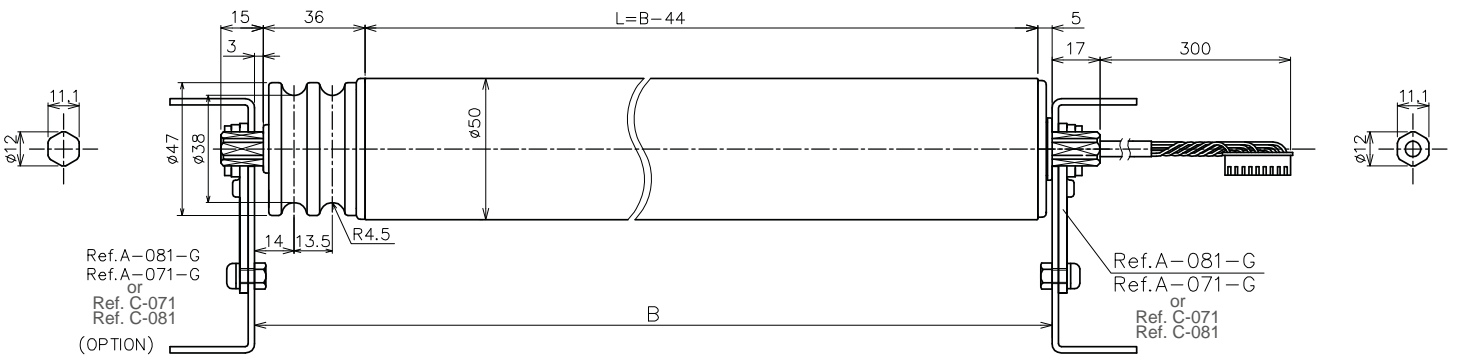

**Dimensions PM500FE-B (50EB)**

Speed code	Dimension (B)	Tube length (L)
	mini ≤ B ≤ max	mini ≤ L ≤ max
15	404 ≤ B ≤ 1244	360 ≤ L ≤ 1200
25 / 55	379 ≤ B ≤ 1244	335 ≤ L ≤ 1200

**WEIGHT / STATIC LOAD / AXIAL FORCE**

Tube length		350	400	500	600	700	800	900	1000	1100	1200
Weight (Kg)	15 m/min		3,3	3,5	3,7	3,8	4,0	4,1	4,3	4,5	4,6
	25m/min	3,0	3,1	3,2	3,4	3,6	3,7	3,9	4,1	4,2	4,4
	55m/min	3,0	3,1	3,2	3,4	3,6	3,8	3,9	4,1	4,3	4,4
Static load max (kg)		65	55	45	35	30	25	20	20	15	15
Axial force max (N)		290									

## Roller with pulley for round belt - M8 threaded shaft with screw on free end

**PM500FE-B (50EB)** - Hexagonal threaded shaft motor side and M8 threaded shaft with screw on free end

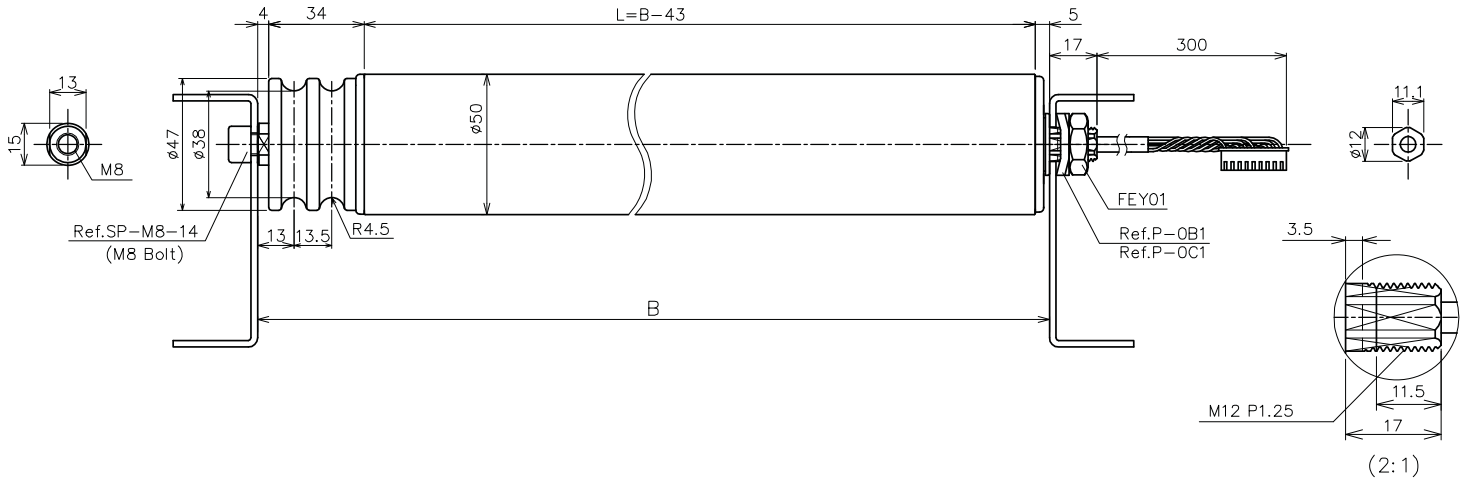

**PM500FE-B (50EB)** - Hexagonal plain shaft motor side and M8 threaded shaft with screw on free end

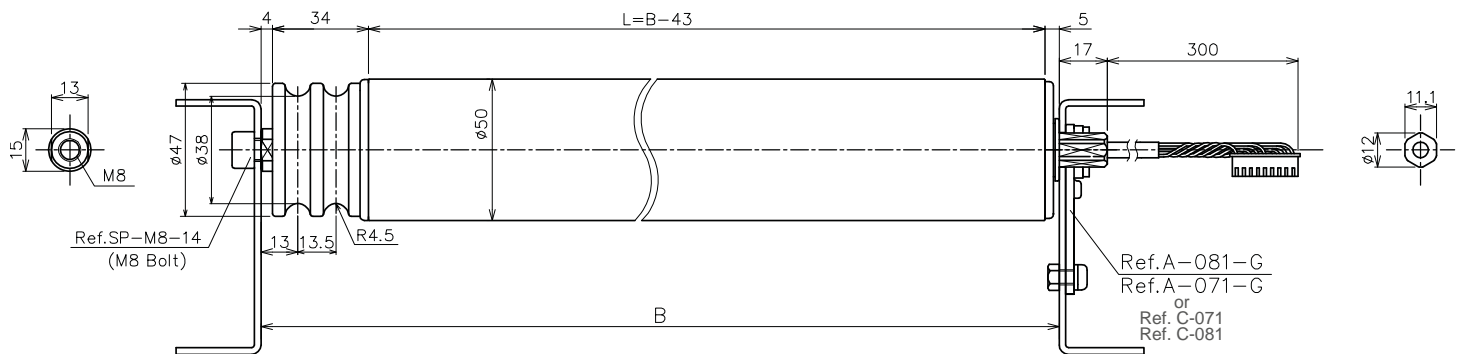

**Dimensions PM500FE-B (50EB)**

Speed code	Dimension (B)	Tube length (L)
	mini ≤ B ≤ max	mini ≤ L ≤ max
15	393 ≤ B ≤ 1244	350 ≤ L ≤ 1200
25 / 55	368 ≤ B ≤ 1244	325 ≤ L ≤ 1200

### WEIGHT / STATIC LOAD / AXIAL FORCE

Tube length		350	400	500	600	700	800	900	1000	1100	1200
Weight (Kg)	15 m/min	3,2	3,3	3,4	3,6	3,8	3,9	4,1	4,2	4,4	4,6
	25m/min	2,9	3,0	3,2	3,3	3,5	3,7	3,8	4,0	4,1	4,3
	55m/min	3,0	3,1	3,2	3,4	3,5	3,7	3,9	4,0	4,2	4,4
Static load max (kg)		65	55	45	35	30	25	20	20	15	15
Axial force max (N)		290									

## Roller without drive - Hexagonal shaft with spring on free end

**PM500FE-B (50EB)** - Hexagonal threaded shaft motor side and hexagonal shaft with spring on free end

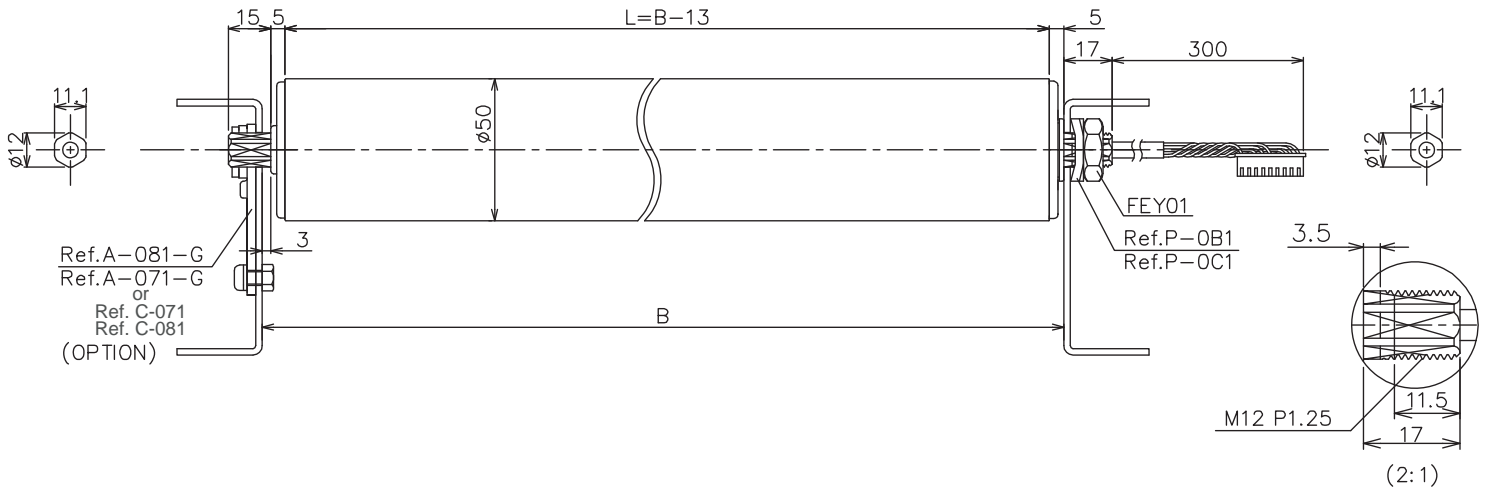

**PM500FE-B (50EB)** - Hexagonal plain shaft motor side and hexagonal shaft with spring on free end

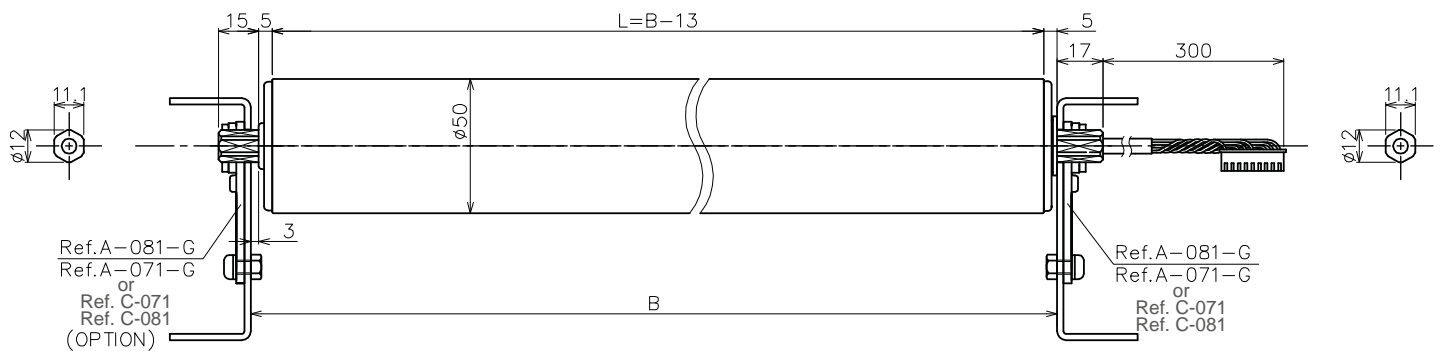

**Dimensions PM500FE-B (50EB)**

Speed code	Dimension (B)	Tube length (L)
	mini ≤ B ≤ max	mini ≤ L ≤ max
15	373 ≤ B ≤ 1213	360 ≤ L ≤ 1200
25 / 55	348 ≤ B ≤ 1213	335 ≤ L ≤ 1200

### WEIGHT / STATIC LOAD / AXIAL FORCE

Tube length		350	400	500	600	700	800	900	1000	1100	1200
Weight (Kg)	15 m/min	/	3,2	3,3	3,5	3,7	3,8	4,0	4,2	4,3	4,5
	25m/min	2,8	2,9	3,1	3,2	3,4	3,6	3,7	3,9	4,1	4,2
	55m/min	2,8	3,0	3,1	3,2	3,5	3,6	3,8	3,9	4,1	4,3
Static load max (kg)		65	55	45	35	30	25	20	20	15	15
Axial force max (N)		290									

**Roller without drive - M8 threaded shaft with screw on free end**

**PM500FE-B (50EB)** - Hexagonal threaded shaft motor side and M8 threaded shaft with screw on free end

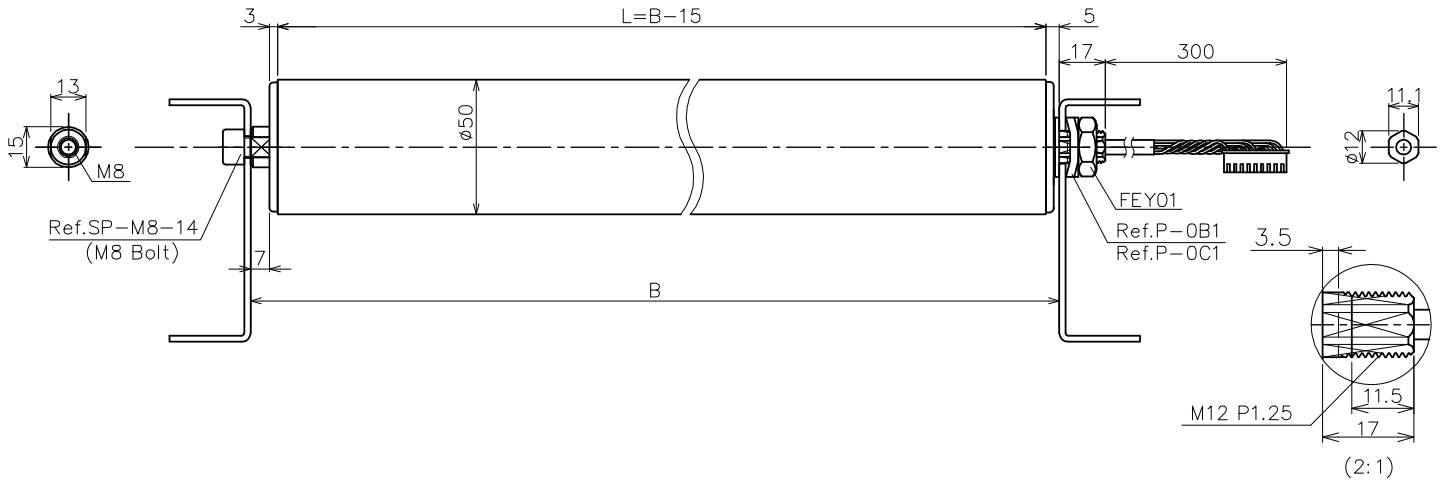

**PM500FE-B (50EB)** - Hexagonal plain shaft motor side and M8 threaded shaft with screw on free end

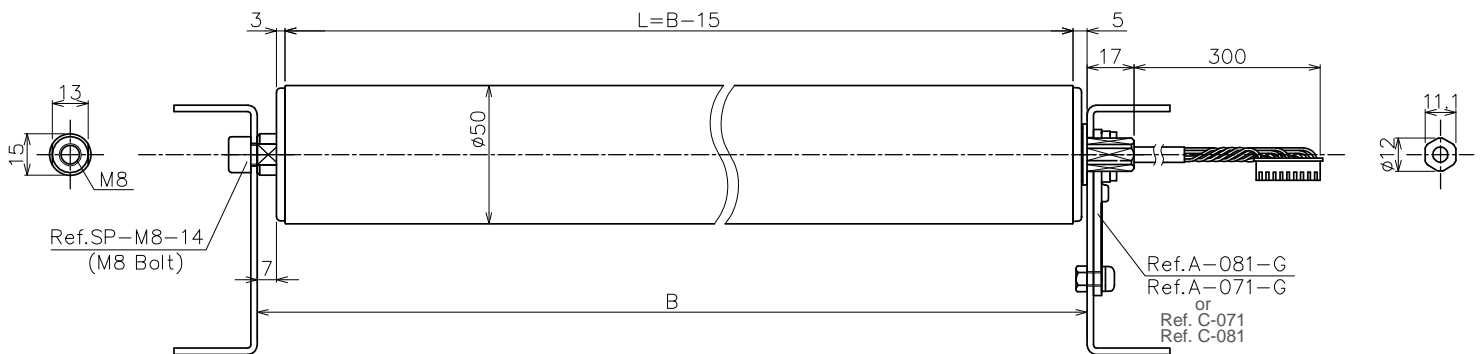

**Dimensions PM500FE-B (50EB)**

Speed code	Dimension (B)	Tube length (L)
	mini ≤ B ≤ max	mini ≤ L ≤ max
15	365 ≤ B ≤ 1215	350 ≤ L ≤ 1200
25 / 55	340 ≤ B ≤ 1215	325 ≤ L ≤ 1200

**WEIGHT / STATIC LOAD / AXIAL FORCE**

Tube length		350	400	500	600	700	800	900	1000	1100	1200
Weight (Kg)	15 m/min	/	3,2	3,3	3,5	3,7	3,8	4,0	4,2	4,3	4,5
	25m/min	2,7	2,9	3,1	3,2	3,4	3,6	3,7	3,9	4,1	4,2
	55m/min	2,8	3,0	3,1	3,3	3,4	3,6	3,8	3,9	4,1	4,3
Static load max (kg)		65	55	45	35	30	25	20	20	15	15
Axial force max (N)		290									

## 6 - DIMENSIONAL CHARACTERISTICS - MISCELLANEOUS

### PVC sleeve

For conveying a fragile load or to lower the sound level.  
Sleeved by compressed air

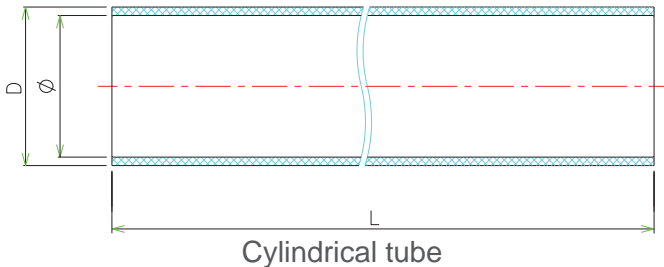

Thickness (mm)	L (mm)	Ø (mm)	D (mm)	Hardness
2	≤1200	50	54	~58 shore A
3			56	

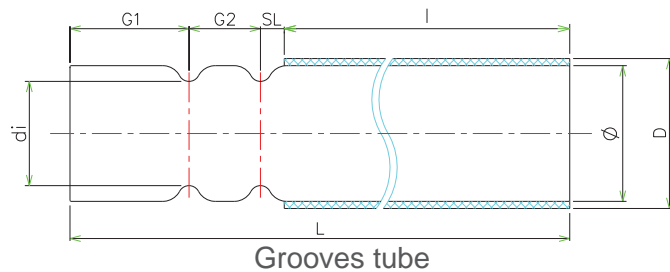

Thickness (mm)	L (mm)	Ø (mm)	D (mm)	SL (mm)
2	≤1200	50	54	10
3			56	

### Coated in natural rubber, nitrile rubber and polyurethane

Material	Characteristics	Hardness (ShA)	Thickness (mm)
Natural rubber	It improves the adherence of the products conveyed and reduces noise. Do not use in contact with hydrocarbon, oil or grease.	60~65	3
Nitrile rubber	Exceptional resistance in the presence of hydrocarbon, oil and grease.		
Polyurethane	High resistance to abrasion, tearing and oil.	90	

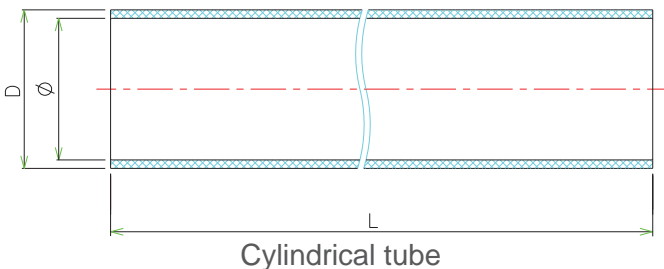

L (mm)	Ø (mm)	D (mm)
≤1000	50	56

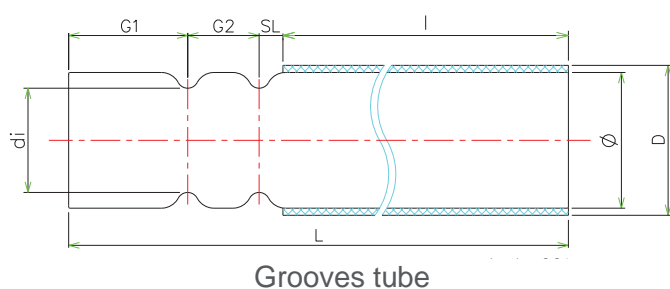

L (mm)	Ø (mm)	D (mm)	SL (mm)
≤1000	50	56	10

## 7 - BELT CONVEYOR APPLICATION

### Condition of use and recommendation

The PM500FE motorized roller allows to create a conveyor with very small dimensions to convey light loads, provided that the hereafter conditions are followed :

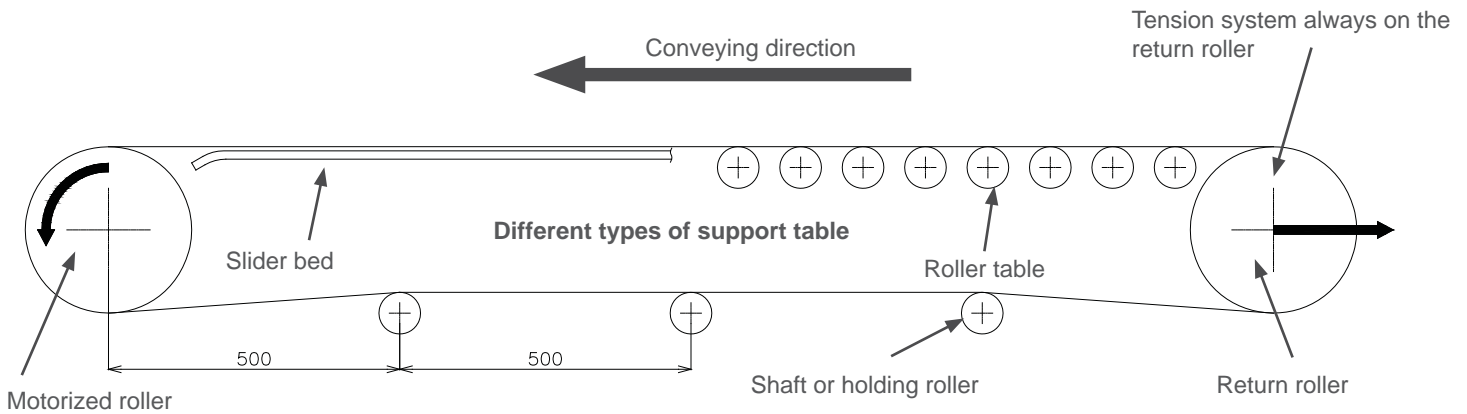

- Belt thickness recommended  $\leq 1\text{mm}$

- Belt weight  $\leq 1,4\text{kg/m}^2$

- Belt tension to be applied:  $10\text{N} \leq T \leq 200\text{N}$

$$T = (\text{Weight of total load on the conveyor} + \text{Weight of belt}) \times \mu \times 1,25 \times 9,81$$

$\mu$  = Coefficient of friction between support table and belt ( $0,2 \leq \mu \leq 0,5$ )

- Conveyor max dimensions :

- Length (L)  $\leq 2000\text{mm}$  (depending on speed code)

- Width (W)  $\leq 800\text{mm}$  (depending on speed code)

- Mount the motorized roller downstream of the conveying direction and the return roller upstream.

### Structure

To resist to the belt tension, reinforced endcaps, with two precision ball bearings are mounted on the roller.

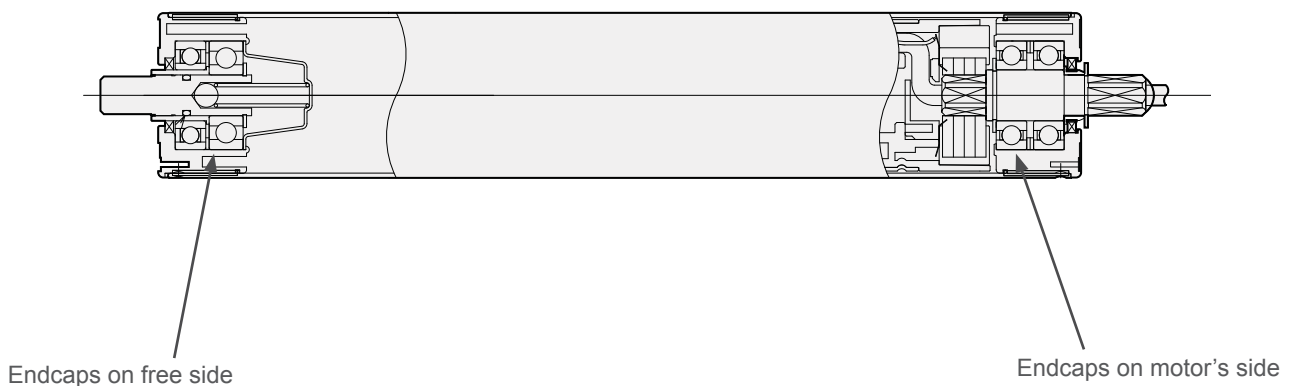



## Transfer capacity

### SPEED CODE 15

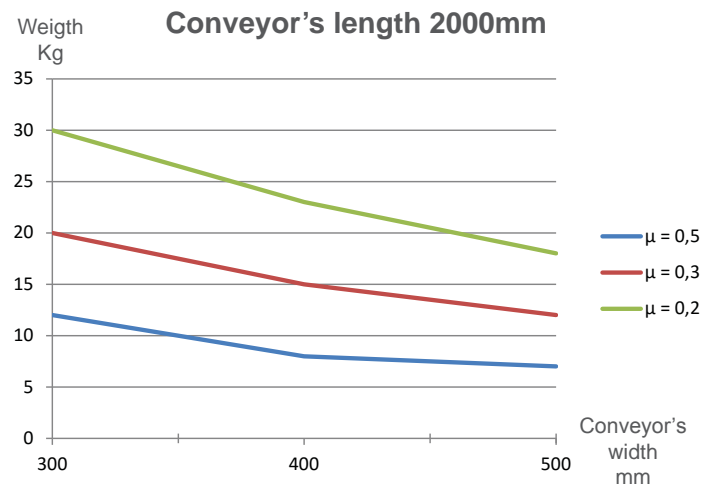
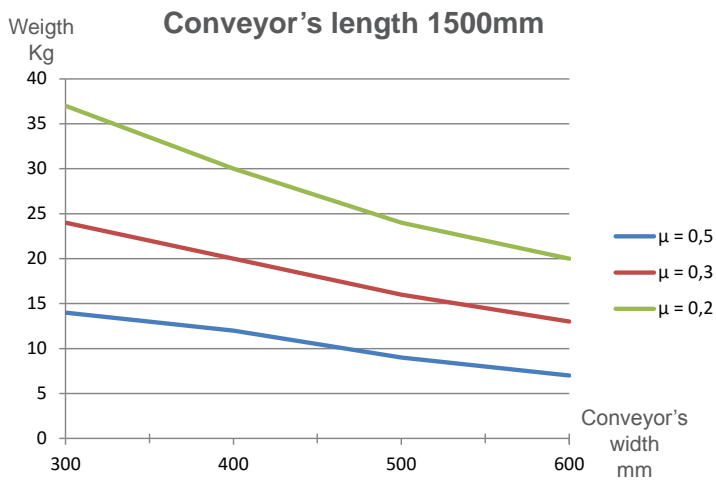
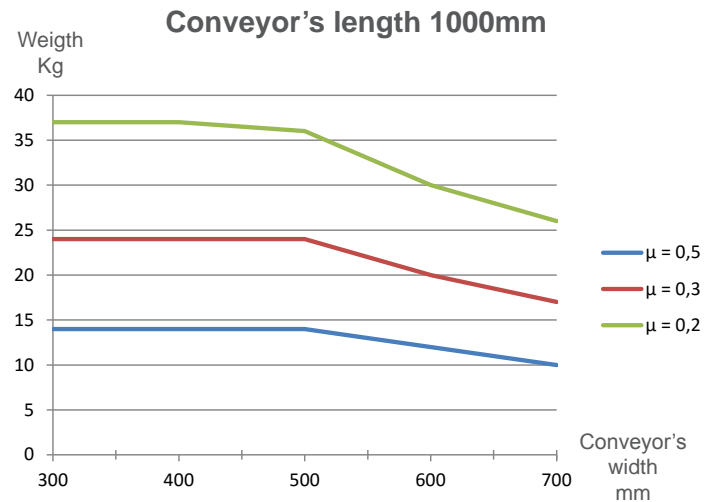
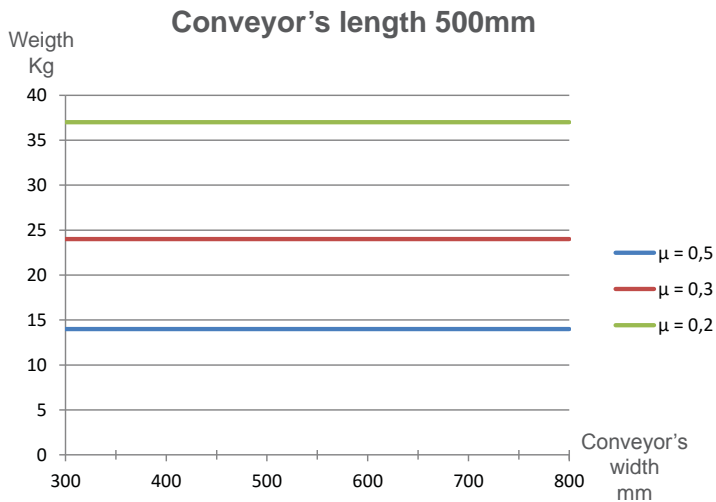

#### • Operation:

- Intermittent : Minimum duty cycle= 2s ON / 2s OFF  
 $ED = ON/(ON+OFF) \leq 50\%$   
 900 starts/H max

- Continuous: 100%

#### • Belt performance : 70%

*These curves are given as a guide. Transfer capacity depends on the nature and quality of the transported load, the belt tension, the quality of the bearings, the nature of the sleeves, the ambient temperature...*

## SPEED CODE 25

### Conveyor's length 500mm

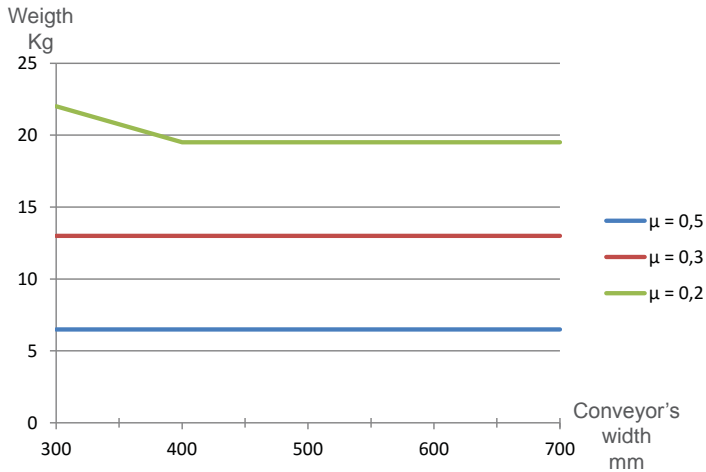

### Conveyor's length 1000mm

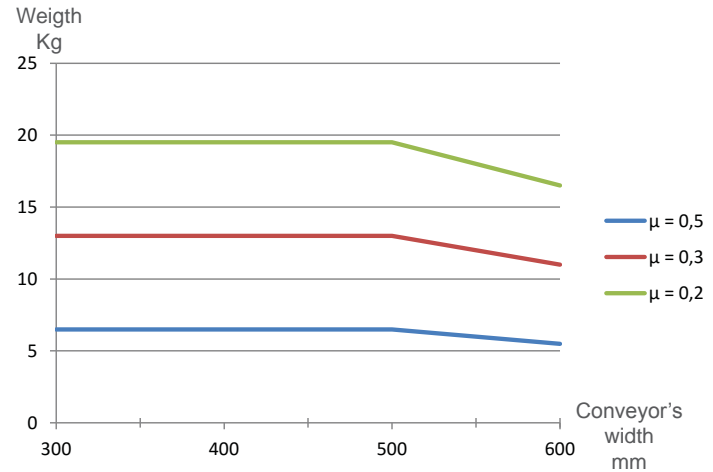

### Conveyor's length 1500mm

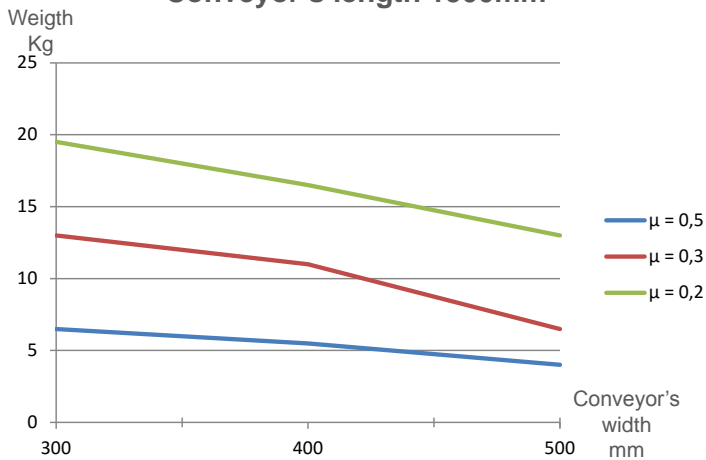

### Conveyor's length 2000mm

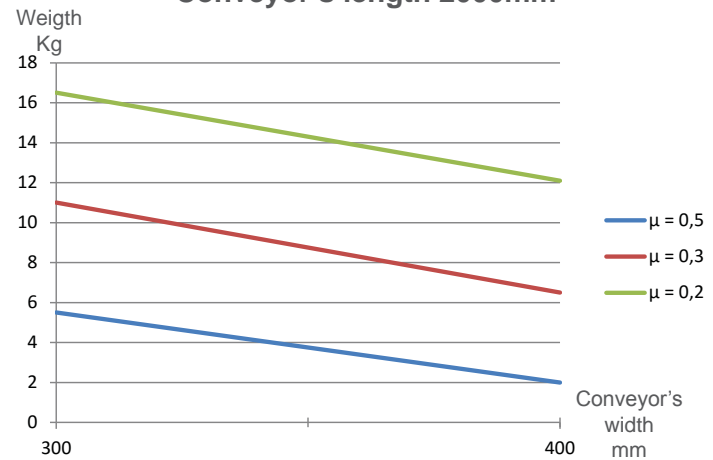

• Operation:

- Intermittent : Minimum duty cycle= 2s ON / 2s OFF  
ED = ON/(ON+OFF) ≤ 50%  
900 starts/H max
- Continuous: 100%

• Belt performance : 70%

*These curves are given as a guide. Transfer capacity depends on the nature and quality of the transported load, the belt tension, the quality of the bearings, the nature of the sleeves, the ambient temperature...*

## SPEED CODE 55

### Conveyor's length 500mm

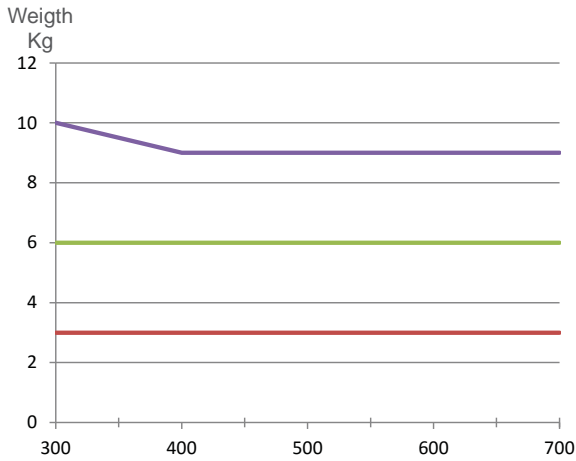

### Conveyor's length 1000mm

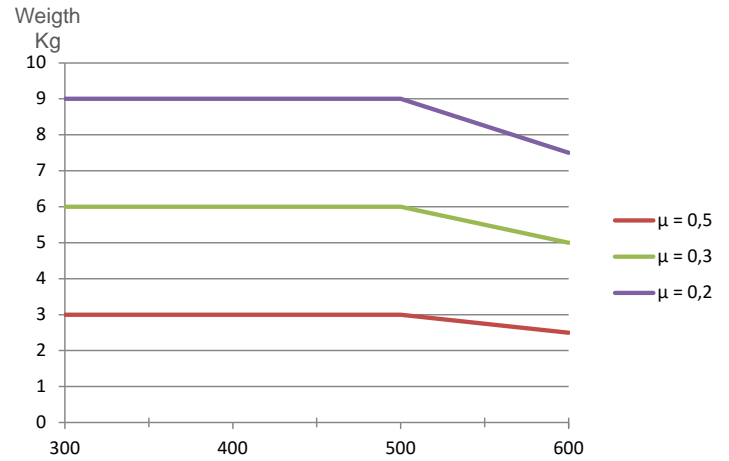

### Conveyor's length 1500mm

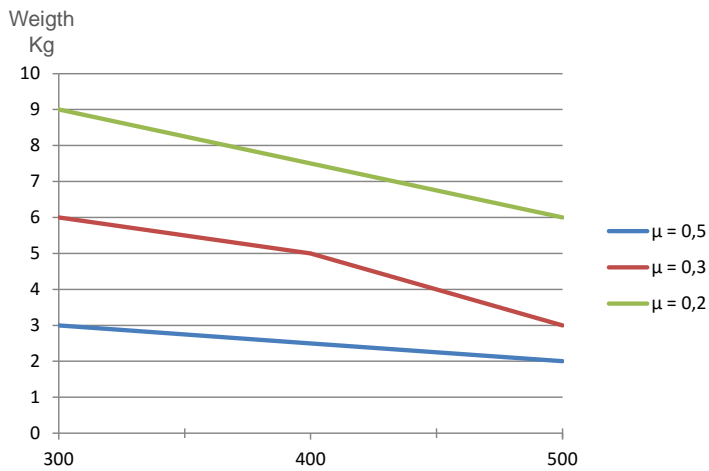

### Conveyor's length 2000mm

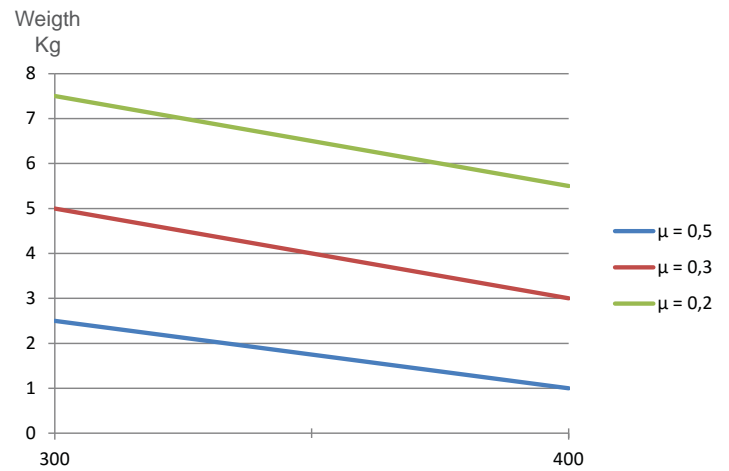

#### • Operation:

- Intermittent : Minimum duty cycle= 2s ON / 2s OFF  
ED = ON/(ON+OFF) ≤ 50%  
900 starts/H max
- Continuous: 100%

#### • Belt performance : 70%

*These curves are given as a guide. Transfer capacity depends on the nature and quality of the transported load, the belt tension, the quality of the bearings, the nature of the sleeves, the ambient temperature...*

## Dimensional characteristics and weight

### Hexagonal plain shaft on motor side and hexagonal shaft with spring on free end

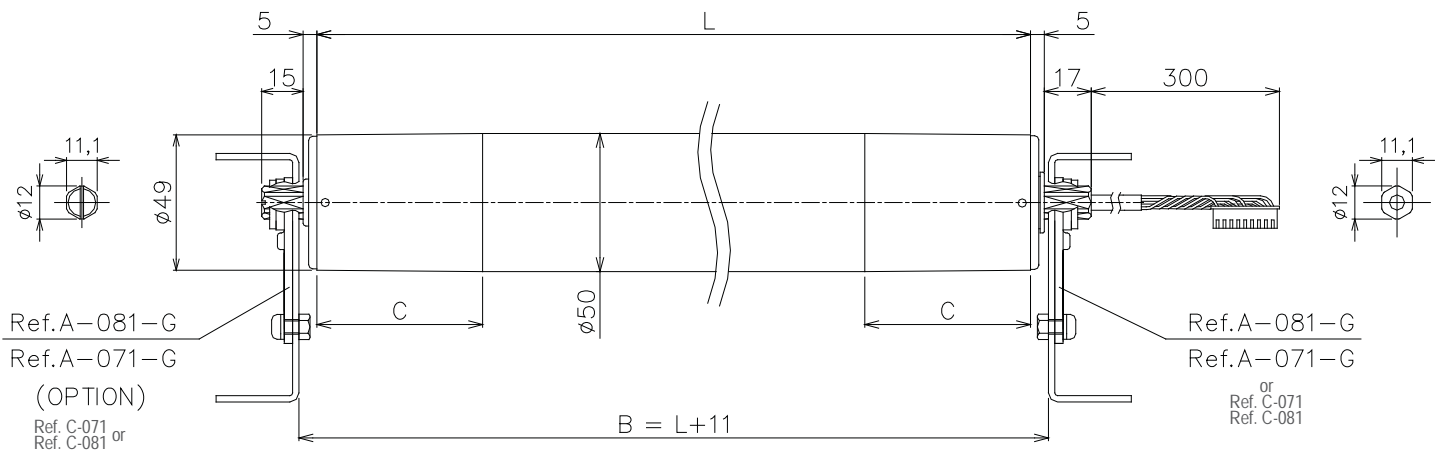

Speed code	Dimension (B)	Tube length (L)
	mini ≤ B ≤ max	mini ≤ L ≤ max
15	376 ≤ B ≤ 811	365 ≤ L ≤ 800
25 / 55	351 ≤ B ≤ 811	240 ≤ L ≤ 800

### Hexagonal plain shaft on motor side and hexagonal shaft fixed on free end

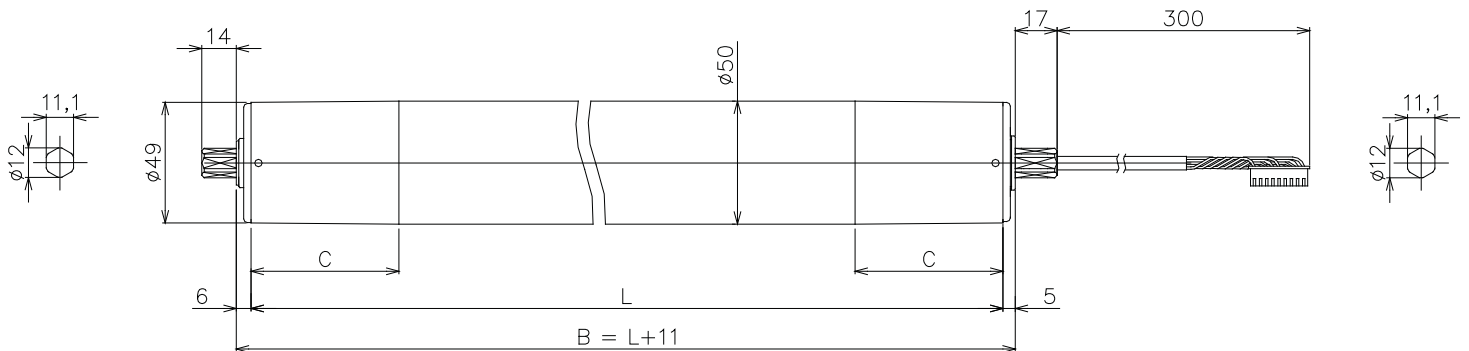

Speed code	Dimension (B)	Tube length (L)
	mini ≤ B ≤ max	mini ≤ L ≤ max
15	356 ≤ B ≤ 811	345 ≤ L ≤ 800
25 / 55	336 ≤ B ≤ 811	325 ≤ L ≤ 800

### WEIGHT / STATIC LOAD / AXIAL FORCE

Tube length		300	400	500	600	700	800
Weigth (Kg)	15 m/min	2,7	2,9	3,0	3,2	3,4	3,5
	25 m/min	2,5	2,7	2,8	3,0	3,2	3,3
	55 m/min	2,5	2,7	2,9	3,0	3,2	3,4
Static max load (kg)		65	55	45	35	30	25
Axial force max (N)		290					

## Tube specification

Various machining, coating and sleeves are available to insure a proper centering and a good adherence.

### Tube machined crowned, zinc coated or stainless steel

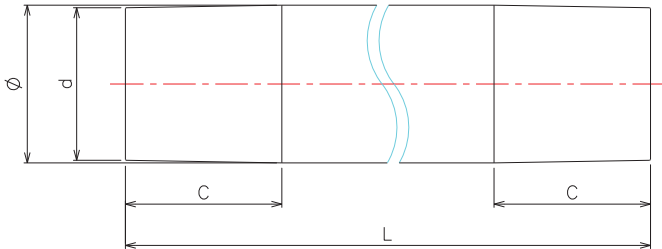

L (mm)	C (mm)	$\varnothing$ (mm)	d (mm)
$\leq 600$	60	50	49
$601 \leq 800$	100		

### Tube machined crowned with natural rubber coating / polyurethane, in steel or stainless steel. 3mm Thickness

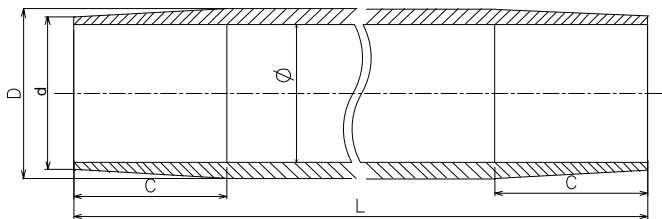

L (mm)	C (mm)	$\varnothing$ (mm)	d (mm)	D (mm)
$\leq 600$	60	50	55	56
$601 \leq 800$	100			

### Tube with centering sleeve, zinc coated or stainless steel.

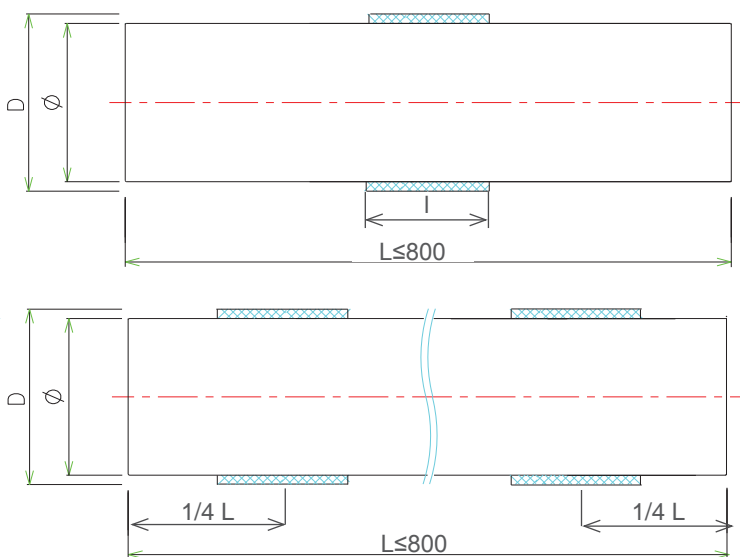

Thickness (mm)	L (mm)	$\varnothing$ (mm)	D (mm)	l (mm)
1	$\leq 800$	50	52	50

## 8 - MOUNTING ON THE FRAMES

### Mounting plate for plain 11.1 mm hexagonal shaft - FLAT ON TOP

Conveyor with hole  $\varnothing 12,1\text{mm}$



or hexagonal 11,2mm

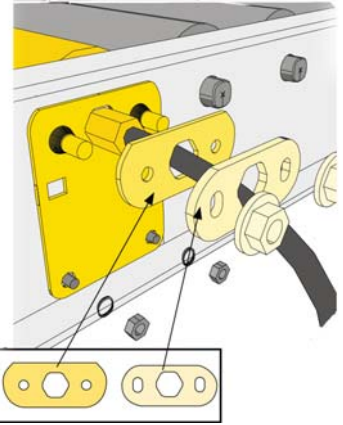

Reference	Plate
	A-071-G

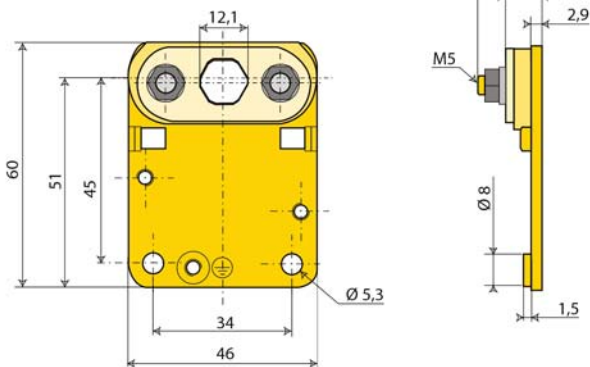

Reference	Plate
	C-071

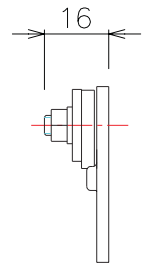
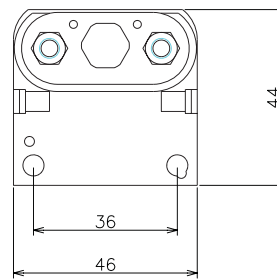

### Mounting plate for plain 11.1 mm hexagonal shaft - ANGLE ON TOP

Conveyor with hole  $\varnothing 12,1\text{mm}$



or hexagonal 11,2mm

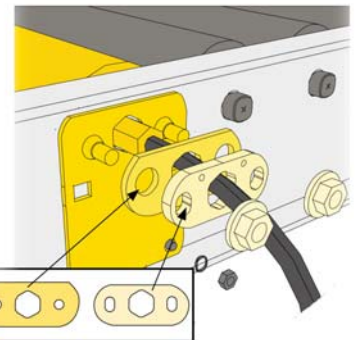

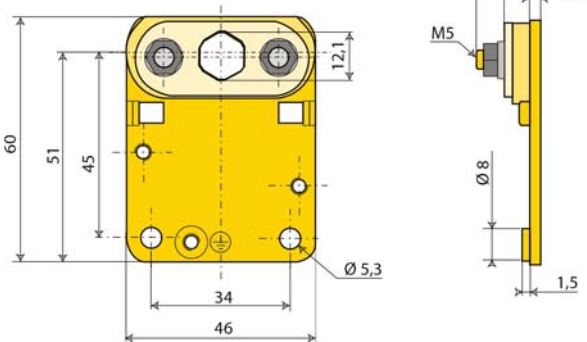

Reference	Plate
	A-081-G

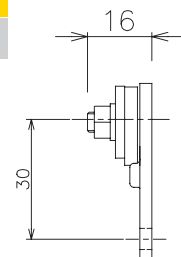
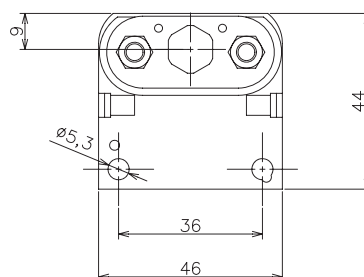

Reference	Plate
	C-081



### Mounting plate for threaded hexagonal shaft - FLAT ON TOP

Conveyor with hole  $\varnothing 12,1\text{mm}$   or hexagonal 11,2mm 

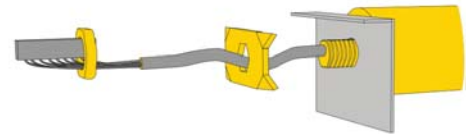
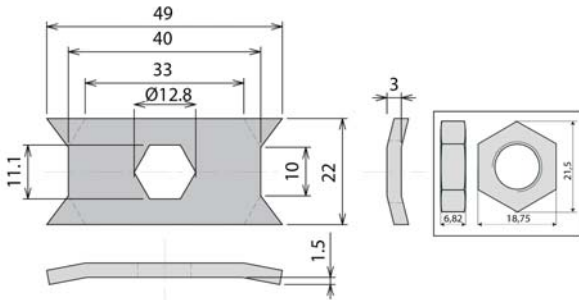

	Claw plate	Nut
Reference	P-0B1	FEY-01

### Mounting plate for threaded hexagonal shaft - ANGLE ON TOP

Conveyor with hole  $\varnothing 12,1\text{mm}$   or hexagonal 11,2mm 

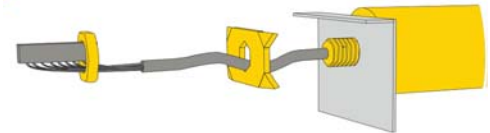
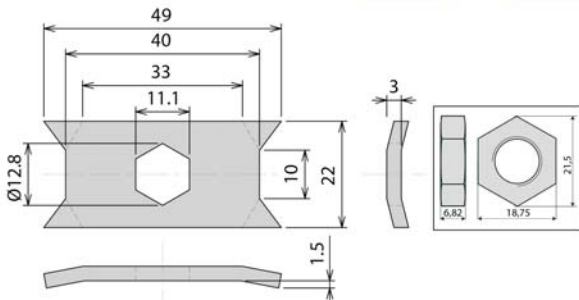

	Claw plate	Nut
Reference	P-0C1	FEY-01

### M8 threaded fixed shaft

Conveyor with holes  $\varnothing 8,4\text{mm}$

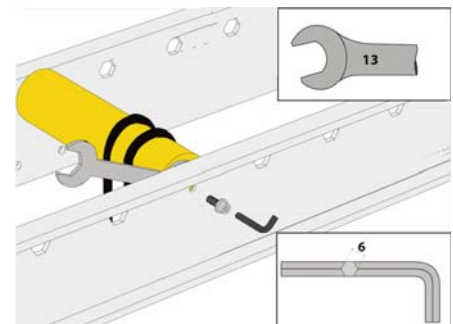

	Bolt
Reference	SP-M8-14

▶ 9 - WIRING

■ With CB016BP circuit board

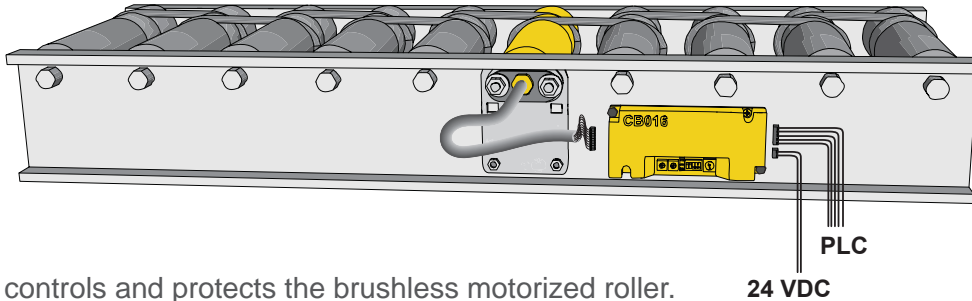

The circuit board controls and protects the brushless motorized roller.

■ With HB510BP circuit board

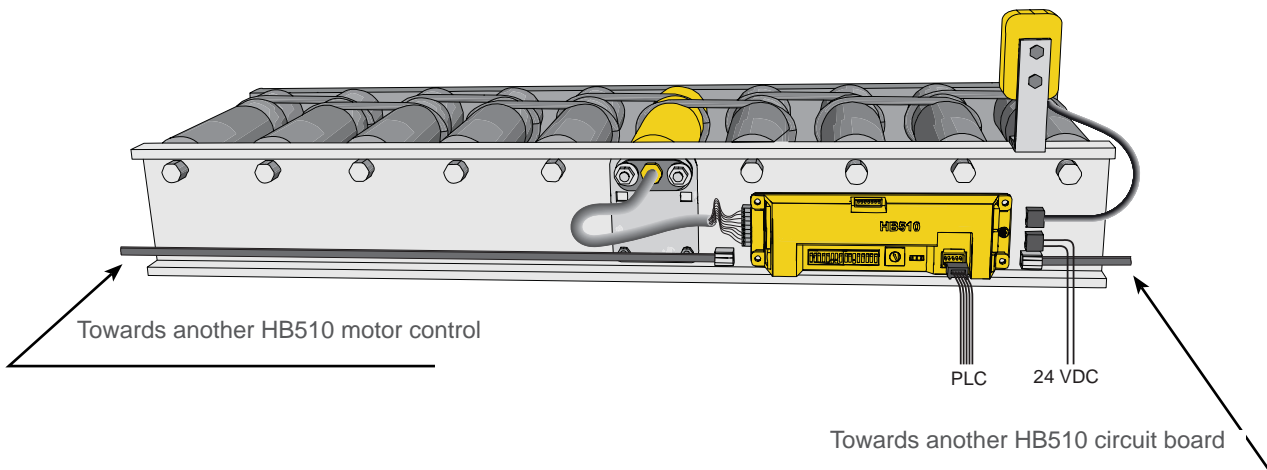

The circuit board controls the motorized roller and manages the zones to ensure ZPA (zero pressure accumulation)

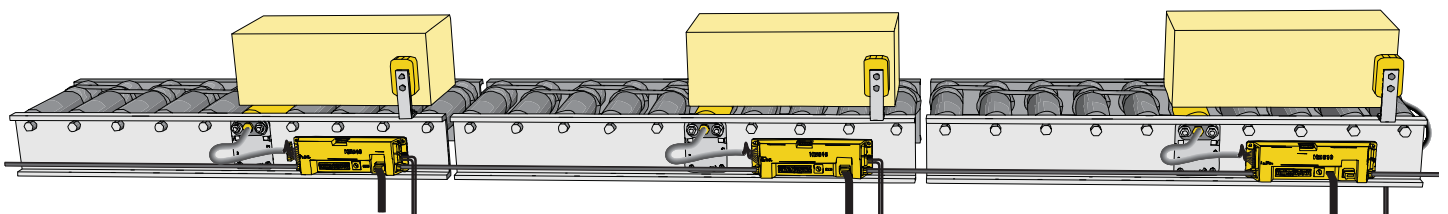



# 10 - ACCESSORIES

## Ribbed belt

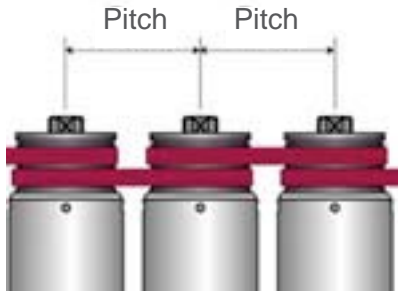

Pitch between the rollers (mm) For pulley Ø43mm	Number of teeth		
	2	3	4
	Load to be conveyed ≤50 Kg	Load to be conveyed ≤300 Kg	Load to be conveyed ≤400 Kg
53-56	Ref. 2PJ246-43	Ref. 3PJ246-43	Ref. 4PJ246-43
60-63	Ref. 2PJ256-43	Ref. 3PJ256-43	Ref. 4PJ256-43
64-65	Ref. 2PJ265-43	Ref. 3PJ265-43	Ref. 4PJ265-43
66-67	Ref. 2PJ270-43	Ref. 3PJ270-43	Ref. 4PJ270-43
71-72	Ref. 2PJ282-43	Ref. 3PJ282-43	Ref. 4PJ282-43
73-75	Ref. 2PJ286-43	Ref. 3PJ286-43	Ref. 4PJ286-43
76-77	Ref. 2PJ290-43	Ref. 3PJ290-43	Ref. 4PJ290-43
78-79	Ref. 2PJ288-43	Ref. 3PJ288-43	Ref. 4PJ288-43
80-84	Ref. 2PJ302-43	Ref. 3PJ302-43	Ref. 4PJ302-43
87-91	Ref. 2PJ314-43	Ref. 3PJ314-43	Ref. 4PJ314-43
92-95	Ref. 2PJ316-43	Ref. 3PJ316-43	Ref. 4PJ316-43
97-101	Ref. 2PJ336-43	Ref. 3PJ336-43	Ref. 4PJ336-43
103-107	Ref. 2PJ346-43	Ref. 3PJ346-43	Ref. 4PJ346-43
115-118	Ref. 2PJ372-43	Ref. 3PJ372-43	Ref. 4PJ372-43
119-121	Ref. 2PJ376-43	Ref. 3PJ376-43	Ref. 4PJ376-43
123-128	Ref. 2PJ388-43	Ref. 3PJ388-43	Ref. 4PJ388-43
129-134	Ref. 2PJ416-43	Ref. 3PJ416-43	Ref. 4PJ416-43
142-147	Ref. 2PJ435-43	Ref. 3PJ435-43	Ref. 4PJ435-43
150-156	Ref. 2PJ442-43	Ref. 3PJ442-43	Ref. 4PJ442-43
157-161	Ref. 2PJ456-43	Ref. 3PJ456-43	Ref. 4PJ456-43
170-176	Ref. 2PJ486-43	Ref. 3PJ486-43	Ref. 4PJ486-43
196-202	Ref. 2PJ536-43	Ref. 3PJ536-43	Ref. 4PJ536-43
208-215	Ref. 2PJ570-43	Ref. 3PJ570-43	Ref. 4PJ570-43
254-258	Ref. 2PJ636-43	Ref. 3PJ636-43	Ref. 4PJ636-43
305-310	Ref. 2PJ746-43	Ref. 3PJ746-43	Ref. 4PJ746-43

## Extension cables

For PM500FE and CB016BP / HB510BP - Male / Female - 10 pins

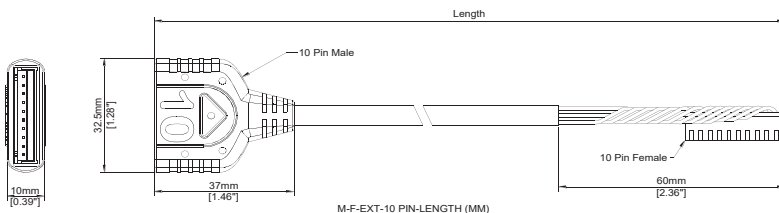

Lenght	Part number of the extension cable
1200mm	ACE-CBM-A1200
2700mm	ACE-CBM-A2700

**Rounded belts**

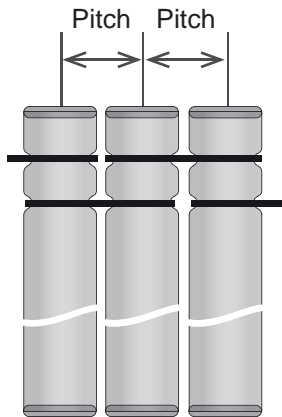

Pitch between the rollers	Belt reference
75mm	POLYCORD-R5-256
100mm	POLYCORD-R5-302

- Belt diameter : 5mm
- Belt tension : 8%
- Material: Thermoplastic polyurethane (TPU)

For grooves with an inner diameter of 38.4 mm

**24 VDC power supply**



Reference	Input	Output	Power	Start-up boost
CT-10-241	380~480V 3 ph	24V-10A	240W	120%
QT-20-241		24V-20A	480W	150%
QT-40-241		24V-40A	960W	150%

- Very weak inrush current.
- Accepts excess current of 120 to 150% at startup (according to model)

**24 VDC distribution connector**

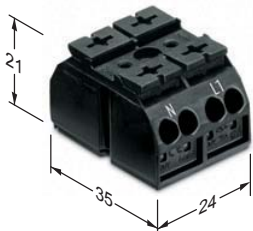

- 32A max
- 2 poles with markings «24V / OV»
- 4 connectors per pole
- Cable 0.5 - 4.00mm (AWG.....)
- Fixed with M3 bolt or screw

Reference	Connector
	PD-2P

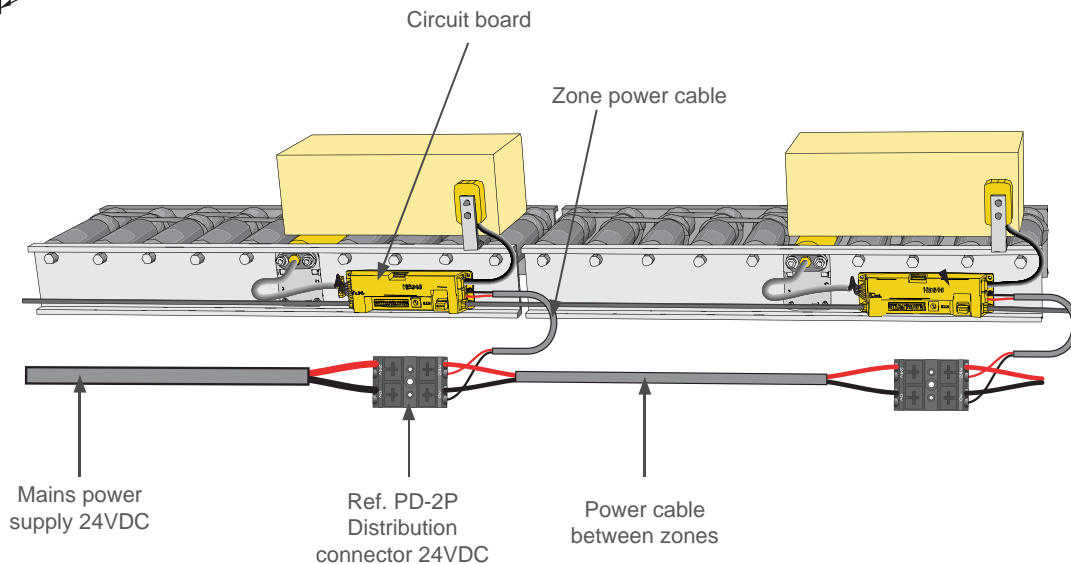

# 11 - PRODUCT IDENTIFICATION

## Round label

Power Moller® rollers come with a round label affixed to the endcaps at the motor end. The following information are shown on the label :

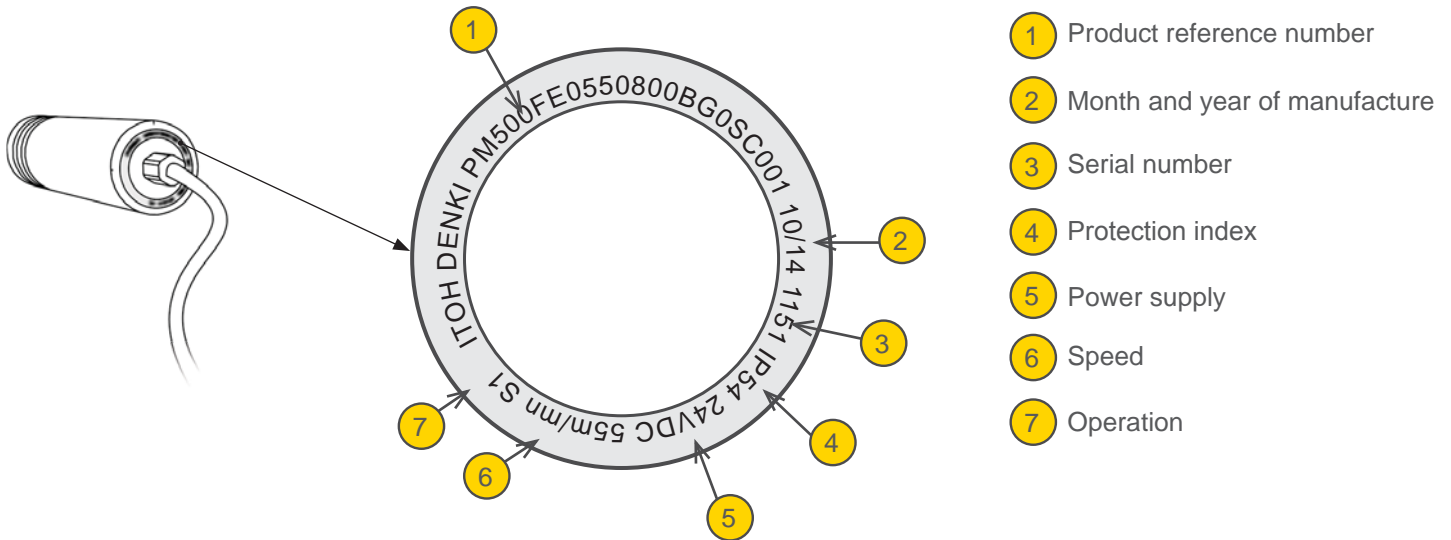

## Square label

Power Moller® rollers come with a square self-adhesive label that must be affixed to the conveyor, to facilitate any future maintenance. The following information are shown on the label :

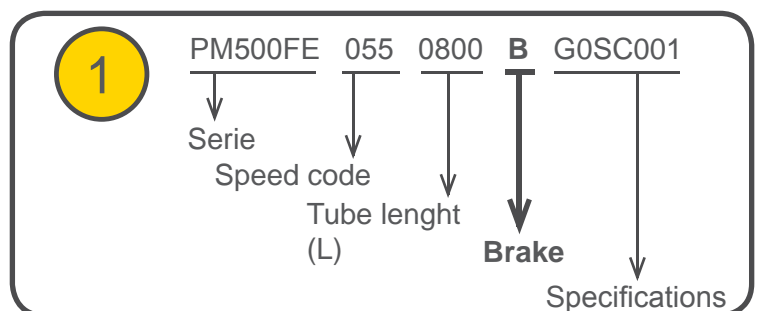
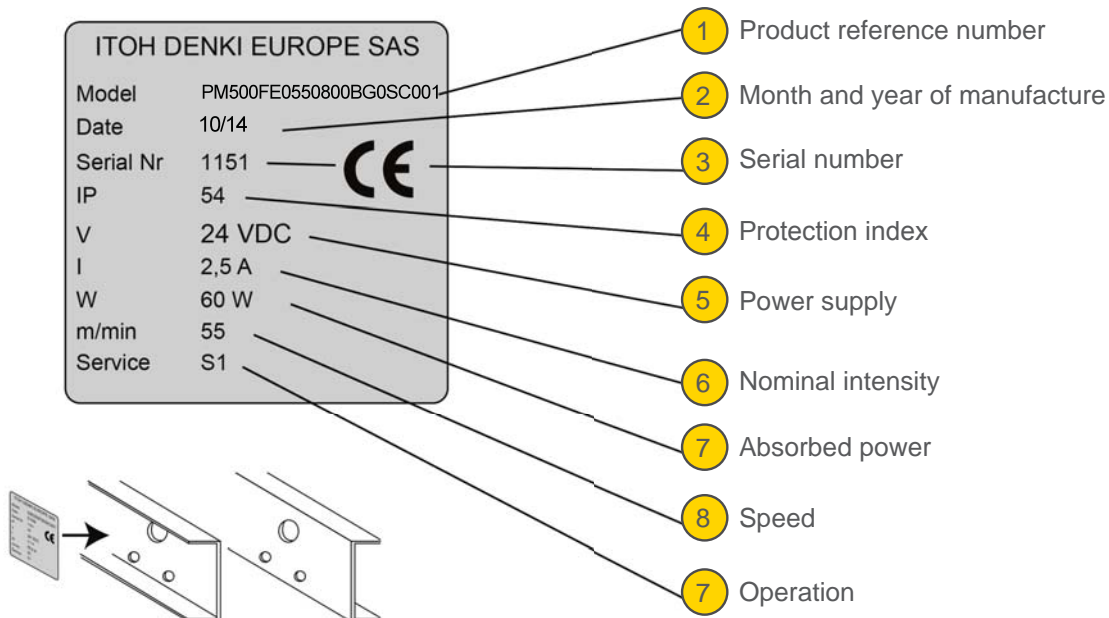



### Operation

- Standard (controlled by a PLC, no accumulation with pressure)
- Accumulation without pressure (ZPA) with our HB510 circuit board
- Accumulation with pressure (Warning: contact our technical service department for approval)
- Other.....

### Environment

- Humidity  Yes ( $\geq 90\%$ )  No (standard case,  $< 90\%$ )
- Projection of liquid  Yes. What liquid :.....  No
- Dust  Yes  No (standard case)
- Temperature  Between  $0^{\circ}\text{C}$  et  $40^{\circ}\text{C}$   Cold room.  $T^{\circ} = \dots\dots\dots$   Other  $T^{\circ} : \dots\dots\dots$
- Other.....

### Motorized roller

- Serie :  Standard without mechanical brake  With mechanical brake
- Protection :  IP54  IP65  Other.....
- Speed code :  15m/min  25m/min  55m/min  90m/min  Other.....
- Tube :  Zinc-coated steel  Stainless steel  Other.....
- Coating :  Without  PVC sleeve 3mm  PVC sleeve 2mm  
 PU  Natural rubber  Other :.....  
 Tapered sleeve  
 Ri 800mm  
 Ri 850mm  
 Other :.....
- Drive :  Direct (no transmission)  
 By ribbed belt  
 By rounded belt  
 Grooves on tube : G0.....mm G1.....mm G2.....mm  
 Pulley for round belt
- Cable :  Standard length (300mm)  Other.....

**INCORPORATION DECLARATION**

**in accordance with the EC Machinery Directive 2006/42/EC, Annex II B**

**The manufacturer:**

ITOH DENKI CO., Ltd  
1146-2 Asazuma-Cho, Kasai, Hyogo 679-0180 Japan

**Distributed in Europe by :**

ITOH DENKI Europe SAS  
490 avenue des Jourdiés - ZAE les Jourdiés - BP 323  
74807 St Pierre en Faucigny Cedex - France

**hereby declares that the product series :**

**PM500FE-B** MOTORIZED ROLLER

**is an incomplete machine as defined in the EC Machinery Directive and therefore does not fully meet the requirements of this Directive. Commissioning is prohibited until the whole machine/system in which it is incorporated is declared to be in compliance with the EC Machinery Directive**

The health and safety requirements of Annex I have been applied. The special technical documents in accordance with Annex VII have been drawn up (and, if appropriate, submitted to the competent authorities).

**Person authorized to compile the technical documentation :**

ITOH DENKI CO., Ltd  
Toshiyuki TACHIBANA  
1146-2 Asazuma-Cho, Kasai, Hyogo 679-0180 Japan

**EC Directives applied :**

- Machinery Directive 2006/42/EC
- European EMC Directive 2004/108/EC
- European RoHS Directive 2011/65/EU

Saint Pierre en Faucigny, 20 November 2013

K. TAMURA, Managing Director





## **ITOH DENKI EUROPE S.A.S.**

490 Av. des Jourdiés  
Z.A.E. les Jourdiés  
74800 St Pierre en Faucigny - France  
Tél. : +33 (0)4 50 03 09 99  
Fax : +33 (0)4 50 03 07 60  
E-mail : [info@itoh-denki.com](mailto:info@itoh-denki.com)

## **SUCCURSALE ITOH DENKI ANGLETERRE**

Suite 1 Trinity Space Centre  
Waldorf Way  
Wakefield WF2 8DH - UK  
Tel : +44 (0)1924 366 539  
Fax : +33 (0)4 50 03 07 60  
E-mail : [info@itoh-denki.com](mailto:info@itoh-denki.com)

## **SUCCURSALE ITOH DENKI ALLEMAGNE**

Neumeyerstrabe 48  
90411 NÜRNBERG - Deutschland  
Tel : +49 911 25 26 - 200  
Fax : +49 911 25 26 - 201  
E-mail : [info@itoh-denki.de](mailto:info@itoh-denki.de)