

EXHPSD STATIC DISCHARGERS

EX - HPSD static dischargers are among the most powerful anti-static tools available. Now they have been ATEX certified - and so are available for use in hazardous areas.

Unrivalled cost-effectiveness in hazardous areas. The low cost does not mean low performance.

- > High Performance without compromise.
- > Particularly effective on high speeds and high charges.
- > Non-contact application. The fibres do not need to touch the material - they should be at a distance of about 2.5mm.
- > Solvent resistant construction - allowing them to resist aggressive chemicals and even to be washed in the solvent, to remove ink, coating and other contaminants.
- > Used by coaters, gravure printers and laminators worldwide.



Specification

Length:	Model 101- Any length up to 4m. Model 201- Any length up to 3m.
Construction:	Model 101- 2mm extruded aluminium walls with "h" body. Model 201- compact 9.5mm x 9.5mm aluminium body.
Fibres:	Carbon Fibre: 6/7 μ diameter. Density of 60,000 filaments/cm. Available with 18mm, 30mm or 50mm fibre.
Fixing:	Model 101- Fixing holes can be drilled in the single wall upright of the "h" body. The M4 x 10 earthing stud is 10mm from one end. Model 201- The M4 fixing studs are 10mm from each end and also in the middle for lengths above 1m.

How it works:

Positioned about 2.5mm from the web, the carbon fibre filaments concentrate the electric field of the static charge and ionise the gap.

This ionised air allows the exchange of ions which neutralises the charge.

The electric field from the static charge in the material is concentrated to ionise the air in the gap between the fibres and the material. This produces ions of the opposite polarity to neutralise the static charge. Unused ions travel to earth through the brush body.

Dimensions:

Model EX-HPSD 101

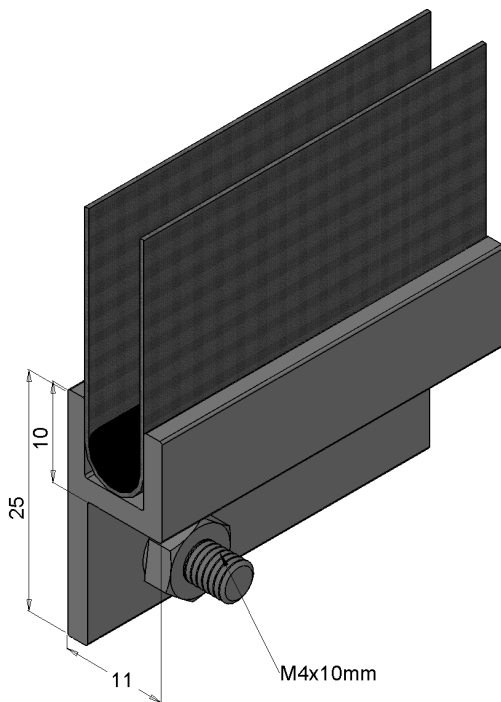

Model EX-HPSD 201

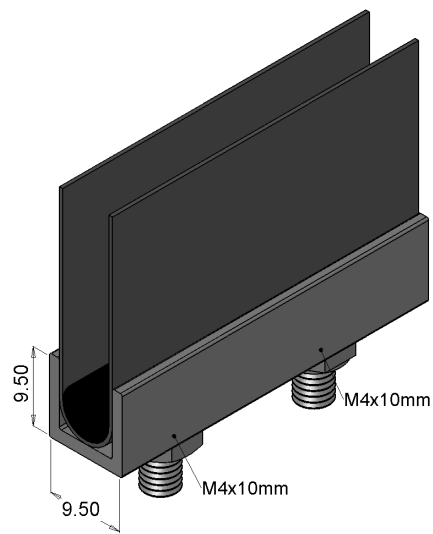

EX Approval

EX Anti-Static Brushes have been certified for use in hazardous area.
Baseefa06ATEX0318 II 2GD

