

High holding forces – electric drive: The electric Clamping Element LCE

The LCE is a refinement of the MKE series.*

In contrast to the MKE, the LCE has a recessed connector. This makes it more compact than the MKE, allowing a direct replacement. The clamping force is generated in the conventional manner via a wedge gear.

The LCE is set apart by a floating mounting, which inhibits transverse forces in the connection arrangement.

Thanks to the improved functional principle, the LCE series achieves very high operating cycles and faster cycle times than the MKE series.

The electronic assembly comprises two parts – the part integrated into the clamping element and the electronic mechanism.

The current is electronically monitored to systematically achieve the required clamping force.

The self-inhibiting functional principle allows currentless and voltage-free clamping, i. e. in the unclamped or clamped state, only the control voltage is present.

* MKE the previous series of the LCE

LCE Series

Base modul

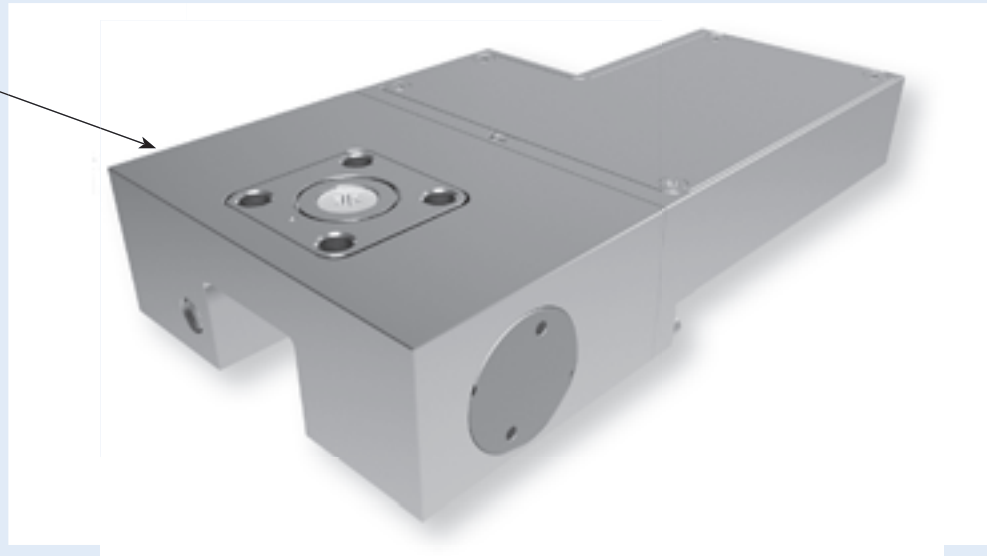

Technical data for LCE series:

Rail size	15–35
Holding forces	550 N–2,000 N
Spring-loaded energy storage	-
PLUS connection	-
Clamping cycles	5 mil. (B10d - value)
Braking cycles	unsuitable
Safety category	IP 65

Application scenarios for LCE:

- Axes with electric positioning
- Table traverses in medical applications
- Positioning of lifting devices
- Electric clamping of machine tables

Connection options for LCE:

The LCE is supplied with an external controller and an 8-pole patch cord, available as an accessory. Please state when ordering!

External electronic components for LCE series:

Supply voltage	24V DC
Power consumption	Switch-on current depends on size, see datasheet
Fuse	Electronic component group fitted with separate fuse
Dimensions	L=100 mm, B=22,5 mm, T=115 mm
Mounting	Can be clipped on rail section
Control inputs	Direction (open/closed) 24 V DC
Control outputs	Pos. 0 (open) PNP 24 V, 500 mA resistance to short circuit Pos. 1 (closed) PNP 24 V, 500 mA resistance to short circuit
Connection lead	Plug 12x1, plug on clamping side, patch cord, 8-pole, sheathed (available as accessory) or clamping with clamp arrangement (3 m).
Plan of terminal connections	See www.zimmer-gmbh.com

Adapting plate accessory for LCE:

Depending on the height of the carriage (measure D), an additional adapting plate is required (see table from page 128).

Accessory patch cord for LCE:

8-pin patch cord with screw-connection (M12x1 **straight** or **90° angle**) and tinned cables (highly-flexible, oil resistant)

Item number patch cord:

CSTE00-10	straight	10 m
CSTE90-10	90° angle	10 m



Type of rail	Size	Type of carriage	Item number	Adapting plate (for height compensation)	Measure D [mm]	Measure D [mm] *1 (page 130)
SR / SSR	15	SR..W, SR..WM, SR..V, SR..VM, SR..TB, SR..TBM, SR..SB, SR..SBM, SSR..XW, SSR..XWM, SSR..XV, SSR..XVM, SSR..XTB	LCE 1501 AS1		24	1
	20	SR..W, SR..WM, SR..V, SR..VM, SR..TB, SR..TBM, SR..SB, SR..SBM, SSR..XW, SSR..XWM, SSR..XV, SSR..XVM, SSR..XTB	LCE 2001 AS1		28	2
	25	SR..W, SR..WM, SR..V, SR..VM, SR..TB, SR..TBM, SR..SB, SR..SBM, SSR..XW, SSR..XWM, SSR..XV, SSR..XVM, SSR..XTB	LCE 2501 AS1	PMK 25-2	33	3
	30	SR..W, SR..WM, SR..V, SR..VM, SR..TB, SR..TBM, SR..SB, SR..SBM, SSR..XW, SSR..XWM	LCE 3001 AS1		42	9
	35	SR..W, SR..WM, SR..V, SR..VM, SR..TB, SR..TBM, SR..SB, SR..SBM, SSR..XW	Ⓞ		48	Ⓞ
HSR	15	HSR..A, HSR..AM, HSR..B, HSR..BM, HSR..C HSR..R, HSR..RM, HSR..YR, HSR..YRM	LCE 1501 AS1 LCE 1501 AS1		24 28	1
	20	HSR..A, HSR..AM, HSR..LA, HSR..LAM, HSR..B, HSR..BM, HSR..LB, HSR..LBM, HSR..C, HSR..R, HSR..RM, HSR..LR, HSR..LRM, HSR..YR, HSR..YRM, HSR..CA, HSR..CAM, HSR..HA, HSR..HAM, HSR..CB, HSR..CBM, HSR..HB, HSR..HBM	LCE 2001 AS1	PMK 20-2	30	2
	25	HSR..A, HSR..AM, HSR..LA, HSR..LAM, HSR..B, HSR..BM, HSR..LB, HSR..LBM, HSR..C, HSR..CA, HSR..CAM, HSR..HA, HSR..HAM, HSR..CB, HSR..CBM, HSR..HB, HSR..HBM	LCE 2501 AS1	PMK 25-2	36	5
		HSR..R, HSR..RM, HSR..LR, HSR..LRM, HSR..YR, HSR..YRM	LCE 2501 AS1	PMK 25-6	40	
	30	HSR..A, HSR..AM, HSR..LA, HSR..LAM, HSR..B, HSR..BM, HSR..LB, HSR..LBM, HSR..C, HSR..CA, HSR..CAM, HSR..HA, HSR..HAM, HSR..CB, HSR..CBM, HSR..HB, HSR..HBM	LCE 3001 AS1		42	9
		HSR..R, HSR..RM, HSR..LR, HSR..LRM, HSR..YR, HSR..YRM	LCE 3001 AS1	PMK 30-3	45	
	35	HSR..A, HSR..AM, HSR..LA, HSR..LAM, HSR..B, HSR..BM, HSR..LB, HSR..LBM, HSR..C, HSR..CA, HSR..CAM, HSR..HA, HSR..HAM, HSR..CB, HSR..CBM, HSR..HB, HSR..HBM	Ⓞ		48	Ⓞ
		HSR..R, HSR..RM, HSR..LR, HSR..LRM, HSR..YR, HSR..YRM	Ⓞ		55	Ⓞ
SHS	15	SHS..C, SHS..LC, SHS..V, SHS..LV	LCE 1501 AS1	PMK 15-2	24	7
		SHS..R	LCE 1501 AS1	PMK 15-6	28	
	20	SHS..C, SHS..LC, SHS..V, SHS..LV	LCE 2001 AS1	PMK 20-2	30	2
		SHS..R, SHS..LR	LCE 2501 AS1	PMK 25-4	36	3
	25	SHS..C, SHS..LC, SHS..V, SHS..LV	LCE 2501 AS1	PMK 25-8	40	
		SHS..R, SHS..LR	LCE 3001 AS1	PMK 30-2	42	10
	35	SHS..C, SHS..LC, SHS..V, SHS..LV	Ⓞ	PMK 30-5	45	
SHS..R, SHS..LR		Ⓞ		48	Ⓞ	
SNR / SNS	25	SNR..R, SNR..LR, SNR..C, SNR..LC, SNS..R, SNS..LR, SNS..C, SNS..LC	Ⓞ		31	Ⓞ
		SNR..R, SNR..LR, SNR..C, SNR..LC, SNS..R, SNS..LR, SNS..C, SNS..LC	LCE 3001 AS1		38	11
	30	SNR..R, SNR..LR, SNR..C, SNR..LC, SNS..R, SNS..LR, SNS..C, SNS..LC	Ⓞ		44	Ⓞ
		SNR..CH, SNR..LCH, SNS..CH, SNS..LCH	Ⓞ		48	Ⓞ
	35	SNR..RH, SNR..LRH, SNS..RH, SNS..LRH	Ⓞ		55	Ⓞ
NR / NRS	25	NR..XR, NR..XLR, NR..XA, NR..XLA, NR..XB, NR..XLB, NRS..XR, NR S..XLR, NRS..XA, NRS..XLA, NRS..XB, NRS..XLB	Ⓞ		31	Ⓞ
		NR..R, NR..LR, NR..A, NR..LA, NR..B, NR..LB, NRS..R, NRS..LR, NRS..A, NRS..LA, NRS..B, NRS..LB	LCE 3001 AS1		38	11
	35	NR..R, NR..LR, NR..A, NR..LA, NR..B, NR..LB, NRS..R, NRS..LR, NRS..A, NRS..LA, NRS..B, NRS..LB	Ⓞ		44	Ⓞ
SRG	15	SRG..A, SRG..V	LCE 1501 ES1		24	1
	20	SRG..A, SRG..LA, SRG..V, SRG..LV	LCE 2001 ES1		30	6
	25	SRG..C, SRG..LC	LCE 2501 ES1		36	4
		SRG..R, SRG..LR	LCE 2501 ES1	PMK 25-4	40	
	30	SRG..C, SRG..LC	LCE 3001 ES1		42	8
		SRG..R, SRG..LR	LCE 3001 ES1	PMK 30-3	45	
	35	SRG..C, SRG..LC	Ⓞ		48	Ⓞ
SRG..R, SRG..LR		Ⓞ		55	Ⓞ	

*1 Supplements the measure table and datasheet

See page 11 for part number explanation

Type of rail	Size	Item number	(for height compensation)	Measure D [mm] ^{*1}	(page 130)	
R1605, R1606, R1607, R1608, R1645, R1647, R2045, R2047	15	R1622, R1623, R1631, R1632, R1651, R1653, R1661, R1662, R1665, R1666, R2001, R2002, R2011, R2012, R2000, R2010	LCE 1505 AS1		24	1
		R1621	LCE 1505 AS1	PMK 15-4	28	
	20	R1622, R1623, R1631, R1632, R1651, R1653, R1661, R1662, R1665, R1666, R2001, R2002, R2011, R2012, R2000, R2010	LCE 2005 AS1		30	6
		R1621, R1624	LCE 2505 AS1	PMK 25-4	40	
	25	R1622, R1623, R1631, R1632, R1651, R1653, R1661, R1662, R1665, R1666, R2001, R2002, R2011, R2012, R2000, R2010	LCE 2505 AS1		36	4
		R1621, R1624	LCE 3005 AS1	PMK 30-3	45	
	30	R1622, R1623, R1631, R1632, R1651, R1653, R1661, R1662, R1665, R1666, R2001, R2002, R2011, R2012, R2000, R2010	LCE 3005 AS1		42	8
		R1621, R1624	LCE 3005 AS1	PMK 30-3	45	
		R1622, R1623, R1631, R1632, R1651, R1653, R1661, R1662, R1665, R1666, R2001, R2002, R2011, R2012, R2000, R2010	⊗		48	⊗
	35	R1621, R1624	⊗		55	
R1805, R1806, R1807, R1808, R1845, R1846, R1847		LCE 2505 BS1		36	4	
R1821, R1824		LCE 2505 BS1	PMK 25-4	40		
35	R1851, R1853	⊗		48	⊗	
	R1821, R1824	⊗		55		

Rail manufacturer
Rexroth
Bosch Group

MRS	25	MRW..A, MRW..B	LCE 2503 AS1		36	4
		MRW..C, MRW..D, MRW..E	LCE 2503 AS1	PMK 25-4	40	
	35	MRW..A, MRW..B	⊗		48	⊗
		MRW..C, MRW..D, MRW..E	⊗		55	
BMS	15	BMW..A, BMW..F, BMW..K	⊗		24	⊗
		BMW..C	⊗		28	
	20	BMW..A, BMW..B, BMW..C, BMW..D	⊗		30	⊗
		BMW..C, BMW..D, BMW..E	⊗		40	
	25	BMW..A, BMW..B, BMW..F, BMW..G	⊗		36	⊗
		BMW..C, BMW..D, BMW..E	⊗		40	
	30	BMW..A, BMW..B, BMW..F, BMW..G	⊗		42	⊗
		BMW..C, BMW..D, BMW..E	⊗		45	
	35	BMW..A, BMW..B, BMW..F, BMW..G	⊗		48	⊗
		BMW..C, BMW..D, BMW..E	⊗		55	

Rail manufacturer
SCHNEEBERGER

LWH	15	LWH..B, LWH..SL, LWH..M, LWHT..B, LWHT..SL, LWHT..M, LWHS..B, LWHS..SL, LWHS..M	⊗		24	⊗
		LWHD..B, LWHD..M, LWHY	⊗		28	
	20	LWH..B, LWH..SL, LWH..M, LWHG, LWHT..B, LWHT..SL, LWHT..M, LWHTG, LWHS..B, LWHS..SL, LWHS..M, LWHSG, LWHY	⊗		30	⊗
		LWH..B, LWH..SL, LWH..M, LWHG, LWHT..B, LWHT..SL, LWHT..M, LWHTG, LWHS..B, LWHS..SL, LWHS..M, LWHSG	⊗		36	⊗
	25	LWHD..B, LWHD..M, LWHDG, LWHY	⊗		40	
		LWH..B, LWH..SL, LWH..M, LWHG, LWHT..B, LWHT..SL, LWHT..M, LWHTG, LWHS..B, LWHS..SL, LWHS..M, LWHSG	⊗		42	⊗
	30	LWHD..B, LWHD..M, LWHDG, LWHY	⊗		45	
		LWH..B, LWH..M, LWHG, LWHT..B, LWHT..M, LWHTG	⊗		48	⊗
	35	LWHD..B, LWHD..M, LWHDG, LWHY	⊗		55	
		MH	MH, MHT, MHS	⊗		24
MHD	⊗			28		
20	MH, MHG, MHT, MHTG, MHS, MHSG		⊗		30	⊗
	MHD, MHDG		⊗		40	
25	MH, MHG, MHT, MHTG, MHS, MHSG		⊗		36	⊗
	MHD, MHDG		⊗		40	
30	MH, MHG, MHT, MHTG, MHS, MHSG		⊗		42	⊗
	MHD, MHDG		⊗		45	
35	MH, MHG, MHT, MHTG		⊗		48	⊗
	MHD, MHDG		⊗		55	

Rail manufacturer
IKO

*1 Supplements the measure table and datasheet

See page 11 for part number explanation

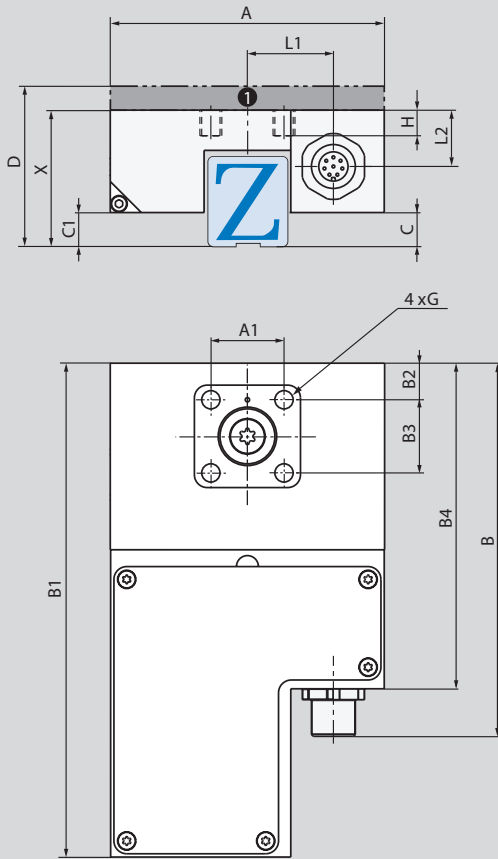

Note: Consider measurement C/Interfering contour!

1 Adapting plate PMK (accessories)

Measure table	Holding power [N] LCE	A [mm]	A1 [mm]	B [mm]	B1 [mm]	B2 [mm]	B3 [mm]	B4 [mm]	C [mm]	C1 [mm]	X [mm]	G [mm]	L1 [mm]	L2 [mm]	H [mm]
1	550	55	15	93	115	8,5	15	80	4,75	2,85	24	M4	17,5	10,7	4,5
2	800	62,8	20	103	115	6	20	90	7,05	4,05	28	M5	21	11	5,5
3	1200	75	20	107	135	10	20	94	4	4	32	M6	23,5	15,4	6
4	1200	75	20	107	135	10	20	94	8	3,5	36	M6	23,5	15,4	6
5	1200	75	20	107	135	10	20	94	6	6	34	M6	23,5	15,4	6
6	800	62,8	20	103	115	6	20	90	9,05	3,05	30	M5	21	11	5,5
7	550	55	15	93	115	8,5	15	80	2,75	0,85	22	M4	17,5	10,7	4,5
8	2000	90	22	110	153,5	9	22	97	10	3,5	42	M8	29	20	8
9	2000	90	22	110	153,5	9	22	97	10	7	42	M8	29	20	8
10	2000	90	22	110	153,5	9	22	97	8	5	40	M8	29	20	8
11	2000	90	22	110	153,5	9	22	97	6	3	38	M8	29	20	8