

Installation Instructions

English

SUSPA ELS3-500S-BTU-Q-HeavyDuty including 2-leg or 4-leg HeavyDuty Subframe



Read installation instructions carefully before initial use!

Follow the safety instructions!

This partly completed machinery is intended to be incorporated into other machinery, other partly completed machinery/equipment or to be joined with another framework so as to form a complete machine as specified under the Machinery Directive. The machine should be put into operation only after a conformity evaluation procedure in accordance with the Machinery Directive has been carried out for the complete machine

No revision service applies to this documentation. The current installation instructions are available at

<https://www.suspa.com/global/downloads/>

September 2018

These installation instructions are a component of the technical documentation of the system in accordance with the EC Machinery Directive.

These installation instructions correspond to the "Directive 2006/42/EC of the European Parliament and the Council for Adjustment of Legal and Administrative Regulations of Member States for Machinery" (Machinery Directive), Appendix I, Item 1.7.4.

These installation instructions are addressed to the person in charge, who must pass it on to the personnel responsible for connection, use, and maintenance of the machine. The person in charge must ensure that the installation instructions and the information contained in the accompanying documents have been read and understood.

These installation instructions must be kept in a well-known and easily accessible location and read in case of any doubt.

The manufacturer is not liable for injuries to people or animals, and damage to objects or to the machine itself arising from the improper/unauthorized use or by ignoring the safety criteria contained in these installation instructions or by modification of the machine or use of unsuitable spare parts.

The copyright for these installation instructions is held solely by



SUSPA GmbH
Eisenhammerstrasse 3
92237 Sulzbach-Rosenberg
GERMANY

or its legal successor.

The contents of the user information is the intellectual property of SUSPA GmbH.

SUSPA GmbH expressly reserves the ownership of and copyright to the data contained in the user information.

Reproduction and duplication, even in excerpts, are permitted only upon the written consent of SUSPA GmbH.

Status: September 2018

1	Information Concerning this Document	5
1.1	Structure of the Warnings	5
1.2	Signal Words and Signal Colors	5
1.3	Symbols	6
1.3.1	Warning Notice	6
2	Identification and Notes	7
2.1	Designation	7
2.2	Manufacturer	9
2.3	Intended Use	10
2.4	Reasonably Foreseeable Misuse	11
2.5	General Instructions	12
2.5.1	Warranty and Liability	12
2.5.2	Objectives of the Installation Instructions	12
2.5.3	Target Audience of the Installation Instructions	13
3	Safety Instructions	15
3.1	Obligations	15
3.1.1	Operating Company's Obligations	16
3.2	Residual Risk	16
3.3	Safety Equipment	16
3.4	Additional Instructions	16
4	Design and Function	17
4.1	Technical Specifications	17
4.2	Design and Function of the Height Adjustment System Including the HeavyDuty Subframes	20
5	Transport	23
5.1	Safety Instructions for Transport	23
5.2	Transportation Procedure	23
6	Installation	24
6.1	Unpacking	24
6.1.1	Disposal of Transport and Warehouse Packaging	24
6.1.2	Checklist of All Components Included in the Delivery	25
6.2	Operating Conditions	27
6.3	Install Components	28
6.3.1	Installation in General	28
6.3.2	Mounting the Lifting Elements Including the HeavyDuty Subframe	30
6.3.2.1	Assembling Lifting Elements Including the 2-Leg HeavyDuty Subframe	32
6.3.2.2	Assembling Lifting Elements Including the 4-Leg HeavyDuty Subframe	39
6.3.3	Mounting the Electrical Controller	46
6.3.4	Mounting the Manual Switch	49
6.3.5	Overall Installation	51
6.3.6	Laying Electric Wires and Cables	52
6.4	Space Requirements	53
6.5	Component Alignment	53

7	Operation.....	55
7.1	Warning Notices for Operation.....	55
7.2	Tests Prior to Switching the Machine On.....	55
7.3	Duty Cycle.....	56
7.4	Manual Switch.....	57
7.4.1	Function of the Manual Switch.....	57
7.4.1.1	Simple Manual Switch UBM-F/2-p.....	57
7.4.1.2	Programmable Manual Switch UBS/6-LCD (Optional).....	58
7.5	Perform Reset.....	59
7.6	Faults and Error Indications.....	59
7.6.1	Fault and Operational Messages.....	60
7.6.1.1	Manual Switch Error Messages.....	60
7.6.1.2	Important Display Codes and their Meanings.....	60
7.6.2	Troubleshooting.....	61
7.6.2.1	Malfunctions in the Cycle Procedure.....	63
8	Service and Maintenance.....	64
8.1	General.....	64
8.2	Instructions for Maintenance.....	65
8.2.1	Cleaning.....	65
8.3	Maintenance.....	65
8.3.1	Changing Load Conditions.....	66
8.3.2	Contamination.....	66
8.3.3	Damages to Electrical Wires.....	66
9	Decommissioning.....	67
9.1	Component Storage.....	67
9.2	Disposal of Components.....	67
10	Appendix.....	68
10.1	Index of Tables.....	68
10.2	Index of Figures.....	69
10.3	Incorporation.....	71

1 Information Concerning this Document

1.1 Structure of the Warnings

The combination of a signal word in conjunction with a pictogram classifies the respective warning. The symbol can vary depending on the type of danger.

⚠ THE WARNING IS GIVEN BELOW A SIGNAL WORD THAT INDICATES THE EXTENT OF THE EXISTING DANGER.

The first line after the signal word describes the type and source of the potential danger.

The following section describes the consequences if no measures are adopted to safeguard against the danger.

The last paragraph describes the measures to avoid the danger.

1.2 Signal Words and Signal Colors

The following signal words are based on DIN EN 82079-1 and ANSI Z 535.4, and are used in this documentation. The safety colors have been adopted from the standard ISO 3864-1.



Signal word	Use	Explanation
 DANGER	Warning	Indicates a dangerous situation, which if ignored, leads to death or severe injuries.
 WARNING	Warning	Indicates a dangerous situation, which, if ignored may lead to injuries and damage to property.
 CAUTION	Warning	Indicates a dangerous situation, which, if ignored may lead to minor injuries and damage to property.
IMPORTANT	Note	Refers to ways to facilitate and simplify operation and cross-references. It excludes the danger of damage to property and the risk of injuries.
SAFETY INSTRUCTION	Safety instruction	Draws attention to specific safety-relevant instructions or procedures.

Table 1 Signal words and signal colors

1.3 Symbols

Some of the following special safety symbols according to DIN EN ISO 7010: 2011 are used in the corresponding sections of these installation instructions and require particular attention depending on the signal word and symbol combination:

Symbol	Use	Explanation
	Note	Important information for understanding the device or for optimized operations.

Table 2 Symbols

1.3.1 Warning Notice





Symbol	Explanation	Symbol	Explanation
	General warning sign		Warning against hazardous electrical voltage
	Warning against risk of hand injuries		Warning of hot surfaces

Table 3 Warning

2 Identification and Notes

2.1 Designation

SUSPA ELS3-500-HeavyDuty Height Adjustment System consisting of

2-leg Height Adjustment System	
2 x	004 102767 ELS3-500S-BTU-Q-S-HD
2 x	098 10015 Adapter DIN (female) to Molex (male) for motor
1 x	Sheet 198 1002A SMS SCT4 controller (including power cord)
1 x	098 10087 manual switch UBM-F02 or 098 10088 manual switch UBS 6 LCD

Table 4 Components SUSPA ELS3-500-HeavyDuty system; 2-leg Height Adjustment System

4-leg Height Adjustment System	
4 x	004 102767 ELS3-500S-BTU-Q-S-HD
4 x	098 10015 Adapter DIN (female) to Molex (male) for motor
1 x	Sheet 198 1002A SMS SCT4 controller (including power cord)
1 x	098 10087 manual switch UBM-F02 or 098 10088 manual switch UBS 6 LCD

Table 5 Components SUSPA ELS3-500-HeavyDuty system; 4-leg Height Adjustment System

HeavyDuty subframe (2-leg) consisting of:

2-leg HeavyDuty subframe		
Subframe length	153 11964 EAT3-HD-1600-002-01-S	
1600 mm	1 x	153 11873 Cross beam set HD 2-leg 160
	1 x	153 11925 Frame set HD 2-leg
	1 x	197 10172 Accessories kit HD 2-leg table
1800 mm	153 11965 EAT3-HD-1800-002-01-S	
	1 x	153 11881 Cross beam set HD 2-leg 180
	1 x	153 11925 Frame set HD 2-leg
	1 x	197 10172 Accessories kit HD 2-leg table
2000 mm	153 11966 EAT3-HD-2000-002-01-S	
	1 x	153 11874 Cross beam set HD 2-leg 200
	1 x	153 11925 Frame set HD 2-leg
	1 x	197 10172 Accessories kit HD 2-leg table
Optional	1 x	197 10174 Connection set HD
Optional	1 x	158 10528 Extension set HD

Table 6 Components of HeavyDuty subframe; 2-leg Height Adjustment System

HeavyDuty subframe (4-leg) consisting of:

4-leg HeavyDuty subframe		
Subframe length	153 11967 EAT3-HD-1600-004-01-S	
1600 mm	1 x	153 11871 Cross beam set HD 4-leg 160
	1 x	153 11926 Frame set HD 4-leg
	1 x	197 10173 Accessories kit HD 4-leg table
1800 mm	153 11968 EAT3-HD-1800-004-01-S	
	1 x	153 11880 Cross beam set HD 4-leg 180
	1 x	153 11926 Frame set HD 4-leg
	1 x	197 10173 Accessories kit HD 4-leg table
2000 mm	153 11969 EAT3-HD-2000-004-01-S	
	1 x	153 11872 Cross beam set HD 4-leg 200
	1 x	153 11926 Frame set HD 4-leg FKP4
	1 x	197 10173 Accessories kit HD 4-leg table
Optional	1 x	197 10174 Connection set HD
Optional	1 x	158 10528 Extension set HD

Table 7 Components of HeavyDuty subframe; 4-leg Height Adjustment System

2.2 Manufacturer



SUSPA GmbH

Mühlweg 33

90518 Altdorf

GERMANY

2.3 Intended Use

The SUSPA ELS3-500S-BTU-Q-HD system including the HeavyDuty subframe is used for height adjustment of sitting and standing workbenches. The lifting elements and HeavyDuty subframes are designed for compressive loads.

IMPORTANT Please make sure that installation or start-up or the appropriate height adjustment has been selected. Please note in this regard the technical data (see Sec. 4.1 Technical Specifications), in particular the maximum load and adjustment range information.

Any other or otherwise expanded use of the Height Adjustment System including the HeavyDuty subframes is considered to be usage not in the manner intended and thus improper. In this case, the safety and protective functions of the Height Adjustment System may be impaired. SUSPA GmbH assumes no liability for damage resulting from such improper use.

Intended use also includes:

- following all instructions in the installation instructions
- following all the safety instructions
- compliance with the maintenance intervals

This partly completed machinery is intended to be incorporated into other machinery, other partly completed machinery/equipment or to be joined with another framework so as to form a complete machine as specified under the Machinery Directive. The machine should be put into operation only after a conformity evaluation procedure in accordance with the Machinery Directive has been carried out for the complete machine

2.4 Reasonably Foreseeable Misuse

Improper uses that could result in danger to the user, third parties or to the Height Adjustment System including the HeavyDuty tables frames, for all operating modes are:

- Using the Height Adjustment System including the HeavyDuty subframes and its electrical equipment contrary to its intended use
- The installation of the Height Adjustment System including the HeavyDuty subframes on components that are not approved by SUSPA GmbH for this system
- Improper installation, start-up, operation and maintenance of the entire system
- Operating the Height Adjustment System including the HeavyDuty subframe beyond the physical operating limits described in the chapter "Operating Conditions"
- Modifying the controller software without prior consultation with SUSPA GmbH
- Any modifications to the Height Adjustment System including the HeavyDuty subframes as well as any add-ons or conversions without prior consultation with the company, SUSPA GmbH
- Operating the entire Height Adjustment System contrary to specifications provided in the operating instructions regarding safety instructions, installation, operation, and malfunctions
- Operating the Height Adjustment System including the Heavy Duty subframes with apparent malfunctions and / or defects



WARNING

Danger of injury due to impermissible changes

Unauthorized modifications to the component as well as the use of spare parts from other manufacturers (not original spare parts) may pose risks.

Do not allow any unauthorized or other modifications to the component without prior approval of SUSPA GmbH.

IMPORTANT This appliance is not intended for use by persons (including children) with reduced physical, sensory or mental capabilities, or lack of experience and knowledge, unless they have been given supervision or instruction concerning use of the appliance by a person responsible for their safety. Children should be supervised to ensure that they do not play with the appliance.

2.5 General Instructions

2.5.1 Warranty and Liability

The "General Terms and Conditions" of SUSPA GmbH always apply. These are made available to the owner upon signing of the contract at the latest.

Warranty claims and liability claims for personal injury and material damage are excluded if they are attributed to one or more of the following causes:

- Improper use of the components
- Improper installation, start-up, operation and maintenance of the component
- Disregarding the information in the installation instructions
- Unauthorized constructive modifications to the Height Adjustment System including the HeavyDuty subframes
- Opening the individual components
- Inadequate implementation of the prescribed maintenance operations
- Disasters caused by external influence or force majeure
- Repairs that have not been carried out by the manufacturer's specialists

Read the installation instructions carefully before using and putting the components into operation. The installation instructions should familiarize the user with the handling of the components and instruct the user in the details associated with function and maintenance. The installation instructions must be made accessible to personnel at all times and must be kept available near the Height Adjustment System including the HeavyDuty subframes. The notes provided in the installation instructions regarding maintenance and operational safety must be observed and complied with. SUSPA GmbH would be pleased to answer any questions extending beyond the scope of these installation instructions.

2.5.2 Objectives of the Installation Instructions

These installation instructions serve as a support and contain all necessary instructions that must be observed and complied with for general safety, transport, installation, operation, setup, maintenance, storage and disposal.

These installation instructions with all safety instructions as well as all additional documents of the assemblies provided by external suppliers must be:

- Observed, read and understood by all persons working on the Height Adjustment System including the HeavyDuty subframes; this applies in particular to the safety instructions
- Must be made freely available to all persons
- Consulted even in case of slightest doubt (safety)

Objectives:

- To prevent accidents
- Increase the service life and reliability of the components
- To reduce the costs of production downtime

IMPORTANT The right to technical modifications in the context of continuous product improvement is reserved at all times without prior notification!

2.5.3 Target Audience of the Installation Instructions

At different life cycles of the Height Adjustment System, personnel with varied competences may come into contact with the Height Adjustment System including the HeavyDuty subframes.

Tasks	Operating personnel	Specialized personnel	Maintenance personnel	SUSPA	Private person
Shipping (Delivery)				X	
Transport (dispatching)		X		X	X
Start-up / installation		X	X	X	X
Operation	X	X	X	X	X
Error diagnosis	X	X	X	X	X
Troubleshooting by Error Code	X	X	X	X	X
Repair			X	X	
Decommissioning / Dismantling		X	X	X	X

Table 8 Target group

Operating personnel

A person who has been instructed and, if required, trained by a specialist in the tasks assigned to them, the possible dangers of improper conduct, the required safety equipment and safety measures.

Qualification of operating personnel

Of course, only those persons may work with the Height Adjustment System

- who are at least 18 years of age
- who are physically and mentally suitable for this purpose

Outside of the Federal Republic of Germany, the appropriate accident prevention regulations and safety regulations of the respective country apply.

Specialists

Persons who can evaluate the work assigned to them and recognize possible dangers on the basis of their specialized training, knowledge, experience and familiarity with the relevant standards.

Maintenance personnel

Maintenance personnel are persons with adequate technical training, knowledge and experience who are familiar with and know how to avoid mechanically or electrically induced hazards.

Maintenance personnel must meet the following requirements:

- Technical training
- Knowledge and experience
- Knowledge of applicable standards
- Ability to assess assigned works
- Ability to identify hazards

External professional personnel (SUSPA)

The external professional personnel are specially trained for the manufacturer's products and is familiar with every life stages of Height Adjustment System. The external professional personnel conduct the transport up to the transfer to the operator.

Private person

A person who has no previous knowledge in the installation of mechanical and electrical components.

3 Safety Instructions



WARNING

Danger of injury and material damage

There are dangers posed by ignoring the installation instructions and all safety instructions provided therein.

Read the installation instructions carefully before the initial start-up. Fulfill and follow the safety conditions required. Observe both the general safety instructions and also the special safety instructions provided in the other chapters.

The component has been constructed using state-of-the-art technology and in line with established safety regulations. In order to prevent danger to life and limb of the user, third parties, or to the component, use the component only for intended purpose and in perfect operating condition in terms of safety.

The operator of the component or the persons assigned by the same are liable for property damage and personal injury resulting from non-compliance with the instructions provided in the installation instructions.

3.1 Obligations



WARNING

Danger of injury by disregarding the safety symbols

There is risk of injury associated with disregarding the warning notices provided in the area of the component and in the installation instructions.

Please note all warning and safety instructions in these installation instructions.

The following circumstances could increase the hazard potential of the component:

- Danger posed to persons through mechanical influences
- Malfunctions that may impair the safety during operation of the component

3.1.1 Operating Company's Obligations

This partly completed machinery is intended to be incorporated into other machinery, other partly completed machinery/equipment or to be joined with another framework so as to form a complete machine as specified under the Machinery Directive. The machine should be put into operation only after a conformity evaluation procedure in accordance with the Machinery Directive has been carried out for the complete machine.

3.2 Residual Risk

IMPORTANT There is a residual risk posed by inadvertent movement of the drives. The following are determined as potential causes for this:

- Damaged cables
 - External influences (EMC)
 - Defects in the lifting elements, the controller or on the manual switch
- ➔ Take the residual risk into consideration with the construction and while preparing the operating instructions of the final product.

3.3 Safety Equipment

The component is fitted with various safety equipment. This equipment serves to protect persons working on the component from any danger to life and limb arising from electrical and mechanical operations and to limit material damage to the component.

3.4 Additional Instructions

In principle, the provisions of the accident prevention regulations of the professional association also apply to all work on the Height Adjustment System including the HeavyDuty subframes.

In addition, observe and follow the

- Applicable and binding accident-prevention regulations
- Applicable and binding regulations at the place of use
- Recognized technical regulations for safe and professional working methods
- Existing environmental protection regulations
- Other applicable regulations

4 Design and Function

4.1 Technical Specifications

Technical Specifications – ELS3-500-HeavyDuty Height Adjustment System	
Installation dimensions (Lifting element)	
External profile / external tube dimensions:	70 x 70 mm
Internal tube dimensions:	65 x 65 mm
Motor housing dimensions:	202 mm x 120 mm x 56 mm
Stroke (L stroke):	500 mm
Retracted length L_{in} :	680 mm
Extended length L_{out} :	1180 mm
Fastening structure:	12 x M6
Fasting on foot stabilizer:	4 x M8
Controller	
Input voltage:	230 V / 50 Hz (2,7 A)
Output rating:	28 VDC 340 VA at 10% ED (1 min one at 25° C)
Standby use:	< 4 W (Standard); <0,4 W (Optional)
Protection class II:	Protective insulation
Performance data	
Operating speed:	approx. 20 mm/s
Max. lifting capacity and holding load per lifting element:	100 kg
Max. lifting capacity and holding load with 4-leg system:	400 kg
Duty cycle:	10% (Traversing time 2 min; Break time 18 min)
Protection type	
Lifting elements:	IP 20 in accordance with DIN EN 60529
Controller:	IP 40 in accordance with DIN EN 60529
Manual switch:	IP 40 in accordance with DIN EN 60529
Traversing cycles	
At least 10,000 cycles in compliance with maintenance	

Table 9 Technical Specifications

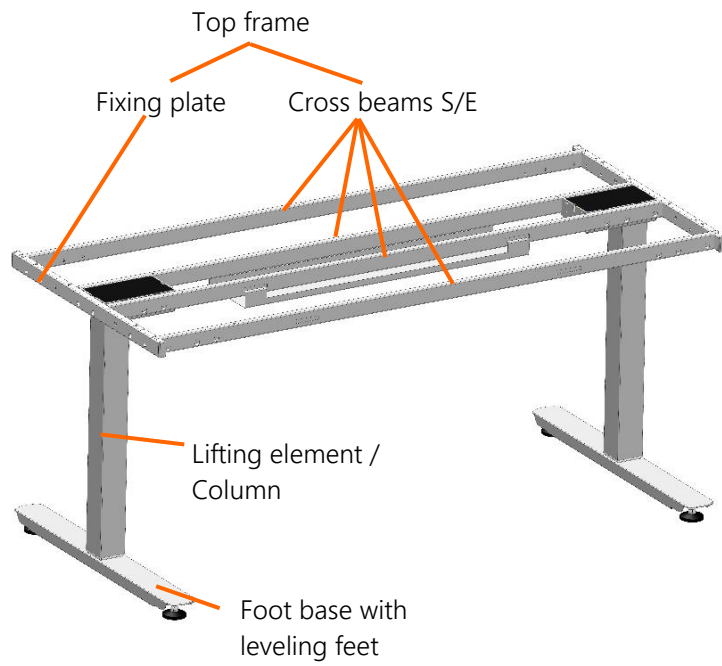

Figure 1: 2-leg HeavyDuty subframe

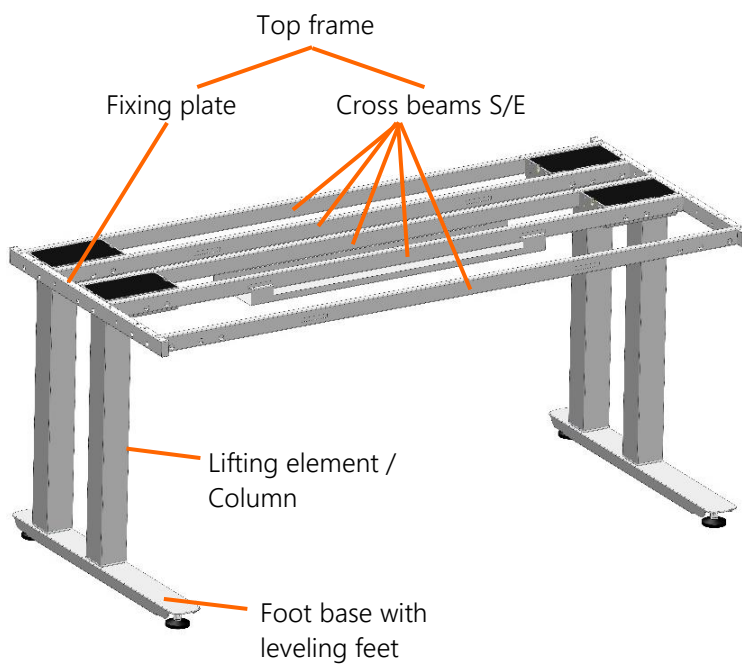

Figure 2: 4-leg HeavyDuty subframe

Technical Specifications – HeavyDuty subframe (2-leg and 4-leg)			
Top frame:	Characteristics		
Subframe lengths:	1600 mm	1800 mm	2000 mm
Cross beam S (can be fastened with screws):	1559 mm	1759 mm	1959 mm
Cross beam E (can be hooked in):	1587 mm	1787 mm	1987 mm
Cross beam material:	DIN EN 10305-5 40x20x2		
Cross beam surface:	powder-coated anodized silver matte 069/90025		
Fixing plate length:	700 mm		
Fixing plate material:	DIN EN 10305-5 40x20x2		
Fixing plate surface:	powder-coated anodized silver matte 069/90025		
for tabletop lengths:	1600 mm	1800 mm	2000 mm
for tabletop depths:	700 – 800 mm		
Max. permissible load:	200 kg (2-leg) or 400 kg (4-leg)		
Accessories:	Screws, spacer elements, washers		
For lifting elements / columns:	Type: ELS3-500S-BTU-Q-S-HD		

Table 10 HeavyDuty subframe technical specifications

Extension foot (Base):	Characteristics		
Base length:	770 mm		
Base width:	80 mm		
Base material:	DIN EN 10219-1 S235JRH 80x30x3 mm		
Base surface:	powder-coated anodized silver matte 069/90025		
Max. permissible load:	200 kg (2-leg) or 400 kg (4-leg)		
Accessories:	Screws, washers and adjustable feet		
For lifting elements / columns:	Type: ELS3-500S-BTU-Q-S-HD		

Table 11: Technical specifications of extension foot (Base)

IMPORTANT The noise emission level of the Height Adjustment System including the HeavyDuty subframe is considerably less than 70 dBA.

4.2 Design and Function of the Height Adjustment System Including the HeavyDuty Subframes

The lifting elements are driven by electric motors and synchronized by an electric controller. The system works purely electromechanically. The Height Adjustment System is optimized for OEM or retrofit applications and consists of three important subsystems:

- Electrical lifting element
- Electrical controller
- Manual switch
- HeavyDuty subframes (2-leg and 4-leg)

The following explains how the subsystems work together and make the raising and lowering of the Height Adjustment System possible.



Figure 3 Electrical controller SMS SCT4



Figure 5 Simple manual switch UBM-F/2-p



Figure 6 Programmable manual switch UBS/6-LCD (optional)

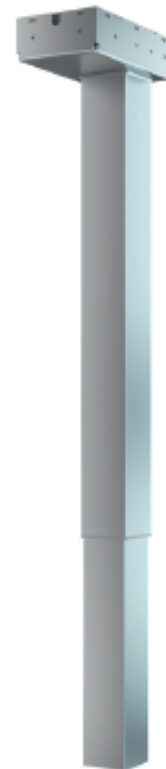

Figure 4 Electrical lifting element

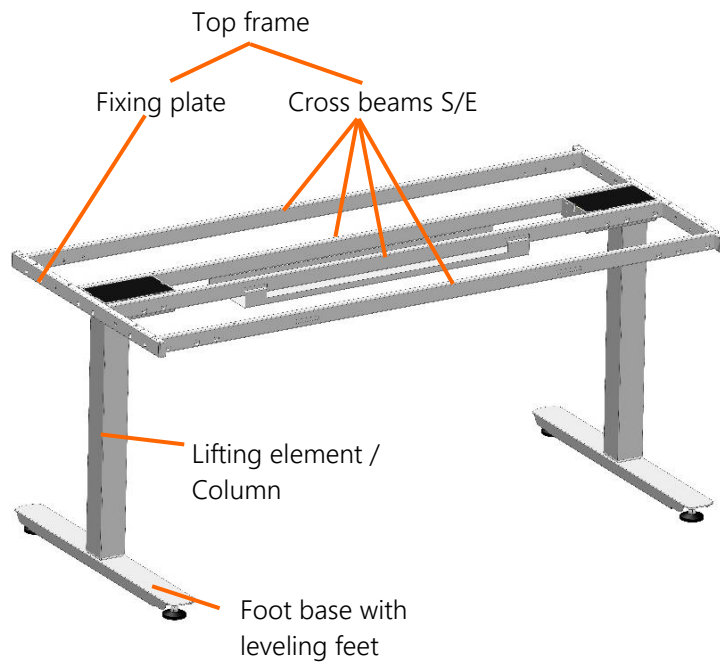

Figure 7: 2-leg HeavyDuty subframe

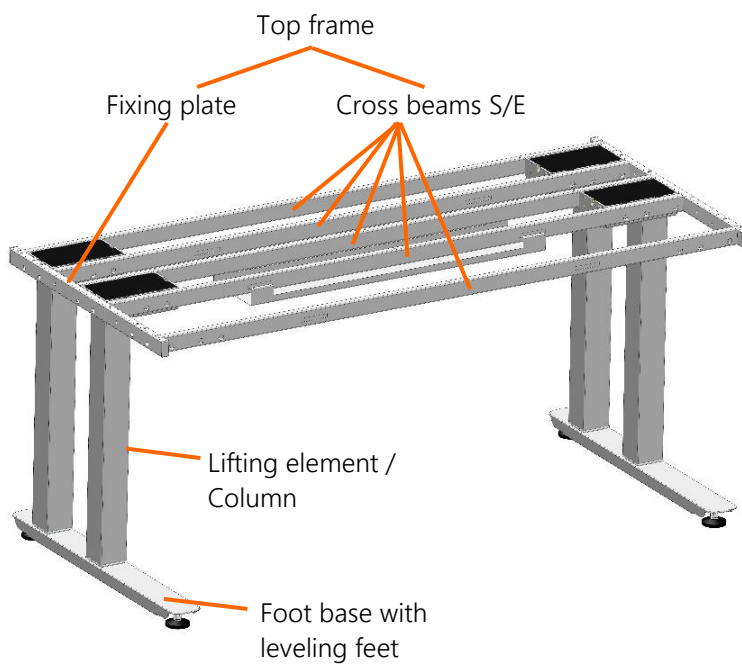

Figure 8: 4-leg HeavyDuty subframe

The lifting elements permanently connected with the respective HeavyDuty subframe are fitted with electro-mechanical drives. The controller converts AC power to 28V DC to operate the motors with pulse width modulation (PWM 15 kHz 0 - 100%). The controller is used to activate the raising and lowering of the lifting elements of the Height Adjustment System.

As soon as the operator presses the arrow keys (Up or Down) of the manual switch connected to the controller, the latter receives the signal to set the electro-mechanical drive of the lifting elements in motion. Depending on the direction of the arrow the motor moves the lifting elements up or down.

5 Transport

5.1 Safety Instructions for Transport



WARNING

Danger of falling loads

There are risks caused by human misconduct and inadequately secured loads.

Allow only those individuals who have been specially trained to perform transportation work.
Secure the load against changing its position.

Pay attention to the position of the center of gravity of the component during transport.

Secure the component for transport by heavy goods vehicle on the loading surfaces with suitable means.



WARNING

Danger of injury due to unsecured transport routes

There is the risk of stumbling or slipping while transporting the components.

Arrange for proper illumination of the routes, ramps and steps over which loads are moved.
Remove obstacles and stumbling points.

CAUTION

Damage caused by improper transport

Transport with extended lifting elements may result in risk of damage to property or personal injury.

Retract the lifting element completely when transporting.

5.2 Transportation Procedure

The components have to be moved by suitable means. Use suitable cables, chains or straps for loading and unloading according to the load / weight.

IMPORTANT The shipment must be made by professional personnel of SUSPA GmbH. The further transport must be made by professional personnel and private persons. The following points must be observed for transporting / unloading of the components:

- ➔ Note the center of gravity.
- ➔ Avoid rubbing cables and lifting straps against sharp edges and corners.
- ➔ Check the delivered components for completeness, damage or any other abnormalities.
- ➔ Observe the applicable safety and accident prevention regulations during transport.

6 Installation



⚠ CAUTION

Danger of crushing

There is a risk of crushing due to the short distance to other objects and structures.

Make sure that the work surface has a minimum distance of 50 mm from other objects or structures. Make sure that walls, furniture, electrical wiring, or other solid structures do not impede the movement of the work surface during operation.

IMPORTANT The installation of the component must be carried out by professional personnel of SUSPA GmbH, other professional personnel, maintenance personnel and private persons.

IMPORTANT Do not lift the Height Adjustment System on the motor cables or power cords. Keep the motor cable and power cable away from heat, sharp edges, and moisture. Immediately suspend the operation of the product if you notice that the motor cable or power cord are damaged and replace the damaged components without delay. Never attempt to repair damaged motor cables or power cords.

IMPORTANT Check all components for any damage that may have occurred during transport or installation before operating the system. Do not try to dismantle the system or system components. Contact SUSPA GmbH in the event that components must be repaired or replaced.

6.1 Unpacking

Proceed with the necessary diligence and caution when unpacking the system components. Do not use any sharp-edged objects, cutters or knife blades in order to prevent damage to near electrical cables or components that may get damaged easily.

6.1.1 Disposal of Transport and Warehouse Packaging

The disposal of the transport and warehouse packaging should be performed in accordance with the local disposal regulations and environmental protection laws applicable in the operator's country.

6.1.2 Checklist of All Components Included in the Delivery

Check the completeness of the delivery while unpacking the components. Use the appropriate delivery notes on the contents of the pallets and the manufacturer's packing list for this purpose.

Examples of scope of delivery would be:

For a 2-leg system including the HeavyDuty subframe:

2-leg Height Adjustment System	
2 x	Electrical lifting elements
2 x	Adapter cable DIN (female) to Molex (male)
1 x	Electrical controller
1 x	Connector cable for non-heating appliance
1 x	Manual switch

Table 12 Scope of supply for a 2-leg Height Adjustment System

2-leg HeavyDuty subframe		
Subframe length	153 11964 EAT3-HD-1600-002-01-S	
1600 mm	1 x	153 11873 Cross beam set HD 2-leg 160
	1 x	153 11925 Frame set HD 2-leg
	1 x	197 10172 Accessories kit HD 2-leg table
1800 mm	153 11965 EAT3-HD-1800-002-01-S	
	1 x	153 11881 Cross beam set HD 2-leg 180
	1 x	153 11925 Frame set HD 2-leg
	1 x	197 10172 Accessories kit HD 2-leg table
2000 mm	153 11966 EAT3-HD-2000-002-01-S	
	1 x	153 11874 Cross beam set HD 2-leg 200
	1 x	153 11925 Frame set HD 2-leg
	1 x	197 10172 Accessories kit HD 2-leg table
Optional	1 x	197 10174 Connection set HD
Optional	1 x	158 10528 Extension set HD

Table 13 Scope of supply for a 2-leg HeavyDuty subframe

For a 4-leg system including the HeavyDuty subframe:

4-leg Height Adjustment System	
4 x	Electrical lifting elements
4 x	Adapter cable DIN (female) to Molex (male)
1 x	Electrical controller
1 x	Connector cable for non-heating appliance
1 x	Manual switch

Table 14 Scope of supply for a 4-leg Height Adjustment System

4-leg HeavyDuty subframe		
Subframe length	153 11967 EAT3-HD-1600-004-01-S	
1600 mm	1 x	153 11871 Cross beam set HD 4-leg 160
	1 x	153 11926 Frame set HD 4-leg
	1 x	197 10173 Accessories kit HD 4-leg table
1800 mm	153 11968 EAT3-HD-1800-004-01-S	
	1 x	153 11880 Cross beam set HD 4-leg 180
	1 x	153 11926 Frame set HD 4-leg
	1 x	197 10173 Accessories kit HD 4-leg table
2000 mm	153 11969 EAT3-HD-2000-004-01-S	
	1 x	153 11872 Cross beam set HD 4-leg 200
	1 x	153 11926 Frame set HD 4-leg FKP4
	1 x	197 10173 Accessories kit HD 4-leg table
Optional	1 x	197 10174 Connection set HD
Optional	1 x	158 10528 Extension set HD

Table 15 Scope of supply for a 4-leg HeavyDuty subframe

6.2 Operating Conditions

Physical operating conditions	
Operating range:	Functional operation <ul style="list-style-type: none"> ▪ Min + 5 °C ▪ Max + 40 °C Relative moisture: <ul style="list-style-type: none"> ▪ Max 80% at 32 °C, above that decreasing linearly to 50% at 40 °C
Contamination:	No heavy contamination due to dust, acids, corrosive gases

Table 16 Operating conditions

- ➡ Do not operate the system outdoors. Do not expose the system to damp or wet conditions.
- ➡ Avoid environments with chemical agents or corrosive environments.
- ➡ Do not operate the system near flammable solvents, propellants and/or explosive substances (e.g. gas, vapor, dust, etc.).
- ➡ Do not expose the components of the Height Adjustment System including the HeavyDuty subframe to any vibrations and/or shock loads.
- ➡ Do not use the controller near the equipment that generates strong electromagnetic fields. This may impair the function.
- ➡ In order to prevent overheating in the controller, it should not be installed in constrained, non-ventilated or thermally insulating locations. Adequate air circulation must be ensured.

IMPORTANT Observe the country-specific regulations regarding setup and operation of work surfaces with respect to lighting of the workstations.

For example: Lighting in accordance with ASR A3.4

The Technical Rules for Workstations (ASR) reflect the state of the art technology, occupational medicine and occupational hygiene and other sound knowledge for the setup and operation of workstations.

The values given in the table are the intensity of illumination on the reference area for visual tasks that may be horizontal, vertical or inclined.

Lighting requirements (metal machining and processing, foundries and casting)		
Working rooms, workplaces and jobs	Minimum value of the illumination intensity In lx	Minimum value of the color rendering Index Ra
Metal machining and processing, foundries and casting		
Assembly work:		
- Rough	200	80
- Medium-fine	300	80
- Fine	500	80
- Very fine	750	80

Table 17 Lighting requirements

6.3 Install Components

- Note the exact information of the installation dimensions provided in the schematic diagrams of the Height Adjustment System including the HeavyDuty subframe.

6.3.1 Installation in General

⚠ CAUTION Electrical components (lifting elements, electrical controllers, manual switches) should be connected or disconnected only with the power plug pulled out!

- Apply the load to the system in such a way that it is balanced (uniformly distributed) as much as possible both on the HeavyDuty subframe as well as on the lifting elements.
- Attach the lifting elements vertically and parallel to each other, so that they do not block each other during lifting and lowering.
- Satisfy yourself that the mounting screws supplied along with the subframe and the lifting elements are fastened securely according to the specifications.
- Keep electrical cord away from sharp edges and moving parts.
- Avoid contact with moisture and heat.
- Attach the electrical wires and power cords to the workstation or structure using cable ties or clips.

IMPORTANT When routing electrical cables and power cords, make sure that the wires are not stretched or crushed. Position the power cord to prevent tripping hazards. Use only accessories authorized and provided by SUSPA.

The Height Adjustment System including the HeavyDuty subframe works properly only if it has been put into operation properly and individual components are controlled correctly.

- ➔ First check whether the individual components are damaged. If this is the case, do not put the Height Adjustment System including the HeavyDuty subframe into operation, but have the damaged components replaced by your supplier.
- ➔ Also check the power cable for damage. Make sure to replace damaged power cables in any case.

6.3.2 Mounting the Lifting Elements Including the HeavyDuty Subframe

- ➔ Remove the protective packaging in which the lifting elements and the components of the HeavyDuty subframe are packaged.



Figure 9 Packaging

















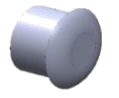













Accessories kit for HD 2-leg table						
4x Leveling foot 	8x Screw M8x50 	8x Washer M8 	12x Sleeve 	12x Screw M6x25 	4x Screw M6x10 	12x Cover plugs 
12x Rear wall screw, 5.0x60mm 	2x Pan Head screw 4.0x20 	4x Pan Head screw 5.0x20 	12x Unita screw 7.0x55 	2x Pan Head screw 5.0x30 	2x Cable clamps Eltric 130 mm 	
Accessories kit for HD 4-leg table						
4x Leveling foot 	16x Screw M8x50 	16x Washer 8.4x15 	24x Sleeve 	24x Screw M6x25 	8x Screw M6x10 	12x Cover plugs 
15x Rear wall screw, 5.0x60mm 	2x Pan Head screw 4.0x20 	4x Pan Head screw 5.0x20 	12x Unita screw 7.0x55 	2x Pan Head screw 5.0x30 	2x Cable clamps Eltric 130 mm 	
Connecting set HD (Optional)						
2x Screw M8x50 		4x Washer 8.4x20 		2x Self-locking nut M8 		
Extension set HD (Optional)						
1x Extension bracket, right side 		1x Extension bracket, left side 		4x Allen screw M6x16 		

Figure 10 Scope of supply for mounting accessories

6.3.2.1 Assembling Lifting Elements Including the 2-Leg HeavyDuty Subframe

Assembling the top frame

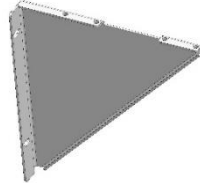
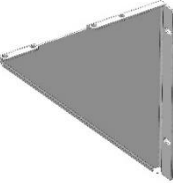
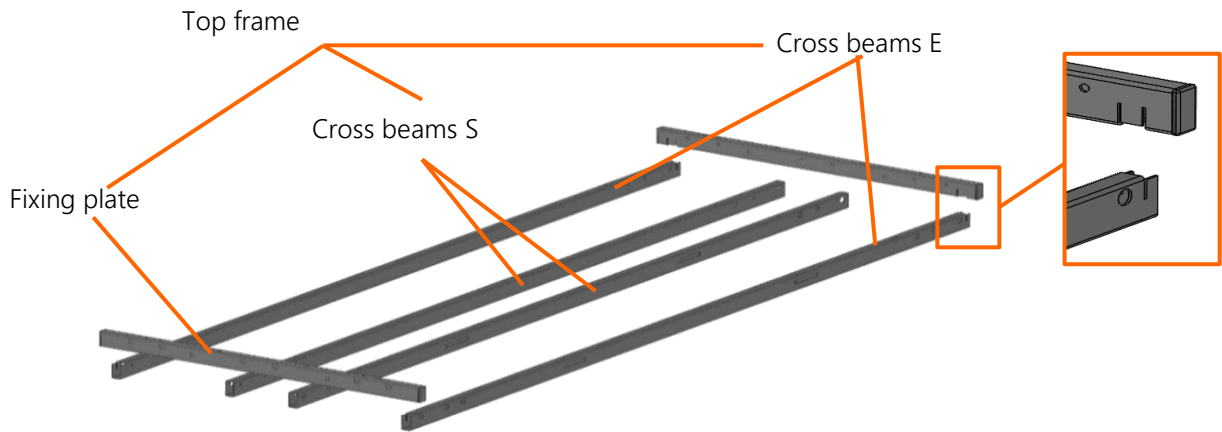

Figure 11 Assembling the top frame of the 2-leg system

For the assembly of the top frame, the cross beams E and S are placed on the floor as illustrated in Figure 11. In the next step, the fixing plates are hooked into the two cross beams E. The finally assembled top frame is illustrated in Figure 12.

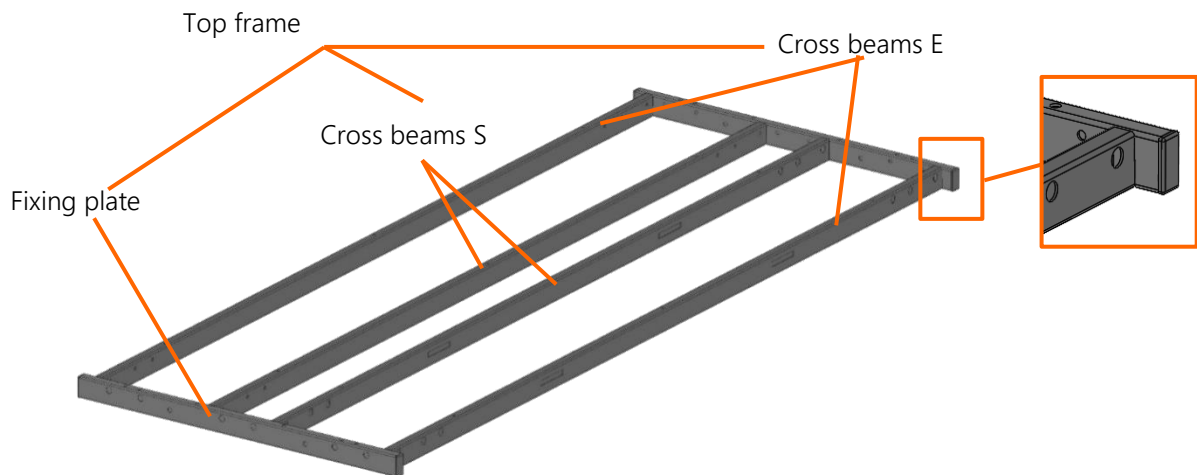

Figure 12 Assembled top frame of the 2-leg system

Assembling the lifting elements with the top frame

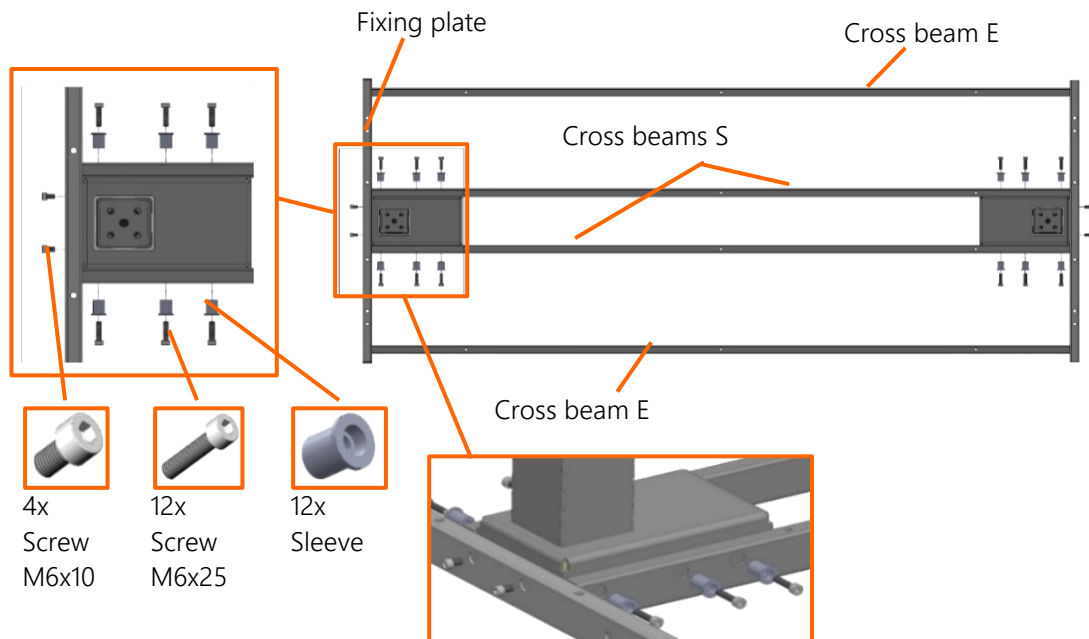

Figure 13 Assembly of lifting elements of the 2-leg system with top frame

- Fasten each lifting element with the help of the M6 screws supplied. Tool required: Size 5 Allen wrench



Figure 14 Size 5 Allen wrench

- The M6x10 screws are used for mounting the fixing plates on the lifting elements. Two M6x10 screws are required for mounting each fixing plate. The screws are inserted into the fixing plate and fixed to the lifting element.
- The two cross beams S are fastened with the sleeves (12 pieces) and the screws M6x25 (12 pieces) to the lifting elements as described in Figure 12.
- Check the mounting screws of the lifting elements in order to ensure that they are fastened securely to the HeavyDuty subframe. Take care not to over-tighten the lifting element mounting screws (recommended tightening torque: max. 7 Nm).
- Make sure that the electrical lines of each leg of the work surface can be laid without putting them under mechanical tension by maintaining the permissible bending radius of 57 mm (single) and 86 mm (multiple). The electrical wires to the lifting elements are each 1.2 m long.

IMPORTANT In order to prevent damage to the lifting elements and the HeavyDuty subframe, use only the screws and fastening elements that are included in the scope of supply.

Assembling the foot bases on the lifting elements

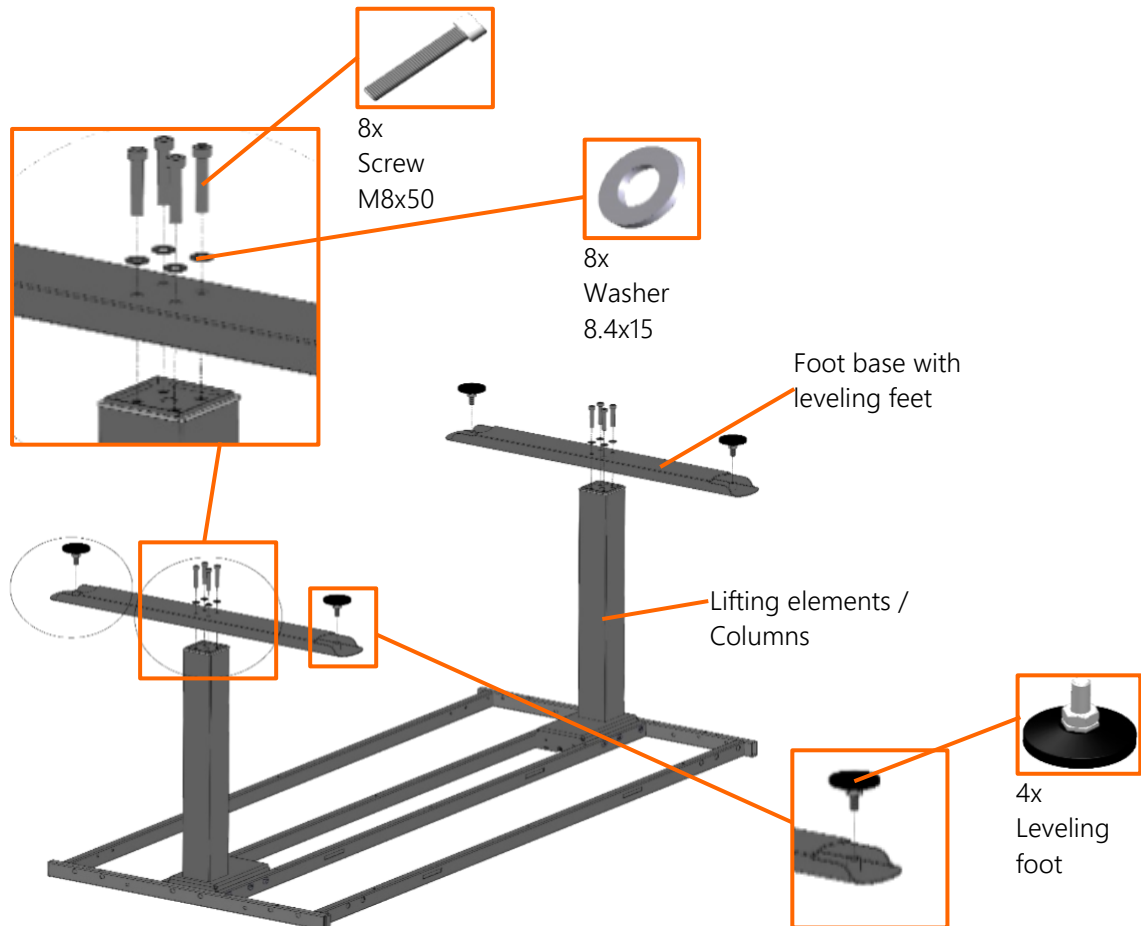

Figure 15 Assembling the foot bases of the 2-leg system

- Place the foot bases on the lifting elements and fasten these with the M8x50 screws and M8 washers supplied to the lifting elements. Use a size 6 Allen wrench to fit the screws.
- Check the mounting screws of the foot bases in order to ensure that they are fastened securely to the lifting elements. Take care not to over-tighten the lifting element-mounting screws (recommended tightening torque: 10 Nm).
- Fit the leveling feet with screws by hand in the foot bases. The alignment of the 2-leg system with the HeavyDuty subframe is described in section 6.5 "Aligning components".

IMPORTANT In order to prevent damage to the lifting elements and the HeavyDuty subframe, use only the screws and fastening elements that are included in the scope of supply.

Mounting the cover plugs

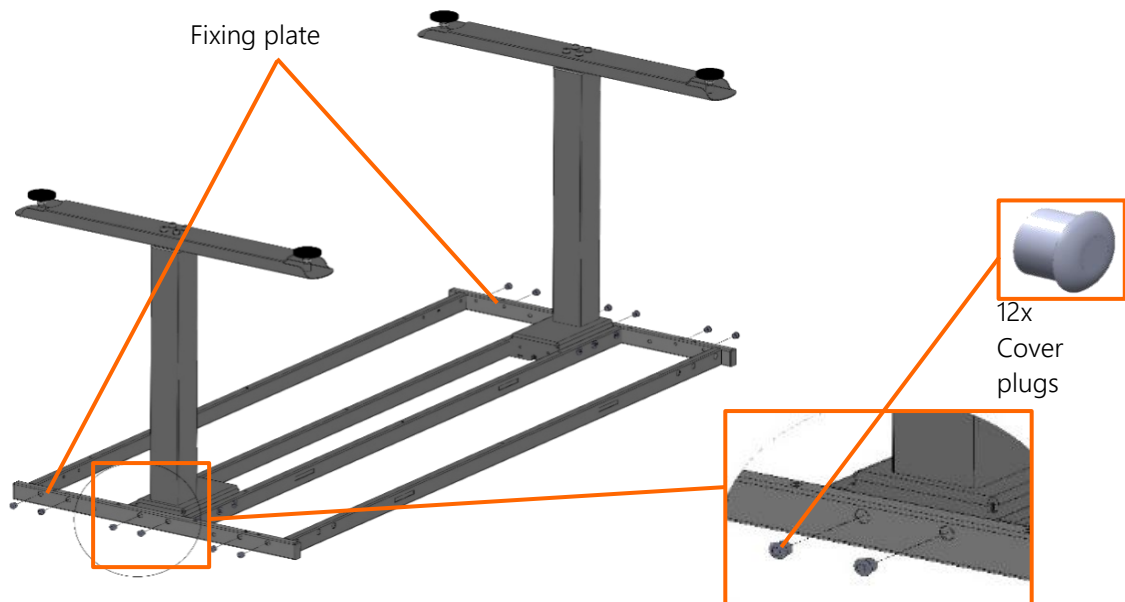

Figure 16 Mounting the cover plugs of the 2-leg system

- ➔ After the complete installation of the lifting elements including the lower subframe, the cover plugs are mounted in the fixing plate as illustrated in Figure 16.

Mounting the cable tray

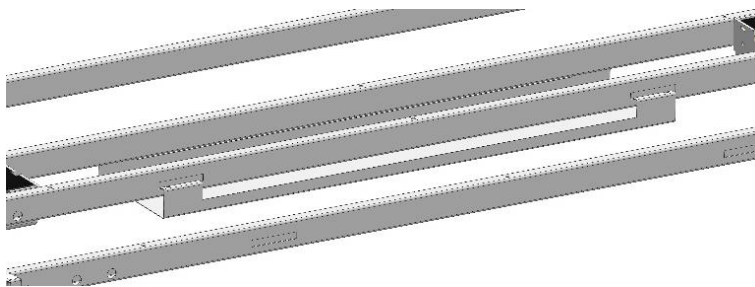

Figure 17 Cable tray hooked into the cross beams S

The clips of the cable tray are hooked into the cavities of the two middle cross beams S.

Optional: Mounting the connection set HD

The mechanical coupling of two complete 2-leg table systems is possible with an optional connection set HD. However, in doing so, you have to note that these two 2-leg table systems also have to be connected electrically with one another!

If more than four lifting elements are used in a Height Adjustment System, then the two electrical controllers must be connected to the connector contacts of the electrical connector with a link cable (Order number 198 10134). In the process, please consider the procedure described in chapter 6.3.5 Overall Installation.

IMPORTANT The ELS3 HeavyDuty Height Adjustment System can be supplied in different versions. The supply variants contain 1 to 8 lifting elements. There is a different controller variant depending on the supply variant. The correct variant of the controller can be supplied only if you specify the supply variant at the time of placing the order.

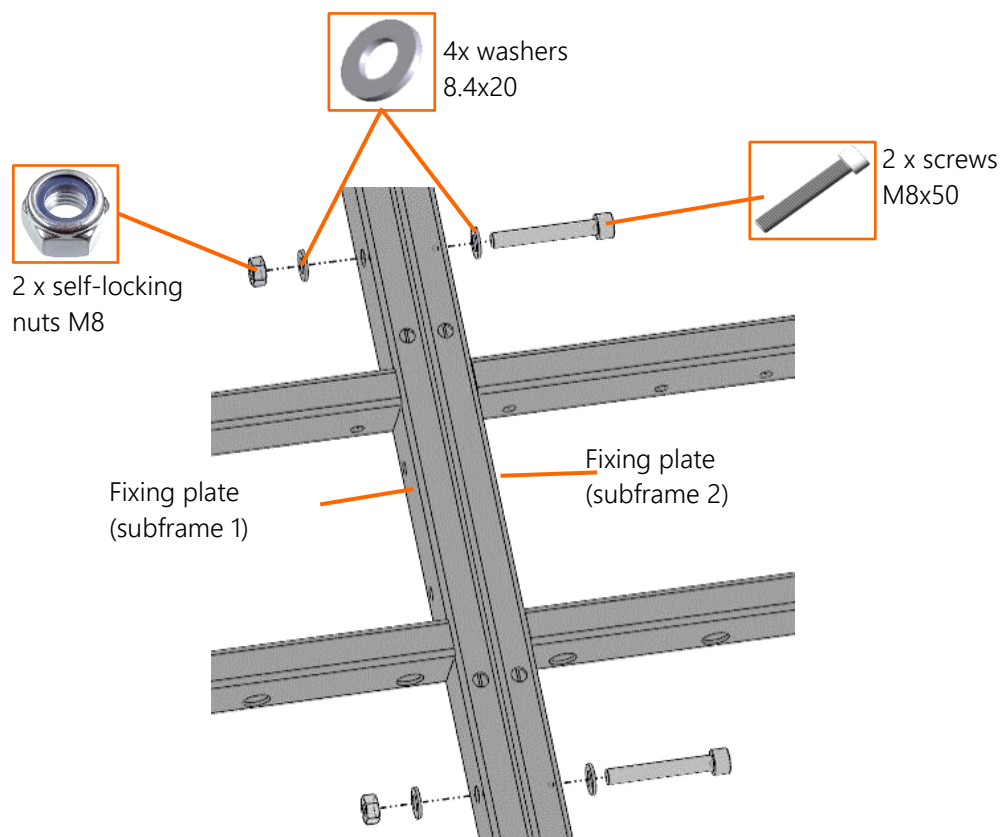

Figure 18 Connection set of the HD 2-leg system

Place the fixing plates of the two subframes exactly next to one another and screw the two fixing plates tightly to one another with the M8x50 screws, the M8 washers and the self-locking M8 nut supplied. Use a size 6 Allen wrench for mounting the screws and a size SW17 open-end wrench for the self-locking nuts.

Check the mounting screws of the connection set HD to ensure that the tow fixing plates are fixed tightly to one another. Take care not to over-tighten the mounting screws (recommended tightening torque: max. 10 Nm).

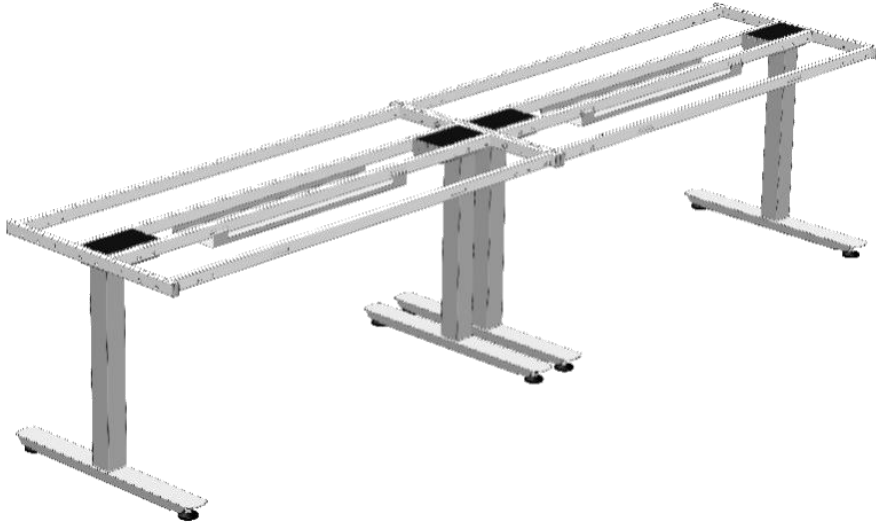

Figure 19 Connection set of the HD 2-leg system: connected subframes

Optional: Mounting the extension set HD

The extension set HD enables connection of commercially available extension elements (e.g. aluminum profiles, holding rails, trays, perforated tabletops) to the rear side on the frame of the ELS3 HeavyDuty subframe.

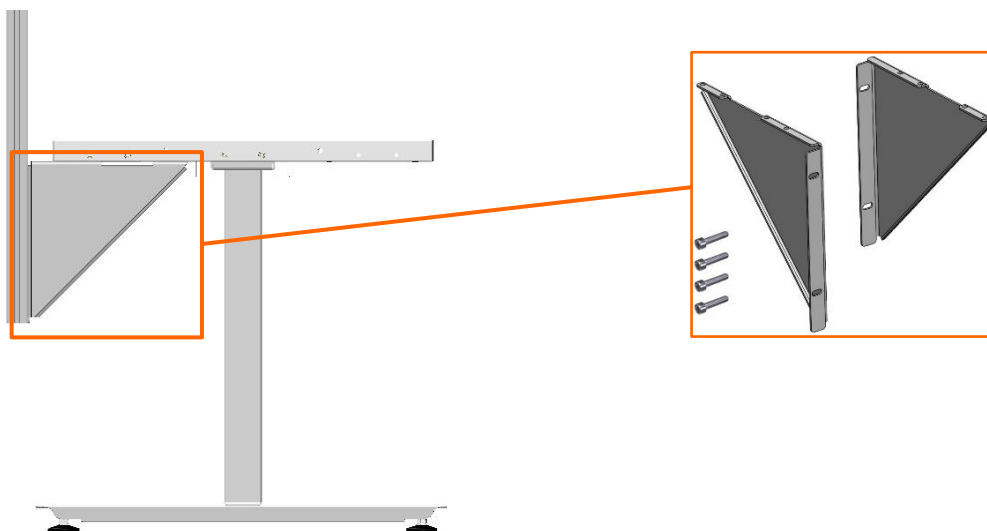

Figure 20 Extension set of the HD 2-leg system

In the process, you have to consider that additional loads attached to the rear side does not cause any risk of tipping over for the HeavyDuty subframe and the max. permissible load of every individual HeavyDuty subframe is complied with.

Mounting accessories for mounting the customized tabletop

IMPORTANT The tabletop is not available in the SUSPA scope of supply since this is freely selectable by the customer depending on the application and design requirement.

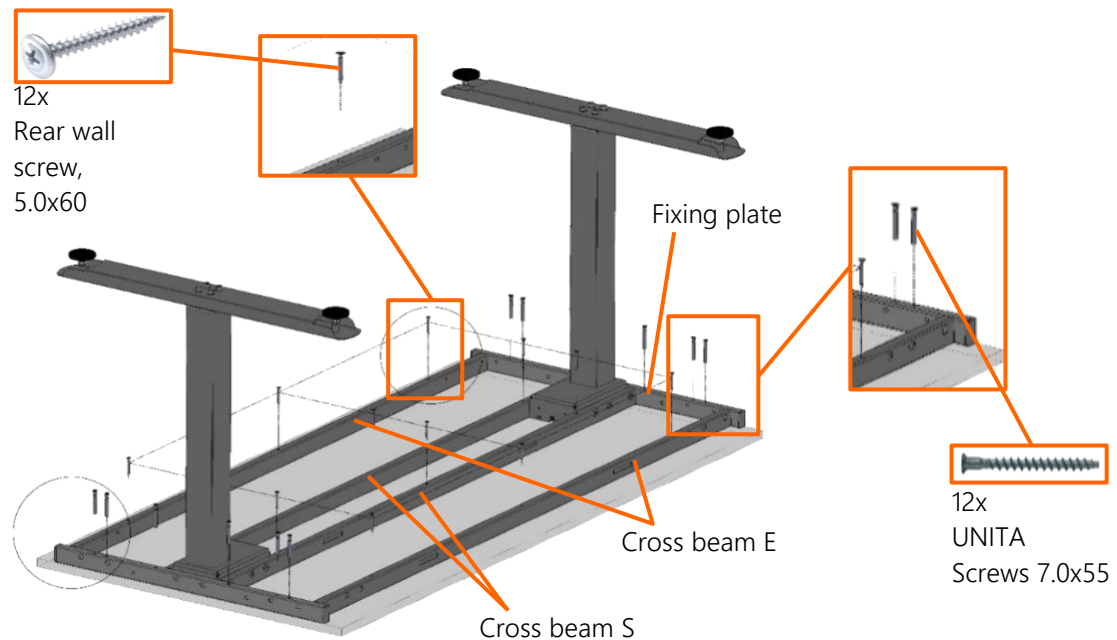

Figure 21 Mounting the tabletop (not included in the scope of supply) on the 2-leg HeavyDuty subframe

- With the customer's selection of the tabletop dimensions, you have to note that the projection of the tabletop borders to the HeavyDuty subframe is only 10 cm maximum, since otherwise there is a great risk of tipping over on load application.
- For mounting the tabletop provided by the customer, the 2-leg system is placed with the HeavyDuty subframe on the tabletop (not included in the scope of supply by SUSPA). The system can be mounted on the tabletop with the help of the screws supplied along with the remaining items in the scope of supply.
- You can use the rear wall screws (5.0x60) to mount the tabletop on the cross beams S and the cross beams E. The fixing plates can be mounted with the UNITA screws (7.0x55) to the tabletop.
- You have to first drill suitable bore holes in the tabletop before you can insert these mounting screws. The diameter of the preliminary drilling depend on the tabletop material used by the customer.
- You can insert the rear wall screws and the UNITA screws with the help of screwdriver or a battery-operated screwdriver.

6.3.2.2 Assembling Lifting Elements Including the 4-Leg HeavyDuty Subframe

Assembling the top frame

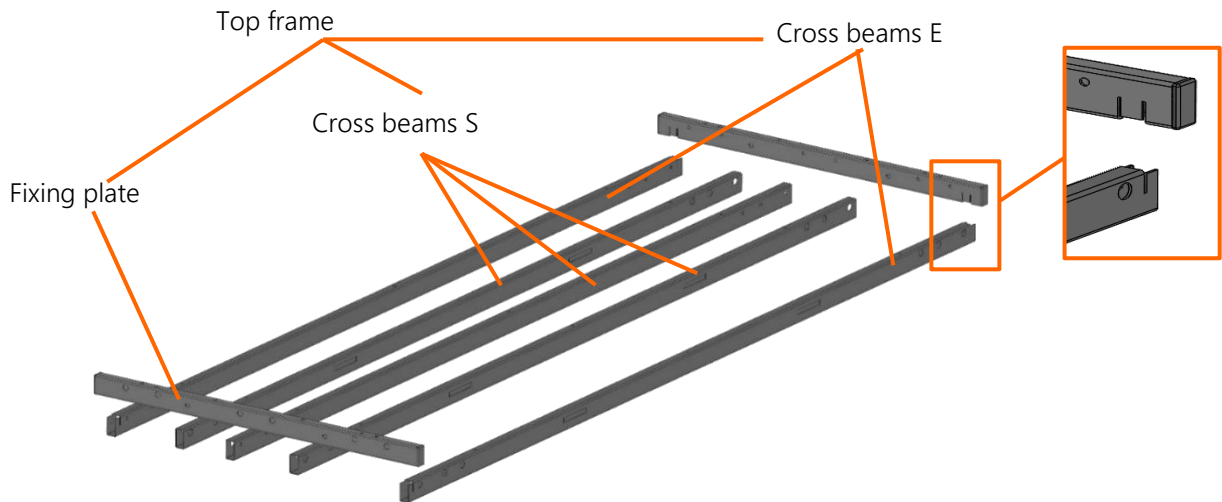

Figure 22 Assembling the top frame of the 4-leg system

For the assembly of the top frame, the cross beams E and S are placed on the floor as illustrated in Figure 16. In the next step, the fixing plates are hooked into the two cross beams E. The finally assembled top frame is illustrated in Figure 23.

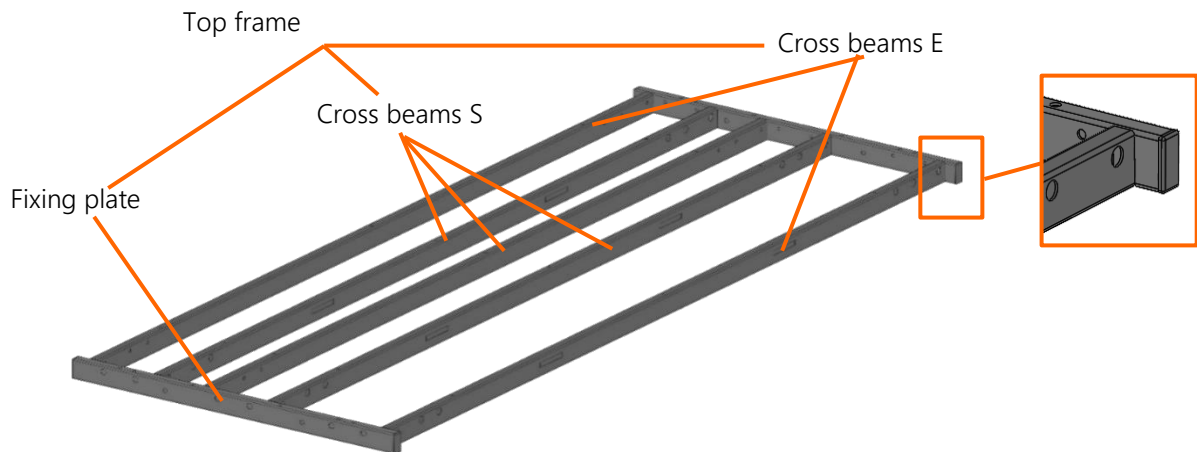

Figure 23 Assembled top frame of the 4-leg system

Assembling the lifting elements with the top frame

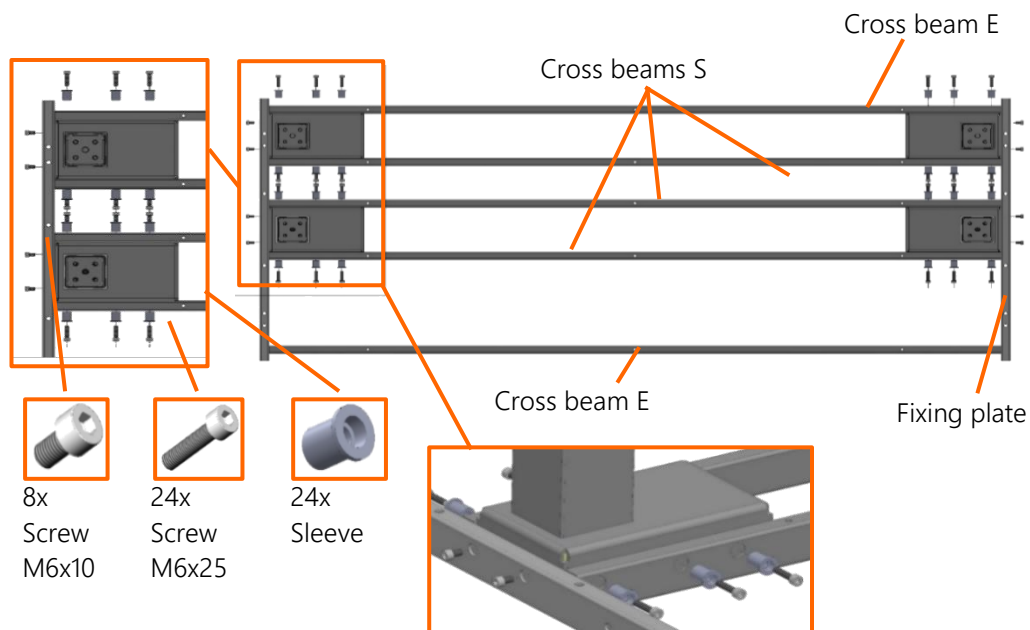

Figure 24 Assembly of lifting elements of the 4-leg system with top frame

- Fasten each lifting element with the help of the M6 screws supplied. Tool required: Size 5 Allen wrench



Figure 25 Size 5 Allen wrench

- The M6x10 screws are used for mounting the fixing plates on the lifting elements. Four M6x10 screws are required for installing each fixing plate. The screws are inserted into the fixing plate and fixed to the lifting element.
- The three cross beams S and one cross beam E are fastened with the sleeves (24 pieces) and the screws M6x25 (24 pieces) to the lifting elements as described in Figure 18.
- Check the mounting screws of the lifting elements in order to ensure that they are fastened securely to the HeavyDuty subframe. Take care not to over-tighten the lifting element mounting screws (recommended tightening torque: max. 7 Nm).
- Make sure that the electrical lines of each leg of the work surface can be laid without putting them under mechanical tension by maintaining the permissible bending radius of 57 mm (single) and 86 mm (multiple). The electrical wires to the lifting elements are each 1.2 m long.

IMPORTANT In order to prevent damage to the lifting elements and the HeavyDuty subframe, use only the screws and fastening elements that are included in the scope of supply.

Assembling the foot bases on the lifting elements

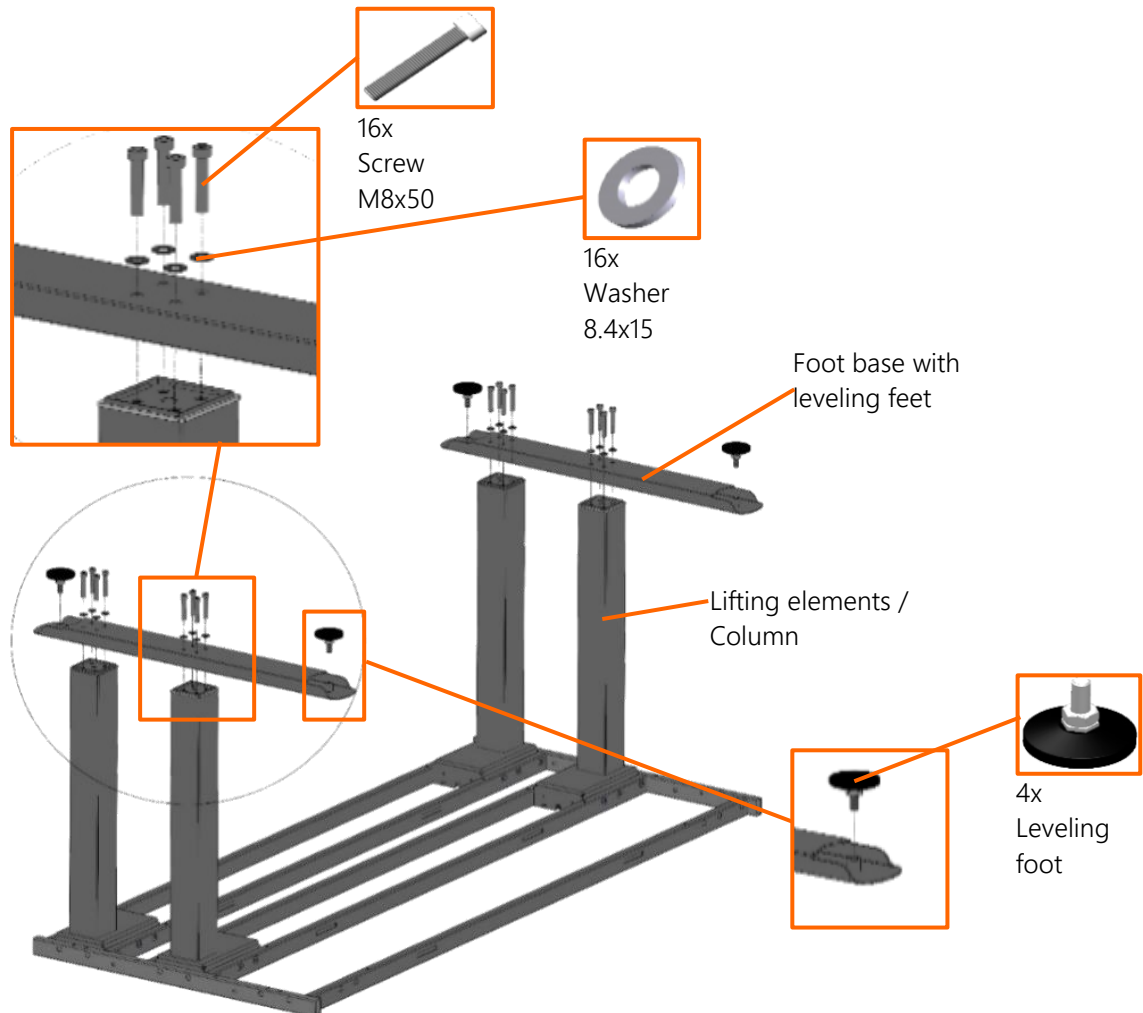

Figure 26 Assembling the foot bases of the 4-leg system

- ➔ Place the foot base on the lifting elements and fasten these with the M8x50 screws and M8 washers supplied to the lifting elements. Use a size 6 Allen wrench to fit the screws.
- ➔ Check the mounting screws of the foot bases in order to ensure that they are fastened securely to the lifting elements. Take care not to over-tighten the lifting element-mounting screws (recommended tightening torque: 10 Nm)

- ➔ Fit the leveling feet with screws by hand in the foot bases. The alignment of the 4-leg system with the HeavyDuty subframe is described in section 6.5 "Aligning components".

IMPORTANT In order to prevent damage to the lifting elements and the HeavyDuty subframe, use only the screws and fastening elements that are included in the scope of supply.

Mounting the cover plugs

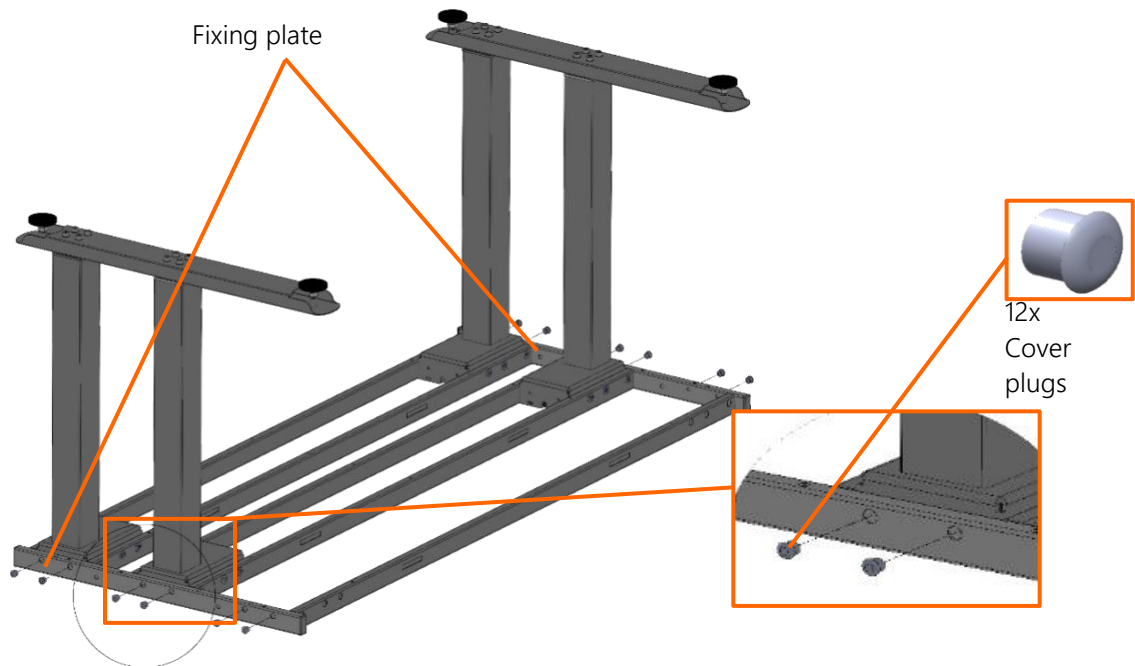

Figure 27 Mounting the cover plugs of the 4-leg system

- ➔ After the complete assembly of the lifting elements including the lower subframe, the cover plugs are installed in the fixing plate as illustrated in Figure 20.

Mounting the cable tray

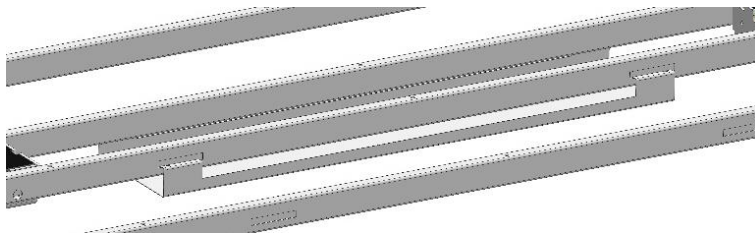

Figure 28 Cable tray hooked into the cross beams S

The clips of the cable tray are hooked into the cavities of the two middle cross beams S.

Optional: Mounting the connection set HD

The mechanical coupling of two complete 2-leg table systems is possible with an optional connection set HD. However, in doing so, you have to note that these two 2-leg table systems also have to be connected electrically with one another!

If more than four lifting elements are used in a Height Adjustment System, then the two electrical controllers must be connected to the connector contacts of the electrical connector with a link cable (Order number 198 10134). In the process, please consider the procedure described in chapter 6.3.5 Overall Installation.

IMPORTANT The ELS3 HeavyDuty Height Adjustment System can be supplied in different versions. The supply variants contain 1 to 8 lifting elements. There is a different controller variant depending on the supply variant. The correct variant of the controller can be supplied only if you specify the supply variant at the time of placing the order.

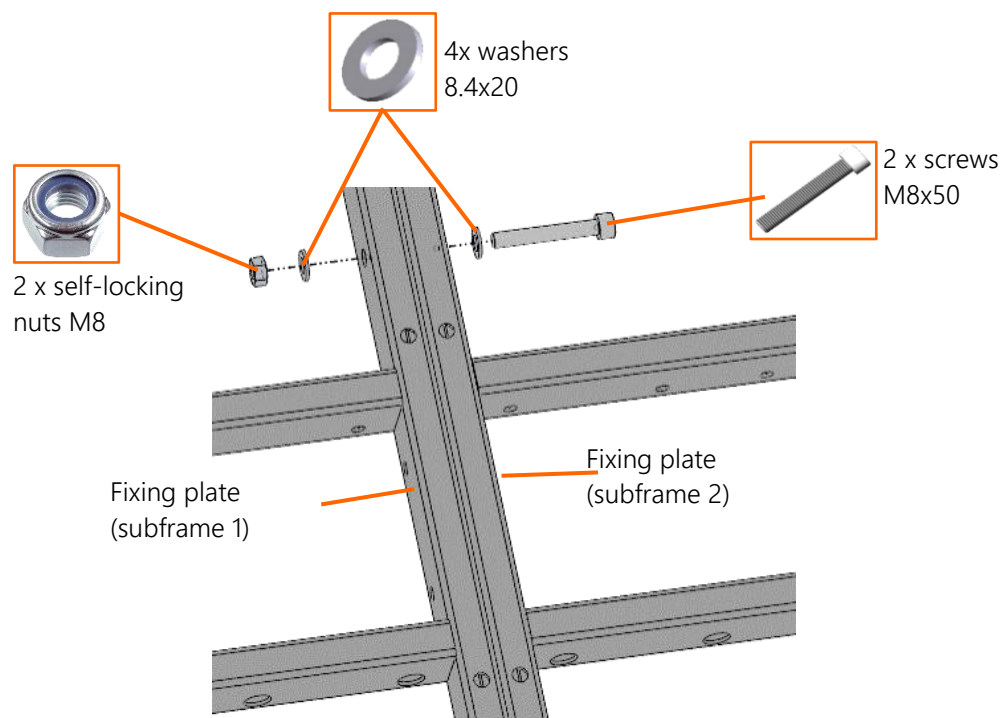

Figure 29 Connection set of the HD 4-leg system

Place the fixing plates of the two subframes exactly next to one another and screw the two fixing plates tightly to one another with the M8x50 screws, the M8 washers and the self-locking M8 nut supplied. Use a size 6 Allen wrench for mounting the screws and a size SW17 open-end wrench for the self-locking nuts.

Check the mounting screws of the connection set HD to ensure that the two fixing plates are fixed tightly to one another. Take care not to over-tighten the mounting screws (recommended tightening torque: max. 10 Nm).

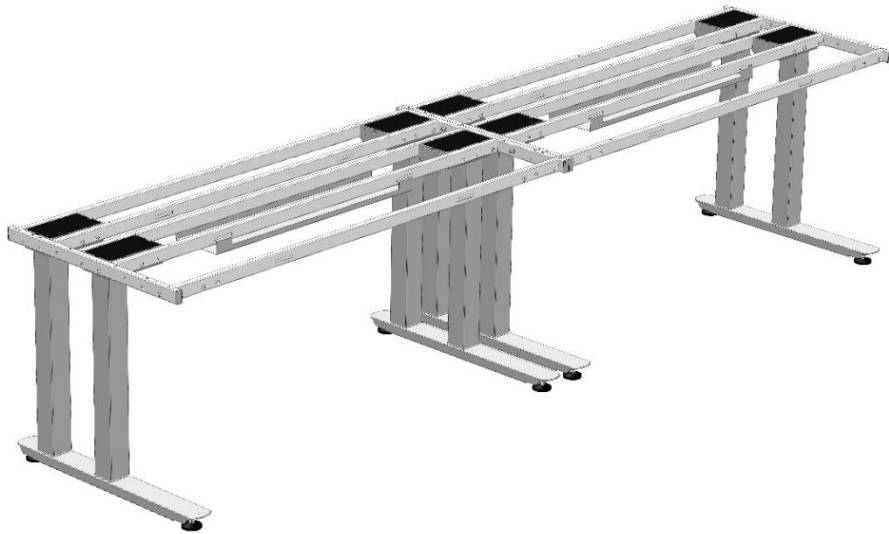

Figure 30 Connection set of the HD 4-leg system: connected subframes

Optional: Mounting the extension set HD

The extension set HD enables connection of commercially available extension elements (e.g. aluminum profiles, holding rails, trays, perforated tabletops) to the rear side on the frame of the ELS3 HeavyDuty subframe.

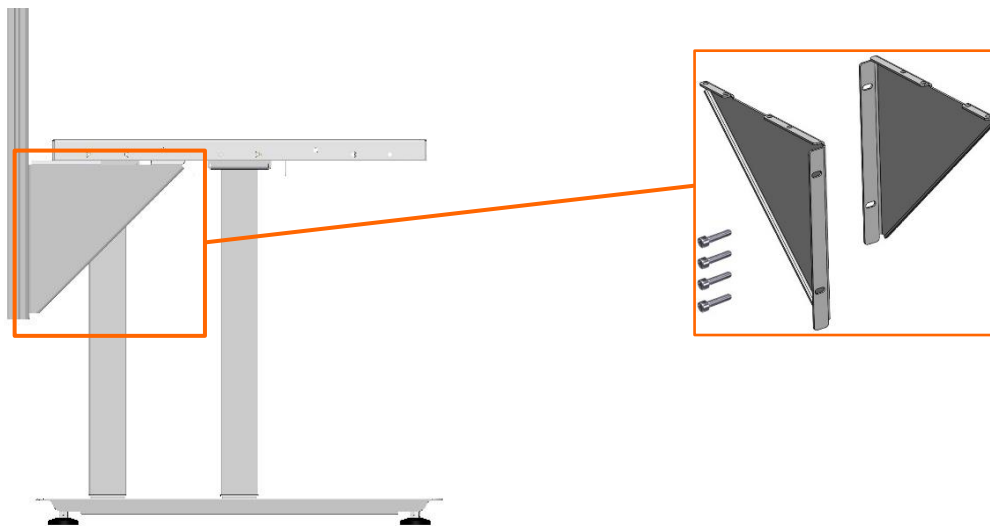

Figure 31 Extension set of the HD 4-leg system

In the process, you have to consider that additional loads attached to the rear side does not cause any risk of tipping over for the HeavyDuty subframe and the max. permissible load of every individual HeavyDuty subframe is complied with.

Mounting accessories for mounting the customized tabletop

IMPORTANT The tabletop is not available in the SUSPA scope of supply since this is freely selectable by the customer depending on the application and design requirement.

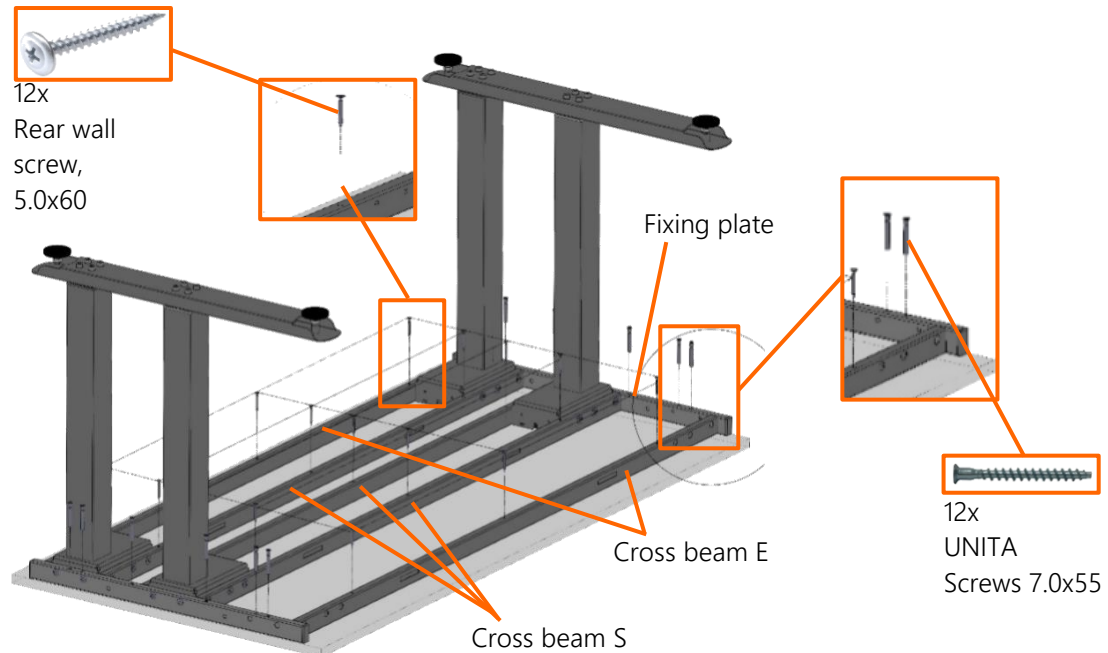

Figure 32 Mounting the tabletop (not included in the scope of supply) on the 4-leg HeavyDuty subframe

- With the customer's selection of the tabletop dimensions, you have to note that the projection of the tabletop borders to the HeavyDuty subframe is only 10 cm maximum, since otherwise there is a great risk of tipping over on load application.
- For mounting the tabletop provided by the customer, the 4-leg system is placed with the HeavyDuty subframe on the tabletop (not included in the scope of supply by SUSPA). The system can be mounted on the tabletop with the help of the screws supplied along with the remaining items in the scope of supply.
- You can use the rear wall screws (5.0x60) to mount the tabletop on the cross beams S and the cross beams E. The fixing plates can be mounted with the UNITA screws (7.0x55) to the tabletop.
- You have to first drill suitable bore holes in the tabletop before you can insert these mounting screws. The diameter of the preliminary drilling depend on the tabletop material used by the customer.
- You can insert the rear wall screws and the UNITA screws with the help of screwdriver or a battery-operated screwdriver.

IMPORTANT Take care to ensure that the work surface is not put down too abruptly in order to avoid damaging the lifting elements.

6.3.3 Mounting the Electrical Controller

IMPORTANT Ensure sufficient cable length for the lifting elements when positioning the electrical controller. The mounting material needed for this is individual and not included in the scope of delivery.

- Mount the electrical controller with four suitable screws at an appropriate position to the work surface.
- When attaching, insert metal washers between the screws and the electrical controller to prevent damage to the controller housing.



Figure 33 Mounting the electrical controller (Screw connection: left 3x, right 1x)

- If it is not possible to mount the electrical controller on the bottom side of the tabletop, the controller may be mounted in the cable tray as an alternative. In doing so, the controller is placed in the cable tray hooked in between the cross beams S and the lifting elements are connected to the controller.



Figure 34 Controller in the cable tray hooked in the 2-leg table system



Figure 35 Controller in the cable tray hooked in the 4-leg table system

- ➔ Do not mount / operate the controller:
 - above or in front of heat sources (e.g. radiators),
 - at locations exposed to direct incidence of sunlight,
 - at or near easily inflammable materials or
 - near high-frequency equipment (e.g. transmitters, radiation equipment or similar devices).
- ➔ Make sure that connecting cables do not have kinks or are not exposed to mechanical stress.

IMPORTANT For protection against over-voltage that may occur during thunderstorms, it is recommended that you install over-voltage protection. Get advice from an electrical installation engineer.

IMPORTANT Observe and follow the aspects given below in the course of installation:

- Select a centralized installation location. Empirical values have demonstrated that this offers the easiest option for the cabling.
- Fit the controller tightly with screws as described in Figure 33 Mounting the electrical controller. Or place the controller in the cable tray supplied if it not possible to mount it on the tabletop. In this way, you avoid malfunctions caused by loose plug-in connections or undesirable noise development.
- During installation, make sure that the controller is freely accessible even after installation. This enables ease of working in case you need to do service work.
- Ensure that there is adequate air circulation during installation. There is, in fact, little heat developed by the controller, but nonetheless, it exists.

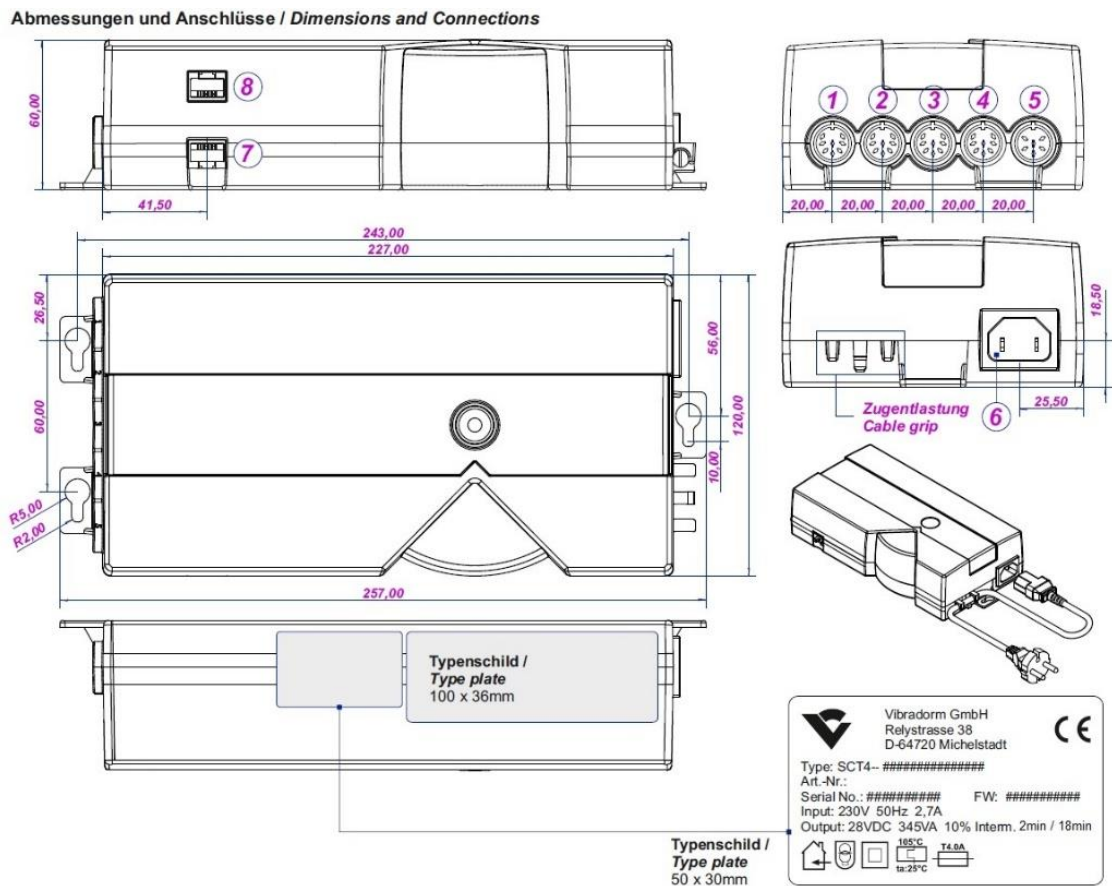

Figure 36 Electrical controller dimensions-connections

6.3.4 Mounting the Manual Switch

- Fasten the manual switch to an appropriate position below the work surfaces.

IMPORTANT Ensure sufficient cable length for the electrical controller when positioning the manual switch.

- Mount the manual switch with two screws to the work surface.
- When attaching, insert metal washers between the screws and the manual switch to prevent damage to the controller housing.



Figure 37 Mounting the simple manual switch UBM-F/2-p

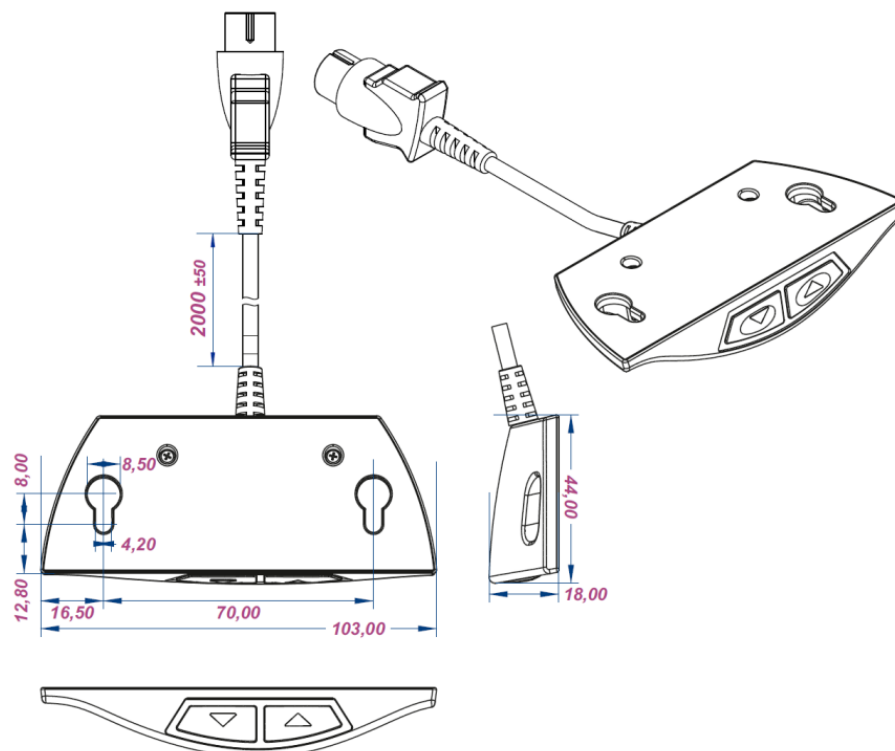

Figure 38 Dimensions of the simple manual switch UBM-F/2-p



Figure 39 Mounting of the programmable manual switch UBS/6-LCD

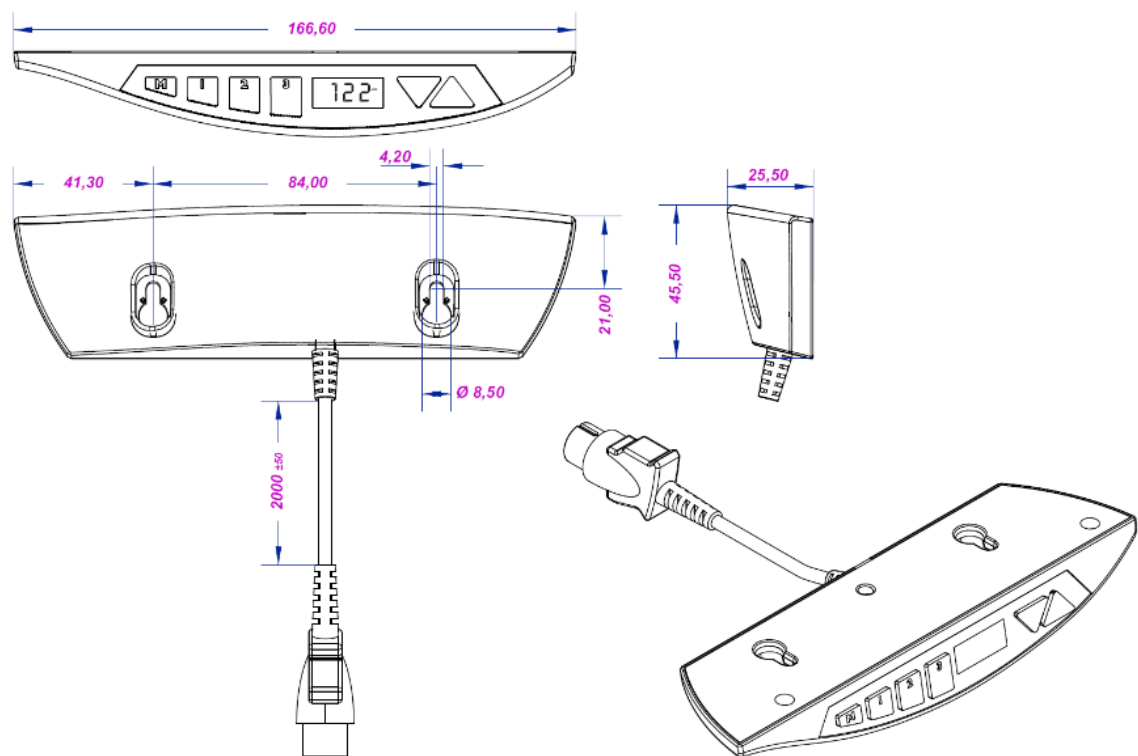

Figure 40 Dimensions of the programmable manual switch UBS/6-LCD

6.3.5 Overall Installation

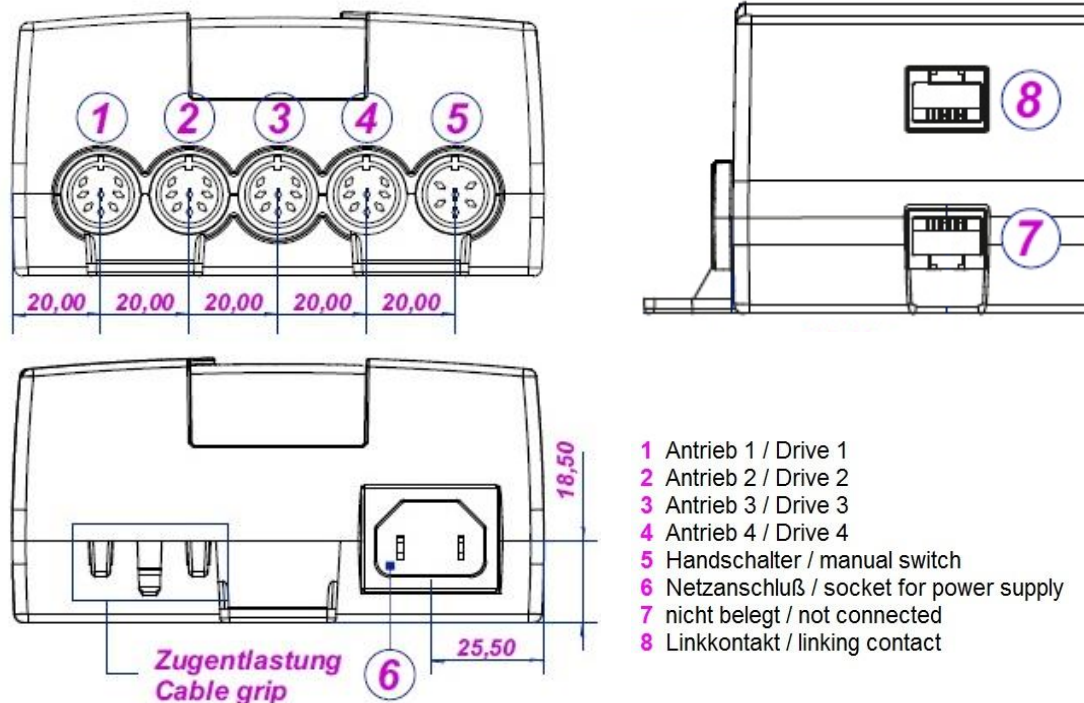

Figure 41 Connections of the electrical controller

- ➔ Connect the plug of the manual switch to the electrical controller using the appropriate input (Figure 41 Terminal No. 5)
- ➔ Connect the plug of the lifting elements to the electrical controller (Figure 41 Terminal No. 1-4)
- ➔ Connect the power cord to the appropriate input of the electrical controller (Figure 41 Terminal No. 6)

IMPORTANT The ELS3 HeavyDuty Height Adjustment System can be supplied in different versions. The supply variants contain 1 to 8 lifting elements. There is a different controller variant depending on the supply variant. The correct variant of the controller can be supplied only if you specify the supply variant at the time of placing the order.

If more than four lifting elements are used in a Height Adjustment System, then the two electrical controllers must be connected to the connector contacts with a link cable (order number: 198 10134) (Figure 41: Connection no. 8). There is no contact made with connection no. 7 and thus, it remains open.

⚠ CAUTION Two controllers are necessary if you are using more than four lifting elements in one Height Adjustment System. The power connector of the two controllers must be joined via a connector strip or via a distribution system provided by the customer. After the power connectors have been connected, they must be coupled to the power source (Socket).

- ➡ Never connect the two controller power connectors separately to the power supply (Socket).

6.3.6 Laying Electric Wires and Cables

- ➡ When laying the cables, make sure that
 - they cannot get jammed
 - they are not subjected to mechanical loads or stresses (tension, pressure or bending etc.)
 - they cannot be damaged in any other way
- ➡ Make sure that the electrical lines of each lifting element of the work surface can be laid without putting them under mechanical tension by maintaining the permissible bending radius of 57 mm (single) and 86 mm (multiple). The electrical wires to the lifting elements are each 1.2 m long.
- ➡ Fasten the cables with adequate strain relief and adequate protection against kinks.
- ➡ The cable tray available in the scope of supply is hooked in between the cross beams S and can be used as stowage space for the excessive electrical wires and cables.
- ➡ Wind the excess length of cables together in rolls with a diameter of approx. 150 mm and fasten them with the fastening clamps and/or cable ties to the work surface.
- ➡ Use caution so as not to damage the wires.
- ➡ Check the electrical lines and cables to ensure that they are fastened securely to the work surface and have not been damaged during the operation.



Figure 42 Coiling of electric wires and cables

6.4 Space Requirements

For detailed information on space requirements refer to the Section 4.1 "Technical specifications".

6.5 Component Alignment

A level will be required to ensure the entire work surface is horizontal and level.

- Place a spirit level on the surface of the work surface.
- Ensure a very uniform load distribution when using several lifting elements.

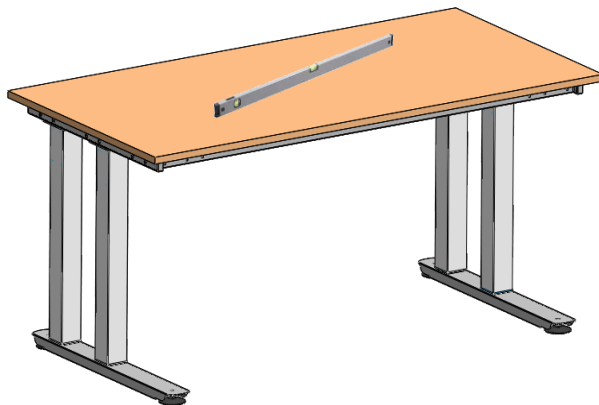

Figure 43 Adjusting the work surface with a spirit level

- By partially unscrewing the leveling feet from the foot base, adjust the individual leveling feet such that the working surface is leveled and all attached lifting elements have uniform contact with the ground. You can do this by unscrewing the leveling foot threaded bolt at the hex. SW17 size nut (for this purpose, also see Figure 44).

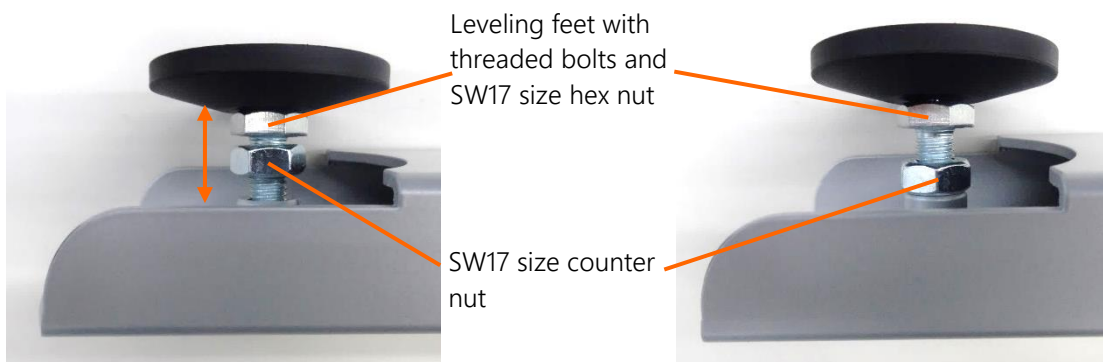

Figure 44 Adjusting the work surface with a spirit level

- ➔ If the level on all leveling feet is adjusted and all leveling feet have uniform contact with the floor, tighten the counter nuts on all leveling feet (also refer to Figure 44 for this purpose), in order to ensure that the work surface remains leveled during operation.

IMPORTANT You can identify whether the table system is adequately leveled and all leveling feet make contact with the floor if the table system is stable and does not wobble.

IMPORTANT One indicator of a uniform load distribution during operation of the Height Adjustment System is that all the lifting elements in the area of drive units (motor / cable outlet) have the same temperature.

7 Operation

7.1 Warning Notices for Operation



WARNING

Crushing or amputation risk due to moving parts

There are risks posed by removing components of the protective housing.

Do not operate the Height Adjustment System if the protective housing of the components has been removed.

IMPORTANT Do not allow the electrical Height Adjustment System to be operated by children. If the device is used near children, ensure supervision by adults and activate the Childproof lock (see Section 7.6.1).

7.2 Tests Prior to Switching the Machine On

- Check all electrical and mechanical connections.
- Check whether there are damages to electrical wires which may have occurred during unpacking or installing of the system.
- Check all system components in order to ensure that they are fastened securely to the work surface.
- Make sure that the maximum load is not exceeded. The maximum load is the entire load including the raised work surface and all objects that are located on the working surface.
- Connect the work surface to the power supply only after checking the above-mentioned aspects.
- Allow the controller to adjust to the change from cold to hot environments for a few hours before putting them into operation, otherwise condensed water may damage them.

7.3 Duty Cycle

The duty cycle refers to the time period in which a motor or system is in motion, compared with the rest period.

The Height Adjustment System is not designed for continuous operation without rest periods. It is designed for intermittent use and has a maximum 10% duty cycle. This means that after operating the Height Adjustment System for two minutes, you must let it rest for 18 minutes before it can be reused. It should be noted that the maximum period of use of the system is two minutes. The limited duty cycle of 10% is stored as a security measure in the electrical controller system.



CAUTION

Danger due to thermal energy

The motor housing may become hot if the operating time exceeds the duty cycle.

The duty cycle must not be exceeded in order not to damage the system. Exceeding the duty cycle on a regular basis, can lead to system malfunction or damage to the lifting element motor(s) and/or electrical controller. Moreover, this could also result in the premature wear of single components, thereby reducing the lifetime of the Height Adjustment System.

Ensure adequate ventilation to ensure sufficient heat dissipation from the components of the Height Adjustment System and do not exceed the duty cycle.

7.4 Manual Switch

All functions of the Height Adjustment System can be controlled using the manual switch.



Figure 45 Simple manual switch UBM-F/2-p



Figure 46 Programmable manual switch UBS/6-LCD (optional)

7.4.1 Function of the Manual Switch

7.4.1.1 Simple Manual Switch UBM-F/2-p





Symbol	Function
	<p>Up:</p> <p>Press the "Up" button until the work surface has reached the desired height or the maximum height.</p>
	<p>Down:</p> <p>Press the "Down" button until the work surface has reached the desired height or the minimum height.</p>
 + 	<p>Reset:</p> <p>Press both direction keys simultaneously. The work surface moves gradually to the lower mechanical end stop. The controller acknowledges this reset drive with a signal tone.</p>

Table 18 Function of the simple manual switch UBM-F/2-p

7.4.1.2 Programmable Manual Switch UBS/6-LCD (Optional)



Symbol	Function
	<p>Up:</p> <p>Press the "Up" button until the work surface has reached the desired height or the maximum height.</p>
	<p>Down:</p> <p>Press the "Down" button until the work surface has reached the desired height or the minimum height.</p>
	<p>Reset:</p> <p>Press both direction keys simultaneously. The work surface moves gradually to the lower mechanical end stop. The controller acknowledges this reset drive with a signal tone.</p>
Key "M"	<p>Memory button for storing the memory positions. Optionally you can also change the upper and lower lifting limits via the setting mode.</p>
Keys "1", "2" and "3"	<p>Up to three memory positions can be stored. To reach the memory position press and hold the respective key.</p>

Table 19 Function of the programmable manual switch UBS/6-LCD

Storing the memory positions:

Move to the desired position and press the "M" key three times and then press the Key 1, 2 or 3. The controller acknowledges the successful storage of the position with a signal tone. The memory position is retained even after a power failure.

Repeat the procedure described to store new memory positions.

7.5 Perform Reset

A reset must be performed both during the initial start-up and upon a power failure during the process. This is used to protect the work surface. Proceed as follows:

- ➔ On the manual switch, press both direction keys simultaneously.
- ➔ The workstation moves at a slow speed until the lower mechanical end stop on the lifting elements is reached.
- ➔ The controller acknowledges this reset drive with a signal tone.
- ➔ The work surface can now be moved with the two direction buttons on the manual switch.

IMPORTANT If the Height Adjustment System does not function immediately, disconnect power from the unit and contact the authorized dealer.

IMPORTANT Do not disassemble the system components (e.g. the electrical controller, switches, ...), except when you have been authorized by SUSPA GmbH to do so. Any attempt to repair the system or the system components without the authorization of SUSPA GmbH will void the warranty.

7.6 Faults and Error Indications



WARNING

Risk of hand injury due to non-observance of the danger zone

There are risks of injuries resulting from improper conduct. Never remove wedged parts or foreign bodies with your bare hands.

Use suitable aids.

7.6.1 Fault and Operational Messages

7.6.1.1 Manual Switch Error Messages

All errors are displayed on the manual switch with fault or operating messages as error codes.

3-digit LCD (programmable manual switch)	Signal tone (simple manual switch)	Meaning
A64	Continuous during operation command	Compulsory reset block run must be carried out
A65	2x	Childproof lock is active
AC9	1x	Time limit restriction has been achieved (2 min / 10% operation; 18 min / 90% break)
AD7	10x	Overcurrent / short circuit of the lifting elements
A6F		Drive monitor pulse difference (load differences) of the lifting elements is too large

Table 20 Error and status codes

7.6.1.2 Important Display Codes and their Meanings

Compulsory reset

The Height Adjustment System is not properly initialized during startup or is disconnected from the main power during the run or the difference in height of the lifting elements is too large due to improper operation.

Indicator: Drive commands are rejected during a keystroke with signal tone, error code A64 in manual switch display.

Solution: Ensure correct connection of the lifting elements and the power grid cable to the controller, check whether the mechanism is not too stiff or jammed.

Perform reset drive (block drive):

Press both direction keys and hold, until the drive arrives at the lower mechanical end position. (Controller acknowledges successful reset with signal tone).

Childproof lock is active

Childproof lock is activated by holding the "M" key for 10s.

Indicator: Drive commands are acknowledged with dual tone and not implemented, error code A65 in manual switch display.

Solution: Childproof lock is deactivated by holding the "M" key for 10s.

Drive monitoring

Difference between the synchronously controlled drives is too large.

Indicator: Drive commands are not implemented, error code A6F in manual switch with display (LCD).

Solution: Check connection of the lifting elements and verify and ensure their correct function. Then perform reset.

Connection error

Manual switches, motors or power plugs are not correctly connected to the controller.

Indicator: Diverse symptoms

Solution: Check the correct connection of the components, make sure that all connectors are firmly plugged into the corresponding sockets!

7.6.2 Troubleshooting

This section contains remedial measures in case of malfunctions. If an error or fault occurs that is not listed in this table, please contact your supplier.

The listing below handles problems that are caused directly in connection with the controller.

CAUTION The troubleshooting and fault rectification should be done only by a specialist who has completed his professional education as an electro-mechanical installation engineer or an equivalent qualification. Make note of the user groups in section 2.5.3.

IMPORTANT Pay attention to the initialization (reset movement) in section 7.5.

	Manual switch with status LED and / or display	Manual switch without status LED and / or display
1. The controller is not working; General Testing	<p>If nothing is output on the display and / or the status LED does not light up when pressing a button, check:</p> <ul style="list-style-type: none"> whether the power cable is plugged in properly into the controller whether the power cable is plugged in properly into the socket whether the socket is supplying power or is switched on Replace the manual switch in order to ensure that the manual switch is not defective Notify your service partner if the controller is still not working. 	<p>Check:</p> <ul style="list-style-type: none"> whether the power cable is plugged in properly into the controller whether the power cable is plugged in properly into the socket whether the socket is supplying power or is switched on Replace the manual switch in order to ensure that the manual switch is not defective If the error persists, continue with step 2.
2. The controller is not working, but no acoustic signal is heard (beep tone)	<ul style="list-style-type: none"> Initialize the controller. Notify your service partner if the controller is still not working. 	
2. The controller is not working, but no acoustic signal is heard (beep tone)	<p>If the table has been moved previously for more than 2 minutes:</p> <ul style="list-style-type: none"> Wait for 18 minutes and try again (switch-on period exceeded) <p>If the table has not been moved previously:</p> <ul style="list-style-type: none"> Initialize the controller. Notify your service partner if the controller is still not working. 	
4. The table moves briefly and then comes to a standstill	<ul style="list-style-type: none"> Initialize the controller. Notify your service partner if the controller is still not working. 	
5. The table is moving at a slant	<ul style="list-style-type: none"> Initialize the controller. Check the load on the table if the fault persists. Initialize the controller once more. Notify your service partner if the controller is still not working. 	

Table 21 Troubleshooting

7.6.2.1 Malfunctions in the Cycle Procedure

- Operation is interrupted
- The type of malfunction is displayed on the manual switch
- The fault must be rectified
- ➔ Please contact the professional personnel when the malfunction is not rectified without additional assistance.

8 Service and Maintenance

8.1 General

- Observe and follow the general accident prevention guidelines.
- Carry out prescribed adjustment, maintenance, and upkeep work according to schedule.
- Replace defective components as quickly as possible.
- Only use tools that are in perfect condition.
- Keep suitable containers ready for small parts that may have to be disassembled.
- Only use original spare parts approved by the manufacturer.
- Tighten screw connections that have been loosened after doing maintenance and service work.
- Reattach disassembled protective devices before the first re-commissioning. Make sure that the protective equipment is functioning properly.
- Perform a functional test (test run) after maintenance or repair work.
- Check the proper function of all safety and protective devices.
- Remove any used tools, screws, aids or other objects from the operational area of the Height Adjustment System including the HeavyDuty subframe.

8.2 Instructions for Maintenance

8.2.1 Cleaning



WARNING

Danger of injury by disregarding the manufacturer's instructions

The function of the components may be impaired as a result of ignoring the manufacturer's cleaning instructions.

Follow all applicable environmental regulations when cleaning.

- Remove all cleaning aids after performing cleaning work.
- Retract the Height Adjustment System before cleaning.
- Remove the load from all lifting elements before maintenance works.
- Unplug the motor control from the mains before cleaning.
- Stabilize the work surface or the HeavyDuty subframe on which the Height Adjustment System is secured before maintenance works.
- Allow the components to cool off before cleaning.
- Clean the system components with a mild detergent and a damp cloth.
- Liquid entry of any kind must be strictly avoided.
- Do not use any corrosive detergents or high pressure washing systems to clean the components of the Height Adjustment System.
- Before restarting operation make sure the system is clean and dry.

8.3 Maintenance

The Height Adjustment System and the HeavyDuty subframe should be checked regularly to determine whether there are conditions that lead to excessive wear or damage to components. Especially the following possible causes of system failure should be considered.

IMPORTANT The maintenance instructions given in the following must be understood as recommendations by the manufacturer. The operator of the Height Adjustment System and the HeavyDuty subframe is obligated to document maintenance-related observations and to supplement and add specifications to the maintenance list in these installation instructions on their own. In addition, the maintenance instructions of the manufacturers of outsourced parts must be observed and followed!

8.3.1 Changing Load Conditions

- ➔ Correct the overload conditions immediately and also make sure that there is even load distribution on the work surface in order to avoid premature wear of the mechanical components.
- ➔ During the further operation note that the system remains balanced and that the mounted lifting elements have uniform contact with the ground.

IMPORTANT One indicator of a uniform load distribution is that all the lifting elements in the area of drive units (motor / cable outlet) have the same temperature.

8.3.2 Contamination

No sterile cleanliness is necessary, but regular cleaning will prolong the life of the system. Dust and dirt can cause wear in moving components, such as shafts and bearings. Therefore, efforts should be made to keep the components clean during the entire operating period.

8.3.3 Damages to Electrical Wires

Check the insulation of the electrical wires for visible signs of aging and wear. Replace defective or damaged wiring.

9 Decommissioning

9.1 Component Storage

The storage area should be cool and dry in order to prevent corrosion of the parts of the Height Adjustment System and the HeavyDuty subframe.

- Pack the parts of the Height Adjustment System including the HeavyDuty subframe in such a way that they are protected from damage by external influences during storage.
- If necessary, use cardboard boxes and other packaging material.
- Secure the parts of the Height Adjustment System including the HeavyDuty subframe against accidental tilting and instability.

Transport and storage conditions	
Temperature:	-25 °C to +60 °C
Rel. Moisture:	10% to 95% (non-condensing)
Air pressure:	106 kPa to 70 kPa

Table 22 Transport and storage conditions

9.2 Disposal of Components

- Dispose of the packaging material in accordance with national regulations.
- Dispose of cardboard packaging, protective packaging made of plastics and preserving agents separately and professionally.

The users are obliged to return the old equipment to a returns center for old electrical and electronic equipment.

The disposal of the controller is subject to the Elektro-G (Electrical Equipment Act), the EC Directive 2002/95/EC internationally (RoHS with effect from 7/1/2006) or the respective national legislation. The disposal of the components (also operating materials) in other countries should be performed in accordance with the local disposal regulations and environmental protection laws in the country where the machine is used.

If the equipment has reached the end of its life cycle, ensure a safe and professional disposal when dismantling, in particular for those parts or substances which are hazardous for the environment. This includes lubricants, plastics and batteries etc.

- Have the machine disposed of properly by an authorized specialist company on account of the potential risk of environmental pollution.

10 Appendix

10.1 Index of Tables

Table 1 Signal words and signal colors	5
Table 2 Symbols.....	6
Table 3 Warning	6
Table 4 Components SUSPA ELS3-500-HeavyDuty system; 2-leg Height Adjustment System	7
Table 5 Components SUSPA ELS3-500-HeavyDuty system; 4-leg Height Adjustment System	7
Table 6 Components of HeavyDuty subframe; 2-leg Height Adjustment System	8
Table 7 Components of HeavyDuty subframe; 4-leg Height Adjustment System	9
Table 8 Target group	13
Table 9 Technical Specifications.....	17
Table 10 HeavyDuty subframe technical specifications.....	19
Table 11: Technical specifications of extension foot (Base)	19
Table 12 Scope of supply for a 2-leg Height Adjustment System.....	25
Table 13 Scope of supply for a 2-leg HeavyDuty subframe	25
Table 14 Scope of supply for a 4-leg Height Adjustment System.....	26
Table 15 Scope of supply for a 4-leg HeavyDuty subframe	26
Table 16 Operating conditions.....	27
Table 17 Lighting requirements	28
Table 18 Function of the simple manual switch UBM-F/2-p.....	57
Table 19 Function of the programmable manual switch UBS/6-LCD.....	58
Table 20 Error and status codes.....	60
Table 21 Troubleshooting	62
Table 22 Transport and storage conditions.....	67

10.2 Index of Figures

Figure 1: 2-leg HeavyDuty subframe	18
Figure 2: 4-leg HeavyDuty subframe	18
Figure 3 Electrical controller SMS SCT4.....	20
Figure 4 Electrical lifting element	20
Figure 5 Simple manual switch UBM-F/2-p.....	20
Figure 6 Programmable manual switch UBS/6-LCD (optional).....	20
Figure 7: 2-leg HeavyDuty subframe.....	21
Figure 8: 4-leg HeavyDuty subframe	21
Figure 9 Packaging	30
Figure 10 Scope of supply for mounting accessories	31
Figure 11 Assembling the top frame of the 2-leg system.....	32
Figure 12 Assembled top frame of the 2-leg system.....	32
Figure 13 Assembly of lifting elements of the 2-leg system with top frame	33
Figure 14 Size 5 Allen wrench	33
Figure 15 Assembling the foot bases of the 2-leg system	34
Figure 16 Mounting the cover plugs of the 2-leg system	35
Figure 17 Cable tray hooked into the cross beams S.....	35
Figure 18 Connection set of the HD 2-leg system.....	36
Figure 19 Connection set of the HD 2-leg system: connected subframes	37
Figure 20 Extension set of the HD 2-leg system	37
Figure 21 Mounting the tabletop (not included in the scope of supply) on the 2-leg HeavyDuty subframe	38
Figure 22 Assembling the top frame of the 4-leg system	39
Figure 23 Assembled top frame of the 4-leg system.....	39
Figure 24 Assembly of lifting elements of the 4-leg system with top frame	40
Figure 25 Size 5 Allen wrench.....	40
Figure 26 Assembling the foot bases of the 4-leg system	41
Figure 27 Mounting the cover plugs of the 4-leg system	42
Figure 28 Cable tray hooked into the cross beams S.....	42
Figure 29 Connection set of the HD 4-leg system	43
Figure 30 Connection set of the HD 4-leg system: connected subframes	44
Figure 31 Extension set of the HD 4-leg system.....	44
Figure 32 Mounting the tabletop (not included in the scope of supply) on the 4-leg HeavyDuty subframe	45
Figure 33 Mounting the electrical controller (Screw connection: left 3x, right 1x)	46

Figure 34 Controller in the cable tray hooked in the 2-leg table system.....	47
Figure 35 Controller in the cable tray hooked in the 4-leg table system.....	47
Figure 36 Electrical controller dimensions-connections.....	48
Figure 37 Mounting the simple manual switch UBM-F/2-p.....	49
Figure 38 Dimensions of the simple manual switch UBM-F/2-p.....	49
Figure 39 Mounting of the programmable manual switch UBS/6-LCD.....	50
Figure 40 Dimensions of the programmable manual switch UBS/6-LCD.....	50
Figure 41 Connections of the electrical controller.....	51
Figure 42 Coiling of electric wires and cables.....	52
Figure 43 Adjusting the work surface with a spirit level.....	53
Figure 44 Adjusting the work surface with a spirit level.....	53
Figure 45 Simple manual switch UBM-F/2-p.....	57
Figure 46 Programmable manual switch UBS/6-LCD (optional).....	57

10.3 Incorporation

EC-Declaration of Incorporation

in accordance with Machinery Directive (2006/42/EC)

The manufacturer declares herewith

SUSPA GmbH
 Mühlweg 33
 90518 Altdorf
 GERMANY

that the design of the partly completed machine:

Machine identification: SUSPA ELS3-500-HeavyDuty including 2-leg or 4-leg HeavyDuty subframe

Year of construction: 2018

Designated use: SUSPA ELS3-500-HeavyDuty including 2-leg or 4-leg HeavyDuty subframe is used to adjust the height of table systems

the delivered version is compliant with Directive 2006/42/EC of the European Parliament and of the Council dated 17 May 2006 on machinery, and conforms with the following harmonized standards and normative documents to which this declaration refers:

Applicable directives: EC Machinery Directive (2006/42/EC)
 EC Directive for Electromagnetic Compatibility (2014/30/EU)

Applied harmonized standards of the overall system (HeavyDuty Height Adjustment System including subframe):

1. **DIN EN ISO 12100:2011**
 Safety of machinery – Risk assessment and risk reduction
2. **DIN EN ISO 13849-1:2008**
 Safety of Machinery - Safety-related components of control systems - Part 1: General design guidelines
3. **DIN EN 60335-1:2012 (without functional safety chapters 19.11; 22.46 and Annex R)**
 Safety of electrical appliances for household and similar purposes

Other applied harmonized standards on the ELS3-500-HeavyDuty Height Adjustment System

4. **DIN EN 61000-6-1/-6-2/-6-3/-6-4 (partially)**
 Electromagnetic compatibility (EMC)

The technical documentation for the partly completed machine is available.

We hereby guarantee that the certification procedure has been carried out in accordance with Machinery Directive 2006/42/ EC. The start-up is prohibited until it has been determined that the machine into which the above mentioned partly completed machine is to be installed complies with the provisions of Machinery Directive 2006/42 / EC. This declaration will lose its validity if any modifications are made to the partly completed machine without consultation with us. Any unauthorized modifications in this sense excludes any liability on our part.

Altdorf, dated

9/21/2018



Signature