

DEPTH-LOADING FILTER CARTRIDGES – GTG EPA SERIES

EPA FILTERING PERFORMANCE FOR GAS TURBINES AND COMPRESSORS

CONSTRUCTION / DIMENSIONS

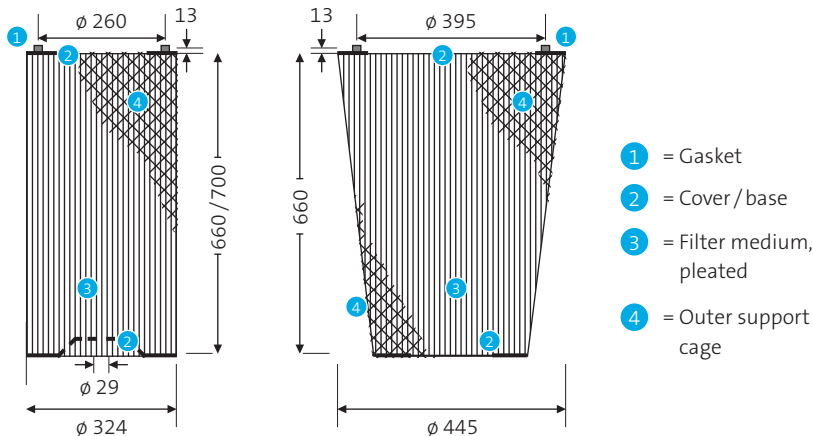

The application

Depth-loading filter cartridges of the GTG EPA (Efficiency Particulate Air) series are used in supply air filtration systems for gas turbines and turbo compressors.

The concept



The GTG EPA depth-loading cartridges with their optimum pressure drop characteristics and maximized useful lifetimes, significantly enhance the cost efficiency of turbomachinery systems.

Utilising EPA filtration virtually eliminates compressor blade fouling which results in stable power output and less turbine maintenance costs. They are particularly successful whenever the cleaning of surface filter cartridges does not produce any effective reduction in pressure drop, because dust concentrations are too low and/or dusts concerned are too sticky.

The characteristics and the benefits

- Innovative high strength synthetic EPA micro-glassfiber media with **water repellent coating and uniform pleat spacing** for maximum dust holding capacity.
- The advanced filter medium offers **efficiencies of class E10 or E12 level, low pressure drop and high cost efficiency**. This makes the GTG EPA cartridges particularly suitable for locations with high fine dust concentrations in the ambient air.
- They have been **optimized in terms of filtering area, pleat depth and number of pleats** which means the active filtering area remains completely effective over its entire operating lifetime.
- The pleat pack, plus the inner and outer support cages are cast into the steel-galvanized or stainless steel end caps in a **leakproof configuration**. The foamed-on EPDM gasket ensures optimum sealing against the mounting plate.
- To further enhance lifetimes a **coalescer or prefilter wrapper** may be fitted depending upon ambient air conditions.
- The product range comprises other cartridge solutions for pulse applications.

TECHNICAL DATA

Cartridge dimension / outer diameter	mm			
		GTG10/12 324-445 W6650 Set	GTG10/12 445 K6650	GTG10/12 324 W6650
Overall height	mm	1,330	660	660
Filter medium		Synthetic micro-glassfiber nonwoven		
Filter area, approx.	m ²	45	25	20
Material for cover, base, support cages		Steel, galvanized		
Gasket		PUR		
Moisture-resistance (rel. hum.)	%	100		
Thermal stability: continuous operation	°C	70		

TECHNICAL FILTER TEST DATA TO EN 779 AND ISO 16890

Pressure drop curves

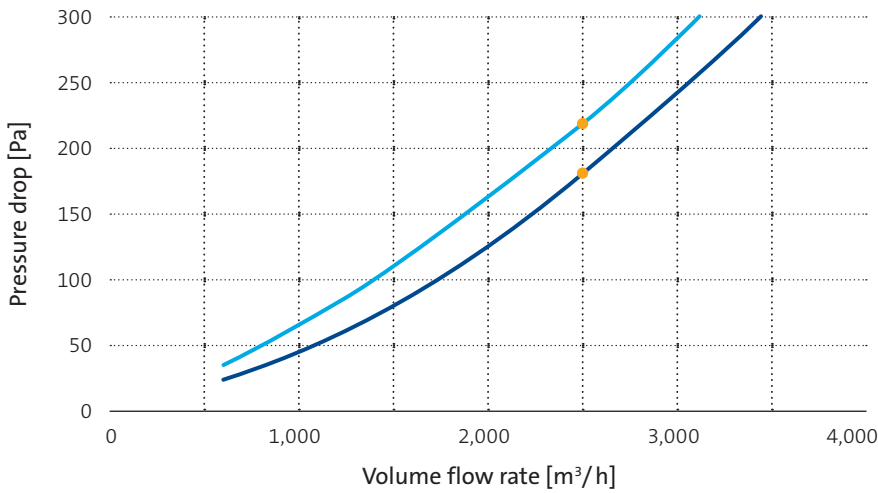

— GTG10 324-445 Set — GTG12 324-445 Set ● Nominal volume flow rate

* Test conditions: Test at nominal volume flow rate, test aerosol: DEHS, test with laser particle counter in test channel according to ISO 16890.

KEY DATA		GTG10 324-445 W66S0 SET	GTG10 445 K66S0	GTG10 324 W66S0	GTG12 324-445 W66S0 SET	GTG12 445 K66S0	GTG12 324 W66S0	
Nominal volume flow rate	m³/h	2,500	1,400	1,100	2,500	1,400	1,100	
Initial pressure drop at nominal volume flow rate	Pa	175	95	130	220	120	150	
Class to ISO 16890	%	ISO ePM1 > 95%				n.a.		
Particulate matter efficiency								
ISO ePM1	%	99				n.a.		
ISO ePM2,5	%	99				n.a.		
ISO ePM10	%	> 99				n.a.		
Cut-off particle size	µm	1				n.a.		
Filter class (EN 1822:2009)		E10				E12		
Initial efficiency for MPPS	%	≥ 85				≥ 99.5		
Max. recomm. operating pressure	Pa					1,500		
Bursting strength	Pa					> 6,000		

e.FFECT

electronic Freudenberg Filter Efficiency Calculation Tool

Discover how efficient your filtration system is and feel free to ask our filtration consultants for an e.FFECT calculation. Using this software tool we can precisely define which filtration solution will best achieve your goals.

The information or figures given are subject to tolerances due to normal production fluctuations. Our explicit written confirmation is required in each case for the correctness of the information. Subject to technical alterations. You will find instructions on how to handle and dispose of loaded filters in our information on product safety and eco-compatibility.

FREUDENBERG FILTRATION TECHNOLOGIES

Contact us

www.freudenberg-filter.com

FREUDENBERG
INNOVATING TOGETHER