

PULSE-JET FILTER CARTRIDGES OF GTS SERIES IN DOUBLE-CYLINDRICAL DESIGN

OPTIMIZED CLEANING PERFORMANCE FOR PULSE-JET SYSTEMS

CONSTRUCTION / DIMENSIONS

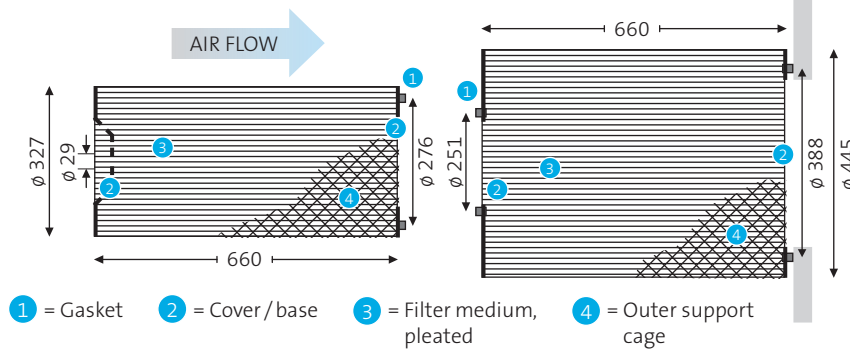

All dimensions given in mm.



The application

Viledon® self-cleaning pulse-jet filter cartridges of GTS series are used in supply air filtration systems for gas turbines and turbo-compressors in both on and offshore applications.

The concept

GTS cartridges with their optimized self-cleaning characteristics, maximize useful lifetimes and minimize particle ingress in turbomachinery systems. They meet the stringent requirements

for clean air quality, particularly under critical on-site conditions like desert areas or tropical climates.

The characteristics and the benefits

- Innovative high-strength synthetic microfiber nonwoven with water-repellent coating that allows the cartridge to maintain excellent operational characteristics in all climatic conditions including high humidity locations.
- The double-cylindrical geometry in combination with flow-optimized pleat spacing results in a particularly low pressure drop and very good cleanability via pulse impulses (especially compared to conventional conical-cylindrical geometries).
- The innovative packaging of pairs of cartridges pushed into each other halves the required storage volume.
- To minimize corrosion and handling damage, the inner and outer support cage and base end caps are made of galvanized steel G90 grade.
- The foamed-on PUR/EPDM gasket ensures optimized sealing against the mounting plate. The two gaskets between small and big cylinders serve as ideal centering aid during installation.
- Other geometries and stainless steel versions available on request.

TECHNICAL DATA

		GTS CARTRIDGE SET (DOUBLE CYLINDRICAL)			GTS SMALL CYLINDRICAL CARTRIDGE		
		GTS 445 E66S0 + GTS 324 Y66S0	GTS M15 445 E66S0 + GTS M15 324 Y66S0	GTS10 445 E66S0 + GTS10 324 W66S0	GTS 324 Y66S0	GTS M15 324 Y66S0	GTS10 324 W66S0
Overall height	mm	1,330			660		
Diameter	mm	327 / 445			327		
Filter medium		Synthetic microfiber nonwoven					
Filter area, approx.	m ²	38	38	34	15		
Material for cover, base, support cages		Steel, galvanized					
Gasket		PUR					
Moisture-resistance (rel. hum.)	%	100					
Thermal stability: continuous operation	°C	70					

TECHNICAL FILTER TEST DATA TO ASHRAE 52.2, EN 779 AND ISO 16890

Fractional collection efficiency curves

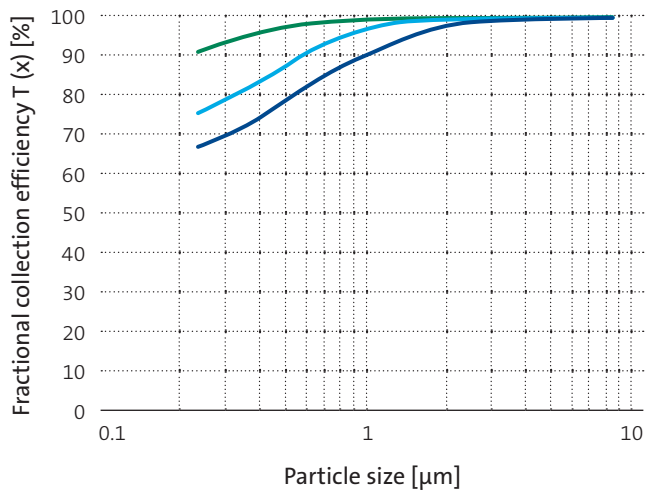

Initial pressure drop curves

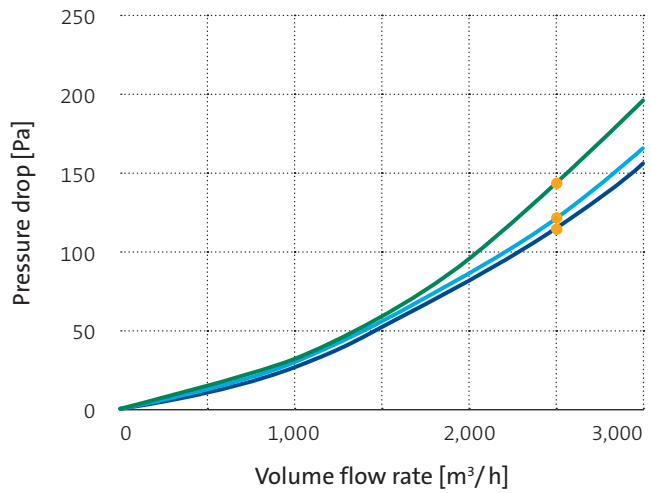

— GTS 445-324 Set — GTS M15 445-324 Set — GTS10 445-324 Set ● Nominal volume flow rate

KEY DATA		GTS CARTRIDGE SET (DOUBLE-CYLINDRICAL)			GTS SMALL CYLINDRICAL CARTRIDGE		
		GTS 445 E6650 + GTS 324 Y6650	GTS M15 445 E6650 + GTS M15 324 Y6650	GTS10 445 E6650 + GTS10 324 W6650	GTS 324 Y6650	GTS M15 324 Y6650	GTS10 324 W6650
Filter class ASHRAE 52.2:2017 EN 779:2012 EN 1822:2009		MERV14 F9 —	MERV15 F9 —	MERV16 — E10	MERV14 F9 —	MERV15 F9 —	MERV16 — E10
Nominal volume flow rate ●	m³/h	2,500			1,100		
Initial pressure drop at nominal volume flow rate	Pa	115	120	140	130	135	150
Class to ISO 16890	-	ISO ePM1 75%	ISO ePM1 85%	ISO ePM1 > 95%	ISO ePM1 75%	ISO ePM1 85%	ISO ePM1 > 95%
Particulate matter efficiency							
ISO ePM1		78	87	97	78	87	97
ISO ePM2,5	%	83	91	98	83	91	98
ISO ePM10		94	97	99	94	97	99
Cut-off particle size	µm	4	2	1	4	2	1
Initial efficiency for MPPS	%	—	—	89	—	—	89
Max. recomm. operating pressure	Pa	1,500					
Bursting strength	Pa	> 6,000					

In most cases, it is possible to change from conical-cylindrical to double-cylindrical cartridges. In this way, they make an **important contribution to sustainable environmental protection** by reducing transport volumes and packaging materials. The innovative packaging of pairs of cartridges pushed into each other **halves the required storage volume**.



The information or figures given are subject to tolerances due to normal production fluctuations. Our explicit written confirmation is required in each case for the correctness of the information. Subject to technical alterations. You will find instructions on how to handle and dispose of loaded filters in our information on product safety and eco-compatibility.

FREUDENBERG FILTRATION TECHNOLOGIES

Contact us

www.freudenberg-filter.com

