

lifgo® & lean SL® 5.0 – 5.3

Instructions for Installation, Commissioning & Maintenance

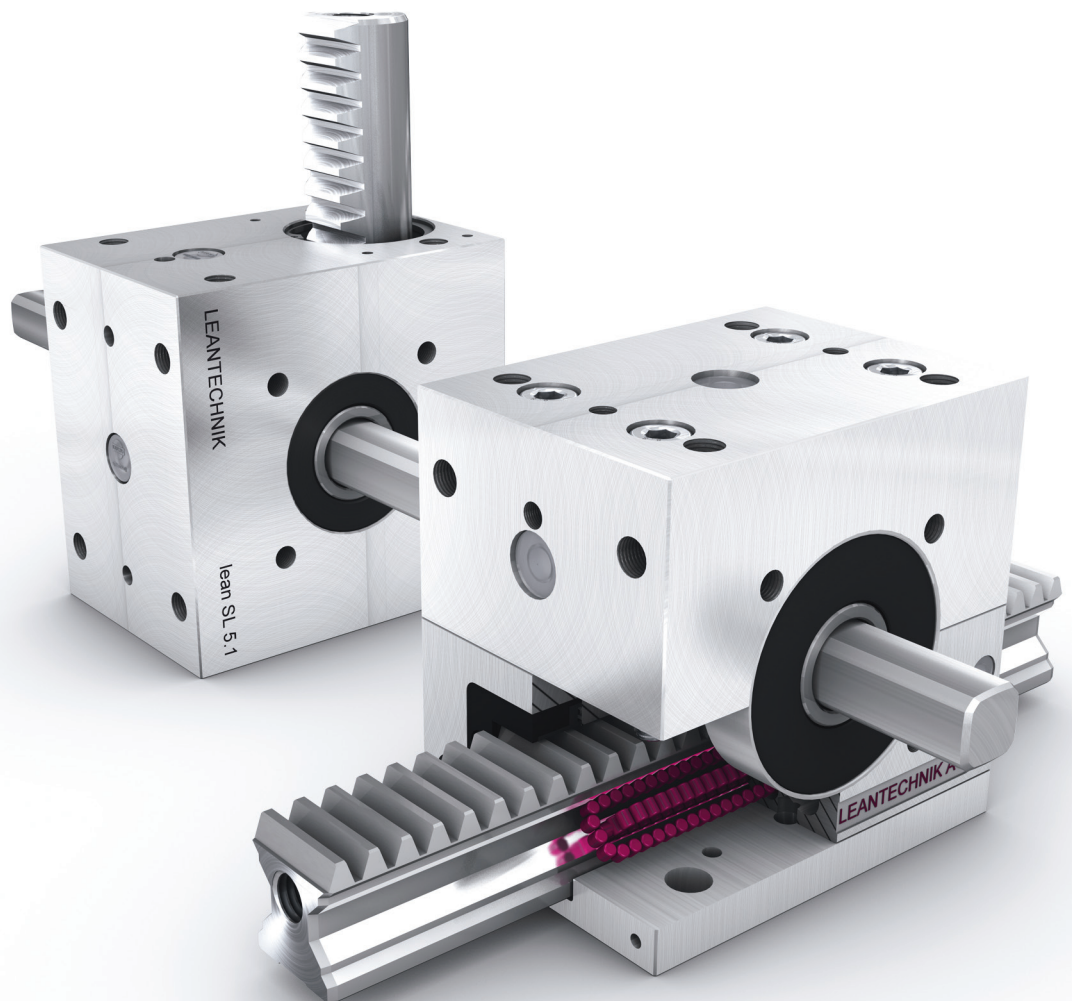

LEANTECHNIK AG

Version 03.2012 / www.leantechnik.com

Important notes on lifter installation

⚠ Note! The shipping lock (assembly aid) must remain in the lifter guide block until it is slid onto the gear rack/guide rail. Otherwise the rollers can be lost.

For this reason, also make sure that there is no air gap between the gear rack/guide rail and the shipping lock when the lifter/guide block is slid on or pulled out.

⚠ Note! Use the shipping lock when the lifter guide block is pulled off of the gear rack/guide rail. The lifter guide block should always remain on the shipping lock when it has been removed.

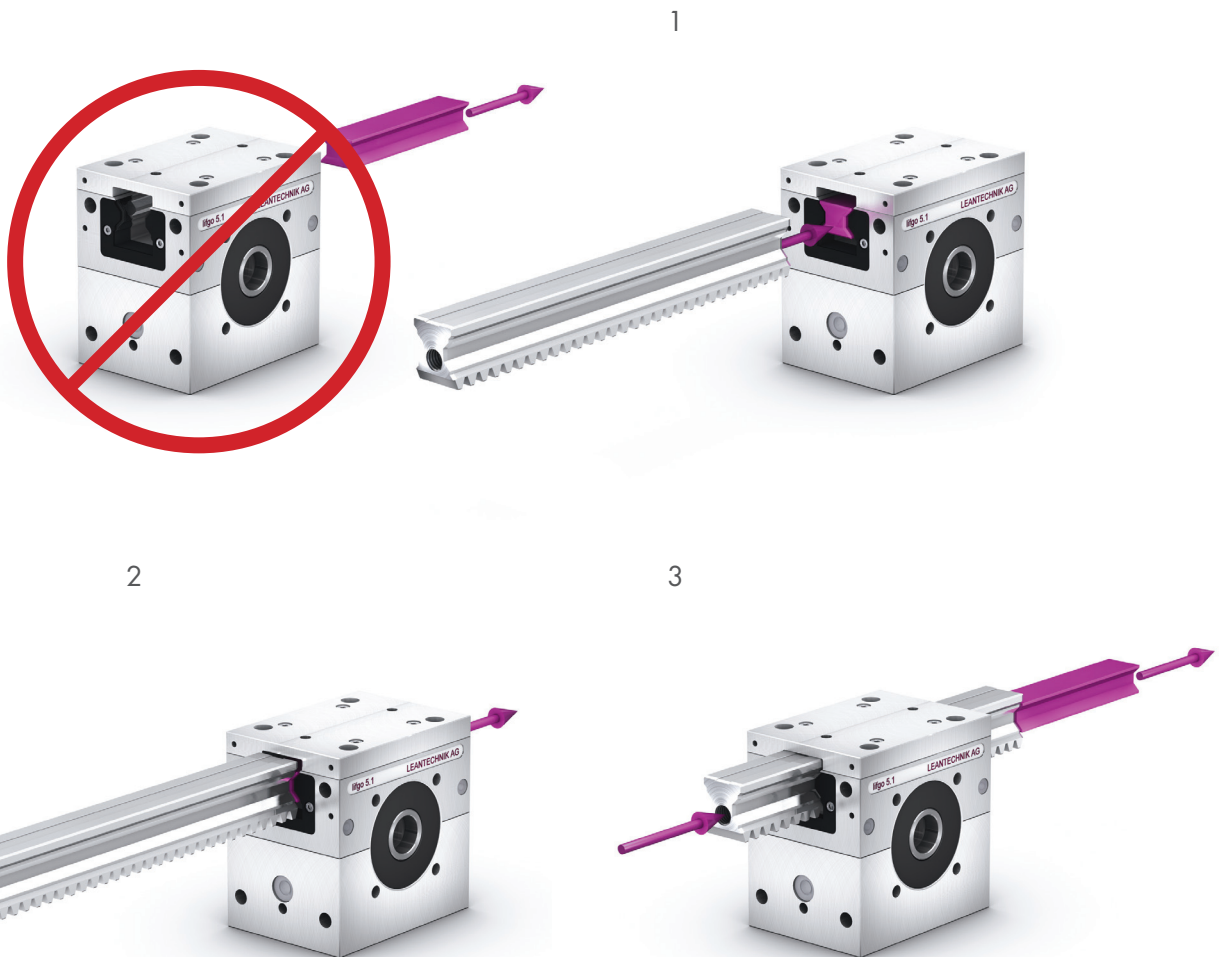

Contents

1	Rules	
1.1	Introduction	4
1.2	Component identification	4
1.3	Contact address	4
1.4	Warranty	4
1.5	Product liability	5
1.6	EU Machine directives	5
1.7	Technical changes/modifications	5
1.8	Symbols used	5
2	Product information	
2.1	Technical data	5
2.2	Proper use	5
2.3	Improper use	5
3	Safety regulations	
3.1	General	6
3.2	Hazardous points	6
3.3	Shipping	7
3.4	Storage	7
3.5	Assembly	7
3.6	Start-up	7
3.7	Servicing	8
3.8	End of service life, removal, disposal	8
3.9	Resale	8
4	Assembly & Commissioning	
4.1	Assembly manual for lifgo® & lean SL®	9
4.2	Commissioning	10
5	Servicing	
5.1	Terminology	11
5.2	Safety	11
5.3	Screw connections	12
5.4	Maintenance – lubrication	12
5.4.1	General notes	12
5.4.2	Relubrication intervals – maintenance lubrication	12
6	Replacement parts	13
7	Instructions for adjusting lifgo® eccentric 5.0 – 5.3	14

1 Rules

1.1 Introduction

This manual describes the installation, operation, and maintenance of the lifgo®, lean SL®, lifgo® eccentric & lifgo® linear eccentric lifter series, in all sizes and models from 5.0 – 5.3. **lifgo® & lean SL®** are units that combine the following components: pinion, gear rack, and guide. **lifgo® eccentric & lifgo® linear eccentric** are units that combine the following components: pinion, gear rack, guide, and eccentric disc.

In order to ensure trouble-free function of the gear rack lift drive over the long term, it is essential that the instructions in this manual are followed throughout all phases of the life of the lifter.

Carefully read this documentation. In case of doubt, contact LEANTECHNIK AG directly.

The manufacturer of lifgo® & lean SL®, lifgo® eccentric & lifgo® linear eccentric is not responsible for damage to the environment, property, or personnel that result from changes or actions that are not consistent with these instructions.

© Reproduction of texts, images, or drawings, in whole or in part, without the written permission of LEANTECHNIK AG, is forbidden. This applies to copying, translating, microfilming, and storing in electronic systems.

1.2 Component identification

The components are referred to in this manual by the terms **lifgo® & lean SL®** and **lifgo® eccentric & lifgo® linear eccentric**. These names should be used, together with the size, for communication and information requests. The components are referred to below as **lifgo® & lean SL®** and **lifgo® eccentric & lifgo® linear eccentric**.

LEANTECHNIK AG is the manufacturer of the lifter series lifgo® & lean SL® and lifgo® eccentric & lifgo® linear eccentric.

1.3 Contact address

LEANTECHNIK AG

Im Lipperfeld 7c
D - 46047 Oberhausen, Germany

Phone ..49 (0) 208 · 495 25 - 0

Fax ..49 (0) 208 · 495 25 -18

E-Mail info@leantechnik.com

www.leantechnik.com

1.4 Warranty

The manufacturer's warranty from LEANTECHNIK AG is 1 year, according to the general terms & conditions (T&C). They are found in separate documentation. The warranty for replacement parts is 12 months after commissioning. Use only original replacement parts from LEANTECHNIK AG when replacing parts, because no liability for material quality, correct dimensions, and proper machining can be provided for replacement parts from other manufacturers.

1.5 Product liability

Product liability for the lifgo® & lean SL® lifters lies with the manufacturer LEANTECHNIK AG. Operational safety and maintenance of lifgo® & lean SL® is first and foremost the responsibility of the operator (a company that uses lifgo® or lean SL® as machine elements). The manufacturer is not liable for damage or injuries arising from improper use of the product.



1.6 EU Machine directives

In the sense of the EU directive for machines 2006/42 EG, a pinion/gear rack/guide combination is not considered an independent machine, but a component to be installed in machines. Commissioning is not permitted until it has been determined that the machine in which this product is installed meets the requirements of the EC directive.

1.7 Technical changes/modifications

LEANTECHNIK AG reserves the right to make technical changes to improve the product. Changes or modifications to lifgo® & lean SL® may be performed only with written permission from LEANTECHNIK AG. Any changes or manipulation are grounds for voiding the warranty.

1.8 Symbols used

1. Warning sign		Warning! or Danger!
2. Notification sign		Important assembly, safety, and functional information

2 Product information

2.1 Technical data

Technical data and weights can be found in our current catalog.

2.2 Proper use

lifgo® & lean SL® are designed and built as lifting, positioning, or pushing elements, and should be used only as such. Application examples and maximum permissible forces can be found in the current LEANTECHNIK AG catalog. In case of doubt, contact the manufacturer.

2.3 Improper use

Uses that deviate from Chapter 2.2 are not permitted. Exceeding the maximum permissible forces and torques for the lifgo® & lean SL® series is also improper.



Note! Other uses of lifgo® & lean SL® are not permitted even in part.

3 Safety regulations

3.1 General

Safety regulations apply to all phases of life of lifgo® & lean SL®. This includes shipping, assembly, service life, maintenance, and disposal. The following points must be observed when using lifgo® & lean SL®.

- All personnel that work with lifgo® & lean SL® must be familiar with the technology. This applies to installation, maintenance, and disassembly.
- Shipping requires great care in order to prevent damage to the lifgo® & lean SL® units.
- All personnel that work with lifgo® & lean SL® must be familiar with this documentation.
- In case of problems with the lifgo® & lean SL® units, the cause must be corrected immediately. If the cause of the problem cannot be found and/or corrected, call a technician or LEANTECHNIK AG for assistance immediately.
- Replacement parts that are not supplied by LEANTECHNIK AG are not permissible, because such parts have not been inspected by the manufacturer, and can therefore negatively affect the reliability of the product.
- The use of replacement parts that are not supplied by LEANTECHNIK AG will result in the voiding the warranty on lifgo® & lean SL® units, because the manufacturer accepts no liability for such replacement parts.
- Lubricating oils, detergents, preservatives, and acids must be collected and disposed of in a legally prescribed manner.



Note! In case of any questions regarding functionality, or problems for which the answer or solution is unknown or cannot be determined, contact the manufacturer. Contact the manufacturer even in cases of doubt.

3.2 Hazardous points

The manufacturer cannot be held liable for property damage and/or personal injury in the following cases, if the lifgo® & lean SL® units:

- have been modified from their original condition.
- have not been installed correctly.
- are not used properly.
- are not properly maintained.
- are installed or maintained by untrained and/or unauthorized persons.

Gear racks should be covered for safety reasons after installing the lifgo® & lean SL® unit.

3.3 Shipping

Shipping lifgo® & lean SL® is noncritical. It is important, however, that the lifgo® & lean SL® series lifters and their associated gear racks are secured relative to each other, or are separated prior to shipping.

The following should be observed when lifting and placing lifgo® & lean SL® units:

- Use only undamaged, approved material and lifting equipment.
- Adjacent parts must be disassembled beforehand. This applies to mechanical, hose, piping, and cable connections. When removing hose or piping connections, care must be taken that no media leak out unchecked. In case of doubt, media should be drained beforehand and captured.
- If lifting cables or slings are used, care must be taken that they do not contact any sensitive parts; otherwise, they may be deformed or destroyed, and their function is then no longer guaranteed.
- Avoid jerking and collisions when lifting and setting in place.



Danger! Do not stand or work under suspended loads. Do not ride along on the load or load-carrying equipment.



All load-carrying components, such as eyebolts, lugs, or cables must be designed for the load to be lifted. The weights of individual components can be found in the technical data. If there is any doubt about suspension points and weights, contact the manufacturer.

3.4 Storage

lifgo® & lean SL® are treated with preservative at the factory. The parts are thereby protected against corrosion for no more than 6 months in a dry environment. The corrosion protection on any unpainted surfaces (sliding surfaces, gear racks) must be inspected, and renewed if necessary, prior to placing in storage. Before using lifgo® & lean SL®, the corrosion protection must be removed and replaced with the lubricant specified in the maintenance manual.

3.5 Assembly (see also Chapter 4)

Before starting the installation, always make sure that all parts have been delivered and are available. All parts must be properly installed. Follow our assembly videos at www.leantechnik.com. We cannot accept responsibility for errors or damage of any kind.

3.6 Start-up

Prior to start-up, lifgo® & lean SL® must be integrated in the overall safety concept. Ensure that all lubrication points have been lubricated as required.



Note! All motions must be performed slowly the first time. The motion should be performed over the entire stroke length. Actuation of any end switches must be checked.

3.7 Servicing

The following points must be observed for maintenance and repairs:

- Keep unauthorized persons out of the maintenance area.
- Removal and installation of components must be performed by technicians.
- Use only suitable tools of the correct size in order to avoid damage to screws, bolts, and nuts.
- Always note the installation orientation of components, and make any notes required for assembly.
- Mounting screws must be properly tightened to the correct torque and secured against unintended loosening.

For further information about maintenance, see the maintenance plan in Chapter 5.

3.8 End of service life, removal, disposal

When removing lifgo® & lean SL®, be sure to follow the rules of environmental protection. This includes separating materials prior to disposal (sort out different metals, plastics, rubber, electronics, etc.) Mechanical parts must be separated from electrical, pneumatic, and hydraulic parts. That is, cable harnesses are removed, motors demounted, hoses removed, fluids captured, etc. All parts that have been lubricated must be cleaned.



Rules and laws regarding disposal of oil and grease must be followed. Companies that perform the disposal are required to present the necessary permit.

3.9 Resale

In case of resale of lifgo® or lean SL® units, all rules of disassembly from Chapter 3.8 must be followed. The buyer must be provided with this documentation in undamaged condition.

4 Assembly & Commissioning

4.1 Assembly manual for lifgo® & lean SL®

(also follow the functional & assembly videos under www.leantechnik.com)

1. **Note: do not remove the shipping lock beforehand.** Insert the gear racks into the lifters that are connected via profile shafts. For lifgo® lifters, push the shipping lock out with the gear rack. No space should remain between the shipping lock and the gear rack/guide rail. **Do not pull out the shipping lock.** Place the gear rack/guide rail in the center and parallel to the lifgo® guide in order to avoid damaging seals and prevent the gear rack from being misaligned during insertion. During insertion, rollers must not fall into the drive or the guide. Slide the gear rack in until just before the pinion shaft, so that the first tooth of the gear rack can engage with the pinion shaft. Draw in the gear racks by rotating the profile shaft **at the same time** (horizontal & vertical), so that the shipping lock falls out the other end of the guide. Move the gear racks to their final position, according to the drawing. Slide on the gear rack protection (if used) and screw on the retaining plate.

lifgo®

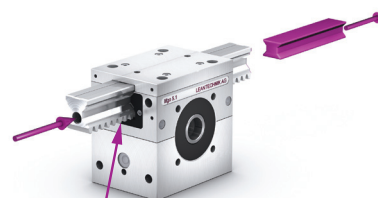
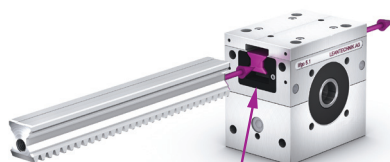

 **pinch point hazard!**

 **pull in hazard!**

lean SL®

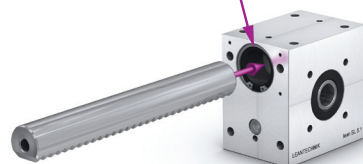

2. Position the lifgo® & lean SL® as required, and screw in place according to the technical drawing/specifications. **Tighten the screws only slightly.**
3. Assemble the universal joints to the profile shafts, if any, according to the drawing (rotational connection). Each individual profile shaft requires two axial retainers to prevent it from moving out to the side. lifgo® & lean SL® are automatically synchronized to each other by the profile shafts. Slide the set collars against the lifgo®/lean SL® housing and tighten their retaining screws. **The profile shafts are now installed, with no axial play.** Connect all lifters with a rotational connection in this manner.
4. Establish the power connection between the drive (air cylinder or gearmotor) by means of the coupling unit or gearbox adapter. Position the first lifgo®/lean SL® behind the drive. All lifgo®/lean SL® units that are connected by profile shafts are also adjusted by this connection. Adjust the gear racks to the same height as the first gear rack behind the drive, by rotating the profile shaft.
5. Install the differential coupling as follows: Obtain dimension "L" from the drawing, or measure it. The DC should correspond to the dimension "L". Thread lengths on the hex rod must be screwed into the clevis to approximately the same depth. The jam nut with retaining rings is threaded on the eyebolt all the way to the end. Screw the eyebolts, with retaining ring and jam nut, into both gear racks to about half their thread length, and jam the nuts to the gear rack

surface. The eyebolt should be oriented vertically to the side wall. Connect the eyebolt/clevis on both sides, using the retaining pin, and press the retaining clip onto the clevis. The hex rod in the middle has a left/right hand thread. Rotating in one direction increases dimension "L", and the other direction decreases it (turnbuckle function). This means: rotating the hex rod raises or lowers the rear row of vertical gear racks. Set them so that the position is set according to the drawing, or to the same height as the front row of gear racks. When the position is reached, jam the nuts against the clevises.



Note! Make sure that the gear rack teeth are aligned in parallel to the pinion teeth when installing the differential coupling.

6. Check that the system runs easily, and tighten all screws completely.
7. Place any planned accessories on the vertical gear racks, and secure by means of the included screws. Check again for smooth operation. Assembly is complete.
8. Keep the shipping lock for the lifgo® gear rack guide. When disassembling the gear racks/guide rails, slide the gear rack out using the shipping lock, so that there is no distance between the lock and the gear rack/guide rail. Also leave the shipping lock in the guide in case of any cleaning or repair work. Perform assembly as described under Item 1.

4.2 Commissioning

lifgo® & lean SL® require initial lubrication. lifgo® has three lubrication points on the housing, and four lubrication points on the guide block. lean SL® has three lubrication points on the housing.

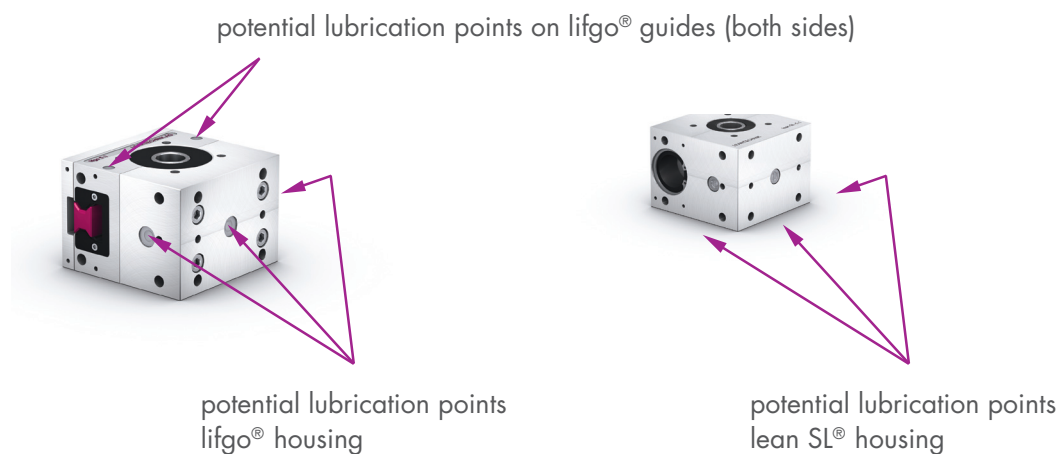

The choice of which lubrication point to use is open. It is important, however, that one lubrication point on each is used. Unused lubrication points must each be securely closed off by a threaded plug. Remove the screw from the lubrication point in use, and screw in the included grease nipple. Press on the protective cap (yellow).

We recommend lithium soap grease without EP additives, lubricating grease type K. Select according to the load. Follow the manufacturer's instructions.

Housing

Lubricating grease – K2K, DIN 51825

for normal loads

Lubricating grease – KP2K, consistency class NLGI 2, DIN 51818

for higher loads

Guide block

Low-viscosity grease – DIN 51826 NLGI 00 or NLGI 000

The lifgo® and lean SL® lifters are provided with light lubrication at the factory. This is sufficient for a test run of 10 strokes. Initial lubrication must be performed prior to commissioning or a test run.

Commissioning lubrication

lifgo® & lean SL®		5.0	5.1	5.3
Quantity of grease	Unit			
lifgo® Guide block	cm ³ – grease	1.9	2.2	6.6
lifgo® housing	cm ³ – grease	7.5	26.6	71.2
lean SL® housing	cm ³ – grease	11.4	26.6	121.4



Perform a test run of 100 strokes with no load. Follow with a maintenance lubrication.



Run the test for a maximum of 10 strokes with no load. Then perform an initial lubrication.

5 Servicing

5.1 Terminology

All actions that have the objective of maintaining and securing the readiness and usability of components are known as servicing. Servicing includes the areas of:

- Care (maintenance, cleaning)
- Inspection (checkup, troubleshooting)
- Repair

Servicing is performed according to prescribed plans.

5.2 Safety



Note! The safety regulations from Section 3 of this documentation apply to all servicing and troubleshooting work.

5.3 Screw connections

After repair work or replacement of parts, no damaged screws, washers, nuts, or pins may be reused. Only standardized parts that meet at least the quality indicated in the parts list may be used. Before parts are installed, the contact surfaces must be thoroughly cleaned. Threaded and through holes must also be free of contamination. Check all screw connections regularly to the torque indicated on the drawings. If there are not drawings, then the following tightening torques should be used:

Tightening torques & preloading forces for metric set screws

(at 90% utilization of the 0.2% strain yield limit (according to DIN EN 20898 Part 2, excerpt). Coarse pitch thread, coefficient of friction μ est. 0.14, screw quality 8.8.

Dimension	Unit	M4	M5	M6	M8	M10	M12	M16	M20
Preloading forces	N	4300	7000	9900	18100	28800	41900	78800	127000
Tightening torques	Nm	3.3	6.5	11.3	27.3	54	93	230	464

0.10: for untreated surfaces, lubricated with molykote

0.14: for untreated surfaces, lightly oiled

5.4 Maintenance – lubrication

5.4.1 General notes

Before reapplying lubrication, the following points must be observed:

- Clean machine parts, such as gear racks, before applying new lubricant.
- Clean contact and sliding surfaces.
- Remove old grease from bushings and guides before applying grease.
- Collect the lubricating oils, detergents, preservatives, and acids, and always dispose of them in the legally prescribed manner.



Note! Properly dispose of old grease. We, as the manufacturer, cannot be held responsible for claims of damages due to environmental damage.



Note! Reapply lubricant immediately after each cleaning. This prevents corrosion.

5.4.2 Relubrication intervals – maintenance lubrication

Maintenance lubrication

Our information is based on typical duty for servo drives, interrupted by rest periods, and continuous lubrication. The values for daily and monthly lubrication cannot be determined by calculation. They are merely recommendations intended to emphasize the importance of good lubrication. Proven solutions for continuous lubrication include automatic lubricating bushings and central lubrication systems. Under environmental conditions such as contamination, the use of lubricating coolants, vibration, or impact loads, we recommend shorter lubrication intervals, and longer intervals for lighter loads. Maintenance lubrication quantities and intervals are shown in the following table:

Maintenance lubrication quantities and intervals for lifters

lifgo® & lean SL®		5.0	5.1	5.3
Quantity of grease	Unit			
lifgo® Guide block, lubrication cartridge 60 cm ³	cm ³ /km	0.0025	0.0030	0.0325
L – operating range	km	24000	20000	1850
lifgo® housing, lubrication cartridge 125 cm ³	cm ³ /km	0.0540	0.0625	0.1223
L – operating range	km	2320	2000	1020
lean SL® housing, lubrication cartridge 125 cm ³	cm ³ /km	0.06	0.07	0.125
L – operating range	km	2080	1780	1000

 Due to unknown local conditions, it is not possible to give a definite recommendation for grease quantities and intervals. Maintenance personnel must pay closer attention to the state of the lubrication at the beginning, and react accordingly.

 An obvious film of lubricant should be visible on gear racks and guide rails, but no larger quantities should ooze out of the lifter or the guide block. The grease amount must be increased or reduced according to individual experience. This instruction also applies to the use of grease dispensers and central lubrication systems.

 When cleaning agents are used, care must be taken prior to recommissioning to ensure that the amount of lubricant meets the manufacturer's recommendations, and that no cleaning agent residue remains.

 **Note!** Do not use water-based lubricating coolants on gear racks. After no more than one year, we recommend that the lubrication cartridges be replaced, and that an initial lubrication be performed prior to installing the new lubrication cartridges. The maximum period of use of the lubrication cartridges is one year.

6 Replacement parts

Use only original LEANTECHNIK AG replacement parts for repairs on lifgo® & lean SL®. This is the only way to ensure that warranty claims against the manufacturer will be honored. Replacement and spare parts must meet the manufacturer's specifications. This also applies to the lubricants used.

When ordering replacement parts, the following information is required.

1. Article number and description of the required article: Article no.: e.g., "500 161 / L = ..."
Description: e.g., "Gear rack for lean SL® 5.0"
2. If spare parts lists and drawings are available:
 - Spare parts list and position number
 - Number of the drawing in which the replacement part is shown
3. Number of parts needed
4. Lead time

The ordering address for the manufacturer is found in Chapter 1.3.

7 Instructions for adjusting lifgo® eccentric 5.0 – 5.3

Also follow the functional & assembly videos under www.leantechnik.com. The following instructions apply to the lifgo® linear eccentric 5.0 – 5.3 lifter.

1. Remove the black, round retaining washers (2 pieces) on the sides of the pinion shaft, using a flat tool (flathead screwdriver or the like).

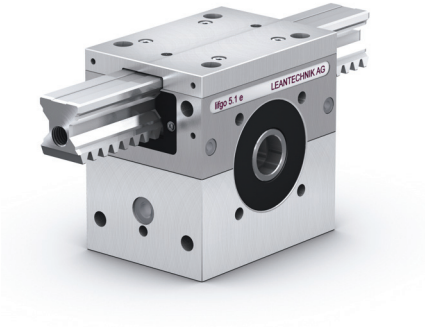

2. Loosen and remove all screws on the left and right of the eccentric disc.

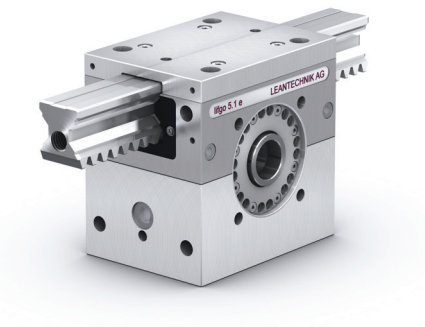

3. Use a marking pen to mark the position of the groove on the housing on the left and right of the eccentric disc.

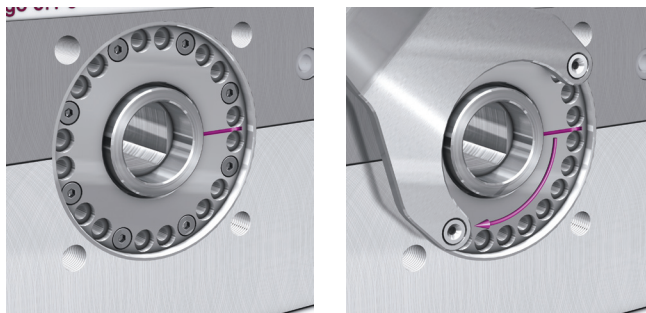

- Place the adjustment key on the eccentric disc (hole circle) and turn it in the desired direction **by one hole position**.

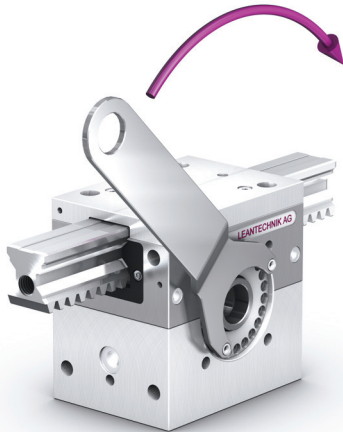

- Now use the adjustment key to turn the eccentric disc on the other side **by one hole position** in the same direction.



- Check the tooth clearance by holding the pinion (preventing it from rotating) and moving the gear rack back and forth in the guide direction (stop to stop). Measure the dimension with an indicator. If the result is as intended, then the procedure is complete.
- Insert all screws in the eccentric disc on the left and right, and tighten them to the specification. If the tooth flank clearance is to be reduced further, repeat steps 4 through 6.
- Install the retaining washers on the left and right.

- ! Take care that the groove markings on the left and right of the eccentric disc are congruent after the adjustment.
- ! Note that the groove marking may deviate by no more than one hole dimension during adjustment.